

# Installation Instructions

**Advantium® 240V  
Built-In SpeedCook  
Ovens**

PSB2200  
PSB2201  
ZSC2200  
ZSC2201  
ZSC2202

# Safety Information

## BEFORE YOU BEGIN

Read these instructions completely and carefully.

**IMPORTANT** – Save these instructions for local inspector’s use.

**IMPORTANT** – Observe all governing codes and ordinances.

- **Note to Installer** – Be sure to leave these instructions with the Consumer.
- **Note to Consumer** – Keep these instructions with your Owner’s Manual for future reference.
- **Skill Level** – Installation of this appliance requires basic mechanical and electrical skills.
- **Completion Time – 1 Hour.**
- Proper installation is the responsibility of the installer. Product failure due to improper installation is not covered under the warranty. See Owner’s Manual for warranty information.

**IMPORTANT** – Use this oven only for its intended purpose. Never use the oven for warming or heating a room. Prolonged use of the oven without proper ventilation can be hazardous.

### CAUTION:

For personal safety, remove house fuse or oven circuit breaker before beginning installation to avoid severe or fatal shock injury.

### CAUTION:

For personal safety, the mounting surface must be capable of supporting the cabinet load, in addition to the added weight of the 80-pound oven and 30-pound drawer, plus additional oven loads of up to 50 pounds or a total weight of up to 160 pounds.

### CAUTION:

For personal safety, this product cannot be installed in cabinet arrangements such as an island, a peninsula or below a countertop.

## CONTENTS

### Design Information

Models Available .....	2
Product Dimensions and Clearances .....	3
Tools and Parts Required .....	3
Parts Supplied .....	3
Electrical Tools and Parts Required .....	3
Advance Planning .....	3

### Installation Preparation

Electrical Requirements.....	4
Install Junction Box .....	4
Preparing the Opening (Installation without an accessory storage drawer).....	5-6
Preparing the Opening (Installation with an accessory storage drawer).....	7-8

### Installation Instructions

Step 1, Remove Packaging and Parts .....	9
Step 2, Route Conduit .....	10
Step 3, Install Bottom Trim .....	11
Step 4, Install Mounting Screws .....	11
Step 5, Finalize Installation .....	11

## MODELS AVAILABLE

### Profile Models:

PSB2200NWW–White  
PSB2200NBB–Black  
PSB2201NSS–Stainless Steel

### Monogram Models:

ZSC2200NWW–White  
ZSC2200NBB–Black  
ZSC2201NSS–Stainless Steel

### Monogram Pro Range Models:

ZSC2202NSS–Stainless Steel

**NOTE: This unit cannot be installed with an accessory storage drawer.**

# Design Information

## PRODUCT DIMENSIONS AND CLEARANCES

NOTE: Appearance will vary by model.

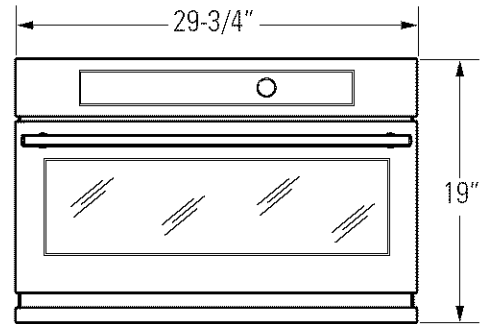
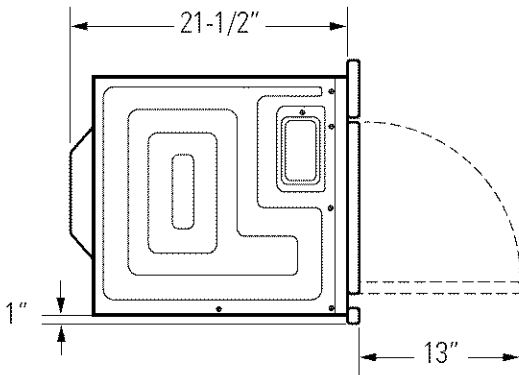

## TOOLS AND PARTS REQUIRED

### (NOT SUPPLIED)

- #2 Phillips screwdriver
- Hand held drill
- High speed drill bit, 3/32" diameter
- 3/8" slot head screwdriver
- Level
- Saw
- 2x4 or 2x2 lumber for installing runners or 3/8" plywood for floor (if required)
- Wood screws or other hardware for installing runner or shelf to support oven (if required)
- Safety glasses or goggles

## PARTS SUPPLIED

- 6 brass screws (3 required, 3 extra)
- 5 color matched screws (4 required, 1 extra)
- Bottom trim

## ELECTRICAL TOOLS AND PARTS REQUIRED (NOT SUPPLIED)

- Junction box
- Electrical cable (3-conductor or 4-conductor wire as required by local codes)
- UL-listed conduit connectors
- Wire cutters and wire strippers

## ADVANCE PLANNING

- These ovens may be installed directly into a 30" wide oven cabinet.
- Cutout dimensions are NOT the same for installation with or without an accessory storage drawer. Make sure to use the correct cutout when preparing the opening.

**NOTE:** Model ZSC2202 CANNOT be installed with an accessory storage drawer. See Installation Preparation Without an Accessory Storage Drawer for this model.

**IMPORTANT** – This oven is not approved for use above another built-in Advantium Speedcook oven, a side by side installation or below a countertop.

- For personal safety, this oven cannot be installed in a cabinet arrangement such as an island or peninsula.
- The oven must be installed at least 36-3/4" above the floor.
- Allow for clearance to adjacent corners, walls, drawers, etc.
- Cabinets installed adjacent to wall ovens must have an adhesion spec of at least 194°F temperature rating.

The oven must be securely installed in a cabinet that is firmly attached to the house structure.

Weight on the oven door could cause the oven to tip and result in injury. Never allow anyone to climb, sit, stand or hang on the oven door.

If installing the drawer accessory, the drawer must be assembled to the oven prior to installation into the cabinet. See the *Accessory Storage Drawer Assembly Instructions*.

# Installation Preparation

## ELECTRICAL REQUIREMENTS

### Single Speedcook Installation

Product rating is 120/208 or 120/240 volt, 60 Hz, 30 amps. This product must be connected to a supply circuit of the proper voltage and frequency and protected by a time delay fuse or circuit breaker. Power should be supplied from a separate, dedicated 30-ampere branch circuit. Wire size must conform to the requirements of the National Electrical Code or the prevailing local code.

### Combined Speedcook and Wall Oven Installation

When installed in combination with a GE/Monogram single wall oven, use separate electrical junction boxes.

Refer to single oven installation instructions for electrical requirements of that product.

These connections must be made by a qualified electrician. All electrical connections must meet National Electrical Code or prevailing local codes.

### Combined Speedcook and Warming Drawer Installation

When installing the Speedcook oven over a GE or Monogram electric warming drawer, a separate 120V, 60Hz, properly grounded receptacle must be installed. See instructions packed with the warming drawer.

## ⚠ WARNING

- The electrical power to the oven branch circuit must be shut off while line connections are being made.
- Use copper wiring only.
- Electrical ground is required on this appliance. The free end of the green wire (ground wire) must be connected to a suitable ground. This wire must remain grounded to the oven.
- If cold water pipe is interrupted by plastic, non-metallic gaskets, union connections or other insulating materials, DO NOT use for grounding.
- DO NOT ground to a gas pipe.
- DO NOT have a fuse in the NEUTRAL or GROUNDING circuit. A fuse in the NEUTRAL or GROUNDING circuit could result in an electrical shock.
- Check with a qualified electrician if you are in doubt as to whether the appliance is properly grounded.

Failure to follow these instructions could result in serious injury or death.

## INSTALL JUNCTION BOX

The conduit is located at the top right on the back of the oven.

Locate and install the junction box within reach of the oven conduit.

- Through the left or right sides of the cabinet wall and into adjacent cabinet.
- Or, through the cutout floor.
- Or, in the upper cabinet.

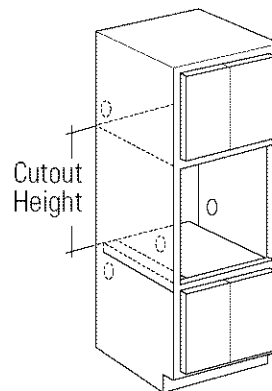

# Installation Preparation

## Preparation WITHOUT an Accessory Storage Drawer

### PREPARE THE OPENING

The Advantium 240V can be installed in combination with other GE/Monogram appliances. Always follow each product's Installation Instructions to complete the installation.

#### Single Advantium 240V Installation:

Order a 30" wide single oven cabinet or cut the opening in a wall to the dimensions shown.

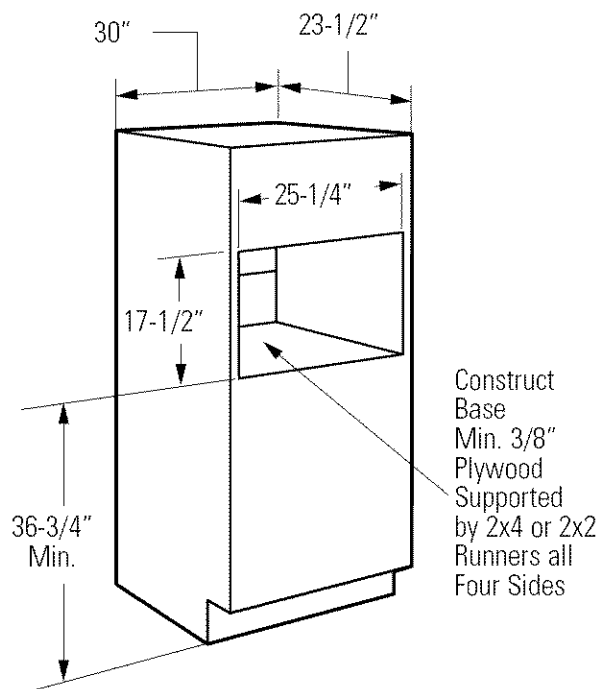

- Always maintain 36-3/4" minimum height from the floor to the cutout in any single or combined installation.
- Allow 2-1/8" case trim overlap on the sides and 7/8" overlap on the bottom of the opening for all models. Allow 1-1/4" case trim overlap on the top for models PSB2200 and PSB2201 and 3/4" overlap on the top for models ZSC2200, ZSC2201 and ZSC2202.
- Oven overlaps will conceal cut edges on all sides of the opening.

When installed over a single oven or a warming drawer, allow at least 2" between the two openings. This separation will provide clearance for bottom overlap of the Advantium 240V and the other appliance overlaps.

Construct a solid oven floor of 3/8" min. thick plywood supported by 2 x 4 or 2 x 2 runners on all sides.

- The support must be level and rigidly mounted, flush with the bottom edge of the cutout.

### PREPARE THE OPENING (CONT.)

#### Installation over a GE/Monogram Warming Drawer:

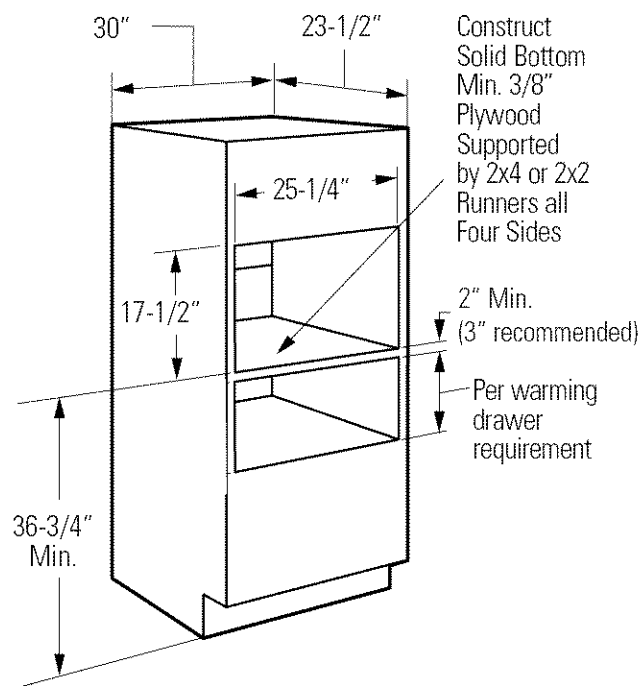

**NOTE:** Additional clearances between the cutouts may be required. Check to be sure the oven supports above the Warming Drawer location do not obstruct the required interior depth and height. See Warming Drawer installation instructions for details.

# Installation Preparation

## Preparation WITHOUT an Accessory Storage Drawer

### PREPARE THE OPENING (CONT.)

Installation over a GE/Monogram Oven:

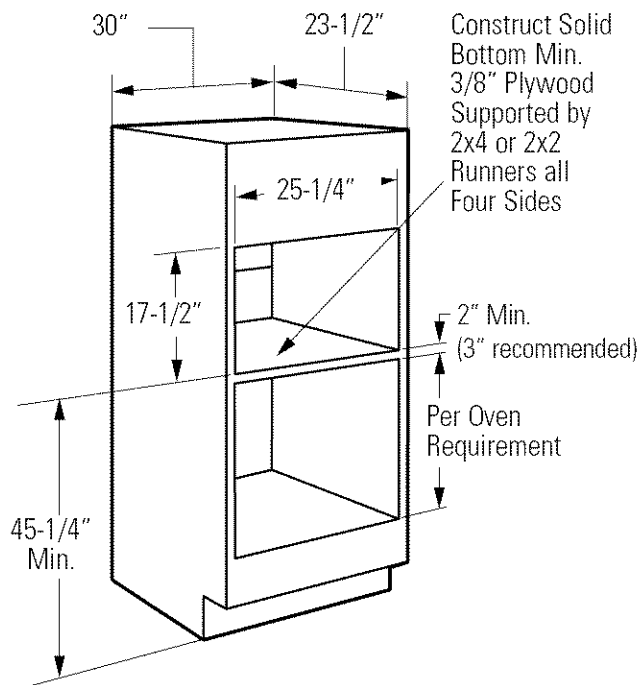

- If you are replacing a GE/Monogram electric double oven with the combined installation of an Advantium 240V and a single oven, use the dimensions shown. The middle rail separating the two openings may need to be larger than the 2" minimum shown.

### PREPARE THE OPENING (CONT.)

Installation over a GE/Monogram Oven and Warming Drawer:

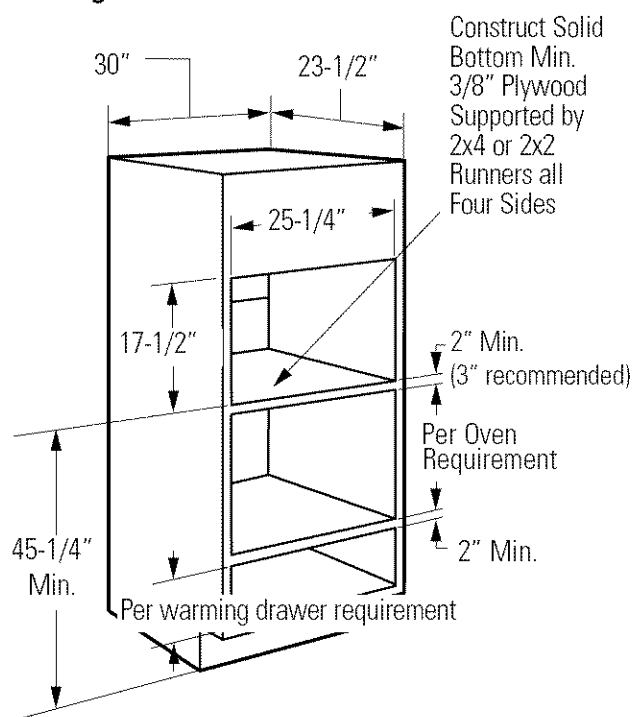

**NOTE:** Additional clearances between the cutouts may be required. Check to be sure the oven supports above the Warming Drawer location do not obstruct the required interior depth and height. See Warming Drawer installation instructions for details.

**CAUTION:** For personal safety, the mounting surface must be capable of supporting the cabinet load, in addition to the added weight of this approximate 80-pound oven, plus additional oven loads of up to 50 pounds or a total weight of 130 pounds.

# Installation Preparation

## Preparation WITH an Accessory Storage Drawer

NOTE: MODEL ZSC2202 CANNOT BE INSTALLED WITH AN ACCESSORY STORAGE DRAWER. SEE INSTALLATION PREPARATION WITHOUT AN ACCESSORY STORAGE DRAWER FOR THIS MODEL.

### PREPARE THE OPENING

The Advantium 240V can be installed in combination with other GE/Monogram appliances. Always follow each product's Installation Instructions to complete the installation.

#### Single Advantium 240V Installation:

Order a 30" wide single oven cabinet or cut the opening in a wall to the dimensions shown.

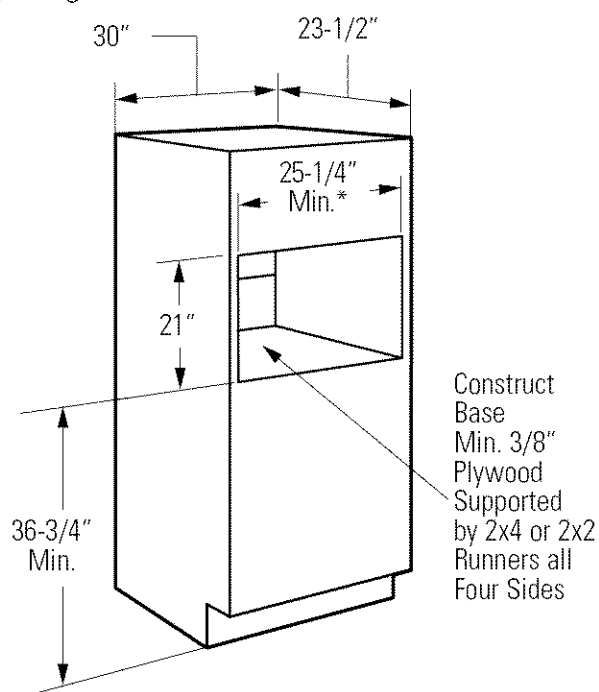

\* For existing cutouts, a maximum width of 28-1/2" is acceptable. If the opening is slightly wider, secure a furring strip on each side of the cutout for securing the oven.

- Always maintain 36-3/4" minimum height from the floor to the cutout in any single or combined installation.
- Allow 3/4" to 2-1/8" case trim overlap on the sides and 7/8" overlap on the bottom of the opening for all models. The amount of overlap on the sides depends on the actual cutout width. Allow 1-1/4" case trim overlap on the top for models PSB2200 and PSB2201 and 3/4" overlap on the top for models ZSC2200, ZSC2201 and ZSC2202.
- Oven overlaps will conceal cut edges on all sides of the opening.

### PREPARE THE OPENING (CONT.)

#### Single Advantium 240V Installation (cont.)

When installed over a single oven or a warming drawer, allow at least 2" between the two openings. This separation will provide clearance for bottom overlap of the Advantium 240V and the other appliance overlaps.

Construct a solid oven floor of 3/8" min. thick plywood supported by 2 x 4 or 2 x 2 runners on all sides.

- The support must be level and rigidly mounted, flush with the bottom edge of the cutout.

#### Installation over a GE/Monogram Warming Drawer:

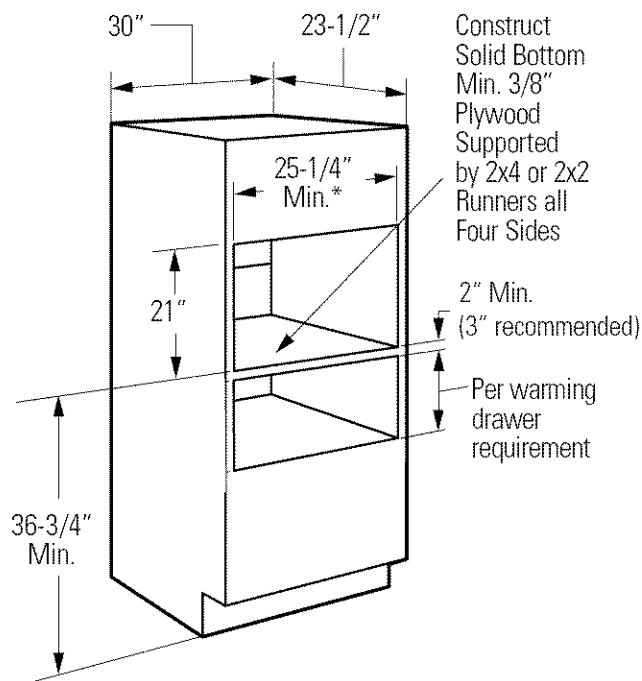

\* For existing cutouts, a maximum width of 28-1/2" is acceptable. If the opening is slightly wider, secure a furring strip on each side of the cutout for securing the oven.

**NOTE:** Additional clearances between the cutouts may be required. Check to be sure the oven supports above the Warming Drawer location do not obstruct the required interior depth and height. See Warming Drawer installation instructions for details.

# Installation Preparation

## Preparation WITH an Accessory Storage Drawer

NOTE: MODEL ZSC2202 CANNOT BE INSTALLED WITH AN ACCESSORY STORAGE DRAWER. SEE INSTALLATION PREPARATION WITHOUT AN ACCESSORY STORAGE DRAWER FOR THIS MODEL.

### PREPARE THE OPENING (CONT.)

Installation over a GE/Monogram Oven:

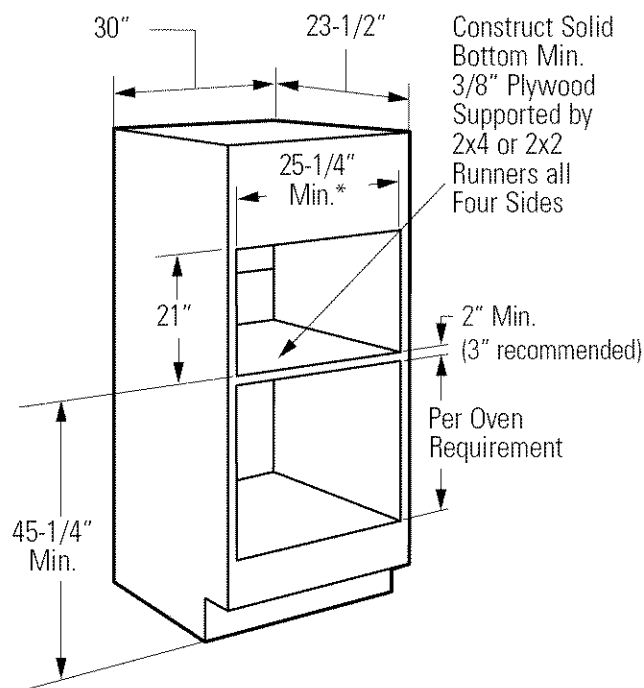

\* For existing cutouts, a maximum width of 28-1/2" is acceptable. If the opening is slightly wider, secure a furring strip on each side of the cutout for securing the oven.

- If you are replacing a GE/Monogram electric double oven with the combined installation of an Advantium 240V and a single oven, use the dimensions shown. The middle rail separating the two openings may need to be larger than the 2" minimum shown.

### PREPARE THE OPENING (CONT.)

Installation over a GE/Monogram Oven and Warming Drawer:

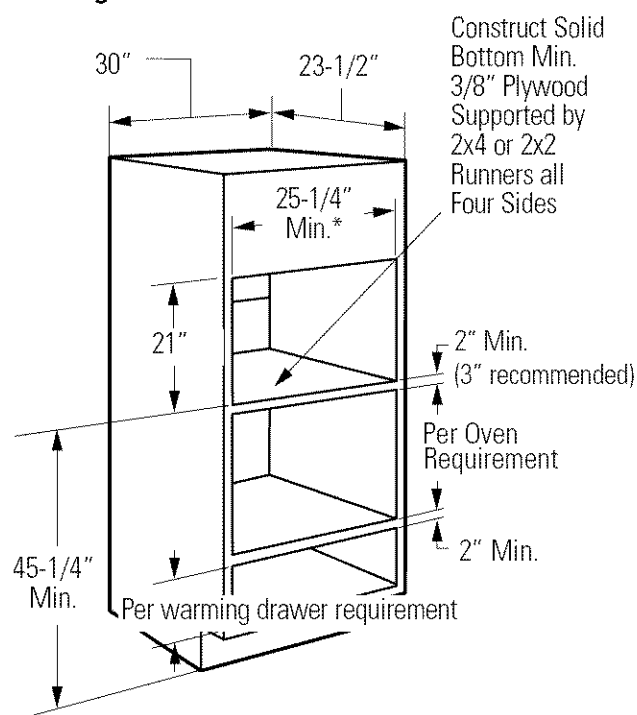

\* For existing cutouts, a maximum width of 28-1/2" is acceptable. If the opening is slightly wider, secure a furring strip on each side of the cutout for securing the oven.

**NOTE:** Additional clearances between the cutouts may be required. Check to be sure the oven supports above the Warming Drawer location do not obstruct the required interior depth and height. See Warming Drawer installation instructions for details.

**CAUTION:** For personal safety, the mounting surface must be capable of supporting the cabinet load, in addition to the added weight of this approximate 80-pound oven and 30-pound drawer, plus additional oven loads of up to 50 pounds or a total weight of 160 pounds.



# Installation Instructions

## 1 REMOVE THE PACKAGING AND PARTS

- Remove all packing material and tape.
- Locate parts package containing mounting screws.
- Remove the oven from the carton. Do not lift unit by handle or conduit. Two people are required to lift this oven.
- Open the door and remove any packaging in oven.

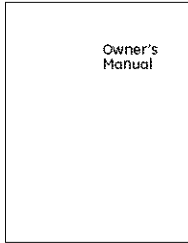

Owner's Manual

Owner's Manual

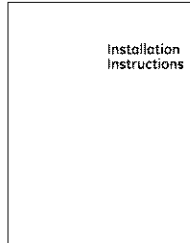

Installation Instructions

Installation Instructions

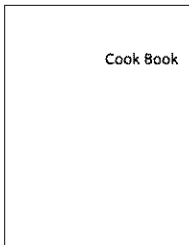

Cook Book

Cook Book

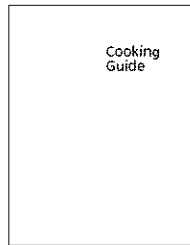

Cooking Guide

Cooking Guide

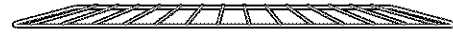

Rack

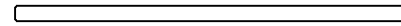

Bottom Trim

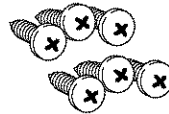

6 Brass Screws  
(3 required, 3 extra)

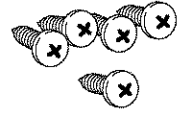

5 Color Matched Screws  
(4 required, 1 extra)



Glass Tray



Turntable Ring



Metal Trays (2)



Metal Grill Tray

**IMPORTANT:** If installing the Advantium 240V Oven with an accessory storage drawer, read the storage drawer assembly instructions to assemble the products together before proceeding to Step 2.

# Installation Instructions

## 2 ROUTE CONDUIT THROUGH CUTOUT

**CAUTION:** Two people are required to lift the oven into the opening. Grasp the bottom at front and rear. Discard foam base. DO NOT USE HANDLE OR CONDUIT TO LIFT THE OVEN. DAMAGE WILL OCCUR.

With oven in front of the cabinet opening:

- Insert conduit into cabinet opening. Connect oven wiring and branch circuit.
- Lift the oven into the opening while continuing to feed the conduit in the direction of the installed junction box. Be sure the conduit does not get pinched between the back of the oven and the cabinet wall.
- Leave oven a few inches forward of the cabinet front frame. Do not push the unit all of the way into the cutout.

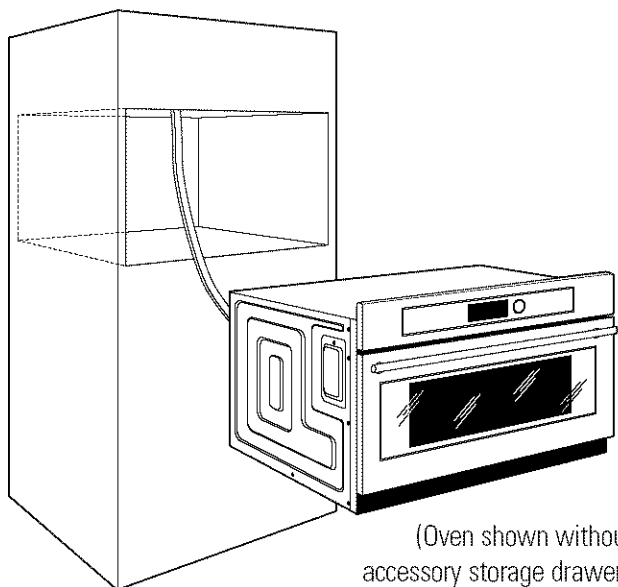

(Oven shown without accessory storage drawer.)

## ⚠ WARNING

- Disconnect power to the junction box before making the electrical connection.
- Electrical ground is required on this appliance.
- Do not connect the electrical supply until appliance is permanently grounded.

## GROUNDING INSTRUCTIONS

This appliance must be connected to a grounded, metallic, permanent wiring system, or an equipment grounding connector should be run with the circuit conductors and connected to the equipment grounding terminal or lead on the appliance. Failure to follow these instructions could result in fire, personal injury or electrical shock.

## 2 ROUTE CONDUIT THROUGH CUTOUT (CONT.)

When connecting to a 3-conductor branch circuit:

- Connect oven red lead to branch circuit red lead.
- Connect oven black lead to branch circuit black lead.
- Connect oven green ground lead and white lead to branch circuit neutral (white or gray).

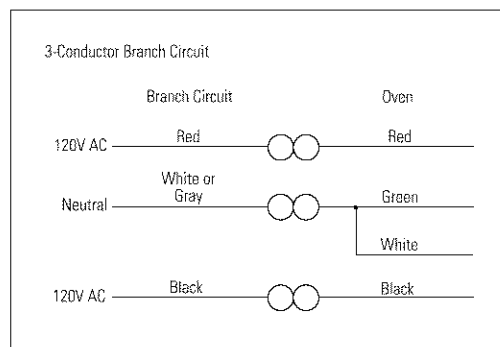

When connecting to a 4-conductor branch circuit:

- Connect oven red lead to branch circuit red lead.
- Connect oven black lead to branch circuit black lead.
- Break connection between oven white lead and oven green ground lead.
- Connect oven white lead to branch circuit neutral lead (white or gray).
- Connect oven green ground lead to branch circuit ground lead (green or bare copper).

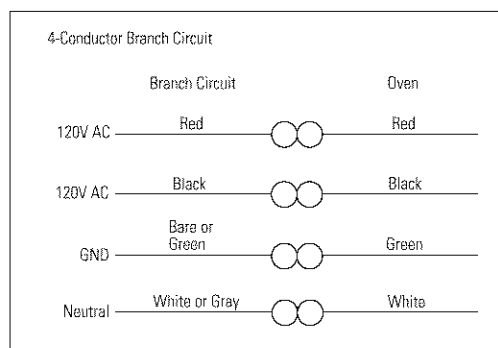

# Installation Instructions

## 3 INSTALL BOTTOM TRIM

**NOTE:** If installing the Advantium 240 Oven with an accessory storage drawer, the bottom trim is not required. Proceed to Step 4.

- Align bottom trim tabs to slots in the bottom of the oven.

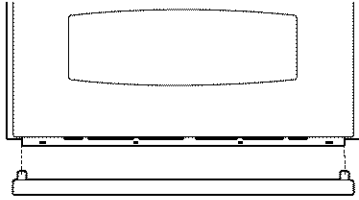

- Secure the bottom trim to the bottom of the oven using 3 brass screws provided.

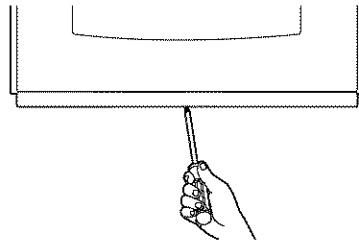

## 4 INSTALL MOUNTING SCREWS

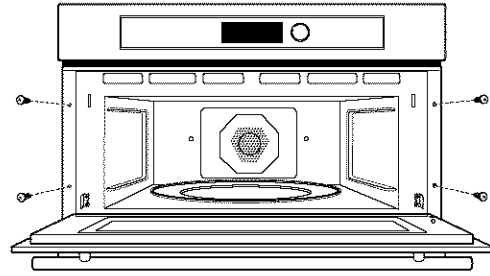

- Slide the oven the remaining way into the opening so that the side flanges and control panel are against the cabinet frame. Make sure that the oven is centered in the opening.
- Open the door, place a turntable tray in the oven and make sure that the tray in the unit is level.
- Drill pilot holes through the side flanges.
- Drive the color matched screws into the side flanges. It is recommended that the screws be hand tightened.

**If installing oven with an accessory storage drawer:**

- Open the drawer.
- Drill pilot holes through the side flanges.
- Drive color match screws into the side flanges. It is recommended that the screws be hand tightened.

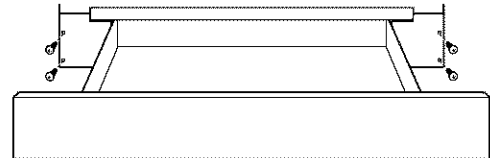

## 5 FINALIZE INSTALLATION

- Turn power on at the source. The interior light should come on when the door is opened.
- Refer to Owner's Manual for operating instructions.

# Assembly Instructions

## Advantium® 240V Built-In Accessory Storage Drawer JX2200, JX2201, ZX2201

### BEFORE YOU BEGIN

Read these instructions completely and carefully. Read the Installation Instructions for the Advantium 240V oven completely and carefully for cutout dimensions and step-by-step instructions.

**IMPORTANT** – Save these instructions for local inspector’s use.

**IMPORTANT** – Observe all governing codes and ordinances.

- **NOTE TO INSTALLER:** Be sure to leave these instructions with the Consumer.
- **NOTE TO CONSUMER:** Keep these instructions with your Advantium 240V Oven Owner’s Manual for future reference.
- **SKILL LEVEL:** Installation of this appliance requires basic mechanical skills.
- **COMPLETION TIME:** One hour with the installation of an Advantium 240V oven.
- Proper installation is the responsibility of the installer.
- Product failure due to improper installation is not covered under the Warranty. See the Advantium 240V Oven Owner’s Manual for warranty information.

### MODELS AVAILABLE

#### Profile Models:

JX2200BB–Black

JX2201SS–Stainless Steel

#### Monogram Models:

ZX2201SS–Stainless Steel

**NOTE: Advantium 240V Built-In SpeedCook Oven model ZSC2202SS CANNOT be installed with an accessory storage drawer.** See Installation Preparation Without an Accessory Storage Drawer in the Advantium 240V Built-In SpeedCook Oven Installation Instructions for this model.

### PRODUCT DIMENSIONS AND CLEARANCES

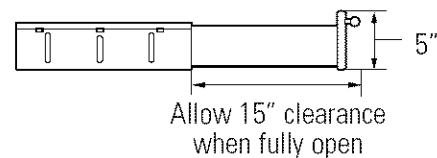

**NOTE:** Appearance will vary by model.

### TOOLS REQUIRED

- #2 Phillips screwdriver

### PARTS SUPPLIED

- 2 Side Supports
- Screws
- Screws (color matched)

# ASSEMBLY TO ADVANTIUM 240V BUILT-IN SPEEDCOOK OVEN

## 1 REMOVE PACKAGING AND PARTS

- Remove the drawer from the carton.
- Remove all packing material and tape.
- Open the drawer and remove any parts inside.
- Locate parts.

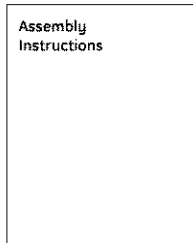

Assembly Instructions

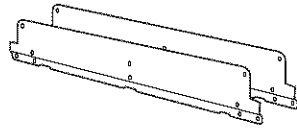

Side Supports (2)

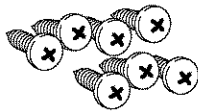

Screws (2 Sets)

## 2 ASSEMBLING THE OVEN TO DRAWER

- A** Place storage drawer on a surface with the front of drawer hanging over the edge of the surface. Not placing the front edge of drawer over the edge of the surface may result in damage to the drawer since the front edge of drawer hangs below the bottom of drawer.
- B** Place the oven on top of the storage drawer. Make sure that the back and sides of the oven align with the back and sides of drawer.

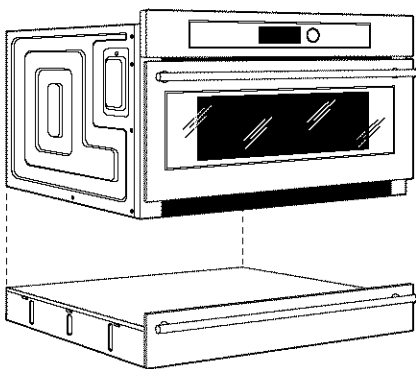

**NOTE:** The bottom of the oven side flanges will sit directly in front of the top of the storage drawer side flanges.

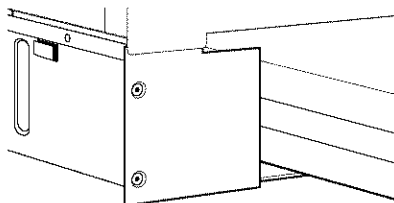

## ASSEMBLING THE OVEN TO DRAWER (CONT.)

- C** Remove the front two bottom screws on each side of the oven and the top center screw on each side of the storage drawer.

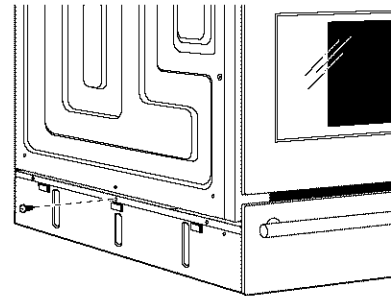
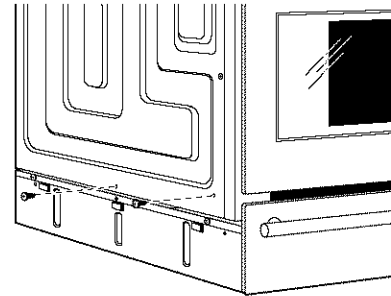

- D** Place the side supports into the tabs on the drawer and secure using the screws supplied and the screws removed in Step C.

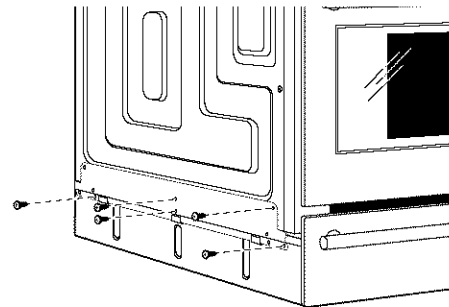

- E** The oven and storage drawer assembly is now ready to be installed. Return to the Advantium 240V Built-In SpeedCook Oven Installation Instructions to complete the installation.





**NOTE:** While performing installations described in this book, safety glasses or goggles should be worn.

**NOTE:** Product improvement is a continuing endeavor at General Electric. Therefore, materials, appearance and specifications are subject to change without notice.



**GE Consumer & Industrial**  
Appliances  
General Electric Company  
Louisville, KY 40225  
ge.com