

# WEIDER<sup>®</sup> PRO 220

Model No. 831.150290

Serial No. \_\_\_\_\_

Write the serial number in the space above for reference.

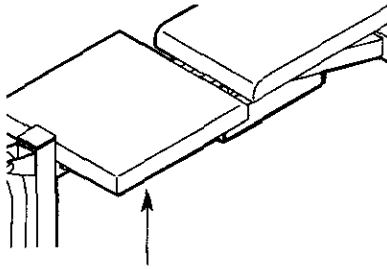

Serial Number Decal (under seat)

- Assembly
- Adjustments
- Troubleshooting
- Part List and Drawing

## ▲ CAUTION

Read all precautions and instructions in this manual before using this equipment. Save this manual for future reference.

## WEIGHT BENCH EXERCISER User's Manual

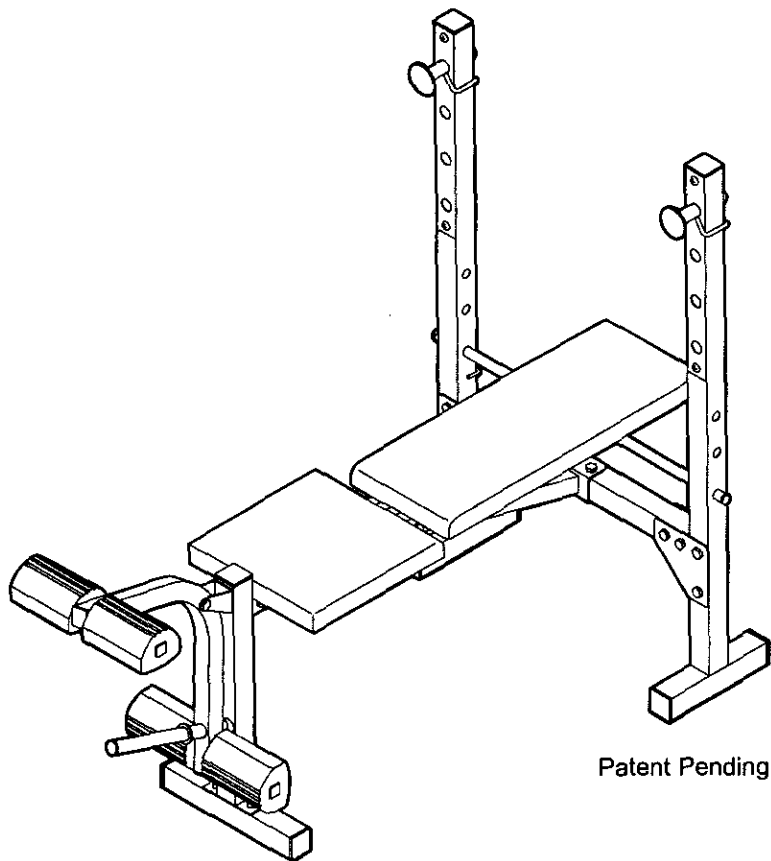

Patent Pending

Sears, Roebuck and Co., Hoffman Estates, IL 60179

# TABLE OF CONTENTS

WARNING DECAL PLACEMENT .....	2
IMPORTANT PRECAUTIONS .....	3
BEFORE YOU BEGIN .....	4
PART IDENTIFICATION CHART .....	5
ASSEMBLY .....	6
ADJUSTMENTS .....	10
EXERCISE GUIDELINES .....	11
PART LIST .....	14
EXPLODED DRAWING .....	15
ORDERING REPLACEMENT PARTS .....	Back Cover
WARRANTY .....	Back Cover

## WARNING DECAL PLACEMENT

The warning decals shown here have been placed on the weight bench in the locations shown. If a decal is missing or illegible, please call toll-free 1-800-999-3756, Mon. through Fri., 6 a.m. until 6 p.m. Mountain Time, to order a free replacement decal. Place the decal on the weight bench in the location shown.

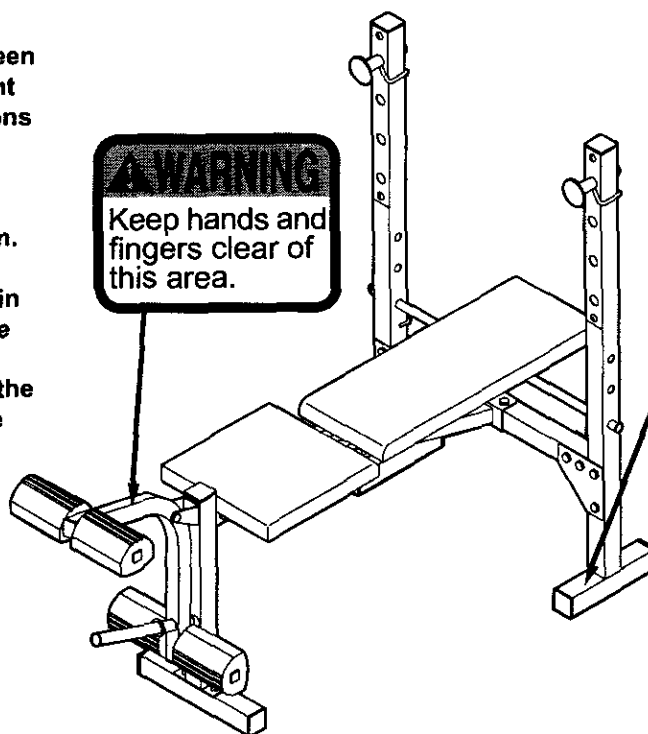

**WARNING**

- Misuse of this product may result in serious injury.
- Read user's manual and follow all warnings and operating instructions prior to use.
- Do not allow children on or around machine.
- Replace label if damaged, illegible, or removed.

# IMPORTANT PRECAUTIONS

**▲ WARNING:** To reduce the risk of serious injury, read the following important precautions before using the weight bench.

1. Read all instructions in this manual before using the weight bench. Use the weight bench only as described in this manual.
2. It is the responsibility of the owner to ensure that all users of the weight bench are adequately informed of all precautions.
3. The weight bench is intended for home use only. Do not use the weight bench in any commercial, rental, or institutional setting.
4. Use the weight bench only on a level surface. Cover the floor beneath the weight bench to protect the floor.
5. Make sure all parts are properly tightened each time the weight bench is used. Replace any worn parts immediately.
6. Keep children under 12 and pets away from the weight bench at all times.
7. Always wear athletic shoes for foot protection while exercising.
8. Keep hands and feet away from moving parts.
9. Do not use a barbell that is longer than six feet with the weight bench. Note: The weight bench does not include a barbell or weights.
10. The weight bench is designed to support a maximum user weight of 300 pounds, and a maximum total weight of 410 pounds. Do not place more than 110 pounds, including a barbell and weights, on the weight rests. Do not place more than 50 pounds on the leg lever.
11. Always be sure there is an equal amount of weight on each side of your barbell when you are using it. Always keep some weight on both ends of the barbell when adding or removing weights to prevent the barbell from tipping.
12. When you are using the leg lever, place a barbell with the same amount of weight on the weight rests to balance the bench.
13. Always exercise with a partner. When you are performing bench press exercises, your partner should stand behind you to catch the barbell if you cannot complete a repetition.
14. When using the backrest in an inclined position, make sure that the support rod is inserted completely through both uprights, and that the support rod is turned to the locked position.
15. If you feel pain or dizziness at any time while exercising, stop immediately and begin cooling down.

**▲ WARNING:** Before beginning this or any exercise program, consult your physician. This is especially important for persons over the age of 35 or persons with pre-existing health problems. Read all instructions before using. Sears assumes no responsibility for personal injury or property damage sustained by or through the use of this product.

## BEFORE YOU BEGIN

Thank you for selecting the versatile WEIDER® PRO 220 weight bench. The weight bench offers an impressive array of weight stations designed to develop every major muscle group of the body. Whether your goal is to tone your body, build dramatic muscle size and strength, or improve your cardiovascular system, the weight bench will help you to achieve the specific results you want.

**For your benefit, read this manual carefully before using the weight bench.** If you have questions after

reading this manual, call 1-800-4-MY-HOME® (1-800-469-4663). To help us assist you, please note the product model number and serial number before calling. The model number is 831.150290. The serial number can be found on a decal attached to the weight bench (see the front cover of this manual for the location of the decal).

Before reading further, please review the drawing below and familiarize yourself with the parts that are labeled.

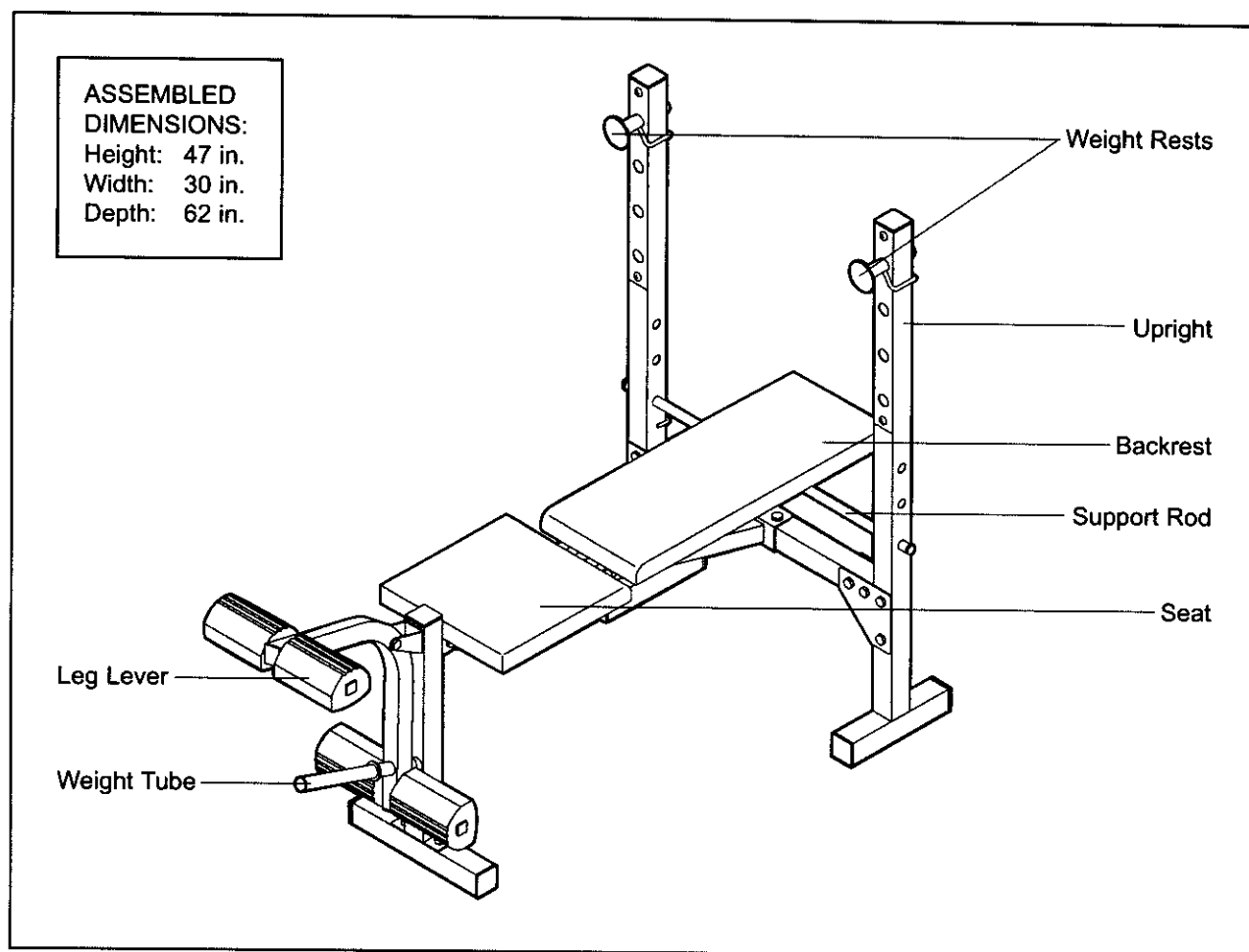

# PART IDENTIFICATION CHART

This chart is provided to help you identify the small parts used in assembly. The number in parenthesis below each part refers to the key number of the part, from the PART LIST on page 14 of this manual. **Important:** Some parts may have been pre-assembled for shipping purposes. If you cannot find a part in the parts bags, check to see if it has been pre-assembled. If a part is missing, call toll-free 1-800-999-3756.

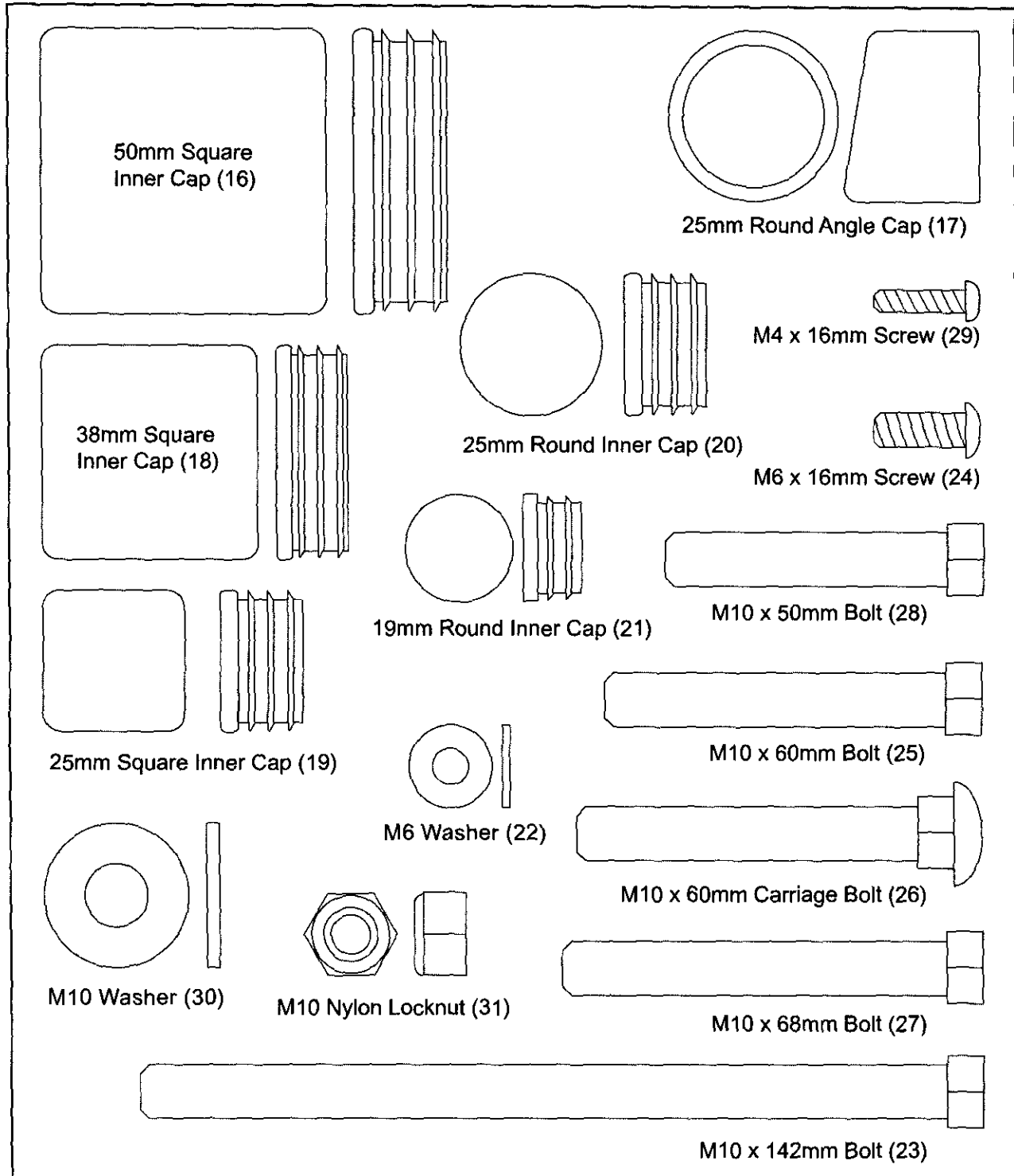

# ASSEMBLY

## Make Things Easier for Yourself





Everything in this manual is designed to ensure that the weight bench can be assembled successfully by anyone. However, it is important to realize that the versatile weight bench has many parts and that the assembly process will take time. Most people find that by setting aside plenty of time, assembly will go smoothly.

Before beginning assembly, carefully read the following information and instructions:

- Assembly requires two people.
- Place all parts in a cleared area and remove the packing materials. Do not dispose of the packing materials until assembly is completed.
- Tighten all parts as you assemble them, unless instructed to do otherwise.

- As you assemble the weight bench, make sure all parts are oriented as shown in the drawings.
- For help identifying small parts, use the **PART IDENTIFICATION CHART** on page 5.

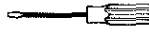
The following tools (not included) are required for assembly:

- Two adjustable wrenches 
- One rubber mallet 
- One standard screwdriver 
- One Phillips screwdriver 
- Lubricant, such as grease or petroleum jelly, and soapy water.

Assembly will be more convenient if you have a socket set, a set of open-end or closed-end wrenches, or a set of ratchet wrenches.

1. Before assembling the weight bench, be sure that you have read and understand the information in the box above.

Press three 50mm Square Inner Caps (16) into the Upright (1) without the warning decal.

Attach two Joint Plates (11) to the Upright (1) with two M10 x 68mm Bolts (27) and two M10 Nylon Locknuts (31). Do not tighten the Locknuts yet.

Repeat this step with the other Upright (1). Make sure the Joint Plates (11) are oriented as shown in the inset drawing.

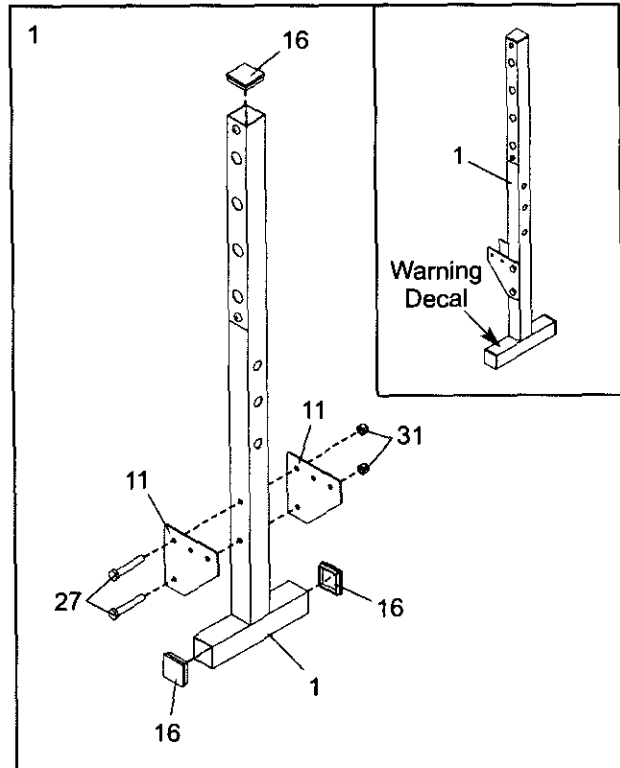

2. Attach the Crossbar (2) to an Upright (1) with two M10 x 68mm Bolts (27), two Joint Plates (11), and two M10 Nylon Locknuts (31). **Do not tighten the Locknuts yet.**

Repeat this step with the other Upright (1).

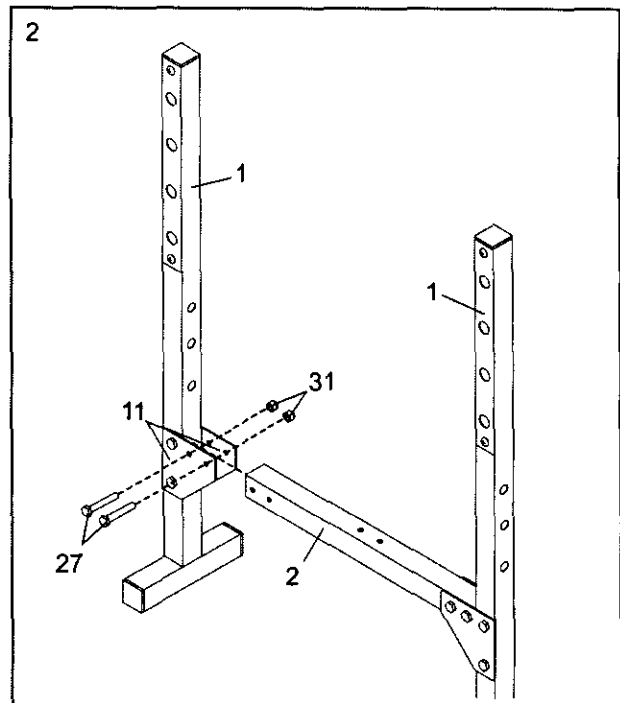

3. Press three 50mm Square Inner Caps (16) into the Front Leg (4) and the Stabilizer (5).

Attach the Front Leg (4) to the Stabilizer (5) with two M10 x 60mm Carriage Bolts (26) and two M10 Nylon Locknuts (31). **Do not tighten the Locknuts yet.**

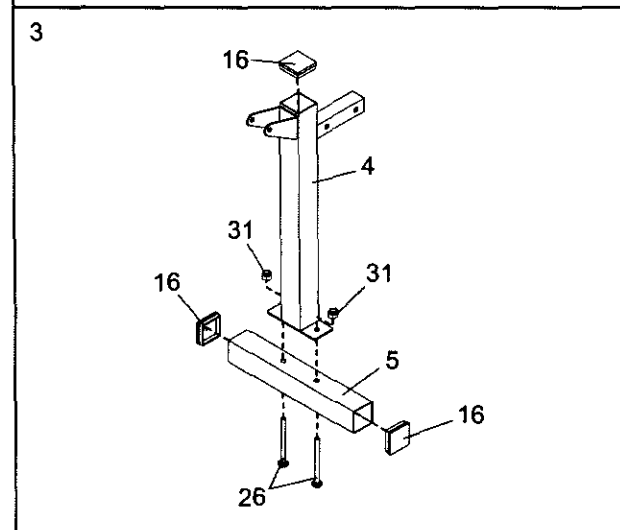

4. Attach the Front Leg (4) to the Bench Frame (3) with two M10 x 50mm Bolts (28), two M10 Washers (30), and two M10 Nylon Locknuts (31). **Do not tighten the Locknuts yet. Make sure the bolt heads fit inside the hexagon holes in the Bench Frame.**

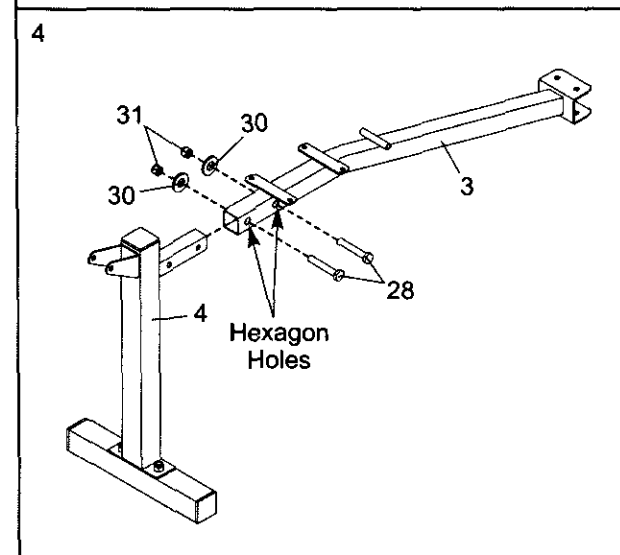

- Attach the Bench Frame (3) to the Crossbar (2) with two M10 x 68mm Bolts (27) and two M10 Nylon Locknuts (31).

**Tighten the M10 Nylon Locknuts (31) used in steps 1–5.**

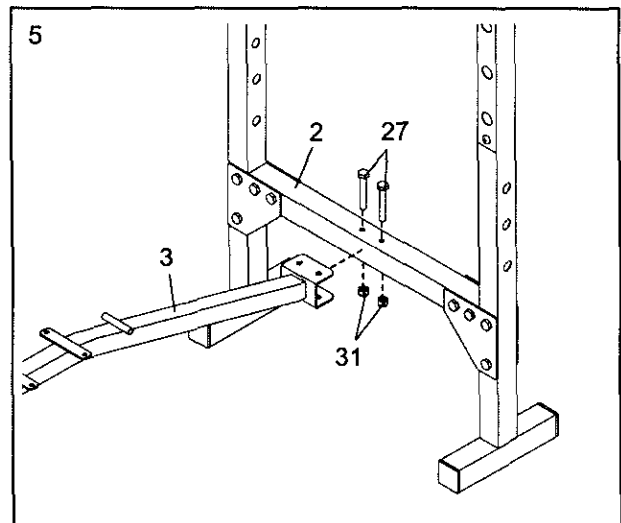

- Press a 25mm Round Inner Cap (20) into the indicated end of the weight tube on the Leg Lever (6). Press a 25mm Round Angled Cap (17) onto the other end of the weight tube.

Tap two 38mm Square Inner Caps (18) into the Leg Lever (6).

Lubricate the M10 x 60mm Bolt (25) with grease. Attach the Leg Lever (6) to the Front Leg (4) with the Bolt and an M10 Nylon Locknut (31). **Do not overtighten the Locknut; the Leg Lever must be able to pivot easily.**

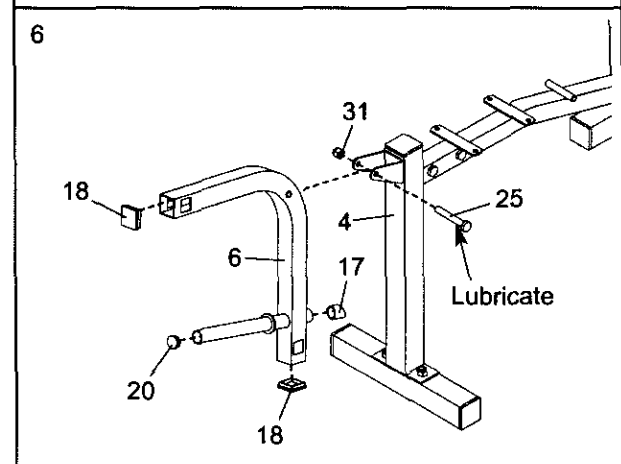

- Press two 25mm Square Inner Caps (19) into a Pad Tube (12). Slide the Pad Tube into the Leg Lever (6). Slide two Foam Pads (13) onto the ends of the Pad Tube. **Make sure the Foam Pads are oriented as shown.**

**Repeat this step with the other Pad Tube (12).**

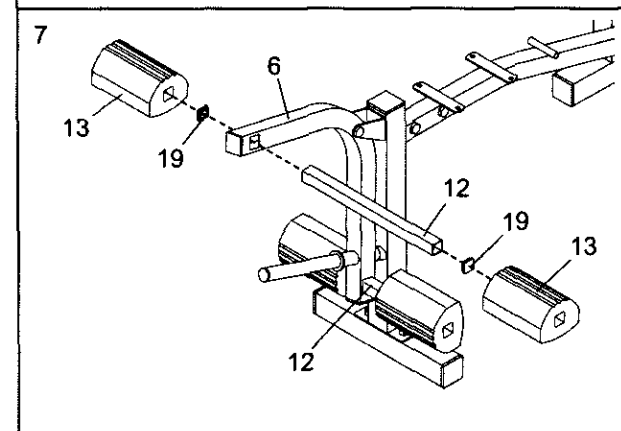

- Press a 25mm Round Inner Cap (20) into a Weight Rest (15). Insert the Weight Rest into an Upright (1). Turn the Weight Rest so the locking pin is wrapped around the Upright.

**Repeat this step with the other Weight Rest (15).**

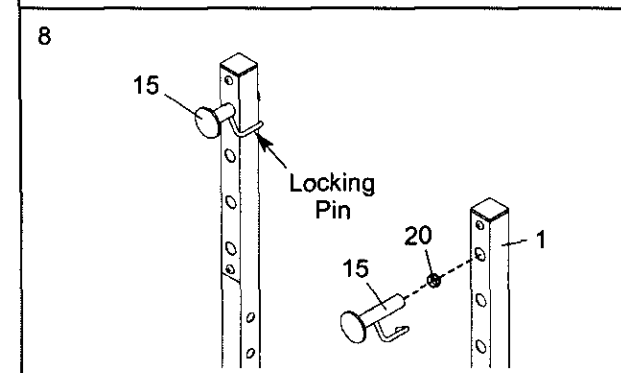



9. Press two 19mm Round Inner Cap (21) into the Support Rod (14). Insert the Support Rod into a set of holes in the Uprights (1). Turn the Support Rod so the locking pin is wrapped around the Upright.

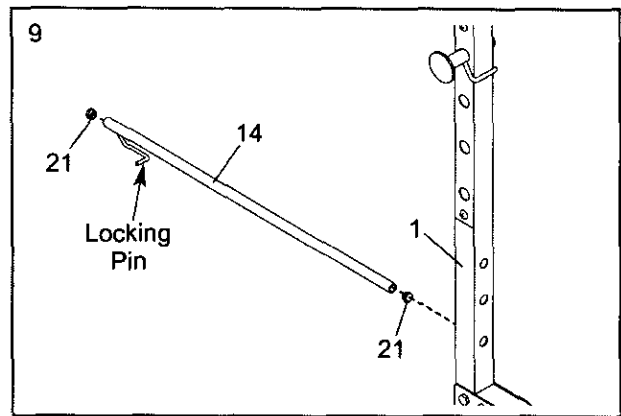

10. Press four 25mm Square Inner Caps (19) into the two Backrest Tubes (7).

Attach the Backrest Tubes (7) to the Backrest (8) with four M6 x 38mm Screws (32) and four M6 Washers (22). **Do not tighten the Screws yet.**

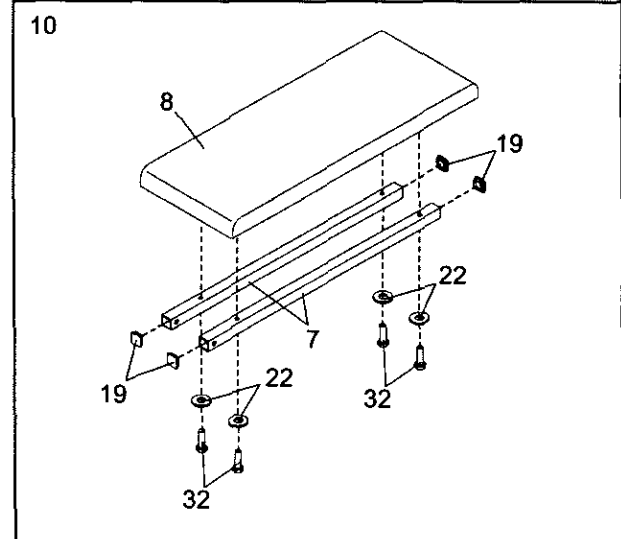

11. Lubricate an M10 x 142mm Bolt (23) with grease. Attach the Backrest Tubes (7) to the welded tube on the Bench Frame (3) with the Bolt, two M10 Washers (30), and an M10 Nylon Locknut (31). **Do not overtighten the Locknut; the Backrest Tubes must be able to pivot easily.**

**Tighten the M6 x 38mm Screws (32) used in step 10.**

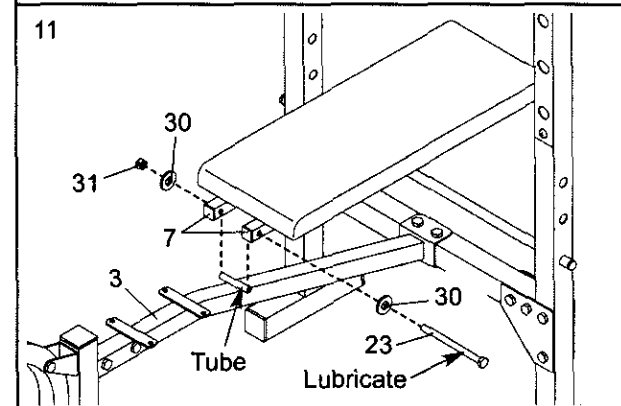

12. Attach the Seat (9) to the Bench Frame (3) with four M6 x 16mm Screws (24).

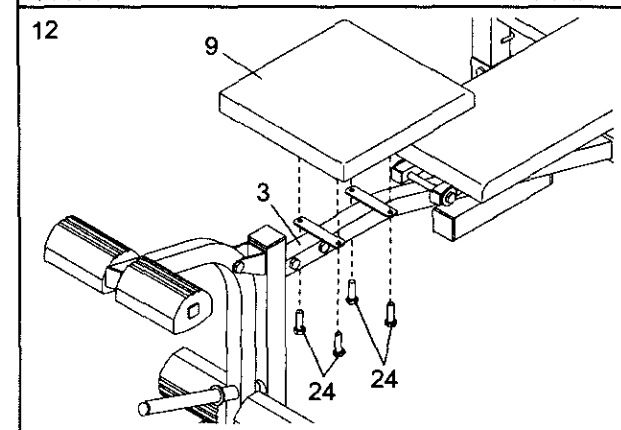

13. **Make sure that all parts are properly tightened before you use the weight bench.** The use of all remaining parts will be explained in ADJUSTMENTS, beginning on the following page.

# ADJUSTMENTS

The weight bench is designed to be used with your own weight set (not included). The steps below explain how the weight bench can be adjusted. See EXERCISE GUIDELINES on page 11 for important exercise information and refer to the accompanying exercise guide to see the correct form for each exercise. Refer also to the exercise information accompanying your weight set for additional exercises.

Make sure all parts are properly tightened each time the weight bench is used. Replace any worn parts immediately. The weight bench can be cleaned with a damp cloth and a mild, non-abrasive detergent. Do not use solvents.

## ADJUSTING THE BACKREST

The Backrest (8) can be used in a decline position, a level position, or two incline positions. To use the Backrest in the decline position, remove the Support Rod (14) and lay the Backrest on the Crossbar (2).

To use the Backrest (8) in the level position, lift the Backrest and insert the Support Rod (14) through the bottom set of holes in the Uprights (1). Rotate the locking pin into place around the Upright.

To use the Backrest (8) in an incline position, lift the Backrest and insert the Support Rod (14) through an upper set of holes in the Uprights (1). Rotate the locking pin into place around the Upright.

**▲WARNING:** When using the Backrest (8) in a level or incline position, insert the Support Rod (14) completely through both Uprights (1) and turn it to the locked position.

## ATTACHING WEIGHTS TO THE LEG LEVER

To use the Leg Lever (6), slide the desired weights (not included) onto the weight tube.

**▲WARNING:** Do not place more than 50 pounds on the Leg Lever (6).

## ADJUSTING THE WEIGHT RESTS

To change the weight of the Weight Rests (15), remove them from the Uprights (1) and insert them into the desired set of holes. Rotate the Weight Rests so that the locking pins wrap around the Uprights.

**▲WARNING:** Always set both Weight Rests (15) at the same height.

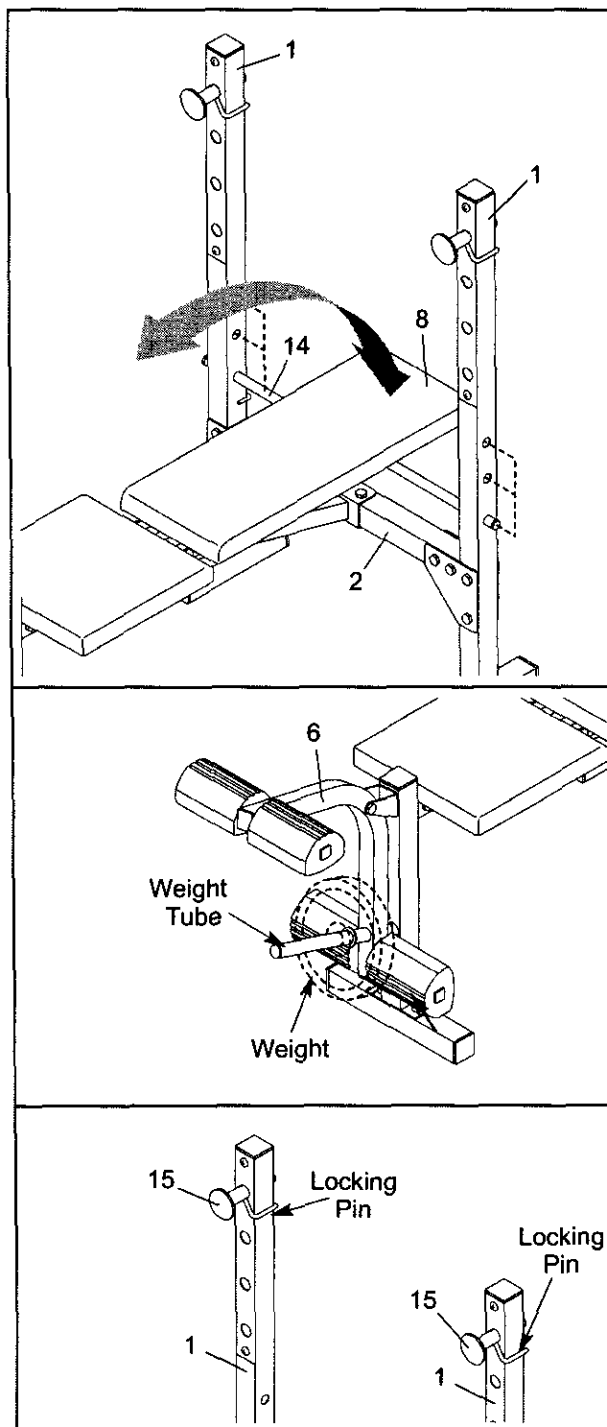

---

# EXERCISE GUIDELINES

## THE FOUR BASIC TYPES OF WORKOUTS

### Muscle Building

To increase the size and strength of your muscles, push them close to their maximum capacity. Your muscles will continually adapt and grow as you progressively increase the intensity of your exercise. You can adjust the intensity level of an individual exercise in two ways:

- by changing the amount of resistance used
- by changing the number of repetitions or sets performed. (A "repetition" is one complete cycle of an exercise, such as one sit-up. A "set" is a series of repetitions.)

The proper amount of resistance for each exercise depends upon the individual user. You must gauge your limits and select the amount of resistance that is right for you. Begin with 3 sets of 8 repetitions for each exercise you perform. Rest for 3 minutes after each set. When you can complete 3 sets of 12 repetitions without difficulty, increase the amount of resistance.

### Toning

You can tone your muscles by pushing them to a moderate percentage of their capacity. Select a moderate amount of resistance and increase the number of repetitions in each set. Complete as many sets of 15 to 20 repetitions as possible without discomfort. Rest for 1 minute after each set. Work your muscles by completing more sets rather than by using high amounts of resistance.

### Weight Loss

To lose weight, use a low amount of resistance and increase the number of repetitions in each set. Exercise for 20 to 30 minutes, resting for a maximum of 30 seconds between sets.

### Cross Training

Cross training is an efficient way to get a complete and well-balanced fitness program. An example of a balanced program is:

- Plan strength training workouts on Monday, Wednesday, and Friday.
- Plan 20 to 30 minutes of aerobic exercise, such as running on a treadmill or riding on an exercise bike, on Tuesday and Thursday.
- Rest from both strength training and aerobic exercise for at least one full day each week to give your body time to regenerate.

The combination of strength training and aerobic exercise will reshape and strengthen your body, plus develop your heart and lungs.

## PERSONALIZING YOUR EXERCISE PROGRAM

Determining the exact length of time for each workout, as well as the number of repetitions or sets completed, is an individual matter. It is important to avoid overdoing it during the first few months of your exercise program. You should progress at your own pace and be sensitive to your body's signals. If you experience pain or dizziness at any time while exercising, stop immediately and begin cooling down. Find out what is wrong before continuing. Remember that adequate rest and a proper diet are important factors in any exercise program.

### WARMING UP

Begin each workout with 5 to 10 minutes of stretching and light exercise to warm up. Warming up prepares your body for more strenuous exercise by increasing circulation, raising your body temperature and delivering more oxygen to your muscles.

### WORKING OUT

Each workout should include 6 to 10 different exercises. Select exercises for every major muscle group, emphasizing areas that you want to develop most. To give balance and variety to your workouts, vary the exercises from session to session.

Schedule your workouts for the time of day when your energy level is the highest. Each workout should be followed by at least one day of rest. Once you find the schedule that is right for you, stick with it.

### EXERCISE FORM

Maintaining proper form is an essential part of an effective exercise program. This requires moving through the full range of motion for each exercise, and moving only the appropriate parts of the body. Exercising in an uncontrolled manner will leave you feeling exhausted. On the exercise guide accompanying this manual you will find photographs showing the correct form for several exercises, and a list of the muscles affected. Refer to the muscle chart on the next page to find the names of the muscles.

The repetitions in each set should be performed smoothly and without pausing. The exertion stage of each repetition should last about half as long as the return stage. Proper breathing is important. Exhale during the exertion stage of each repetition and inhale during the return stroke. Never hold your breath.

Rest for a short period of time after each set. The ideal resting periods are:

- Rest for three minutes after each set for a muscle building workout.
- Rest for one minute after each set for a toning workout.
- Rest for 30 seconds after each set for a weight loss workout.

Plan to spend the first couple of weeks familiarizing yourself with the equipment and learning the proper form for each exercise.

### COOLING DOWN

End each workout with 5 to 10 minutes of stretching. Include stretches for both your arms and legs. Move

slowly as you stretch and do not bounce. Ease into each stretch gradually and go only as far as you can without strain. Stretching at the end of each workout is an effective way to increase flexibility.

### STAYING MOTIVATED

For motivation, keep a record of each workout. The chart on page 13 of this manual can be photocopied and used to schedule and record your workouts. List the date, the exercises performed, the resistance used, and the numbers of sets and repetitions completed. Record your weight and key body measurements at the end of every month. Remember, the key to achieving the greatest results is to make exercise a regular and enjoyable part of your everyday life.

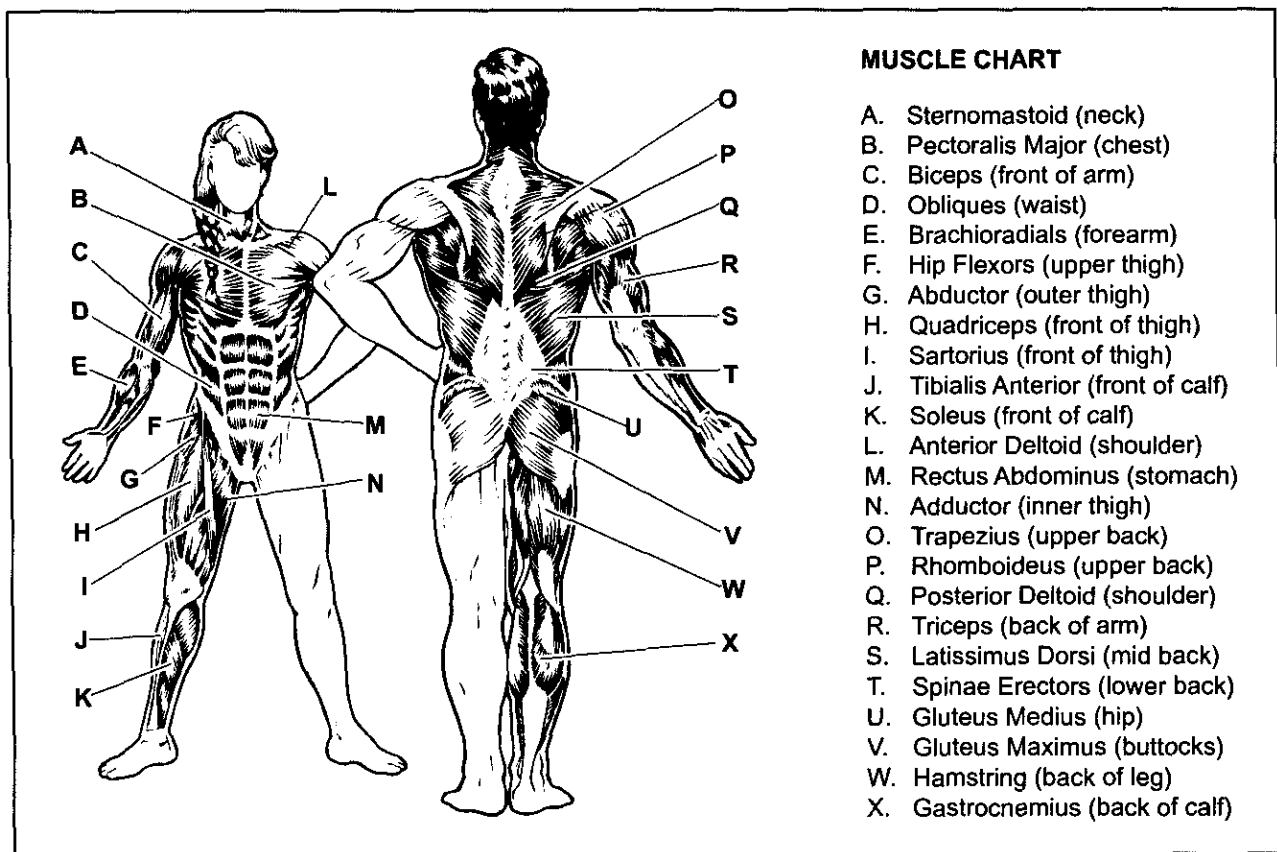

<b>MONDAY</b> Date: _ / _ / _	<b>EXERCISE</b>	<b>WEIGHT</b>	<b>SETS</b>	<b>REPS</b>

**TUESDAY AEROBIC EXERCISE**

Date:  
\_ / \_ / \_

<b>WEDNESDAY</b> Date: _ / _ / _	<b>EXERCISE</b>	<b>WEIGHT</b>	<b>SETS</b>	<b>REPS</b>

**THURSDAY AEROBIC EXERCISE**

Date:  
\_ / \_ / \_

<b>FRIDAY</b> Date: _ / _ / _	<b>EXERCISE</b>	<b>WEIGHT</b>	<b>SETS</b>	<b>REPS</b>

Make photocopies of this page for scheduling and recording your workouts.

# PART LIST—Model No. 831.150290

R0803A

Key No.	Qty.	Description	Key No.	Qty.	Description
1	2	Upright	19	8	25mm Square Inner Cap
2	1	Crossbar	20	3	25mm Round Inner Cap
3	1	Bench Frame	21	2	19mm Round Inner Cap
4	1	Front Leg	22	4	M6 Washer
5	1	Stabilizer	23	1	M10 x 142mm Bolt
6	1	Leg Lever	24	4	M6 x 16mm Screw
7	2	Backrest Tube	25	1	M10 x 60mm Bolt
8	1	Backrest	26	2	M10 x 60mm Carriage Bolt
9	1	Seat	27	10	M10 x 68mm Bolt
10	2	Upright Cover	28	2	M10 x 50mm Bolt
11	4	Joint Plate	29	4	M4 x 16mm Screw
12	2	Pad Tube	30	4	M10 Washer
13	4	Foam Pad	31	16	M10 Nylon Locknut
14	1	Support Rod	32	4	M6 x 38mm Screw
15	2	Weight Rest	#	1	User's Manual
16	9	50mm Square Inner Cap	#	1	Exercise Guide
17	1	25mm Round Angled Cap	#	1	Grease Pack
18	2	38mm Square Inner Cap			

"#" Indicates a non-illustrated part. Specifications are subject to change without notice. See the back cover of this manual for information on ordering replacement parts.

# EXPLODED DRAWING—Model No. 831.150290

R0803A

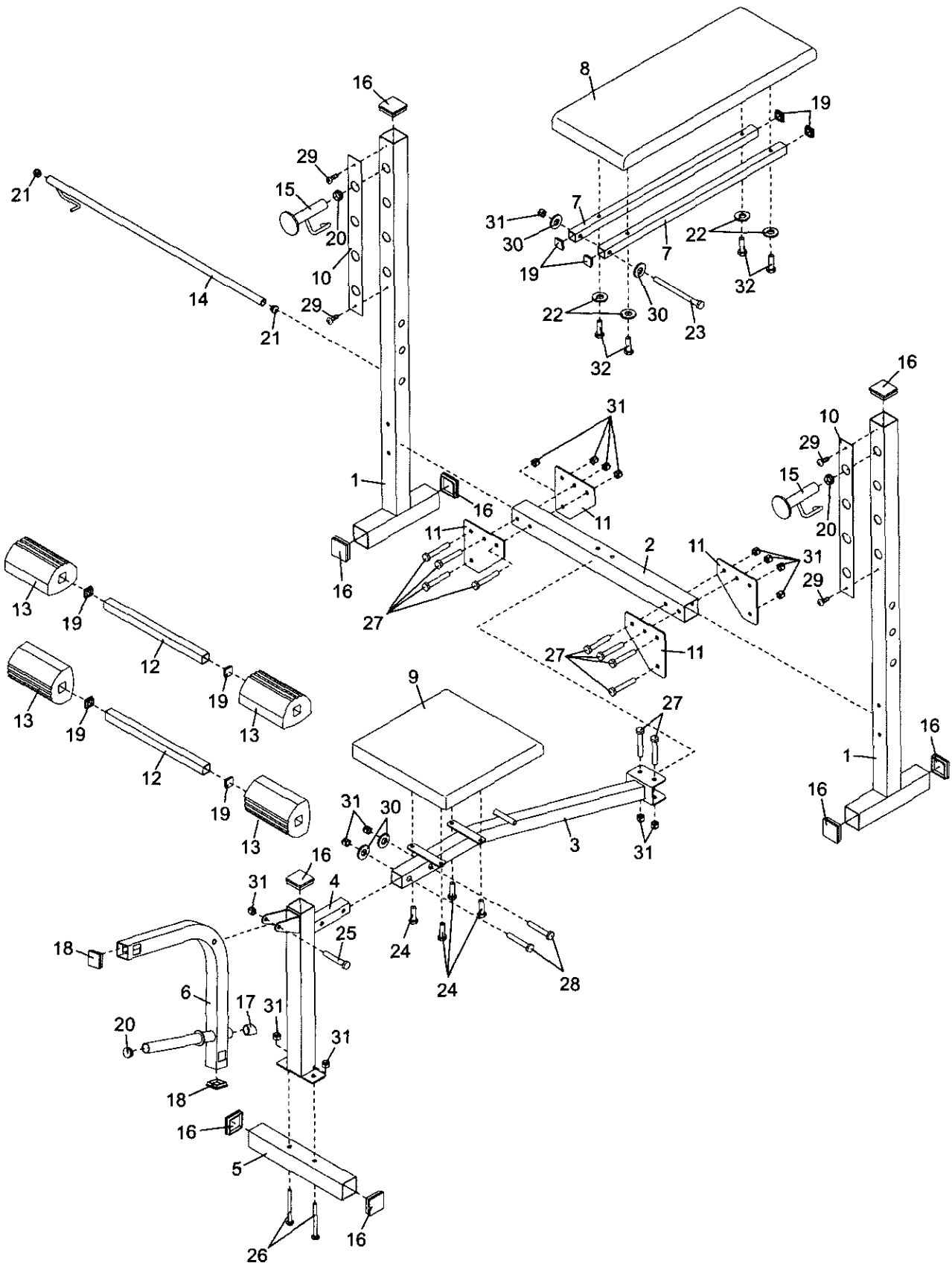

## Get it fixed, at your home or ours!

### Your Home

For repair – **in your home** – of **all** major brand appliances, lawn and garden equipment, or heating and cooling systems, **no matter who made it, no matter who sold it!**

For the replacement parts, accessories, and user's manuals that you need to do-it-yourself.

For Sears professional installation of home appliances and items like garage door openers and water heaters.

**1-800-4-MY-HOME®**

(1-800-469-4663)

[www.sears.com](http://www.sears.com)

Anytime, day or night

(U.S.A. and Canada)

[www.sears.ca](http://www.sears.ca)

### Our Home

For repair of carry-in products like vacuums, lawn equipment, and electronics, call or go on-line for the location of your nearest **Sears Parts and Repair Center.**

**1-800-488-1222** Anytime, day or night (U.S.A. only)

[www.sears.com](http://www.sears.com)

To purchase a protection agreement (U.S.A.) or maintenance agreement (Canada) on a product serviced by Sears:

**1-800-827-6655** (U.S.A.)

**1-800-361-6665** (Canada)

Para pedir servicio de reparación a domicilio, y para ordenar piezas:

**1-888-SU-HOGAR<sup>SM</sup>** (1-888-784-6427)

# SEARS

® Registered Trademark / ™ Trademark / <sup>SM</sup> Service Mark of Sears, Roebuck and Co.  
® Marca Registrada / ™ Marca de Fábrica / <sup>SM</sup> Marca de Servicio de Sears, Roebuck and Co.

## WARRANTY

For 90 days from the date of purchase, if failure occurs due to defect in material or workmanship in this WEIGHT BENCH EXERCISER, contact the nearest Sears Service Center throughout the United States and Sears will repair or replace the WEIGHT BENCH EXERCISER, free of charge.

This warranty does not apply when the WEIGHT BENCH EXERCISER is used commercially or for rental purposes.

This warranty gives you specific legal rights, and you may also have other rights which vary from state to state.

**Sears, Roebuck and Co., Dept. 817WA, Hoffman Estates, IL 60179**