



48JZ(N) 024-060

Single Packaged Gas Heating/Electric Heat Pump Units With Puron® (R-410A) Refrigerant

Visit www.carrier.com

Installation, Start-Up, and Operating Instructions

NOTE: Read the entire instruction manual before starting the installation.

TABLE OF CONTENTS

| | |
|---|----|
| SAFETY CONSIDERATIONS | 1 |
| INTRODUCTION | 2 |
| RECEIVING AND INSTALLATION | 2 |
| CHECK EQUIPMENT | 2 |
| IDENTIFY UNIT | 2 |
| INSPECT SHIPMENT | 2 |
| PROVIDE UNIT SUPPORT | 2 |
| ROOF CURB | 2 |
| SLAB MOUNT | 2 |
| GROUND MOUNT | 2 |
| FIELD FABRICATE DUCTWORK | 3 |
| PROVIDE CLEARANCES | 4 |
| RIG AND PLACE UNIT | 6 |
| CONNECT CONDENSATE DRAIN | 6 |
| INSTALL FLUE HOOD | 6 |
| INSTALL GAS PIPING | 7 |
| INSTALL DUCT CONNECTIONS | 9 |
| CONFIGURING UNITS FOR DOWNFLOW (VERTICAL) DISCHARGE | 9 |
| INSTALL ELECTRICAL CONNECTIONS | 10 |
| HIGH-VOLTAGE CONNECTIONS | 10 |
| SPECIAL PROCEDURES FOR 208-V OPERATION | 11 |
| CONTROL VOLTAGE CONNECTIONS | 11 |
| HEAT ANTICIPATOR SETTING | 11 |
| TRANSFORMER PROTECTION | 11 |
| PRE-START-UP | 12 |
| START-UP | 13 |
| CHECK FOR REFRIGERANT LEAKS | 13 |
| START-UP HEAT AND MAKE ADJUSTMENTS | 13 |
| CHECK HEATING CONTROL | 13 |
| HEATING SEQUENCE OF OPERATION-HEAT PUMP | 18 |
| HEATING SEQUENCE OF OPERATION-GAS HEAT | 18 |
| START-UP COOLING AND MAKE ADJUSTMENTS | 19 |
| COOLING SEQUENCE OF OPERATION | 19 |
| CHECKING COOLING CONTROL OPERATION (NON-ICM UNITS) | 19 |
| MAINTENANCE | 20 |
| AIR FILTER | 22 |
| INDOOR BLOWER AND MOTOR | 22 |
| FLUE GAS PASSAGEWAYS | 24 |
| COMBUSTION-AIR BLOWER | 24 |
| LIMIT SWITCH | 25 |
| BURNER IGNITION | 25 |
| MAIN BURNERS | 25 |
| OUTDOOR COIL, INDOOR COIL, AND CONDENSATE DRAIN | 25 |
| OUTDOOR FAN | 25 |

| | |
|--------------------------------------|----|
| ELECTRICAL CONTROLS AND WIRING | 25 |
| HEAT PUMP SYSTEM ITEMS | 26 |
| REFRIGERANT CIRCUIT | 27 |
| GAS INPUT | 27 |
| INDOOR AIRFLOW | 27 |
| PURON® SYSTEM ITEMS | 27 |

| | |
|--------------------------|----|
| TROUBLESHOOTING | 28 |
| START-UP CHECKLIST | 28 |

NOTE TO INSTALLER — Before the installation, READ THESE INSTRUCTIONS CAREFULLY AND COMPLETELY. Also, make sure the User's Manual and Replacement Guide are left with the unit after installation. The furnace is NOT to be used for temporary heating of buildings or structures under construction.

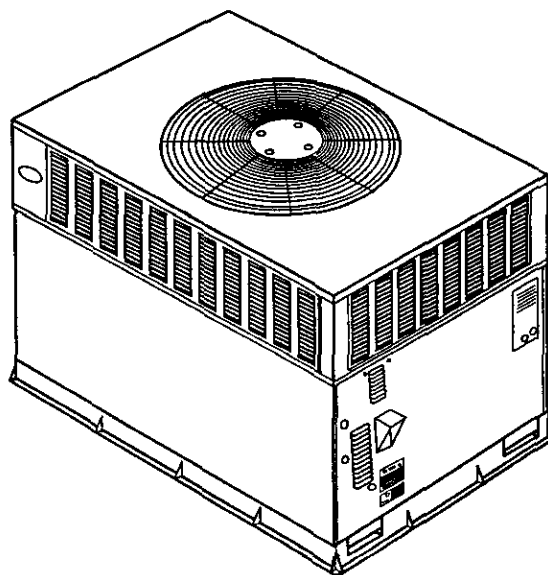

C99088

Fig. 1—Unit 48JZ

SAFETY CONSIDERATIONS

Installation and servicing of air-conditioning equipment can be hazardous due to system pressure and electrical components. Only trained and qualified personnel should install, repair, or service air-conditioning equipment.

Untrained personnel can perform basic maintenance functions of cleaning coils and filters. All other operations should be performed by trained service personnel. When working on air-conditioning equipment, observe precautions in the literature, tags, and labels attached to the unit, and other safety precautions that may apply.

Follow all safety codes. Wear safety glasses and work gloves. Use quenching cloth for unbrazing operations. Have fire extinguisher available for all brazing operations.

Manufacturer reserves the right to discontinue, or change at any time, specifications or designs without notice and without incurring obligations.

▲ WARNING

Improper installation, adjustment, alteration, service, maintenance, or use can cause carbon monoxide poisoning, fire, or an explosion which can result in serious injury, death or unit damage. Consult a qualified installer, service agency, or gas supplier for information or assistance. The qualified installer or agency must use only factory-authorized kits or accessories when modifying this product.

▲ WARNING

Before performing service or maintenance operations on unit, turn off gas supply to unit. Then turn off unit main power switch and install lock-out tag. Electrical shock or explosion could cause serious injury or death.

Recognize safety information. This is the safety-alert symbol ▲. When you see this symbol in instructions or manuals, be alert to the potential for personal injury.

Understand the signal words DANGER, WARNING, CAUTION, and NOTE. These words are used with the safety-alert symbol. DANGER identifies the most serious hazards which will result in severe personal injury or death. WARNING signifies a hazard which could result in personal injury or death. CAUTION is used to identify unsafe practices which would result in minor personal injury or product and property damage. NOTE is used to highlight suggestions which will result in enhanced installation, reliability, or operation.

These instructions cover minimum requirements and conform to existing national standards and safety codes. In some instances, these instructions exceed certain local codes and ordinances, especially those that may not have kept up with changing residential construction practices. We require these instructions as a minimum for a safe installation.

INTRODUCTION

The 48JZ unit (See Fig. 1) is a fully self-contained, combination electric heat pump unit with gas-fired back-up heat designed for outdoor installation (See Fig. 2 and 3 for unit dimensions). All unit sizes have return and discharge openings for both horizontal and downflow configurations, and are factory shipped with all downflow duct openings covered. Units may be installed either on a rooftop, a cement slab, or directly on the ground if local codes permit (See Fig. 4 for roof curb dimensions).

Models with an N in the fifth position (available on single phase only) of the model number are dedicated Low NOx units designed for California installations.

NOTE: Low NOx requirements apply only to natural gas installations.

These models meet the California maximum oxides of nitrogen (NOx) emissions requirements of 40 nanograms/joule or less as shipped from the factory and must be installed in California Air Quality Management Districts where a Low NOx rule exists.

NOTE: In order for this unit to run as designed, you must install with either Carrier's Thermidstat™ control or Dual fuel thermostat. We recommend the Thermidstat™ control if using variable speed blower motors.

RECEIVING AND INSTALLATION

Step 1—CHECK EQUIPMENT

IDENTIFY UNIT

The unit model number and serial number are stamped on unit identification / rating plate. Check this information against shipping papers and job data.

Ensure electrical power supply provided for unit matches the requirements listed on the unit rating plate.

INSPECT SHIPMENT

Inspect for shipping damage while unit is still on shipping pallet. If unit appears to be damaged or is torn loose from its anchorage, have it examined by transportation inspectors before removal. Forward claim papers directly to transportation company. Manufacturer is not responsible for any damage incurred in transit.

Check all items against shipping list. Immediately notify the nearest distributor if any item is missing.

To prevent loss or damage, leave all parts in original packages until installation.

Step 2—PROVIDE UNIT SUPPORT

ROOF CURB

Install accessory roof curb in accordance with instructions shipped with curb (See Fig. 4 for roof curb dimensions). Install insulation, cant strips, roofing, and flashing. Ductwork must be attached to curb.

IMPORTANT: The gasketing of the unit to the roof curb is critical for a watertight seal. Install gasketing material supplied with the roof curb. Improperly applied gasketing can also result in air leaks and poor unit performance.

Curb should be level to within 1/4 in. This is necessary for unit drain to function properly. Refer to accessory roof curb installation instructions for additional information as required.

SLAB MOUNT

Place the unit on a solid, level concrete pad that is a minimum of 4 in. thick with 2 in. above grade. The slab should be flush on the compressor end of the unit (to allow condensate drain installation) and should extend 2 in. on the three remaining sides of the unit. Do not secure the unit to the slab *except* when required by local codes.

GROUND MOUNT

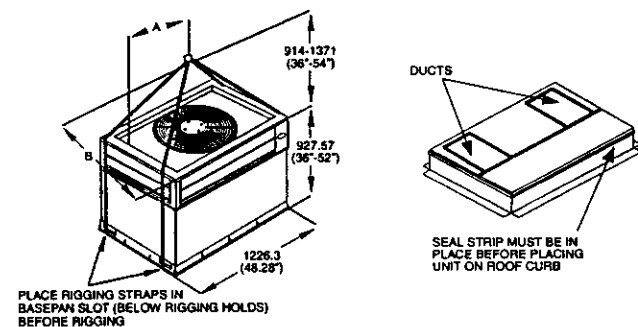

| UNIT | MAXIMUM WEIGHT | | A | | B | |
|-----------|----------------|-----|------|-------|-------|-------|
| | lb | kg | in. | mm | in. | mm |
| UNIT 48JZ | | | | | | |
| 024 | 332 | 151 | 22.0 | 558.5 | 14.50 | 368.3 |
| 030 | 346 | 157 | 22.0 | 558.5 | 15.30 | 388.6 |
| 036 | 343 | 156 | 22.0 | 558.5 | 15.30 | 388.6 |
| 042 | 402 | 182 | 23.0 | 584.2 | 16.3 | 414.0 |
| 048 | 431 | 195 | 21.5 | 546.1 | 16.3 | 414.0 |
| 060 | 526 | 239 | 23.5 | 596.9 | 16.3 | 414.3 |

Fig. 6—Suggested Rigging

The unit may be installed either on a slab or placed directly on the ground if local codes permit. Place the unit on level ground prepared with gravel for condensate discharge.

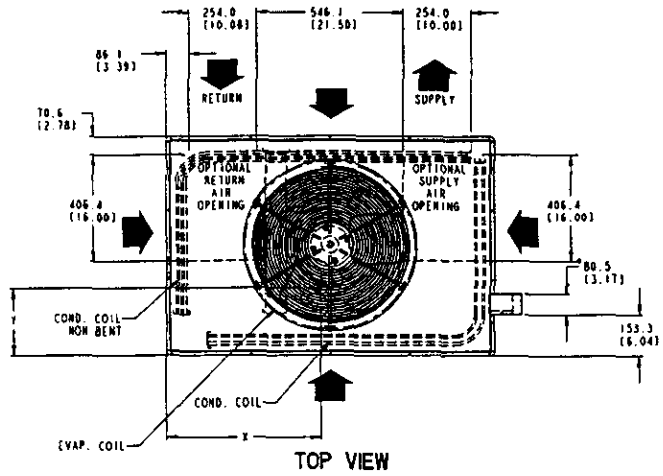
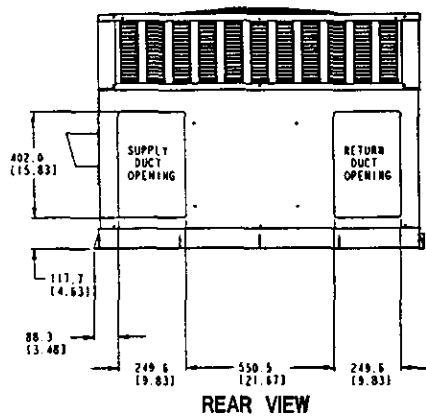

REQ'D CLEARANCES FOR OPERATION AND SERVICING, in. (mm)

| | |
|--|--------------|
| Evaporator coil access side | .36 (914) |
| Power entry side (except for NEC requirements) | .36 (914) |
| Unit top | .48 (1219) |
| Side opposite ducts | .36 (914) |
| Duct panel | .12 (304.8)* |

*Minimum distances: If unit is placed less than 12 in. (304.8 mm) from wall system, then the system performance may be compromised.

LEGEND

- CG - Center of Gravity
 - COND - Condenser
 - EVAP - Evaporator
 - NEC - National Electrical Code
 - REQ'D - Required
- Note: Dimensions are in in. (mm)

REQ'D CLEARANCES TO COMBUSTIBLE MAT'L, in. (mm)

| | |
|---------------------|-------------|
| Top of unit | .14 (355.6) |
| Duct side of unit | .2 (50.8) |
| Side opposite ducts | .14 (355.6) |
| Bottom of unit | .050 (12.7) |
| Flue panel | .36 (914.4) |

NEC REQ'D CLEARANCES, in. (mm)

| | |
|--|--------------|
| Between units, power entry side | .42 (1066.8) |
| Unit and ungrounded surfaces, power entry side | .36 (914) |
| Unit and block or concrete walls and other grounded surfaces, control box side | .42 (1066.8) |

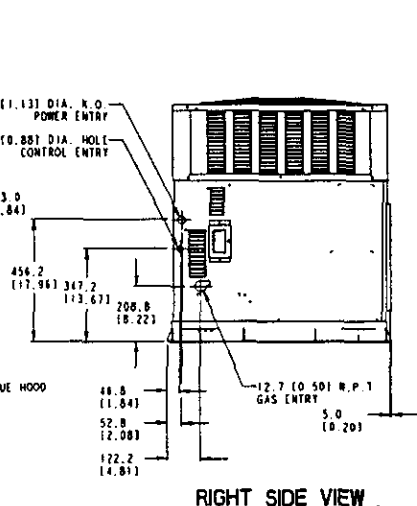
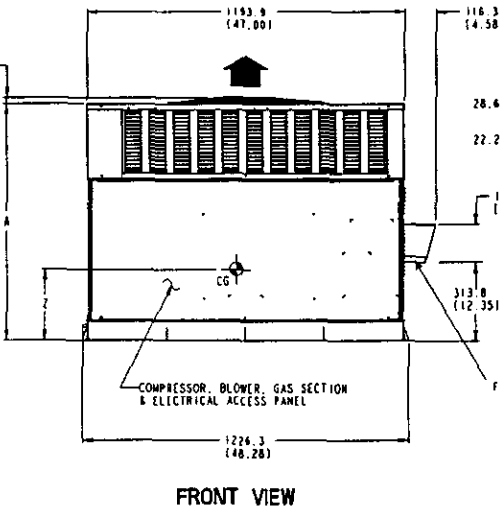
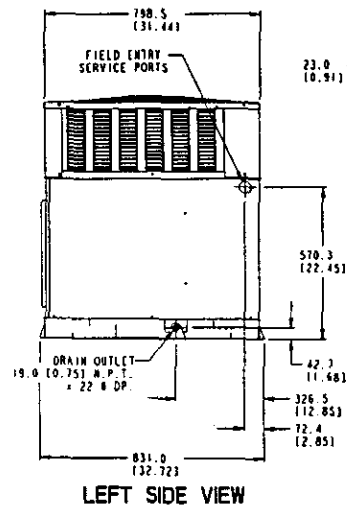

| UNIT | ELECTRICAL CHARACTERISTICS | UNIT WEIGHT | | UNIT HEIGHT IN. (MM) "A" | CENTER OF GRAVITY IN. (MM) | | |
|-----------------|----------------------------|-------------|-------|--------------------------------|-------------------------------|--------------|--------------|
| | | lb | kg | | X | Y | Z |
| 48JZ024-040 | 208/230-1-60 | 310.0 | 141.0 | 35.02 (889.5) | 22.0 (558.8) | 14.5 (368.3) | 16.0 (406.4) |
| 48JZ030-040/060 | 208/230-1-80 | 324.0 | 147.0 | 37.02 (940.3) | 22.0 (558.8) | 15.3 (387.4) | 17.6 (447.0) |
| 48JZ036-060/090 | 208/230-1-60, 208/230-3-60 | 321.0 | 145.6 | 37.02 (940.3) | 22.0 (558.8) | 15.3 (387.4) | 16.5 (419.1) |

Fig. 2—48JZ024-036 Unit Dimensions

Step 3—FIELD FABRICATE DUCTWORK

Secure all ducts to roof curb and building structure on vertical discharge units. *Do not connect ductwork to unit.* For horizontal applications, unit is provided with flanges on the horizontal openings. All ductwork should be secured to the flanges. Insulate and weatherproof all external ductwork, joints, and roof openings with counter flashing and mastic in accordance with applicable codes.

Ducts passing through an unconditioned space must be insulated and covered with a vapor barrier.

If a plenum return is used on a vertical unit, the return should be ducted through the roof deck to comply with applicable fire codes.

A minimum clearance is not required around ductwork. Cabinet return-air static shall not exceed -.25 in. wg.

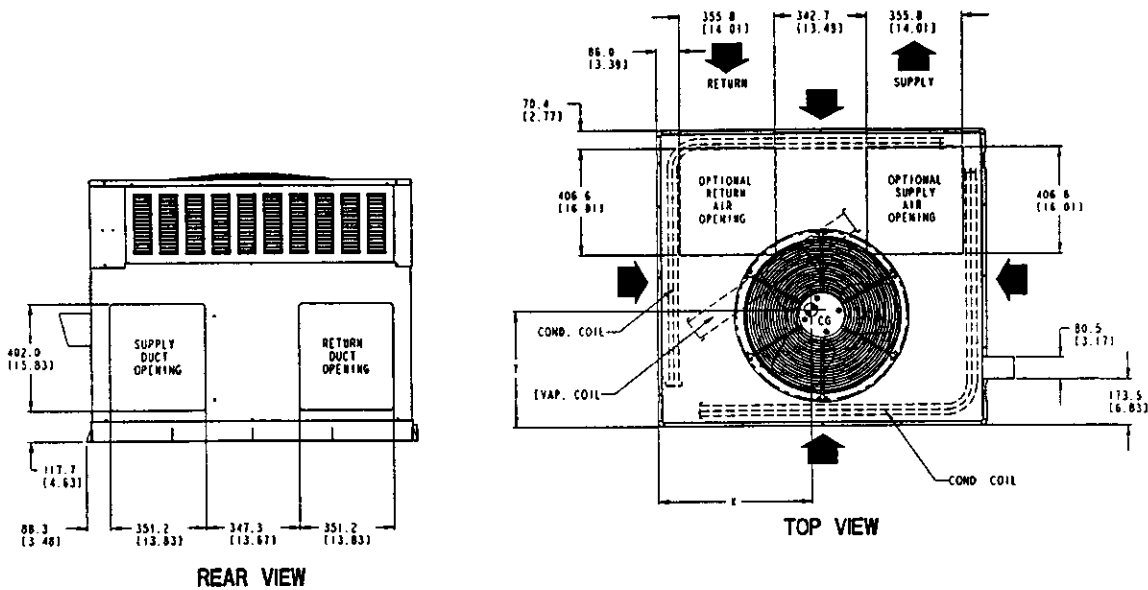

REQUIRED CLEARANCE FOR OPERATION AND SERVICING

| | in. [mm] |
|-------------------------------|---------------|
| EVAP. COIL ACCESS SIDE..... | 36.00 [914.0] |
| POWER ENTRY SIDE..... | 36.00 [914.0] |
| (EXCEPT FOR NEC REQUIREMENTS) | |
| UNIT TOP..... | 36.00 [914.0] |
| SIDE OPPOSITE DUCTS..... | 36.00 [914.0] |
| DUCT PANEL..... | 12.00 [304.8] |

*MINIMUM DISTANCES: IF UNIT IS PLACED LESS THAN 12.00 [304.8] FROM WALL SYSTEM, THEN SYSTEM PERFORMANCE MAYBE COMPROMISE.

REQUIRED CLEARANCE TO COMBUSTIBLE MATL.

| | in. [mm] |
|--------------------------|---------------|
| TOP OF UNIT..... | 14.00 [355.8] |
| DUCT SIDE OF UNIT..... | 2.00 [50.8] |
| SIDE OPPOSITE DUCTS..... | 14.00 [355.8] |
| BOTTOM OF UNIT..... | 0.50 [12.7] |
| FLUE PANEL..... | 36.00 [914.4] |

NEC. REQUIRED CLEARANCES.

| | MILLIMETERS [IN.] |
|---|-------------------|
| BETWEEN UNITS, POWER ENTRY SIDE..... | 42.00 [1066.8] |
| UNIT AND UNGROUNDED SURFACES, POWER ENTRY SIDE..... | 36.00 [914.0] |
| UNIT AND BLOCK OR CONCRETE WALLS AND OTHER GROUNDED SURFACES, POWER ENTRY SIDE..... | 42.00 [1066.8] |

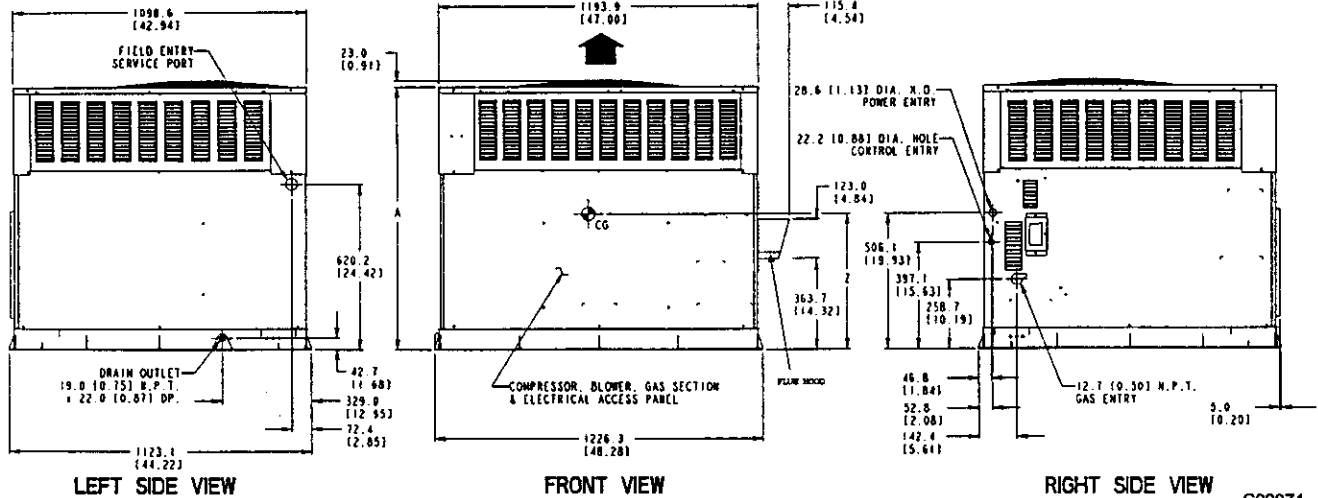

| UNIT | ELECTRICAL CHARACTERISTICS | UNIT WEIGHT | | UNIT HEIGHT IN. (MM) "A" | CENTER OF GRAVITY IN. (MM) | | |
|---------------------|----------------------------|-------------|-----|--------------------------------|-------------------------------|--------------|--------------|
| | | lb | kg | | X | Y | Z |
| 48JZ042-060/090 | 208/230-1-60, 208/230-3-60 | 380 | 172 | 40.98 (1040.9) | 23.0 (584.2) | 16.3 (412.8) | 16.6 (421.6) |
| 48JZ048-090/115/130 | 208/230-1-60, 208/230-3-60 | 409 | 186 | 40.98 (1040.9) | 21.5 (546.1) | 16.6 (422.1) | 18.0 (457.2) |
| 48JZ060-090/115/130 | 208/230-1-60, 208/230-3-60 | 504 | 229 | 42.98 (1091.1) | 23.5 (596.9) | 16.3 (412.8) | 17.6 (447.0) |

Fig. 3—48JZ042-060 Unit Dimensions

Step 4—PROVIDE CLEARANCES

The required minimum operating and service clearances are shown in Fig. 2 and 3. Adequate combustion, ventilation and outdoor coil air must be provided in accordance with section 5.3, Air for Combustion and Ventilation, of the National Fuel Gas Code ANSI (American National Standards Institute) Z223.1 or applicable provisions of local building code. In Canada, follow sections 7.2,

7.3, or 7.4 or Can/CGA. (Canadian Gas Association) B149 Installation Codes or applicable provisions of local building code.

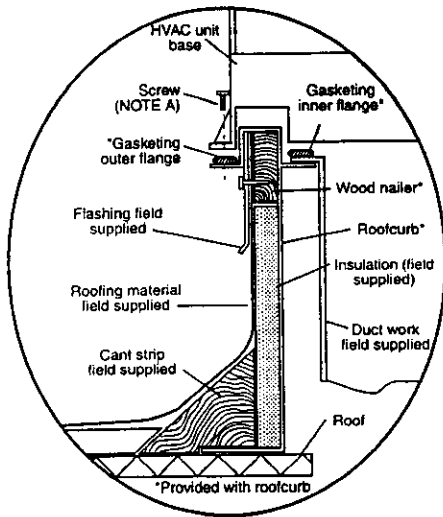

Roof Curb for Small Cabinet

Note A: When unit mounting screw is used, retainer bracket must also be used.

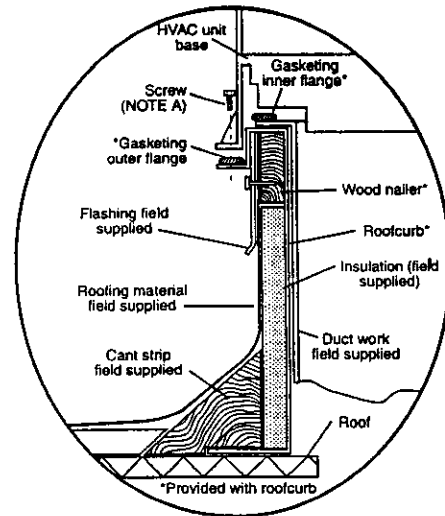

Roof Curb for Large Cabinet

Note A: When unit mounting screw is used, retainer bracket must also be used.

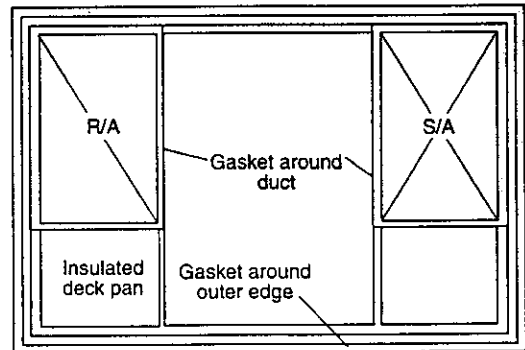
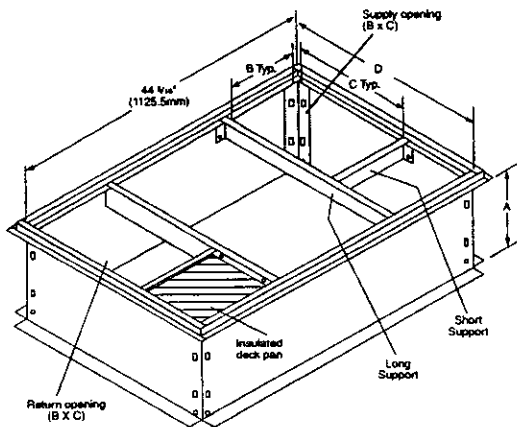

C00076

| UNIT SIZE | ODS CATALOG NUMBER | A IN. (MM) | B IN. (MM) | C IN. (MM) | D IN. (MM) |
|-------------|--------------------|---------------|---------------|---------------|---------------|
| 48JZ024-036 | CPRFCURB006A00 | 8 (203) | 11(279) | 16 1/2 (419) | 28 3/4 (730) |
| | CPRFCURB007A00 | 14 (356) | 11(279) | 16 1/2 (419) | 28 3/4 (730) |
| 48JZ042-060 | CPRFCURB008A00 | 8 (203) | 16 3/16 (411) | 17 3/8 (441) | 40 1/4 (1022) |
| | CPRFCURB009A00 | 14 (356) | 16 3/16 (411) | 17 3/8 (441) | 40 1/4 (1022) |

NOTES:

1. Roof curb must be set up for unit being installed.
2. Seal strip must be applied, as required, to unit being installed.
3. Dimensions in () are in millimeters.
4. Roof curb is made of 16-gage steel.
5. Table lists only the dimensions, per part number, that have changed.
6. Attach ductwork to curb (flanges of duct rest on curb).
7. Insulated panels: 1-in. thick fiberglass 1 lb density.
8. Dimensions are in inches.
9. When unit mounting screw is used (see Note A), a retainer bracket must be used as well. This bracket must also be used when required by code for hurricane or seismic conditions. This bracket is available through Micrometl.



Fig. 4—Roof Curb Dimensions

⚠ CAUTION
Do not restrict outdoor coil airflow. An air restriction at either the outdoor-air inlet or the fan discharge can be detrimental to compressor life.

The outdoor fan pulls air through the outdoor coil and discharges it through the top cover. Be sure that the fan discharge does not recirculate to the outdoor coil. Do not locate the unit in either a

corner or under an overhead obstruction. The minimum clearance under a partial overhang (such as a normal house overhang) is 48-in. above the unit top. The maximum horizontal extension of a partial overhang must not exceed 48-in..

Do not place the unit where water, ice, or snow from an overhang or roof will damage or flood the unit. Do not install the unit on carpeting, tile, or other combustible materials. The unit may be installed on wood flooring or on Class A, B, or C roof covering materials.

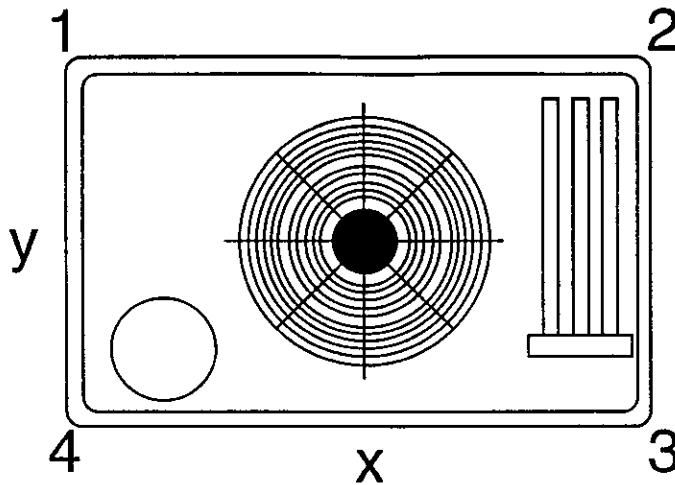

C00070

| CORNER WEIGHTS (SMALL CABINET) | | | | | CORNER WEIGHTS (LARGE CABINET) | | | | |
|--------------------------------|-----------------|-----|-------|-------|--------------------------------|-----------------|-----|-----|-----|
| Model 48JZ | Unit | 024 | 030 | 036 | Model 48JZ | Unit | 042 | 048 | 060 |
| | Total Weight | 310 | 324 | 321 | | Total Weight | 380 | 409 | 504 |
| | Corner Weight 1 | 52 | 60.5 | 61.0 | | Corner Weight 1 | 83 | 108 | 105 |
| | Corner Weight 2 | 88 | 57.3 | 57.8 | | Corner Weight 2 | 52 | 48 | 76 |
| | Corner Weight 3 | 49 | 98.0 | 99.5 | | Corner Weight 3 | 115 | 125 | 130 |
| | Corner Weight 4 | 121 | 108.2 | 102.7 | | Corner Weight 4 | 130 | 128 | 193 |

Fig. 5—48JZ Corner Weights

Step 5—RIG AND PLACE UNIT

⚠ CAUTION

When installing the unit on a rooftop, be sure the roof will support the additional weight.

Use spreader bars or crate top when rigging the unit. The units must be rigged for lifting (See Fig. 6). Refer to Table 1 for operating weight. Use extreme caution to prevent damage when moving the unit. Unit must remain in an upright position during all rigging and moving operations. The unit must be level for proper condensate drainage; therefore, the ground-level pad or accessory roof curb must be level before setting the unit in place. When a field-fabricated support is used, be sure that the support is level and properly supports the unit. Lifting point should be directly over the center of gravity for the unit.

Step 6—CONNECT CONDENSATE DRAIN

NOTE: When installing condensate drain connection be sure to comply with local codes and restrictions.

Model 48JZ disposes of condensate water through a 3/4 in. NPT fitting which exits through the compressor access panel (See Fig. 2 and 3 for location).

Condensate water can be drained directly onto the roof in rooftop installations (where permitted) or onto a gravel apron in ground-level installations. Install a field-supplied condensate trap at end of condensate connection to ensure proper drainage. Make sure that the outlet of the trap is at least 1 in. lower than the drain condensate connection to prevent the drain from overflowing (See Fig. 7). Prime the trap with water. When using a gravel apron, make sure it slopes away from the unit.

If the installation requires draining the condensate water away from the unit, install a 2-in. trap at the condensate connection to ensure proper drainage (See Fig. 7). Make sure that the outlet of the trap is at least 1 in. lower than the drain condensate connection. This prevents the drain from overflowing.

Prime the trap with water. Connect a drain tube – using a minimum of 3/4-in. PVC or 3/4-in. copper pipe (all field-supplied) – at the outlet end of the 2-in. trap. Do not undersize the tube. Pitch the drain tube downward at a slope of at least 1-in. for every 10 ft of horizontal run. Be sure to check the drain tube for leaks.

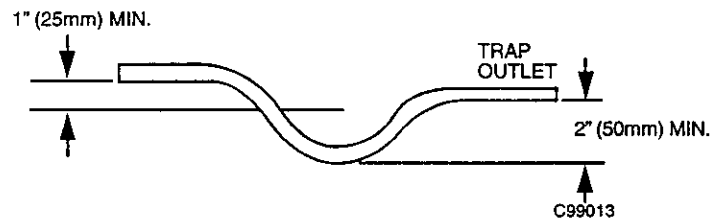

Fig. 7—Condensate Trap

Step 7—INSTALL FLUE HOOD

The flue hood assembly is shipped screwed to the coil panel in the indoor blower compartment. Remove the service access panel to locate the assembly.

⚠ CAUTION

The venting system is designed to ensure proper venting. The flue hood assembly must be installed as indicated in this section of the unit installation instructions.

Install the flue hood as follows:

1. This installation must conform with local building codes and with the National Fuel Gas Code (NFGC), ANSI Z223.1 (in Canada, CAN/CGA B149.1, and B149.2) or NFPA (National Fire Protection Association) latest revision. Refer to Provincial and local plumbing or wastewater codes and other applicable local codes.
2. Remove flue hood from shipping location (inside the blower compartment). Place vent cap assembly over flue panel. Orient

Table 1—Physical Data—Unit 48JZ

| UNIT SIZE 48JZ | 024040 | 030040 | 030060 | 036060 | 036090 | 042060 | 042090 |
|--|--------------------------|-------------------------|-------------------------|--------------------------|--------------------------|-------------------------|--------------------------|
| NOMINAL CAPACITY (ton) | 2 | 2-1/2 | 2-1/2 | 3 | 3 | 3-1/2 | 3-1/2 |
| OPERATING WEIGHT (lb.) | 310 | 324 | 324 | 321 | 321 | 380 | 380 |
| COMPRESSORS Quantity | Scroll 1 | | | | | | |
| REFRIGERANT (R-410A) Quantity (lb.) | 7.0 | 8.9 | 8.9 | 9.3 | 9.3 | 9.5 | 9.5 |
| REFRIGERANT METERING DEVICE Orifice ID (In.) AccuRater Piston | 0.061 | 0.061 | 0.061 | 0.067 | 0.067 | 0.073 | 0.073 |
| Orifice OD (In.) | 0.032 (2) | 0.040 (2) | 0.040 (2) | 0.040 (2) | 0.040 (2) | 0.038 (2) | 0.038 (2) |
| OUTDOOR COIL Rows...Fins/In. Face Area (sq ft) | 2...17 8.5 | 2...17 10.3 | 2...17 10.3 | 2...17 10.3 | 2...17 10.3 | 2...17 13.5 | 2...17 13.5 |
| OUTDOOR FAN Nominal Cfm Diameter (In.) Motor HP (Rpm) | 2350 22 1/8 (825) | 2350 22 1/8 (825) | 2350 22 1/8 (825) | 2800 22 1/4 (1100) | 2800 22 1/4 (1100) | 2500 22 1/8 (825) | 2500 22 1/8 (1100) |
| INDOOR COIL Rows...Fins/In. Face Area (sq ft) | 3...15 3.7 | 3...15 3.7 | 3...15 3.7 | 4...15 3.7 | 4...15 3.7 | 3...15 4.7 | 3...15 4.7 |
| INDOOR BLOWER (Standard PSC Motor) Nominal Airflow (Cfm) Size (In.) Motor (HP) | 800 10 X 10 1/4 | 1000 10 X 10 1/4 | 1000 10 X 10 1/4 | 1200 10 X 10 1/2 | 1200 10 X 10 1/2 | 1400 11 X 10 1/2 | 1400 11 X 10 1/2 |
| FURNACE SECTION* Burner Orifice No. (Qty...Drill Size) Natural Gas Burner Orifice No. (Qty...Drill Size) Propane Gas | 2...44 2...50 | 2...44 2...50 | 2...38 2...46 | 2...38 2...46 | 3...38 3...46 | 2...38 2...46 | 3...38 3...46 |
| HIGH-PRESSURE SWITCH (psig) Cut-out Reset (Auto) | 610 +/- 15 420 +/- 25 | | | | | | |
| LOSS-OF-CHARGE / LOW-PRESSURE SWITCH (Liquid Line) (psig) Cut-out Reset (auto) | 20 +/- 5 45 +/- 10 | | | | | | |
| RETURN-AIR FILTERS (in.)† Throwaway | 20 x 20 x 1 | 20 x 20 x 1 | 20 x 24 x 1 | 20 x 24 x 1 | 20 x 24 x 1 | 24 x 30 x 1 | 24 x 30 x 1 |

* Based on altitude of 0 to 2000 ft.

† Required filter sizes shown are based on the larger of the ARI (Air Conditioning and Refrigeration Institute) rated cooling airflow or the heating airflow velocity of 300 fpm/minute for high-capacity type. Air filter pressure drop for non-standard filters must not exceed 0.08 in. wg.

screw holes in vent cap with holes in the flue panel.

- Secure flue hood to flue panel by inserting a single screw on the right side and the left side of the hood.

Step 8—INSTALL GAS PIPING

The gas supply pipe enters the unit through the access hole provided. The gas connection to the unit is made to the 1/2-in. FPT gas inlet on the manual shutoff or gas valve.

Install a gas supply line that runs to the heating section. Refer to Table 2 and the NFGC for gas pipe sizing. *Do not use cast-iron pipe.* It is recommended that a black iron pipe is used. Check the local utility for recommendations concerning existing lines. Size gas supply piping for 0.5 in. wg maximum pressure drop. *Never use pipe smaller than the 1/2-in. FPT gas inlet on the unit gas valve.*

For natural gas applications, the gas pressure at unit gas connection must not be less than 4.0 in. wg or greater than 13 in. wg while the unit is operating. For propane applications, the gas pressure must not be less than 7.0 in. wg or greater than 13 in. wg at the unit connection.

An 1/8-in. NPT plugged tapping, accessible for test gage connection, must be installed immediately upstream of the gas supply connection to the gas valve.

When installing the gas supply line, observe local codes pertaining to gas pipe installations. Refer to the NFGC ANSI Z223.1 NFPA 54 latest edition (in Canada, CAN/CGA B149.1, latest edition). In the absence of local building codes, adhere to the following pertinent recommendations:

- Avoid low spots in long runs of pipe. Grade all pipe 1/4 in. in every 15 ft to prevent traps. Grade all horizontal runs downward to risers. Use risers to connect to heating section and to meter.
- Protect all segments of piping system against physical and thermal damage. Support all piping with appropriate straps, hangers, etc. Use a minimum of one hanger every 6 ft. For pipe sizes larger than 1/2 in., follow recommendations of national codes.
- Apply joint compound (pipe dope) sparingly and only to male threads of joint when making pipe connections. Use only pipe dope that is resistant to action of liquefied petroleum gases as specified by local and/or national codes. *Never use Teflon tape.*
- Install sediment trap in riser leading to heating section. (See Fig. 8). This drip leg functions as a trap for dirt and condensate.

Table 1—Physical Data—Unit 48JZ (Continued)

| UNIT SIZE 48JZ | 048090 | 048115 | 048130 | 060090 | 060115 | 060130 |
|---|--------------------------|--------------------------|--------------------------|--------------------------|--------------------------|--------------------------|
| NOMINAL CAPACITY (ton) | 4 | 4 | 4 | 5 | 5 | 5 |
| OPERATING WEIGHT (lb.) | 409 | 409 | 409 | 504 | 504 | 504 |
| COMPRESSORS | Scroll | | | | | |
| Quantity | 1 | | | | | |
| REFRIGERANT (R-410A) Quantity (lb.) | 10.6 | 10.6 | 10.6 | 12.4 | 12.4 | 12.4 |
| REFRIGERANT METERING DEVICE | | | | | | |
| Orifice ID (In.) AccuRater | 0.076 | 0.076 | 0.076 | 0.088 | 0.088 | 0.088 |
| Orifice OD (In.) | 0.046 (2) | 0.046 (2) | 0.046 (2) | 0.052 (2) | 0.052 (2) | 0.052 (2) |
| OUTDOOR COIL | | | | | | |
| Rows...Fins/in. Face Area (sq ft) | 2...17 13.5 | 2...17 13.5 | 2...17 13.5 | 2...17 15.4 | 2...17 15.4 | 2...17 15.4 |
| OUTDOOR FAN | | | | | | |
| Nominal Cfm Diameter (In.) Motor HP (Rpm) | 3300 22 1/4 (1100) | 3300 22 1/4 (1100) | 3300 22 1/4 (1100) | 3300 22 1/4 (1100) | 3300 22 1/4 (1100) | 3300 22 1/4 (1100) |
| INDOOR COIL | | | | | | |
| Rows...Fins/in. Face Area (sq ft) | 4...15 4.7 | 4...15 4.7 | 4...15 4.7 | 4...15 5.7 | 4...15 5.7 | 4...15 5.7 |
| INDOOR BLOWER (Standard PSC Motor) | | | | | | |
| Nominal Airflow (Cfm) Size (In.) Motor (HP) | 1600 11 X 10 1/2 | 1600 11 X 10 1/2 | 1600 11 X 10 1/2 | 1750 11 X 10 1.0 | 1750 11 X 10 1.0 | 1750 11 X 10 1.0 |
| FURNACE SECTION* | | | | | | |
| Burner Orifice No. (Qty...Drill Size) Natural Gas | 3...38 3...46 | 3...33 3...42 | 3...31 3...41 | 3...38 3...46 | 3...33 3...42 | 3...31 3...41 |
| Burner Orifice No. (Qty...Drill Size) Propane Gas | | | | | | |
| HIGH-PRESSURE SWITCH (psig) | | | | | | |
| Cut-out Reset (Auto) | 610 +/- 15 420 +/- 25 | | | | | |
| LOSS-OF-CHARGE / LOW-PRESSURE SWITCH (Liquid Line) (psig) | | | | | | |
| Cut-out Reset (auto) | 20 +/- 5 45 +/- 10 | | | | | |
| RETURN-AIR FILTERS (In.)† Throwaway | 24 x 30 x 1 | 24 x 30 x 1 | 24 x 30 x 1 | 24 x 30 x 1 | 24 x 30 x 1 | 24 x 30 x 1 |

* Based on altitude of 0 to 2000 ft.

† Required filter sizes shown are based on the larger of the ARI (Air Conditioning and Refrigeration Institute) rated cooling airflow or the heating airflow velocity of 300 ft/minute for high-capacity type. Air filter pressure drop for non-standard filters must not exceed 0.08 in. wg.

Table 2—Maximum Gas Flow Capacity*

| NOMINAL IRON PIPE, SIZE (IN.) | INTERNAL DIAMETER (IN.) | LENGTH OF PIPE, FT† | | | | | | | | | | | | | |
|--|-------------------------------|---------------------|------|------|-----|-----|-----|-----|-----|-----|-----|-----|-----|-----|-----|
| | | 10 | 20 | 30 | 40 | 50 | 60 | 70 | 80 | 90 | 100 | 125 | 150 | 175 | 200 |
| 1/2 | .622 | 175 | 120 | 97 | 82 | 73 | 66 | 61 | 57 | 53 | 50 | 44 | 40 | — | — |
| 3/4 | .824 | 360 | 250 | 200 | 170 | 151 | 138 | 125 | 118 | 110 | 103 | 93 | 84 | 77 | 72 |
| 1 | 1.049 | 680 | 465 | 375 | 320 | 285 | 260 | 240 | 220 | 205 | 195 | 175 | 160 | 145 | 135 |
| 1 1/4 | 1.380 | 1400 | 950 | 770 | 600 | 580 | 530 | 490 | 460 | 430 | 400 | 360 | 325 | 300 | 280 |
| 1 1/2 | 1.610 | 2100 | 1460 | 1180 | 990 | 900 | 810 | 750 | 690 | 650 | 620 | 550 | 500 | 460 | 430 |

* Capacity of pipe in cu ft of gas per hr for gas pressure of 0.5 psig or less. Pressure drop of 0.5-in. wg (based on a 0.60 specific gravity gas). Refer to Table, National Fire Protection Association NFPA 54.

† This length includes an ordinary number of fittings.

5. Install an accessible, external, manual main shutoff valve in gas supply pipe within 6 ft of heating section.
6. Install ground-joint union close to heating section between unit manual shutoff and external manual main shut-off valve.
7. Pressure-test all gas piping in accordance with local and national plumbing and gas codes before connecting piping to unit.

NOTE: Pressure test the gas supply system *after* the gas supply piping is connected to the gas valve. The supply piping must be disconnected from the gas valve during the testing of the piping systems when test pressure is in excess of 0.5 psig. Pressure test the gas supply piping system at pressures equal to or less than 0.5 psig. The unit heating section must be isolated from the gas piping system by closing the external main manual shutoff valve and slightly opening the ground-joint union.

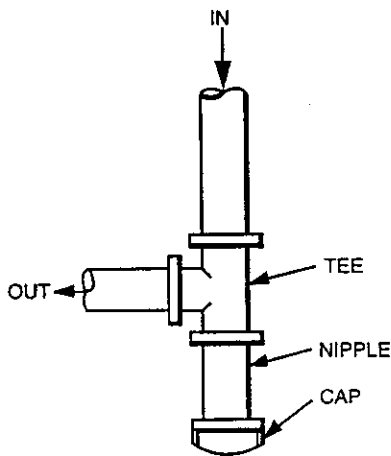

C99020

Fig. 8—Sediment Trap

⚠ CAUTION

Unstable operation may occur when the gas valve and manifold assembly are forced out of position while connecting improperly-routed rigid gas piping to the gas valve. Use a backup wrench on the square neck of the inlet side of the gas valve when making connection to avoid strain on, or distortion of, the gas control piping.

⚠ CAUTION

If a flexible conductor is required or allowed by the authority having jurisdiction, black iron pipe shall be installed at the gas valve and shall extend a minimum of 2 in. outside the unit casing.

⚠ WARNING

Never use a match or other open flame when checking for gas leaks. Never purge gas line into combustion chamber. Failure to follow this warning could result in an explosion causing serious injury or death.

8. Check for gas leaks at the field-installed and factory-installed gas lines after all piping connections have been completed. Use soap-and-water solution (or method specified by local codes and/or regulations).

Step 9—INSTALL DUCT CONNECTIONS

The unit has duct flanges on the supply- and return-air openings on the side and bottom of the unit. For downshot applications, the ductwork connects to the roof curb (See Fig. 2 and 3 for connections sizes and locations).

CONFIGURING UNITS FOR DOWNFLOW (VERTICAL) DISCHARGE

⚠ WARNING

Before performing service or maintenance operations on the system, turn off main power to unit and install lock-out tag. Electrical shock could cause serious injury or death.

1. Open all electrical disconnects before starting any service work.
2. Remove horizontal duct covers to access bottom return and supply knockout panels.

3. Use a screwdriver and hammer to remove the panels in the bottom of the unit base (See Fig. 9 & 10).

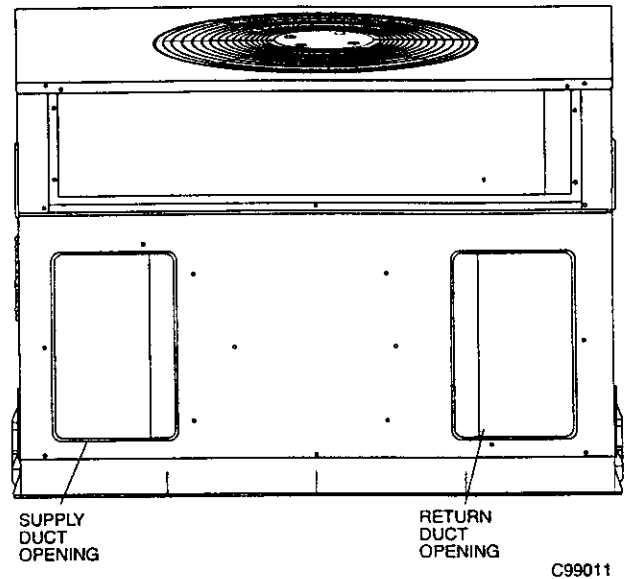

C99011

Fig. 9—Supply and Return Duct Opening

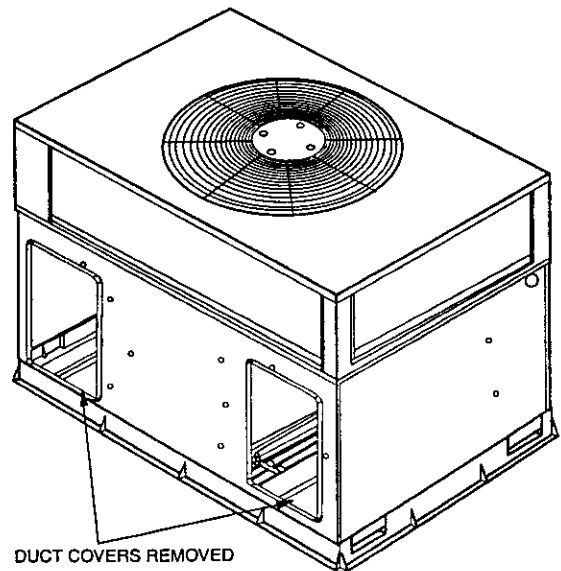

C99012

Fig. 10—Vertical Duct Cover Removed

4. If unit ductwork is to be attached to vertical opening flanges on the unit base (jackstand applications only), do so at this time.

⚠ CAUTION

Collect ALL screws that were removed. Do not leave screws on rooftop as permanent damage to the roof may occur.

5. It is recommended that the base insulation around the perimeter of the vertical return-air opening be secured to the base with aluminum tape. Applicable local codes may require aluminum tape to prevent exposed fiberglass.
6. Cover both horizontal duct openings with the provided duct covers. Ensure opening is air- and watertight.

- After completing unit conversion, perform all safety checks and power up unit.

NOTE: The design and installation of the duct system must be in accordance with the standards of the NFPA for installation of nonresidence-type air conditioning and ventilating systems, NFPA 90A or residence-type, NFPA 90B; and/or local codes and ordinances.

Adhere to the following criteria when selecting, sizing, and installing the duct system:

- Units are shipped for horizontal duct installation (by removing duct covers).
- Select and size ductwork, supply-air registers, and return-air grilles according to American Society of Heating, Refrigeration and Air Conditioning Engineers (ASHRAE) recommendations.
- Size all ductwork for maximum required airflow (either heating or cooling) for unit being installed. Avoid abrupt duct size increases or decreases or performance may be affected.
- Adequately insulate and weatherproof all ductwork located outdoors. Insulate ducts passing through unconditioned space, and use vapor barrier in accordance with latest issue of Sheet Metal and Air Conditioning Contractors National Association (SMACNA) and Air Conditioning Contractors of America (ACCA) minimum installation standards for heating and air conditioning systems. Secure all ducts to building structure.
- Use flexible transition between rigid ductwork and unit to prevent transmission of vibration. The transition may be screwed or bolted to duct flanges. Use suitable gaskets to ensure weathertight and airtight seal.
- All units must have field-supplied filters or accessory filter rack installed in the return-air side of the unit. Recommended sizes for filters are shown in Table 1.
- Flash, weatherproof, and vibration-isolate all openings in building structure in accordance with local codes and good building practices.

Step 10—INSTALL ELECTRICAL CONNECTIONS

⚠ WARNING

The unit cabinet must have an uninterrupted, unbroken electrical ground to minimize the possibility of personal injury if an electrical fault should occur. This ground may consist of an electrical wire connected to the unit ground lug in the control compartment, or conduit approved for electrical ground when installed in accordance with NEC (National Electrical Code) ANSI/NFPA 70 (latest edition) and local electrical codes. In Canada, follow Canadian Electrical Code CSA (Canadian Standards Association) C22.1 and local electrical codes. Failure to adhere to this warning could result in serious injury or death.

⚠ CAUTION

Failure to follow these precautions could result in damage to the unit being installed:

- Make all electrical connections in accordance with NEC ANSI/NFPA 70 (latest edition) and local electrical codes governing such wiring. In Canada, all electrical connections must be in accordance with CSA standard C22.1 Canadian Electrical Code Part 1 and applicable local codes. Refer to unit wiring diagram.
- Use only *copper* conductor for connections between field-supplied electrical disconnect switch and unit. **DO NOT USE ALUMINUM WIRE.**
- Be sure that high-voltage power to unit is within operating voltage range indicated on unit rating plate.
- Do not damage internal components when drilling through any panel to mount electrical hardware, conduit, etc. On 3-phase units, ensure phases are balanced within 2 percent. Consult local power company for correction of improper voltage and/or phase imbalance.

HIGH-VOLTAGE CONNECTIONS

The unit must have a separate electrical service with a field-supplied, waterproof, disconnect switch mounted at, or within sight from, the unit. Refer to the unit rating plate for maximum fuse/circuit breaker size and minimum circuit amps (ampacity) for wire sizing. (See Table 3 for electrical data.)

The field-supplied disconnect switch box may be mounted on the unit over the high-voltage inlet hole when the standard power and low-voltage entry points are used (See Fig. 2 and 3 for acceptable location).

See unit wiring label and Fig. 11 for reference when making high voltage connections. Proceed as follows to complete the high-voltage connections to the unit.

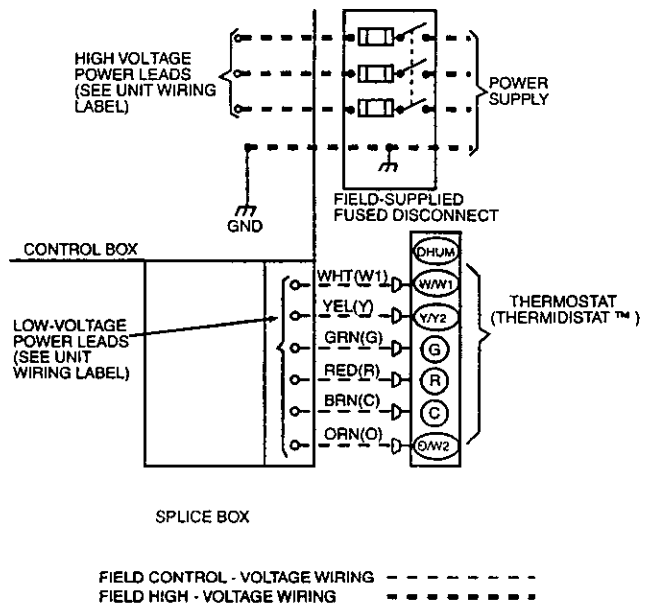

Fig. 11—High- and Control-Voltage Connections

Single phase units:

- Run the high-voltage (L1, L2) and ground leads into the control box.
- Connect ground lead to chassis ground connection.

Table 3—Electrical Data—Unit 48JZ

| UNIT SIZE 48JZ | V-PH-HZ | VOLTAGE RANGE | | COMPRESSOR | | OUTDOOR FAN MOTOR | INDOOR FAN MOTOR | POWER SUPPLY | |
|-------------------|--------------|---------------|-----|------------|-------|-------------------|------------------|--------------|---------------------|
| | | Min | Max | RLA | LRA | FLA | FLA | MCA | MAX FUSE OR CKT BKR |
| 024 | 208/230-1-60 | 187 | 253 | 13.5 | 61.0 | 0.9 | 2.0 | 19.8 | 30 |
| 030 | 208/230-1-60 | 187 | 253 | 15.9 | 73.0 | 0.9 | 2.1 | 22.9 | 35 |
| 036 | 208/230-1-60 | 187 | 253 | 16.9 | 83.0 | 1.6 | 4.1 | 26.8 | 40 |
| | 208/230-3-60 | 187 | 253 | 12.2 | 77.0 | 1.6 | 4.1 | 21.0 | 30 |
| 042 | 208/230-1-60 | 187 | 253 | 22.4 | 105.0 | 0.9 | 4.1 | 33.0 | 50 |
| | 208/230-3-60 | 187 | 253 | 15.4 | 88.0 | 0.9 | 4.1 | 24.3 | 35 |
| 048 | 208/230-1-60 | 187 | 253 | 21.3 | 109.0 | 1.6 | 4.1 | 32.3 | 50 |
| | 208/230-3-60 | 187 | 253 | 14.7 | 91.0 | 1.6 | 4.1 | 24.1 | 35 |
| 060 | 208/230-1-60 | 187 | 253 | 27.6 | 158.0 | 1.5 | 6.2 | 42.2 | 60 |
| | 208/230-3-60 | 187 | 253 | 19.2 | 137.0 | 1.5 | 6.2 | 31.7 | 40 |

3. Locate the black and yellow wires connected to the line side of the contactor.
4. Connect L1 to black wire on connection 11 of the compressor contactor.
5. Connect L2 to yellow wire on connection 23 of the compressor contactor.

Three-phase units:

1. Run the high-voltage (L1, L2, L3) and ground leads into the control box.
2. Connect ground lead to chassis ground connection.
3. Locate the black and yellow wires connected to the lines side of the contactor.
4. Connect field L1 to black wire on connection 11 of the compressor contactor.
5. Connect field wire L2 to yellow wire on connection 13 of the compressor contactor.
6. Connect field wire L3 to Blue wire from compressor.

SPECIAL PROCEDURES FOR 208-V OPERATION

▲ WARNING

Before making any wiring changes, **make sure** the gas supply is switched off first. *Then* switch off the power supply to the unit and install lock-out tag. Electrical shock can cause serious injury or death.

CONTROL VOLTAGE CONNECTIONS

NOTE: This unit must be installed with either a Thermidistat™ or Dual fuel thermostat for proper system operation.

Do not use any type of power-stealing thermostat (no Common "C" connection at Stat). Unit control problems may result.

Use no. 18 American Wire Gage (AWG) color-coded, insulated (35 C minimum) wires to make the control voltage connections between the thermostat and the unit. If the thermostat is located more than 100 ft from the unit (as measured along the control voltage wires), use no. 16 AWG color-coded, insulated (35 C minimum) wires.

Dual fuel thermostat or Thermidistat™ control is required for proper operation of the dual fuel heat pump unit. Be sure to follow the instructions supplied with the thermostat and control.

Standard Connection

Remove knockout hole located in the flue panel adjacent to the control access panel (See Fig. 2 and 3). Remove the rubber grommet from the installer's packet (included with unit) and install grommet in the knockout opening. Provide a drip loop before running wire through panel.

Run the low-voltage leads from the thermostat, through the inlet hole, and into unit low-voltage splice box.

Locate five 18-gage wires leaving control box. These low-voltage connection leads can be identified by the colors red, green, yellow, brown, and white (See Fig. 11). Ensure the leads are long enough to be routed into the low-voltage splice box (located below right side of control box). Stripped yellow wire is located in connection box. Route leads through hole in bottom of control box and make low-voltage connections (See Fig. 11). Secure all cut wires, so that they do not interfere with operation of unit.

HEAT ANTICIPATOR SETTING

The room thermostat heat anticipator must be properly adjusted to ensure proper heating performance. Set the heat anticipator, using an ammeter between the W and R terminals to determine the exact required setting.

NOTE: For thermostat selection purposes, use 0.18 amp for the approximate required setting. Failure to make a proper heat anticipator adjustment will result in improper operation, discomfort to the occupants of the conditioned space, and inefficient energy utilization; however, the required setting may be changed slightly to provide a greater degree of comfort for a particular installation.

TRANSFORMER PROTECTION

The transformer is of the energy-limiting type. It is set to withstand a 30-sec. overload or shorted secondary condition.

- LEGEND**
- FLA — Full Load Amps
 - LRA — Locked Rotor Amps
 - MCA — Minimum Circuit Amps
 - CKT BKR — Circuit Breaker
 - RLA — Rated Load Amps



NOTES:

1. In compliance with NEC (National Electrical Code) requirements for multimotor and combination load equipment (refer to NEC Articles 430 and 440), the overcurrent protective device for the unit shall be Power Supply fuse. Canadian units may be fuse or circuit breaker.
2. Minimum wire size is based on 60 C copper wire. If other than 60 C wire is used, or if length exceeds wire length in table, determine size from NEC.
3. Unbalanced 3-Phase Supply Voltage
Never operate a motor where a phase imbalance in supply voltage is greater than 2%. Use the following formula to determine the percentage of voltage imbalance.

% Voltage imbalance

$$= 100 \times \frac{\text{max voltage deviation from average voltage}}{\text{average voltage}}$$

EXAMPLE: Supply voltage is 230-3-60.

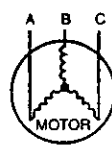

AB = 232 v
BC = 227 v
AC = 225 v

$$\begin{aligned} \text{Average Voltage} &= \frac{232 + 227 + 225}{3} \\ &= \frac{684}{3} \\ &= 228 \end{aligned}$$

Determine maximum deviation from average voltage.

(AB) 232 - 228 = 4 v
(BC) 228 - 227 = 1 v
(AC) 228 - 225 = 3 v

Maximum deviation is 4 v.

Determine percent of voltage imbalance.

$$\begin{aligned} \% \text{ Voltage Imbalance} &= 100 \times \frac{4}{228} \\ &= 1.75\% \end{aligned}$$

This amount of phase imbalance is satisfactory as it is below the maximum allowable 2%.

IMPORTANT: If the supply voltage phase imbalance is more than 2%, contact your local electric utility company immediately.

C01106

Table 4—Legend

PRE-START-UP

⚠ WARNING

Failure to observe the following warnings could result in serious injury or death:

1. Follow recognized safety practices and wear protective goggles when checking or servicing refrigerant system.
2. Do not operate compressor or provide any electric power to unit unless compressor terminal cover is in place and secured.
3. Do not remove compressor terminal cover until all electrical sources are disconnected and tagged.
4. Relieve and recover all refrigerant from system before touching or disturbing anything inside terminal box if refrigerant leak is suspected around compressor terminals.
5. Never attempt to repair brazed connection while refrigerant system is under pressure.
6. Do not use torch to remove any component. System contains oil and refrigerant under pressure. To remove a component, wear protective goggles and proceed as follows:
 - a. Shut off gas supply and *then* electrical power to unit and install lock-out tag.
 - b. Relieve and recover all refrigerant from system using both high- and low-pressure ports.
 - c. Cut component connecting tubing with tubing cutter and remove component from unit.
 - d. Carefully unsweat remaining tubing stubs when necessary. Oil can ignite when exposed to torch flame.

Proceed as follows to inspect and prepare the unit for initial startup:

1. Remove access panel.
2. Read and follow instructions on all WARNING, CAUTION, and INFORMATION labels attached to, or shipped with, unit.
3. Make the following inspections:
 - a. Inspect for shipping and handling damages such as broken lines, loose parts, disconnected wires, etc.

- b. Inspect for oil at all refrigerant tubing connections and on unit base. Detecting oil generally indicates a refrigerant leak.
 - c. Leak test all refrigerant tubing connections using electronic leak detector, halide torch, or liquid-soap solution. If a refrigerant leak is detected, see the *Check for Refrigerant Leaks* section.
 - d. Inspect all field- and factory-wiring connections. Be sure that connections are completed, not rubbing against any sharp sheet metal edges or refrigerant tubing and are tight.
 - e. Inspect coil fins. If damaged during shipping and handling, carefully straighten fins with a fin comb.
4. Verify the following conditions:

⚠ CAUTION

Do not purge gas supply into the combustion chamber. Do not use a match or other open flame to check for gas leaks. Failure to follow this warning could result in an explosion causing serious injury or death.

- a. Make sure gas line is free of air. Before lighting the unit for the first time, perform the following with the gas valve in the "OFF" position:

If the gas supply pipe was not purged before connecting the unit, it will be full of air. It is recommended that the ground joint union be loosened, and the supply line be allowed to purge until the odor of gas is detected. Never purge gas lines into a combustion chamber. Immediately upon detection of gas odor, retighten the union. Allow 5 minutes to elapse, then light unit.
- b. Make sure that outdoor fan blade is correctly positioned in fan orifice. Leading edge of outdoor fan blade should be 1/2 in. maximum from fan orifice.
- c. Ensure fan hub is 1/8 in. maximum from motor housing (See Fig. 12).
- d. Make sure that air filter(s) is in place.
- e. Make sure that condensate drain trap is filled with water to ensure proper drainage.

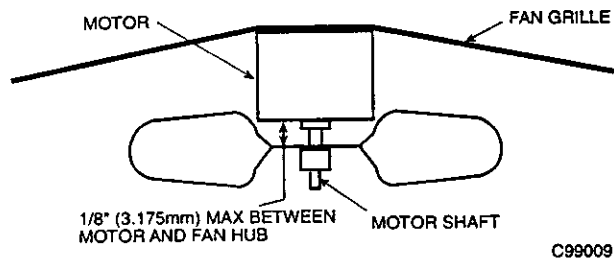

Fig. 12—Fan Blade Clearance

- f. Make sure that all tools and miscellaneous loose parts have been removed.
5. Compressors are internally spring mounted. Do not loosen or remove compressor hold-down bolts.
6. Each unit has 2 schrader-type ports, one low-side located on the suction line, and one high-side located on the compressor discharge line. Be sure that caps on these ports are tight.
7. This unit has *High Flow Valves* located on the compressor hot gas and suction tubes. Large black plastic caps with O-rings distinguish these valves. These valves cannot be accessed for service in the field. Ensure the plastic caps are in place and tight or the possibility of a refrigerant leak could occur.

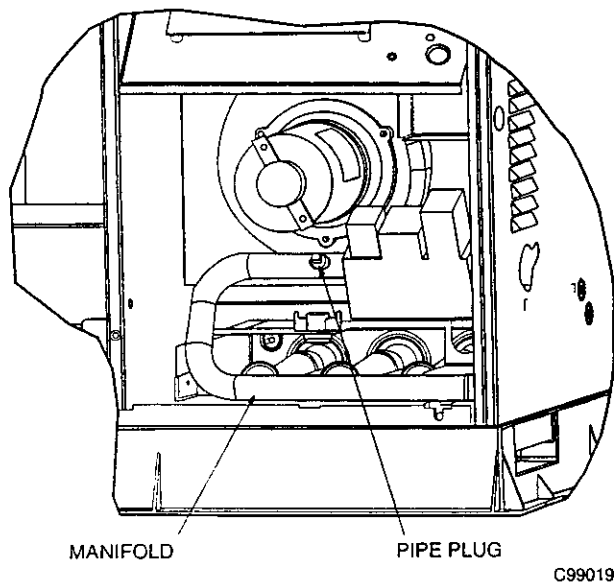

Fig. 13—Burner Assembly

START-UP

Step 1—CHECK FOR REFRIGERANT LEAKS

Proceed as follows to locate and repair a refrigerant leak and to charge the unit:

1. Locate leak and make sure that refrigerant system pressure has been relieved and reclaimed from both high- and low-pressure ports.
2. Repair leak following Refrigerant Service procedures.

NOTE: Install a bi-flow filter drier suitable for use with Puron® (R-410A) whenever the system has been opened for repair.

3. Add a small charge of R-410A refrigerant vapor to system and leak-test unit.
4. Recover refrigerant and evacuate system to 500 Microns if additional leaks are not found.

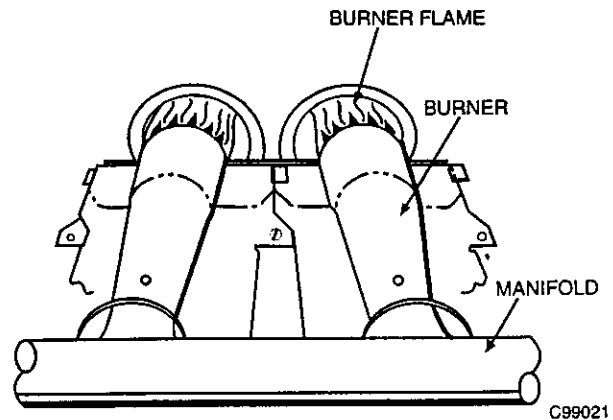

Fig. 14—Monoport Burner

5. Charge unit with R-410A refrigerant, using a volumetric-charging cylinder or accurate scale. Refer to unit rating plate for required charge. Be sure to add extra refrigerant to compensate for internal volume of filter drier.

Step 2—START-UP HEAT AND MAKE ADJUSTMENTS

⚠ CAUTION

Complete the required procedures given in the *Pre-Start-Up* section before starting the unit.

NOTE: This unit is factory equipped with natural gas orifices.

Do not jumper any safety devices when operating the unit.

Make sure that burner orifices are properly aligned. Unstable operation may occur when the burner orifices in the manifold are misaligned.

Follow the lighting instructions on the heating section operation label (located inside the burner or blower access door) to start the heating section.

NOTE: Make sure that gas supply has been purged, and that all gas piping has been checked for leaks.

CHECK HEATING CONTROL

Start and check the unit for proper cooling control operation as follows (see furnace lighting instructions located inside burner or blower access panel):

1. Place room thermostat SYSTEM switch in the HEAT position and the fan switch is placed in AUTO. position. Verify that the outdoor air sensor setting is above the outdoor temperature.
2. Set the heating temperature control of the thermostat above room temperature.
3. The induced-draft motor will start.
4. After a call for heating, the main burner should light within 5 sec. If the burners do not light, there is a 22-sec. delay before another 5-sec. try. If the burners still do not light, this sequence is repeated. If the burners do not light within 15 minutes from the initial call for heat, there is a lockout. To reset the control, break the 24-v power to W.
5. The indoor fan will turn on 45 sec. after the flame has been established. The indoor fan will turn off 45 sec. after the thermostat has been satisfied.

CHECK GAS INPUT

Check gas input and manifold pressure after unit start-up (See Table 5). If adjustment is required proceed as follows:

- The rated gas inputs shown in Table 5 are for altitudes from sea level to 2000 ft above sea level. These inputs are based on

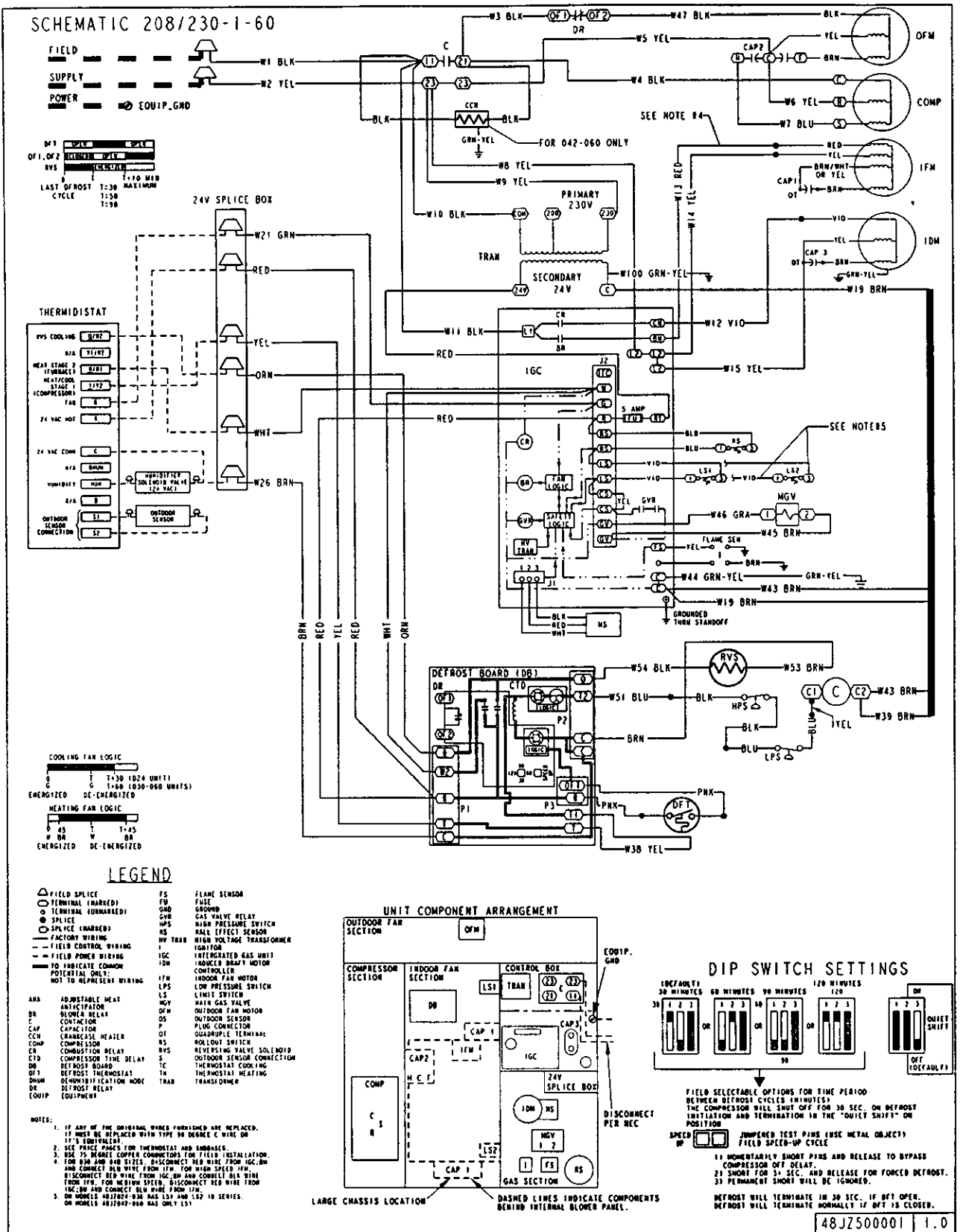

Fig. 15—208/230-1-60 Wiring Diagram, Unit 48JZ

natural gas with a heating value of 1050 Btu/ft³ at 0.65 specific gravity, or propane gas with a heating value of 2500 Btu/ft³ at 1.5 specific gravity.

- For elevations above 2000 ft, reduce input 4 percent for each 1000 ft above sea level.

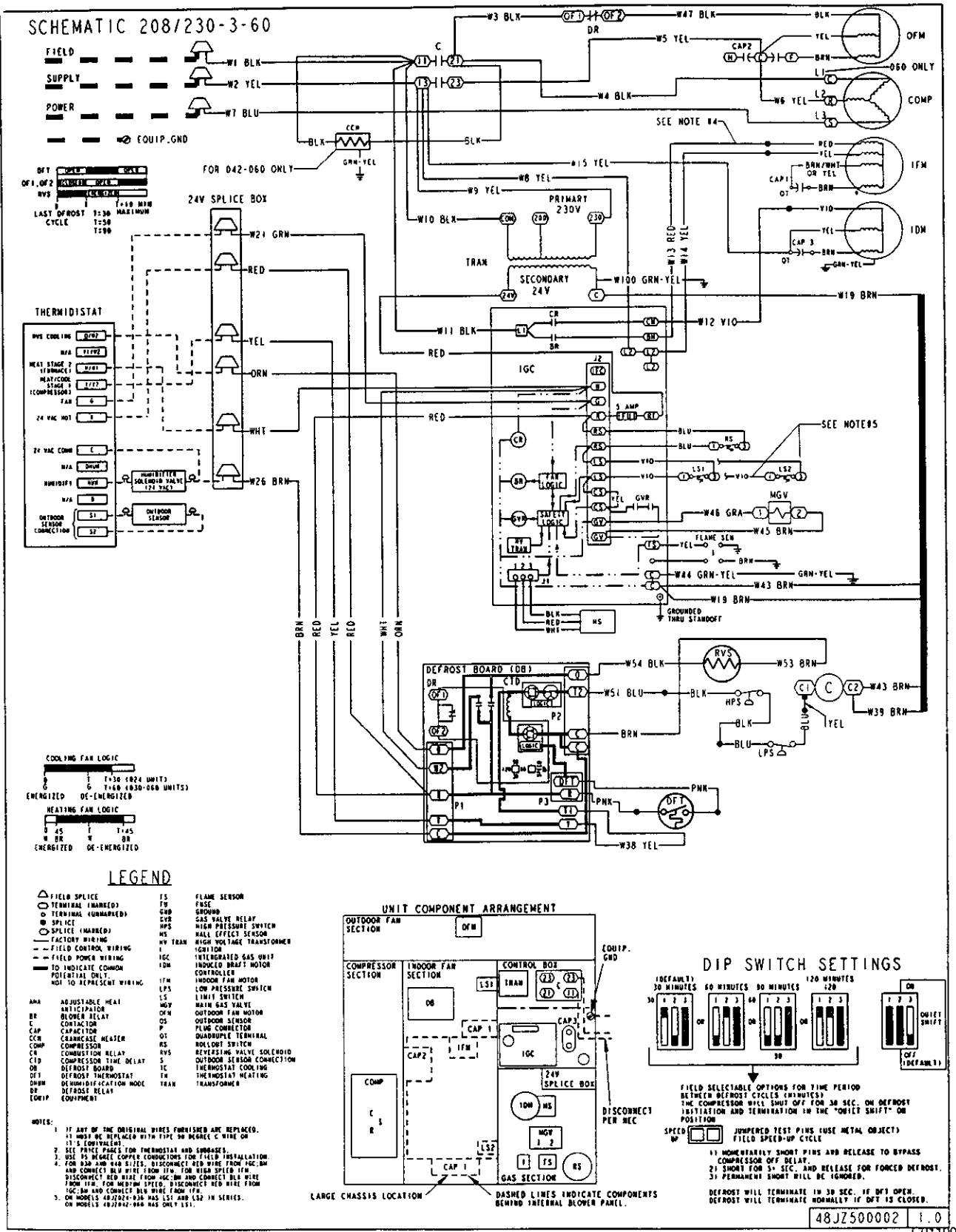

Fig. 16—208/230-3-60 Wiring Diagram, Units 48JZ

- When the gas supply being used has a different heating value or specific gravity, refer to national and local codes, or contact your distributor to determine the required orifice size.

SCHEMATIC 208/230-1-60

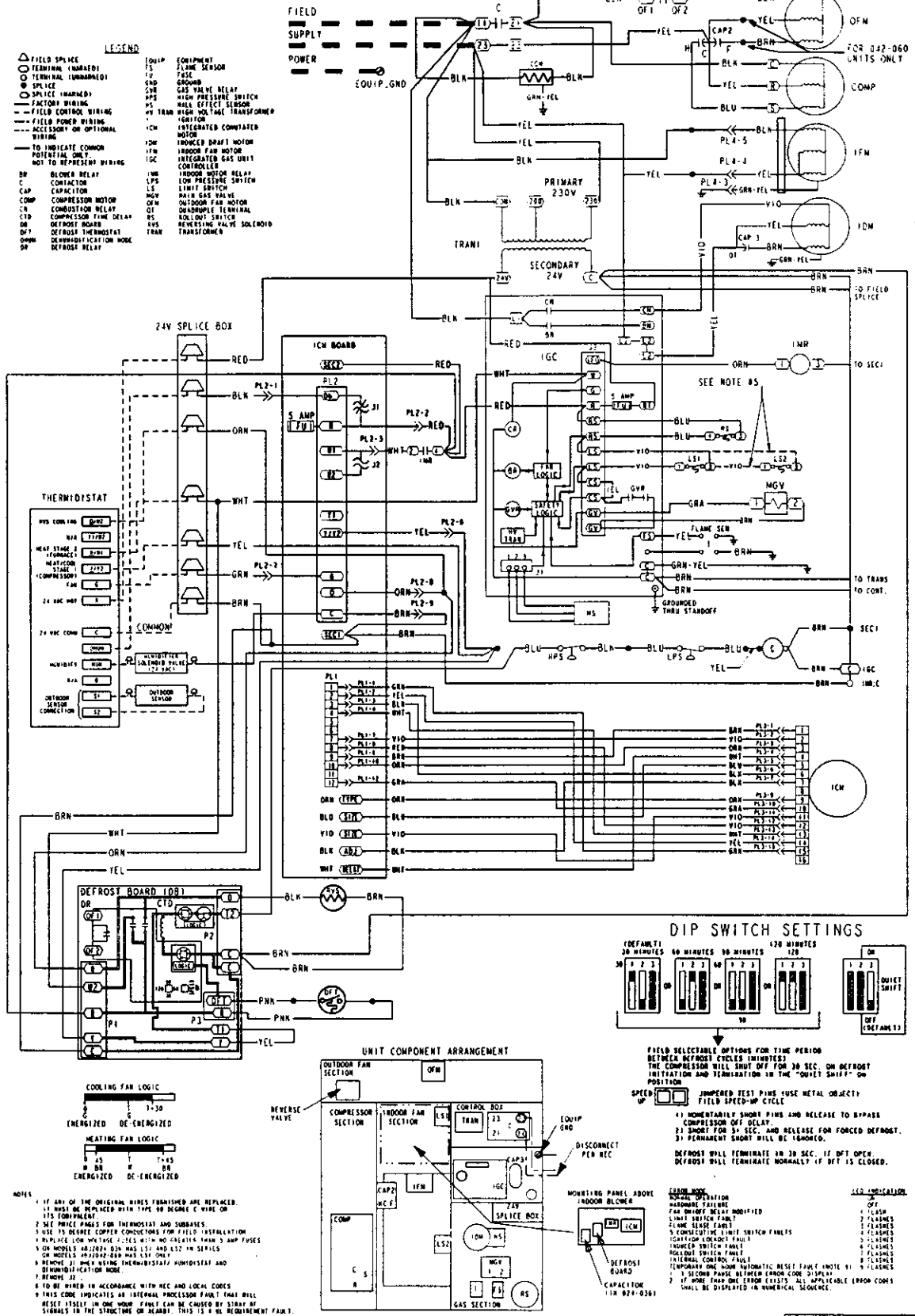

Fig. 17—208/230-1-60 ICM FIOP Wiring Diagram, Unit 48JZ

Table 5—Heating Inputs

| HEATING INPUT (BTUH)* | NUMBER OF ORIFICES | GAS SUPPLY PRESSURE (IN. WG) | | | | MANIFOLD PRESSURE (IN. WG) | |
|-----------------------|--------------------|------------------------------|------|----------|------|----------------------------|----------|
| | | Natural | | Propane† | | Natural | Propane† |
| | | Min | Max | Min | Max | | |
| 40,000 | 2 | 4.0 | 13.0 | 4.0 | 13.0 | 3.5 | 3.5 |
| 60,000 | 2 | 4.0 | 13.0 | 4.0 | 13.0 | 3.5 | 3.5 |
| 90,000 | 3 | 4.0 | 13.0 | 4.0 | 13.0 | 3.5 | 3.4 |
| 115,000 | 3 | 4.0 | 13.0 | 4.0 | 13.0 | 3.5 | 3.7 |
| 130,000 | 3 | 4.0 | 13.0 | 4.0 | 13.0 | 3.5 | 3.5 |

† When a unit is converted to propane, different size orifices must be used. See separate, natural-to-propane conversion kit instructions.
 * Based on altitudes from sea level to 2000 ft above sea level. For altitudes above 2000 ft, reduce input rating 4 percent for each 1000 ft above sea level. In Canada, from 2000 ft above sea level to 4500 ft above sea level, de-rate the unit 10 percent.

⚠ CAUTION

These units are designed to consume the rated gas inputs using the fixed orifices at specified manifold pressures as shown in Table 5. **DO NOT RE-DRILL THE ORIFICES UNDER ANY CIRCUMSTANCES.**

ADJUST GAS INPUT

The gas input to the unit is determined by measuring the gas flow at the meter or by measuring the manifold pressure. Measuring the gas flow at the meter is recommended for natural gas units. The manifold pressure must be measured to determine the input of propane gas units.

Measure Gas Flow (Natural Gas Units)

Minor adjustment to the gas flow can be made by changing the manifold pressure. The manifold pressure must be maintained between 3.4 and 3.6 in. wg. If larger adjustments are required, change main burner orifices following the recommendations of national and local codes.

NOTE: All other appliances that use the same meter must be turned off when gas flow is measured at the meter.

Proceed as follows:

1. Turn off gas supply to unit.
2. Remove pipe plug on manifold (See Fig. 13) and connect manometer. Turn on gas supply to unit.
3. Initiate a call for Gas Heating.
4. Record number of seconds for gas meter test dial to make one revolution.
5. Divide number of seconds in Step 3 into 3600 (number of seconds in one hour).
6. Multiply result of Step 4 by the number of cu ft shown for one revolution of test dial to obtain cu ft of gas flow per hour.
7. Multiply result of Step 5 by Btu heating value of gas to obtain total measured input in Btuh. Compare this value with heating input shown in Table 5. (Consult the local gas supplier if the heating value of gas is not known.)

EXAMPLE: Assume that the size of test dial is 1 cu ft, one revolution takes 32 sec., and the heating value of the gas is 1050 Btu/ft³. Proceed as follows:

1. 32 sec. to complete one revolution.
2. $3600 \div 32 = 112.5$.
3. $112.5 \times 1 = 112.5$ ft³ of gas flow/hr.
4. $112.5 \times 1050 = 118,125$ Btuh input.

If the desired gas input is 115,000 Btuh, only a minor change in the manifold pressure is required.

Observe manifold pressure and proceed as follows to adjust gas input:

1. Remove cover screw over regulator adjustment screw on gas valve.
2. Turn regulator adjustment screw clockwise to increase gas input, or turn regulator adjustment screw counterclockwise to decrease input. Manifold pressure must be between 3.4 and 3.6 in. wg. Unsafe operation of the unit may result if manifold pressure is outside this range. Personal injury or unit damage may result.

⚠ WARNING

Unsafe operation of the unit may result if manifold pressure is outside this range. Serious injury, death or unit damage may result.

3. Replace cover screw cap on gas valve.
4. Turn off gas supply to unit. Remove manometer from pressure tap and replace pipe plug on gas valve. Turn on gas to unit and check for leaks.

Measure Manifold Pressure (Propane Units)

The main burner orifices on a propane gas unit are sized for the unit rated input when the manifold pressure reading matches the level specified in Table 5.

Proceed as follows to adjust gas input on a propane gas unit:

1. Turn off gas to unit.
2. Remove pipe plug on manifold and connect manometer (See Fig. 13).
3. Turn on gas to unit.
4. Initiate a call for Gas Heating.
5. Remove cover screw over regulator adjustment screw on gas valve.
6. Adjust regulator adjustment screw to the correct manifold pressure, as specified in Table 5. Turn adjusting screw clockwise to increase manifold pressure, or turn adjusting screw counterclockwise to decrease manifold pressure.
7. Replace cover screw.
8. Turn off gas to unit. Remove manometer from pressure tap. Replace pipe plug on gas valve, then turn on gas to unit. Check for leaks.

CHECK BURNER FLAME

With burner access panel removed, observe the unit heating operation. Watch the burner flames to see if they are light blue and soft in appearance, and that the flames are approximately the same for each burner. Propane will have blue flame with yellow tips (See Fig. 14). Refer to the *Maintenance* section for information on burner removal.

Table 6—Air Delivery (CFM) at Indicated Temperature Rise and Rated Heating Input

| HEATING INPUT (BTUH) | TEMPERATURE RISE °F | | | | | | | | | | |
|----------------------|---------------------|------|------|------|------|------|------|------|------|------|------|
| | 20 | 25 | 30 | 35 | 40 | 45 | 50 | 55 | 60 | 65 | 70 |
| 40,000 | 1500 | 1200 | 1000 | 857 | 750 | 667 | 600 | 545 | 500 | — | — |
| 60,000 | 2250 | 1800 | 1500 | 1286 | 1125 | 1000 | 900 | 818 | 750 | 692 | — |
| 90,000 | — | — | 2250 | 1929 | 1688 | 1500 | 1350 | 1227 | 1125 | 1038 | 964 |
| 115,000 | — | — | — | 2464 | 2156 | 1917 | 1725 | 1568 | 1438 | 1327 | 1232 |
| 130,000 | — | — | — | 2786 | 2438 | 2167 | 1950 | 1773 | 1625 | 1500 | — |

NOTE: Dashed areas do not fall within the approved temperature rise range of the unit.

AIRFLOW AND TEMPERATURE RISE

The heating section for each size unit is designed and approved for heating operation within the temperature-rise range stamped on the unit rating plate.

Table 6 shows the approved temperature rise range for each heating input, and the air delivery CFM at various temperature rises. The heating operation airflow must produce a temperature rise that falls within the approved range.

Table 6 shows the approved temperature rise range for each heating input, and the air delivery CFM at various temperature rises. The heating operation airflow must produce a temperature rise that falls within the approved range.

Refer to *Indoor Airflow and Airflow Adjustments* section to adjust heating airflow when required.

HEATING SEQUENCE OF OPERATION-HEAT PUMP

Heat Pump Heating—Sequence of Operation: Outdoor temperature *above* balance point setpoint of Thermidistat™ (option 11).

(See Fig. 15, 16 & 17)

On a call for heating, terminals “Y” and “G” of the Thermidistat™ or Dual Fuel thermostat are energized. The “Y” signal is sent to the Defrost Board (DB) terminal “Y”. The DB has a built in five minute *anti-short cycle* timer which will not allow the compressor to restart before the time delay has expired. “T2” energizes the compressor contactor via the High Pressure Switch (HPS) and Low Pressure Switch (LPS). The compressor and outdoor fan start. Thermidistat™ “G” energizes the Integrated Gas Control (IGC) terminal “G”. The blower motor is energized through the “BM” and “L2” terminals of the IGC.

When the Thermidistat™ removes the “Y” and “G” calls, the compressor contactor and outdoor fan and evaporator motor are de-energized.

HEATING SEQUENCE OF OPERATION-GAS HEAT

Gas Heating—Sequence of Operation: Outdoor temperature *below* balance point setpoint of Thermidistat™ (option 11).

(See Fig. 15, 16 & 17)

On a call for heating, terminal “W” of the Thermidistat™ or Dual Fuel thermostat is energized, starting the induced-draft motor. When the hall-effect sensor on the induced-draft motor senses that it has reached the required speed, the burner sequence begins. This function is performed by the integrated gas control (IGC). The indoor-fan motor is energized 45 sec. after flame is established. When the thermostat is satisfied and “W” is de-energized, the burners stop firing and the indoor-fan motor shuts off after a 45-sec. time-off delay.

An LED (light-emitting diode) indicator is provided on the control board to monitor operation. The control board is located by removing the burner access panel. During normal operation, the LED is continuously on. (See Table 7 for error codes.)

Table 7—LED Indications

| ERROR CODE | LED INDICATION |
|---|----------------|
| Normal Operation | On |
| Hardware Failure | Off |
| Fan On/Off Delay Modified | 1 Flash |
| Limit Switch Fault | 2 Flashes |
| Flame Sense Fault | 3 Flashes |
| Four Consecutive Limit Switch Faults | 4 Flashes |
| Ignition Lockout Fault | 5 Flashes |
| Induced-Draft Motor Fault | 6 Flashes |
| Rollout Switch Fault | 7 Flashes |
| Internal Control Fault | 8 Flashes |
| Temporary one hour automatic reset fault (See note 2) | 9 Flashes |

NOTES:

1.
 - A. There is a 3-sec. pause between error code displays.
 - B. If more than one error code exists, all applicable error codes will be displayed in numerical sequence
 - C. This chart is on the wiring diagram located inside the burner access panel.
2.
 - A. This code indicates an internal processor fault that will reset itself in one hour. Fault can be caused by stray RF signals in the structure or nearby. This is a UL requirement.
 - B. When W1 is energized the burners will remain on for a minimum of 60 seconds.

LIMIT SWITCHES

Normally closed limit switch (LS)— The limit switch is normally closed and opens on sensing excessive temperature rise in the heat exchanger compartment. Should the leaving-air temperature rise above the maximum allowable temperature, the limit switch opens. When the limit switch opens the IGC control circuit instantly opens the gas valve circuit and stops gas flow to the burners. The blower motor continues to run until LS resets.

When the air temperature at the limit switch drops to the low-temperature setting of the limit switch, the switch closes allows the ignition cycle to restart. The electric-spark ignition system cycles and the unit returns to normal heating operation.

AUXILIARY LIMIT SWITCH (ROLLOUT)

The function of the switch is to close the main gas valve in the event of flame rollout. The switch is located above the main burners. When the temperature at the auxiliary switch reaches the maximum allowable temperature and opens, the IGC circuit opens, opening the gas valve circuit and stopping gas flow to the burners. The indoor fan motor (IFM) and induced draft motor continue to run until switch is reset. The IGC LED will display FAULT CODE 7.

Step 3—START-UP COOLING AND MAKE ADJUSTMENTS

⚠ CAUTION

Complete the required procedures given in the *Pre-Start-Up* section before starting the unit.

Do not jumper any safety devices when operating the unit. Do not operate the compressor in cooling mode when the outdoor temperature is below 40°F (unless accessory low-ambient kit is installed).

Do not rapid-cycle the compressor. Allow 5 minutes between "on" cycles to prevent compressor damage.

COOLING SEQUENCE OF OPERATION

With the room thermostat SYSTEM switch in the COOL position and the FAN switch in the AUTO. position, the cooling sequence of operation is as follows:

1. When the room temperature rises to a point that is slightly above the cooling control setting of the thermostat, the thermostat completes circuit between thermostat terminal "R" to terminals "Y", "G" and "O". These completed circuits through the thermostat:
2. "O" terminal energizes Reversing Valve (RV) through Defrost Board (DB). *Note:* The RV remains energized while the Thermidstat™ cooling mode is selected.
3. "Y" terminal energizes DB "Y". After 5 minute time delay of DB terminals "T1" & "T2" has expired, if LPS and HPS safety switches are closed. Compressor contactor is energized starting the compressor and outdoor fan motor.
4. "G" terminal energizes "BM" terminal of Integrated Gas Control (IGC) and the indoor motor starts.

NOTE: Once the compressor has started and then stopped, it should not be started again until 5 minutes have elapsed. The cooling cycle remains "on" until the room temperature drops to a point that is slightly below the cooling control setting. The thermostat opens the circuit between thermostat terminal R to terminals Y, O and G. These open circuits de-energize contactor coil C and BM of the IGC. The outdoor and compressor motors stop. After a 30-sec. delay, the blower motor stops. The unit is in a "standby" condition, waiting for the next "call for cooling" from the room thermostat.

CHECKING COOLING CONTROL OPERATION (NON-ICM UNITS)

Start and check the unit for proper cooling control operation as follows:

1. Place room thermostat SYSTEM switch in OFF position. Observe that blower motor starts when FAN switch is placed in ON position and shuts down when FAN switch is placed in AUTO. position.
2. Place SYSTEM switch in COOL position and FAN switch in AUTO. position. Set cooling control below room temperature. Observe that compressor, outdoor fan, and indoor blower motors start. Observe that cooling cycle shuts down when control setting is satisfied. The indoor fan will continue to run for 30 sec.
3. When using an auto-changeover room thermostat, place both SYSTEM and FAN switches in AUTO. positions. Observe that unit operates in Heating mode when temperature control is set to "call for heating" (above room temperature) and operates in Cooling mode when temperature control is set to "call for cooling" (below room temperature).

COMPRESSOR ROTATION

On 3-phase units with scroll compressors, it is important to be certain compressor is rotation in the proper direction. To determine whether or not compressor is rotating in the proper direction:

1. Connect service gages to suction and discharge pressure fittings.
2. Energize the compressor.
3. The suction pressure should drop and the discharge pressure should rise, as is normal on any start-up.

If the suction pressure does not drop and the discharge pressure does not rise to normal levels:

1. Reverse any two of the unit power leads.
2. Reapply power to the compressor.

The suction and discharge pressure levels should now move to their normal start-up levels.

NOTE: When the compressor is rotating in the wrong direction, the unit makes an elevated level of noise and does not provide cooling.

CHECKING AND ADJUSTING REFRIGERANT CHARGE

The refrigerant system is fully charged with R-410A refrigerant, tested, and factory-sealed.

NOTE: Adjustment of the refrigerant charge is not required unless the unit is suspected of not having the proper R-410A charge. The charging label and the tables shown refer to system temperatures and pressures in cooling mode only.

An accurate superheat, thermocouple- or thermistor-type thermometer, a sling psychrometer, and a gauge manifold are required when using the superheat charging method for evaluating the unit charge. *Do not use mercury or small dial-type thermometers because they are not adequate for this type of measurement.*

⚠ CAUTION

When evaluating the refrigerant charge, an indicated adjustment to the specified factory charge must always be very minimal. If a substantial adjustment is indicated, an abnormal condition exists somewhere in the cooling system, such as insufficient airflow across either coil or both coils.

Refrigerant Charge— Amount of refrigerant charge is listed on unit nameplate (also refer to Table 1). Refer to Corporate GTAC 2-5 Charging, Recovery, Recycling, and Reclamation training manual and the following procedures.

NOTE: Unit panels must be in place when unit is operating during charging procedure.

1. *No Charge—* Use standard evacuating techniques. After evacuating system, weigh in the specified amount of refrigerant (Refer to Table 1).
2. *Low-Charge Cooling—* Using Cooling Charging Charts (Fig 20–25), vary refrigerant until the conditions of the appropriate chart are met. These charging charts are different from type normally used. Charts are based on charging the units to the correct superheat for various operating conditions. Accurate pressure gauge and temperature sensing device are required. Connect the pressure gauge to the service port on the suction line. Mount the temperature sensing device on the suction line and insulate it so that outdoor ambient temperature does not affect the reading. Indoor air (CFM) must be within the normal operating range of the unit.
3. *Using Cooling Charging Charts—* Compare outdoor-air temperature (°F db) and the suction line pressure (psig) and temperature with corresponding charging chart (See Fig. 20–25).

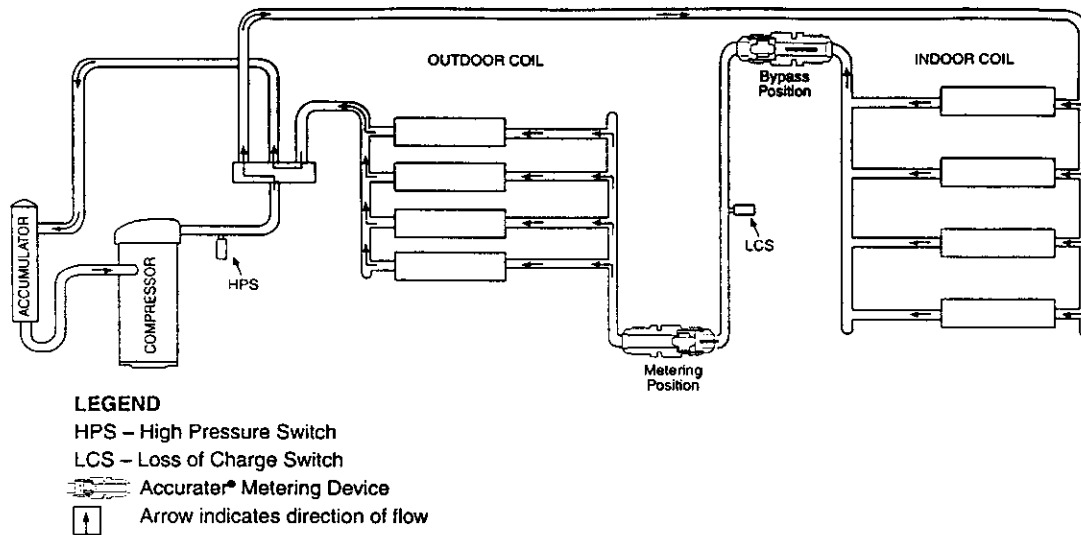

C00095

Fig. 18—Typical Heat Pump Operation, Heating Mode

EXAMPLE: (Fig. 20)

Outdoor Temperature.....85 F

Suction Pressure.....145 psig

Suction Temperature should be...70 F

(Suction Temperature may vary $\pm 3^{\circ}\text{F}$)

- Using a tolerance of $\pm 3^{\circ}\text{F}$, add refrigerant if actual temperature is more than 3°F higher than proper suction-tube temperature, or remove refrigerant if actual temperature is more than 3°F lower than required suction-tube temperature. Recheck the readings as charge is adjusted.

NOTE: If the problem causing the inaccurate readings is a refrigerant leak, refer to the *Check for Refrigerant Leaks* section.

INDOOR AIRFLOW AND AIRFLOW ADJUSTMENTS

⚠ CAUTION

For cooling operation, the recommended airflow is 350 to 450 cfm for each 12,000 Btuh of rated cooling capacity. For heating operation, the airflow must produce a temperature rise that falls within the range stamped on the unit rating plate.

Table 6 shows the temperature rise at various airflow rates. Table 10 shows both heating and cooling airflows at various external static pressures. Refer to these tables to determine the airflow for the system being installed.

NOTE: Be sure that all supply- and return-air grilles are open, free from obstructions, and adjusted properly.

⚠ WARNING

Before changing blower speed, shut off gas supply. Then disconnect electrical power to the unit. Electrical shock or explosion can cause serious injury or death.

Airflow can be changed by changing the lead connections of the blower motor.

All 48JZ units are factory wired for low speed and may need to be wired for medium or high speed in the field.

For 208/230V

For color coding on the 208/230V motor leads, see Table 8.

To change the speed of the blower motor, remove the fan motor speed leg lead from the blower relay (BM on the IGC). This wire

Table 8—Color Coding for 208/230-V Motor Leads

| 3-SPEED | 2-SPEED |
|---------------------|--------------------|
| black = high speed | black = high speed |
| blue = medium speed | — |
| red = low speed | red = low speed |

is attached to terminal BM for single- and 3-phase units. To change the speed, remove and replace with lead for desired blower motor speed. Insulate the removed lead to avoid contact with chassis parts.

MAINTENANCE

To ensure continuing high performance and to minimize the possibility of premature equipment failure, periodic maintenance must be performed on this equipment. This combination heating/cooling unit should be inspected at least once each year by a qualified service person. To troubleshoot cooling or heating components of units, refer to Tables 11, 12 and 13.

NOTE: Consult your local dealer about the availability of a maintenance contract.

⚠ WARNING

The ability to properly perform maintenance on this equipment requires certain expertise, mechanical skills, tools, and equipment. If you do not possess these, do not attempt to perform any maintenance on this equipment other than those procedures recommended in the User's Manual. FAILURE TO HEED THIS WARNING COULD RESULT IN SERIOUS INJURY OR DEATH AND POSSIBLE DAMAGE TO THIS EQUIPMENT.

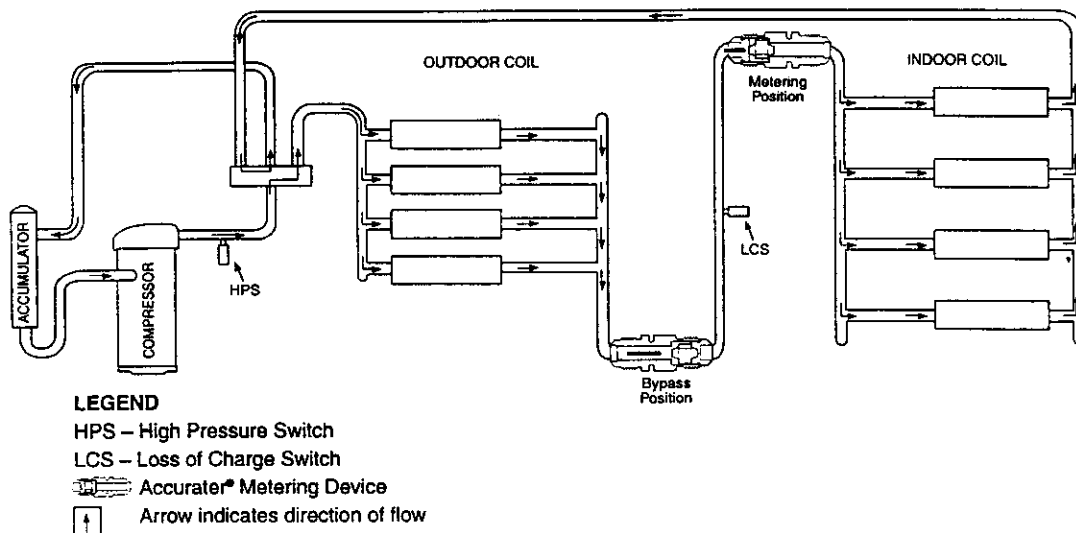

C00096

Fig. 19—Typical Heat Pump Operation, Cooling Mode

Table 9—Filter Pressure Drop (In. wg)

| FILTER SIZE | CFM | | | | | | | | | | | | | | | | | | | |
|-------------|------|------|------|------|------|------|------|------|------|------|------|------|------|------|------|------|------|------|------|---|
| | 500 | 600 | 700 | 800 | 900 | 1000 | 1100 | 1200 | 1300 | 1400 | 1500 | 1600 | 1700 | 1800 | 1900 | 2000 | 2100 | 2200 | 2300 | |
| 20 X 20 X 1 | 0.05 | 0.07 | 0.08 | 0.10 | 0.12 | 0.13 | 0.14 | 0.15 | — | — | — | — | — | — | — | — | — | — | — | — |
| 20 X 24 X 1 | — | — | — | — | 0.09 | 0.10 | 0.11 | 0.13 | 0.14 | 0.15 | 0.16 | — | — | — | — | — | — | — | — | — |
| 24 X 30 X 1 | — | — | — | — | — | — | — | 0.07 | 0.08 | 0.09 | 0.10 | 0.11 | 0.12 | 0.13 | 0.14 | 0.15 | 0.16 | 0.17 | 0.18 | — |

⚠ WARNING

Failure to follow these warnings could result in serious injury or death:

1. First, turn off gas supply to the unit. *Then* turn off electrical power and install lock-out tag before performing any maintenance or service on the unit.
2. Use extreme caution when removing panels and parts. As with any mechanical equipment, personal injury can result from sharp edges, etc.
3. Never place anything combustible either on, or in contact with, the unit.
4. Should overheating occur or the gas supply fail to shut off, turn off external main manual gas valve to the unit. *Then* shut off electrical supply.

⚠ CAUTION

Errors made when reconnecting wires may cause improper and dangerous operation. Label all wires prior to disconnection when servicing.

⚠ WARNING

Before cleaning the blower motor and wheel, turn off gas supply. *Then* turn off and tag electrical power to the unit. Failure to adhere to this warning could cause serious injury or death.

The minimum maintenance requirements for this equipment are as follows:

1. Inspect air filter(s) each month. Clean or replace when necessary. Certain geographical locations may require more frequent inspections.

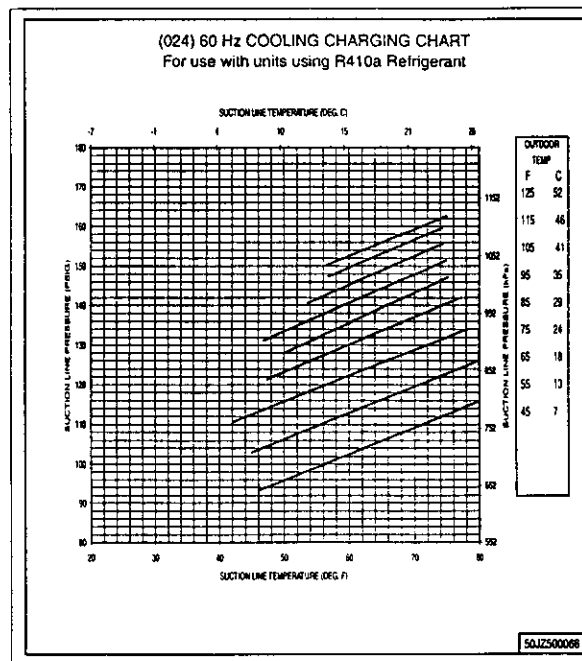

C00082

Fig. 20—Cooling Charging Chart, 48JZ024 Units

2. Inspect indoor coil, outdoor coil, drain pan, and condensate drain each cooling season for cleanliness. Clean when necessary.
3. Inspect blower motor and wheel for cleanliness at the beginning of each heating and cooling season. Clean when necessary. For *first* heating and cooling season, inspect blower

**Table 10—Wet Coil Air Delivery* – Horizontal and Downflow Discharge –
Unit 48JZ024-060 (Deduct 10 percent for 208 Volts)**

| | | 230 VOLT | | | | | | | | | | | |
|------|-------------|----------|-----------------------------------|------|------|------|------|------|------|------|------|------|------|
| Unit | Motor Speed | | External Static Pressure (in. wg) | | | | | | | | | | |
| | | | 0.0 | 0.1 | 0.2 | 0.3 | 0.4 | 0.5 | 0.6 | 0.7 | 0.8 | 0.9 | 1.0 |
| 024 | Low | Watts | 279 | 282 | 280 | 277 | 276 | — | — | — | — | — | — |
| | | Cfm | 882 | 801 | 738 | 674 | 604 | — | — | — | — | — | — |
| | Med | Watts | — | — | — | 373 | 367 | 361 | 356 | 351 | — | — | — |
| | | Cfm | — | — | — | 936 | 868 | 797 | 719 | 626 | — | — | — |
| | High | Watts | — | — | — | — | — | 463 | 452 | 439 | 428 | — | — |
| | | Cfm | — | — | — | — | — | 956 | 878 | 794 | 702 | — | — |
| 030 | Low | Watts | 243 | 244 | 242 | — | — | — | — | — | — | — | |
| | | Cfm | 885 | 842 | 786 | — | — | — | — | — | — | — | |
| | Med | Watts | 353 | 339 | 333 | 330 | 326 | 320 | — | — | — | — | |
| | | Cfm | 1195 | 1134 | 1070 | 997 | 911 | 818 | — | — | — | — | |
| | High | Watts | — | — | — | 443 | 436 | 426 | 416 | 406 | 397 | — | — |
| | | Cfm | — | — | — | 1230 | 1145 | 1061 | 977 | 888 | 786 | — | — |
| 036 | Low | Watts | 490 | 463 | 446 | 432 | 418 | 403 | 389 | 378 | — | — | |
| | | Cfm | 1431 | 1398 | 1347 | 1281 | 1205 | 1118 | 1024 | 921 | — | — | |
| | Med | Watts | — | 513 | 501 | 488 | 474 | 459 | 443 | 428 | — | — | |
| | | Cfm | — | 1491 | 1426 | 1351 | 1267 | 1175 | 1077 | 976 | — | — | |
| | High | Watts | — | — | 645 | 636 | 627 | 616 | 605 | 593 | 583 | — | — |
| | | Cfm | — | — | 1484 | 1410 | 1330 | 1243 | 1147 | 1044 | 936 | — | — |
| 042 | Low | Watts | 634 | 618 | 608 | 598 | 583 | 562 | 534 | 502 | 473 | 454 | 457 |
| | | Cfm | 1669 | 1599 | 1545 | 1498 | 1448 | 1391 | 1326 | 1257 | 1189 | 1132 | 1101 |
| | Med | Watts | — | — | — | 733 | 704 | 672 | 638 | 604 | 574 | 550 | 536 |
| | | Cfm | — | — | — | 1746 | 1688 | 1630 | 1566 | 1492 | 1399 | 1279 | 1120 |
| | High | Watts | — | — | — | — | — | — | 797 | 773 | 751 | 727 | 696 |
| | | Cfm | — | — | — | — | — | — | 1727 | 1632 | 1537 | 1423 | 1308 |
| 048 | Low | Watts | 591 | 578 | 573 | 568 | 559 | 544 | 524 | 500 | — | — | |
| | | Cfm | 1554 | 1523 | 1496 | 1467 | 1432 | 1387 | 1332 | 1269 | — | — | |
| | Med | Watts | 755 | 737 | 719 | 699 | 678 | 653 | 627 | 602 | 579 | 562 | 556 |
| | | Cfm | 1834 | 1802 | 1758 | 1706 | 1648 | 1585 | 1520 | 1455 | 1392 | 1332 | 1276 |
| | High | Watts | — | — | — | 890 | 858 | 828 | 801 | 777 | 756 | 734 | 709 |
| | | Cfm | — | — | — | 1943 | 1870 | 1793 | 1711 | 1624 | 1531 | 1433 | 1329 |
| 060 | Low | Watts | 589 | 576 | 569 | 566 | 559 | 541 | 499 | — | — | — | |
| | | Cfm | 1946 | 1891 | 1836 | 1779 | 1718 | 1651 | 1577 | — | — | — | |
| | Med | Watts | 750 | 733 | 715 | 695 | 673 | 648 | 623 | 598 | 577 | — | |
| | | Cfm | 2189 | 2097 | 2021 | 1952 | 1883 | 1809 | 1727 | 1635 | 1530 | — | |
| | High | Watts | — | 879 | 850 | 821 | 795 | 772 | 750 | 728 | 701 | — | |
| | | Cfm | — | 2337 | 2159 | 2050 | 1974 | 1905 | 1824 | 1722 | 1597 | — | |

* Air delivery values are without air filter.

NOTE: Deduct field-supplied air filter pressure drop to obtain external static pressure available for ducting.

wheel bi-monthly to determine proper cleaning frequency.

4. Check electrical connections for tightness and controls for proper operation each heating and cooling season. Service when necessary.
5. Check and inspect heating section before each heating season. Clean and adjust when necessary.
6. Check flue hood and remove any obstructions, if necessary.

AIR FILTER

⚠ CAUTION

Never operate the unit without a suitable air filter in the return-air duct system. Always replace the filter with the same dimensional size and type as originally installed. (See Table 1 for recommended filter sizes.)

Inspect air filter(s) at least once each month and replace (throwaway-type) or clean (cleanable-type) at least twice during each heating and cooling season or whenever the filter(s) becomes clogged with dust and/or lint.

INDOOR BLOWER AND MOTOR

NOTE: All motors are prelubricated. Do not attempt to lubricate these motors.

For longer life, operating economy, and continuing efficiency, clean accumulated dirt and grease from the blower wheel and motor annually.

⚠ WARNING

Before cleaning the blower motor and wheel, turn off gas supply. Then turn off and tag electrical power to the unit. Failure to adhere to this warning could cause serious injury or death.

Cleaning the Blower Motor and Wheel

1. Remove and disassemble blower assembly as follows:
 - a. Remove unit access and internal blower panels.
 - b. Disconnect motor lead from blower relay (BR). Disconnect yellow lead from terminal L2 of the contactor.

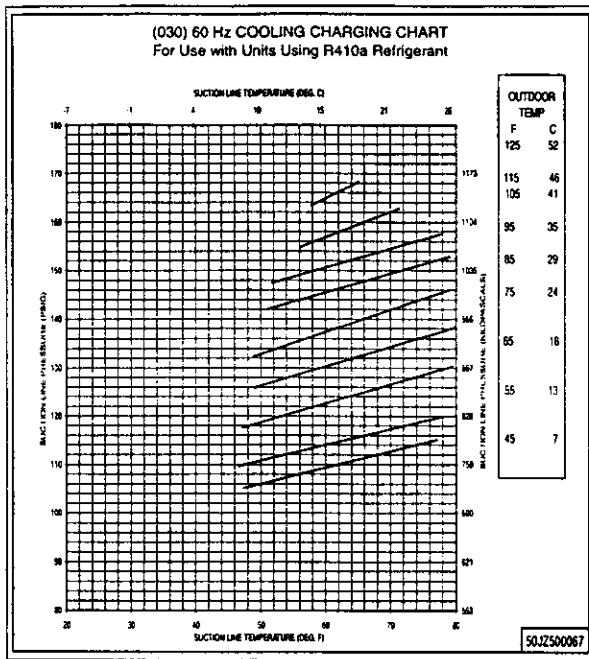

C00083

Fig. 21—Cooling Charging Chart, 48JZ030 Units

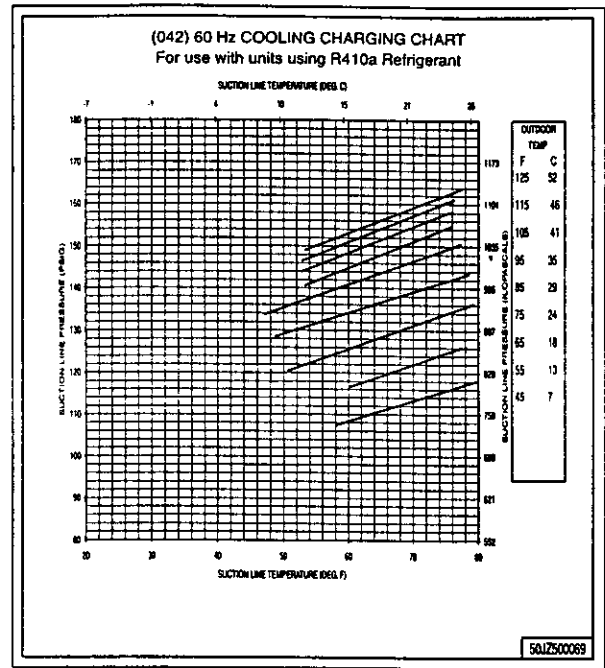

C00085

Fig. 23—Cooling Charging Chart, 48JZ042 Units

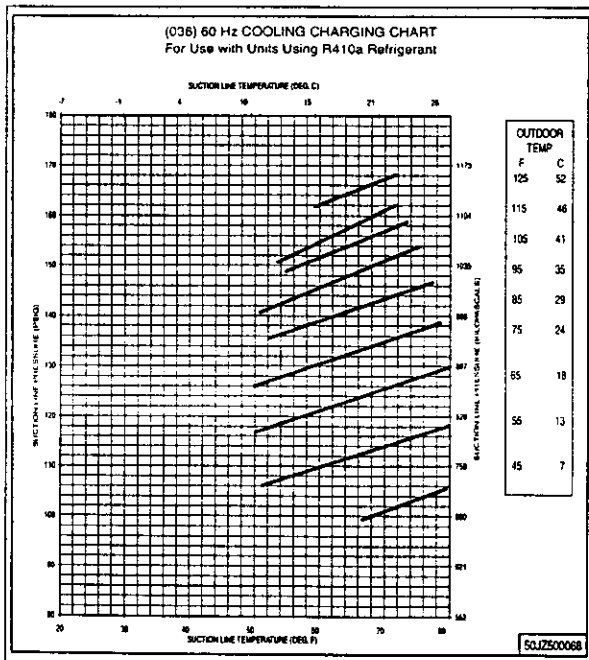

C00084

Fig. 22—Cooling Charging Chart, 48JZ036 Units

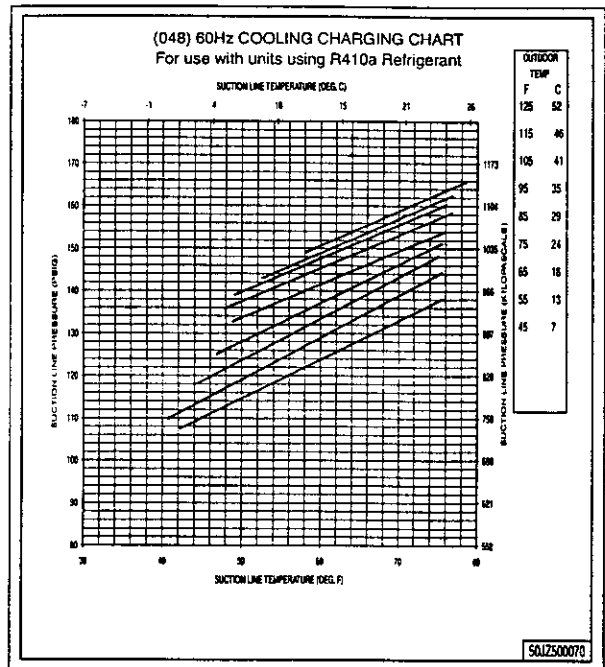

C00086

Fig. 24—Cooling Charging Chart, 48JZ048 Units

- c. On *all* units, remove blower assembly from unit. Remove screws securing blower to blower partition and slide assembly out. Be careful not to tear insulation in blower compartment.
 - d. Ensure proper reassembly by marking blower wheel and motor in relation to blower housing before disassembly.
 - e. Loosen setscrew(s) that secures wheel to motor shaft. Remove screws that secure motor mount brackets to housing, and slide motor and motor mount out of housing.
2. Remove and clean blower wheel as follows:

- a. Ensure proper reassembly by marking wheel orientation.
- b. Lift wheel from housing. When handling and/or cleaning blower wheel, be sure not to disturb balance weights (clips) on blower wheel vanes.
- c. Remove caked-on dirt from wheel and housing with a brush. Remove lint and/or dirt accumulations from wheel and housing with vacuum cleaner, using soft brush attachment. Remove grease and oil with mild solvent.
- d. Reassemble wheel into housing.

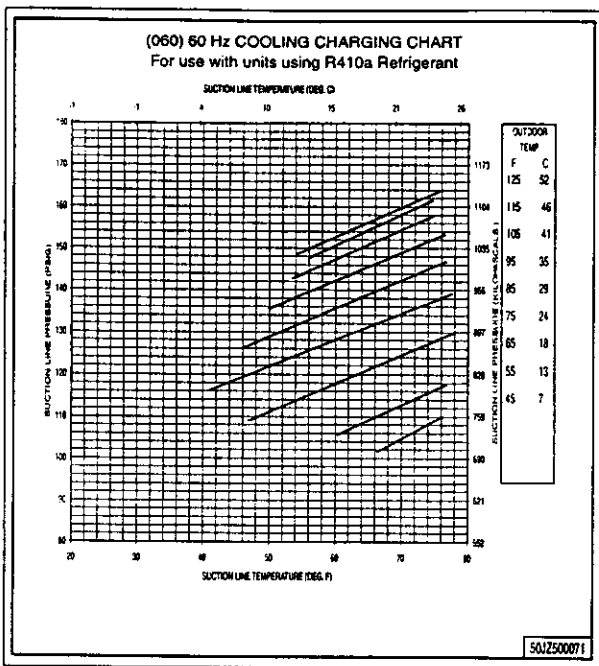

C00087

Fig. 25—Cooling Charging Chart, 48JZ060 Units

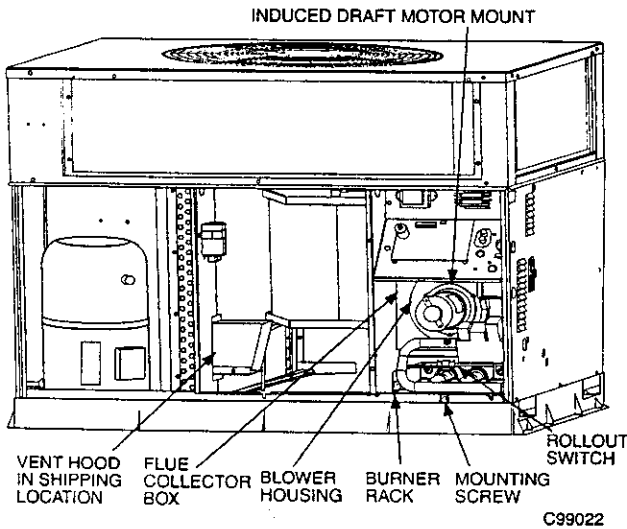

Fig. 26—Blower Housing and Flue Collector Box

- e. Reassemble motor into housing. Be sure setscrews are tightened on motor shaft flats and not on round part of shaft.
- f. Reinstall blower panel and unit access panel.
3. Restore electrical power to unit. Start unit and check for proper blower rotation and motor speeds during heating and cooling cycles.

FLUE GAS PASSAGEWAYS

To inspect the flue collector box and upper areas of the heat exchanger:

1. Remove the combustion blower wheel and motor assembly according to directions in the *Combustion-Air Blower* section.
2. Remove the 3 screws holding the blower housing to the flue collector box cover (See Fig. 28).

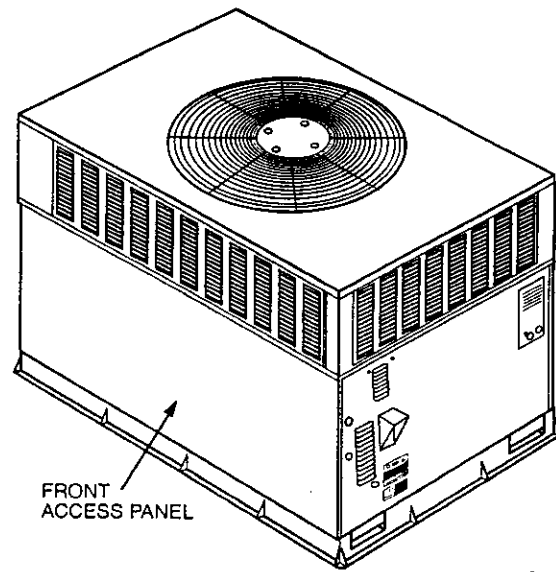

C99091

Fig. 27—Unit Access Panel

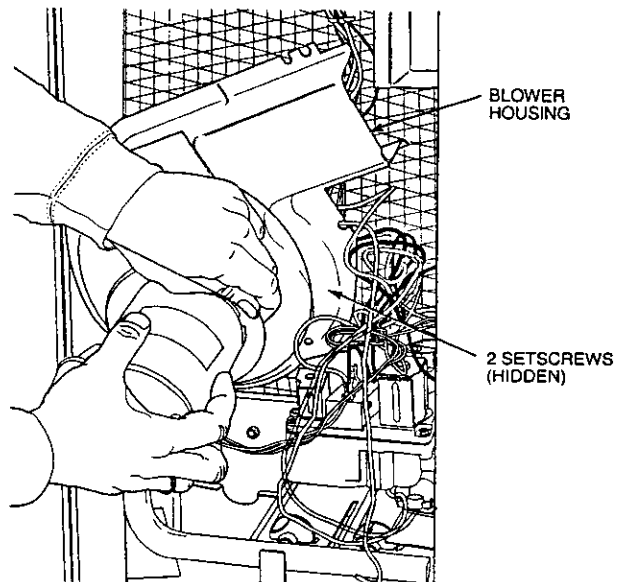

Fig. 28—Removal of Motor and Blower Wheel

3. Remove the 12 screws holding the flue collector box cover (See Fig. 26, 28 & 29) to the heat exchanger assembly. Inspect the heat exchangers.
4. Clean all surfaces, as required, using a wire brush.

COMBUSTION-AIR BLOWER

Clean periodically to assure proper airflow and heating efficiency. Inspect blower wheel every fall and periodically during the heating season. For the first heating season, inspect blower wheel bi-monthly to determine proper cleaning frequency.

To inspect blower wheel, remove draft hood assembly. Shine a flashlight into opening to inspect wheel. If cleaning is required, remove motor and wheel as follows:

1. Remove unit access panel (See Fig. 27).
2. Remove the 7 screws that attach induced-draft motor mounting plate to blower housing (See Fig. 26 & 28).

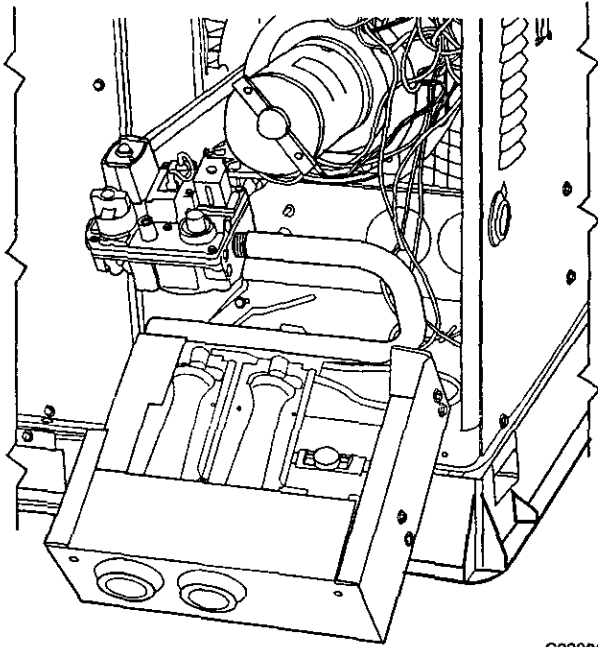

C99086

Fig. 29—Burner Rack Removed

3. Slide the motor and blower wheel assembly out of the blower housing (See Fig. 28). Clean the blower wheel. If additional cleaning is required, continue with Steps 4 and 5.
4. To remove blower, remove 2 setscrews.
5. To remove motor and cooling fan assembly, remove 4 screws that hold blower housing to mounting plate.
6. To reinstall, reverse the procedure outlined above.

LIMIT SWITCH

Remove unit access panel, then the blower door to gain access to the limit switch. The limit switch is located above the indoor blower housing.

BURNER IGNITION

Unit is equipped with a direct spark ignition 100 percent lockout system. Ignition module is located in the control box. Module contains a self-diagnostic LED. During servicing, refer to label diagram for LED interpretation.

If lockout occurs, unit may be reset by either momentarily interrupting power supply to unit or by turning selector switch to OFF position at the thermostat.

MAIN BURNERS

At the beginning of each heating season, inspect for deterioration or blockage due to corrosion or other causes. Observe the main burner flames and adjust, if necessary.

⚠ CAUTION

When servicing gas train, do not hit or plug orifice spuds.

Removal of Gas Train

To remove the gas train for servicing:

1. Shut off main gas valve.
2. Shut off power to unit.
3. Remove unit access panel (See Fig. 26).
4. Disconnect gas piping at unit gas valve.
5. Remove wires connected to gas valve. Mark each wire.

6. Remove ignitor and sensor wires at the ignitor module.
7. Remove the mounting screw that attaches the burner rack to the unit base (See Fig. 28).
8. Slide the burner rack out of the unit (See Fig. 26 and 29).
9. To reinstall, reverse the procedure outlined above.

OUTDOOR COIL, INDOOR COIL, AND CONDENSATE DRAIN

Inspect the Outdoor coil, Indoor coil, and condensate drain at least once each year.

The coils are easily cleaned when dry; therefore, inspect and clean the coils either before or after each cooling season. Remove all obstructions, including weeds and shrubs, that interfere with the airflow through the outdoor coil.

Straighten bent fins with a fin comb. If coated with dirt or lint, clean the coils with a vacuum cleaner, using the soft brush attachment. Be careful not to bend the fins. If coated with oil or grease, clean the coils with a mild detergent-and-water solution. Rinse coils with clear water, using a garden hose. Be careful not to splash water on motors, insulation, wiring, or air filter(s). For best results, spray outdoor coil fins from inside to outside the unit. On units with an outer and inner outdoor coil, be sure to clean between the coils. Be sure to flush all dirt and debris from the unit base.

Inspect the drain and condensate drain line when inspecting the coils. Clean the drain and condensate drain line by removing all foreign matter from the drain. Flush the drain and drain tube with clear water. Do not splash water on the insulation, motor, wiring, or air filter(s). If the drain tube is restricted, clear it with a "plumbers snake" or similar probe device. Ensure that the auxiliary drain port above the drain tube is also clear.

OUTDOOR FAN

⚠ CAUTION

Keep the outdoor fan free from all obstructions to ensure proper cooling operation. Never place articles on top of the unit. Damage to unit may result.

1. Remove 6 screws holding outdoor motor grille and motor to top cover.
2. Turn motor/grille assembly upside down on top cover to expose the fan blade.
3. Inspect the fan blades for cracks or bends.
4. If fan needs to be removed, loosen the setscrew and slide the fan off the motor shaft.
5. When replacing fan blade, position blade so the hub is 1/8 in. away from the motor end. (1/8 in. of motor shaft will be visible. See Fig. 12).
6. Ensure that setscrew engages the flat area on the motor shaft when tightening.
7. Replace grille.

ELECTRICAL CONTROLS AND WIRING

Inspect and check the electrical controls and wiring annually. *Be sure to turn off the gas supply, and then the electrical power to the unit.*

Remove access panel to locate all the electrical controls and wiring. Check all electrical connections for tightness. Tighten all screw connections. If any smoky or burned connections are noticed, disassemble the connection, clean all the parts, re-strip the wire end and reassemble the connection properly and securely.

After inspecting the electrical controls and wiring, replace the access panel. Start the unit, and observe at least one complete

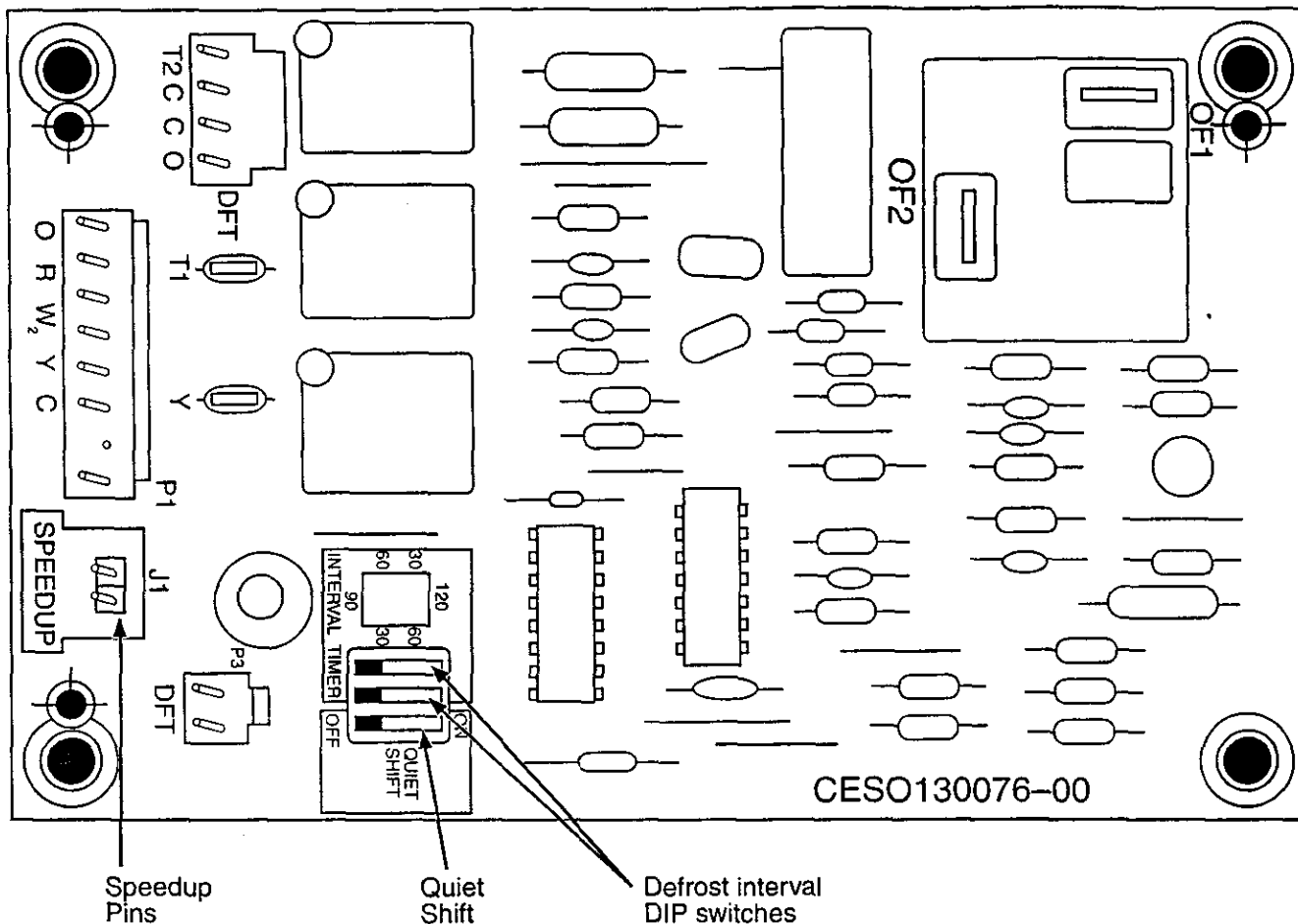

Fig. 30—Defrost Control Board

A99442

heating cycle and one complete cooling cycle to ensure proper operation. If discrepancies are observed in either or both operating cycles, or if a suspected malfunction has occurred, check each electrical component with the proper electrical instrumentation. Refer to the unit wiring label when making these checkouts.

NOTE: Refer to the heating and/or cooling sequence of operation in this publication as an aid in determining proper control operation

HEAT PUMP SYSTEM ITEMS

Defrost Control

QUIET SHIFT

Quiet Shift is a field-selectable defrost mode, which will eliminate occasional noise that could be heard at the start of defrost cycle and restarting of heating cycle. It is selected by placing DIP switch 3 (on defrost board) in ON position.

When Quiet Shift switch is placed in ON position, and a defrost is initiated, the following sequence of operation will occur. Reversing valve will energize, outdoor fan will turn off, compressor will turn off for 30 sec and then turn back on to complete defrost. At the start of heating after conclusion of defrost reversing valve will de-energize, compressor will turn off for another 30 sec, and the outdoor fan will stay off for 40 sec, before starting in the Heating mode.

Defrost

The defrost control is a time/temperature control which includes a

field-selectable time period (DIP switch 1 and 2 on the board) between defrost cycles of 30, 60, 90, or 120 minutes (factory set at 30 minutes).

To initiate a forced defrost, two options are available depending on the status of the defrost thermostat.

If defrost thermostat is closed, speedup pins (J1) must be shorted by placing a flat head screw driver in between for 5 sec and releasing, to observe a complete defrost cycle. When the Quiet Shift switch is selected, compressor will be turned off for two 30 sec intervals during this complete defrost cycle, as explained previously. When Quiet Shift switch is in factory default OFF position, a normal and complete defrost cycle will be observed.

If defrost thermostat is in open position, and speedup pins are shorted (with a flat head screw driver) for 5 sec and released, a short defrost cycle will be observed (actual length is dependent upon the selected Quiet Shift position). When Quiet Shift switch is in ON position, the length of defrost is 1 minute (30 sec compressor off period followed by 30 sec of defrost with compressor operation). On return to heating operation, compressor will again turn off for an additional 30 sec and the outdoor fan for 40 sec. When the Quiet Shift is in OFF position, only a brief 30 sec cycle will be observed.

If it is desirable to observe a complete defrost in warmer weather, the defrost thermostat must be closed as follows.

1. Turn off power to outdoor unit and install lock-out tag.
2. Disconnect outdoor fan motor lead from OF2 on control board. (See Fig. 30) Tape to prevent grounding.

- Restart unit in Heating mode, allowing frost to accumulate on outdoor coil.
- After a few minutes in Heating mode, liquid line temperature should drop below closing point of defrost thermostat (approximately 30°F).

NOTE: Unit will remain in defrost until defrost thermostat reopens at approximately 80°F coil temperature at liquid line or remainder of defrost cycle time.

- Turn off power to outdoor and reconnect fan motor lead to OF2 on control board after above forced defrost cycle.

Defrost Thermostat

The defrost thermostat signals heat pump that conditions are right for defrost or that conditions have changed to terminate defrost. It is a thermally actuated switch clamped to outdoor coil to sense its temperature. Normal temperature range is closed at $30^{\circ} \pm 3^{\circ}\text{F}$ and open at $80^{\circ} \pm 5^{\circ}\text{F}$.

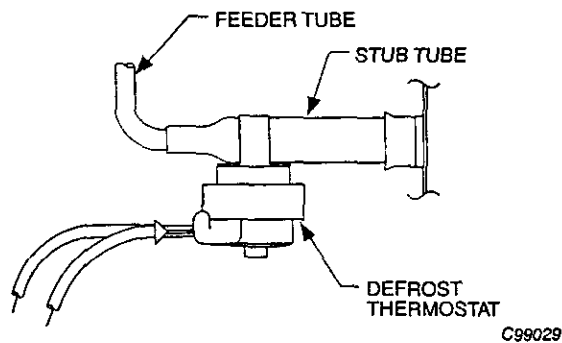

Fig. 31—Defrost Thermostat

NOTE: The defrost thermostat must be located on the liquid side of the outdoor coil on the bottom circuit and as close to the coil as possible.

Check Defrost Thermostat

There is a liquid header with a brass distributor and feeder tube going into outdoor coil. At the end of 1 of the feeder tubes, there is a 3/8-in. OD stub tube approximately 3 in. long (See Fig. 31). The defrost thermostat should be located on stub tube. Note that there is only 1 stub tube used with liquid header, and on most units it is the bottom circuit.

REFRIGERANT CIRCUIT

Annually inspect all refrigerant tubing connections and the unit base for oil accumulations. Detecting oil generally indicates a refrigerant leak.

▲ WARNING

System under pressure. Relieve pressure and recover all refrigerant before system repair or final unit disposal to avoid serious injury or death. Use all service ports and open all flow-control devices, including solenoid valves.

If oil is detected or if low cooling performance is suspected, leak-test all refrigerant tubing using an electronic leak-detector, halide torch, or liquid-soap solution. If a refrigerant leak is detected, refer to the *Check for Refrigerant Leaks* section.

If no refrigerant leaks are found and low cooling performance is suspected, refer to the *Checking and Adjusting Refrigerant Charge* section.

GAS INPUT

The gas input does not require checking unless improper heating performance is suspected. If a problem exists, refer to the *Start-Up* section.

INDOOR AIRFLOW

The heating and/or cooling airflow does not require checking unless improper performance is suspected. *If a problem exists, be sure that all supply- and return-air grilles are open and free from obstructions, and that the air filter is clean.* When necessary, refer to the *Indoor Airflow and Airflow Adjustments* section to check the system airflow.

PURON® SYSTEM ITEMS

METERING DEVICE — ACCURATER

This metering device is an AccuRater Piston (fixed orifice) and is contained in the brass hex-body in the liquid line.

PRESSURE SWITCHES

Pressure switches are protective devices wired into control circuit (low voltage). They shut off compressor if abnormally high or low pressures are present in the refrigeration circuit. These pressure switches are specifically designed to operate with Puron (R-410A) systems. R-22 pressure switches must not be used as replacements for the Puron (R-410A) system.

LOSS OF CHARGE SWITCH

This switch is located on the liquid line and protects against low suction pressures caused by such events as loss of charge, low airflow across indoor coil, dirty filters, etc. It opens on a pressure drop at about 20 psig. If system pressure is above this, switch should be closed. To check switch:

- Turn off all power to unit and install lock-out tag.
- Disconnect leads on switch.
- Apply ohm meter leads across switch. You should have continuity on a good switch.

NOTE: Because these switches are attached to refrigeration system under pressure, it is not advisable to remove this device for troubleshooting unless you are reasonably certain that a problem exists. If switch must be removed, remove and recover all system charge so that pressure gauges read 0 psi. Never open system without breaking vacuum with dry nitrogen.

HIGH-PRESSURE SWITCH

The high-pressure switch is located in the discharge line and protects against excessive outdoor coil pressure. It opens at 610 psig.

High pressure may be caused by a dirty outdoor coil, failed fan motor, or outdoor air recirculation.

To check switch:

- Turn off all power to unit and install lock-out tag.
- Disconnect leads on switch.
- Apply ohm meter leads across switch. You should have continuity on a good switch.

COPELAND SCROLL COMPRESSOR (PURON REFRIGERANT)

The compressor used in this product is specifically designed to operate with Puron (R-410A) refrigerant and cannot be interchanged.

The compressor is an electrical (as well as mechanical) device. Exercise extreme caution when working near compressors. Power should be shut off, if possible, for most troubleshooting techniques. Refrigerants present additional safety hazards.

⚠ WARNING

Wear safety glasses and gloves when handling refrigerants. Keep torches and other ignition sources away from refrigerants and oils. Failure to follow this warning can cause a fire, serious injury, or death.

The scroll compressor pumps refrigerant throughout the system by the interaction of a stationary and an orbiting scroll. The compressor is equipped with an anti-rotational device and an internal pressure relief port. The anti-rotational device prevents the scroll from turning backwards and replaces the need for a cycle protector. The pressure relief port is a safety device, designed to protect against extreme high pressure. The relief port has an operating range between 550 and 625 psi differential pressure.

The Copeland scroll compressor uses Mobil 3MA POE oil. This is the only oil allowed for oil recharge.

REFRIGERANT SYSTEM

This information covers the refrigerant system of the 48JZ, including the compressor oil needed, servicing systems on roofs containing synthetic materials, the filter drier and refrigerant charging.

Refrigerant

⚠ CAUTION

This system uses Puron (R-410A) refrigerant which has higher operating pressures than R-22 and other refrigerants. No other refrigerant may be used in this system. Gauge set, hoses, and recovery system must be designed to handle Puron. If you are unsure consult the equipment manufacturer. Failure to use Puron compatible servicing equipment or replacement components may result in property damage or injury.

Compressor Oil

The compressor in this system uses a polyolester (POE) oil, Mobil 3MA POE. This oil is extremely hygroscopic, meaning it absorbs water readily. POE oils can absorb 15 times as much water as other oils designed for HCFC and CFC refrigerants. Take all necessary precautions to avoid exposure of the oil to the atmosphere.

SERVICING SYSTEMS ON ROOFS WITH SYNTHETIC MATERIALS

POE (polyolester) compressor lubricants are known to cause long term damage to some synthetic roofing materials.

Exposure, even if immediately cleaned up, may cause embrittlement (leading to cracking) to occur in one year or more. When performing any service that may risk exposure of compressor oil to the roof, take appropriate precautions to protect roofing. Procedures which risk oil leakage include, but are not limited to, compressor replacement, repairing refrigerant leaks, replacing refrigerant components such as filter drier, pressure switch, metering device, coil, accumulator, or reversing valve.

Synthetic Roof Precautionary Procedure

1. Cover extended roof working area with an impermeable polyethylene (plastic) drip cloth or tarp. Cover an approximate 10 X 10 ft. area.
2. Cover area in front of the unit service panel with a terry cloth shop towel to absorb lubricant spills and prevent run-offs, and protect drop cloth from tears caused by tools or components.
3. Place terry cloth shop towel inside unit immediately under component(s) to be serviced and prevent lubricant run-offs through the louvered openings in the base.
4. Perform required service.
5. Remove and dispose of any oil contaminated material per local codes.

BI-FLOW FILTER DRIER

This bi-flow filter drier is specifically designed to operate with Puron. Use only factory-authorized components. This filter drier must be replaced whenever the refrigerant system is opened. When removing a filter drier, use a tubing cutter to cut the drier from the system. Do not unsweat a filter drier from the system. Heat from unsweating will release moisture and contaminants from drier into system.

PURON (R-410A) REFRIGERANT CHARGING

Refer to unit information plate and charging chart. Some R-410A refrigerant cylinders contain a dip tube to allow liquid refrigerant to flow from cylinder in upright position. For cylinders equipped with a dip tube, charge Puron units with cylinder in upright position and a commercial metering device in manifold hose. Charge refrigerant into suction-line.

TROUBLESHOOTING

Use the *Troubleshooting Guides* (See Tables 11-13) if problems occur with these units.

START-UP CHECKLIST

Use the *Start-Up Checklist* to ensure proper start-up procedures are followed.

HEAT PUMP WITH PURON—QUICK REFERENCE GUIDE

Puron refrigerant operates at 50-70 percent higher pressures than R-22. Be sure that servicing equipment and replacement components are designed to operate with Puron. Puron refrigerant cylinders are rose colored.

- Puron refrigerant cylinders manufactured prior to March 1, 1999, have a dip tube that allows liquid to flow out of cylinder in upright position. Cylinders manufactured March 1, 1999 and later DO NOT have a dip tube and MUST be positioned upside down to allow liquid to flow.
- Recovery cylinder service pressure rating must be 400 psig. DOT 4BA400 or DOT BW400.
- Puron systems should be charged with liquid refrigerant. Use a commercial type metering device in the manifold hose.
- Manifold sets should be 750 psig high-side and 200 psig low-side with 520 psig low-side retard.
- Use hoses with 750 psig service pressure rating.
- Leak detectors should be designed to detect HFC refrigerant.
- Puron, as with other HFCs, is only compatible with POE oils.
- Vacuum pumps will not remove moisture from oil.
- Only use factory specified liquid-line filter driers with rated working pressures no less than 600 psig.
- Do not install a suction-line filter drier in liquid line.
- POE oils absorb moisture rapidly. Do not expose oil to atmosphere.
- POE oils may cause damage to certain plastics and roofing materials.
- Wrap all filter driers and service valves with wet cloth when brazing.
- A Puron liquid-line filter drier is required on every unit.
- Do not use an R-22 TXV.
- **Never** open system to atmosphere while it is under a vacuum.
- When system must be opened for service, break vacuum with dry nitrogen and replace filter driers.
- Do not vent Puron into the atmosphere.
- Observe all **warnings, cautions, and bold text.**
- Do not leave Puron suction line driers in place for more than 72 hrs.

Table 11—Troubleshooting Guide—Cooling

| SYMPTOM | CAUSE | REMEDY |
|--|--|---|
| Compressor and outdoor fan will not start. | Power Failure | Call power company. |
| | Fuse blown or circuit breaker tripped | Replace fuse or reset circuit breaker. |
| | Defective thermostat, contactor, transformer, or control relay | Replace component. |
| | Insufficient line voltage | Determine cause and correct. |
| | Incorrect or faulty wiring | Check wiring diagram and rewire correctly. |
| Compressor will not start but outdoor fan runs. | Thermostat setting too high | Lower thermostat setting below room temperature. |
| | Faulty wiring or loose connections in compressor circuit | Check wiring and repair or replace. |
| | Compressor motor burned out, seized, or internal overload open | Determine cause after allowing time for overload to cool and close Replace compressor. |
| | Defective run/start capacitor, overload, start relay | Determine cause and replace. |
| Compressor cycles (other than normally satisfying thermostat). | One leg of 3-phase power dead | Replace fuse or reset circuit breaker. Determine cause. |
| | Refrigerant overcharge or undercharge | Recover refrigerant, evacuate system, and recharge to capacities shown on nameplate. |
| | Defective compressor | Replace and determine cause. |
| | Insufficient line voltage | Determine cause and correct. |
| | Blocked outdoor coil | Determine cause and correct. |
| | Defective run/start capacitor, overload or start relay | Determine cause and replace. |
| | Defective thermostat | Replace thermostat. |
| | Faulty outdoor-fan motor or capacitor | Replace. |
| Restriction in refrigerant system | Locate restriction and remove. | |
| Compressor operates continuously. | Dirty air filter | Replace filter. |
| | Unit undersized for load | Decrease load or increase unit size. |
| | Thermostat set too low | Reset thermostat. |
| | Low refrigerant charge | Locate leak, repair, and recharge. |
| | Air in system | Recover refrigerant, evacuate system, and recharge. |
| | Outdoor coil dirty or restricted | Clean coil or remove restriction . |
| Excessive head pressure. | Dirty air filter | Replace filter. |
| | Dirty outdoor coil | Clean coil. |
| | Refrigerant overcharged | Recover excess refrigerant. |
| | Air in system | Recover refrigerant, evacuate system, and recharge. |
| | Outdoor coil air restricted or air short-cycling | Determine cause and correct. |
| Head pressure too low. | Low refrigerant charge | Check for leaks, repair, and recharge. |
| | Compressor scroll plates cracked | Replace compressor. |
| | Restriction in liquid tube | Remove restriction. |
| Excessive suction pressure. | High heat load | Check for source and eliminate. |
| | Refrigerant overcharged | Recover excess refrigerant. |
| Suction pressure too low. | Dirty air filter | Replace Filter. |
| | Low refrigerant charge | Check for leaks, repair, and recharge. |
| | Metering device or low side restricted | Remove source of restriction. |
| | Insufficient indoor airflow | Increase air quantity. Check filter — replace if necessary. |
| | Temperature too low in conditioned area | Reset thermostat. |
| | Outdoor ambient below 40°F (55°F with ICM FIOP) | Install low-ambient kit . |
| | Factory-installed filter-drier restricted | Replace. |

Table 12—Troubleshooting Guide—Heating

| SYMPTOM | CAUSE | REMEDY |
|------------------------------------|--|--|
| Burners will not ignite. | Water in gas line | Drain. Install drip leg. |
| | No power to furnace | Check power supply fuses, wiring, or circuit breaker. |
| | No 24-v power supply to control circuit | Check transformer. NOTE: Some transformers have internal over-current protection that requires a cool-down period to reset. |
| | Mis-wired or loose connections | Check all wiring and wire nut connections |
| | Burned-out heat anticipator in thermostat | Replace thermostat. |
| | Broken thermostat wire | Run continuity check. Replace wire if necessary. |
| | Misaligned spark electrodes | Check flame ignition and sense electrode positioning. Adjust as necessary. |
| | No gas at main burners | 1. Check gas line for air. Purge as necessary. NOTE: After purging gas line of air, wait at least 5 minutes for any gas to dissipate before attempting to light unit. 2. Check gas valve. |
| Inadequate heating. | IGC board not allowing spark | Verify IGC has 24-v. at "W" & "E" If so, replace IGC |
| | Dirty air filter | Clean or replace filter as necessary. |
| | Gas input to furnace too low | Check gas pressure at manifold match with that on unit nameplate. |
| | Unit undersized for application | Replace with proper unit or add additional unit. |
| | Restricted airflow | Clean or replace filter. Remove any restriction. |
| | Blower speed too low | Use faster speed tap if available, or install alternate motor. |
| Poor flame characteristics. | Limit switch cycles main burners | Check rotation of blower, thermostat heat anticipator settings, temperature rise of unit. Adjust as necessary. —or— Verify use of proper thermostat – Thermidistat™ or dual-fuel thermostat must be used. |
| | Incomplete combustion results in: Aldehyde odors, carbon monoxide, sooting flame, floating flame | 1. Tighten all screws around burner compartment. 2. Cracked heat exchanger. Replace. 3. Unit over-fired. Reduce input (change orifices or adjust gas line or manifold pressure). 4. Check burner alignment. |

Table 13—Troubleshooting Guide—LED Error Codes

| SYMPTOM | CAUSE | REMEDY |
|---|---|--|
| Hardware failure. (LED OFF) | Loss of power to control module (IGC)*. | Check 5-amp fuse on IGC*, power to unit, 24-v circuit breaker, and transformer. Units without a 24-v circuit breaker have an internal overload in the 24-v transformer. If the overload trips, allow 10 minutes for automatic reset. |
| Fan ON/OFF delay modified (LED 1 FLASH) | High limit switch opens during heat exchanger warm-up period before fan-on delay expires. Limit switch opens within three minutes after blower-off delay timing in Heating mode. | Ensure unit is fired on rate; ensure temperature rise is correct. Ensure unit's external static pressure is within application guidelines. |
| Limit switch faults. (LED 2 flashes) | High temperature limit switch is open. | Check the operation of the indoor fan motor. Ensure that the supply-air temperature rise is in accordance with the range on the unit nameplate. |
| Flame sense fault. (LED 3 flashes) | The IGC* sensed flame that should not be present. | Reset unit. If problem persists, replace control board. |
| 4 consecutive limit switch faults. (LED 4 flashes) | Inadequate airflow to unit | Check operation of indoor fan motor and that supply-air temperature rise agrees with range on unit nameplate information. |
| Ignition lockout. (LED 5 flashes) | Unit unsuccessfully attempted ignition for 15 minutes. | Check ignitor and flame sensor electrode spacing, gaps, etc. Ensure that flame sense and ignition wires are properly terminated. Verify that unit is obtaining proper amount of gas. |
| Induced-draft motor fault. (LED 6 flashes) | IGC does not sense that induced-draft motor is operating.* | Check for proper voltage. If motor is operating, check the speed sensor plug/IGC Terminal J2 connection. Proper connection: PIN 1 — White PIN 2 — Red PIN 3 — Black. |
| Rollout switch fault. (LED 7 flashes) | Rollout switch has opened. | Rollout switch will automatically reset, but IGC* will continue to lock-out unit. Check gas valve operation. Ensure that induced-draft blower wheel is properly secured to motor shaft. Reset unit at unit disconnect. |
| Rollout control fault. (LED 8 flashes) | Microprocessor has sensed an error in the software or hardware. | If error code is not cleared by resetting unit power, replace the IGC*. |
| 9 Flashes | Redundant Safety Circuit Software Malfunction | Internal processor fault that will reset itself in 1 hour. Fault can be caused by stray RF signals in the structure or nearby. This is a UL Requirement. |

* **WARNING** ⚠ : If the IGC must be replaced, be sure to ground yourself to dissipate any electrical charge that may be present before handling new control board. The IGC is sensitive to static electricity and may be damaged if the necessary precautions are not taken.

IMPORTANT: Refer to Table 12—Troubleshooting Guide—Heating for additional troubleshooting analysis.

LEGEND

IGC — Integrated Gas Unit Controller

LED — Light-Emitting Diode

START-UP CHECKLIST
(Remove and Store in Job File)

I. PRELIMINARY INFORMATION

MODEL NO:
SERIAL NO:
DATE:
TECHNICIAN/JOB LOCATION:.....

II. PRE-START-UP (insert checkmark in box as each item is completed)

- ___ VERIFY THAT ALL PACKING MATERIALS HAVE BEEN REMOVED FROM UNIT
- ___ REMOVE ALL SHIPPING HOLD-DOWN BOLTS AND BRACKETS PER INSTALLATION INSTRUCTIONS
- ___ MAKE SURE THAT-ON 060 SIZE ONLY-THE TWO WIRE TIES FASTENED TO THE OUTDOOR COILS AND REVERSING VALVE / ACCUMULATOR ASSEMBLY HAVE BEEN REMOVED
- ___ VERIFY THAT CONDENSATE CONNECTION IS INSTALLED PER INSTALLATION INSTRUCTIONS
- ___ CHECK ALL ELECTRICAL CONNECTIONS AND TERMINALS FOR TIGHTNESS
- ___ CHECK GAS PIPING FOR LEAKS
- ___ CHECK THAT INDOOR AIR FILTER IS CLEAN AND IN PLACE
- ___ VERIFY THAT UNIT INSTALLATION IS LEVEL
- ___ CHECK FAN WHEEL PROPELLER FOR LOCATION IN HOUSING ORIFICE AND SETSCREW TIGHTNESS
- ___ SET OUTDOOR-AIR SENSOR SETTING TO PROPER SELECTION BASED ON BALANCE POINT PER THE THERMOSTAT INSTALLATION INSTRUCTIONS

III. START-UP

ELECTRICAL

SUPPLY VOLTAGE L1-L2 _____ L2-L3 _____ L3-L1 _____
COMPRESSOR AMPS L1 _____ L2 _____ L3 _____
COMPRESSOR AMPS C _____ S _____ R _____
INDOOR FAN AMPS _____

TEMPERATURES

OUTDOOR AIR TEMPERATURE: _____ DB _____ WB
RETURN-AIR TEMPERATURE: _____ DB _____ WB
COOLING SUPPLY AIR: _____ DB _____ WB
GAS HEAT SUPPLY AIR: _____

PRESSURES

GAS INLET PRESSURE _____ IN. WG
GAS MANIFOLD PRESSURE _____ IN. WG
REFRIGERANT SUCTION _____ PSIG SUCTION LINE TEMP* _____
REFRIGERANT DISCHARGE _____ PSIG DISCHARGE LINE TEMP† _____

___ VERIFY REFRIGERANT CHARGE USING CHARGING TABLES

* Measured at suction inlet to compressor

† Measured at liquid line leaving outdoor coil

Manufacturer reserves the right to discontinue, or change at any time, specifications or designs without notice and without incurring obligations.