

Owner's Manual

NOTE TO INSTALLER: THIS MANUAL MUST BE LEFT WITH THE EQUIPMENT USER.

USER: Please read all instructions in the manual and retain all manuals for future reference.

⚠ WARNING

FIRE OR EXPLOSION HAZARD

Failure to follow safety warnings could result in injury, death, or property damage.

Do not store or use gasoline or other flammable vapors and liquids in the vicinity of this or any other appliance.

WHAT TO DO IF YOU SMELL GAS

- Do not try to light any appliance.
- Do not touch any electrical switch; do not use any phone in your building.
- Leave the building immediately.
- Immediately call your gas supplier from a neighbor's phone. Follow the gas supplier's instructions.
- If you cannot reach your gas supplier, call the fire department.

Installation and service must be performed by a qualified installer, service agency or the gas supplier.

⚠ WARNING

CARBON MONOXIDE POISONING HAZARD

Failure to follow this warning could result in personal injury and/or death.

Carbon Monoxide is invisible, odorless, and toxic! A carbon monoxide alarm is recommended in your home, even if you do not own a gas appliance. Locate the carbon monoxide alarm in the living area of your home and away from gas appliances and doorways to attached garages. Follow the alarm manufacturer's instruction included with the alarm.

Do not use this furnace if any part has been under water. A flood-damaged furnace is extremely dangerous. Attempts to use the furnace can result in fire or explosion. A qualified service agency should be contacted to inspect the furnace and to replace all gas controls, control system parts, electrical parts that have been wet or the furnace if deemed necessary.



As an ENERGY STAR® Partner, we have determined that this product meets the ENERGY STAR® guidelines for energy efficiency.

SAFETY CONSIDERATIONS

Recognize safety information. This is the safety-alert symbol **⚠**. When you see this symbol on the furnace and in instructions or manuals, be alert to the potential for personal injury.

Understand the signal words: DANGER, WARNING, and CAUTION. DANGER identifies the most serious hazards which **will** result in severe personal injury or death. WARNING signifies hazards which **could** result in personal injury or death. CAUTION is used to identify unsafe practices which **may** result in minor personal injury or product and property damage. NOTE is used to highlight suggestions which **will** result in enhanced installation, reliability or operation.

To minimize the possibility of serious personal injury, fire, furnace damage, or improper operation; **carefully follow these safety rules:**

- Your gas furnace uses air from outside the home for combustion and vents flue gas to the outdoors. It is not to be installed using indoor air for combustion. The vent pipe must terminate outside the structure and must not be obstructed in any way. The air-intake pipe must terminate outside the structure or in a well ventilated area that is isolated from the living space and the garage (e.g. well ventilated attic or crawlspace). Do not block or obstruct air openings on furnace or spaces around furnace.
- Keep the area around your furnace clear and free of combustible materials, gasoline, and other flammable liquids and vapors.

Combustion Air (Your Safety)

WARNING

CARBON MONOXIDE POISONING HAZARD

Failure to follow this warning could result in personal injury or death.

All fuel-burning appliances must be provided with enough fresh air for proper combustion and ventilation of flue gases.

Some models use air from the space in which they are located, and other appliances in the same space may also be using indoor air for ventilation and/or combustion.

PG9YAA

New materials and methods are being used in construction and remodeling which result in lower energy costs for heating and cooling. It may also mean your appliances may not be getting enough air for combustion and ventilation of flue gases. The use of exhaust fans, fireplaces, clothes dryers, and other appliances consume air or vent it to the outdoors.

If the gas appliances or heating furnace can't get enough air, two conditions may result:

1. The appliances or furnace may produce carbon monoxide gas.
2. The appliance may not vent flue gases properly. The following are signs that your appliances may not be getting enough air for proper combustion.

Be aware of these signals:

1. Headaches, Nausea, Dizziness
2. Excessive humidity--heavily frosted windows or a moist "clammy" feeling in the structure.
3. Smoke from the fireplace won't draw up the chimney.

WARNING

CARBON MONOXIDE POISONING HAZARD

Failure to follow this warning could result in personal injury or death.

If you experience headaches, nausea, or dizziness, carbon monoxide may be present. Leave the house immediately and call your gas supplier.

Combustion Air Checks

If any of the above signals are noticed, perform a combustion air check or call a qualified service agency. If you add weather stripping, storm windows, insulation, an additional fuel burning appliance, or remodel the structure, a combustion air check **MUST** be accomplished after the addition.

Make the inspection as follows:

1. Close all doors and windows. If you have a fireplace, start a fire and wait until flames are burning vigorously.
2. Turn on all exhausting devices, such as: kitchen and bathroom exhaust fans and dryers (gas or electric).
3. Turn on all vented gas appliances, such as: heating equipment (includes any room heaters) and water heaters.
4. Wait ten (10) minutes for drafts to stabilize.
5. On appliances with a draft hood, check for spillage by holding a lighted match 2" (50.8 mm) from the draft hood opening. Reference Fig. 1, which shows a water heater draft hood.

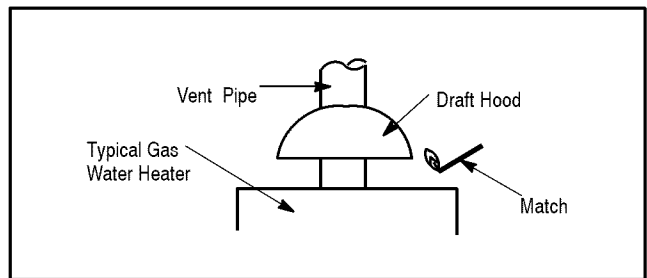

A07688

Fig. 1 - Water Heater Draft Hood

- a. *Match flame pulls toward draft hood.*
This indicates no spillage and that appliance is getting enough air for combustion. Return exhausting devices and appliances to the condition in which you found them.
- b. *Match goes out or flame wavers away from draft hood.*
This indicates spillage and that appliance is not getting enough air for combustion.

WARNING

CARBON MONOXIDE POISONING HAZARD

Failure to follow this warning could result in personal injury or death.

Draft hood spillage means there is not enough air for proper combustion and carbon monoxide may be present.

Keep a window open a minimum of 2" (50.8 mm) near the appliance until a permanent combustion air duct is installed. Contact a qualified service agency.

If draft hood spillage is indicated:

1. Check for plugged vent connectors and chimneys. Repair stoppage and test again.
2. If you have a fireplace, open a window or door near the fireplace and then check for spillage. If spillage stops, do not use the fireplace until you can supply fresh air by a permanent duct.
3. If you have kitchen and bathroom exhaust fans, turn them OFF and check for spillage. If spillage stops, do not use exhaust fans until you can supply fresh air by a permanent duct. Circuit breakers for fans should be turned off and marked as to why they are off.
4. Spillage means air starvation and that an outdoor air duct or air intake must be installed to provide air directly to the area around the furnace. This duct or intake **MUST** comply with local and state building codes or in their absence with the National Fuel Gas Code NFPA 54/ANSI Z223.1-2006 in the U.S., or the National Standard of Canada, Natural Gas and Propane Installation Code CSA B-149.1-2006 in Canada.

Indoor Humidity (Your Comfort)

Relative humidity is important to your health. Proper humidification helps cut down incidences of respiratory illness. Air that is too wet may damage the building structure. Air that is too dry is uncomfortable. A quick way to test for proper humidity is as follows:

1. Look for frequent fogging or excessive condensation on the inside of windows. This indicates the indoor humidity level is too high for outdoor weather conditions.
2. Drop three ice cubes into a glass of water and stir. If, within three minutes, moisture does not form on the glass, the air is too dry and a humidifier would be beneficial. (Do not per-

form this test in the kitchen, cooking vapors may produce inaccurate results.)

A good relative humidity is one just high enough to barely start condensation along the lower edges or lower corners of the windows, when it is cold outside. More than that can be damaging. If the humidity is too high, try these suggestions to lower the humidity:

1. Reduce setting or discontinue use of humidifier.
2. Use range and bathroom exhaust fans while cooking and bathing. Open a door or window for a few minutes to bring in cool drier air.
3. Cook with pans covered.
4. Take shorter baths or showers with cooler water.
5. Install a fresh air intake duct. Cold, dry air brought in from outside to the furnace area lowers the indoor humidity level.
6. Have appliances checked. A malfunctioning appliance can contribute water vapor to the structure.
7. If the problem continues, consult a heating contractor about adding a heat recovery ventilator or air-to-air heat exchanger.

About Your Furnace

Fig. 2 shows the location of the components in the furnace.

Circulating Air Blower

The blower circulates room air through the furnace, air ducts, and into the rooms of the structure. The blower can be set at the thermostat for automatic or manual operation. In manual mode the blower operates continuously. In automatic, the blower does not come on until a preset time after the gas valve is energized. When the structure reaches the temperature set on the thermostat, the furnace will shut off. The blower will continue to run until the furnace cools down.

Thermostat

There are many types and styles of thermostats. Most thermostats control both heating and cooling functions and have a Fan Switch with AUTO and ON settings. On AUTO, the Circulating Air Blower will cycle on/off with the furnace on the heating speed unless a call for cooling is initiated. Blower speed will correspond to the mode of operation of the furnace. If the Fan Switch is positioned to ON the blower will run continuously.

In addition some thermostats are programmable with multiple set backs. The set backs can be pre-programmed to lower or raise the temperature automatically.

Be sure to become familiar with your thermostat.

Rating Plate

The rating plate contains important information for the service technician and lists the complete model, manufacturing and serial numbers. You should always provide all these numbers when requesting parts or if you need service. See Fig. 2 for rating plate location.

Door Interlock Switch

All the electrical power for the furnace goes through the door interlock switch. The interlock switch interrupts electrical power to the furnace when the blower door is removed. The furnace will not operate until the blower door is reinstalled.

Furnace Control

The furnace control provides power to the circulating air blower to keep it on until the furnace cools down.

The fan off-delay setting can be adjusted if the fan remains on long enough that cool drafts are felt in the room after the furnace shuts off.

PG9YAA

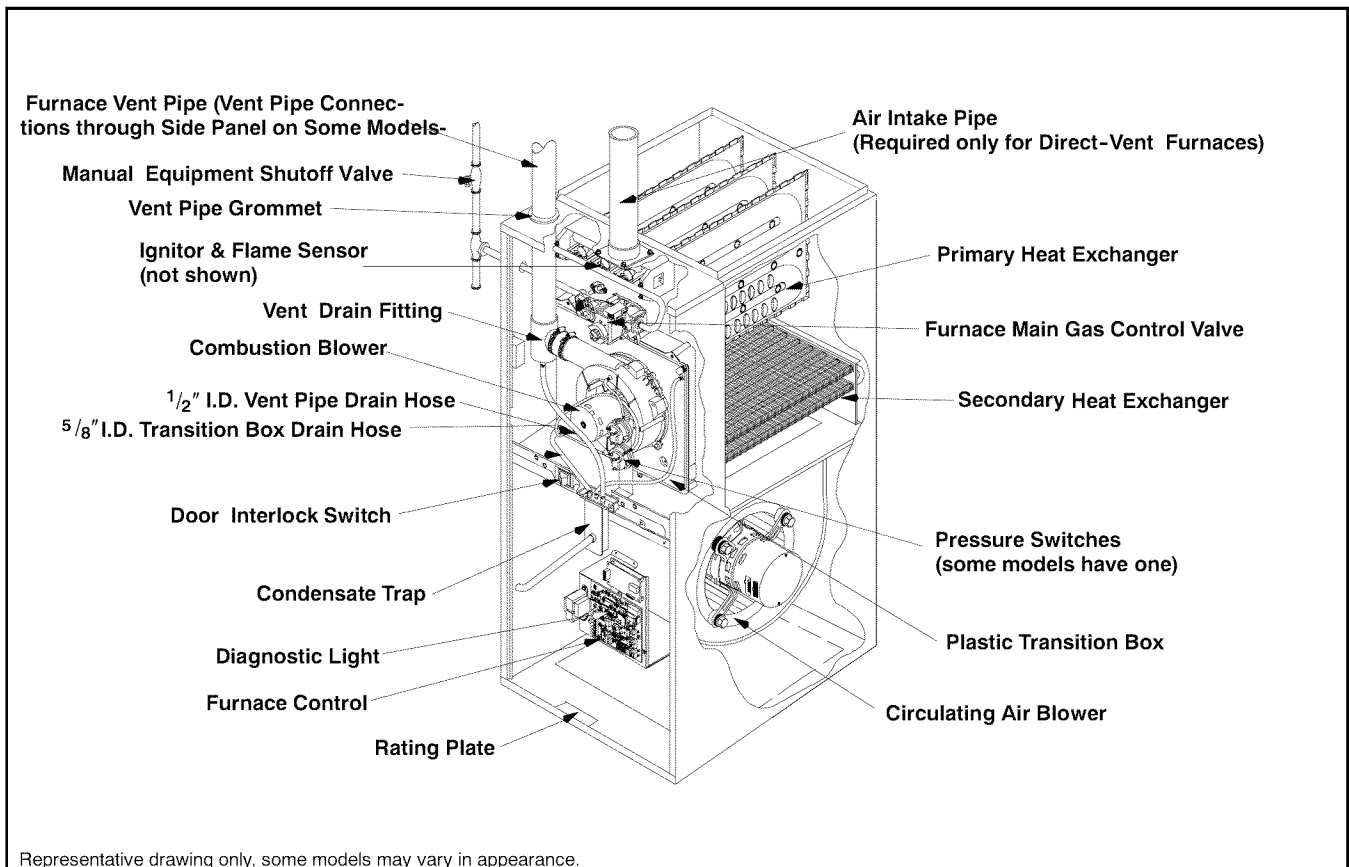

Representative drawing only, some models may vary in appearance.

Fig. 2 - Component Locations for Condensing 90+ Furnaces

A07689

The off-delay is set by moving a jumper on the control. The Wiring Diagram located on the inside of the blower door shows the various delay combinations. Refer to Fig. 2 for location of the control.

If you are unsure how to set the Off-delay Control, contact a Qualified Service Agency.

Set the room thermostat slightly above room temperature. This will automatically signal the furnace to start. The inducer motor will start, and the hot surface igniter will have an orange glow. After about 32 seconds (from the call for heat at the thermostat), the gas valve permits gas to flow to the main burners where it is ignited. When the flame is firmly established, the igniter shuts off. Hot flames begin to warm the furnace's heat exchanger. After a time delay of 30 seconds, the furnace blower is switched on.

NOTE: If the main burners fail to ignite, the furnace control system will go through 3 more ignition cycles. Then, if burners fail to ignite, the system will lockout. If lockout occurs, or the blower doesn't come on, shut down your furnace and call a Qualified Service Agency for service.

Pressure Switch

The furnace is equipped with one or more pressure switches to shut down the furnace under various flue conditions. The switches are connected to the furnace by factory supplied tubing.

Operating Your Furnace

Keep the blower access door and all access panels in place except for inspection or maintenance.

Before starting your furnace be sure you read and understand all of the procedures in this manual. Check to make sure the furnace filter is clean and correctly installed.

⚠ WARNING

CARBON MONOXIDE POISONING HAZARD

Failure to follow this warning could result in personal injury or death.

Provisions for combustion and ventilation air must be provided for in accordance with installation instructions supplied with furnace.

Starting The Furnace

See Fig. 4 for an illustration of the gas control valve.

1. Turn the thermostat to its lowest temperature setting or to OFF if equipped with a System Select Switch.
2. Turn OFF all electric power to the furnace at the disconnect switch or circuit breaker.
3. Remove the burner compartment door by removing the two(2) screws securing the door in front and lifting the door up and outwards. Removing the door will expose the gas control valve knob.
4. Turn the gas control valve to the OFF position. See Fig. 4.
5. Wait five (5) minutes to clear out any gas. If you then smell gas, STOP! Follow the safety information on the cover of this manual. If you do not smell gas, go to the next step.
6. Turn the gas control valve to the ON position. See Fig. 4.
7. Reinstall all doors.
8. Turn ON all electrical power to the furnace.
9. Set the thermostat to the desired temperature and the System Select Switch to HEAT.

The furnace will activate an igniter which lights the main burners.

Turning Off The Furnace

Set the thermostat to the lowest temperature setting or set System Select Switch to OFF, if so equipped.

Should overheating occur or the gas control valve fail to shut off, shut off the manual equipment shutoff valve to the furnace before shutting off the electrical supply.

Extended Shutdown

1. Set thermostat to lowest temperature setting or set thermostat System Select Switch to OFF, if so equipped.
2. Turn Manual Equipment Shutoff Valve for furnace to OFF position (at right angle or 90° to gas line).
3. Remove the burner compartment door by removing the two (2) screws securing the door in front and lifting the door up and outwards. Removing the door will expose the gas control valve knob.
4. Turn OFF electric power to the furnace at the disconnect switch or circuit breaker. (May be left ON for set-back type thermostat with batteries, provided thermostat has system select switch placed in the OFF position.)
5. Turn the the gas control valve to the OFF position. See Fig. 3.
6. Reinstall all doors.

Propane Gas Model Furnaces

⚠ WARNING

FIRE OR EXPLOSION HAZARD

Failure to follow this warning could result in property damage, personal injury or death.

Propane gas is heavier than air. Leaking gas could settle in low areas such as crawl space. If you suspect the presence of gas, follow the instructions on the cover of this manual.

If your propane gas furnace is installed in an excavated or low lying area, we recommend that you contact your propane gas supplier about installing a warning device that would alert you of a gas leak.

Frozen Water Pipe Hazard

⚠ CAUTION

PROPERTY DAMAGE HAZARD

Failure to follow this caution may result in property damage

Furnace may shut down. Do not leave your home unattended for long periods during freezing weather without turning off water supply and draining water pipes or otherwise protecting against the risk of frozen pipes.

Your furnace is designed solely to provide a safe and comfortable living environment. The furnace is NOT designed to ensure that water pipes will not freeze. It is equipped with several safety devices that are designed to turn the furnace off and prevent it from restarting in the event of various potentially unsafe conditions.

If your furnace remains off for an extended time, the pipes in your home could freeze and burst, resulting in water damage. If the structure will be unattended during cold weather, you should take these precautions.

1. Turn off the water supply to the structure and drain the water lines if possible and add an antifreeze for potable water to drain traps and toilet tanks. Open faucets in appropriate areas.

–or–

Single Stage

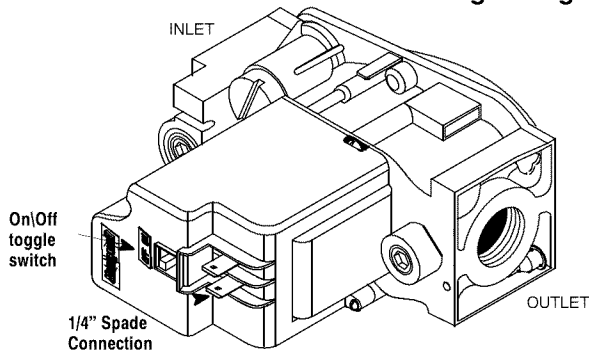

Fig. 3 - Gas Control Valve

A07694

2. Have someone check the structure frequently during cold weather to make sure it is warm enough to prevent pipes from freezing. Instruct them to call a qualified service agency to call to provide service, if required.

-or-

3. Install a reliable remote sensing device that will notify somebody of freezing conditions within the home.

Winter Shutdown (90+ Furnaces)

If you go away during the winter months and do not leave the heat on in your home, the plastic transition box and the condensate trap on the furnace must be protected from freeze damage. (See Fig. 2)

1. Disconnect the 1/2" I.D. rubber hose from the vent drain fitting (or tee) that is located downstream of the combustion blower. Insert a funnel into the hose and pour four (4) ounces of sanitary type (RV) antifreeze into the condensate trap. Reconnect the 1/2" I.D. rubber hose to the stub on the vent drain fitting. Secure with the hose clamp.
2. Disconnect the 5/8" I.D. rubber hose from the condensate trap. Insert a funnel into the hose and pour four (4) ounces of sanitary type (RV) antifreeze into the plastic transition box. Squeeze the hose together near the end and quickly reconnect the 5/8" I.D. rubber hose to the stub on the condensate trap. Secure with the hose clamp.
3. When you return home, your furnace will be ready to start, as it is not necessary to drain the antifreeze from the furnace.

Furnace Maintenance

Have your furnace inspected and serviced on an annual basis (before the heating season) by a qualified service agency.

Labeling

⚠ WARNING

FIRE OR EXPLOSION HAZARD

Failure to follow this warning could result in personal injury or death.

Label all wires prior to disconnection when servicing controls. Verify proper operation after servicing. Only qualified service agencies should attempt electrical service.

Pressure Switches

During regular yearly maintenance, check for cracks in any tubes on the pressure switches.

⚠ WARNING

ELECTRICAL SHOCK HAZARD

Failure to follow this warning could result in personal injury or death.

Turn off electrical power to furnace before performing any maintenance or removing panels or doors.

Air Filters/Monthly

The air filter(s) should be inspected at least monthly and cleaned or replaced as required. There are many types of filters that are commonly used. Washable filters (constructed of aluminum mesh, foam, or reinforced fibers) may be cleaned by soaking in mild detergent and rinsing with water. The fiberglass disposable type should be REPLACED before it becomes clogged. Other filter types should be serviced in accordance with the manufacturer's recommendations.

Remember that dirty filters are the most common cause of inadequate heating or cooling performance.

Replacement Filters

If the filter is not located at or within the furnace, it should be located somewhere in the return-air duct system.

The recommended sizes and types of filters that may be used with your furnace are based on the furnace's heating gas input rate (and cooling system capacity, if so equipped).

Replacement filters should be of the same type and size as the original filters, to ensure adequate air flow and filtering. A disposable low velocity filter can be replaced with a washable high velocity type. Do not replace a high velocity filter with a disposable low velocity filter, except as permitted below.

If a cleanable (high-velocity) filter(s) is to be replaced with a disposable (low-velocity) filter(s), the airflow area of the filter(s) must be doubled (i.e., a second filter of the same size must be installed so that only half of the air goes through each filter). A second return-air duct to the furnace may be required in which to install the second filter. Modification of a furnace installation shall comply with the local installation code and the furnace installation instructions, and shall be made only by a Qualified Service Agency.

NOTE: Some filters are marked with an arrow to indicate the proper direction of air flow through the filter. The air flow direction will be towards the blower motor. Make sure filter is installed correctly.

Filter Replacement - Upflow

The filter may be installed inside the bottom of the furnace blower compartment, or the filter(s) rack may be installed under the furnace or on either or both sides of the furnace. A plastic end cap(s) is inserted in the filter rack(s) after the filter(s) is installed. The end cap keeps air from escaping around the open end of the filter rack. See Fig. 4 and Fig. 5 for side and bottom locations. Rack end cap is similar for bottom mounted filter rack.

Filter rack(s) attached to the outside of the furnace is made so the filter simply slides out one end for removal.

PG9YAA

▲ CAUTION

PROPERTY DAMAGE HAZARD

Failure to follow this warning could result in increase furnace operating temperatures and shorten the life of the furnace.

Filters specified for the furnace are rated at a maximum of 600 FPM air velocity and sized for the furnace's airflow rate. Replacement filters must be of equivalent type, size, and rating except as described below.

Disposable, low-velocity filters may be used to replace washable, high-velocity filters, providing they are sized for 300 FPM or less.

If you are uncertain of the type of replacement filter to use, consult the furnace installer or a qualified service agency for assistance.

PG9YAA

Filter Replacement - Bottom or Side Mounted Filter Rack Outside Furnace

1. Turn OFF electric power to furnace.
2. Remove the end cap from the filter rack.
3. Slide the filter out of the filter rack. See Fig. 4.
4. Inspect the filter(s) and replace or clean washable types. If filter is aluminum mesh it should be recoated with filter coating spray.

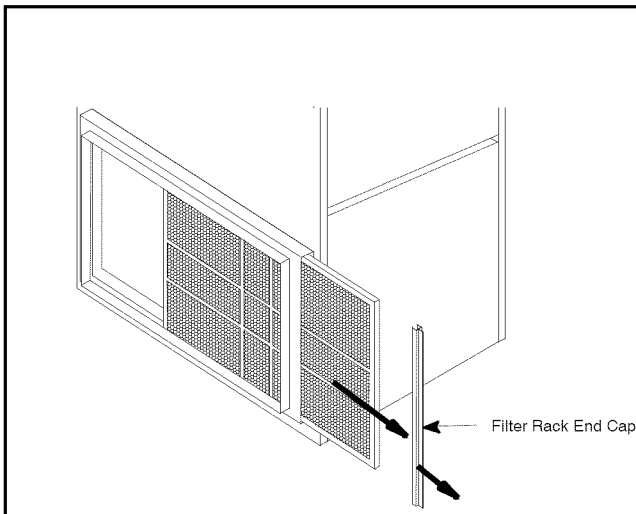

Fig. 4 - Filter Rack Outside Furnace

A07690

5. Reinstall the end cap in the filter rack.
6. Turn on electric power to furnace.

Filter Replacement - Bottom Mounted Filter Inside Furnace

1. Turn off electric power to furnace.
2. Remove blower door.
3. Slide filter straight out toward you. See Fig. 5.
4. Inspect the filter(s) and replace or clean washable types. If filter is aluminum mesh it should be recoated with filter coating spray.
5. Replace blower door.
6. Turn on electric power to furnace.

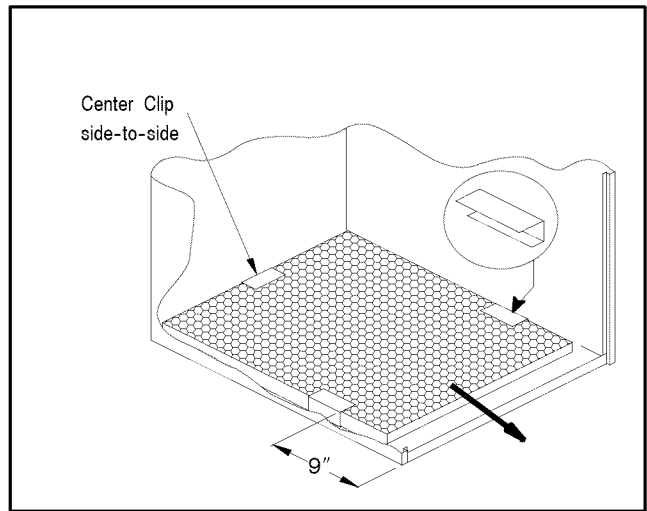

Fig. 5 - Bottom Mounted Filter Inside Furnace

A07691

External Filter Rack

A plastic end cap is inserted in the filter rack after the filter is installed. The end cap keeps air from escaping around the open end of the filter rack. See Fig. 4 for removal of filter.

Filter racks attached to the furnace are made so the filter simply slides out one end for removal.

1. Turn OFF electric power to furnace.
2. Remove the end cap from the filter rack.
3. Slide the filter out of the filter rack.
4. Inspect the filter(s) and replace or clean washable types. If filter is aluminum mesh it should be recoated with filter coating spray.
5. Reinstall the end cap in the filter rack.
6. Turn furnace on.

Internally Mounted Filter

1. Turn OFF power to furnace.
2. Remove blower door.
3. Slide filter straight out toward you. (See Fig. 5.)
4. Inspect the filter(s) and replace or clean washable types. If filter is aluminum mesh it should be recoated with filter coating spray.
5. Replace blower door.
6. Turn on electric power to furnace.

Lubrication

The blower motor and the combustion air blower are pre-lubricated by the manufacturer and DO NOT require oiling.

Qualified Service Agency Checks

When the furnace is being inspected for condition and operation have the Qualified Service Agency check the following items.

1. Check all flue gas passages including main and pilot burners, heat exchanger, and vent.
2. Check electrical wiring and connections.
3. Check supply and return air ducts for leakage, blockage and connections to furnace.
4. Check circulating air blower wheel and motor. Clean them if required.
5. Perform an operational checkout on the furnace to be sure safety controls function and that furnace operates properly.

For additional information, the Qualified Service Agency can consult the installation instructions for the furnace.

Recommended Filter Sizes		
Nominal Air Flow Cubic Feet per Minute (CFM)	Recommended Filter Sizes Nominal Size (inches/mm)	
	Disposable Filters	Cleanable Filters
800-900	20 x 25 (508.0 x 635.0) (1 Req.)	14 x 25 (355.6 x 635.0) (1 Req.)
1100-1300	14 x 25 (355.6 x 635.0) (2 Req.)	14 x 25 (355.6 x 635.0) (1 Req.)
1300-1500	16 x 18 (406.4 x 457.2) (2 Req.)	16 x 18 (406.4 x 457.2) (1 Req.)
1500-1700	20 x 25 (508.0 x 635.0) (2 Req.)	20 x 25 (508.0 x 635.0) (1 Req.)
1900-2100	20 x 30 (508.0 x 762.0) (2 Req.)	20 x 25 (508.0 x 635.0) (1 Req.)
2300-2500	20 x 30 (508.0 x 762.0) (2 Req.)	24 x 30 (609.6 x 762.0) (1 Req.)

Table 1 – Recommended Filter Sizes

PG9YAA

