

SET-UP INSTRUCTIONS and PRE-OPERATION CHECKLIST FOR SNAPPER LE MODEL SINGLE STAGE SNOW THROWERS

The Snapper LE snow throwers are shipped with the upper handle folded forward, and with the discharge chute and chute control handle detached. These machines are designed for quick set-up. No special tools are required. Carefully follow and complete each step. Review and complete each item as instructed on the Pre-Operation checklist. The Snapper Product Registration card must be filled out and sent to the Customer Service department at SNAPPER when completed.

STEP 1: Remove machine from shipping carton. Remove and discard cardboard from between all handles. The right side of upper handle is positioned on the outside of lower handle and should be moved to the inside of the lower handle. Eye of eye-bolt must be on right side of machine at lower handle. Raise upper handle until the lower ends seat into concave area of lower handle. Tighten handle knobs securely. Insert clean-out tool into holders on right handle. See Figure 1.

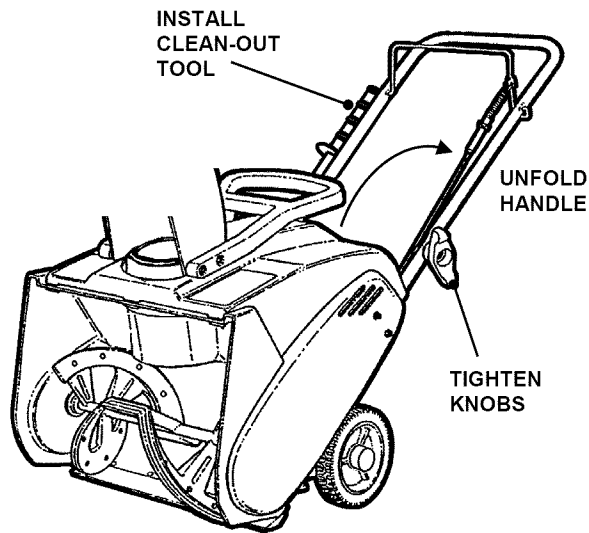

FIGURE 1

STEP 2: Install lower chute handle onto chute with two hex cap screws. Install chute/handle assembly onto discharge opening and secure with three carriage bolts and nuts. Tighten all nuts and bolts securely but, do not overtighten. See Figure 2.

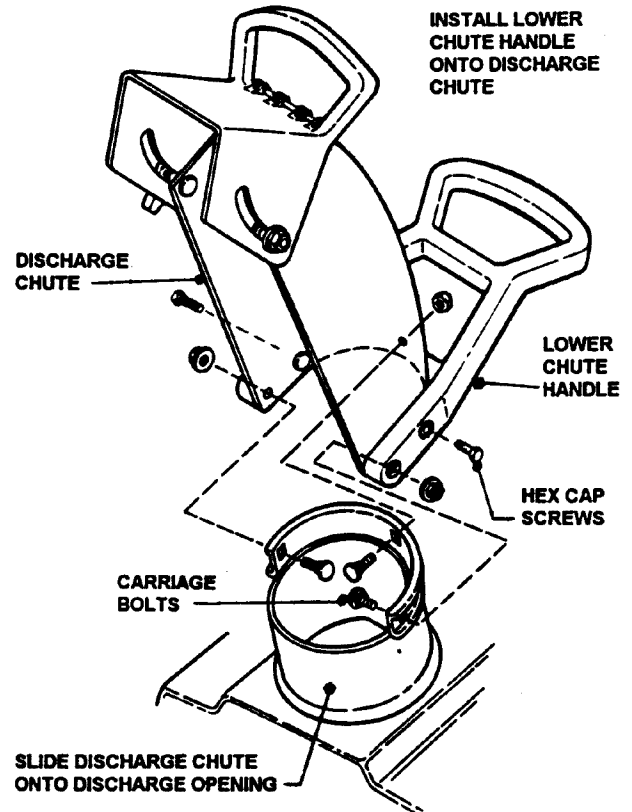

FIGURE 2

STEP 3: Measure auger clutch control cable extension from a relaxed position to full extended position. Proper extension should be between 1/2" minimum to 3/4" maximum extension. NOTE: Measure from the top of spring (The top is in relation to where spring hooks into auger clutch control). Loosen jam nut at the upper end of cable. Hold threaded end of cable and then turn cable clockwise until correct extension is achieved. Retighten jam nut. **IMPORTANT:** DO NOT over tighten cable. The cable must have slack for the auger brake to function properly. See Figure 3.

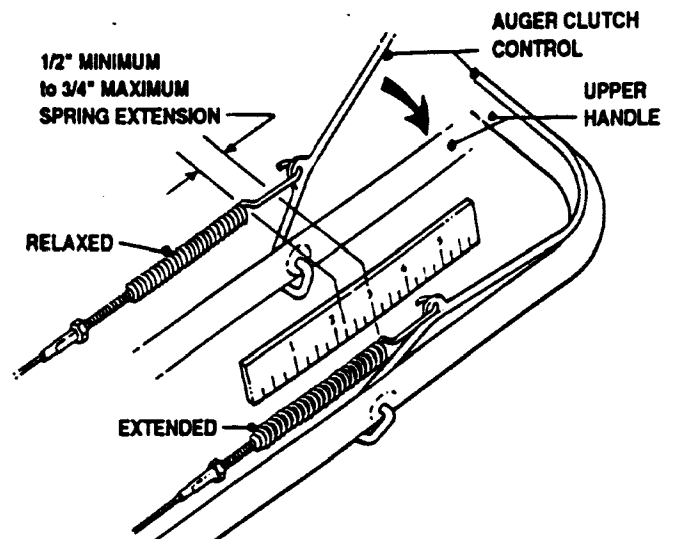

FIGURE 3

INSTRUCTION No. 7100948 (I.R. 6/26/2006)
TP 300-5206-00-SX-SN

PRE-OPERATION CHECKLIST for SNAPPER SINGLE STAGE SNOW THROWERS

Complete each of the following items prior to placing the machine into service. It is very important that setup is verified and all operational tests completed and results are acceptable. Check () all items actually performed. After completing this form, sign and retain for future reference.

SET-UP

- UPPER HANDLE & LOWER HANDLE secured in place and hardware tightened securely.
- DISCHARGE CHUTE and DEFLECTOR ASSEMBLY installed on snow thrower.
- CLEAN-OUT TOOL attached to handle on snow thrower.

LUBRICATION

- ENGINE OIL added to bring level up to full mark on 4-cycle engines (Refer to Engine Manual).
- OIL mixed with FUEL in specified ratio (2 Cycle Engines Only). (Refer to Engine Manual).

OPERATIONAL TEST

- AUGER checked to insure stopping within 5 seconds after clutch control is released.
- ENGINE started, engine control settings checked and adjusted as needed.
- FUEL SYSTEM checked for leaks around tank and connections.
- DISCHARGE CHUTE checked for free rotation.
- AUGER CONTROL CABLE adjusted per instructions in the Operator's Manual supplied with machine.

CONSUMER INFORMATION

Purchase Date _____ Model _____ Serial No. _____

Retailers Name _____

Address _____ City _____ State _____ Zip _____

MACHINE WILL BE USED COMMERCIALY? YES NO

Purchaser's Name _____ Signature _____

Address _____ City _____ State _____ Zip _____

IMPORTANT: This form is to be retained for future reference regarding Warranty, proof of purchase, traceability for product recall or service, etc. Complete the Snapper Product Registration Card and Mail to Customer Service Department at SNAPPER, P.O. BOX 1379, McDonough, Georgia, 30253.