

CTK-520L

ELECTRONIC MUSICAL INSTRUMENT
INSTRUMENTO MUSICAL ELECTRÓNICO

OPERATION MANUAL MANUAL DE OPERACIÓN

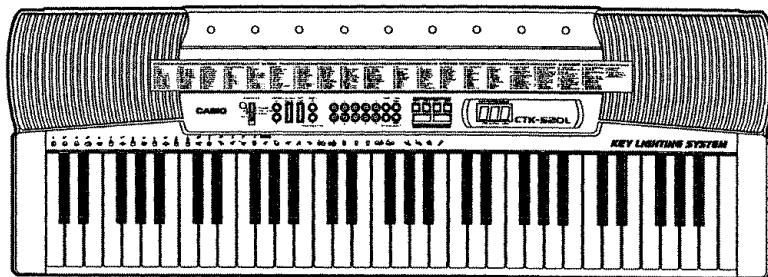

P



CTK520LES-1

CASIO.

Welcome...

To the happy family of satisfied CASIO electronic musical instrument owners! To get the most out of the many features and functions of the CTK-520L, be sure to carefully read this manual and keep it on hand for future reference.

Important!

Promptly replace the batteries or use the AC adaptor when the following symptoms occur.

- Dim power supply indicator
- Abnormally low speaker/headphone volume
- Distortion of sound output
- A totally different tone may sound
- Abnormal rhythm pattern and demo tune play
- Continued sound output even after you release a button
- Occasional interruption of sound when playing at high volumes
- Sudden power failure when playing at high volumes

Please keep all information for future reference.

GUIDELINES LAID DOWN BY FCC RULES FOR USE OF THE UNIT IN THE U.S.A (not applicable to other areas).

NOTICE

This equipment has been tested and found to comply with the limits for a Class B digital device, pursuant to Part 15 of the FCC Rules. These limits are designed to provide reasonable protection against harmful interference in a residential installation. This equipment generates, uses and can radiate radio frequency energy and, if not installed and used in accordance with the instructions, may cause harmful interference to radio communications. However, there is no guarantee that interference will not occur in a particular installation. If this equipment does cause harmful interference to radio or television reception, which can be determined by turning the equipment off and on, the user is encouraged to try to correct the interference by one or more of the following measures:

- Reorient or relocate the receiving antenna.
- Increase the separation between the equipment and receiver.
- Connect the equipment into an outlet on a circuit different from that to which the receiver is connected.
- Consult the dealer or an experienced radio/TV technician for help.

FCC WARNING

Changes or modifications not expressly approved by the party responsible for compliance could void the user's authority to operate the equipment.

Main Features

- 100 amazingly realistic tones**
- Enhanced auto-accompaniment function for greater versatility**
 - 50 built in auto-accompaniment patterns.
- 40 Built-in Song Bank tunes**
 - A total of 40 built-in Song Bank tunes come built in for playback enjoyment or play-along practice.
- A three-step lesson functions lets you develop your musical skills by following the keys as they light (Three Step Lesson System).**
 - First you become familiar with the timing of the notes by watching the keys light as you playback one of the 40 built-in Song Bank tunes. Next, practice playing along at a pace that's comfortable for you. Finally, try playing along at the normal tempo for the Song Bank tune.
- Auto Accompaniment**
 - Simply specify a chord and the keyboard automatically produces the matching rhythm, bass, and chord patterns. One-touch fill-ins make accompaniments sound interesting and natural.
- Transpose Function**
 - An easy operation instantly changes the key of the keyboard.

Safety Precautions

Symbols

Various symbols are used in this operating manual and on the product itself to ensure that the product is used safely and correctly, and to prevent injury to the user and other persons as well as damage to property. Those symbols along with their meanings are shown below.



WARNING

This indication stipulates matters that have the risk of causing death or serious injury if the product is operated incorrectly while ignoring this indication.



CAUTION

This indication stipulates matters that have the risk of causing injury as well as matters for which there is the likelihood of occurrence of physical damage only if the product is operated incorrectly while ignoring this indication.

Symbol Examples



This triangle symbol (△) means that the user should be careful. (The example at left indicates electrical shock caution.)



This circle with a line through it (⊘) means that the indicated action must not be performed. Indications within or nearby this symbol are specifically prohibited. (The example at left indicates that disassembly is prohibited.)



The black dot (●) means that the indicated action must be performed. Indications within this symbol are actions that are specifically instructed to be performed. (The example at left indicates that the power plug must be unplugged from the electrical socket.)



WARNING

Please use caution regarding the handling of the AC adaptor.

- Do not use a voltage other than the indicated power supply voltage. Use of a voltage other than that indicated may cause fire or electrical shock.
- If the power cord should become damaged (exposed wires, disconnection, etc.), purchase a new AC adaptor. Use of a damaged power cord may cause fire or electrical shock.
- Do not cut or damage the power cord. Also do not place heavy objects on top of it or subject it to excessive heat. Damage to the power cord may cause fire or electrical shock.
- Do not attempt to shape the power cord or subject it to excessive bending, twisting or pulling. This may cause fire or electrical shock.
- Please use the adaptor specified for this instrument. Use of another adaptor may cause fire, electrical shock, or malfunction.



Do not place containers containing water or other liquids on the instrument.

- Do not place the following objects on the instrument. Placing such objects on the instrument may cause fire or electrical shock if they spill and get inside the instrument.
 - Containers filled with water or other liquids (including vases, potted plants, cups, cosmetics and medicines)
 - Small metal objects (including hairpins, sewing needles and coins)
 - Flammable objects

In the event a foreign object should happen to get inside the instrument, please take the following actions:

1. Turn power off.
2. Unplug the AC adaptor from the wall outlet.
3. If there are any batteries loaded in the keyboard, remove them.
 - Do not touch the batteries directly with your hands when removing them. They may be hot or battery fluid may be leaking from them.
4. Consult with the dealer where you purchased the keyboard or with an authorized CASIO service provider.



Do not disassemble or modify the instrument.

- Never attempt to take apart or modify the instrument, its accessories, or separately sold options. Doing so may cause fire, electrical shock or malfunction. Consult your dealer concerning all inspection, adjustment or repair of internal components.



Do not use if there is an abnormality or malfunction.

- Do not use the instrument if there appear to be abnormalities such as the presence of smoke or abnormal odor. Also do not use the instrument if there appear to be malfunctions such as the power not coming on or sound not being produced. Use under such conditions may cause fire or electrical shock. In such cases, take the following actions immediately. Never attempt to repair the instrument yourself.
 1. Turn power off.
 2. Unplug the AC adaptor from the wall outlet.
 3. If there are any batteries loaded in the keyboard, remove them.
 - Do not touch the batteries directly with your hands when removing them. They may be hot or battery fluid may be leaking from them.
 4. Consult with the dealer where you purchased the keyboard or with an authorized CASIO service provider.



When the instrument has been dropped:

- In the case the instrument has been dropped or damaged, take the following actions. Continued use may cause fire or electrical shock.
 1. Turn power off.
 2. Unplug the AC adaptor from the wall outlet.
 3. If there are any batteries loaded in the keyboard, remove them.
 - Do not touch the batteries directly with your hands when removing them. They may be hot or battery fluid may be leaking from them.
 4. Consult with the dealer where you purchased the keyboard or with an authorized CASIO service provider.



Be careful of the bags around children.

- Never allow anyone to place the plastic bags of the instrument, its accessories, and its separately sold options over their heads. Doing so may cause suffocation. Particular caution is required in homes with small children.

CAUTION

AC Adaptor

- Do not locate the power cord in close proximity to heaters or other heating appliances. This may cause the cord to melt leading to possible fire or electrical shock.
- When unplugging the AC adaptor from an electrical outlet, always make sure to pull on the adaptor itself and not the cord. Pulling excessively on the cord may cause it to be damaged or break leading to possible fire or electrical shock.
- Do not touch the AC adaptor with wet hands when it is plugged in. This may cause electrical shock.
- When not using the instrument for an extended period such as when traveling, always make sure to unplug the AC adaptor from the electrical outlet for safety reasons.
- After use turn off the power switch of the instrument and unplug the AC adaptor from the electrical outlet.



Batteries

- Improper battery use may cause batteries to rupture and leak. This may cause injury, malfunction of the instrument or discoloration of furniture and other articles that come into contact with battery fluid. Take care to observe the following.
 - Install batteries so their polarity (+/-) matches that indicated on the instrument.
 - For safety and to prevent possible leakage of battery fluid, always make sure to remove batteries from the instrument when you do not plan to use it for a long time.
 - Always make sure that the batteries making up a set are all of the same type.
 - Never combine new batteries with old ones.
 - Never dispose of batteries by incinerating them. Never short or disassemble batteries, and do not expose them to excessive heat.
 - Replace dead batteries as soon as possible.
 - Never attempt to recharge batteries.

Transport

- When transporting the instrument, always make sure to unplug the AC adaptor from the electrical outlet and confirm that all other external connections have been disconnected. Only then should the instrument be transported. If the above is not done, the cord may be damaged leading to possible fire or electrical shock.



Care

- Whenever caring, make sure to first unplug the AC adaptor from the electrical outlet. Also remove the instrument's batteries if battery power is being used.



Location

- Never locate the instrument in areas subject to high humidity or heavy accumulation of dust. Doing so may cause fire or electrical shock.
- Never locate the instrument in areas subject to grease splatters or steam, such as in a kitchen or near a humidifier. Doing so may cause fire or electrical shock.



Do not place keyboard on lacquered furniture.

- The instrument's silicone rubber feet may eventually blacken or scar lacquered surfaces. Use felt cloth pads to insulate the feet or preferably use a CASIO musical instrument stand designed for your keyboard.

Do not get onto the instrument or stand.

- Do not crawl on top of the instrument or its optional stand. Particular caution is required in homes having small children. This may cause the instrument or stand to tip over and break resulting in injury.

Do not place heavy objects on the instrument.

- Do not place heavy objects on the instrument. This may cause the instrument to tip over or break resulting in injury.

Optional Stand (sold separately)

- Carefully assemble the stand following the assembly instructions that come with it. Securely tighten all bolts, nuts, and fasteners, and make sure that you mount the instrument correctly onto the stand. Incorrectly or insufficiently tightening screws, or incorrectly mounting the instrument onto the stand can cause the stand to tip over or the instrument to fall off the stand, possibly leading to injury.

Volume

- Very high volume levels can damage hearing. Avoid using the instrument at very high volume settings for long periods. Consult with a physician immediately if you experience impaired hearing or ringing in the ears.

Accessories and options

- Use only accessories that come with the instrument or authorized CASIO options (sold separately). Use of non-specified accessories or options may cause fire, electrical shock, or malfunction.

- You may not be able to see the keyboard keys light under direct sunlight or in other brightly lit areas.

Care of Your Keyboard

Avoid heat, humidity or direct sunlight.

Do not overexpose the instrument to direct sunlight, or place it near an air conditioner, or in any extremely hot place.

Take care not to drop the instrument and avoid strong impact.

Strong impact may cause malfunctions. When carrying or transporting the instrument, protect the keyboard and switches with soft cloth or other material.

Never attempt to modify any parts of the instrument.

Your keyboard is a precision electronic musical instrument. Any modification of, or tampering with parts may cause malfunction.

Do not use lacquer, thinner or similar chemicals for cleaning.

Clean the keyboard with a soft cloth dampened in a weak solution of water and a neutral detergent. Soak the cloth in the solution and squeeze until it is almost dry.

Contents

Safety Precautions	E-4
Care of Your Keyboard	E-7
Contents	E-8
Control Locations	E-10
Melody Guide Reference	E-12
Part 1 Before using the keyboard	E-14
About the power supply	E-14
Installing the batteries	E-14
Using AC power	E-15
Auto Power Off and Power On Alert	E-15
Auto Power Off (when using batteries)	E-15
Power On Alert (when using the AC adaptor)	E-16
To disable auto power off and power on alert	E-16
Part 2 Basic operations	E-17
To switch power on and off	E-17
To change tones	E-17
Keyboard split tones	E-18
Digital Sampling	E-19
Polyphony	E-19
Other Useful Functions	E-19
To change the key of the keyboard	E-19
To tune the keyboard	E-20
Playing the demo tunes	E-21
To start demo tune play	E-21
To stop demo tune play	E-21
Playing rhythms	E-22
To select and play a rhythm	E-22
Using auto-accompaniment	E-23
About the accompaniment keyboard	E-23
Using the CASIO CHORD system	E-24

To play a CASIO CHORD auto-accompaniment	E-25
Using standard fingerings	E-25
To play a FINGERED auto-accompaniment	E-26
Improvising with the preset patterns	E-27
Using fill-in rhythm	E-27
Using Synchro start	E-27
Part 3 Three Step Lesson System	E-28
Using Three Step Lesson System	E-28
Three Step Lesson System Tempo Setting	E-29
To play a built-in Song Bank tune	E-29
Using the Three Step Lesson System with Song Bank Tunes	E-30
How the Three Step Lesson System operates in Steps 1 through 3	E-31
Turning Off the Three Step Lesson System	E-32
Number of Simultaneously Lit Keys	E-32
To change the tone used for the melody of a Song Bank tune	E-32
Step 1: Easy Play	E-33
Step 2: Slow Play	E-33
Step 3: Normal Play	E-34
To practice the left hand part	E-35
To check if the right hand or left hand part is currently selected	E-35
Part 4 Technical Reference	E-36
Troubleshooting	E-36
Specifications	E-37
Part 5 Appendix	A-1
Fingered Chord Chart	A-1

Control Locations

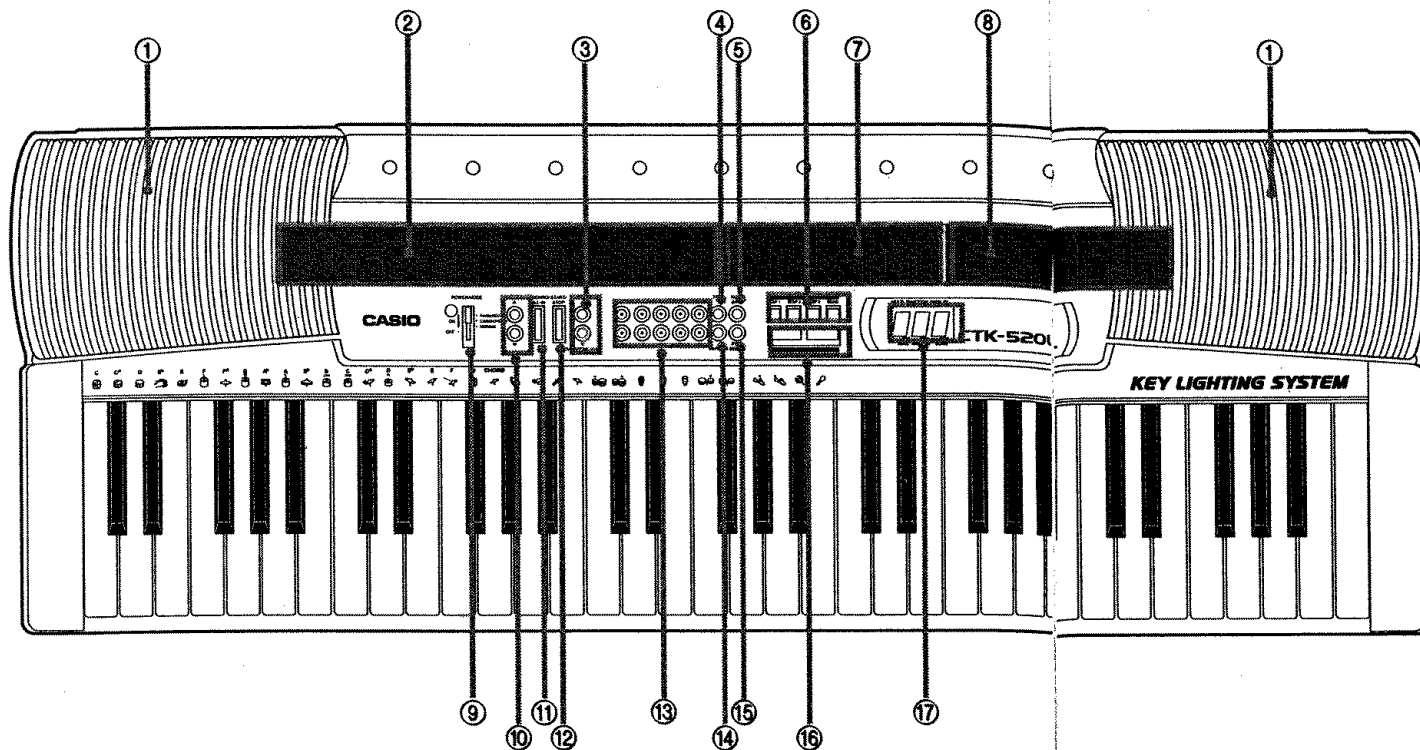

- | | |
|--------------------------------|--------------------------|
| ① Speakers | ⑨ POWER/MODE selector |
| ② 100 TONES list | ⑩ VOLUME buttons |
| ③ TEMPO/TRANSPOSE/TUNE buttons | ⑪ SYNCHRO/FILL-IN button |
| ④ TONE button | ⑫ START/STOP button |
| ⑤ SONG BANK button | ⑬ 0-9 buttons |
| ⑥ 3 STEP LESSON buttons | ⑭ RHYTHM button |
| ⑦ 50 RHYTHMS list | ⑮ PART SELECT button |
| ⑧ 40 SONG BANK list | ⑯ ONE KEY PLAY buttons |
| | ⑰ Display |

Note

- You may notice lines in the finish of the case of this keyboard. These lines are a result of the molding process used to shape the plastic of the case. They are not cracks or breaks in the plastic, and are no cause for concern.

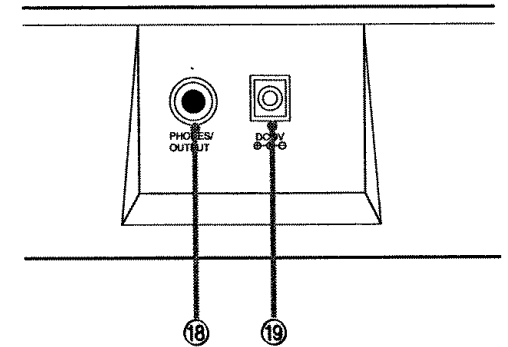

⑱ PHONES/OUTPUT jack

For connection of commercially available headphones. Output from the speakers is automatically cut when headphones are connected.

⑲ DC 9V jack

* Attachment of Score Stand

Insert both ends of the music stand provided with the CTK-520L into the two holes on the top surface.

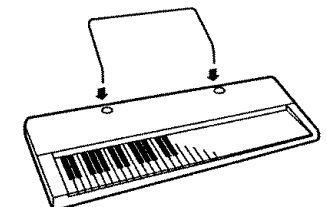

Melody Guide Reference

Melody guide uses the Three Step Lesson System to teach you how to play each of the 40 Song Bank tunes in three steps. The following is an overview of steps 1 and 2. See page E-28 for detailed explanations of these steps.

1
Set the POWER/MODE selector to NORMAL.

POWER/MODE
• FINGERED CASIO CHORD
• NORMAL
OFF

2
Press the SONG BANK button.

SONG BANK

SONG Indicator lights.

3
Find the song you want to play in the Song Bank list on the keyboard's console and input its song number.
• To select "Greensleeves" for example, use 0-9 buttons to input [0][7].

4
Press the STEP 1 or STEP 2 button.
• After a single beat, the keyboard stands and waits for you to play the first note.
• The keyboard key that corresponds to the first note of the tune you selected flashes.

5
Play the melody part on the keyboard.

<If you pressed the STEP 1 button in 4...>
Play the notes with the ONE KEY PLAY buttons.

- The accompaniment tempo automatically adjusts to play along with your melody.

<If you pressed the STEP 2 button in 4...>
Play the notes on the keyboard, pressing keys as they light.

- Keep the key depressed as long as it stays lit.
- If you selected any song from number 28 through 39, the lit key goes out as soon as you press it.
- The key that corresponds to the next note you need to play will flash.
- After you press the correct melody key, accompaniment proceeds to the next note.

Part 1 Before using the keyboard

Be sure to read the contents of this part of the manual before using the keyboard for the first time.

■ About the power supply

You can power your keyboard with 6 AA batteries, standard AC power (with an optional AC adaptor).

Installing the batteries

This keyboard can be powered by 6 AA size (SUM-3/R6P) dry cell batteries. Make sure that the unit is turned off when installing batteries.

1. Open the battery compartment cover on the bottom of the unit.
2. Load new batteries as illustrated, taking care that the plus (+) and minus (-) poles are facing in the correct directions.
3. Replace the battery compartment cover.

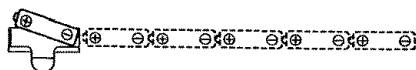

- Standard battery life: Approximately 1 hour (SUM-3/R6P).
Approximately 4 hours (AM3/LR6).

Important!

Promptly replace the batteries or use the AC adaptor when the following symptoms occur.

- Dim power supply indicator
- Abnormally low speaker/headphone volume
- Distortion of sound output
- A totally different tone may sound
- Abnormal rhythm pattern and demo tune play
- Continued sound output even after you release a button
- Occasional interruption of sound when playing at high volume
- Sudden power failure when playing at high volumes

Precautions

Incorrectly using batteries can cause them to leak or burst, and may damage your unit. Note the following precautions:

- Be sure that the plus (+) and minus (-) poles are facing in the correct directions.
- Do not mix battery types.
- Do not mix new batteries with old ones.
- Never leave dead batteries in the battery compartment.
- Remove batteries when not using the unit for extended periods.
- Never try to recharge the batteries that are specified for the power supply of this unit.

- Do not expose batteries to direct heat, let them become shorted or try to take them apart.
(If a battery leaks, clean out the battery compartment of the unit immediately, taking care to avoid letting the battery fluid come into direct contact with your skin.)

Using AC power

An AC adaptor (AD-5, optional) is required when using household current. Use only genuine CASIO adaptor with the same voltage rating (100, 120, 220, 230 or 240V) as the power supply in your area to prevent damage to internal components. Be sure to turn the power of the unit off before you connect the adaptor to the unit. Plug the AC adaptor into the AC outlet and the cord into the unit. This will automatically cut off the battery power supply.

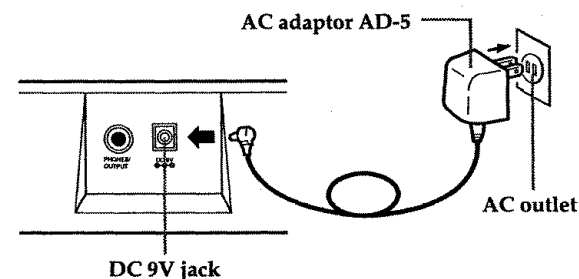

Note:

The shapes of the AC adaptor's plug and wall outlet differ in accordance with countries or regions. The illustration shows an example.

Important!

- The adaptor may become warm when it is being used. This is normal and does not indicate any problem.
- Be sure to unplug the adaptor from the power source when you are not using the unit.
- Whenever connecting or disconnecting the adaptor, be sure that the power of the unit is switched off.
- Never use a power supply that does not match that specified for the unit. Doing so can damage the adaptor or your unit.

■ Auto Power Off and Power On Alert

Auto Power Off (when using batteries)

The Auto Power Off function automatically switches power off if you do not perform any operation for about six minutes. When this happens, change the POWER/MODE selector position to OFF and then to NORMAL, CASIO CHORD, or FINGERED to turn power back on. You can also use the following operation to cancel the Auto Power Off function so that it does not switch power off.

Power On Alert (when using the AC adaptor)

If you leave power on without performing any operation for about six minutes, all of the keyboard keys light to alert you (no audible alarm sounds). Pressing any button or keyboard key returns to normal operation with the keyboard in its initial power on setting.

Notes

- The Auto Power Off function is invalid when the keyboard is powered by an AC adaptor.
- The power on alert does not function when the keyboard is being powered by batteries.

To disable auto power off and power on alert

While holding down the TONE button, turn keyboard power on. This disables the auto power off and power on alert until you turn power off and then back on again.

Part 2 Basic operations

This part of the manual provides you with the basic information you need to use your keyboard.

■ To switch power on and off



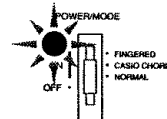

1. Set the POWER/MODE selector to NORMAL.



2. Press the keyboard keys.

3. The VOLUME up and down arrow buttons are used to adjust main volume.



- Pressing  or  displays the currently set volume setting. Press  or  again to change the volume setting.
- Volume can be adjusted over a range of 0 (minimum) to 9 (maximum).
- Volume is set to 7 when the power is turned on.
- A setting of 0 turns down the volume completely.
- The volume can be changed continuously by continuously pressing down the up or down buttons.
- Pressing the up and down buttons simultaneously sets the volume to level 7.
- Numeric values can be entered directly with the 0-9 buttons after the volume button has been pressed in step 3.
- The amount that the volume settings raises or lowers the volume level differs according to the tone, auto accompaniment, or song you are using.

4. To switch power off, set the POWER/MODE selector to OFF position.

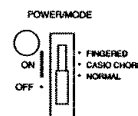

■ To change tones

1. Look at the tone list printed on the keyboard's console and find the one you want.
 - A total of 100 tones are available.
2. Press the TONE button.



- The number for the tone that is currently selected is shown on the display.

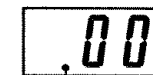

Tone Indicator

3. Use the 0-9 buttons to input the 2-digit number that identifies the tone you want to select.

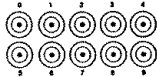

- Always enter two digits for the tone number. If you enter only one digit, the display will automatically return to the previous tone number setting after a few seconds.
- If you change the tone setting while a keyboard key is depressed, the tone does not change until you release the key and press a keyboard key again.
- With certain tones (such as percussion sounds and sound effects), there may be very little or no change at all in the pitch, no matter which keyboard key you press.
- You can specify tone numbers in the range of 00 to 99.
- If you input the wrong first digit for a tone number, you can return to the previous setting by pressing the TONE button.

TONE



Keyboard split tones

Some of the preset tones split the keyboard and assign two or more sounds. With such a preset tone, the sound produced depends on what position of the keyboard you play. For example, BASS/PIANO (tone 90) puts BASS on the left and PIANO on the right of the keyboard.

<Example>

BASS/PIANO (No.90)

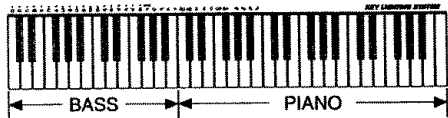

PERCUSSION (No.99)

- PERCUSSION (tone 99) assigns 35 percussion sound to the keyboard as illustrated below. The sound assigned to each key are indicated above the keyboard.



BASS DRUM	HIGH-MID TOM	HIGH BONGO
SIDE STICK	CRASH CYMBAL 1	LOW BONGO
ACOUSTIC SNARE	HIGH TOM	MUTE HIGH CONGA
HAND CLAP	RIDE CYMBAL 1	OPEN HIGH CONGA
ELECTRIC SNARE	CHINESE CYMBAL	LOW CONGA
LOW FLOOR TOM	RIDE BELL	HIGH TIMBALE
CLOSED HI-HAT	TAMBOURINE	LOW TIMBALE
HIGH FLOOR TOM	SPLASH CYMBAL	HIGH AGOGO
PEDAL HI-HAT	COWBELL	LOW AGOGO
LOW TOM	CRASH CYMBAL 2	CABASA
OPEN HI-HAT	CLAVES	MARACAS
LOW-MID TOM	RIDE CYMBAL 2	

- There are no sounds assigned to any keyboard keys from B4 onward when the "99 PERCUSSION" tone is selected.

Digital Sampling

A number of the tones that are available with this keyboard have been recorded and processed using a technique called digital sampling. To ensure a high level of tonal quality, samples are taken in the low, mid, and high ranges and then combined to provide you with sounds that are amazingly close to the originals. You may notice very slight differences in volume or sound quality for some tones when you play them at different positions on the keyboard. This is an unavoidable result of multiple sampling, and it is not a sign of malfunction.

Polyphony

The term polyphony refers to the maximum number of notes you can play at the same time. The CTK-520L has 12-note polyphony, which includes the notes you play as well as the rhythms and auto-accompaniment patterns that are played by the keyboard. This means that when a rhythm or auto-accompaniment pattern is being played by the keyboard, the number of notes (polyphony) available for keyboard play is reduced. Also note that some of the tones offer only 6-note polyphony.

- When rhythm or auto accompaniment is playing, the number of sounds simultaneously played is reduced.

Other Useful Functions

To change the key of the keyboard

The transpose feature of this keyboard lets you raise or lower its key in semitone increments. This means you can easily match to suit someone's voice, and you can eliminate sharps and flats from music making it easier to play.

1. While in any mode besides the Song Bank Mode (indicated by a dot in the first digit of the display), hold down the TONE button and press the RHYTHM button.



- Perform step 2 within five seconds after performing step 1.



2. Use the TRANSPOSE/TUNE buttons to change the key of the keyboard.

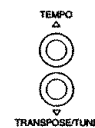

- Example: To change the tuning to B (indicated by -1 since it is one tone below C, which is the normal tuning of the keyboard).
- See page E-20 for the indicator that appears for each key.

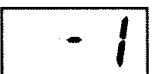

Indicator remains on the display for a few seconds.

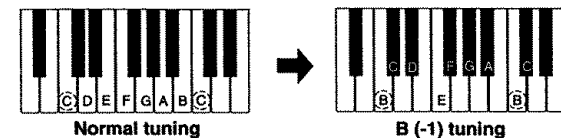

<Keys and their indicators>

Key: F# → G → A# → A → B# → B → C → C# → D → E# → E → F

Display: - 6 ◁ - 5 ▷ - 4 ◁ - 3 ▷ - 2 ◁ - 1 ▷ 0 ◁ 1 ▷ 2 ◁ 3 ▷ 4 ◁ 5



▶ : Pressing 

◁ : Pressing 

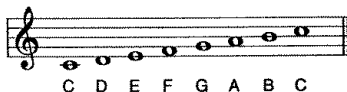
<Note Names>



Notes

- You cannot change the transpose setting while the keyboard is in the Song Bank Mode.
- In step 2 of the above operation, you could also use 0-9 buttons [0] to [5] to specify C through F.
- Pressing both of the TRANSPOSE/TUNE buttons ( / ) at the same time returns the transpose setting to C(0).
- The transpose setting is automatically set to C(0) whenever you turn keyboard power on.
- The transpose setting is automatically set to C(0) whenever you press the SONG BANK button.
- The pitch of a transposed note depends on the tone you are using. If the transpose operation causes a note to exceed its upper range, the same note from the lowest octave available is substituted.
- The transpose operation does not affect tone number 99 (PERCUSSION) or auto-accompaniment rhythms.
- Transposing tones 75 through 79 and 90 through 96 changes the range of keys to which each of the tones is assigned.
- The transpose setting is automatically set to C(0) whenever you press the DEMO button.

To tune the keyboard

A simple operation lets you tune the keyboard to another musical instrument.

- While in any mode besides the Song Bank Mode (indicated by a dot in the first digit of the display), hold down the TONE button and press the SONG BANK button.



- Perform step 2 within five seconds after performing step 1.

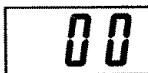

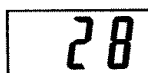
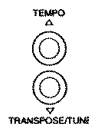

- Use the TRANSPOSE/TUNE buttons to change the tuning of the keyboard.



Indicator remains on the display for a few seconds.

Notes

- In step 2 of the above procedure, you could also use 0-9 buttons to input a value from 00 to 50.
- Pressing both of the TRANSPOSE/TUNE buttons ( / ) at the same time returns the tuning setting to 00.
- Pressing the SONG BANK button changes the tuning setting to 00.
- The tuning setting does not affect any of the 40 Song Bank tunes.
- You can tune the keyboard within a range of approximately ±50 cents (100 cents = 1 semitone).
- The tuning setting is automatically set to 00 whenever you turn the keyboard on.
- Pressing the DEMO button changes the tuning setting to 00.
- The tuning operation does not affect rhythm (percussion).

■ Playing the demo tunes

You can set up the keyboard to continually play its 40 built-in Song Bank tunes. Keyboard keys light to indicate the melody notes of the demo tune as it plays.

To start demo tune play

- Switch power on and adjust the volume level.

- Press the DEMO button.



- Demo tune play continues in a sequential endless loop until you switch it off.
- The number of the demo tune currently playing is shown on the display.
- You can play along on the keyboard while a demo tune is playing back.

- You can change the demo tune play being played by pressing 0-9 buttons.

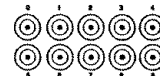

- The Song Bank tunes play back in tune number sequence, starting from the one you select.



To stop demo tune play

Press the DEMO button again to stop demo tune play.



Notes

Only the following buttons are enabled while a Song Bank tune is being played.

- VOLUME  / 
- 0-9 buttons
- START/STOP button
- POWER/MODE selector (OFF)
- DEMO button

- While holding down the TONE button, press the PART SELECT button (see "Turning Off the Three Step Lesson System" on page E-32).
- You cannot change the tone being used for the melody of a Song Bank tune.
- You can specify demo tune numbers from 00 to 39 only.

■ Playing rhythms

This keyboard features a collection of 50 exciting built-in rhythm patterns. Each pattern provides percussion back up for all your performances.

To select and play a rhythm

1. Set the POWER/MODE selector to NORMAL.

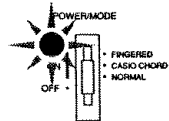

2. Look at the rhythm list printed on the keyboard's console and find the one you want.

3. Press the RHYTHM button.



- When you do, the rhythm indicator lights.
- The number that appears on the display indicates the currently selected rhythm.

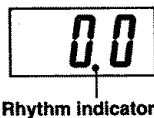

4. Use the 0-9 buttons pad to input the 2-digit rhythm number for the rhythm you want to use. To select "11 SLOW ROCK", for example, input 1, 1.

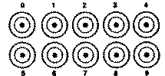

- Be sure to always specify a 2-digit number.
- You cannot specify numbers greater than 50.
- If you discover a mistake before you input the second digit, press the RHYTHM button to return to the previously set rhythm number.



5. Press the START/STOP button to start play of the rhythm.



- When you do, the selected rhythm starts to sound.

6. Use the TEMPO buttons to adjust the tempo of the rhythm.

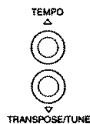

- Pressing ◐ or ◑ displays the currently set tempo setting. Press ◐ or ◑ again to change the tempo setting.
- When you press one of the TEMPO buttons, the tempo setting appears on the display. The value indicates the number of beats per minute. The display returns to normal shortly after you release the TEMPO button.
- Each time you press one of the TEMPO buttons while the tempo value is displayed, the tempo setting changes one step, within the range of 040 to 255.

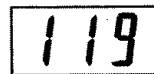

- Holding down either of the TEMPO buttons changes the tempo setting at high speed.
- To reset the tempo to the standard value of each rhythm, press both TEMPO buttons.
- Be sure to always specify a 3-digit number.
- Specifying a tempo below 040 or above 255 does not change the current setting.

7. Use the VOLUME buttons to adjust the volume of the rhythm.



8. To stop rhythm play, press the START/STOP button again.



■ Using auto-accompaniment

This keyboard features 50 accompaniment patterns that let you add full accompaniments to your performances automatically. With auto-accompaniment, part of the keyboard is reserved as an accompaniment keyboard. As you play your chords on the accompaniment keyboard, the accompaniment patterns adjust automatically to follow the progression you play.

You get a choice between two different methods for chord play. FINGERED lets you play chords as you normally do, while CASIO CHORD makes it possible to play fully formed chords with one finger.

About the accompaniment keyboard

The lower (left) 1.5 octaves are reserved for use as an accompaniment keyboard whenever you select CASIO CHORD or FINGERED with the POWER/MODE selector. The panel above the accompaniment keyboard keys is marked with the names of the notes they play. The remainder of the keyboard (the part that is not included in the accompaniment keyboard) is called the melody keyboard. Please be sure to remember these terms, because they will be used throughout the rest of this manual.

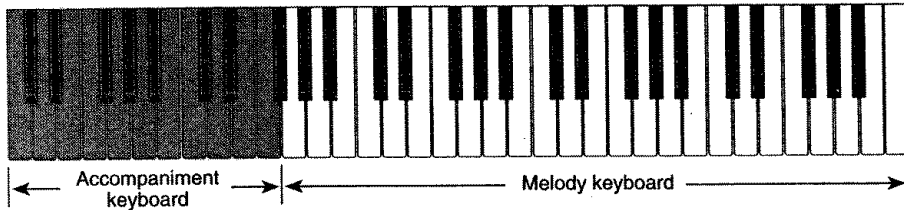

(The entire keyboard can be used for melody play while the POWER/MODE selector is set to NORMAL.)

Using the CASIO CHORD system

The CASIO CHORD system lets you easily play the four main types of chords. Play of chords is simplified as shown in the chart below.

Keys	Chord Type	Example
Pressing one accompaniment key	Major chord	C (C Major Chord)
Pressing two accompaniment keys	Minor chord	Cm (C Minor Chord)
Pressing three accompaniment keys	Seventh chord	C7 (C Seventh Chord)
Pressing four accompaniment keys	Minor seventh chord	Cm7 (C Minor Seventh Chord)

Note

- The bottom (leftmost) note that you play determines the name of the chord. If the bottom note is a C for example, the keyboard produces a C chord.

To play a CASIO CHORD auto-accompaniment

- Use the POWER/MODE selector to select CASIO CHORD.

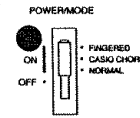

- Select an auto-rhythm as described under "To select and play a rhythm" on page E-22.

- Start play of the rhythm.



- If you want start play of the normal rhythm pattern, press START/STOP.
- You can also use synchro start (page E-27) to start rhythm play.

- Press either one or up to four keys on the accompaniment keyboard, and the corresponding accompaniment starts to play automatically.

- Continue pressing different keys on the accompaniment keyboard to play your chord progression.

- To stop auto-accompaniment play, press START/STOP again.

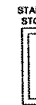

Using standard fingerings

The FINGERED mode lets you play a wider variety of chords. In this mode, you can start play of an accompaniment pattern by pressing three or four of the accompaniment keyboard keys.

This keyboard is capable of recognizing 15 different chords. The following shows the fingerings of these chords with a root of C. Note that you can omit the fifth notes (which are shown inside parentheses in the illustrations below) to produce 7, m7, maj7, add9 and mM7 chords.

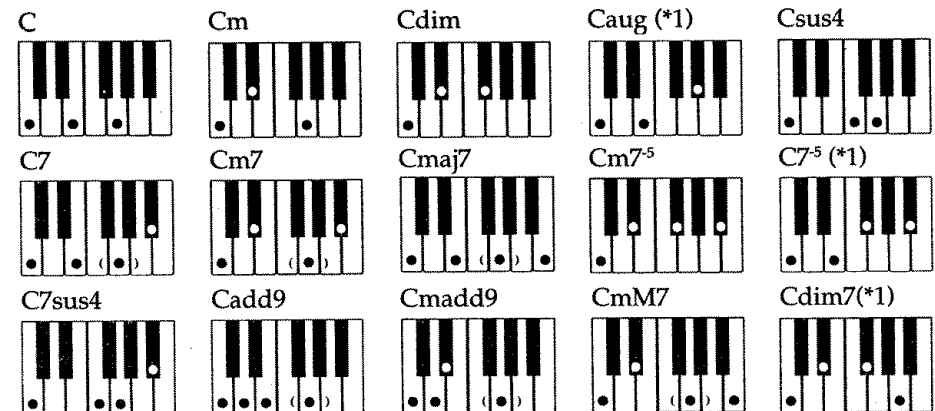

*1 With this chords, the lowest note in your fingering is always used as the root. Make sure that your fingering correctly identifies the root you want to use.

Important!

- If you play one or two notes only in the left hand, or three notes that do not make up a recognizable chord formation, no sound will be produced. FINGERED mode requires a conventional three or four-note chord formation to produce an auto-accompaniment. Also, note that auto-chords only work in conjunction with rhythm patterns, and not independently of them.

Notes

- The above examples show only one of the possible fingerings for each chord. Note that you can play the notes that form a chord in any combination. Each of the following fingerings for example, produces the same C chord.



- See the "Fingered Chord Charts" on page A-1 for information on the fingerings of chords for all roots.

To play a FINGERED auto-accompaniment

1. Use the POWER/MODE selector to select FINGERED.

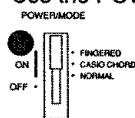

2. Select an auto-rhythm as described under "To select and play a rhythm" on page E-22.

3. Start play of the rhythm.

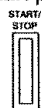

- If you want start play of the normal rhythm pattern, press START/STOP.
- You can also use synchro start (page E-27) to start rhythm play.

4. Play a chord on the accompaniment keyboard to start play of the auto-accompaniment.

5. Continue pressing keys on the accompaniment keyboard to play your chord progression.

6. To stop auto-accompaniment play, press START/STOP again.



Improving with the preset patterns

Pressing the START/STOP button to start rhythm play causes the normal version of the pattern to be played. You can also play a variation of the rhythm using the operation described below.

Using fill-in rhythm

You can insert a fill-in rhythm by pressing the SYNCHRO/FILL-IN button while an auto-rhythm plays.



Using Synchro start

You can start the rhythm and accompaniment pattern at the same time, with your play of the accompaniment keyboard. To do this, follow the steps below.

1. Set the POWER/MODE selector to the CASIO CHORD or FINGERED position.

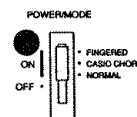

2. Select an auto-rhythm.

3. Press the SYNCHRO/FILL-IN button.

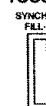

4. Press the accompaniment keys to play the first chord. As soon as you do, the auto-accompaniment pattern begins to play.



5. To stop the auto-accompaniment pattern play, press the START/STOP button.



Note

- If you set the POWER/MODE selector to NORMAL in step 1 on this page, the operation in step 4 starts play of the rhythm (percussion instruments) only.

Part 3 Three Step Lesson System

Using Three Step Lesson System

Even individuals who cannot play the keyboard at all can follow along with the 40 built-in Song Bank tunes with the ONE KEY PLAY buttons. You can also use the Three Step Lesson System to learn at your own pace. Play slowly at first until you are able to play along at normal speed.

Of the 40 built-in tunes, numbers 00 through 27 feature auto-accompaniment (auto-accompaniment tunes), while 28 through 39 are played using both hands (two-hand tunes).

Auto accompaniment tunes		Two-hand tunes	
Song Bank number	Tune name	Song Bank number	Tune name
00	WHEN YOU WISH UPON A STAR	28	FROM THE NEW WORLD
01	TWINKLE TWINKLE LITTLE STAR	29	MISTY
02	ACH DU LIEBER AUGUSTIN	30	MINUET (J.S.BACH)
03	AMAZING GRACE	31	CANON (PACHELBEL)
04	ODE TO JOY	32	SILENT NIGHT
05	LONDON BRIDGE	33	CLAIR DE LUNE
06	LONDONDERRY AIR	34	ETUDE op.10, no.3 "CHANSON DE L'ADIEU"
07	GREENSLEEVES	35	THE ENTERTAINER
08	AULD LANG SYNE	36	MOON RIVER
09	JOY TO THE WORLD	37	FUR ELISE
10	JINGLE BELLS	38	TURKISH MARCH (RONDO ALLA TURCA)
11	OVER THE RAINBOW	39	INVENTION no.1
12	O CHRISTMAS TREE		
13	YANKEE DOODLE		
14	SANTA LUCIA		
15	WHEN THE SAINTS GO MARCHING IN		
16	ALOHA OE		
17	SPRING FROM "THE FOUR SEASONS"		
18	STAND BY ME		
19	YOU CAN'T HURRY LOVE		
20	IMAGINE		
21	I JUST CALLED TO SAY I LOVE YOU		
22	LITTLE BROWN JUG		
23	MARCH FROM "THE NUTCRACKER"		
24	THE ENTERTAINER		
25	SERENADE "EINE KLEINE NACHTMUSIK"		
26	THE GIRL FROM IPANEMA		
27	LOVE STORY		

The Three Step Lesson System can be used with the following three-step lesson plan to master keyboard play.

Step 1: Easy Play

Pressing the ONE KEY PLAY buttons plays the melody for an auto-accompaniment tune or the right hand part for two-hand tunes. In both cases, the auto-accompaniment (the right hand part in the case of two-hand tunes) is played automatically by the keyboard. In place of the ONE KEY PLAY buttons, you can also press any key of the keyboard to play the melody or right hand part. The purpose of this step is to familiarize yourself with the timing required to play melody notes.

Step 2: Slow Play

Press the keys that light as they teach you the correct notes to play. You can play at the pace you want, because the auto-accompaniment or left hand part waits until you press the correct key.

Step 3: Normal Play

At this level, the keyboard's keys still light to indicate which notes to play, but they no longer wait for you to press the correct key. The auto-accompaniment or left hand part is played at normal speed.

Notes

- You may not be able to see the keyboard keys light under direct sunlight or in other brightly lit areas.
- You can press the ONE KEY PLAY, STEP 1, STEP 2, and STEP 3 buttons at any time, except while a demo tune is playing. To return the keyboard to its normal mode, press the SONG BANK button.

Three Step Lesson System Tempo Setting

You can use the procedure in step 6 of the procedure on page E-22 to set the tempo of the left-hand part for Song Bank and Three Step Lesson System play (Step 1 through 3).

This means you can use a slower tempo at the beginning, and then increase it as you learn. Press both of the TEMPO buttons (⊙ and ⊙) at the same time to return the tempo to its initial preset setting.

To play a built-in Song Bank tune

- Look up the number of the tune you want to play in the song book list.
- Press the SONG BANK button until the Song Bank indicator lights.



Indicates Song Bank number.
The number that appears is the currently selected Song Bank number.

3. Input the two digit number for the song you want to play.

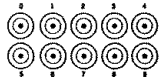

• Example: 18 "Stand By Me"

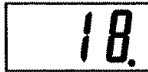

4. Press the START/STOP button to start play of the selected song.



• The song you select plays repeatedly, with the keyboard keys lighting to indicate the melody notes.

5. To stop Song Bank tune play, press the START/STOP button again.



6. To exit the SONG Mode, press the SONG BANK button again.



• At this time the tone number or rhythm number appears on the display.

Notes

- Always enter two digits for the Song Bank number.
- You can input Song Bank tune numbers in the range of 00 to 39.
- You can input a Song Bank tune number even while another Song Bank tune is playing.
- If you input the wrong first digit for a Song Bank tune number, you can return to the previous setting by pressing the SONG BANK button.
- The RHYTHM button is disabled in the Song Bank Mode. If you want to play a rhythm, press the SONG BANK button to return to the normal mode first.

Using the Three Step Lesson System with Song Bank Tunes

When you use a Song Bank Tune with melody guide, the Three Step Lesson System teaches you which melody notes to play.

Auto-accompaniment Song Bank Tune

Chord and melody part keys light.



Chord
The root (the C-note of a C-chord) and other notes that make up the chord alternately light.

Melody note lights.

Note

- Some Song Bank tunes use chords (such as C6) that cannot be played with the Fingered setting (page E-25). Though you will be able to play these chords in the Song Bank mode by pressing the keyboard keys that light, you will not be able to play these chords by using the same fingering in the Fingered Mode.

Two-hand Song Bank Tune

Left hand and right hand part keys light.

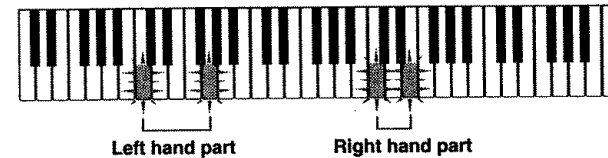

How the Three Step Lesson System operates in Steps 1 through 3

When using an auto-accompaniment Song Bank tune with the Three Step Lesson System, the lights indicate not only the note you should play, but how long you should play it (how long you should keep the key depressed). The following describes what illumination of keys indicates.

- **Note Guide:** A lit key indicates the note to be played.
- **Length Guide:** Key remains lit for as long as note should be played.
- **Next Note Guide:** A flashing key indicates the next note to be played.
- **Consecutive Note Guide:** When a key lights, goes out momentarily, and then lights again, it indicates that the same note should be played in succession.

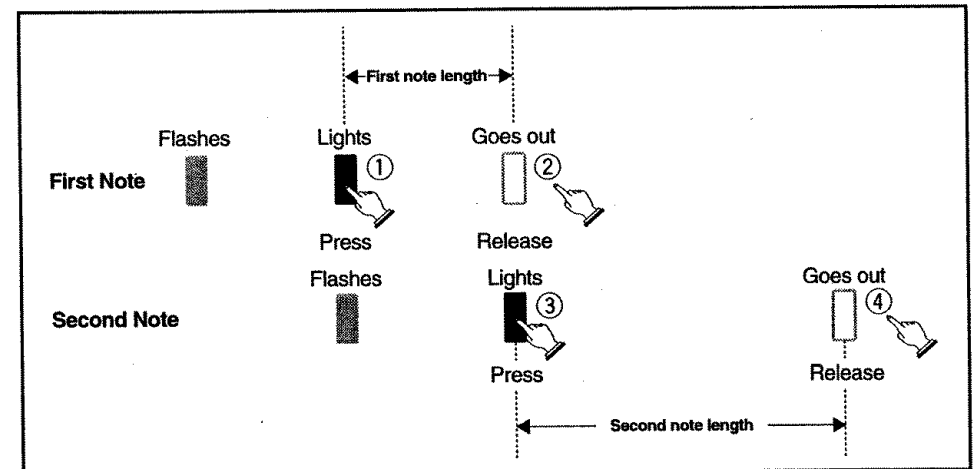

Note lengths are not indicated by the Three Step Lesson System when playing a two-hand tune with Step 1 and Step 2. The lit key goes out as soon as you press the correct keyboard key and the next note's key flashes.

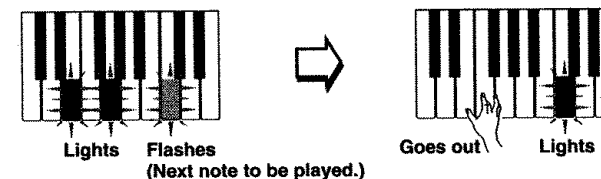

Turning Off the Three Step Lesson System

1. While holding down the TONE button, press the PART SELECT button.



- Repeat the above to turn the Three Step Lesson System back on.

Note

- The Three Step Lesson System turns back on when you start demo tune play, when you press the SONG BANK button in the normal mode (pages E-29~E-30 steps 1 to 3), or after the power on alert function (page E-16) operates.

Number of Simultaneously Lit Keys

The keyboard can play up to four notes at the same time. All four keys light when pressed while the Three Step Lesson System is turned on.

To change the tone used for the melody of a Song Bank tune

1. Following step 3 of the procedure on page E-30, press the TONE button.



- Both the Song Bank indicator and Tone indicator appear on the display, along with the tone number of the tone that is currently assigned to the keyboard.

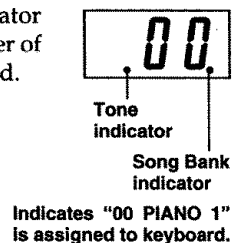

2. Input a value to select the tone you want to use.

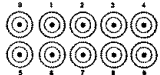

- Example: 30 Violin

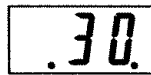

Notes

- You cannot change the tone of the two-hand Song Bank tunes (number 28 through 39).
- Selecting another Song Bank tune switches the tone setting to the newly selected tune's preset melody tone.
- The tone assigned to the keyboard is the same one specified for the melody of the Song Bank tune.
- The above procedure can be used to change the Song Bank melody tone before starting play or while play is already in progress.

Step 1: Easy Play

You can press the ONE KEY PLAY buttons or any of the keyboard keys to play along with the melody (right hand part) of the Song Bank tune. You do not have to worry about pressing the right key, so you can concentrate on getting the timing right.

1. Press the STEP 1 button.



- You will hear a single beat, and then the keyboard stands by waiting for you to play the first note. If the tune includes intro measures, the keyboard enters standby after the intro measures are complete.

2. Press the ONE KEY PLAY buttons to play each note of the tune.



- The accompaniment (left hand) part of the tune follows along as you play the melody (right hand) part.
- The keyboard key that corresponds to the next note to be played flashes, and lights when you play the note.
- The rhythm (percussion) part does not sound.
- Play of the accompaniment (left hand part) ends when you play the last note of the tune or after the ending measures of the tune are played, and then re-starts from the beginning.

3. Try pressing any one of the keyboard keys in place of the ONE KEY PLAY buttons.

- Pressing any keyboard key plays the correct melody (right hand part) note.
- Pressing more than one (up to four) keyboard keys plays the corresponding number of melody notes.

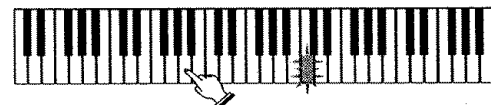

The correct note is played even if you do not press the key that is lit.

4. To interrupt an Easy Play session, press the START/STOP button.



Step 2: Slow Play

With Slow Play, you have to play the note that the Three Step Lesson System indicates. But don't worry - the accompaniment (left hand part) waits until you can play the correct note before continuing. This means you can take your time and play at your own pace.

1. Press the STEP 2 button.



- After a count beat, the keyboard stands by waiting for you to play the first note. If the tune includes intro measures, the keyboard enters standby after the intro measures are complete.

2. Play the notes indicated by the Three Step Lesson System.

- The accompaniment (left hand) part of the tune follows along as you play the melody (right hand) part.
- The keyboard key that corresponds to the next note to be played flashes, and lights when you play the note.
- The rhythm (percussion) part does not sound.
- Play of the accompaniment (left hand part) ends when you play the last note of the tune or after the ending measures of the tune are played, and then re-starts from the beginning.



Press keyboard keys as they light. More than one key may light when you are playing a two-hand tune. Press all keys that light.

3. To interrupt an Slow Play session, press the START/STOP button.



Step 3: Normal Play

Normal Play also shows you which notes to play, but unlike Slow Play, it does not wait for you to press the key. The accompaniment part is played at normal speed, no matter what you play (or don't play) on the keyboard.

1. Press the STEP 3 button.



- Play starts after a count beat.

2. Play along on the keyboard, following the keys as they light.

- The accompaniment (left hand) part of the tune plays at normal speed, regardless of what you play on the keyboard.
- The keyboard key that corresponds to the next note to be played flashes, and lights when the note should be played.

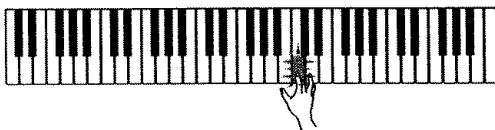

3. To interrupt a Normal Play session, press the START/STOP button.



To practice the left hand part

Once you master melody (right hand) part play, you can use the two-hand tunes (numbers 28 through 39) to practice the accompaniment (left hand) part.

1. Press the STEP 1, STEP 2, or STEP 3 button.

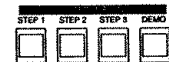

- Playback returns to the beginning of the song, and after a count beat the melody (right hand) part starts to play with the Three Step Lesson System indicating how to play the accompaniment (left hand) part.

2. Press the PART SELECT button to switch the left hand play.



3. To interrupt play of the melody, press the START/STOP button.



4. Press the PART SELECT button to return the part selection to its previous setting.



Notes

- The Three Step Lesson System indicating how to play the melody (right hand) part immediately after you select one of the two-hand tunes (numbers 28 through 39).
- The PART SELECT buttons are operational only while STEP 1, STEP 2, or STEP 3 is playing or paused (by the START/STOP button).

To check if the right hand or left hand part is currently selected

The Three Step Lesson System tells you what part is currently selected whenever you press the STEP 1, STEP 2 or STEP 3 button. Pressing either of these buttons causes the leftmost three keys to light when the left hand part is selected, and the rightmost three keys to light when the right hand part is selected.



Left hand part selected

Right hand part selected

Part 4 Technical Reference

■ Troubleshooting

Be sure to check the following table whenever you experience problems with keyboard operation.

Symptom	Cause	Action
<ul style="list-style-type: none"> No sound when keyboard keys are pressed. 	<ul style="list-style-type: none"> Tone "99 PERCUSSION" is selected and you are pressing keys that are not assigned tones. 	<ul style="list-style-type: none"> While "99 PERCUSSION" is selected, you can use only keys to the left of B⁴. These keys are marked on the console with illustrations of percussion instruments.
<ul style="list-style-type: none"> Keyboard keys remain lit. 	<ul style="list-style-type: none"> Keyboard is standing by for keyboard play in STEP 2. 	<ul style="list-style-type: none"> Press the lit keys and continue with STEP 2 play. Press the START/STOP button to stop STEP 2.
<ul style="list-style-type: none"> Keyboard keys light but no sound is produced. 	<ul style="list-style-type: none"> Power on alert is telling you that power is left on. 	<ul style="list-style-type: none"> Press any button or keyboard key to resume normal operation with the keyboard in its initial power on setting.
<ul style="list-style-type: none"> RHYTHM button does not work. 	<ul style="list-style-type: none"> Keyboard is in the Song Bank Mode. 	<ul style="list-style-type: none"> Press the SONG BANK button to return to the Normal Mode.
<ul style="list-style-type: none"> Song Bank tone does not change. 	<ul style="list-style-type: none"> A two-hand Song Bank tune (number 28 through 30) is selected. 	<ul style="list-style-type: none"> Change to an auto accompaniment Song Bank tune (number 00 to 27). You cannot change the tone setting of a two-hand Song Bank tune (number 28 through 39).
<ul style="list-style-type: none"> Cannot change TRANSPOSE/TUNE settings. 	<ul style="list-style-type: none"> Keyboard is in the Song Bank Mode. Demo tune play is in progress. 	<ul style="list-style-type: none"> Press the SONG BANK button to return to the Normal Mode. Stop demo tune play.
<ul style="list-style-type: none"> Cannot play correctly even when the lit keyboard keys are pressed with STEP 1. 	<ul style="list-style-type: none"> More than one key is being pressed at the same time, which causes accompaniment to advance the corresponding number of notes (up to four). 	<ul style="list-style-type: none"> When using STEP 1, press keyboard keys one by one.

■ Specifications

Model:	CTK-520L
Keyboard:	61 standard-size keys; 5 octaves
Tones:	100 presets
Polyphony:	12 - note (max.)
Three Step Lesson System:	Number of simultaneously lit keys; 4 Three steps Playback: 1 tune repeat playback
Auto-accompaniment:	Rhythm patterns 50 presets Tempo Adjustable, 216 steps (40 ~ 255), initial value: 120 Chords Two systems: CASIO CHORD, FINGERED Other Fill-in pattern, Synchro start
Song Bank tunes:	40 tunes
Other Functions:	Transpose (F [#] ~C~F: half-note) Tuning Adjustable A4 = Approx.440 Hz, ±50 cents, initial value: A4 = Approx.440 Hz
Speakers:	10 cm diameter x 2 (Output: 2W+2W)
Digital Volume Control:	Main volume; 10 steps (0 ~ 9), initial value: 7
I/O Terminals:	Power Supply DC 9V jack Headphones/Output Stereo standard jack [output impedance: 50 Ω, output voltage: 2V (RMS) MAX],
Power Supply:	2-way AC/DC power sources; Batteries 6 AA-size Battery life approximately 1 hour on R6P (SUM-3) manganese batteries/4hours on LR6 (AM3) alkaline batteries AC Required optional AD-5 AC adaptor
Auto Power Off:	Approximately 6 minutes after the last operation (Operates during battery use only)
Power Consumption:	9 V --- 7.7 W
Dimensions:	924 x 325 x 89 mm (36 7/16" x 12 13/16" x 3 1/2")
Weight:	4.35 kg (9.6 lbs) excluding batteries

* Designs and specifications are subject to change without notice.

Part 5 Appendix/Apéndice

■ Fingered Chord Charts

■ Cuadros de acordes digitados

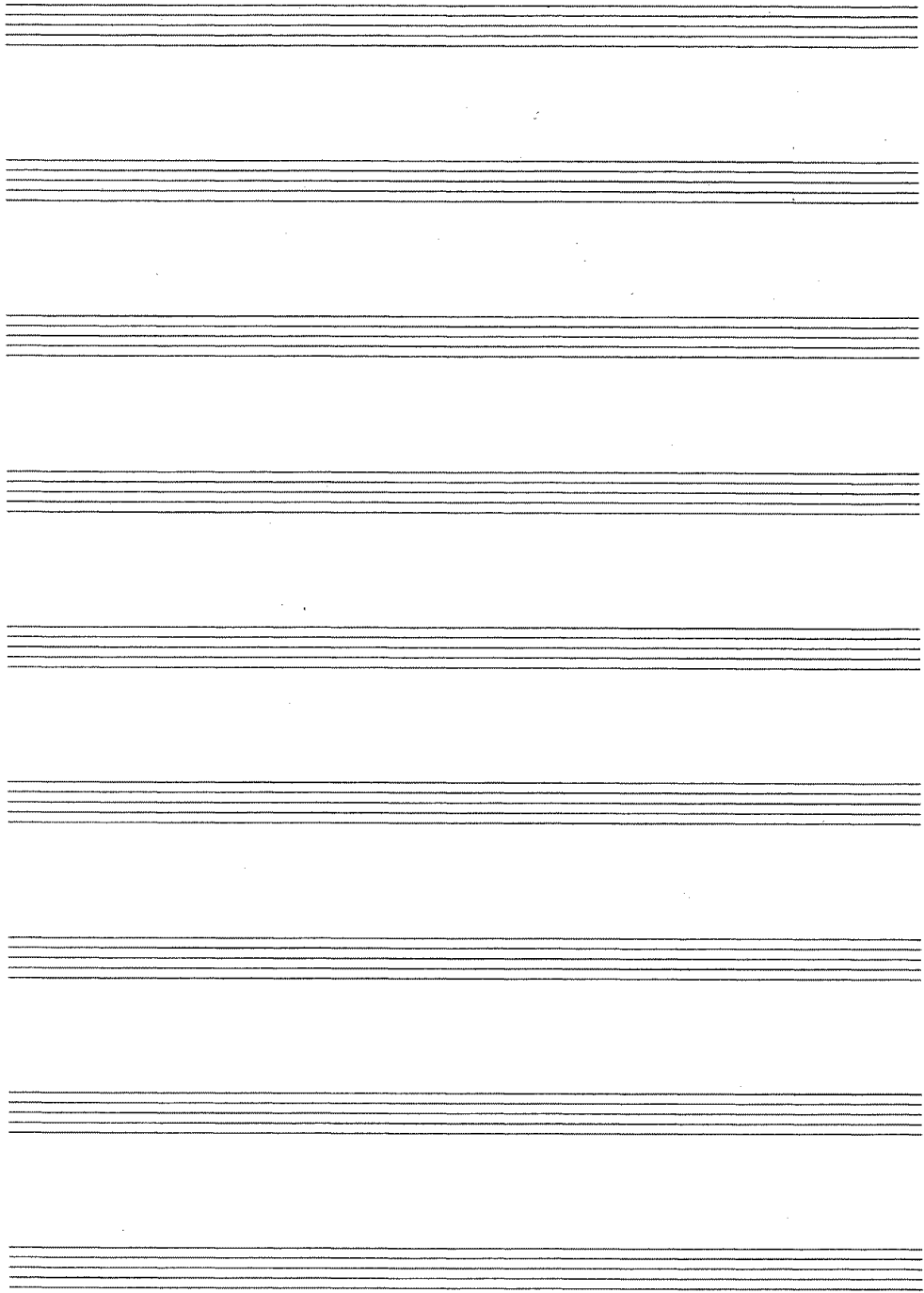

Chord Type Root	M	m	7	m7	dim7
C					
C#/(D♭)					
D					
(D#)/E♭					
E					
F					
F#/(G♭)					
G					
(G#)/A♭					
A					
(A#)/B♭					
B					

Chord Type Root	M7	m7-5	dim	aug	sus4
C					
C#/(D♭)					
D					
(D#)/E♭					
E					
F					
F#/(G♭)					
G					
(G#)/A♭					
A					
(A#)/B♭					
B					

- Cannot be specified in FINGERED setting because of accompaniment keyboard limitations, but augmented chords made up of the same component notes (with different base note) can be used instead.

Chords with same component notes as B[♭] aug.....D aug, F[♯] aug

Chords with same component notes as B aug.....E[♭] aug, G aug

Chord Type Root	7sus4	m add9	mM7	7-5	add9
C					
C#/(D♭)					
D					
(D#)/E♭					
E					
F					
F#/(G♭)					
G					
(G#)/A♭					
A					
(A#)/B♭					
B					

- No puede especificarse en el ajuste FINGERED debido a las limitaciones del teclado de acompañamiento, pero en su lugar pueden usarse los acordes aumentados compuestos por las mismas notas componentes (con diferente nota básica).

Acordes con las mismas notas componentes como B[♭] aumentada ... D aumentada, F[♯] aumentada.

Acordes con las mismas notas componentes como B aumentada ... E[♭] aumentada, G aumentada.



This recycle mark indicates that the packaging conforms to the environmental protection legislation in Germany.

Esta marca de reciclaje indica que el empaquetado se ajusta a la legislación de protección ambiental en Alemania.

CASIO.

CASIO COMPUTER CO.,LTD.
6-1, Nishi-Shinjuku 2-chome
Shinjuku-ku, Tokyo 163-02, Japan

MA9610-B (英) (西) Printed in Malaysia
CTK520LES-1
4154-920-0-12

P