

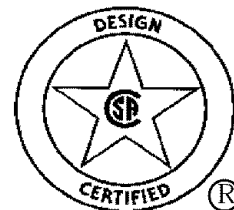

Gas-Fired Vented FLOOR FURNACE

P/N 74521
REV. 08/97

INSTALLATION AND OPERATING INSTRUCTIONS



MODEL NUMBERS

MILLIVOLT CONTROL SYSTEM				
NATURAL GAS	90N30A	90N50A	90N65A	90N75A

WARNING: If the information in this manual is not followed exactly, a fire or explosion may result causing property damage, personal injury or loss of life.

- Do not store or use gasoline or other flammable vapors and liquids in the vicinity of this or any other appliance.

- WHAT TO DO IF YOU SMELL GAS:

- Do not try to light any appliance.
- Do not touch any electrical switch; do not use any phone in your building.
- Immediately call your gas supplier from a neighbor's phone. Follow the gas supplier's instructions.
- If you cannot reach your gas supplier, call the fire department.

- INSTALLATION AND SERVICE MUST BE PERFORMED BY A QUALIFIED INSTALLER, SERVICE AGENCY OR THE GAS SUPPLIER.

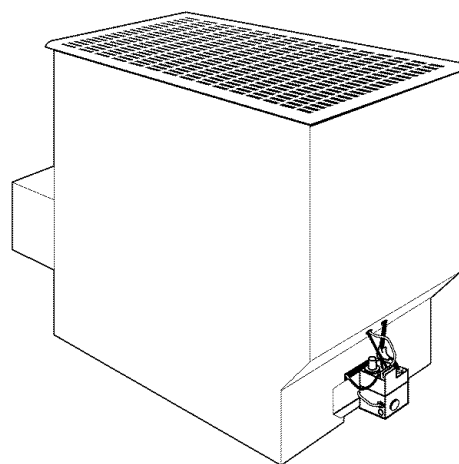

The coating selected to provide longer life to the heat exchanger may smoke slightly upon initial firing. Please provide adequate ventilation if this occurs.

WARNING: Operation of this furnace when not connected to a properly installed and maintained venting system can result in Carbon Monoxide (C.O.) poisoning and possible death. For your safety, this furnace and the venting system should be inspected at least annually by a qualified service person.

THIS UNIT IS NOT APPROVED FOR INSTALLATION IN MOBILE HOMES, GREENHOUSES, OR ENVIRONMENTS INVOLVING DUSTY, WET, CORROSIVE, OR EXPLOSIVE CONDITIONS. SUCH CONDITIONS WILL INVALIDATE THE WARRANTY AND MAY CREATE UNSAFE CONDITIONS.

CONTENTS:

Introduction.....	2	Checking the Gas Piping.....	9
Specifications	2	Thermostat Installation.....	10
Safety Rules.....	2	Lighting.....	11
Helpful Installation Information.....	3	To Turn Off Gas.....	11
Installation Requirements.....	3	Adjusting the Pilot Flame.....	12
Furnace Location.....	4	Orifice Charts.....	12
Fresh Air for Combustion & Venting.....	4	Adjusting the Main Burner.....	12
Cutting the Floor Opening.....	5	Optional Operation.....	13
Setting the Floor Furnace.....	5	Maintenance.....	14
Installing the Draft Hood.....	6	Trouble Shooting.....	15
Connecting the Vent.....	6	Repair Parts.....	16
Gas Supply and Piping.....	8	Warranty.....	18

INTRODUCTION

THIS IS A GAS-FIRED, GRAVITY VENTED FLOOR FURNACE THAT WILL OPERATE SAFELY AND PROVIDE AN EFFICIENT SOURCE OF HEAT WHEN INSTALLED, OPERATED AND MAINTAINED AS RECOMMENDED IN THESE INSTALLATION AND OPERATING INSTRUCTIONS. READ THESE INSTRUCTIONS THOROUGHLY BEFORE INSTALLING, SERVICING, OR USING THE APPLIANCE. IF YOU DO NOT UNDERSTAND ANY PART OF THESE INSTRUCTIONS, CONSULT LOCAL AUTHORITIES, OTHER QUALIFIED INSTALLERS, SERVICE AGENCIES, THE GAS SUPPLIER OR THE MANUFACTURER.

FLOOR FURNACE SPECIFICATIONS

Your floor furnace and draffhood are packed together in one master carton. The carton containing the floor furnace also contains the thermostat, thermostat wire, insulated staples, furnace key and lighter rod. The draffhood is packed in its own carton within the master pack and contains screws and rope-like gasket material for attaching and sealing the draff hood to the floor furnace. Check the model numbers on the two cartons to be sure they match.

MODEL NUMBER – NAT. GAS	90N30A	90N50A	90N65A	90N75A
Hourly BTU Input	30,000	50,000	62,000	75,000
Width and Length	14"x32"	22"x32"	24"x38"	26"x42"
Overall Height	29-1/4"	29-1/4"	29-7/8"	30-7/8"
Overall Grille Size	16"x34-1/8"	24"x34"	26"x40"	28"x44"
Size of Floor Opening	14 1/4"x32 1/4"	22 1/2"x32 1/2"	24 1/2"x38 1/2"	26 1/2"x42 1/2"
Gas Pipe Size at Furnace	1/2"	1/2"	1/2"	1/2"
Vent Pipe Size	4"	4"	5"	5"
Floor to Center Line of Vent	22"	22"	22"	22"

SAFETY RULES

1. **WARNING: IMPROPER INSTALLATION, ADJUSTMENT, ALTERATION, SERVICE OR MAINTENANCE CAN CAUSE PROPERTY DAMAGE, PERSONAL INJURY OR LOSS OF LIFE. INSTALLATION AND SERVICE MUST BE PERFORMED BY A QUALIFIED INSTALLER, SERVICE AGENCY OR THE GAS SUPPLIER. KEEP BURNER AND CONTROL COMPARTMENT CLEAN. SEE INSTALLATION AND OPERATING INSTRUCTIONS ACCOMPANYING APPLIANCE. DUE TO HIGH SURFACE TEMPERATURES KEEP CHILDREN, CLOTHING AND FURNITURE AWAY.**

SAFETY RULES - Continued

2. FOLLOW ALL APPLICABLE CODES AND ORDINANCES. IF THERE ARE NONE, FOLLOW THE INSTALLATION STANDARDS, LATEST EDITION OF NFPA54/ANSI.Z223.1. A COPY MAY BE OBTAINED FROM THE AMERICAN GAS ASSOCIATION, 1515 WILSON BLVD., ARLINGTON, VA. 22209, OR THE NATIONAL FIRE PROTECTION ASSOCIATION, BATTERY MARCH PARK, QUINCY, MA. 02269.
3. DO NOT INSTALL THIS FLOOR FURNACE IN A RECREATIONAL VEHICLE, TRAILER OR MOBILE HOME.
4. DO NOT OPERATE THIS FLOOR FURNACE UNLESS IT IS CONNECTED TO A PROPERLY INSTALLED AND MAINTAINED VENT SYSTEM. DO NOT EXHAUST FLUE GASES UNDER THE FLOOR FOR ANY REASON.
5. BE SURE THIS FLOOR FURNACE IS EQUIPPED FOR THE TYPE GAS YOU INTEND TO USE.
6. LOCATE THE THERMOSTAT IN A ROOM OR SPACE THAT CANNOT BE SEPARATED BY A DOOR OR OTHER MEANS FROM THE ROOM OR SPACE IN WHICH THE FLOOR FURNACE GRILL IS INSTALLED.
7. NEVER USE A MATCH, CANDLE, FLAME OR OTHER SOURCE OF IGNITION TO CHECK FOR GAS LEAKS. USE ONLY SOAPY WATER OR LIQUID DETERGENT.
8. ADEQUATE AIR FOR COMBUSTION AND VENTING MUST BE PROVIDED.
9. IF IT IS SUSPECTED THAT RISING WATER OR SEEPAGE MAY ENTER THE FLOOR FURNACE, TURN OFF THE GAS IMMEDIATELY. DO NOT USE THIS FLOOR FURNACE IF ANY PART HAS BEEN UNDER WATER. IMMEDIATELY CALL A QUALIFIED SERVICE TECHNICIAN TO INSPECT THE FLOOR FURNACE AND TO REPLACE ANY PART OF THE CONTROL SYSTEM AND ANY GAS CONTROL WHICH HAS BEEN UNDER WATER.
10. HAVE YOUR FLOOR FURNACE AND VENT SYSTEM INSPECTED AT LEAST ANNUALLY BY A QUALIFIED SERVICE TECHNICIAN.
11. THE GRILL BECOMES HOT WHEN THE FLOOR FURNACE IS IN OPERATION. CHILDREN MUST BE CLOSELY SUPERVISED WHEN IN THE PRESENCE OF ANY HEATING APPLIANCE. CONTACT WITH BARE SKIN MAY RESULT IN SEVERE BURNS. KEEP CHILDREN OFF THE GRILL.
12. BEFORE CLEANING OR SERVICING THE FLOOR FURNACE, TURN OFF THE GAS AND ALLOW IT TO COOL. THIS WILL PREVENT BURNS.
13. ALWAYS LEAVE THE GRILL IN PLACE EXCEPT WHEN CLEANING OR SERVICING THE FLOOR FURNACE.
14. NEVER OPERATE THE FLOOR FURNACE WITHOUT THE SIGHT GLASS ASSEMBLY IN PLACE, OR WITH THE GLASS BROKEN OR MISSING.

HELPFUL INSTALLATION INFORMATION

Do not attempt to heat through more than one doorway in any direction to adjoining rooms.

Always over-estimate the amount of heat required rather than under-estimate it. Always use the next size floor furnace above your actual heating requirements.

Seal all cracks around windows, doors, and attic access doors or significant heat loss will occur.

INSTALLATION REQUIREMENTS

Listed below are steps that are part of a floor furnace installation. You must see that each step is followed closely so that the floor furnace will provide maximum efficiency with safe operation.

YOU MUST:

1. Locate the floor furnace in the best available space for safe and efficient operation.
2. Provide fresh air for combustion and venting.
3. Cut and frame the floor opening so that the floor furnace fits properly.
4. Attach the draft hood and connect the vent pipe in compliance with applicable codes.
5. Connect an adequate gas supply to the floor furnace.
6. Select the best location for the thermostat.
7. Check and adjust the floor furnace for safe and efficient operation.

If you have any doubts about the correct way to install a floor furnace, contact local authorities or agency, or your gas supplier. If local or state codes require that your floor furnace installation be inspected by local authorities, do so after the floor furnace is installed and before it is put into service.

FLOOR FURNACE LOCATION

Choose a central location such as a hallway but where occupant traffic is minimal and where there is at least 18 inches of room from two adjoining sides of the grill to the nearest wall so that occupants may pass without stepping on the grill. See Figure Number 1.

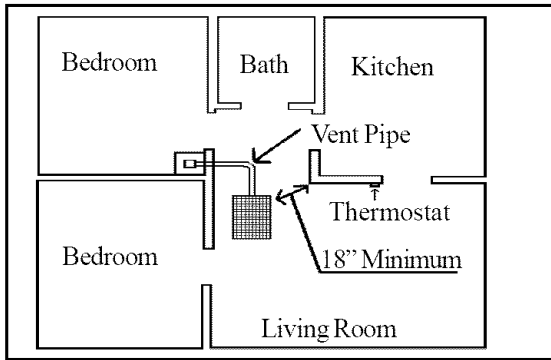

FIGURE 1

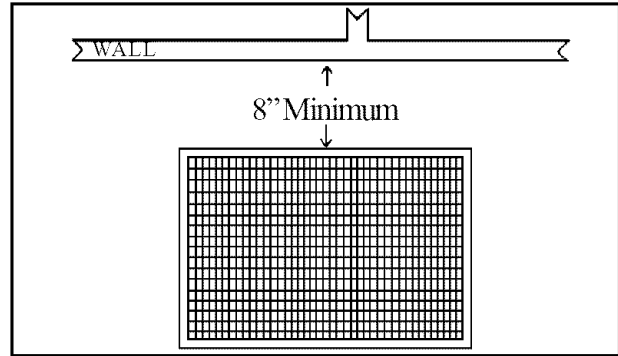

FIGURE 2

Give consideration to available air for combustion, location in relation to chimney or vent system, thermostat location, clearance under floor, clearance to combustibles, and heat circulation. Any open foundation is unacceptable as wind can cause pilot outage and reduced efficiency. Keep furniture, drapes, doors, and other combustible materials at least 12 inches from the edge of the grill. Never locate the floor furnace closer than 8 inches to a wall and never in a corner. See Figure 2.

Two adjoining sides of the floor furnace must have a minimum clearance of 18". See Figure 1.

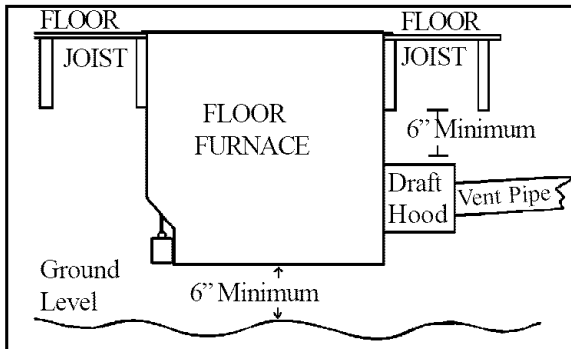

FIGURE 3

After selecting a location in the home, go beneath the floor and check the position of the floor furnace in relation to joists, supporting columns, electric wires, water pipes and walls. There must be a minimum of 6 inches clearance between the top of the draft hood and floor joists. There must also be at least 6 inches clearance between the bottom of the floor furnace and the ground. See Figure 3.

In order to find the location beneath the floor it may be necessary to drill a 1/16 inch hole through the floor approximately in the center of the selected floor furnace location to use as a reference point when measuring under the floor.

FRESH AIR FOR COMBUSTION AND VENTING

Adequate air for combustion and venting must be provided. **Any reduction in the necessary amount of fresh air can result in an oxygen starved flame that emits Carbon Monoxide (C.O.) an odorless, colorless gas that can cause serious injury or death.** A ventilated crawl space will usually provide enough fresh air. However, you must check to see that there is 1 square inch of free area of ventilation opening for each 1,000 BTU's input of your floor furnace. **EXAMPLE:** 50,000 BTU floor furnace ÷ 1,000 = 50 square inches. If another gas burning appliance such as a water heater is installed within the same crawl space or basement, add the B.T.U.'s of the other appliance to those of the floor furnace before calculating the total ventilation needed. **EXAMPLE:** 50,000 B.T.U. floor furnace plus 40,000 B.T.U. water heater equals 90,000 B.T.U. ÷ 1,000 = 90 square inches. To compensate for the loss of square inches of ventilation due to the use of louvers, grills, or screens add approximately 50% to the square inches calculated. Screen all openings with mesh not less than ¼ inch to prevent animals or insects from entering the crawl space.

All type "B" vents shall extend in a generally vertical direction with offsets not exceeding 45 degrees, except that a vent system having not more than one 60 degree offset may be allowed.

Any angle greater than 45 degrees from the vertical is considered horizontal. The total horizontal run of a vent plus the horizontal vent connector shall be not greater than 75 percent of the vertical height of the vent.

Any offsets used should be as far above the draft hood as possible to allow a venting action to begin before any restriction is encountered.

CUTTING THE FLOOR OPENING

Consult the specification chart on Page 2 for the correct floor opening size for the floor furnace to be installed. Lay out the opening size on the floor by using masking tape or cutting a piece of cardboard to the opening size. The opening must be cut square. If you have determined that there is nothing under the floor to interfere with the installation, you are now ready to cut the opening. Start by drilling $\frac{1}{2}$ inch holes inside the lines of each corner. Use a keyhole saw or a properly grounded saber saw to cut along the lines making sure to keep the lines straight and the corners square. If the opening dimensions are not correct, it may be difficult to fit the floor furnace into the opening. Forcing the floor furnace through the opening may create stresses that cause the floor furnace to be excessively noisy.

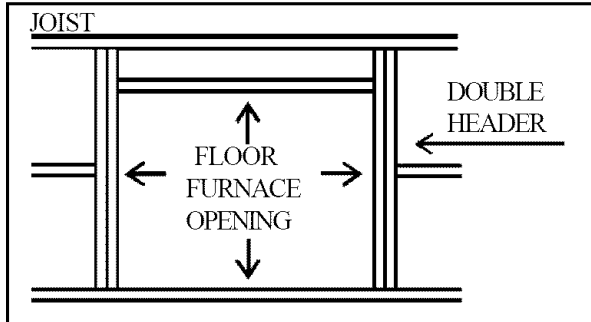

FIGURE 4

Most installation will require cutting a floor joist. Cut the floor joist so that double headers of the same size lumber can be used to frame around the floor furnace. Double headers are necessary to maintain the strength of the floor. See Figure 4.

If the clearance between the bottom of the floor furnace and the ground is not adequate, dig a pit that will provide clearances of at least 6 inches under the floor furnace, 18 inches on the end where the gas valve is located and 12 inches on the other three sides. Slope the sides of the pit to prevent dirt from caving into the pit. See Figure 5.

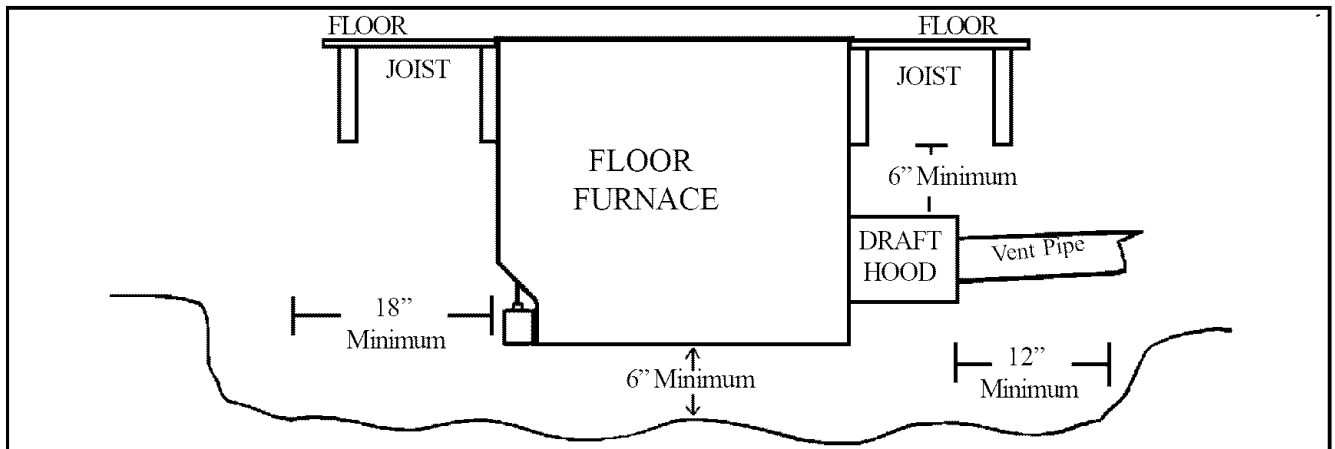

FIGURE 5

If there is any possibility that water may accumulate in the pit, a drain must be provided. If a drain cannot be provided, fabricate a waterproof pan of at least 16 ounce per square foot sheet copper or a suitable substitute. Size the pan to provide 6 inches clearance to the bottom of the floor furnace, 18 inches on the side where the gas valve is located and 6 inches on the other three sides. The sides of the pan must extend at least 4 inches above the ground. **Anchor the pan to prevent it from floating up against the bottom of the floor furnace when water is present. Failure to do so may result in the pan rising to seal off air for combustion and venting. If this occurs, carbon monoxide (C.O.) a colorless, odorless gas that can cause serious injury or death may be formed.**

SETTING THE FLOOR FURNACE

Lay aside the grill and package containing the thermostat, wires, etc., grasp two opposite sides of the outer casing and lower the floor furnace gently through the opening. Support the furnace evenly by the flange at the top of the outer casing. Trim back carpet, padding, and other types of floor covering so that the entire flange rests directly on the floor. If not evenly supported on all four sides, stresses may be created that cause excessive expansion and contraction noises as the floor furnace heats and cools. Anchor the floor furnace in place by driving two galvanized roofing nails through each side of the outer casing into the double headers approximately 1 inch below the flange. Place the grill into position making sure it lays flat against the outer casing flange. Leave the grill in place until time to light the furnace to keep occupants from falling into the furnace.

INSTALLING THE DRAFT HOOD

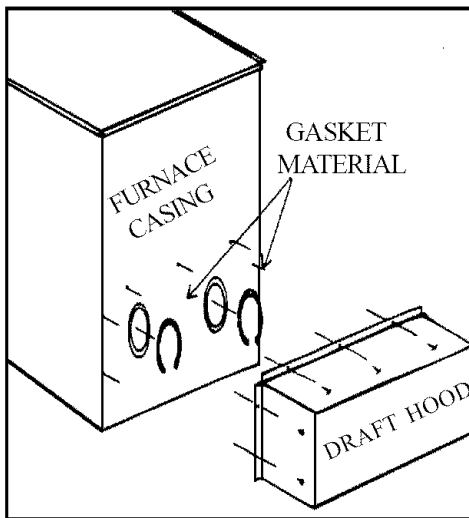

FIGURE 6

The draft hood must be installed in the same atmospheric pressure zone as the combustion air inlet. The draft hood is packed in its own carton within the master pack. Make sure the draft hood received is the correct one for the floor furnace being installed. Included in the carton are two rope-like gaskets and 7 sheet metal screws. Begin by pressing the rope-like gasket material into the groove provided around the two male vent outlets on the floor furnace. See Figure 6.

Slip the two female couplings in the draft hood over the male outlets extending through the outer casing, making sure the gaskets remain in place. Press the draft hood tight against the casing and use the 7 sheet metal screws to secure it tightly. All 7 screws must be used to prevent leakage of vent gases. **Never install or operate a floor furnace without a draft hood. To do so could result in serious injury, property damage or death.**

CONNECTING THE VENT

Refer to the specifications on Page 2 for the correct vent pipe size. Familiarize yourself with local codes or contact authorities to determine the approved material and method of installing the vent. NOTE: An existing vent that has worked for years may not be adequate for today's design because of higher efficiency requirements that result in lower stack temperatures.

Improper or unsafe venting presents a hazard that may result in property damage, bodily injury or loss of life. Listed below are some guidelines to observe when installing the vent system.

1. Never reduce the vent pipe to a size smaller than the outlet on the draft hood.
2. Never run pipe more than 15 feet horizontally.
3. The total horizontal run of a vent plus the horizontal vent connector shall be not greater than 75 percent of the vertical height of the vent.
4. Slope horizontal pipe upwards at least $\frac{1}{4}$ inch per lineal foot.
5. Do not use more than one elbow. An elbow restricts the flow of vent gases by approximately 10%.
6. Use a noncombustible thimble when connecting vent pipe to a masonry chimney.
7. Do not insert vent pipe farther than $\frac{1}{4}$ inch into the interior of the chimney.
8. Single wall pipe must not be used.
9. Never connect the vent pipe to any chimney or vent system serving a solid fuel-burning appliance.
10. If another appliance is being vented through the vent system with the floor furnace, the vent pipe must be increased to compensate for the additional load.
11. Never install any kind of damper in the vent system.
12. Do not use transite or any other type of ceramic pipe for venting.

Class "B" double wall pipe is acceptable to most codes, and if installed in accordance with the pipe manufacturer's instructions provides the safest and most efficient vent system. Class "B" pipe has an integral lock for securing sections together. These locks must be properly fitted together. Fasten pipe to draft hood using at least three self-tapping sheet metal screws at equal intervals around the circumference of the pipe. Support horizontal pipe at three-foot intervals with metal strapping attached to joists.

The floor furnace you have selected was carefully designed to operate both safely and efficiently when vented with the proper size vent listed for each furnace on Page 2 of these instructions. We do not recommend doing so, but if you must vent into a masonry chimney use the following instructions.

Continued – next page

CONNECTING THE VENT - Continued

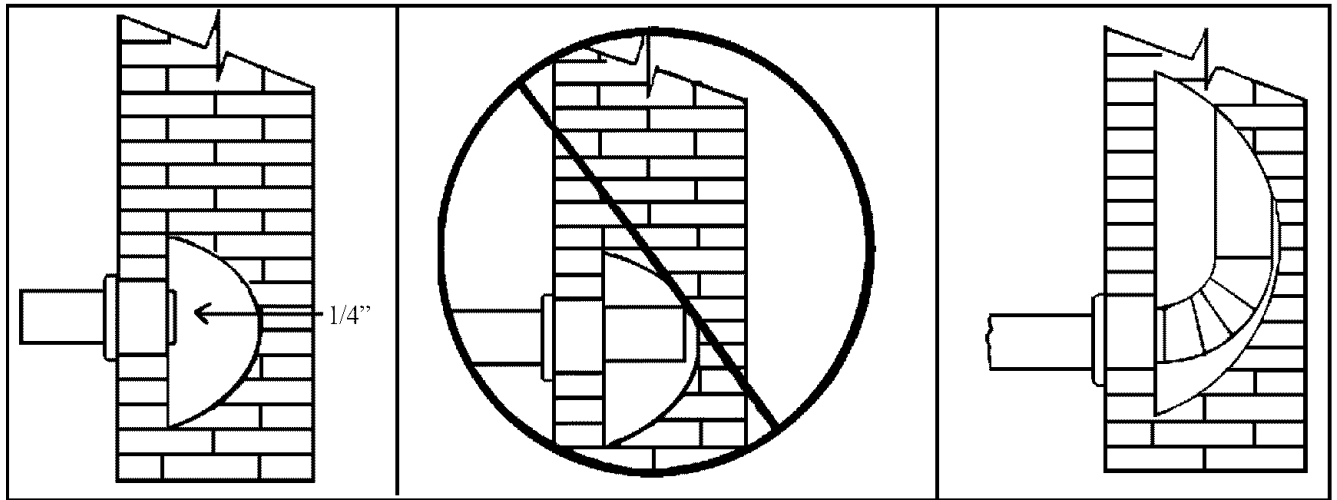

SAFE
FIGURE 7A

UNSAFE
FIGURE 7B

RECOMMENDED
FIGURE 7C

If the floor furnace is vented into a masonry chimney, the chimney must be inspected to determine that it is clear and free of obstructions and that it is safe for the intended use. The inside of the chimney must be at least 6 inches in diameter or 6 inches by 6 inches if rectangular. Insert the vent pipe into the chimney through a masonry or noncombustible corrosion-resistant thimble of the correct diameter. Do not push the pipe farther than 1/4 inch into the inside of the chimney. See Figure 7A. Pushing the pipe farther into the inside of the chimney may cause partial or complete blockage as illustrated in Figure 7B.

Even following these instructions you may still have a venting problem because of the larger area to be heated inside the chimney. This could cause pilot outage, odors coming from the furnace, or noise due to excessive heat not being vented out of the combustion chamber. If you experience any of these problems, we recommend running the proper size "B" type vent pipe down the chimney and connecting to the horizontal run of vent pipe with a 90-degree elbow inside the chimney. See Fig. 7C.

Extend the vent system at least 3 feet above the point where it exits the roof and at least two feet higher than any part of the roof system within 10 feet. Terminate with a listed or approved cap. See Figure 9.

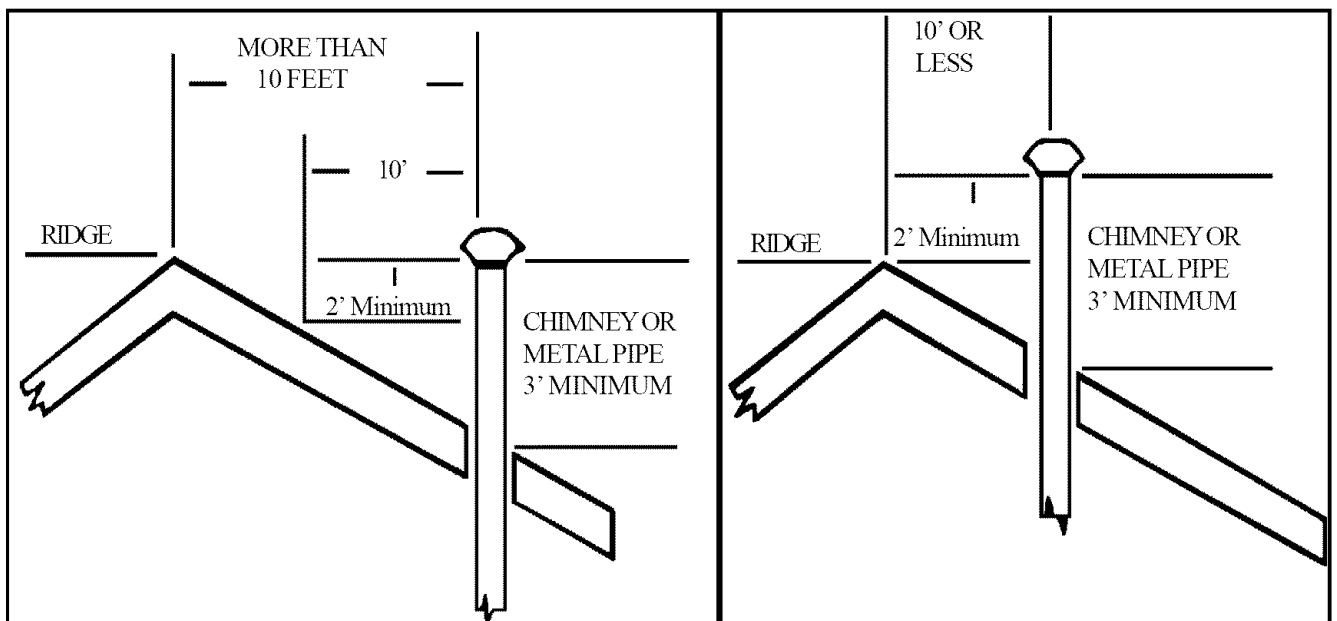

FIGURE 9

FIGURE 9

CONNECTING THE VENT - Continued

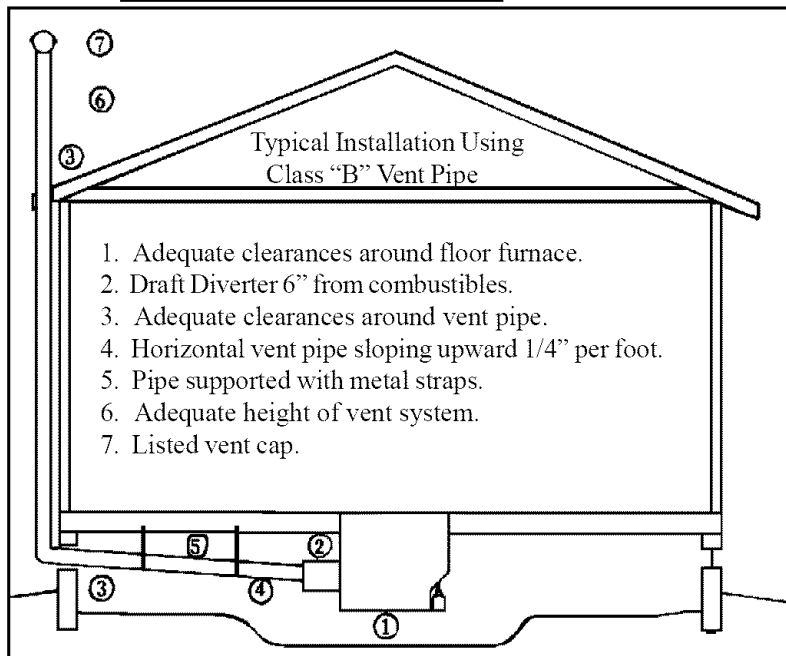

FIGURE 10

If more than one gas appliance is vented through a common vent system, the vent should be increased in size to accommodate the increased load. Consult your local code or the tables in the latest edition of NFPA54/ANSI.Z223.1 for the correct size. If no local codes apply, use the following alternate method for sizing a vent connected to more than one appliance. The effective area of the vent must be not less than the area of the largest vent connection plus 50 percent of the areas of additional draft hood outlets.

The homeowner appreciates neatness in workmanship and the neat installation usually functions better than the sloppy one. Double check your work to verify that all clearances around the floor furnace and vent system are adequate and that the vent system is installed to code or pipe manufacturers specifications. See Figure 10.

GAS SUPPLY AND PIPING

The gas piping system must meet the requirements of local codes or the specifications of the servicing gas supplier. It must have adequate capacity to supply the floor furnace and any other appliance within the home with enough gas to maintain the full rated capacities without excessive pressure drop when all appliances are operating at full rate.

GAS PIPE SIZES - CAPACITY - *NATURAL GAS

Length of Pipe - Feet	INSIDE PIPE DIAMETER			
	1/2"	3/4"	1"	
10	132,000	278,000	520,000	Capacity B.T.U. Per Hour Input
20	92,000	190,000	350,000	
30	73,000	152,000	285,000	
40	63,000	130,000	245,000	
50	56,000	115,000	215,000	
60	50,000	105,000	195,000	

*Based on heating value of 1,000 btu per cubic foot (specific gravity of 0.6) @ 0.5 PSIG and a pressure drop of 0.3 inch water column.

GAS TUBING AND PIPE SIZES - CAPACITY -

*L.P. GAS

Length of Pipe/Tubing Feet	**Copper Tubing Outside Diameter		**Steel Pipe Inside Diameter		
	1/2"	3/4"	1/2"	3/4"	
10	92,000	329,000	275,000	567,000	Capacity B.T.U. Per Hour Input
20	62,000	216,000	189,000	393,000	
30	50,000	181,000	152,000	315,000	
40	41,000	145,000	129,000	267,000	
50	37,000	131,000	114,000	237,000	
60	35,000	121,000	103,000	217,000	

*Undiluted Liquefied Petroleum Gas @ 11 inches water column inlet pressure. Based on a pressure drop of 0.5 inches water column.

**Copper tubing must comply with limitations of NATIONAL FUEL GAS CODE reference 2.6.3 metallic tubing.

***Steel pipe should be of at least standard weight (Schedule 40).

Support the piping or tubing at regular intervals with metal pipe strapping. See chart below.

Nominal Steel Pipe Size	Spacing of Supports
1/2"	6'
3/4" or 1"	8'

Nominal size of tubing O.D.	Spacing of Supports
1/2"	4'
5/8" or 3/4"	6'

Where local conditions include earthquake, tornado, unstable ground or flood hazards, give special consideration to increased strength and flexibility of piping supports and connections. Consult local authorities for recommendations.

All unused openings in the piping system must be securely closed gas-tight.

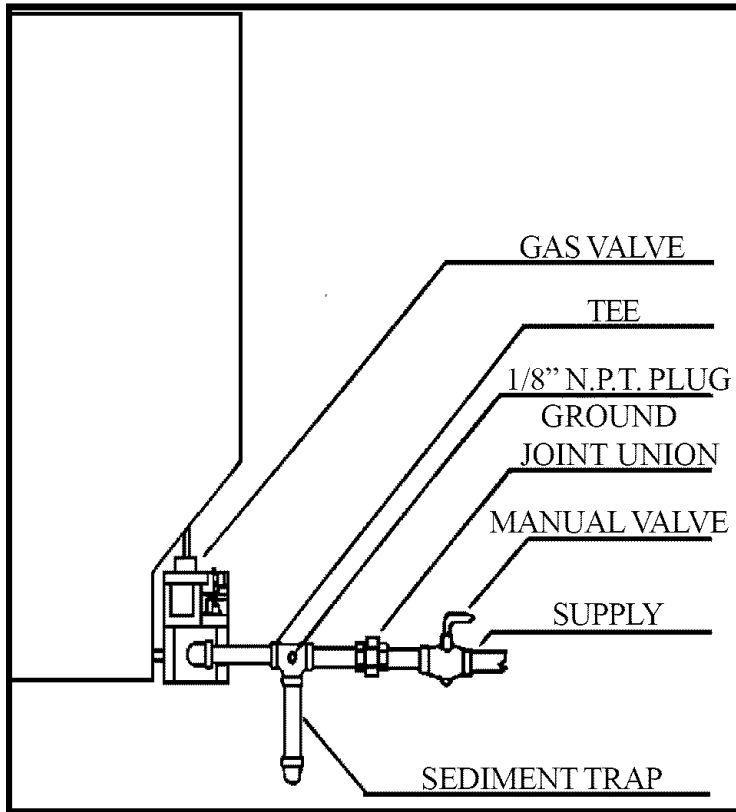

FIGURE 11

CONNECTING THE GAS PIPING

Refer to Figure 11 for the basic fittings you will need at the furnace.

1. Use black iron or steel pipe and fittings or other pipe and fittings that are approved by local codes.
2. Use pipe joint compound that is resistant to the action of Liquefied Petroleum (L.P.) Gas or to any other chemical constituents of the gases to be conducted through the piping only on male threads.
3. Use two wrenches when making the connection to the valve to keep from bending the mounting bracket or manifold pipe. Do not overtighten as damage to the valve can occur.
4. Provide a 1/8" nominal pipe thread (NPT) plugged tapping for test gauge connection immediately upstream of the gas supply connection to the floor furnace.
5. Provide a sediment trap at least 6 inches long to trap dirt and moisture. Provide space to permit cleaning or emptying.
6. Use a ground joint union.
7. Install an approved manual shut-off valve.

ADDITIONAL L.P. GAS REQUIREMENTS

8. Have all connections made at the storage tank by a licensed L.P. Gas installer.
9. Have L.P. Installer check all lines, piping, and connections from the storage tank to the floor furnace when the floor furnace is connected to the storage tank.
10. The regulator on the storage tank should be set at 11 inches water column.

CHECKING THE GAS PIPING

All joints must be tested for leaks by applying pressure to the piping system. If the test pressure is equal to or less than ½ PSIG the floor furnace must be isolated from the gas supply piping system by closing the manual gas shut-off valve on the floor furnace. If the test pressure exceeds ½ PSIG, the floor furnace and its manual gas shut-off valve must be disconnected from the gas piping system before testing. **Failure to do so may result in damage to the pressure regulator in the gas valve resulting in overfiring. Overfiring can result in combustion chamber failure, property damage, bodily injury or death.**

Use a mixture of soap and water or liquid detergent to check each joint. Leaks will be indicated by bubbles forming. Correct even the smallest leak at once. Since some soaps may cause corrosion, or stress cracking, rinse the gas piping exterior with water after testing to remove the soap.

WARNING

Never use a match, candle, open flame or other method which could provide a source of ignition to test for leaks. To do so may result in property damage, bodily injury or death.

CAUTION: Label all wires prior to disconnection when servicing controls. Wiring errors can cause improper and dangerous operation. Verify proper operation after servicing.

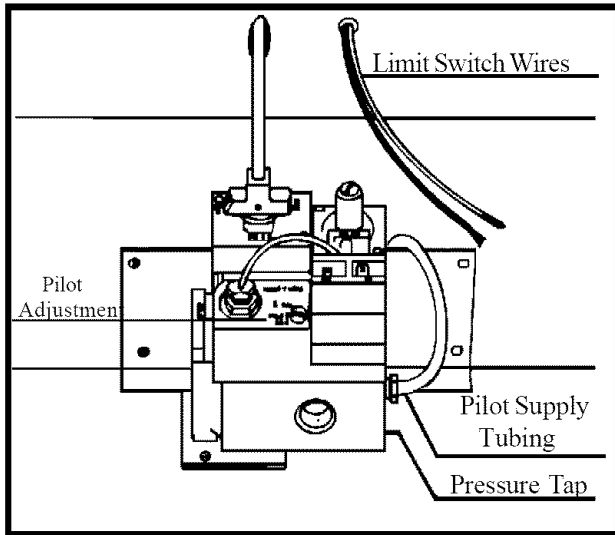

FIGURE 12

CHECKING THE GAS PIPING - CONTINUED

When you have determined that there are no leaks in the gas piping system you may purge the system of air. Disconnect the pilot supply tubing from the right side of the valve. See Figure 12.

Turn the knob on the gas valve to the pilot position. Press the knob down and hold until you smell gas at the pilot supply opening. Release the knob and turn it to the off position. Reconnect the pilot supply tubing and check for leaks with soap and water or liquid detergent.

WARNING

When purging gas piping, the area around the floor furnace must be well ventilated to allow any gas to dissipate. Liquid Petroleum (L.P.) Gas is heavier than air and may puddle in low places under the floor. Check thoroughly to determine that no gas is present before lighting the floor furnace. Failure to do so could result in property damage, bodily injury or death.

THERMOSTAT INSTALLATION

Follow the instructions included with the thermostat. Locate the thermostat approximately five feet above the floor. Always mount the thermostat on an inside wall where it won't be affected by heat or cold sources such as direct sunlight, televisions, fireplaces, hidden hot or cold water pipe, drafts, etc. The thermostat must never be installed in an adjoining room where a door can be closed between the thermostat and floor furnace. This floor furnace is equipped with a self-generating control system. Never connect to a 24-volt transformer or to the household electric system. Do not use more thermostat wire than is included with the floor furnace.

WIRE AS INDICATED: (See Figure 13)

- Step 1. Connect black limit switch wire to black thermostat wire using wire nut. (Nut not furnished).
- Step 2. Connect white thermostat wire to terminal on gas valve marked "TH PP".
- Step 3. Connect white limit switch wire to terminal on gas valve marked "TH".
- Step 4. Connect the thermostat wires to the thermostat following the instructions provided by the thermostat manufacturer.

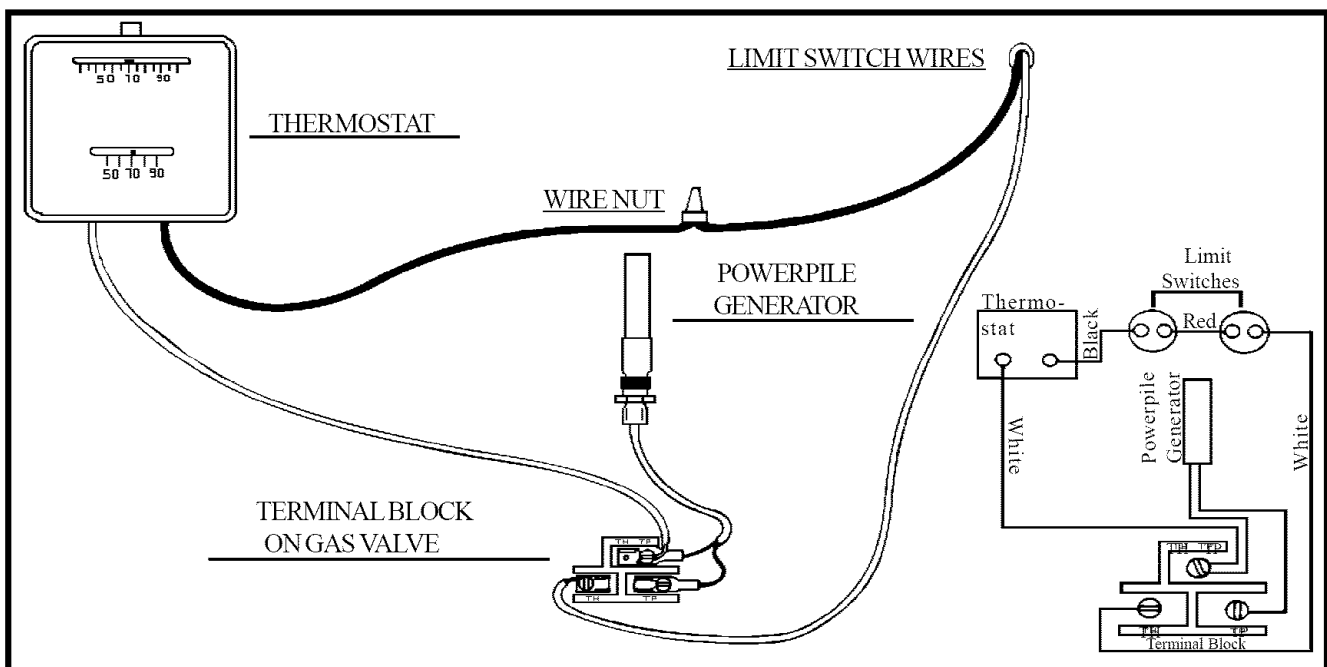

FIGURE 13

FOR YOUR SAFETY READ BEFORE LIGHTING

WARNING: If you do not follow these instructions exactly, a fire or explosion may result causing property damage, personal injury or loss of life.

- A. This appliance has a pilot which must be lighted by hand. When lighting the pilot, follow these instructions exactly.
- B. BEFORE LIGHTING smell all around the appliance area for gas. Be sure to smell next to the floor because some gas is heavier than air and will settle on the floor.

WHAT TO DO IF YOU SMELL GAS:

- Do not try to light any appliance.
- Do not touch any electric switch; do not use any phone in your building.
- Immediately call your gas supplier from a neighbor's phone. Follow the gas supplier's instructions.
- If you cannot reach your gas supplier, call the fire

department.

- C. Use only your hand to push in or turn the gas control knob. Never use tools. If the knob will not push in or turn by hand, don't try to repair it, call a qualified service technician. Force or attempted repair may result in a fire or explosion.
- D. Do not use this appliance if any part has been under water. Immediately call a qualified service technician to inspect the appliance and to replace any part of the control system and any gas control which has been under water.

LIGHTING INSTRUCTIONS

1. STOP! Read the information on the safety label.
2. Set thermostat to lowest setting.
3. Remove the floor grille.
4. Place the furnace key on the control rod, push down slightly and turn clockwise ↻ to "ALL OFF".

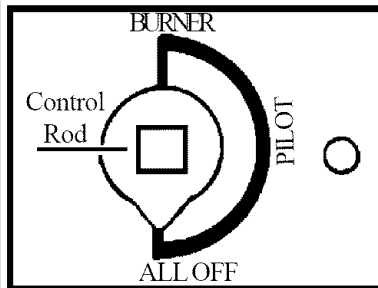

NOTE: Control rod cannot be turned from "PILOT" to "ALL OFF" unless the control rod is pushed down slightly.

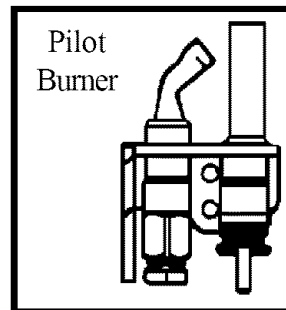

Pilot is located on the side of and toward control end of burner

5. Wait five (5) minutes to clear out any gas. Then smell for gas, including near the floor. If you smell gas, STOP! Follow "B" in the information on the safety label. If you don't smell gas, go to the next step.
6. Remove the sight glass assembly from the opening on top of the heat exchanger.
7. Locate the pilot burner looking down through the sight glass opening.
8. Turn the control rod counterclockwise ↶ until the pointer is on "PILOT".
9. Locate the red piezo igniter button beside the control rod.
10. Press down on the control rod with the furnace key. Immediately begin a series of pushing and releasing the red piezo igniter while observing the pilot through the sight glass opening, continue to spark until pilot is lit or use the lighter rod with match. Continue to hold the control rod down for about one (1) minute after the pilot is lit. If it goes out, repeat steps 4 through 10.
 - If control rod does not pop up when released, STOP and immediately call your service technician or gas supplier.
 - If the pilot will not stay lit after several tries, turn the control rod to "OFF" and call your service technician or gas supplier.
11. Replace the sight glass assembly and turn the control rod counterclockwise ↶ to "BURNER" position. Remove furnace key and replace the floor grille.
12. Set thermostat to desired temperature.

TO TURN OFF GAS TO APPLIANCE

1. Set the thermostat to it's lowest setting.
2. Allow floor grille to cool, then remove.
3. Place furnace key on control rod, push slightly and turn clockwise ↻ to "ALL OFF". Do not force.
4. Replace floor grille.

VENT SYSTEM

After the floor furnace has been burning for five minutes, hold a match or candle under the draft hood at the air intake area. If the vent system is working properly, the flame will be pulled into the air inlet of the draft hood. If the vent system is not working properly, turn the floor furnace off immediately and refer to the installation instructions or local code for proper installation procedure.

ADJUSTING THE PILOT FLAME

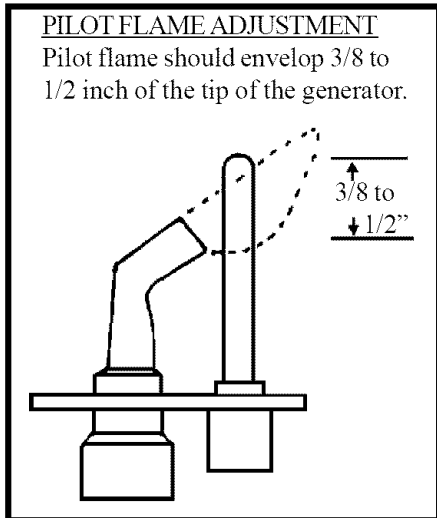

FIGURE 17

Refer to Figure 17 for the correct size pilot flame. If adjustment is necessary, refer to Figure 12 for the location of the pilot adjustment screw. Using a standard screwdriver, remove the pilot adjustment screw cover. Insert a small screwdriver into the pilot adjustment screw and turn clockwise to decrease the flame or counterclockwise to increase the flame. If the flame is too low, the safety pilot may cause all of the gas to be cut off. NOTE: The gas supply to the pilot is unregulated. When line pressure exceeds 7" Natural Gas, or 11" L.P. Gas, a pilot adjustment must be made.

BURNER ORIFICE

This appliance is orificed at the factory for elevations up to 2,000 feet. If installed above 2,000 feet, the BTU input must be reduced 4% per 1,000 feet. See the following orifice chart for the proper orifice for a specific elevation.

NATURAL GAS SPECIFIC ELEVATIONS

Model No.	0 to 2,000'	2,000 - 4,000'	4,000 - 6,000'	6,000 - 8,000'	8,000 - 10,000'
90N30A	38	41	42	43	44
90N50A	30	31	31	32	35
90N65A	26	28	29	30	30
ORDER KIT #49800	44-1 HIGH ALTITUDE KIT				
90N75A	33	36	37	38	41
ORDER KIT #49850	2287-2 HIGH ALTITUDE KIT				

L.P. GAS SPECIFIC ELEVATIONS

Model No.	0 to 2,000'	2,000 - 4,000'	4,000 - 6,000'	6,000 - 8,000'	8,000 - 10,000'
90P30A	1/16	53	53	54	54
90P50A	47	49	49	50	51
90P65A	43	44	45	47	48
ORDER KIT #49800	44-1 HIGH ALTITUDE KIT				
90P75A	51	52	52	53	54
ORDER KIT #49850	2287-2 HIGH ALTITUDE KIT				

ADJUSTING THE BURNER

After the floor furnace has been burning 15 minutes, remove the bottom pan from the outer casing exposing the complete burner assembly. Loosen the screw at the bottom side of the sliding air shutter. Slide the air shutter closed until yellow tips start to appear at the top of the flame. See Figure 19. (75,000 BTU floor furnace has two burners, both of which may need adjustment). Now open the shutter slightly beyond the point that the yellow disappears and the flame burns blue. (See Figure 20). Airborne dust particles may cause flashes or streaks of yellow flame as they are drawn into the flame but will have no effect on the efficiency of the floor furnace. If you are satisfied that the burner is properly adjusted, tighten the set screw to lock the shutter in position. Replace the bottom pan. Check air shutter setting at least twice each season to assure that changing conditions are not causing yellow tipping.

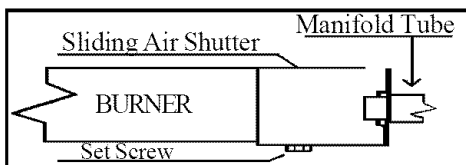

FIGURE 18

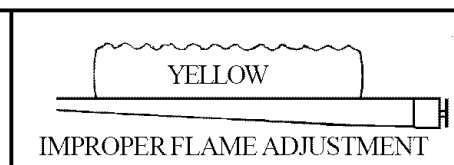

FIGURE 19

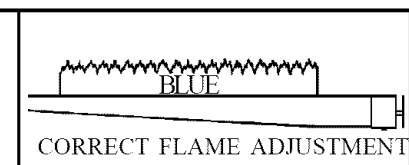

FIGURE 20

ADJUSTING THE BURNER – Continued

If difficulty in adjusting the burner is experienced, it may be the result of incorrect gas supply pressure or manifold pressure. Pressure can only be checked and adjusted by a trained service technician using instruments designed for that purpose.

WARNING: Do not attempt to change pressure settings without proper training and instruments. To do so may cause your floor furnace to malfunction resulting in property damage, bodily injury, or death.

The following information is provided for use by a trained service technician with measuring instruments.

Minimum Inlet Pressure, Natural Gas.....	4.5 Inches Water Column
Minimum Inlet Pressure, Liquefied Petroleum (L.P.) Gas.....	11.0 Inches Water Column

Maximum Inlet Pressure for Natural Gas.....	7.0 Inches Water Column
Maximum Inlet Pressure, Liquefied Petroleum (L.P.) Gas.....	14.0 Inches Water Column

(If the inlet pressure is found to exceed 14.0 inches water column, check the performance of the control valve thoroughly as damage may have occurred. If manifold pressure cannot be adjusted, replace the control valve).

Manifold Pressure, Natural Gas.....	3.5 Inches Water Column
Manifold Pressure, Liquefied Petroleum (L.P.) Gas.....	10.0 Inches Water Column

OPTIONAL OPERATION

Your floor furnace has been designed to meet all safety requirements of the American National Standards Institute and government regulations by offering two modes of operation.

OPTION 1. Place the furnace key on the damper control rod (See Figure 21) and turn counterclockwise  until the warning flag is concealed and the damper is open. Your floor furnace will now cycle on and off maintaining a moderate grill temperature and an even room temperature. Your floor furnace will function best on this setting during mild weather.

OPTION 1

In mild weather, operate furnace with damper open. Furnace will cycle on and off maintaining a moderate grill temperature and an even room temperature.

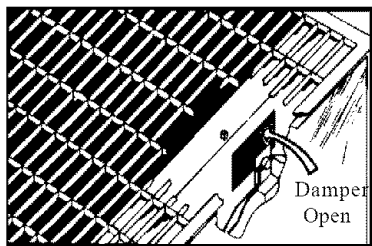



FIGURE 21

WARNING

FLOOR FURNACE GRILLS BECOME HOT WHEN FURNACE IS IN OPERATION. CONTACT OF BARE SKIN WITH GRILL MAY RESULT IN SEVERE BURNS. KEEP CHILDREN OFF, PROVIDE FENCE OR REGISTER GUARD FOR THEIR PROTECTION.

OPTION 2. Turn the furnace key clockwise  until the warning flag reading “**WARNING – GRILL IS HOT – Keep off – can cause burns**” is visible and the damper is closed. The limit control will now cease to function and the floor furnace will now put out the maximum amount of heat until the room temperature reaches the thermostat setting. Use this option only in extremely cold weather. If furnace continues to cycle on limits, assure that damper door is 100% closed by adjusting damper door pin if necessary.

OPTION 2

In extremely cold weather, close damper (which exposes warning plate). Furnace will then put out maximum amount of heat until room temperature reaches setting on wall thermostat.

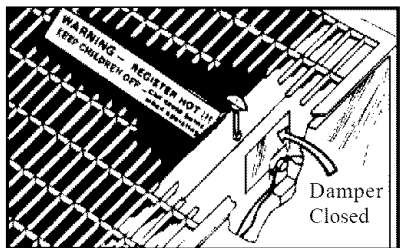

FIGURE 22

LIMIT SWITCH	
<u>TEMPERATURE SETTINGS</u>	
90 {N,P} 30A.....	140°
90 {N,P} 50A.....	160°
90 {N,P} 65A.....	180°
90 {N,P} 75A.....	170°

MAINTENANCE INSTRUCTIONS

CAUTION: Label all wires prior to disconnection when servicing controls. Wiring errors can cause improper and dangerous operation.

For proper operation, Floor Furnace must be kept clean. At regular intervals turn control valve to off, let cool, remove register and clean dust and foreign material from jacket with vacuum cleaner.

Have the Floor Furnace checked by a qualified service technician for venting system, pilot, and burner operation prior to its use each year.

Follow a regular service and maintenance schedule for safe and efficient operation.

Keep flammable materials away from floor furnace area.

Be sure not to obstruct combustion and ventilation air.

TO CLEAN BURNER

1. Remove bottom pan from outer casing.
2. Remove 2 screws from burner support bracket.
3. Remove 2 screws from pilot bracket allowing burner to slide off of manifold and out of floor furnace.
4. Examine the burner. If any distortion is noticed, replace burner.
5. Clean burner ports by inserting a toothpick in ports to remove any debris that might have accumulated.
6. Inspect burner for spider webs or dust buildup during the off-season. If necessary, wash out with garden hose.
7. Re-install and adjust burner.

WARNING

Do not use any kind of solvent or cleaning fluid to clean your floor furnace. It may leave a residue or invisible coating that will burn or smell when you turn your floor furnace on. Use only a damp cloth.

Repair service must be performed by qualified persons. The floor furnace must be inspected before initial use. An annual cleaning of floor furnace and safety performance check should be made by a qualified service person. More frequent cleaning may be required when exposed to the excessive lint conditions due to carpeting and bedding material, etc. It is imperative that the control compartment, burners, and circulating air passageways of the floor furnace be kept clean. Any safety screen or guard removed for servicing the floor furnace must be replaced prior to operating heater.

Examine the entire venting system as a routine part of the safety performance check on an annual basis.

WARNING

This is a gas-fired floor furnace. Keep the area clear of gasoline and other flammable vapor and liquids. All combustible material must be kept clear of this area to avoid fire or explosion.

SERVICE RECORD	SERVICE RECORD	SERVICE RECORD	SERVICE RECORD

TROUBLE SHOOTING CHART - MAIN BURNER

SYMPTOM	POSSIBLE CAUSES	CORRECTIVE ACTION
Flame too large	<ol style="list-style-type: none"> 1. Defective operator section of gas valve. 2. Burner orifice too large. 3. If installed above 2,000 ft. 	<ol style="list-style-type: none"> 1. Replace complete valve. 2. Check with local gas company for proper orifice size and replace. 3. Refer to Burner Orifice Section, Pg. 12.
Flame pops back	Too much primary air.	Adjust air shutter. See Page 12.
Noisy Flame	<ol style="list-style-type: none"> 1. Too much primary air. 2. Noisy pilot. 3. Burr in orifice (if it whistles or resonates). 4. Excessive gas input. 	<ol style="list-style-type: none"> 1. Adjust air shutter. See Page 12. 2. Reduce pilot gas with adjusting screw marked pilot on combination gas control valve. See Page 12. 3. Remove burr or replace orifice. (Do not enlarge orifices). 4. See "Flame Too Large" above.
Yellow tip flame (some yellow tipping on L.P. gas is permissible)	<ol style="list-style-type: none"> 1. Too little primary air. 2. Clogged main burner ports. 3. Clogged draft hood. 4. Linted up air shutter. 	<ol style="list-style-type: none"> 1. Adjust air shutter. See page 12. 2. Clean main burner ports. (Do not enlarge ports). 3. Clean draft hood. 4. Check for dust or lint at air mixer opening and around the shutter.
Floating flame	<ol style="list-style-type: none"> 1. Blocked venting. 2. Insufficient primary air. 	<ol style="list-style-type: none"> 1. Clean flue passage ways to remove blockage. 2. Adjust air shutter to increase primary air supply.
Gas odor	<ol style="list-style-type: none"> 1. Chimney or vent obstruction. 2. Drafts around appliance. 3. Gas leak. 	<ol style="list-style-type: none"> 1. Clean chimney or vent - replace if necessary. 2. Eliminate drafts. 3. See Page 1.
Delayed ignition	<ol style="list-style-type: none"> 1. Pilot flame too small. 2. Burner ports clogged near pilot. 3. Low gas pressure. 4. Pilot decreases in size when main burners come on. 5. Air shutter open too far. 6. Drafts around appliance. 7. Bad venting. 	<ol style="list-style-type: none"> 1. Check pilot orifice, close, increase pilot gas flow if necessary by adjusting at combination control valve. See Page 12. 2. Clean burner ports (Do not enlarge ports). 3. Check gas supply pressure. 4. Supply piping is inadequately sized. Consult local gas utility or competent installer. 5. Close air shutter to proper setting as outlined in these instructions (slight yellow tipping is allowable on L.P. gas). 6. Eliminate drafts. 7. See "Venting".
Failure to ignite	<ol style="list-style-type: none"> 1. Main gas off. 2. Defective gas valve. 	<ol style="list-style-type: none"> 1. Open all manual gas valves. 2. Replace gas valve.
Condensation of water vapor	1. Improper venting.	1. See "Venting".
Burner won't turn off	<ol style="list-style-type: none"> 1. Defective or sticking automatic valve. 2. Excessive gas pressure (The supply gas pressure must not exceed 1/2 psi or 14" water column). 	<ol style="list-style-type: none"> 1. Clean or replace valve. 2. To correct this situation contact the utility supplying the gas.
Incorrect gas input	<ol style="list-style-type: none"> 1. Gas input not checked. 2. Clogged orifice. 	<ol style="list-style-type: none"> 1. Recheck gas input. 2. Check orifice for clogging. If clogged, clean out the hole carefully with a smooth wood toothpick. (Do not in any way enlarge or distort it).
Not enough heat	<ol style="list-style-type: none"> 1. Appliance undersized 2. Thermostat set too low. 3. Incorrect supply pressure. 	<ol style="list-style-type: none"> 1. This is especially true when a dwelling or room is enlarged. Have the heat loss calculated and compare to the appliance output (70% of input). Your gas company or installer can supply you with this information. If appliance is undersized, replace with correct size unit. 2. Setting of thermostat. See "Lighting and Shutting Down Instructions". 3. Check supply pressure as outlined above.
Too much heat	<ol style="list-style-type: none"> 1. Thermostat set too high. 2. Combination control valve sticks open. 	<ol style="list-style-type: none"> 1. Lower setting of temp. dial. See "Lighting and Shutting Down Instructions". 2. Replace combination control valve.

TROUBLE SHOOTING CHART - AUTOMATIC PILOT & VALVE

Burner won't turn on	<ol style="list-style-type: none"> 1. Pilot flame too large or too small. 2. Dirt in pilot orifice. 3. Defective automatic pilot section in combination control valve. 4. Defective Thermocouple. 5. Defective combination control valve. 	<ol style="list-style-type: none"> 1. Readjust pilot flame using adjustment screw marked "Pilot" on combination control valve. See Page 10. 2. Clean pilot orifice with air or solvent, do not ream. 3. Replace entire combination control valve. 4. Replace thermocouple. 5. Replace valve.
----------------------	----------------------------------------------------------------------------------------------------------------------------------------------------------------------------------------------------------------------------------------------------------------------------------------------	-------------------------------------------------------------------------------------------------------------------------------------------------------------------------------------------------------------------------------------------------------------------------------------------------------------------------------------------------



MODELS INCLUDED:

- 90N30A NAT.
- 90N50A NAT.
- 90N65A NAT.
- 90N75A NAT.

GAS FLOOR FURNACE LIST PRICES

Prices and specifications subject to change without notice. All prices are F.O.B. factory. Specify model number when ordering parts.

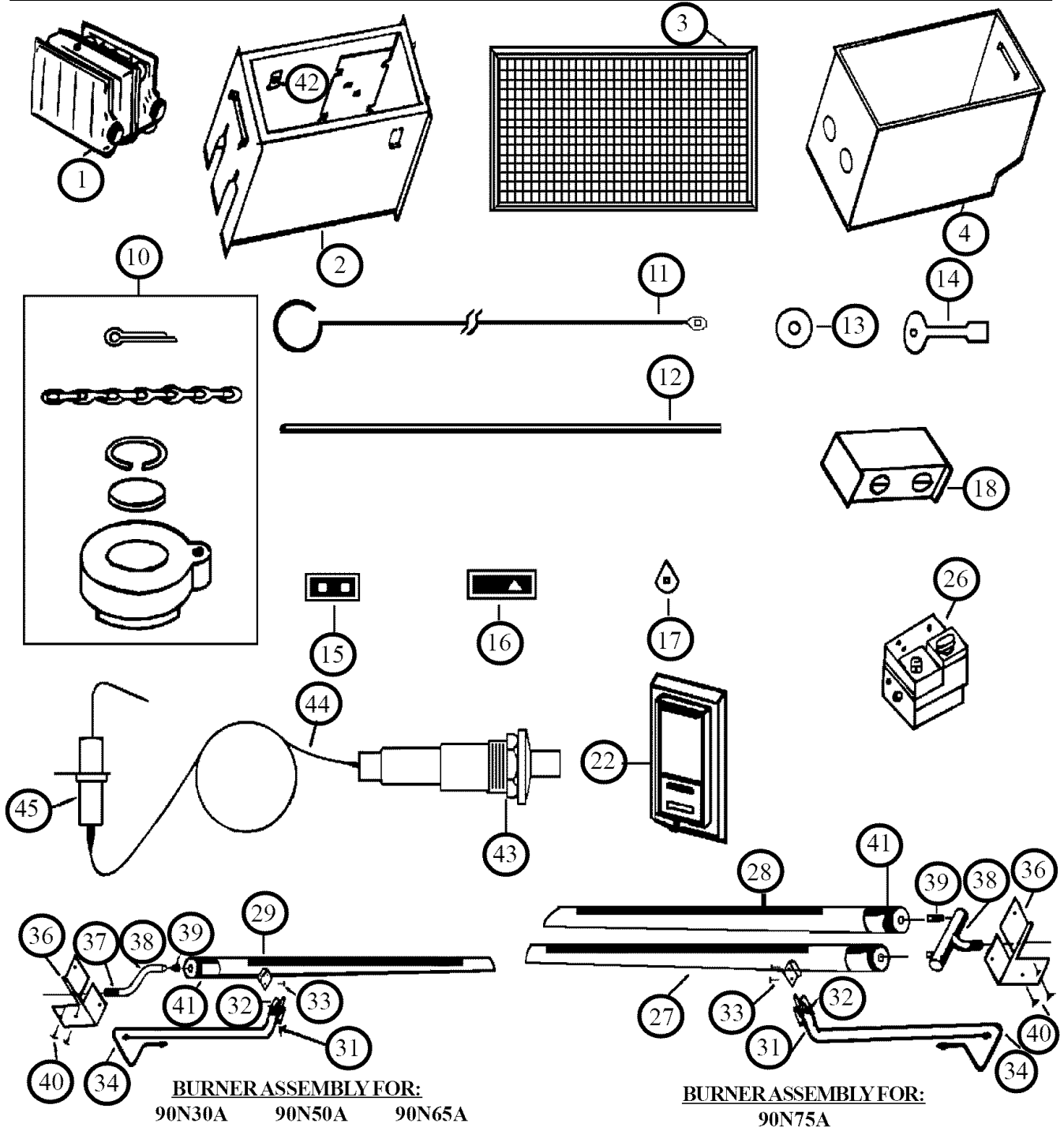

Mr. Contractor, we only sell parts through our wholesalers, but the prices listed are for your convenience. For prompt parts service, contact the wholesaler from which you purchased your Cozy heater. NOTE: Parts & schematic drawings on current models are shown at www.cozyheaters.com.

MARCH 2005

HOW TO PROPERLY ORDER PARTS: In addition to part description and part number, please give model number, serial number, and type of gas used. This information can be found on the rating plate that is attached to heater.

MODEL NUMBER	NAT.	90N30A		90N50A		90N65A		90N75A	
	REF. NO.	PART NO.	LIST PRICE	PART NO.	LIST PRICE	PART NO.	LIST PRICE	PART NO.	LIST PRICE
Heat Exchanger w/Gasket	1	23074	\$206.20	24099	\$291.10	24499	\$331.90	24699	\$370.40
Gasket, Heat Exchanger	N/A	74530	\$4.20	74530	\$4.20	74532	\$5.90	74535	\$7.20
Liner, Complete Assembly	2	23001	\$167.60	23980	\$148.90	24380	\$161.00	24580	\$202.90
Grille, Floor	3	23145	\$142.30	24175	\$180.80	24475	\$230.50	24675	\$270.20
Casing, Complete Assembly	4	23040	\$159.90	24002	\$183.00	24402	\$210.60	24602	\$227.10
Vision Cap, Complete Assy.	10	24048	\$14.10	24048	\$14.10	24048	\$14.10	24048	\$14.10
Lighter Rod	11	74510	\$2.10	74510	\$2.10	74510	\$2.10	74510	\$2.10
Valve Rod	12	24035	\$3.70	24035	\$3.70	24035	\$3.70	24642	\$3.80
Washer, Valve Rod	13	24044	\$1.20	24044	\$1.20	24044	\$1.20	24044	\$1.20
Key, Furnace	14	74205	\$1.20	74205	\$1.20	74205	\$1.20	74205	\$1.20
Instruction Plate, Lighting	16	91256	\$4.50	91256	\$4.50	91256	\$4.50	91256	\$4.50
Valve Rod Indicator Plate	17	24045	\$1.90	24045	\$1.90	24045	\$1.90	24045	\$1.90
Drafthood Assembly w/Gasket	18	23200	\$74.40	24075	\$81.10	24477	\$83.80	24676	\$88.50
Drafthood Gasket w/Screws	19	23225	\$3.70	24077	\$4.80	24077	\$4.80	24077	\$4.80
Thermostat, Millivolt	22	74592	\$20.00	74592	\$20.00	74592	\$20.00	74592	\$20.00
Wire, Thermostat 20'	23	74518	\$1.30	74518	\$1.30	74518	\$1.30	74518	\$1.30
Staples, Thermostat Wire	24	74209	\$1.20	74209	\$1.20	74209	\$1.20	74209	\$1.20
Valve, VS821A1061 Nat. Gas M.V.	26	74315	\$164.30	74315	\$164.30	74315	\$164.30	74315	\$164.30
Disappearing Bushing 1/4x3/8	37	74414	\$2.00	74414	\$2.00	74414	\$2.00	74414	\$2.00
L.P. Conversion Kit	N/A	49200	\$22.70	49210	\$22.70	49220	\$22.70	49330	\$22.70
Left Burner w/Pilot Bracket 75	27	N/A	N/A	N/A	N/A	N/A	N/A	74403	\$23.80
Right Burner 75	28	N/A	N/A	N/A	N/A	N/A	N/A	74404	\$21.80
Burner w/Pilot Brkt. & Air Adj.	29	74401	\$22.30	74401	\$22.30	74402	\$24.40	N/A	N/A
Pilot Generator, Q313A1014 M.V.	31	70098	\$32.30	70098	\$32.30	70098	\$32.30	70098	\$32.30
Pilot Burner w/Orifice Q350A1271 N.	32	74410	\$9.80	74410	\$9.80	74410	\$9.80	74410	\$9.80
Pilot Burner w/Orifice Q350A1589 LP	32	74415	\$9.80	74415	\$9.80	74415	\$9.80	74415	\$9.80
Mounting Screws, Pilot (2)	33	50107	\$1.20	50107	\$1.20	50107	\$1.20	50107	\$1.20
Pilot Tubing w/Fittings	34	74452	\$7.00	74452	\$7.00	74452	\$7.00	74452	\$7.00
Burner Support, Front	36	24036	\$5.10	24036	\$5.10	24036	\$5.10	24036	\$5.10
Burner Support, Rear	N/A	24038	\$2.60	24038	\$2.60	24430	\$2.90	24627	\$3.40
Manifold	38	74416	\$6.70	74416	\$6.70	74416	\$6.70	74412	\$24.00
Burner Orifice, Natural Gas	39	74390	\$3.40	74406	\$3.40	74407	\$3.40	*74408	\$3.40
Burner Orifice, L.P. Gas	39	74609	\$3.40	74606	\$3.40	74607	\$3.40	*74608	\$3.40
Warning Flag	41	24068	\$9.80	24068	\$9.80	24068	\$9.80	24068	\$9.80
Limit Control 60T11	42	*74306	\$9.30	*74307	\$9.30	*74308	\$9.30	*74309	\$9.30
Wiring Harness	N/A	74320	\$8.40	74321	\$8.70	74322	\$9.50	74323	\$10.00
Piezo Ignitor	43	70050	\$5.60	70050	\$5.60	70050	\$5.60	70050	\$5.60
Ignitor Wire	44	74351	\$5.10	74351	\$5.10	74351	\$5.10	74351	\$5.10
Electrode	45	74350	\$3.70	74350	\$3.70	74350	\$3.70	74350	\$3.70
Bottom Burner Cover	N/A	24039	\$8.20	24039	\$8.20	24431	\$10.40	24628	\$11.70

Mr. Contractor, we only sell parts through our wholesalers, but the prices listed above are for your convenience. For prompt parts service, contact the wholesaler from which you purchased your Cozy heater. **NOTE:** Parts & schematic drawings on current models are shown at www.cozyheaters.com.

Prices and specifications subject to change without notice. All prices are F.O.B. factory.

P/N 74521
*2 Required

MARCH 2005

IMPORTANT SAFETY BULLETIN ON YOUR GAS CONTROL AND PILOT LIGHT SYSTEM FOR HEATING EQUIPMENT

WHAT YOU DON'T KNOW CAN HURT YOU.

Your pilot light system has been designed for safe and reliable operation. Although safety mechanisms are built-in, the potential for hazard exists. This information is intended to help you avoid these hazards.

YOUR GAS CONTROL AND PILOT LIGHT SYSTEM

Your gas control and pilot light system has a safety device whose purpose is to shut-off the gas supply to the appliance if the pilot light goes out. If you have trouble lighting the pilot or keeping it lit, it may mean that this safety device is warning you that there is a problem with your system. Inspection and repairs or replacement must be made by a trained gas service technician.



TAMPERING IS DANGEROUS

The pilot safety system may also not work if you do not follow the lighting instructions carefully or if you tamper with the gas control that you use to light the pilot. Tampering with the gas control, particularly with tools, can damage the safety mechanism in the control and can allow gas to leak. This can result in a fire or explosion causing property damage, personal injury or death.

IF YOU SMELL GAS, DON'T LIGHT IT

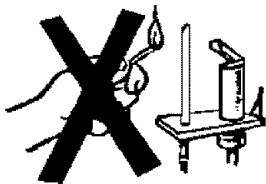

IF YOU CAN'T LIGHT IT,
DON'T FIGHT IT!



THIS IS NOT AN ADVERTISEMENT

WHAT TO DO IF YOU SMELL GAS . . .

- Do not try to light any appliance.
- Do not touch any electrical switch; do not use any phone in your building.
- Immediately call your gas supplier from a neighbor's phone. Follow the gas supplier's instructions.
- If you cannot reach your gas supplier, call the fire department.

Installation and service must be performed by a qualified installer, service agency or the gas supplier.

Do not store or use gasoline or other flammable vapors and liquids in the vicinity of this or any other appliance.

CRITICAL SAFETY POINTS TO REMEMBER . . .

- Your gas has been odorized so that you can smell it. Always smell around for gas before lighting your appliance.
- Sniff for L.P.-gas at floor level. LP-gas is heavier than air and may temporarily exist at floor level.



- If you smell gas, do not attempt to light the pilot. Do not cause a spark by turning on or off electrical switches or appliances or by using the phone. Turn off the gas to the appliances and call your gas supplier from another location.
- If your gas control has gotten wet as the result of flooding or other wetting, it must be replaced immediately by a trained gas service technician. Water can lead to damage of the internal safety mechanism in the gas control and can create a hazardous condition.

LIMITED WARRANTY

The Louisville Tin & Stove Co. warrants to the original user the accompanying product for the period specified herein, provided said product is installed, operated, maintained, serviced, and used according to the instructions and specifications accompanying the product. **AS OUTLINED IN OUR INSTRUCTIONS, ANY WARRANTY CONSIDERATIONS ARE CONTINGENT ON INSTALLATION BY A QUALIFIED INSTALLER (CONTRACTOR). SELF-INSTALLATION IS NOT RECOMMENDED AND MAY INVALIDATE YOUR WARRANTY.**

If within a period of one year from the date of installation of the product, any part supplied by the manufacturer proves to be defective due to workmanship or material, it will replace such part, provided parts have not been subjected to misuse, alteration, neglect, or accidents. The term of the warranty for the heat exchanger is covered in Table A below. Any claim not made within ten (10) days after the expiration of the warranty period shall be deemed waived by the user.

The manufacturer shall have no liability or be required to perform any obligation under this warranty unless, when requested, the user returns, at the user's expense, the component or product claimed defective, to the manufacturer for inspection, to enable the manufacturer to determine if the claimed defect is covered by this warranty.

No charges for freight, labor or other expenses incurred in the repair, removal, or replacement of any product or component claimed to be defective, will be paid by the manufacturer to the user, and the manufacturer will not be liable for any expenses incurred, by the user, in remedying any defect in the product.

Service under this warranty is the responsibility of the installer. In the event service under this warranty is needed, the user of the product shall request such service directly from the installer. If the user is unable to locate the installer, the user should write directly to the manufacturer, and the name of an alternative service source will be supplied.

The product safety registration card (packed inside

the appliance) must be completed and returned to the factory.

THIS WARRANTY IS EXPRESSLY IN LIEU OF ANY OTHER WARRANTIES, EXPRESS OR IMPLIED (WHETHER WRITTEN OR ORAL). ANY IMPLIED WARRANTY OF MERCHANTABILITY OR OF FITNESS FOR A PARTICULAR PURPOSE IS EXPRESSLY LIMITED TO THE DURATION OF THE MANUFACTURER'S EXPRESS, WRITTEN WARRANTY.

UNDER NO CIRCUMSTANCES SHALL THE MANUFACTURER BE LIABLE FOR ANY SPECIAL, INDIRECT OR CONSEQUENTIAL DAMAGES OR EXPENSES ARISING DIRECTLY OR INDIRECTLY FROM ANY COMPONENT OR FROM THE USE THEREOF. THE REMEDIES SET FORTH HEREIN SHALL BE THE EXCLUSIVE REMEDIES AVAILABLE TO THE USER AND ARE IN LIEU OF ALL OTHER REMEDIES.

SOME STATES DO NOT ALLOW LIMITATIONS ON HOW LONG AN IMPLIED WARRANTY LASTS, SO THE ABOVE LIMITATIONS MAY NOT APPLY TO YOU.

SOME STATES DO NOT ALLOW THE EXCLUSION OR LIMITATION OF INCIDENTAL OR CONSEQUENTIAL DAMAGES, SO THE ABOVE LIMITATIONS OR EXCLUSIONS MAY NOT APPLY TO YOU.

THIS WARRANTY GIVES YOU SPECIFIC LEGAL RIGHTS, AND YOU MAY ALSO HAVE OTHER RIGHTS, WHICH VARY, FROM STATE TO STATE.

TABLE A

Warranty for gas appliance heat exchangers only.

<u>Product</u>	<u>Warranty Period</u>
Cozy Gas Fired Floor Furnace	10 Years
Cozy Gas Fired Wall Furnace	10 Years
Cozy Gas Fired Vented Console Heater	10 Years
Cozy Gas Fired Direct Vent Heater	10 Years
Cozy Gas Fired Counterflow Furnace	10 Years
Cozy Gas Fired Counterflow Direct Vent Furnace	10 Years
Cozy Gas Fired Mobile Home Direct Vent Furnace	10 Years
Cozy Gas Fired Hi-Efficient Direct Vent Wall Furnace	10 Years