

Kodak EasyShare DX4530 zoom digital camera

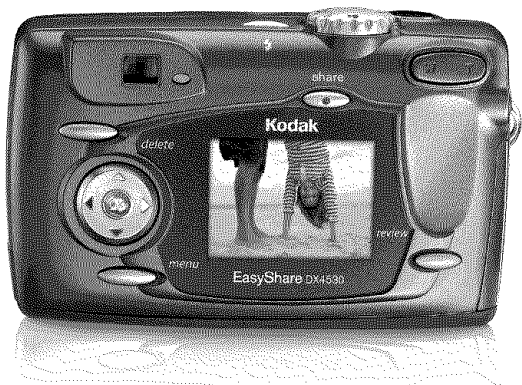

User's Guide

www.kodak.com

For interactive tutorials, www.kodak.com/go/howto



Eastman Kodak Company
343 State Street
Rochester, New York 14650

All screen images are simulated

© Eastman Kodak Company, 2003

Kodak, EasyShare, Max, and Retinar are trademarks of Eastman Kodak Company.

P/N 6B8563

Front View

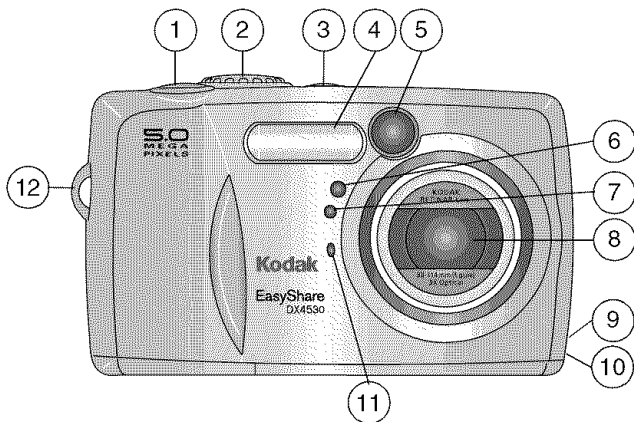

1 Shutter button

2 Mode dial

3 Flash button

4 Flash unit

5 Viewfinder window

6 Self Timer light

7 Light sensor

8 Lens

9 DC In (for optional 3V AC adapter)

10 Lens cap strap post

11 Microphone

12 Wrist strap post

Back View

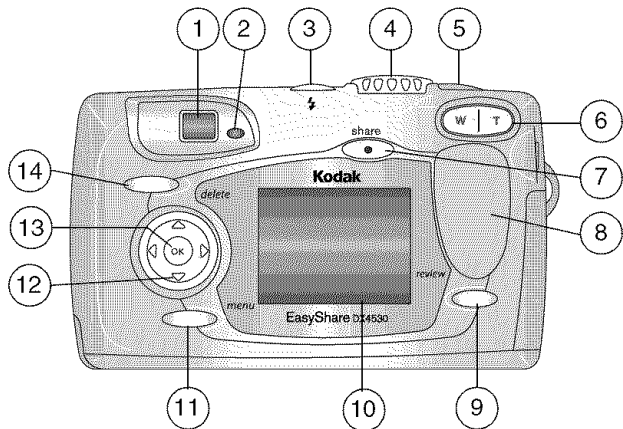

1 Viewfinder

2 Ready light

3 Flash button

4 Mode dial

5 Shutter button

6 Zoom (Wide Angle and Telephoto)

7 Share button

8 Grip

9 Review button

10 Camera screen (LCD)

11 Menu button

12 4-way control 

13 OK button

14 Delete button

Side View

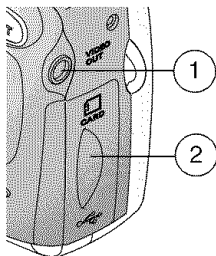

1 Audio/Video Out

2 Door to:

- Slot for optional SD/MMC card
- USB port (for computer connection)

Top, Bottom View

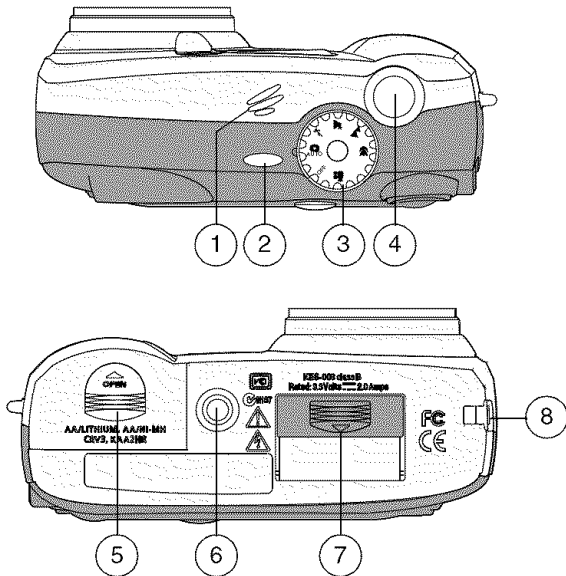

1 Speaker

2 Flash button

3 Mode dial

4 Shutter button

5 Battery door

6 Tripod socket

7 Dock connector door

8 Lens cap strap post



Table of Contents

1	Getting Started	1
	Install Software First.....	1
	Need This User Guide in Larger Print?	1
	What Can I Do With My Camera?.....	2
	What Can I Do With My Pictures and Videos?	2
	Package Contents.....	3
	Attaching the Wrist Strap.....	4
	Attaching the Lens Cap Strap.....	4
	Adding Optional Lenses	4
	Loading the Battery.....	5
	Mode Dial Settings.....	6
	Turning On the Camera.....	7
	Setting the Date and Time	8
	Checking Camera Status Icons	9
	Inserting an SD/MMC Card.....	10
	Choosing Internal Memory or SD/MMC Card.....	11
	Important Battery Information.....	13
2	Taking Pictures	15
	Taking Pictures in Auto Mode.....	15
	Taking Pictures in Sport Mode	16
	Taking Pictures in Night Mode	17



Taking Pictures in Landscape Mode.....	18
Taking Pictures in Close-up Mode.....	19
Liveview—Framing with the Camera Screen.....	20
Quickview—Reviewing the Picture Just Taken.....	21
Using the Auto Focus Framing Marks	22
Using the Optical Zoom.....	23
Using the Digital Zoom.....	23
Using the Flash.....	24
Putting Yourself in the Picture.....	26
Setting Exposure Compensation	27
Setting Long Time Exposure.....	28
Setting Picture Quality.....	29
Placing the Date on Pictures	30
Setting the Orientation Sensor.....	31
3 Taking Videos	33
Taking a Video.....	33
Quickview—Reviewing the Video Just Taken.....	34
Using the Optical Zoom.....	34
Putting Yourself in the Video	35
4 Reviewing Pictures and Videos	37
Viewing Pictures and Videos	37
Playing a Video	38
Deleting Pictures and Videos	38
Review Menus	39
Magnifying Pictures	39

Protecting Pictures and Videos From Deletion.....	40
Running a Slide Show	41
Copying Pictures and Videos.....	43
Displaying Video Date.....	44
Viewing Picture/Video Information	44
5 Tagging Pictures and Videos	45
When Can I Tag My Pictures and Videos?.....	45
Tagging Pictures for Printing.....	46
Tagging Pictures and Videos for Emailing.....	47
Tagging Pictures and Videos as Favorites	48
6 Customizing Your Camera Settings	49
Accessing Setup Mode/Menus.....	49
Setup Menus.....	49
Changing the Print Quantity Default	50
Turning Off Quickview	50
Turning On Liveview In Still Modes	51
Turning Off the Shutter Sound	51
Setting Video Out.....	52
Selecting a Language	52
Formatting Internal Memory or SD/MMC Card	53
Viewing Camera Information	54

7	Installing the Software	55
	Windows System Requirements	55
	Mac OS X System Requirements.....	56
	Mac OS 8.6 and 9.x System Requirements	56
	Install the Software.....	57
8	Connecting to the Computer	59
	Connecting to the Computer.....	59
	Printing Pictures From Your Computer	60
	Printing From an Optional SD/MMC Card	60
	Ordering Prints Online	60
9	Using the Optional Camera Dock II	61
	Camera Dock Package Contents.....	61
	Installing the Camera Insert	62
	Connecting the Camera Dock.....	63
	Installing the Battery in the Camera	64
	Docking the Camera.....	65
	Charging the Battery	66
	Transferring Pictures and Videos	67
	Caution When Using a Tripod.....	67
	Earlier Camera Dock Model.....	68

10	Troubleshooting	69
	Troubleshooting—Camera	69
	Troubleshooting—Camera Dock II	82
11	Getting Help	85
	Helpful Web Links	85
	Help in this Manual	85
	Software Help	85
	Telephone Customer Support	86
12	Appendix	89
	Camera Specifications.....	89
	Original Factory Settings—Camera	91
	Upgrading Your Software and Firmware	92
	Tips, Safety, Maintenance	92
	Storage Capacities.....	93
	Locating Pictures and Videos on a Card	94
	Card File Naming Conventions	94
	Power-Saving Features.....	95
	Optional AC Adapter	95
	Regulatory Information.....	95

1 Getting Started

Install Software First

Install the software from the Kodak EasyShare software CD **before** connecting the camera (or optional camera dock) to the computer. Failure to do so may cause the software to load incorrectly.

See the Quick Start Guide or Installing the Software, page 55.

Need This User Guide in Larger Print?

- 1 See www.kodak.com/go/dx4530support.
- 2 Navigate to the *Manuals* section.
- 3 Click *View as PDF* to open the User's Guide.
- 4 On a Windows OS-based computer or Mac OS 8.6 or 9.x:
 - From the File menu, select Print.
 - In the Print window, select Fit to Page.On Mac OS X:
 - From the File menu, select Page Setup.
 - Change Scale to 200%.
- 5 Print as usual.

What Can I Do With My Camera?

Capture Still Pictures —Use Auto mode to enjoy point-and-shoot operation. Use Sport, Night, Landscape, and Close-up modes to expand your capabilities.

Capture Videos with Sound —Capture videos as QuickTime movies.

Review —Display, protect, and delete pictures and videos; tag for albums.

Share —Share pictures (print, email, save as Favorites) and videos (email, save as Favorites).

Set Up —Customize your camera functions (see page 49).

What Can I Do With My Pictures and Videos?

Install the software from the Kodak EasyShare software CD, then:

Transfer—Transfer pictures and videos to your computer.

Share—Print pictures, order prints online, email pictures and videos.

Print—(see page 60) Print pictures directly to your home printer or Kodak EasyShare printer dock 4000. Order prints online from Ofoto (www.ofoto.com). Or purchase an optional Kodak secure digital (SD) card or multimedia card (MMC) and:

- Automatically print to any printer with an SD/MMC slot
- Make prints at an SD/MMC-capable Kodak picture maker kiosk
www.kodak.com/go/picturemaker
- Take the card to your local photo retailer for professional printing

Organize—Use Favorites to organize and retrieve pictures on a computer.

Edit—Add special effects to your pictures, make a custom slide show, fix red-eye, crop, rotate, and much more.

For details, click the Help button in the Kodak EasyShare software. Some Mac operating systems may support limited Kodak EasyShare software features.

Package Contents

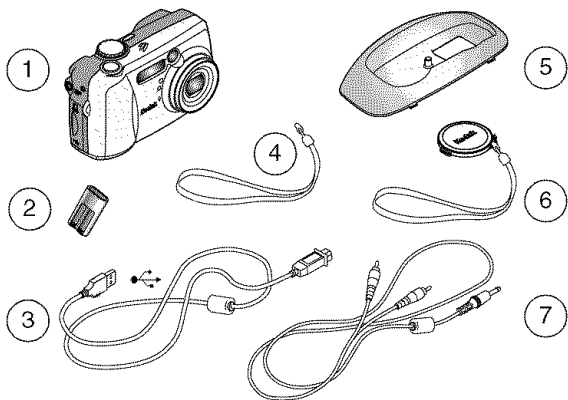

1 Camera

5 Custom camera dock insert (for EasyShare printer dock 4000 or EasyShare camera dock II)

2 CRV3 or equivalent*

6 Lens cap with strap

3 USB cable

7 Audio/Video cable

4 Wrist strap

Not shown: User's Guide, Quick Start Guide, Kodak EasyShare software CD. (In some countries, the User's Guide is provided on a CD only. Contents may change without notice.)

* If your camera was packaged with a Kodak EasyShare camera dock II, a Kodak EasyShare Ni-MH rechargeable battery and AC power adapter are included. For details, see page 61.

Attaching the Wrist Strap

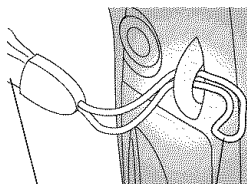

Long
loop

Short
loop

- 1 Thread the wrist strap as shown.
- 2 Thread the long loop through the short loop. Pull until secure.

Attaching the Lens Cap Strap

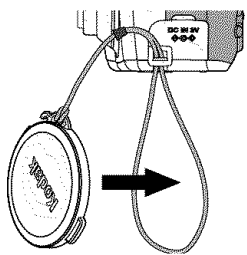

- 1 Thread the lens cap string through the lens cap strap post.
- 2 Thread the lens cap through the loop. Pull until secure.

Use the lens cap to protect the lens when camera is not in use.

Adding Optional Lenses

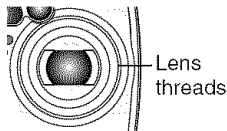

Lens
threads

Lenses are available. Purchase accessories at a dealer of Kodak products. See www.kodak.com/go/dx4530accessories

Loading the Battery

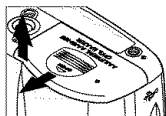

- 1 Turn the Mode dial to Off.
- 2 On the bottom of the camera, slide the battery door and lift to open.

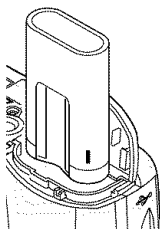

CRV3

- 3 Insert the CRV3 battery as shown.
- 4 Close the battery door.

Important Battery Information

The CRV3 battery is **not** rechargeable.

For acceptable battery life, and to make sure your camera operates dependably, **do not use alkaline batteries.**

NOTE: If AA batteries were included with your camera, insert them as shown.

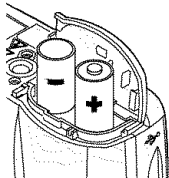

AA





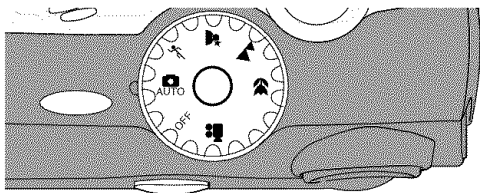

See page 13 for other types of batteries you can use in your camera.

If you purchased the Kodak EasyShare camera dock II, see page 64 for details on installing the Kodak EasyShare Ni-MH rechargeable battery.

See page 95 for information on the optional Kodak 3-volt digital camera AC adapter.

Mode Dial Settings



Icon	Mode	Purpose
Off	Off	Turns off the camera.
	Auto	For general picture-taking. Automatically sets exposure and focus. Flash fires if needed.
	Sport	For subjects that are in motion. Shutter speed is fast. Flash fires if needed.
	Night	For night scenes or low light conditions. Captures close and background subjects. Flash fires if needed. In dark scenes, the shutter speed is set between 1/30 and 1/2 second. Place camera on a flat, steady surface or tripod to avoid camera shake.
	Landscape	For distant subjects. Flash does not fire unless you turn it on.*
	Close-up	For subjects 2.8 to 28 in. (7 to 70 cm) from the lens in wide angle, or 11 to 28 in. (28 to 70 cm) in telephoto. Flash does not fire.
	Video	Captures video with sound. Flash does not fire.

* To turn on the flash, see page 24.

Turning On the Camera

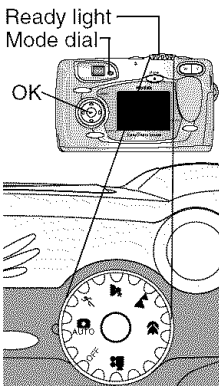

- 1 Remove the lens cap.

If you do not remove the lens cap, it comes off automatically when you turn on the camera.

- 2 Turn the Mode dial from Off to any other position.

The ready light blinks green while the camera performs a self-check.

When the ready light glows steady green, the camera is ready to take pictures (or videos, if the mode dial is set to ).

In Still and Video modes, a status area appears on the camera screen.

Changing the Display

To	Do This
Turn Liveview on so that the camera screen can be used as a viewfinder	Press the OK button. To turn it off, press the OK button again.
Change the Liveview setting so that it is on whenever the camera is on	See page 51.
Turn the status area back on after it times out	Press  .
Turn off the camera	<ol style="list-style-type: none"> 1 Turn the Mode dial to Off. <i>The camera completes operations that are in process.</i> 2 Replace the lens cap.

Setting the Date and Time

Setting the Date & Time, First Time

The *Date and Time have been reset* message appears the first time you turn on the camera or if the battery is removed for an extended time.

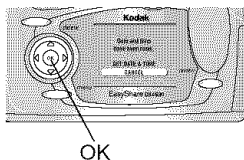

- 1 SET DATE & TIME is highlighted. Press the OK button.

(Select Cancel to set the date and time at a later time.)

The Date & Time screen appears.

- 2 Go to step 4 below, Setting the Date & Time, Anytime.

Setting the Date & Time, Anytime

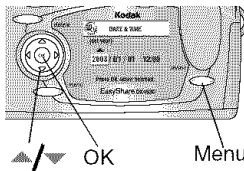

- 1 Turn on the camera. Press the Menu button.
- 2 Press ▲/▼ to highlight Setup, then press the OK button.
- 3 Press ▲/▼ to highlight Date & Time, then press the OK button.

The date format is YYYY/MM/DD. The time is displayed in a 24-hour format.

- 4 Press ▲/▼ to adjust the date and time. Press ◀/▶ to advance to the next setting.
- 5 When finished, press the OK button.
- 6 Press the Menu button to exit the menu.

The setting remains until you change it.

NOTE: Depending on your computer operating system, Kodak EasyShare software may allow your computer to automatically update the camera clock when you connect the camera. See the Kodak EasyShare software Help for details.

Checking Camera Status Icons



Status
Icons

Screen
Icon

To check the current camera settings, turn the Mode dial from Off to any mode.

For flash icons, see page 24.

For Share icons, see page 45.

Status Icons (Top of Camera Screen)

Status icons depict enabled features and settings:

	LT			
Date stamp	Long time exposure	Exposure compensation	Self Timer	Flash mode

<ul style="list-style-type: none"> ★★★ Best ★★★ Best (3:2) ★★ Better ★ Good 	015	<ul style="list-style-type: none"> Internal memory Memory Card
Quality	Pictures remaining	Current Storage location

Screen Icons (Bottom of Camera Screen)

Screen icons depict the current mode or a battery concern:

Auto	Sport	Night	Landscape	Close-up	Review	Video

Share		
Share	Low battery	Exhausted battery (blinking)

Inserting an SD/MMC Card

Your camera has 32 MB of internal storage for pictures and videos. Optional SD/MMC cards provide removable, reusable storage.



CAUTION:

The card can only be inserted one way; forcing it may damage the camera or card.

Do not insert or remove a card when the green ready light is blinking; doing so may damage your pictures, card, or camera.

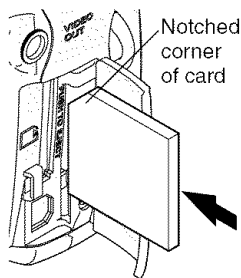

To insert an SD/MMC card:

- 1 Turn off the camera.
- 2 Open the card door.
- 3 Orient the card as shown.
- 4 Push the card into the slot to seat the connector.
- 5 Close the door.

To remove the card, push it in, then release it. When the card is partially ejected, pull it out.

See page 93 for storage capacities. Purchase accessories at a dealer of Kodak products. See www.kodak.com/go/dx4530accessories

Choosing Internal Memory or SD/MMC Card

The camera offers two options for storing pictures and videos:

Internal Memory  —store pictures and videos in internal memory.



SD/MMC Card  —store as many pictures and videos as you like, depending on the size of the card. Purchase accessories at a dealer of Kodak products. See www.kodak.com/go/dx4530accessories. For storage capacities, see page 93.

Managing Your Storage Location Setting

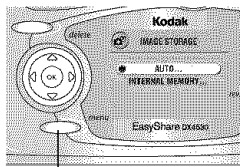
- 1 Turn on the camera.
- 2 Press the Menu button.
- 3 Press / to highlight Image Storage , then press the OK button.



Menu

- 4 Press / to highlight an option, then press the OK button:

Auto (default)—the camera uses the card if one is in the camera. If not, the camera uses internal memory.

Internal Memory—the camera always uses internal memory, even if a card is installed.

- 5 Highlight Continue, then press the OK button again.

The setting remains until you change it and applies to all camera functions.



- 6 Press the Menu button to exit the menu.

Checking Your Storage Setting

In **Still and Video modes**, the storage location icon that appears in the status area indicates the camera's storage location. To check the location, either:

Picture or
video location



- Turn the Mode dial from the Off position, or
 - In any capture mode, press  .
-  —Memory Card
-  —Internal Memory



Checking a Picture or Video's Location

In **Review mode**, the storage location icon that appears with a picture indicates the location of the picture or video and the camera setting.

Picture or
video location



Press the Review button.

-  —Picture or video is stored on a card
-  —Picture or video is stored in internal memory

Important Battery Information

Choose the replacement battery that fits your needs—and get the best performance.

Kodak Battery Replacement Types/Battery Life

Your camera can use the following types of batteries. Actual battery life may vary based on usage.

CRV3 lithium battery
(included with camera)

AA (2) lithium batteries

Ni-MH rechargeable
battery pack* (per charge)

AA (2) Ni-MH rechargeable
batteries (per charge)

Kodak Max digital
camera batteries, AA (2)

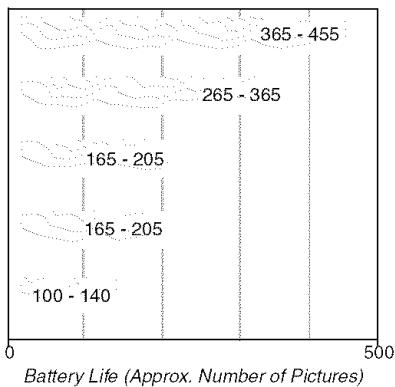

* Included with the Kodak EasyShare camera dock II and printer dock 4000

We do not recommend or support alkaline batteries. For acceptable battery life, and to make sure your camera operates dependably, use the replacement batteries listed above.

For information on batteries, see www.kodak.com/global/en/service/batteries/batteryUsage.jhtml

Extending Battery Life

- Limit the following activities that quickly deplete battery power:
 - Reviewing your pictures on the camera screen (see page 37)
 - Using Liveview (see page 20)
 - Using Quickview (see page 21 and page 34).
 - Excessive use of the flash
- Purchase an optional Kodak 3-volt AC adapter to power your camera (see page 95).
- Purchase an optional Kodak EasyShare camera dock II (see page 61). The camera dock II powers your camera, transfers pictures, and is a battery charger for its included Kodak EasyShare Ni-MH rechargeable battery pack.
- Purchase an optional Kodak EasyShare printer dock 4000 (see page 61). The printer dock 4000 powers your camera, makes 4 x 6 prints with or without a computer, transfers pictures, and is also a battery charger for its included Kodak EasyShare Ni-MH rechargeable battery pack.
- Dirt on the battery contacts can affect battery life. Wipe the contacts with a clean, dry cloth before loading batteries in the camera.
- Battery performance is reduced at temperatures below 41° F (5° C). Carry spare batteries when using your camera in cold weather, and keep them warm. Do not discard cold batteries that do not work; when they return to room temperature, they may be usable.

Battery Safety and Handling

- Do not allow batteries to touch metal objects, including coins. Otherwise, a battery may short circuit, discharge energy, become hot, or leak.
- For rechargeable battery disposal information, see the Rechargeable Battery Recycling Corporation Web site at www.rbrc.com.

2 Taking Pictures

The camera is ready to take pictures when you turn it on—even if you are in Review, Share, or Setup. (In Video mode, the camera captures video.) Before you take a picture, make sure your picture storage location is set the way you want it (see page 11).

Taking Pictures in Auto Mode

Use Auto for general picture-taking. Exposure, focus, and flash are automatic.

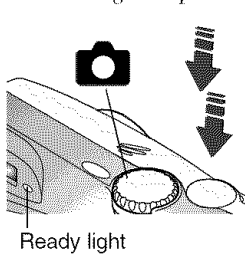

- 1 Turn the Mode dial to .
The camera screen displays a mode description. To interrupt it, press ▼.
- 2 Use the viewfinder or camera screen to frame your subject. (To turn the camera screen on or off, press the OK button.)
- 3 Press the Shutter button **half-way** to set the exposure and focus. (Otherwise, the picture could be too dark, light, or blurry.)
- 4 When the ready light glows green, continue pressing the Shutter button **completely down** to take the picture.



The ready light blinks green while the picture is saved. The ready light blinks orange while the flash is recharging (or if there is an auto-exposure or auto-focus error).

Default flash setting:	Auto or Red-eye
Available flash settings:	Auto, Flash Off, Fill Flash, Red-eye
Camera returns to default:	When you change modes or turn off the camera.

Taking Pictures in Sport Mode

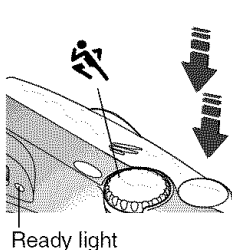
Use this mode when the subject is in motion. In Sports mode, the shutter speed is set between 1/30 to 1/1700 second.



- 1 Turn the Mode dial to .
The camera screen displays a mode description for a few seconds. To interrupt the description, press .
- 2 Press the Shutter button **half-way** to set the exposure and focus.
- 3 When the ready light glows green, continue pressing the Shutter button **completely down** to take the picture.
The ready light blinks green while the picture is saved.

Default flash setting:	Auto
Available flash settings:	Auto, Flash Off, Fill Flash, Red-eye
Camera returns to default:	When you change modes or turn off the camera.

Taking Pictures in Night Mode

Use this mode for night scenes or low light conditions. The flash illuminates close subjects. A longer exposure captures more detail of background subjects. The shutter speed is set between 1/30 to 1/2 second, depending on available light.

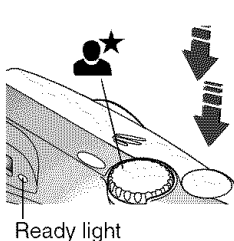

1 To avoid blurry pictures, place the camera on a flat, steady surface or use a tripod.

2 Turn the Mode dial to .

The camera screen displays a mode description for a few seconds. To interrupt the description, press .

3 Press the Shutter button **half-way** to set the exposure and focus.

4 When the ready light glows green, continue pressing the Shutter button **completely down** to take the picture.

The ready light blinks green while the picture is saved.

Default flash setting:	Auto
Available flash settings:	Auto, Flash Off, Fill Flash, Red-eye
Camera returns to default:	When you change modes or turn off the camera.

Taking Pictures in Landscape Mode

Use this mode to capture subjects further than 57.4 ft (17.5 m), such as landscape scenes. The shutter speed is set between 1/8 to 1/1700 second.

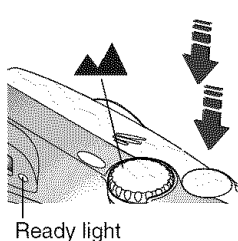

- 1 Turn the Mode dial to .
The camera screen displays a mode description for a few seconds. To interrupt the description, press .
- 2 Press the Shutter button **half-way** to set the exposure.
- 3 When the ready light glows green, continue pressing the Shutter button **completely down** to take the picture.
The ready light blinks green while the picture is saved.

Default flash setting:	Off
Available flash settings:	Auto, Flash Off, Fill Flash, Red-eye
Camera returns to default:	When you change modes or turn off the camera.



Taking Pictures in Close-up Mode

Use this mode to capture subjects this close to the lens:

- Wide angle: 2.8 to 28 in. (7 to 70 cm)
- Telephoto: 11 to 28 in. (28 to 70 cm)

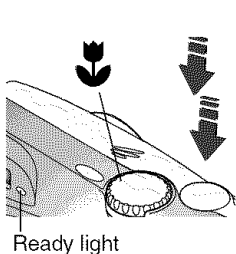
The shutter speed is set between 1/8 to 1/1700 second.



- 1 Turn the Mode dial to  .
The camera screen displays a mode description for a few seconds. To interrupt the description, press  .
- 2 Press the Shutter button **half-way** to set the exposure and focus.
- 3 When the ready light glows green, continue pressing the Shutter button **completely down** to take the picture.
The ready light blinks green while the picture is saved.

Default flash setting:	Off
Available flash settings:	Auto, Flash Off, Fill Flash, Red-eye
Camera returns to default:	When you change modes or turn off the camera.

Liveview—Framing with the Camera Screen

When you turn on Liveview, the camera screen displays a live image of what the lens sees. Use the camera screen to frame your subject.

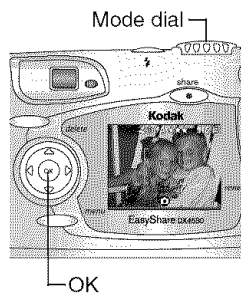

- 1 Turn the Mode dial to any Still position.
The camera screen displays a mode description for a few seconds. To interrupt the description, press ▼.
- 2 Press the OK button to turn on Liveview.
- 3 Frame your subject in the camera screen.
- 4 Press the Shutter button **half-way** to set the exposure and focus, then continue pressing **completely down** to take the picture.
- 5 To turn off Liveview, press the OK button.

NOTE: Liveview quickly depletes battery power. To conserve battery power, turn off Liveview and use the Viewfinder to frame your subject.

To change the Liveview setting so that it is on whenever the camera is on, see page 51.

Using the Viewfinder

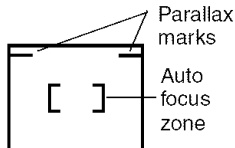

When using the viewfinder to capture close subjects (3 feet or less), keep the subject below the parallax marks. For even more accurate framing results, turn on Liveview. (Liveview depicts what the lens “sees.”)

Quickview—Reviewing the Picture Just Taken

After you take a picture, the camera screen displays a Quickview of that picture for approximately 5 seconds. While the picture is displayed, you can:

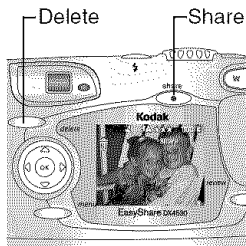

- **Review it:** If you take no action, the picture is saved.
- **Share it:** Press the Share button to tag the picture for print, email, or as a Favorite. (See Tagging Pictures and Videos, page 45.)
- **Delete it:** Press the Delete button while the picture and  are displayed.





To save battery power, you can turn off the Quickview feature. (See page 50.)

Using the Auto Focus Framing Marks

For the best possible pictures, the camera attempts to focus on foreground subjects (even if the subjects are not centered in the scene).

NOTE: Auto Focus framing marks appear only when the camera screen is turned on. The framing marks do not appear in Landscape mode.

- 1 In any Still mode (except Landscape), press the OK button.
The camera screen turns on.
- 2 Press the Shutter button **half-way** to set the exposure and focus.
- 3 The Auto Focus framing marks depict the main focus area or areas. If the camera is not focusing on the desired subject, release your finger, recompose the scene, and repeat Step 2.

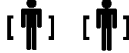
While Shutter Button is Pressed Half-way	
	Center focus
	Center wide focus
	Side focus
	Center and side focus
	Left and right focus

- 4 Continue pressing the Shutter button **completely down** to take the picture.

Using the Optical Zoom

Use optical zoom to get up to 3X closer to your subject. When you turn on the camera, the lens extends to the Wide Angle position. Optical zoom is effective when the lens is no closer than 24 in. (0.6 m) to the subject. When using optical zoom in Close-up mode, stay at least 11 in. (28 cm) from the subject.

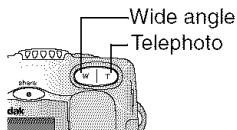

- 1 Use the viewfinder or camera screen to frame your subject.
- 2 Press the Telephoto (T) button to zoom in. Press Wide Angle (W) button to zoom out.

The lens extends or retracts. The viewfinder or camera screen displays the zoomed image.

- 3 Press the Shutter button **half-way** to set the exposure and focus, then **continue pressing completely down** to take the picture.

NOTE: The lens retracts when the camera is turned off.

Using the Digital Zoom

Use Digital Zoom to get an additional 3.3X magnification beyond Optical Zoom.

IMPORTANT: *You may notice a decrease in printed image quality when using Digital Zoom.*

- 1 Press the OK button to turn on Liveview.
- 2 Press the Telephoto (T) button to the Optical Zoom limit. Release the button, then press it again.

The camera screen displays the zoomed image and the magnification level.

- 3 Press the Shutter button **half-way** to set the exposure and focus, then continue pressing **completely down** to take the picture.

Using the Flash

Use the flash when you take pictures at night, indoors, or outdoors in heavy shadows. You can change the flash setting in any Still mode; the default flash setting is restored when you exit the mode or turn off the camera.

Flash Range

- Wide angle: 2 to 11.2 ft (0.6 to 3.4 m)
- Telephoto: 2 to 6.6 ft (0.6 to 2.0 m)

Turning On The Flash

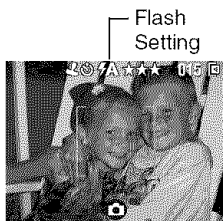

- 1 Press the  button repeatedly to scroll through the flash options.
- 2 Press the OK button.

The flash icon that is displayed on the camera screen status bar (page 9) is the active option.



Auto Flash—flash fires when the lighting conditions require it.



Off—flash never fires.









Fill—flash fires every time you take a picture, regardless of the lighting conditions.



Red-eye—flash fires once so the subject's eyes become accustomed to the flash, then fires again when the picture is taken. (If the lighting conditions require flash but do not require Red-eye reduction, the flash may fire only once.)

Flash Settings In Each Mode

Icon	Mode	Default Flash Setting	Available Flash Settings	Camera Returns to the Default Flash Setting
	Auto	Auto or Red-eye	Auto, Flash Off, Fill Flash, Red-eye	When you change modes or turn off the camera
	Sport	Auto		
	Night	Auto		
	Landscape	Off		
	Close-up	Off		
LT	Long Time Exposure	Off		
	Video	Off	None	Flash cannot be turned on

Other Flash Screen Information



When choosing a flash setting, the current camera settings are displayed in the bottom portion of the screen.

Putting Yourself in the Picture

The Self Timer creates a 10-second delay between the time you press the Shutter button and the time the picture is taken.

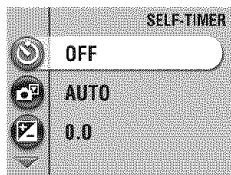

Turn on the Self Timer:

- 1 In any Still mode, press the Menu button.
- 2 Press $\blacktriangle/\blacktriangledown$ to highlight Self Timer , then press the OK button.
- 3 Press $\blacktriangle/\blacktriangledown$ to highlight On, then press the OK button.
- 4 Press the Menu button to exit the menu.

Take the picture:

- 1 Place the camera on a flat surface or use a tripod.
- 2 Compose the scene. Press the Shutter button *half-way* to set the exposure and focus, then continue pressing *completely down*. Move into the scene.

The red Self Timer light blinks slowly for 8 seconds (then quickly for 2 seconds) before the picture is taken.

The Self Timer turns off after the picture is taken or if you change modes.

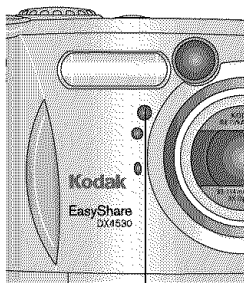

Self Timer
light

Setting Exposure Compensation

Use Exposure Compensation to control how much light enters the camera. This setting is useful for taking pictures in very large rooms, under low light, without a flash.

Adjust the exposure by plus or minus 2 steps in 1/2-step increments.

NOTE: Exposure Compensation cannot be used with Long Time Exposure.

- 1 In any Still mode, press the Menu button.
- 2 Press $\blacktriangle/\blacktriangledown$ to highlight Exposure Compensation , then press the OK button.



- 3 Press $\blacktriangle/\blacktriangledown$ to select the Exposure Compensation setting.
 - If pictures are too light, decrease the value.
 - If pictures are too dark, increase the value.
- 4 Press the OK button to accept the change.
- 5 Press the Menu button to exit the menu.
- 6 Use the camera screen to frame your subject. Press the Shutter button **half-way** to set the focus, then continue pressing **completely down** to take the picture.

This setting remains until you change the Mode dial or turn off the camera.

Setting Long Time Exposure

Use Long Time Exposure to control how long the shutter stays open. Settings are: None, 0.7, 1, 1.5, 2, 3, and 4 seconds.

NOTE: Long Time Exposure cannot be used with Exposure Compensation.

- 1 To avoid blurry pictures, place the camera on a flat, steady surface or use a tripod.
- 2 In any Still mode, press the Menu button.
- 3 Press $\blacktriangle/\blacktriangledown$ to highlight Long Time Exposure **LT**, then press the OK button.

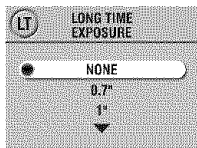

- 4 Press $\blacktriangle/\blacktriangledown$ to highlight an option.
- 5 Press the OK button to accept the change.
- 6 Press the Menu button to exit the menu.
- 7 Use the camera screen to frame your subject. Press the Shutter button *half-way* to set the focus, then continue pressing *completely down* to take the picture.

This setting remains until you change the Mode dial or turn off the camera.

Available flash settings:	Auto, Flash Off, Fill Flash, Red-eye
Default flash setting:	Off
Camera returns to default:	When you change the mode dial or turn off the camera.

Setting Picture Quality

Use the Quality setting to select a picture resolution.

1 In any Still mode, press the Menu button.

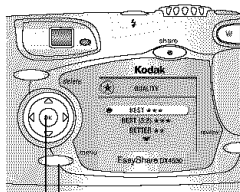

2 Press $\blacktriangle/\blacktriangledown$ to highlight Quality \star , then press the OK button.

3 Press $\blacktriangle/\blacktriangledown$ to highlight an option:

Best $\star\star\star$ (5.0 MP)—for printing up to 20 x 30 in. (50 x 75 cm); pictures are highest resolution and largest file size.

$\star\star\star$ appears on the status bar.

Best (3:2) $\star\star\star$ (4.5 MP)—for printing up to 20 x 30 in. (50 x 75 cm); ideal for printing to the Kodak EasyShare printer dock 4000 and other printing solutions; optimal setting for 4 x 6 in. (10 x 15 cm) prints.

$\star\star\star$ appears on the status bar.

Better $\star\star$ (3 MP)—for printing up to 11 x 14 in. (28 x 36 cm); pictures are medium resolution with smaller file size.

$\star\star$ appears on the status bar.

Good \star (1.2 MP)—for emailing or screen display; pictures are lowest resolution and smallest file size.

\star appears on the status bar.

4 Press the OK button.

5 Press the Menu button to exit the menu.

This setting remains until you change it.

Placing the Date on Pictures

Use the Date Stamp setting to imprint the date on your pictures.

- 1 Make sure the camera clock is set to the correct date (page 8).
- 2 In any Still mode, press the Menu button.
- 3 Press $\blacktriangle/\blacktriangledown$ to highlight Date Stamp , then press the OK button.

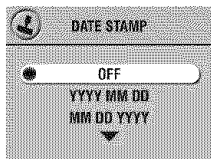

- 4 Press $\blacktriangle/\blacktriangledown$ to highlight an option, then press the OK button.
- 5 Press the Menu button to exit the menu.

The current date is printed in the bottom right corner of new pictures. This setting remains until you change it.

Setting the Orientation Sensor

If you rotate the camera to take a picture (for example, a portrait shot), the Orientation Sensor rotates the picture so that it is displayed correct side up during Quickview and Review.

The Orientation Sensor is turned on as the default. You can turn it off so that pictures are displayed in their original orientation.

NOTE: When your subject is above or below you (such as pictures of an object in the sky, on the ground, or when pointing down at small objects on a table), turn off the Orientation Sensor so that pictures are not rotated unnecessarily.

- 1 In any Still mode, press the Menu button.
- 2 Press $\blacktriangle/\blacktriangledown$ to highlight Orientation Sensor , then press the OK button.

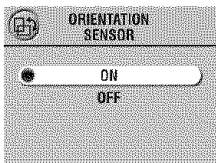

- 3 Press $\blacktriangle/\blacktriangledown$ to highlight On or Off, then press the OK button.
- 4 Press the Menu button to exit the menu.

This setting remains until you change it.

3 Taking Videos

Use the Video mode  to take videos or to customize video-taking settings. Before you take a video, make sure your picture storage location is set the way you want it (see page 11).

NOTE: Zoom and flash are not available in Video mode.

Taking a Video

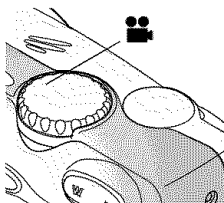

- 1 Turn the Mode dial to Video .

A live image, the status bar, and the approximate recording time available appear on the camera screen.

- 2 Use the viewfinder or camera screen to frame your subject.

NOTE: To conserve battery power, press the OK button to turn off the camera screen.

- 3 Press the Shutter button using the method that you prefer:
 - **Press and release**—press the Shutter button completely down and release within 2 seconds. Press the Shutter button again to stop recording.
 - **Press and hold**—continue pressing and holding the Shutter button completely down. Release the Shutter button to stop recording.

The ready light blinks green and the red Self Timer light glows red while the camera is recording. Recording stops when you release the shutter button or when the current storage location is full.



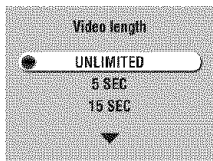
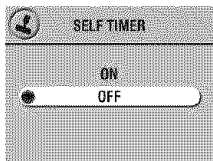

NOTE: See page 93 for video storage capacities.

Putting Yourself in the Video

The Self Timer creates a 10-second delay between the time you press the Shutter button and the time video recording begins.



Turn on the Self Timer:

- 1 Turn the Mode dial to Video , then press the Menu button.
- 2 Press  to highlight Self Timer , then press the OK button.
- 3 Press  to highlight On, then press the OK button.
- 4 Press  to highlight an option, then press the OK button:

Unlimited—records until you stop recording or until storage is full.

Seconds—records for the specified time or until storage is full.

- 5 Press the OK button to return to the menu.
- 6 Press the Menu button to exit the menu.

NOTE: If the current storage location does not have adequate space, some video length options are not displayed. See page 93 for video storage capacities.

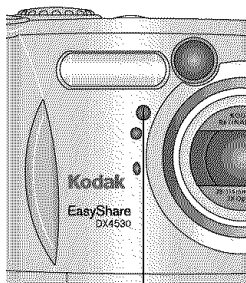

Self Timer
light

Take the video:

- 1 Place the camera on a flat surface or use a tripod.
- 2 Compose the scene, then press the Shutter button completely down. Move into the scene.

The red Self Timer light blinks slowly for 8 seconds, quickly for 2 seconds, then stays on while the video is recording.

- 3 To stop recording before the specified time, press the Shutter button.

The Self Timer turns off after you take the video.

4 Reviewing Pictures and Videos

Press the Review button to view and work with pictures and videos that are stored in internal memory or on a card. Remember, press the Shutter button to take a picture anytime, even in Review.

Viewing Pictures and Videos

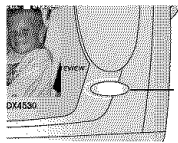

- 1 Press the Review button.

The camera screen displays the last picture or video taken.

*The icons displayed with each picture indicate the applied features. See *Checking Camera Status Icons*, page 9.*

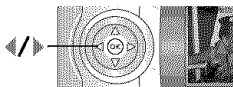

- 2 Press to scroll backward or forward through pictures and videos. (For fast scrolling, press and hold . Fast-scrolling images appear in the center of the screen.)

- 3 Press the Review button to exit Review.

NOTE: Pictures taken at the Best (3:2) quality setting are displayed at a 3:2 aspect ratio, as shown, with a black bar at the top of the screen.



Playing a Video

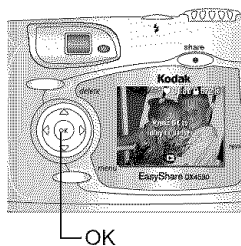

- To play a video, press the OK button. To pause, press the OK button during playback.
- To adjust the volume, press ▲/▼ during playback.
- To rewind a video, press ◀ during playback. To play the video, press the OK button.
- To go to the previous or next picture or video, press ◀/▶ while no video is playing.

Deleting Pictures and Videos

- 1 Press the Review button.
- 2 Press ◀/▶ to locate a picture or video, then press the Delete button.

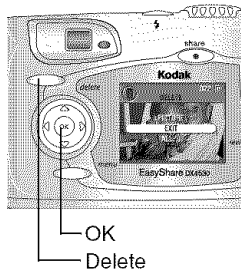

- 3 Press ▲/▼ to highlight an option, then press the OK button:

PICTURE or VIDEO—deletes the displayed picture or video.









EXIT—exits the Delete screen.

ALL—deletes all pictures and videos from your current storage location.

NOTE: Protected pictures and videos cannot be deleted in this manner. Remove protection before deleting (see page 40).

- 4 After deleting, press ◀/▶ to stay in delete mode and scroll to different pictures and videos. To exit Delete, press the Delete button.

Review Menus

	Magnify (page 39)		Copy (page 43)
	Protect (page 40)		Video Date Display (page 44)
	Image Storage (page 11)		Picture Info (page 44)
	Slide Show (page 41)		Setup Menu (page 49)

Magnifying Pictures







Use the Magnify feature to zoom in to different areas of a picture.

- 1 Press the Review button, then locate a picture.



- 2 To magnify at 2X, press the OK button. (Or press the Menu button, highlight Magnify, then press the OK button.) To magnify at 4X, press the OK button again.

The picture is magnified. The Magnify icon  and the magnification value are displayed.

- 3 Press  /   /  to navigate to different parts of the picture.
- 4 Press the OK button to redisplay the picture at the 1X (original) size.
- 5 Press  /  to locate a different picture, or press the Review button to exit Review mode.

Protecting Pictures and Videos From Deletion

- 1 Press the Review button, then locate the picture or video to protect.
- 2 Press the Menu button.

Protect icon



- 3 Press $\blacktriangle/\blacktriangledown$ to highlight Protect , then press the OK button.

The picture or video is protected and cannot be deleted. The Protect icon  appears with the protected picture or video.

- 4 To remove protection, press the OK button again.
- 5 Press the Menu button to exit the menu.





CAUTION:

Formatting internal memory or SD/MMC card deletes all (including protected) pictures, videos, and email addresses.

Running a Slide Show

Use the Slide Show to display your pictures and videos on the camera screen. To run a slide show on a television or on any external device, see page 42.

Starting the Slide Show

- 1 Press the Review button, then press the Menu button.
- 2 Press  to highlight Slide Show , then press the OK button.

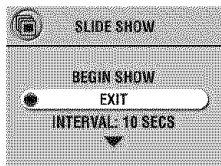

- 3 Press  to highlight Begin Show, then press the OK button.



Each picture and video is displayed once, in the order in which you took them. Then the camera returns to the menu.

- 4 To cancel the Slide Show, press the OK button.

Changing the Slide Show Display Interval

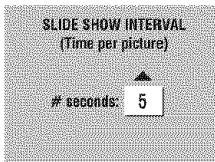
The default interval setting displays each picture for 5 seconds. You can increase the display interval to up to 60 seconds.



- 1 On the Slide Show menu, press  to highlight Interval, then press the OK button.
- 2 Select a display interval. To scroll through the seconds quickly, press and hold .
- 3 Press the OK button.

The interval setting remains until you change it.

Running a Continuous Slide Show Loop

When you turn on Loop, the slide show is continuously repeated.

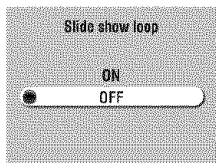

- 1 On the Slide Show menu, press ▲/▼ to highlight Loop, then press the OK button.
- 2 Press ▲/▼ to highlight On, then press the OK button.

When you start a slide show, it repeats until you cancel it by pressing the OK button or until battery power is exhausted. The Loop setting remains until you change it.

Displaying Pictures and Videos on a Television

You can display pictures and videos on a television, computer monitor, or any device equipped with a video input. (Image quality on a television screen may not be as good as on a computer monitor or when printed.)

NOTE: Ensure that the Video Out setting (NTSC or PAL) is correct (see page 52).

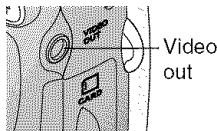

- 1 Connect the audio/video cable (included) from the camera video-out port to the television video-in port (yellow) and audio-in port (white). Refer to your television user's guide for details.
The camera screen turns off; the television screen acts as the camera display.
- 2 Review pictures and videos on the television screen.

NOTE: The slide show stops if you connect or disconnect the cable while a slide show is running.

Copying Pictures and Videos

You can copy pictures and videos from a card to internal memory or from internal memory to a card.

Before you copy, make sure that:

- A card is inserted in the camera.
- The camera's picture storage location is set to the location **from** which you are copying. See Choosing Internal Memory or SD/MMC Card, page 11.

Copy pictures or videos:

- 1 Press the Review button, then press the Menu button.
- 2 Press $\blacktriangle/\blacktriangledown$ to highlight Copy \blacktriangleright , then press the OK button.



- 3 Press $\blacktriangle/\blacktriangledown$ to highlight an option:
 - PICTURE or VIDEO**—copies the current picture or video.
 - EXIT**—returns to the Copy screen.
 - ALL**—copies all pictures and videos from your selected storage location to the other location.

- 4 Press the OK button.

A progress bar monitors the copy process until copy is complete. (For information on picture numbering, see page 94.)

NOTE:

- Pictures and videos are copied, not moved. To remove pictures and videos from the original location after they are copied, delete them (see page 38).
- Tags that you applied for print, email, and Favorites are not copied. Protection settings are not copied. To apply protection to a picture or video, see page 40.

Displaying Video Date

To display the capture date and time (only during video playback on the camera):

- 1 Press the Review button, then press the Menu button.
- 2 Press $\blacktriangle/\blacktriangledown$ to highlight Video Date Display, then press the OK button.



- 3 Press $\blacktriangle/\blacktriangledown$ to highlight an option, then press the OK button.
- 4 Press the Menu button to exit the menu.

The capture date and time appear during video playback on the camera. This setting remains until you change it.

Viewing Picture/Video Information

- 1 Press the Review button, then press the Menu button.
- 2 Press $\blacktriangle/\blacktriangledown$ to highlight About, then press the OK button.



Information about the picture or video is displayed.

- 3 To view information on the next or previous picture or video, press $\blacktriangle/\blacktriangleright$. Press the Menu button to exit the menu.

5 Tagging Pictures and Videos





The Share button lets you “tag” your pictures and videos. When they are transferred to your computer, you can share:

Tagged Pictures

- By print
- By email
- As Favorites, for easy organization on your computer

Tagged Videos

- By email
- As Favorites

		Print (page 46)
		Email (page 47)
		Favorite (page 48)

When Can I Tag My Pictures and Videos?

Press the Share button to tag pictures and videos:

- Just after you take them, during Quickview (see page 21 and page 34)
- After pressing the Review button (see page 37)

NOTE: Tags remain until removed. If a tagged picture or video is copied, the tag is **not** copied. For details on organizing, printing, or emailing, click the Help button in the Kodak EasyShare software.

Tagging Pictures for Printing

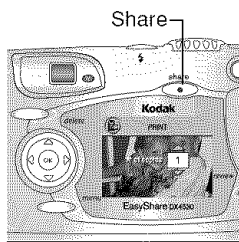

- 1 Press the Review button, then locate a picture.
- 2 Press the Share button. Press $\blacktriangle/\blacktriangledown$ to highlight Print , then press the OK button.*
- 3 Press $\blacktriangle/\blacktriangledown$ to select the number of copies (0-99). Zero removes the tag for that picture.
- 4 Press the OK button. Press the Share button to exit the Share menu.

The Print icon  appears on the status bar. The default quantity is one. (To change the default, see page 50.)

* To tag all pictures in the storage location, highlight Print All, press the OK button, then indicate the number of copies as described above. Print All is not available in Quickview.

To remove the print tagging for all pictures in the storage location, highlight Cancel Prints, then press the OK button. Cancel Prints is not available in Quickview.

Printing Tagged Pictures

To print digital pictures, see page 60.

Tagging Pictures and Videos for Emailing

First, use Kodak EasyShare software to create an email address book on your computer. Then, copy up to 32 email addresses to the camera's internal memory. See the Quick Start Guide or Kodak EasyShare software Help for details.

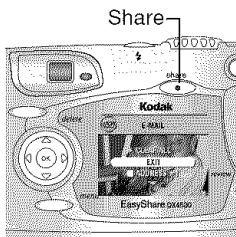

- 1 Press the Review button, then locate a picture or video.
- 2 Press the Share button. Press ▲/▼ to highlight Email , then press the OK button.
- 3 Press ▲/▼ to highlight an email address, then press the OK button. To send the picture to more than one person, repeat step 3 for each address.

Selected addresses are noted with a check mark; the email icon  appears on the status bar.

- 4 To remove a selection, highlight a checked address and press the OK button. To remove all email selections, highlight Clear All.
- 5 Press ▲/▼ to highlight Exit, then press the OK button.
Your selections are saved.
- 6 Press the Share button to exit the Share menu.

Emailing Tagged Pictures and Videos

When you transfer the tagged pictures and videos to your computer, the Kodak EasyShare software email screen opens and lets you immediately send the pictures and videos to the addresses you specified.

For details on address books and emailing, click the Help button in the Kodak EasyShare software.

Tagging Pictures and Videos as Favorites

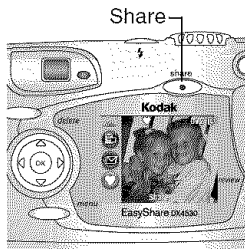

- 1 Press the Review button, then locate a picture or video.
- 2 Press the Share button. Press $\blacktriangle/\blacktriangledown$ to highlight Favorite \heartsuit , then press the OK button.

The Favorite icon \heartsuit appears on the status bar.

- 3 To remove the tag, press the OK button again.
- 4 Press the Share button to exit the Share menu.

Using Favorites On Your Computer

When you transfer tagged pictures and videos to your computer, you can retrieve, organize, and label them by subject, date, event, or any category you choose.

For details, click the Help button in the Kodak EasyShare software.









6 Customizing Your Camera Settings

Use Setup to customize camera settings according to your preferences.

Accessing Setup Mode/Menu



- 1 In any mode, press the Menu button.
- 2 Press / to highlight Setup , then press the OK button.

Setup Menu

	Default Print Quantity (page 50)		Video Out (page 52)
	Quickview (page 50)		Language (page 52)
	Liveview (page 51)		Format (page 53)
	Shutter Sound (page 51)		About (page 54)
	Date & Time Set (page 8)		

Changing the Print Quantity Default

The Default Print Quantity setting determines the value that is displayed on the Share Print screen (page 46). The default value is 1.

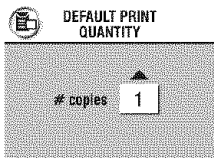

- 1 Press the Menu button.
- 2 Press $\blacktriangle/\blacktriangledown$ to highlight Setup , then press the OK button.
- 3 Highlight Default Print Quantity , then press the OK button.
- 4 Press $\blacktriangle/\blacktriangledown$ to indicate the new default quantity, then press the OK button.
- 5 Press the Menu button to exit the menu.



- This setting remains until you change it.*

Turning Off Quickview

After you take a picture or video, Quickview displays it on the camera screen for approximately 5 seconds (see page 21 and page 34). To save battery power, turn off Quickview.

- 1 Press the Menu button.
- 2 Press $\blacktriangle/\blacktriangledown$ to highlight Setup , then press the OK button.
- 3 Press $\blacktriangle/\blacktriangledown$ to highlight Quickview , then press the OK button.
- 4 Press $\blacktriangle/\blacktriangledown$ to highlight Off, then press the OK button.
- 5 Press the Menu button to exit the menu.

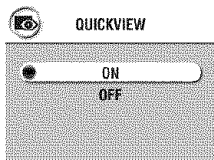

The picture is not displayed on the camera screen after you take it. To see the picture or video, press the Review button. This setting remains until you change it.

Turning On Liveview In Still Modes

The Liveview feature lets you use the camera screen as a viewfinder (see page 20). Press the OK button to turn the camera screen on and off.

NOTE: Liveview quickly depletes battery power; use it sparingly. The Liveview default setting is On in Close-up and Video modes.

- 1 Press the Menu button.
- 2 Press $\blacktriangle/\blacktriangledown$ to highlight Setup \equiv , then press the OK button.
- 3 Press $\blacktriangle/\blacktriangledown$ to highlight Liveview , then press the OK button.

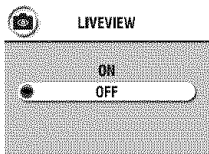

- 4 Press $\blacktriangle/\blacktriangledown$ to highlight On, then press the OK button.

The live image is displayed whenever the camera is on. Press the OK button to manually turn it off and on.

- 5 Press the Menu button to exit the menu.
This setting remains until you change it.

Turning Off the Shutter Sound

- 1 Press the Menu button.
- 2 Press $\blacktriangle/\blacktriangledown$ to highlight Setup \equiv , then press the OK button.
- 3 Press $\blacktriangle/\blacktriangledown$ to highlight Shutter Sound , then press the OK button.

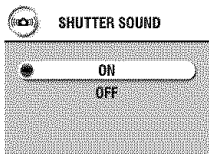



- 4 Press $\blacktriangle/\blacktriangledown$ to highlight Off, then press the OK button.

No sounds plays when a picture is taken.

- 5 Press the Menu button to exit the menu.
This setting remains until you change it.

Setting Video Out

Video Out matches the camera's video signal to the standard for your location. Video Out must be set correctly to run a slide show on a television or other external device (see page 41).

- 1 Press the Menu button.
- 2 Press $\blacktriangle/\blacktriangledown$ to highlight Setup , then press the OK button.
- 3 Press $\blacktriangle/\blacktriangledown$ to highlight Video Out , then press the OK button.

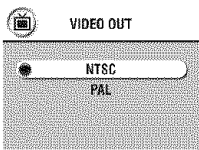

- 4 Press $\blacktriangle/\blacktriangledown$ to highlight an option:
NTSC—used in most countries except those in Europe and China. The United States and Japan use NTSC.

PAL—used in Europe and China.

- 5 Press the OK button to accept the change.
- 6 Press the Menu button to exit the menu.

This setting remains until you change it.

Selecting a Language

You can display menus and screen messages in different languages.

- 1 Press the Menu button.
- 2 Press $\blacktriangle/\blacktriangledown$ to highlight Setup , then press the OK button.
- 3 Press $\blacktriangle/\blacktriangledown$ to highlight Language , then press the OK button.

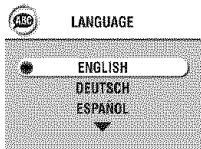

- 4 Press $\blacktriangle/\blacktriangledown$ to highlight an option, then press the OK button.

- 5 Press the Menu button to exit the menu.



*Text is displayed in the selected language.
 This setting remains until you change it.*

Formatting Internal Memory or SD/MMC Card



CAUTION:

Formatting erases all pictures and videos, including those that are protected. Removing a card during formatting may damage the card.

- 1 Press the Menu button.
- 2 Press / to highlight Setup , then press the OK button.
- 3 Press / to highlight Format , then press the OK button.

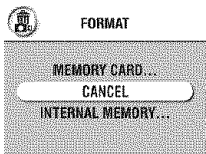



- 4 Press / to highlight an option:
 - MEMORY CARD**—deletes everything on the card; formats the card.
 - CANCEL**—exits without making a change.
 - INTERNAL MEMORY**—deletes everything in 32 MB internal memory.

- 5 Press the OK button.
- 6 Press / to highlight Continue Format, then press the OK button.

When the formatting is complete, the Setup menu appears.

Viewing Camera Information

- 1 Press the Menu button.
- 2 Press ▲/▼ to highlight Setup , then press the OK button.
- 3 Press ▲/▼ to highlight About , then press the OK button.
The camera model and the current firmware version appear.
- 4 Press the Menu button to exit the menu.

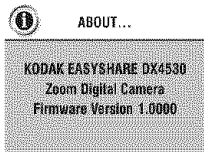

7 Installing the Software

NOTE: This product was designed and manufactured to existing industry standards as of this product's release date. Future hardware and operating systems may or may not support this Kodak product. If you experience compatibility issues between this product and future hardware products or operating systems, contact your hardware or operating system manufacturer or retailer.

Windows System Requirements

- Personal computer running Windows 98, 98SE, ME, 2000, or XP OS
- 233 MHz processor or greater (300 MHz recommended for Windows 2000 and XP)
- 64 MB of available RAM (128 MB recommended)
- 100 MB of available hard disk space
- CD-ROM drive
- Built-in USB port
- Color monitor with a minimum resolution of 800 x 600 pixels; High Color (16-bit) or True Color (24-bit) recommended
- Internet access for online printing and emailing

Mac OS X System Requirements

- Macintosh computer with a G3 or G4 processor
- Mac OS 10.1.2, minimum
- 128 MB of available RAM
- 200 MB of available hard disk space
- CD-ROM drive
- Built-in USB port
- Color monitor with a minimum resolution of 800 x 600 pixels; thousands or millions of colors recommended
- Internet access for online printing and emailing

Mac OS 8.6 and 9.x System Requirements

- PowerPC-based Macintosh computer
- Mac OS 8.6/9.x
- 64 MB of available RAM
- 200 MB of available hard disk space
- CD-ROM drive
- Built-in USB port
- Color monitor with a minimum resolution of 800 x 600 pixels; thousands or millions of colors recommended
- Internet access for online printing and emailing

NOTE: Mac OS 8.6 and 9.x do not support the Share button functions. Mac OS X is recommended for full functionality.

Install the Software

For information on the software applications included on the Kodak EasyShare software CD, click the Help button in the Kodak EasyShare software.

NOTE: If your computer is running Windows 2000, Windows XP Pro, or Mac OS X operating system, you need administrator privileges to install software. See your computer user's guide.



CAUTION:

Install Kodak EasyShare software *BEFORE* connecting the camera or optional camera dock to the computer. Failure to do so may cause the software to load incorrectly.

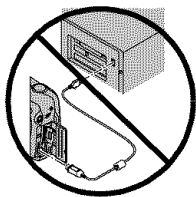

- 1 Before you begin, close all software applications that are open on your computer (including anti-virus software).
- 2 Place the Kodak EasyShare software CD into the CD-ROM drive.
- 3 Load the software:

Windows OS-based computer—if the install window does not appear, choose Run from the Start menu and type **d:\setup.exe** where **d** is the drive letter that contains the CD.

Mac OS 8.6 or 9.x—on the install window, click Continue.

Mac OS X—double-click the CD icon on the desktop, then click the Install icon.

- 4 Follow the on-screen instructions to install the software.
 - **Windows OS-based computers**—select Complete to automatically install the most commonly used applications. Select Custom to choose the applications you wish to install.
 - **Mac OS 8.6 or 9.x**—select Easy to automatically install the most commonly used applications.
 - **Mac OS X**—follow the on-screen instructions.

NOTE: When prompted, take a few minutes to electronically register your camera and software. This lets you receive information regarding software updates and registers some of the products included with the camera. You must be connected to your Internet service provider to register electronically.

To register later, see www.kodak.com/go/register.

- 5 If prompted, restart the computer. If you turned off anti-virus software, turn it back on. See the anti-virus software manual for details.

8 Connecting to the Computer



CAUTION:

Install Kodak EasyShare software before connecting the camera or optional dock to the computer. Failure to do so may cause the software to load incorrectly.

Connecting to the Computer

You can transfer pictures and videos from the camera to the computer using either the provided USB cable or the optional Kodak EasyShare camera dock or camera dock II. See page 61 for connecting with a camera dock.

Transferring Pictures With the USB Cable

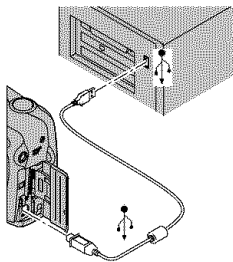

- 1 Turn off the camera.
- 2 Plug the labeled USB end of the USB cable into the labeled USB port on your computer. See your computer User's Guide for details.
- 3 Plug the other end of the USB cable into the labeled USB port on the camera.

An optional 3-volt AC adapter is available to save battery power (see page 95).

- 4 Turn on the camera.

Kodak EasyShare software prompts you through the transfer process.

NOTE: You can also use a Kodak multi-card reader or Kodak SD multimedia card reader-writer to transfer your pictures. Purchase accessories at a dealer of Kodak products. See www.kodak.com/go/dx4530accessories.

Printing Pictures From Your Computer

For details on printing pictures from your computer, click the Help button in the Kodak EasyShare software.

Printing From an Optional SD/MMC Card

- Automatically print tagged pictures when you insert your card into a printer with an SD/MMC slot. See your printer User's Guide for details.
- Make prints at an SD/MMC-capable Kodak picture maker. (We suggest contacting a location prior to visiting.)
- Take the card to your local photo retailer for professional printing.

Ordering Prints Online

Kodak EasyShare print service (provided by Ofoto www.ofoto.com) is just one of the many great online print services offered in the Kodak EasyShare software. You can easily:

- Upload your pictures.
- Edit, enhance, and add borders.
- Store pictures, and share them with family and friends.
- Order high-quality prints, photo greeting cards, frames, and albums—and have them delivered to your door.

9 Using the Optional Camera Dock II

The Kodak EasyShare camera dock II makes it easy to transfer your pictures and videos to the computer.

The camera dock is also a rapid battery charger for the included Kodak EasyShare Ni-MH rechargeable battery, and supplies power to the camera. (Only the battery can be recharged in the camera dock.) To keep the battery charged, store your camera in the camera dock.

Purchase accessories at a dealer of Kodak products. See www.kodak.com/go/dx4530accessories.



CAUTION:

Install the software from the Kodak EasyShare software CD before connecting the camera or dock to the computer. Failure to do so may cause the software to load incorrectly.

Camera Dock Package Contents

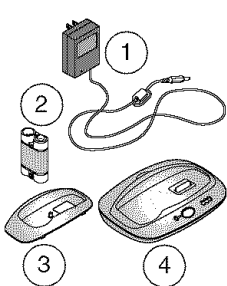

- 1 AC power adapter, 7V
Some AC adapters may be different from the one pictured.
- 2 Kodak EasyShare Ni-MH rechargeable battery
- 3 Universal insert
- 4 Camera dock
- 5 Quick Start Guide (not shown)

Installing the Camera Insert

Kodak EasyShare digital cameras are packaged with a custom camera insert, which is used to fit the camera to the camera dock.

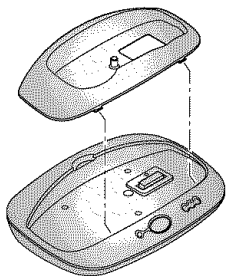

- 1 Place the front tabs on the custom insert into the slots in the camera dock cavity.
- 2 Fit the insert down into the cavity and snap the insert into place.

If You Do Not Have the Custom Insert

If you do not have the custom insert that was included with your camera, use the universal insert that is included with the camera dock II.

NOTE: The universal insert works with all Kodak EasyShare cameras. However, it may not match the perfect fit that the custom camera insert provides. Take extra care when placing the camera in the camera dock so that the dock connector and pins are not damaged.

Purchase accessories at a dealer of Kodak products. See www.kodak.com/go/dx4530accessories.

Connecting the Camera Dock

After the Kodak EasyShare software is loaded (see page 55), connect the camera dock to your computer and to an external power source. You need:

- The USB cable included with your camera
- The AC power adapter, 7V included with the camera dock



CAUTION:

Use only the 7V AC adapter included with the camera dock. Other adapters may cause damage to your camera, camera dock, or computer. Make sure the camera is not in the camera dock when connecting the dock to power and to the computer. Do not plug the 7V adapter into the camera.

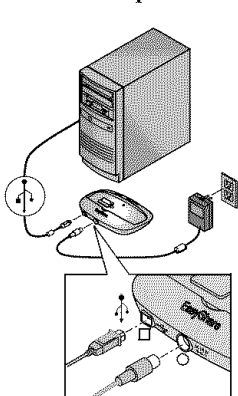

- 1 Plug the labeled  end of the USB cable into the labeled USB port on your computer. See your computer User's Guide for details.
- 2 Plug the other end of the USB cable into the square USB connector on the back of the camera dock.
- 3 Plug the 7V AC adapter into the round power connector on the back of the camera dock and into a power outlet.

Your AC adapter may be different from the one pictured or may have additional plugs. Use the plug that accommodates your type of power outlet.

Leave the camera dock connected to the computer for easy transferring of pictures and videos and for charging the battery.

Installing the Battery in the Camera

The camera dock will only charge the Ni-MH battery (not other batteries).

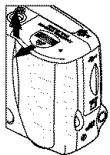

- 1 Turn off the camera.
- 2 Open the battery door.

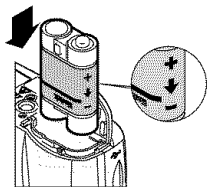

- 3 Install the battery as shown.



CAUTION:

The battery can only be inserted into the camera as shown. If the battery does not install, reposition it and try again. **DO NOT FORCE IT**; doing so can damage your camera.

- 4 Close the battery door.

IMPORTANT: *The battery is not charged when you receive it. See page 66 for charging instructions.*

Docking the Camera

To transfer pictures and videos from the camera to the computer, or to charge the battery:

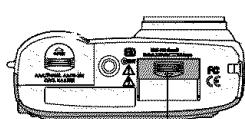

Dock connector
door

- 1 Turn **off** the camera.
- 2 On the camera bottom, slide the connector cover open.

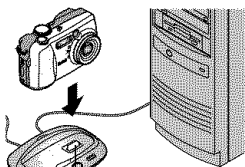

Connector
Power/
Transfer
light

- 3 Place the camera in the camera dock and push down to seat the connector.

The Power/Transfer light glows green when the camera is properly seated.

The camera is now powered by the camera dock instead of the camera batteries.

NOTE: If a Kodak EasyShare Ni-MH rechargeable battery is installed in the camera, the camera dock immediately begins charging.

Charging the Battery

The battery is not charged when you receive it.

- 1 Turn **off** the camera.
- 2 Make sure the battery is installed in the camera (see page 64).
- 3 Place the camera in the camera dock (see page 65).
 - Charging begins immediately.
 - The three green charging lights monitor the charging status:

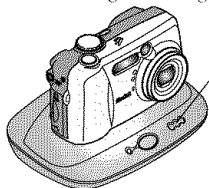

Charging Lights on Dock II

- battery low
- battery partially charged
- battery fully charged

- Full charging takes about 2.5 hours. After the battery is fully charged, leave the camera in the camera dock to maintain the full charge.
- Charging stops if you turn on the camera. If the camera is left in the camera dock with the power on, charging resumes when the camera enters Auto Power-off (see page 95).

NOTE: The camera dock only charges the provided Kodak EasyShare Ni-MH rechargeable battery. If you place the camera in the camera dock with any other type of batteries, rechargeable or not, no charging takes place. For further Troubleshooting information, see page 69.

Transferring Pictures and Videos

To transfer pictures and videos from your camera to your computer:

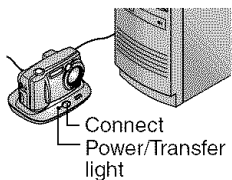

- 1 Place the camera in the camera dock. The camera can be on or off.

If the battery is being charged, charging pauses, then resumes after pictures and videos are transferred.

- 2 Press the Connect button.

The Power/Transfer light blinks green while the pictures are transferring.

- 3 For details on printing and emailing, see the Quick Start Guide or the Kodak EasyShare software Help.

NOTE: After transferring pictures and videos, leave the camera in the camera dock. Eight minutes after the transfer is complete, the camera dock resumes charging as necessary.

Caution When Using a Tripod

Do not connect a tripod to the camera dock. Remove the camera from the camera dock and connect the tripod directly to the camera.

Earlier Camera Dock Model

If you have the Kodak EasyShare camera dock, not the camera dock II, the functionality is exactly the same as described in this chapter. The only difference is that the earlier camera dock has one indicator light.

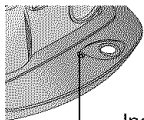

Indicator
light

Indicator light status:

Steady green—camera is properly seated in the camera dock.

Blinking green—pictures and videos are transferring.

Steady red—battery is charging.

Blinking red—error condition.

IMPORTANT: *When using the earlier camera dock, several discharge/recharge cycles may be necessary so that the battery holds a full charge.*

10 Troubleshooting

When you have questions about your camera or camera dock II, start here. Additional technical information is available in the ReadMe file located on the Kodak EasyShare software CD. For updates to Troubleshooting information, see www.kodak.com/go/dx4530support.

Troubleshooting—Camera

Camera Problems

Problem	Cause	Solution
Camera does not turn on.	Battery is not properly installed.	Remove and reinstall the batteries (page 5).
	Battery is not charged.	Replace (page 5) or recharge the batteries (page 66).
	Lens cap is on, preventing lens from extending.	Remove the lens cap.
Pictures remaining number does not decrease after taking a picture.	The picture does not take up enough space to decrease the number.	The camera is operating normally. Continue taking pictures.

Problem	Cause	Solution
Rechargeable Ni-MH battery pack has a short life.	There is dirt on the battery contacts.	Wipe the battery contacts with a clean, dry cloth before loading batteries in the camera.
	The battery needs to be conditioned.	<ol style="list-style-type: none"> <li data-bbox="539 283 891 341">1 Place the camera on the camera dock. (See page 61.) <li data-bbox="539 341 919 569">2 For: EasyShare camera dock— When the charge light turns green, remove the camera from the dock. After a minimum of 5 minutes, place the camera back on the dock. EasyShare camera dock II— When all 3 lights turn green, remove the camera from the dock. After a minimum of 5 minutes, place the camera back on the dock <li data-bbox="539 771 919 865">3 Repeat steps 1 and 2 until the combined charge time equals a minimum of 2 hours.
Camera does not turn off; lens does not retract.	Alkaline batteries were installed in the camera.	Do not use alkaline batteries. Turn the Mode dial off, remove the alkaline batteries, and replace with an approved battery type (page 13). If the Mode dial is not off when you replace the batteries, the camera may not turn back on. In that case, turn the Mode dial off, then back on.

Problem	Cause	Solution
Shutter button does not work.	Camera is not turned on.	Turn on the camera (page 7).
	The camera is processing a picture; the ready light (near the viewfinder) is blinking.	Wait until the light stops blinking before attempting to take another picture.
	The card or internal memory is full.	Transfer pictures to your computer (page 59), delete pictures from the camera (page 38), switch storage locations (page 11), or insert a card with available memory (page 10).
Stored pictures are damaged.	The card was removed when the ready light was blinking.	Make sure the ready light is not blinking before removing the card.
Part of the picture is missing.	Something was blocking the lens when the picture was taken.	Keep hands, fingers, or other objects away from the lens when taking pictures.
	Your eye or the picture was not centered correctly in the viewfinder or camera screen.	Leave space around subject when centering picture in viewfinder or camera screen.

Problem	Cause	Solution
In Review mode, you do not see a picture (or the expected picture) on the camera screen.	The camera may not be accessing the correct storage location.	Check the picture storage location setting (page 11).
In Review mode, pictures are displayed as black screens.	Lens cap is on, preventing lens from extending.	Remove the lens cap.
Picture orientation is not accurate.	The camera sensed that it was rotated or tilted while the picture was taken.	Set the Orientation Sensor (page 31). Turn off the Orientation Sensor when your subject is above or below you (such as in the sky or on the floor).
Camera freezes up when a card is inserted or removed.	Camera detects an error when the card was inserted or removed.	Turn the Mode dial off, then back on. Make sure the camera is turned off before inserting or removing a card.

Problem	Cause	Solution
Picture is too dark.	Flash is not on or did not function.	Turn on the flash (page 24).
	The subject is too far away for the flash to have an effect.	Move so there is no more than 11.2 ft (3.4 m) between the camera and the subject; 6.6 ft (2.0 m) in Telephoto.
	The subject is in front of a bright light (backlit).	Use Fill flash (page 24) or change your position so the light is not behind the subject.
	Lighting condition is too dark.	Increase Exposure Compensation (page 27) or Long Time Exposure (page 28).
Picture is too light.	The flash is not needed.	Change to Auto flash (page 24).
	The subject was too close when the flash was used.	Move so there is at least 2.0 ft (0.6 m) between the camera and the subject.
	The light sensor is covered.	Hold the camera so your hands or other objects do not cover the light sensor.
	Lighting condition is too bright.	Decrease exposure compensation (page 27).

Problem	Cause	Solution
Picture is not clear.	The lens is dirty.	Clean the lens (page 92).
	Subject too close when taking picture.	Move so there is at least 2.0 ft (0.6 m) between the camera and the subject, or at least 2.8 in. (7.0 cm) in Close-up mode.
	Subject or the camera moved while the picture was taken.	Hold the camera steady while taking the picture.
	The subject is too far away for the flash to be effective.	Move so there is no more than 11.2 ft (3.4 m) between the camera and the subject; 6.6 ft (2.0 m) in Telephoto.
Slide show does not run on external video device.	Video Out setting is incorrect.	Adjust the camera Video Out setting (NTSC or PAL, page 52).
	External device is set incorrectly.	Refer to the external device's user's guide.

Camera/Computer Communications

Problem	Cause	Solution
The computer cannot communicate with the camera.	Camera power is off.	Turn on the camera (page 7).
	Battery is not charged.	Replace (page 5) or recharge the batteries (page 66).
	Some Advanced Power Management utilities on laptops can turn off ports to save battery life.	See the Power Management section of your laptop user's guide to disable this feature.
	USB cable is not securely connected.	Connect cable to camera and computer port (page 59).
	Software is not installed.	Install the software (page 55).
	The Battery Monitor or similar software runs constantly.	Close that software before starting the Kodak EasyShare software.
Cannot transfer pictures to computer. The Add New Hardware Wizard cannot locate drivers.	Software is not installed on computer.	Disconnect USB cable (if using camera dock, disconnect cable and remove camera from dock). Install Kodak EasyShare software (page 55).

SD/MMC Cards and Internal Memory

Problem	Cause	Solution
The camera does not recognize your SD/MMC card.	Card may not be SD/MMC certified.	Purchase a certified SD/MMC card (page 10).
	Card may be corrupt.	Reformat the card (page 53). Caution: Formatting erases all pictures and videos, including protected files.
	No card is inserted in camera or card is not fully inserted.	Insert a card into the card slot, then push to seat the connector (page 10).
Camera freezes up when a card is inserted or removed.	Camera detects an error when the card was inserted or removed.	Turn the Mode dial off, then back on. Make sure the camera is off when inserting or removing a card.
Memory card full.	Storage is full.	Transfer pictures and videos to the computer, then delete them from the camera.
	The maximum number of files or folders is reached (or other directory concern).	Transfer pictures and videos to the computer, then format the card or internal memory (page 53). Caution: Formatting a card erases all pictures and videos, including protected files. (Formatting internal memory also erases email addresses. To restore addresses, see Kodak EasyShare software Help.)

Camera Screen Messages

Message	Cause	Solution
No images to display	There are no pictures in the current storage location.	Change your picture storage location setting (page 11).
Memory card requires formatting	Card is corrupted or formatted for another digital camera.	Insert a new card (page 10) or format the card (page 53).
Memory card cannot be read (Please format card or insert another card)		
Internal memory requires formatting	Camera internal memory is corrupted.	Format the internal memory (page 53).
Internal memory cannot be read (Please format internal memory)		
No memory card (Files not copied)	No card in the camera. Your pictures were not copied.	Insert a card.
Not enough space to copy files (Files not copied)	There is not enough space in the location you are copying to (internal memory or the card).	Delete pictures from the location you are copying to (page 38), or insert a new card.
Read only card, change to internal memory to capture	Card in the camera is write-protected.	To take a picture, insert a new card or change storage location to internal memory (page 11).

Message	Cause	Solution
Card is protected (Reset switch on card)	Switch on SD card is in write-protect position.	Reset the switch as shown on camera screen.
Card is locked (Insert a new card)	Card is write-protected.	To take a picture, insert a new card or change storage location to internal memory (page 11).
Card is unusable (Insert a new card)	Card is slow, corrupted, or unreadable.	Insert a new card (page 10).
Recording stopped. Record in internal memory (Card speed is slow)	Card cannot be used in the camera.	Change storage location to internal memory (page 11).
Memory card is full (Cannot save Share tagging)	There is no space remaining.	Insert a new card (page 10), transfer pictures (page 59), or delete pictures (page 38).
Internal memory is full (Cannot save Share tagging)		Insert a card (page 10), transfer pictures (page 59), or delete pictures (page 38).
Date/Time entry screen appears automatically	This is the first time you turned on the camera; or the batteries have been removed for an extended period of time; or the batteries are exhausted.	Reset the clock (page 8).

Message	Cause	Solution
Unrecognized File Format	Camera cannot read the picture format.	Transfer the unreadable picture to the computer (page 59), or delete the picture (page 38).
High camera temperature. (Camera will be turned off.)	The internal temperature of the camera is too high for the camera to operate. The viewfinder light glows red and the camera turns off in five seconds.	Leave the camera off for several minutes, then turn it back on. If the message reappears, repeat the sequence above until the message does not appear.
Memory Card is full	There is no more space on the card in the camera.	Delete pictures from the card (page 38), insert a new card, or change storage location to internal memory (page 11).
Internal Memory is full	There is no more space in the camera's internal memory.	Delete pictures from the internal memory (page 38) or change storage location to Auto and insert card (page 10).
No Address Book in Camera	Address book has not been copied from the computer to the camera.	Create and copy address book from the computer. See Kodak EasyShare software Help.
Other error code	An error is detected.	Turn the Mode dial off, then back on. If the error appears again, call for service.

Camera Ready Light Status

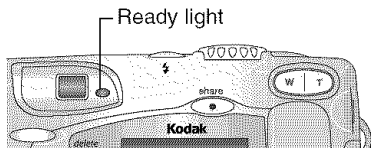

Problem	Cause	Solution
Ready light does not turn on and the camera does not work.	Camera is not turned on.	Turn on the camera (page 7).
	Batteries are exhausted.	Replace (page 5) or recharge the batteries (page 66).
	Mode dial was on when batteries were reloaded.	Turn Mode dial off, then back on.
Ready light glows steady green.	Camera is on; ready to take a picture or video.	The camera is operating normally.
Ready light blinks red.	Batteries are low or exhausted.	Replace (page 5) or recharge the batteries (page 66).
	Card is too slow for Video mode.	Change your storage location to internal memory (page 11), or use a different card.

Problem	Cause	Solution
Ready light glows steady red.	Camera's internal memory or card is full.	Transfer pictures to your computer (page 59), delete pictures from the camera (page 38), switch storage locations (page 11), or insert a card with available memory (page 10).
	Camera processing memory is full.	Wait. Resume picture taking when the light turns green.
	Your card is read-only.	Change your storage location to internal memory (page 11), or use a different card.
Ready light blinks green.	Camera is starting up or picture is being saved.	Camera is operating normally.
Ready light blinks yellow.	Flash is not charged.	Wait. Resume picture taking when the light stops blinking and turns green.
	Auto exposure or auto focus are not locked.	Release the Shutter button and recompose the picture.

Troubleshooting—Camera Dock II

Camera Dock II Problems

Problem	Cause	Solution
Pictures are not transferred to the computer	AC adapter or USB cable is not securely connected.	Check the connections (page 63).
	Software is not installed.	Install the software (page 55).
	Computer needs to be restarted.	Restart the computer and try again.
	Camera was removed from the camera dock during picture transfer.	Replace the camera on the camera dock and press the Connect button.
	Connect button was not pressed.	Press the Connect button.

Camera Dock II Light Status

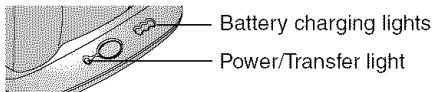

Camera Dock Power/Transfer Light		
Light Status	Cause	Comment
Light glows steady green	Camera is properly seated in the camera dock.	The camera and camera dock are operating normally.
Light blinks green	Pictures and videos are being transferred to the computer.	
Light is off	Camera is not properly seated in camera dock.	Remove the camera and re-seat it (page 65).

Camera Dock Charging Lights		
Light Status	Cause	Comment
○○○ No lights	Charging has not started.	The camera is not seated in the camera dock (page 65). Camera is turned on. Turn off to begin charging. Rechargeable battery is not installed in camera.
○●● One green light	Battery is low.	The camera is charging.
○●○ Two green lights	Battery is partially charged.	

Camera Dock Charging Lights

Light Status	Cause	Comment
 Three green lights	Battery is fully charged.	Charging resumes when necessary.

Camera Dock Error Light

Light Status	Cause	Comment
 One blinking red light	Battery is installed incorrectly.	Reinstall the battery (page 64).
	The battery or connector pins are damaged.	Check for damage.
	The camera and battery have been exposed to very high or low temperatures.	Slowly return the camera and battery to room temperature.

11 Getting Help

Helpful Web Links

Help with Windows operating system and working with digital pictures	www.kodak.com/go/pcbasics
Help with your Kodak EasyShare DX4530 zoom digital camera	www.kodak.com/go/dx4530support
Download the latest camera software and firmware	www.kodak.com/go/dx4530downloads
Optimize your printer for truer, more vibrant colors	www.kodak.com/go/onetouch
Get support for cameras, software, accessories, more	www.kodak.com/go/camerasupport
Purchase camera accessories	www.kodak.com/go/dx4530accessories
Register your camera	www.kodak.com/go/register

Help in this Manual

See Troubleshooting, page 69 for help with problems you may have with your camera, camera/computer connections, camera dock, or SD/MMC cards.

Software Help

Refer to the Quick Start Guide or Kodak EasyShare software Help.

Telephone Customer Support

If you have questions concerning the operation of the software or camera, you may speak with a customer support representative.

Before You Call

Please have the camera or camera dock connected to your computer, be at your computer, and have the following information available:

Operating system _____

Processor speed (MHz) _____

Computer model _____

Amount of memory (MB) _____

Exact error message you received _____

Version of installation CD _____

Camera serial number _____

Telephone Numbers

Australia	1800 147 701
Austria/Osterreich	0179 567 357
Belgium/Belgique	02 713 14 45
Brazil	0800 150000
Canada	1 800 465 6325
China	800 820 6027
Denmark/Danmark	3 848 71 30
Ireland/Eire	01 407 3054
Finland/Suomi	0800 1 17056
France	01 55 1740 77
Germany/Deutschland	069 5007 0035
Greece	00800 441 25605
Hong Kong	800 901 514
India	91 22 617 5823
Italy/Italia	02 696 33452
Korea	00798 631 0024
Netherlands/Nederland	020 346 9372
New Zealand	0800 440 786
Norway/Norge	23 16 21 33
Philippines	1 800 1 888 9600
Portugal	021 415 4125
Singapore	800 6363 036
Spain/Espana	91 749 76 53

Sweden/Sverige	08 587 704 21
Switzerland/Schweiz/Suisse	01 838 53 51
Taiwan	0 080 861 008
Thailand	001 800 631 0017
UK	0870 243 0270
United States	1 800 235 6325
Outside the United States	585 726 7260
International Toll Line	+44 131 458 6714
International Toll Fax	+44 131 458 6962

For the most up-to-date listings, see
www.kodak.com/US/en/digital/contacts/DAIInternationalContacts.shtml

12 Appendix

Camera Specifications

Kodak EasyShare DX4530 zoom digital camera		
Camera screen		Transmissive reflective LCD with anti-glare coating; 1.8 in. (45.7 mm); color; 72,000 pixels Preview rate: 20.4 fps
Color		24-bit, millions of colors
Communication with computer	USB	Via USB cable or camera dock
Dimensions	Width	4.3 in. (110.5 mm)
	Depth	1.5 in. (39.0 mm)
	Height	2.6 in. (66.0 mm)
	Weight	7.4 oz (210 g) with battery and card
Exposure control		Multi-pattern TTL-AE with program modes (Standard, Sport, Night, Long Time Exposure, Exposure Compensation)
File format	Still	JPEG/EXIF v2.2 
	Video	Quicktime movie
Flash	Modes	Auto, Fill, Red-eye, Off
	Range (at ISO 140)	Wide: 2.0 to 11.2 ft (0.6 to 3.4 m) Tele: 2.0 to 6.6 ft (0.6 to 2.0 m)
	Charging Time	< 7 seconds with charged battery

Kodak EasyShare DX4530 zoom digital camera

Focus Distance	Close-up	Wide angle: 2.8 to 28 in. (7 to 70 cm); Telephoto: 11 to 28 in. (28 to 70 cm)
	Standard	2 ft (0.6 m) to infinity
	Landscape	Fixed focus
ISO		Automatic (130-200)
Lens	Type	Optical quality glass, 6 groups/7 elements (2 aspherical lenses)
	Maximum Aperture	f/2.8 - f/4.8
	Focal Length	38 - 114 mm
Operating Temperature		32 to 104 ^o F (0 to 40 ^o C)
Picture storage		32 MB internal; SD or MMC card
Pixel resolution	★★★ ★★★ ★★ ★	Best: 2580 x 1932 (5.0 M) pixels Best (3:2): 2580 x 1720 (4.5 M) pixels Better: 2032 x 1524 (3 M) pixels Good: 1288 x 966 (1.2 M) pixels
Power	Battery	(1) CRV3 (included) (2) AA lithium (optional) (2) AA Ni-MH rechargeable (optional)
	AC adapter	3V DC (optional)
Self Timer		10 seconds
Tripod socket		Yes
Video resolution		320 x 240 pixels, 15 fps
Video Out		NTSC or PAL selectable
Viewfinder		Real image optical

Kodak EasyShare DX4530 zoom digital camera

White balance	Automatic
Zoom (still capture)	3X optical, 3.3X digital

Original Factory Settings—Camera

Feature	Factory Setting
Date/Time	2003/1/1; 12:00
Date/Time Stamp	Off
Exposure Compensation	0.0
Flash	Auto, Sport, Night: Auto Landscape, Close-up, Video: Off
Image Storage	Auto
Liveview	Off
Orientation Sensor	On
Shutter Sounds	On
Storage Location	Auto
Print Quantity	1
Picture Quality	Best
Quickview	On
Self Timer	Off
Slide Show Interval	5 seconds
Video Out	NTSC

Upgrading Your Software and Firmware

Download the latest versions of the software included on the Kodak EasyShare software CD and the camera firmware (the software that runs on the camera). See www.kodak.com/go/dx4530downloads.

Tips, Safety, Maintenance

- Always follow basic safety precautions. Refer to the “Important Safety Instructions” booklet packed with your camera.
- Do not allow any chemicals, such as suntan lotion, to come into contact with the painted surface of the camera.
- If the camera has been subjected to inclement weather or you suspect water has gotten inside the camera, turn off the camera and remove the battery and card. Allow all components to air-dry for at least 24 hours before using the camera again.
- Clean the lens and camera screen:
 - 1 Blow gently on the lens or camera screen to remove dust and dirt.
 - 2 Moisten the lens or camera screen by breathing lightly on it.
 - 3 Wipe the lens or camera screen gently with a soft, lint-free cloth or an untreated lens-cleaning tissue.
- Do not use cleaning solutions unless they are designed specifically for camera lenses. **Do not wipe the camera lens or camera screen with chemically treated eyeglass lens tissue. It may scratch the lens.**
- Wipe the outside of the camera with a clean, dry cloth. Never use harsh or abrasive cleaners or organic solvents on the camera or any of its parts.
- Service agreements are available in some countries. Contact a dealer of Kodak products for more information.
- For digital camera disposal or recycling information, please contact your local authorities. In the US, see the Electronics Industry Alliance Web site at www.eiae.org or the Kodak Web site at www.kodak.com/go/dx4530support.

Storage Capacities

File sizes can vary. You may be able to store more or fewer pictures and videos. Purchase accessories at a dealer of Kodak products. See www.kodak.com/go/dx4530accessories.

Picture Storage Capacity

	Number of pictures			
	Best ★★★	Best (3:2) ★★★★	Better ★★	Good ★
16 MB SD/MMC	10	11	16	38
32 MB internal memory	21	24	34	79
32 MB SD/MMC	20	23	32	77
64 MB SD/MMC	41	46	65	154
128 MB SD/MMC	83	93	131	309
256 MB SD/MMC	166	186	263	618

Video Storage Capacity

Video storage capacity may vary by brand of card.

	Approximate minutes of video
16 MB SD/MMC	1
32 MB internal memory	2
32 MB SD/MMC	2
64 MB SD/MMC	4
128 MB SD/MMC	8
256 MB SD/MMC	16

Locating Pictures and Videos on a Card

Pictures stored on SD/MMC Cards use a standard agreed upon by many camera manufacturers. This lets you use the cards in different cameras. If you use a card reader to retrieve your files, the following file structure may be helpful.

MISC folder—contains the order files created when you use the Share feature to tag files for printing, emailing, and as favorites.

SYSTEM folder—used for updating camera firmware.

DCIM folder—root level folder, contains the 100K4530 folder. When you turn on the camera or insert a different card, empty folders in the DCIM folder are removed.

100K4530 subfolder—contains all the pictures on the card.

Card File Naming Conventions

- Pictures are named 100_####.JPG, and are numbered in the order in which they are taken. The first picture is named 100_0001.JPG; the highest number allowed is 100_9999.JPG.
- When a card contains a picture named 100_9999.JPG in the \DCIM\100K4530 folder, subsequent pictures appear in a new folder (\DCIM\101K4530), beginning with picture 101_0001.JPG.
- Even if you transfer pictures to the computer or delete pictures from the camera, the camera continues to use consecutive numbers for all subsequent pictures. For example, if the last picture taken was 100_0007.JPG and you delete it, the next picture you take is named 100_0008.JPG.
- When you insert a different card into your camera, the next picture number is defined by incrementing the higher of the last picture taken by the camera, or the highest existing picture number in the folder.
- If you use the card in a camera other than the Kodak EasyShare DX4530 zoom digital camera, and that camera manufacturer adheres to this file structure standard, the \DCIM folder contains a folder named by that camera.

Power-Saving Features

If No Activity For	The	To Turn It Back On
1 minute	Camera screen turns off	Press the OK button.
8 minutes	Camera enters power-save mode	Press any button.
3 hours	Camera turns off	Turn camera off, then on.

Optional AC Adapter

To save battery power when reviewing, copying, and transferring pictures, use a Kodak 3-volt AC adapter. Purchase accessories at a dealer of Kodak products. See www.kodak.com/go/dx4530accessories.

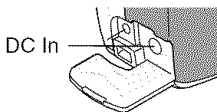

Connect the 3-volt adapter to the camera's DC-in port and to a power outlet.

NOTE: The 3-volt adapter is NOT compatible with a Kodak EasyShare camera dock.

Regulatory Information

FCC Compliance and Advisory

Kodak EasyShare DX4530 zoom digital camera Tested to comply with FCC Standards. FOR HOME OR OFFICE USE
--

This equipment has been tested and found to comply with the limits for a Class B digital device, pursuant to Part 15 of the FCC Rules. These limits are designed to provide reasonable protection against harmful interference in a residential installation.

This equipment generates, uses, and can radiate radio frequency energy and, if not installed or used in accordance with the instructions, may cause harmful interference to radio communications. However, there is no guarantee that interference will not occur in a particular installation.

If this equipment does cause harmful interference to radio or television reception, which can be determined by turning the equipment off and on, the user is encouraged to try to correct the interference by one or more of the following measures: 1) reorient or relocate the receiving antenna; 2) increase the separation between the equipment and the receiver; 3) connect the equipment to an outlet on a circuit different from that to which the receiver is connected; 4) consult the dealer or an experienced radio/TV technician for additional suggestions.

Any changes or modifications not expressly approved by the party responsible for compliance could void the user's authority to operate the equipment. Where shielded interface cables have been provided with the product or specified additional components or accessories elsewhere defined to be used with the installation of the product, they must be used in order to ensure compliance with FCC regulation.

Canadian DOC Statement

DOC Class B Compliance—This Class B digital apparatus complies with Canadian ICES-003.

Observation des normes-Class B—Cet appareil numérique de la classe B est conforme à la norme NMB-003 du Canada.

Index

A

- AA batteries, installing, 5
- about
 - camera information, 54
 - picture, video, 44
- AC adapter, 95
- accessories
 - battery, 14
- accessories, buying, 85
- adjusting
 - exposure compensation, 27
 - picture quality, 29
- alkaline batteries, 5
- arrow buttons, ii
- audio speaker, iv
- auto
 - flash, 24
 - focus framing marks, 22
 - mode, 15
 - power-down, 95

B

- batteries
 - alkaline, 5
 - charging rechargeable
 - battery, 66

- expected life, 13
- extending life, 14
- loading AA lithium, 5
- loading CRV3, 5
- loading rechargeable
 - battery, 64
- power level, 9
- safety and handling, 14
- types, 13

buttons

- arrow, ii
- delete, 21
- flash, 24
- menu, 11
- OK, 7
- review, 37
- share, 45
- shutter, 15
- zoom, 23

C

- cable
 - audio/video, 3, 42
 - power, camera, 95
 - power, camera dock, 61
 - USB, 3, 59

- camera dock, 82
 - charging lights, 66
 - charging rechargeable battery, 66
 - connector door, iv
 - docking camera, 65
 - earlier model, 68
 - installing insert, 62
 - lights status, 83
 - package contents, 61
 - power connection, 63
 - transferring pictures, 67
 - USB connection, 63
 - using, 61
 - camera screen
 - displaying languages, 52
 - picture location icon, 9
 - reviewing last picture, 21
 - reviewing last video, 34
 - reviewing pictures, 37
 - reviewing videos, 37
 - status bar, 9
 - turning off quickview, 50
 - turning on liveview, 51
 - using as viewfinder, 20
 - Canadian compliance, 96
 - card, memory, 94
 - caring for your camera, 92
 - changing picture or video location, 11
 - charging lights, camera dock, 66
 - charging rechargeable battery, 66
 - checking location setting, 12
 - cleaning camera, lens, 92
 - clock, setting, 8
 - close-up mode, 19
 - computer
 - connecting camera, 59
 - connecting camera dock, 63
 - system requirements, 55
 - connecting camera dock, 63
 - connecting to computer, 59
 - copy pictures
 - card to memory, 43
 - to computer, 59
 - copy pictures and videos to computer, 67
 - CRV3 battery
 - expected life, 13
 - installing, 5
 - customer support numbers, 86
 - customizing camera settings, 49
- D**
- date
 - imprinting on pictures, 30
 - setting, 8

- DCIM folder, card, 94
- defaults
 - changing print quantity, 50
 - original settings, 91
- deleting
 - by formatting, 53
 - during quickview, 34
 - from internal memory, 38
 - from SD/MMC Card, 38
 - last picture, 21
 - last video, 34
 - protecting pictures, videos, 40
- digital zoom, 23
- display problems, 71
- displaying slide show, 41
- disposal, recycling, 92
- docking camera, 62, 65
- downloading pictures, 59, 67
- E**
- early camera dock, 68
- EasyShare software,
 - installing, 55
- emailing pictures, videos, 47
- exposure
 - compensation, 27
 - long time, 28
- external video device
 - setting video out, 52
 - viewing pictures, videos, 42
- F**
- favorites, tagging for, 48
- FCC compliance, 95
- file names, card, 94
- firmware
 - upgrading, 92
 - version, 54
- flash, using, 24
- focus framing marks, 22
- folders, card, 94
- formatting SD/MMC card, 53
- G**
- guidelines, battery, 14
- H**
- help
 - camera, 69
 - camera dock, 82
 - software, 85
 - telephone support, 86
 - web links, 85
- I**
- icons
 - camera status, 9

- mode dial, 6
- image storage menu, 11
- information
 - about camera, 54
 - about pictures, videos, 44
- insert, for camera dock, 62
- installing
 - AA lithium batteries, 5
 - CRV3 battery, 5
 - insert, camera dock, 62
 - rechargeable battery, 64
 - SD/MMC card, 10
 - software, 57
- internal memory
 - formatting, 53
 - setting picture, video
 - location, 11
 - storage capacity, 93
- K**
- Kodak EasyShare software
 - getting help, 85
 - installing, 57
 - upgrading, 92
- Kodak web sites, 85
- L**
- landscape mode, 18
- language, setting, 52
- lens
 - accessory, 4
 - cap, 4
 - cleaning, 92
- light
 - camera dock, 83
 - camera dock II, 83
 - charging, 66, 68
 - error, camera dock II, 84
 - self-timer, camera, 26, 36
- lithium batteries, expected
 - life, 13
- liveview
 - turning on, 51
 - using camera screen as
 - viewfinder, 20
- loading
 - AA lithium batteries, 5
 - CRV3 battery, 5
 - rechargeable battery, 64
 - SD/MMC card, 10
 - software, 57
- long time exposure, 28
- M**
- Mac
 - system requirements, 56
- Macintosh
 - installing software on, 57

- system requirements, 56
- magnify picture, 39
- maintenance, camera, 92
- memory
 - storage location setting, 11
- memory card
 - inserting, 10
 - storage capacities, 93
- menu button, 11
- menus
 - image storage, setting, 11
 - overview, 6
- MISC folder, card, 94
- mode dial, 6
- modes
 - auto, 15
 - close-up, 19
 - landscape, 18
 - night, 17
 - off, 6
 - sport, 16
 - video, 33
- monitor, requirements, 55

N

- night mode, 17
- Ni-MH rechargeable battery
 - expected life, 13
- NTSC, video out setting, 52

O

- OK button, 7
- online help, 85
- online prints, ordering, 60
- optical zoom, 23, 34
- orientation sensor, 31
- overview, camera, ii
- overview, camera menus, 6

P

- package contents
 - camera, 3
 - camera dock, 61
- PAL, video out setting, 52
- parallax marks, 20
- pictures
 - checking location, 12
 - copying, 43
 - date imprint, 30
 - deleting, 38
 - emailing tagged, 47
 - file naming, 94
 - locating on card, 94
 - magnifying, 39
 - printing, 60
 - printing tagged, 46
 - protecting, 40
 - quality, setting, 29
 - reviewing, 37

- storage capacity, 93
 - taking, 15
 - transferring to
 - computer, 59, 67
 - power
 - camera dock, 63
 - optional AC adapter, 95
 - turning camera on, 7
 - power-down, auto, 95
 - printing
 - changing default quantity, 50
 - from a card, 60
 - optimizing printer, 85
 - pictures, 60
 - this user guide, 1
 - product overview, ii
 - protecting pictures, videos, 40
- Q**
- quality
 - print, digital zoom, 23
 - setting, 29
 - quickview
 - turning off, 50
 - using, 21, 34
- R**
- ReadMe file, 69
 - ready light
 - camera, 15
 - recycling, disposal, 92
 - red-eye, flash, 24
 - regulatory information, 95, 96
 - removable memory card, 10
 - requirements
 - Mac, 56
 - Windows OS-based, 55
 - resolution, setting, 29
 - review button, 37
 - review mode, 37
 - reviewing pictures
 - as you take them, 21
 - camera screen, 37
 - deleting, 38
 - magnify, 39
 - protecting, 40
 - slide show, 41
 - reviewing videos
 - as you take them, 34
 - camera screen, 37
 - deleting, 38
 - protecting, 40
 - slide show, 41
 - running slide show, 41
- S**
- safety, 92
 - SD/MMC card

- file name conventions, 94
- formatting, 53
- inserting, 10
- printing from, 60
- setting picture or video
 - location, 11
 - storage capacities, 93
- secure digital card, inserting, 10
- self-timer
 - pictures, 26
 - videos, 35
- sensor, orientation, 31
- service and support
 - telephone numbers, 86
 - Web site, 85
- setting
 - date and time, 8
 - flash, 24
 - language, 52
 - mode dial menus, 6
 - picture quality, 29
 - picture, video storage
 - location, 11
 - resolution, 29
 - self-timer, 26, 35
 - video out, 52
- setup mode, using, 49
- share button, 45
- shutoff, auto, 95
- shutter
 - problems, 71
 - self-timer delay, 26, 35
 - sounds, 51
 - taking pictures, 15
- sleep mode, 95
- slide show
 - continuous loop, 42
 - problems, 74
 - running, 41
- software
 - getting help, 85
 - installing, 57
 - upgrading, 92
- sounds, shutter, 51
- speaker, iv
- specifications
 - camera, 89
 - Mac, 56
 - Windows OS-based, 55
- sport mode, 16
- status
 - bar, 9
 - camera, 9
 - picture storage location, 12
- storage capacity, memory, 93
- strap
 - lens cap, 4
 - wrist, 4

support, technical, 85, 86
system folder, card, 94
system requirements
 Mac, 56
 Windows, 55

T

tagging
 for email, 47
 for favorites, 48
 for print, 46
 when to tag, 45
taking pictures, 15
taking videos, 33
telephone support, 86
television, slide show, 41
time, setting, 8
timer, shutter delay, 26, 35
tips
 battery guidelines, 14
 maintenance, 92
 ReadMe file, 69
 safety, 92
transferring to computer, 59, 67
trash can, deleting, 21, 34
tripod, caution, 67
troubleshooting
 camera dock, 82
turning camera on and off, 7

U

universal dock insert, 62
upgrading software,
 firmware, 92
URLs, Kodak web sites, 85

V

video mode, using, 33
video out, setting, 52
videos
 checking location, 12
 copying, 43
 date display, 44
 deleting, 38
 emailing tagged, 47
 file naming, 94
 protecting, 40
 reviewing, 37
 storage capacities, 93
 taking, 33
 transferring to
 computer, 59, 67
 viewing, 37
viewfinder, using camera
 screen, 20
viewing
 camera information, 54
 picture, video
 information, 44

viewing picture

after taking, 21, 37

magnified, 39

viewing video, after taking, 34

W

Windows

installing software, 57

system requirements, 55

wrist strap, 4

Z

zoom, digital, optical, 23