

BICYCLE OWNER'S MANUAL

HELMETS

SAVE

LIVES !!!

**ALWAYS WEAR A PROPERLY
FITTED HELMET WHEN
YOU RIDE YOUR BICYCLE.
DO NOT RIDE AT NIGHT.
AVOID RIDING IN WET
CONDITIONS.**

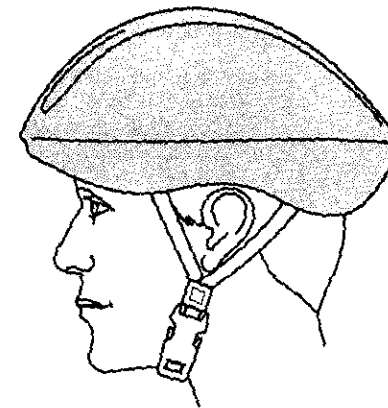

**CORRECT FITTING - MAKE
SURE YOUR HELMET COVERS
YOUR FOREHEAD.**

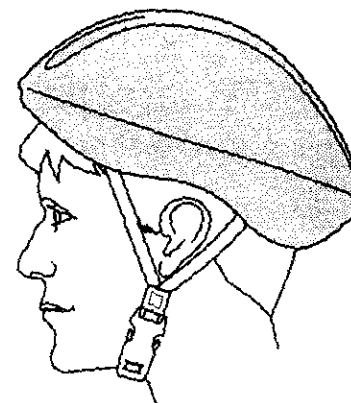

**INCORRECT FITTING. FOREHEAD
IS EXPOSED AND VULNERABLE
TO SERIOUS INJURY.**



Personal Care from Pacific Cycle

(800) 283-3303

Congratulations on your new bike!

*Our Service Department is dedicated
to your satisfaction with Pacific Cycle.*

*We want to help with any questions
or comments you may have.*

*You can also reach us by email at:
service@pacific-cycle.com.*



***DO NOT Return this Product to the Store.
Please Call Pacific Cycle for Assistance.***



The following manual is only a guide to assist you and is not a complete or comprehensive manual of all aspects of maintaining and repairing your bicycle. The bicycle you have purchased is a complex object. **Pacific Cycle** recommends that you consult a bicycle specialist if you have doubts or concerns as to your experience or ability to properly assemble, repair, or maintain your bicycle. You will save time and the inconvenience of having to go back to the store if you choose to write or call us concerning missing parts, service questions, operating advice, and/or assembly questions.

PACIFIC SERVICE

CALL TOLL FREE 1-800-283-3303

Monday - Friday 8:00 a.m. to 4:30 p.m. Central Time

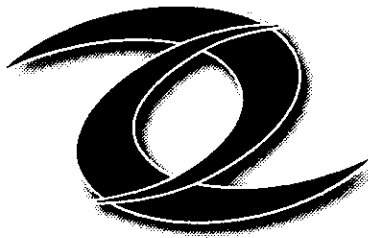





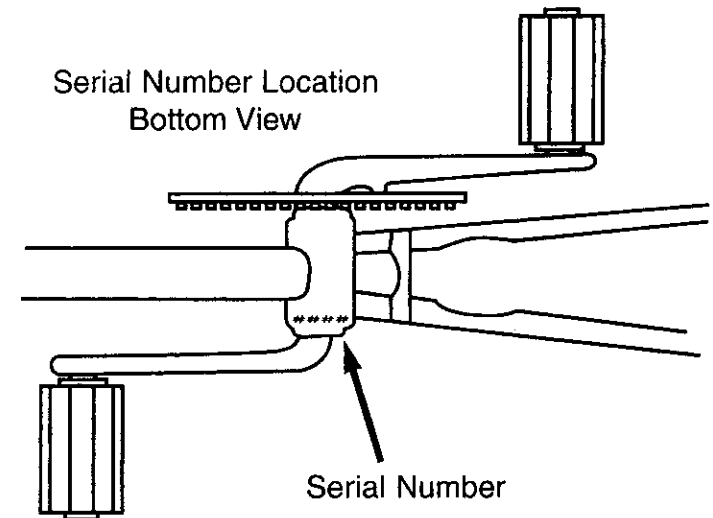



PACIFIC CYCLE LLC

4902 Hammersley Road
Madison, WI 53711
Phone 608/268-2456
Fax 608/268-2455
Customer Service 1-800-283-3303
E-mail: service@pacific-cycle.com
Web Address: www.pacific-cycle.com



DIRECTORY

	PART 1
	PART 2
	PART 3
	PART 4
	PART 5
	PART 6
	PART 7
	PART 8

Parts Identification	1-2
Before You Ride	3-17
Assembly	18-50
Servicing	51-53
Detailed Maintenance	54-85
Purchase Record	86
Warranty.....	87
Contact Addresses	87, BACK COVER



Warning / Important

Take notice of this symbol throughout this manual and pay particular attention to the instructions blocked off and preceded by this symbol.

1. PARTS IDENTIFICATION	1-2	Handlebars	18-20	Hub Bearing Adjustment	56	-Freewheel	77-78
Mountain Bicycles	1	Forks	21	Flat Tire Repair	56-57	-Inspection	77
BMX Bicycles	2	Seat and Seat Post	22	Handlebar Stem	58	-Lubrication	78
Tools Required	3	Pedals & Crank Set	23	Handlebars	59	-Coaster Hub	78
		Front Wheel	24				
		Quick Release Axle	24-25	Grip Shift Installation	60		
2. BEFORE YOU RIDE	3-17	Front Brake	25-32	Cables & Cable Housing	61	Derailleur Systems	79-81
Correct Frame Size	4	-Cantilever with Link Wire	25-26			-Inspection	79
Riding Position	5	-Cantilever with Straddle Cable	27	Headset	62	-Lubrication	80
-Saddle Height	5	-V-Style	27-29	-Inspection	62	-Adjustment (Rear)	80
-Reach	5	-Check your Brakes	30	-Adjustment	62	-Adjustment (Front)	81
-Handlebar Height	6	-Disk Brakes	31-32			Quick Release Levers	82
				Suspension Fork	63	Reflectors	82
Safety Checklist	7-8	Derailleur	33-34	-RST Maintenance	63	Troubleshooting	83-85
-Brakes	7	-Rear Derailleur	33	-RST Reassembly	63		
-Wheels & Tires	7	-Front Derailleur	34	-Check before each ride	63	6. PURCHASE RECORD	86
-Steering	7						
-Chain	8	Dual Suspension	35	Saddle & Seat Post	64-65	7. WARRANTY	87
-Bearings	8	Rear Pivots	36	-Inspection	64		
-Crank & Pedals	8	Accessories	37	-Lubrication	64	8. CONTACT ADDRESS	87, BACK
-Derailleurs	8	Reflectors	37	-Adjustment	65		
-Frame & Fork	8	Final Check	38				
-Accessories	8			Brakes	66-69		
Helmets	9	Single Speed & BMX	39-50	-Inspection	66		
		Handlebars	39	-Lubrication	67		
Riding Safely	10-12	Seat	40	-Adjustment Sidepull Calipers	67		
-General Rules	10	Pedals & Crank Set	40	-Adjustment Cantilever Calipers	68-69		
-Wet Weather Riding	11	Frontwheel	41			Drivetrain	70-78
-Night Riding	11	Front Brake	41	-Pedals	70-71		
-Pedaling Technique	11	Side Pull Brake	42	-Inspection	70		
-Hill Technique	12	Cantilever with Link Wire	42-43	-Lubrication & Adjustment	71		
-Cornering Technique	12	V-Brake	44-45	-Attachment	71		
-Rules for Children	12	Cantilever with Straddle Cable	46			-Crank Set	72-75
		Check your Brakes	47			-Inspection	72
Gears - How to Operate	13-15	Training Wheels	47			-Lubrication & Adjustment	73
-Derailleur Gears	13	Rotors	48-49			(one piece cranks)	73
-Operating Principles	13	Final Check	50			-Lubrication & Adjustment	74-75
-Hand Grip Shifters	14					(cotterless cranks)	74-75
-Thumb Shifters	15	4. SERVICING	51-53				
-Below the Bar Shifters	15	Schedule 1 - Lubrication	51			-Chain	76-77
		Schedule 2 - Service Checklist	52			-Inspection	76
Bicycle Care	16-17	Tools Required	53			-Lubrication	76
-Basic Maintenance	16					-Adjustment & Replacement	76-77
-Storage	17	5. DETAILED MAINTENANCE	54-85				
-Security	17	Wheel Inspection	54				
		Tire Inspection	55				
3. ASSEMBLY	18-50	Tire Pressures	55				
Derailleur Geared Bicycle	18-38						



PART 1 - PARTS IDENTIFICATION

Mountain Bicycles . Mountain bicycles are designed to give maximum comfort over a wide variety of road surfaces. The wider handlebars and convenient shift lever position make them very easy to control. Wider rims and tires give them a softer ride with more traction on rough surfaces. The frame and fork on mountain style bicycles are much sturdier than those on racing style bicycles.

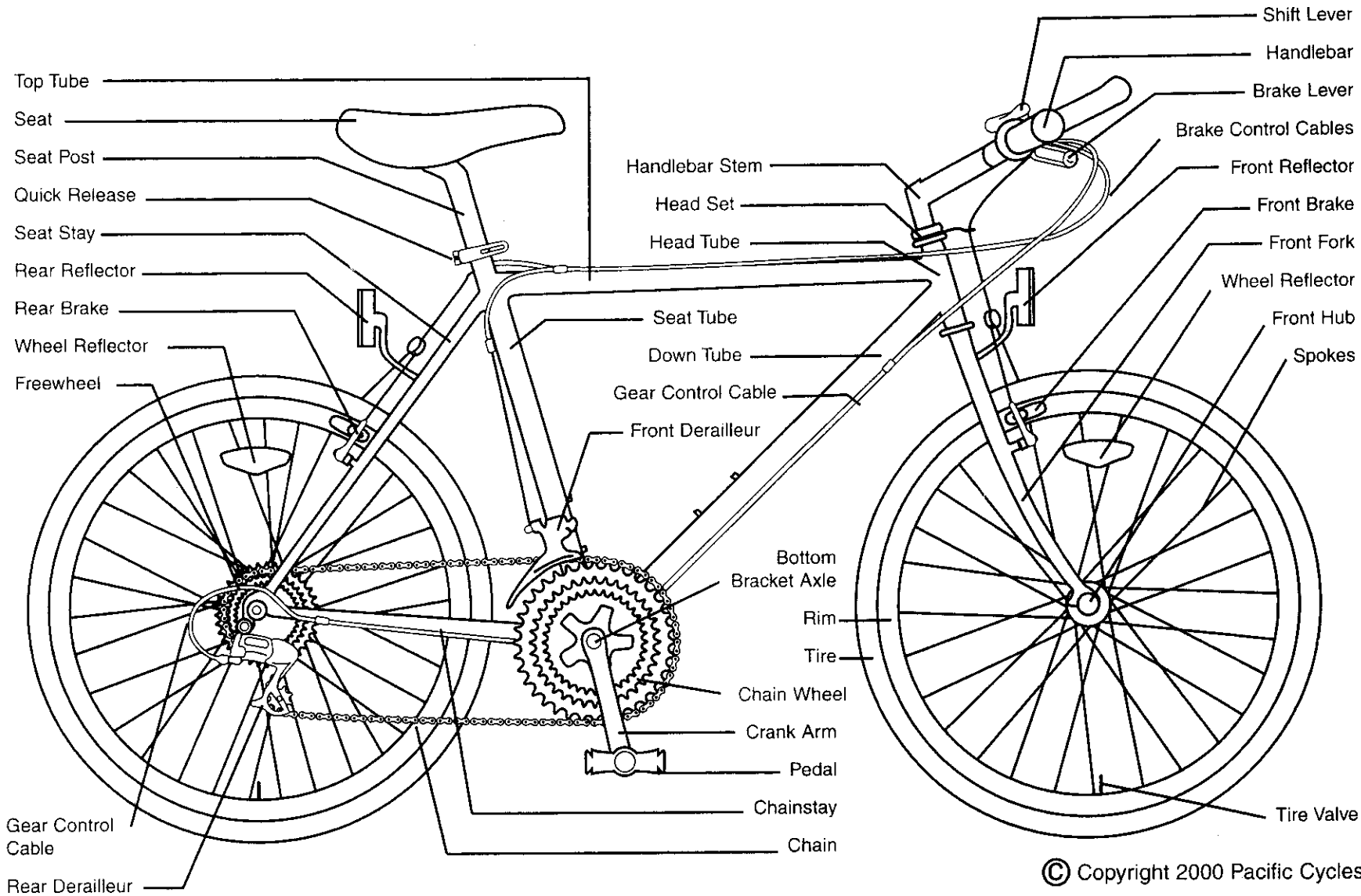

© Copyright 2000 Pacific Cycles

BMX Bicycles . BMX style bicycles are a popular general purpose type most suited for young riders. They are valued because of their sturdy and simple construction, and low maintenance.

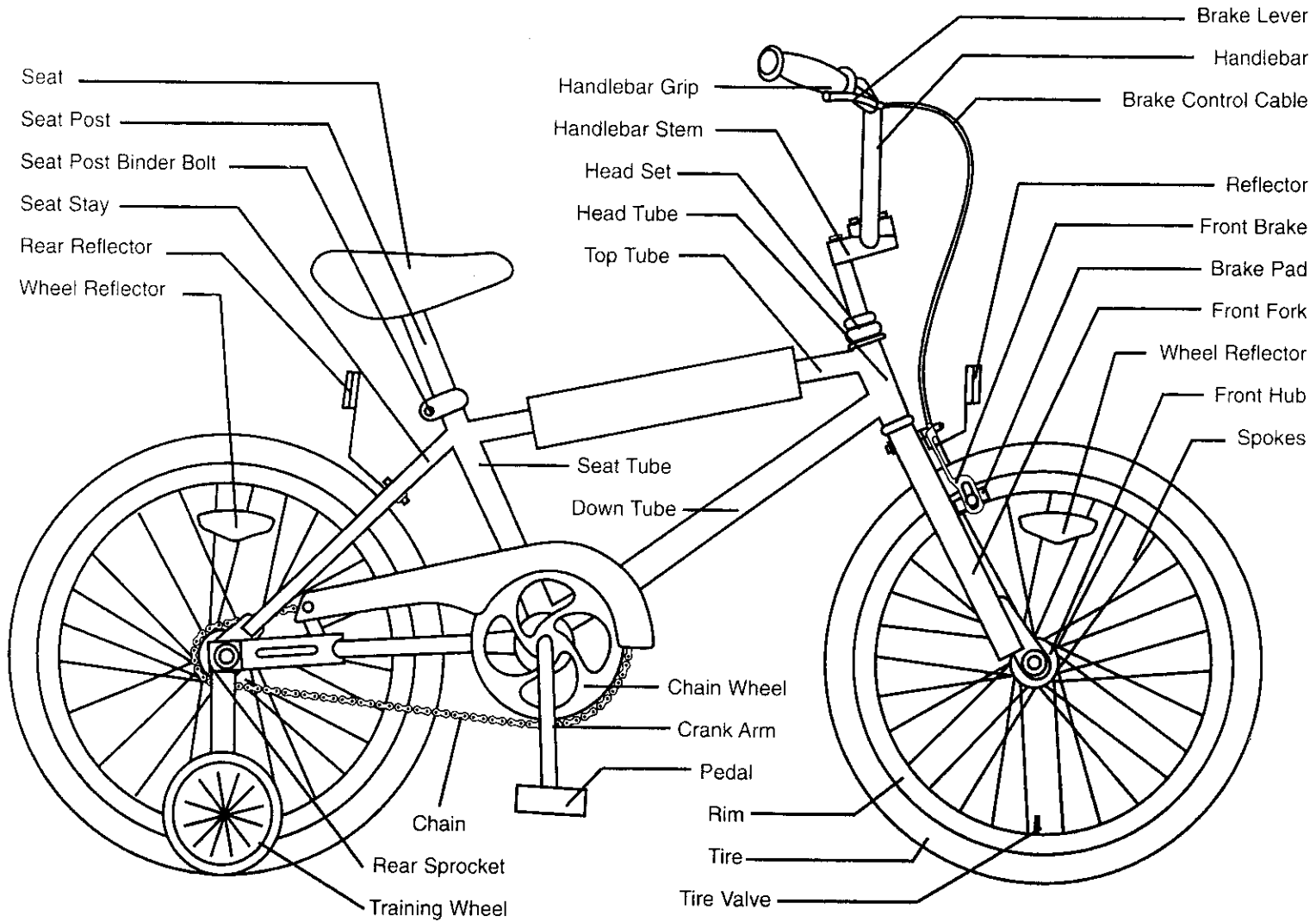

Your new bicycle was assembled and tuned in the factory and then partially disassembled for shipping. You may have purchased the bicycle already fully re-assembled and ready to ride OR in the shipping carton in the partially disassembled form. The following instructions will enable you to prepare your bicycle for years of enjoyable cycling. For more details on inspection, lubrication, maintenance and adjustment of any area please refer to the relevant sections in this manual. If you need replacement parts or have questions pertaining to assembly of your bicycle, call **Pacific** direct at:

PACIFIC SERVICE AND TECHNICAL SUPPORT:

1-800-283-3303

Monday - Friday 8:00 a.m. - 4:30 p.m. Central Time.

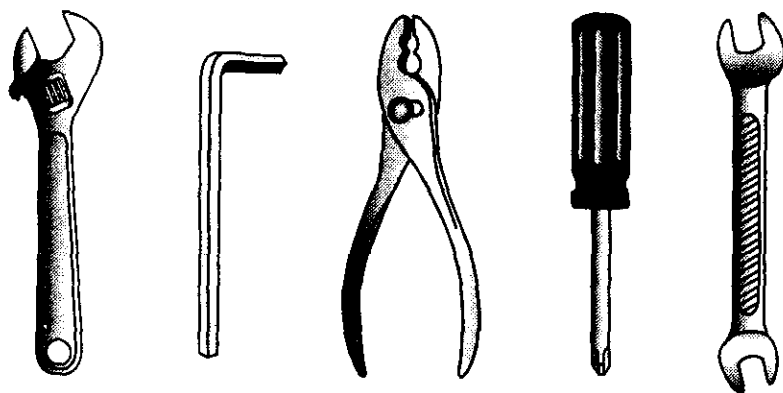

Tools Required:

Phillips head screw driver; 4mm, 5mm
6mm & 8mm Allen keys; adjustable
wrench or a 9mm, 10mm, 14mm & 15mm
open and box end wrenches; and a pliers
with cable cutting ability.



To avoid injury, this product must be properly assembled before use. If your bicycle was obtained assembled, we strongly recommend that you review the complete assembly instructions, and perform checks specified in this manual before riding.



CORRECT FRAME SIZE

When selecting a new bicycle, the correct choice of frame size is a very important safety consideration. Most full sized bicycles come in a range of frame sizes. These sizes usually refer to the distance between the center of the bottom bracket and the top of the frame seat tube.



For safe and comfortable riding there should be a clearance of between 25mm and 50mm between the groin area of the intended rider and the top tube of the bicycle frame, while the rider straddles the bicycle with both feet flat on the ground.

The ideal clearance will vary between types of bicycles and rider preference. This makes straddling the frame when off the saddle easier and safer in situations such as sudden traffic stops. Women can use a men's style bicycle to determine the correct size women's model.

The following chart and diagram will help you make the correct choice.

Frame Sizing Guide

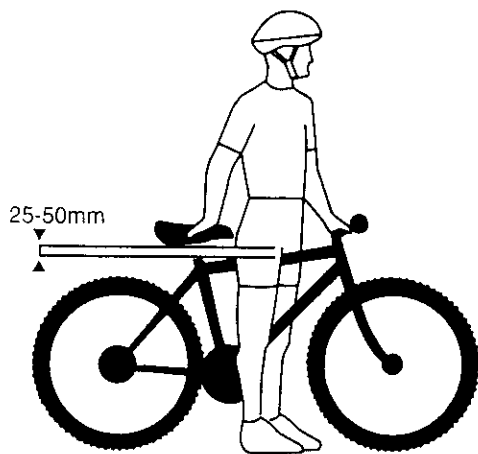

Approximate Rider Leg Length	Suggested Frame Size for Racing/Touring Bicycle	Suggested Frame Size for Mountain or Hybrid Bicycle
61-69cm / 24-27 inches	-	37cm / 14.5 inches
66-76cm / 26-30 inches	-	43cm / 17 inches
71-79cm / 28-31 inches	50cm / 19.5 inches	45cm / 18 inches
76-84cm / 30-33 inches	55cm / 21.5 inches	50cm / 19.5 inches
79-86cm / 31-34 inches	57cm / 22.5 inches	52cm / 20.5 inches
81-89cm / 32-35 Inches	60cm / 23.5 Inches	53-56cm / 21-22 Inches
86-94cm / 34-37 inches	63cm / 25 inches	58-60cm / 23-23.5 inches

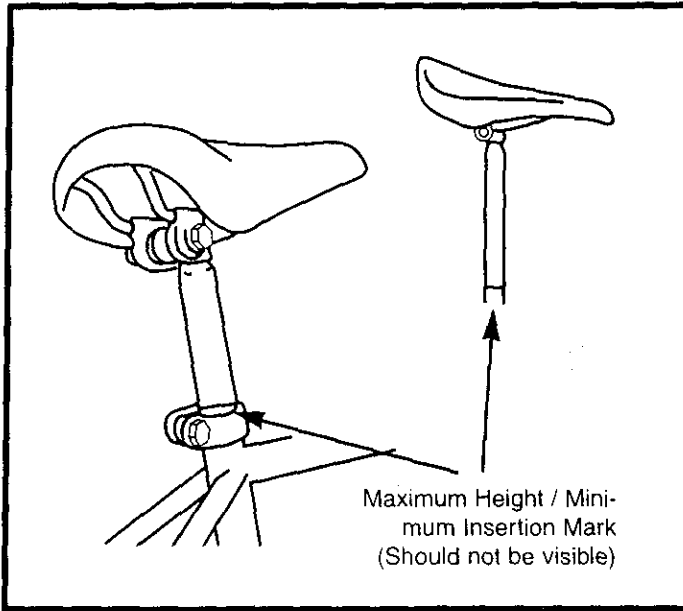

RIDING POSITION

Saddle Height

In order to obtain the most comfortable riding position and offer the best possible pedaling efficiency, the seat height should be set correctly in relation to the rider's leg length. The correct saddle height should not allow leg strain from over-extension, and the hips should not rock from side to side while pedaling. While sitting on the bicycle with one pedal at its lowest point, place the ball of your foot on that pedal. The correct saddle height will allow the knee to be slightly bent in this position. If the rider then places the heel of that foot on the pedal, the leg should be almost straight.

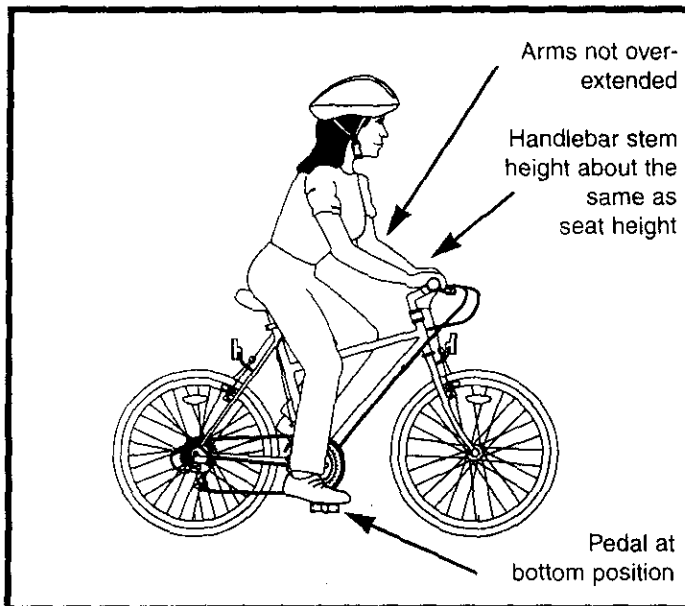

Ensure that the seat pillar does not extend beyond the minimum insertion mark.
(Refer to p. 65 on how to adjust seat height.)

Reach

To obtain maximum comfort, the rider should not overextend his or her reach when riding.

To adjust this distance, the position of the seat can be altered in relation to the seat pillar. (Refer to p. 65 on how to adjust the seat clamp.)

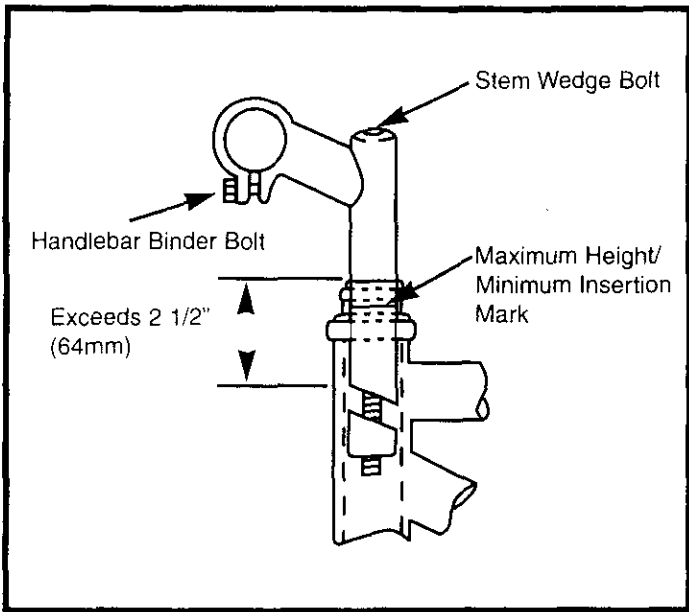

Handlebar Height

Maximum comfort is usually obtained when the handlebar height is equal to the height of the seat. You may wish to try different heights to find the most comfortable position.



Ensure that the handlebar stem does not extend beyond the minimum insertion mark. Failure to do this may cause serious bodily injury or damage to the bicycle. Ensure both the Stem Wedge Bolt and the Handlebar Binder Bolt are tightened securely. Failure to do this may cause loss of steering control. (Refer to p. 59 on how to adjust handlebars).

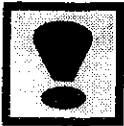

Warning: Overtightening the stem bolt or headset assembly may cause damage to the bicycle and/or injury to the rider.



SAFETY CHECKLIST

Before every ride, it is important to carry out the following safety checks:



1. Brakes

- Ensure front and rear brakes work properly.
- Ensure brake shoe pads are not over worn and are correctly positioned in relation to the rims.
- Ensure brake control cables are lubricated, correctly adjusted, and display no obvious wear.
- Ensure brake control levers are lubricated and tightly secured to the handlebar.



2. Wheels and Tires

- Ensure tires are inflated to within the maximum recommended limit as displayed on the tire sidewall.
- Ensure tires have tread and have no bulges or excessive wear.
- Ensure rims run true and have no obvious wobbles or kinks.
- Ensure all wheel spokes are tight and not broken.
- Check that axle nuts are tight. If your bicycle is fitted with quick release axles, make sure locking levers are correctly tensioned and in the closed position.



3. Steering

- Ensure handlebar and stem are correctly adjusted and tightened, and allow proper steering.
- Ensure that the handlebars are set correctly in relation to the forks and the direction of travel.
- Check that the head set locking mechanism is properly adjusted and tightened.
- If the bicycle is fitted with handlebar end extensions, ensure they are properly positioned and tightened.



4. Chain

- Ensure chain is oiled, clean and runs smoothly.
- Extra care is required in wet or dusty conditions.

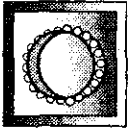

5. Bearings

- Ensure all bearings are lubricated, run freely and display no excess movement, grinding or rattling.
- Check headset, wheel bearings, pedal bearings and bottom bracket bearings.



6. Cranks and Pedals

- Ensure pedals are securely tightened to the cranks.
- Ensure cranks are securely tightened to the axle and are not bent.



7. Derailleurs

- Check that front and rear mechanisms are adjusted and function properly.
- Ensure control levers are securely attached.
- Ensure derailleurs, shift levers and control cables are properly lubricated.



8. Frame and Fork

- Check that the frame and fork are not bent or broken.
- If either are bent or broken, they should be replaced.



9. Accessories

- Ensure that all reflectors are properly fitted and not obscured.
- Ensure all other fittings on the bike are properly and securely fastened, and functioning.
- Ensure the rider is wearing a helmet.



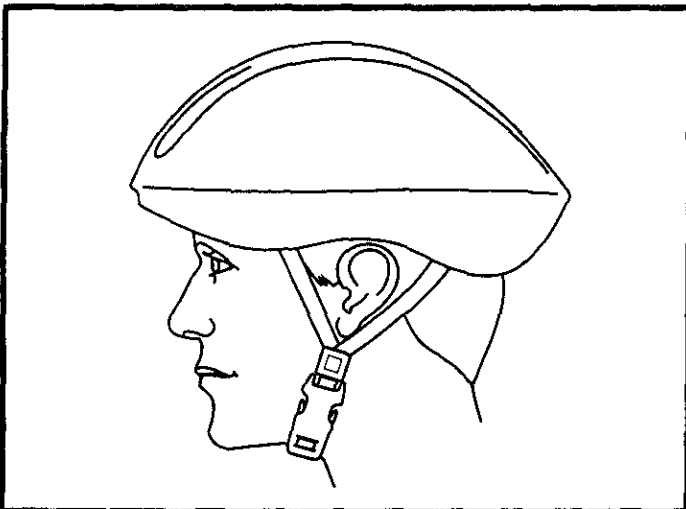

Helmets

It is strongly advised that a properly fitting, ANSI or SNELL approved, bicycle safety helmet be worn at all times when riding your bicycle. In addition, if you are carrying a passenger in a child safety seat, they must also be wearing a helmet.

The correct helmet should:

- be comfortable
- be lightweight
- have good ventilation
- fit correctly



Always wear a properly fitted helmet when riding a bicycle.

RIDING SAFELY

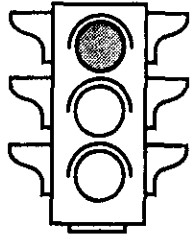

General Rules

When riding obey the same road laws as all other road vehicles, including giving way to pedestrians, and stopping at red lights and stop signs.

For further information, contact the Road Traffic Authority in your State.

Ride predictably and in a straight line. Never ride against traffic.

Use correct hand signals to indicate turning or stopping.

Ride defensively. To other road users, you may be hard to see.

Concentrate on the path ahead. Avoid pot holes, gravel, wet road markings, oil, curbs, speed bumps, drain grates and other obstacles.

Cross train tracks at a 90 degree angle or walk your bicycle across.

Expect the unexpected such as opening car doors or cars backing out of concealed driveways.

Be extra careful at intersections and when preparing to pass other vehicles.

Familiarize yourself with all the bicycle's features. Practice gear shifts, braking, and the use of toe clips and straps, if fitted.

If you are wearing loose pants, use leg clips or elastic bands to prevent them from being caught in the chain.

Don't carry packages or passengers that will interfere with your visibility or control of the bicycle. Don't use items that may restrict your hearing.

When braking, always apply the rear brake first, then the front. The front brake is more powerful and if it is not correctly applied, you may lose control and fall.

Maintain a comfortable stopping distance from all other riders, vehicles and objects. Safe braking distances and forces are subject to the prevailing weather conditions.

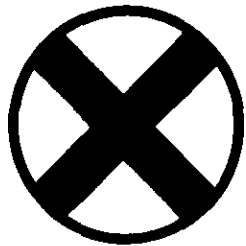
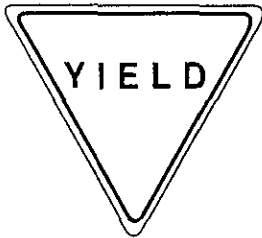
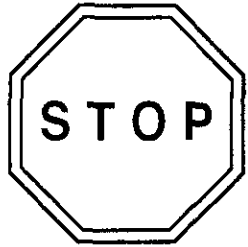



Wet Weather

- In wet weather you need to take extra care.
- Brake earlier, you will take a longer distance to stop.
- Decrease your riding speed, avoid sudden braking, and take corners with additional caution.
- Be more visible on the road.
- Wear reflective clothing and use safety lights.
- Pot holes and slippery surfaces such as line markings and train tracks all become more hazardous when wet.

Night Riding



Do not ride at night

- Ensure bicycle is equipped with a full set of correctly positioned and clean reflectors.
- Refer to p. 84 of this manual.
- Use a properly functioning lighting set comprising a white front lamp and a red rear lamp.
- If using battery powered lights, make sure batteries are well charged.
- Some rear lights available have a flashing mechanism which enhances visibility.
- Wear reflective and light colored clothing.
- Ride at night only if necessary. Slow down and use familiar roads with street lighting, if possible.

Pedaling Technique

- Position the ball of your foot on the center of the pedal.
- When pedaling, ensure your knees are parallel to the bicycle frame.
- To absorb shock, keep your elbows slightly bent.
- Learn to operate the gears properly. (Refer to p. 13-15)



Hill Technique

- Gear down before a climb and continue gearing down as required to maintain pedaling speed.
- If you reach the lowest gear and are struggling, stand up on your pedals. You will then obtain more power from each pedal revolution.
- On the descent, use the high gears to avoid rapid pedaling.
- Do not exceed a comfortable speed, maintain control and take additional care.

Cornering Technique

Brake slightly before cornering and prepare to lean your body into the corner. Maintain the inside pedal at the 12 o'clock position and slightly point the inside knee in the direction you are turning. Keep the other leg straight, don't pedal through fast or tight corners.

Rules for Children

To avoid accidents, teach children good riding skills with an emphasis on safety from an early age.

1. Always wear a properly fitted helmet.
2. Do not play in driveways or the road.
3. Do not ride on busy streets.
4. Do not ride at night.
5. Obey all the traffic laws, especially stop signs and red lights.
6. Be aware of other road vehicles behind and nearby.
7. Before entering a street: Stop, look right, left, and right again for traffic.
If there's no traffic, proceed into the roadway.
8. If riding downhill, be extra careful. Slow down using the brakes and maintain control of the steering.
9. Never take your hands off the handlebars, or your feet off the pedals when riding downhill.



The Consumer Protection Safety Commission advises that the riding of small wheel diameter bicycles at excessive speeds can lead to instability and is not recommended.

Children should be made aware of all possible riding hazards and correct riding behavior before they take to the streets
- Do not leave it up to trial and error.

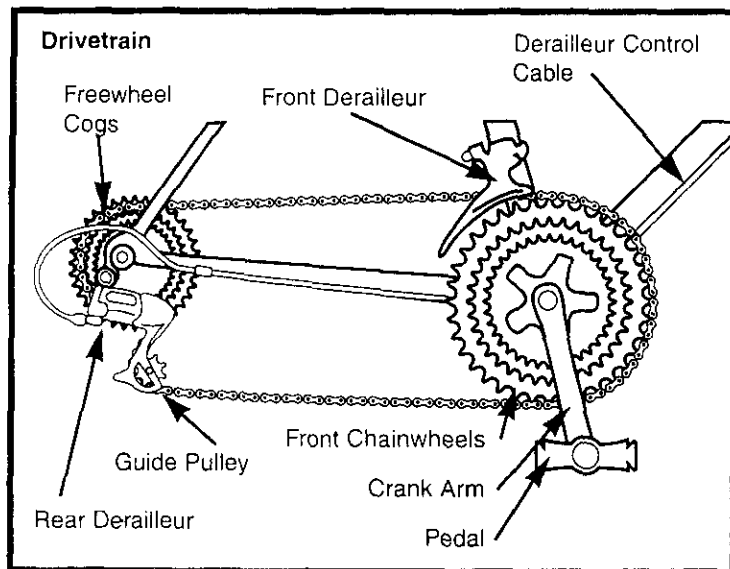

GEARS - HOW TO OPERATE

Derailleur Gears

Most multi-speed bicycles today are equipped with what are known as derailleur gears. They operate using a system of levers and mechanisms to move the drive chain between different sized driving gears or cogs. The purpose of gears is to let you maintain a constant, steady pedaling pace under varying conditions. This means your riding will be less tiring without unnecessary straining up hills or fast pedaling down hill. Bicycles come with a variety of gear configurations from 5 to 24 speeds. A 5-6 speed bicycle will have a single front chainwheel, a rear derailleur, and 5 or 6 cogs on the rear hub. Bicycles with more gears will also have a front derailleur, a front chainwheel with 2-3 cogs, and up to 8 cogs on the rear hub.

Operating Principles

No matter how many gears, the operating principles are the same. The front derailleur is operated by the left shift lever and the rear derailleur by the right. To operate you must be pedaling forward. You can not shift derailleur gears when you are stopped or when pedaling backwards. Before shifting ease up on your pedaling pressure. On approaching a hill, shift to a lower gear before your pedaling speed slows down too much for a smooth shift. When coming to a stop, shift to a lower gear first so it will be easier when you start riding again. If, after selecting a new gear position, you hear a slight rubbing noise from the front or rear gears, gently adjust the appropriate shifter until the noise goes away. For optimal performance and extended chain life, it is recommended that you avoid using the extreme combinations of gear positions (diagram p. 14) for extended periods.

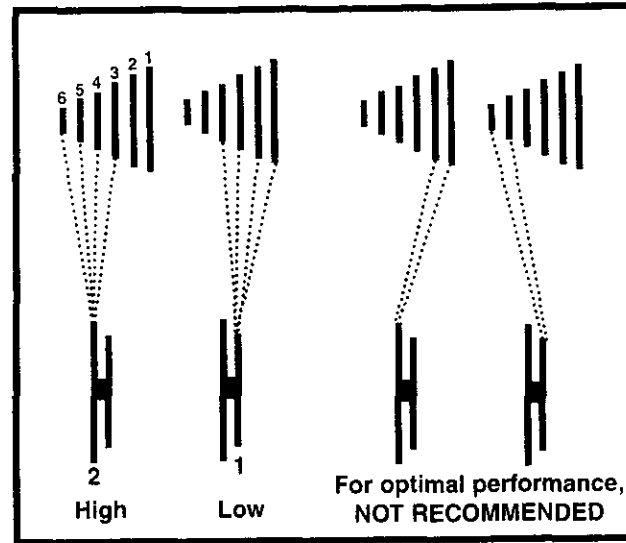
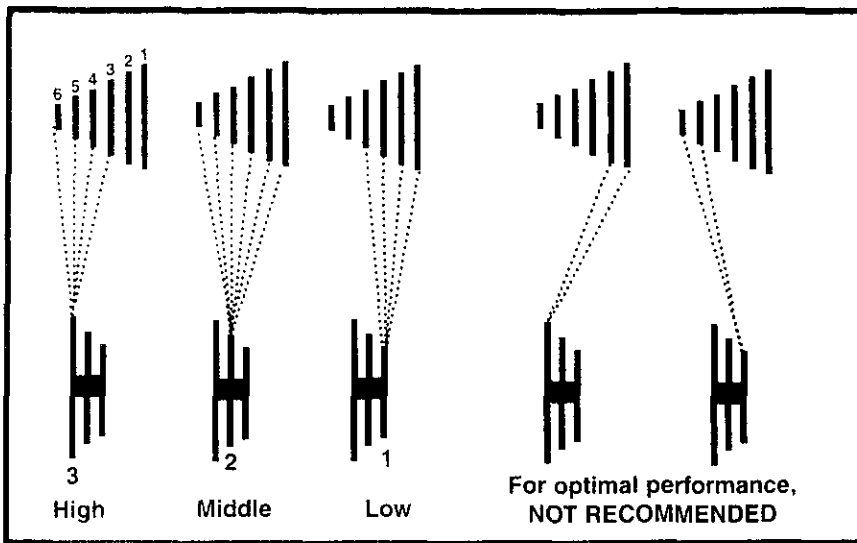

Recommended Chainwheel/Rear Sprocket Gear Combinations

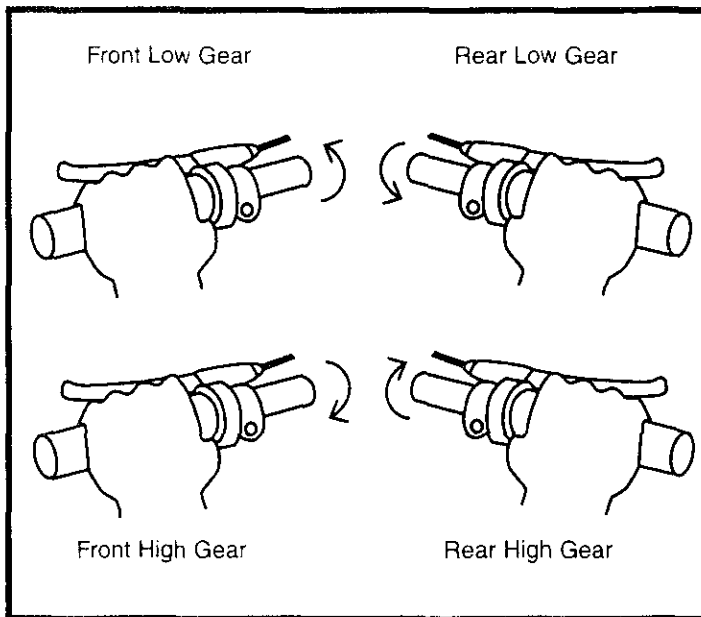

Hand Grip Shifters

Some bicycles are now being equipped with a shifting mechanism called Grip Shift, which is built into the handlebar grips and does not make use of separate levers. The actuating mechanism is built into the inside part of the grip that the web of the thumb and index finger closes around. To select a lower gear, twist the right shifter toward you to engage a larger rear cog. You can shift one gear at a time by moving the Grip Shift one click, or through multiple gears by continued twisting. By twisting the left shifter forward or away from you, a smaller chainwheel can be selected. To select a higher gear, twist the right shifter forward or away from you to engage a smaller rear cog. To engage a larger front chainwheel, twist the left shifter towards you. Single shifts can be achieved by twisting one click at a time and multiple shifts by larger twists.

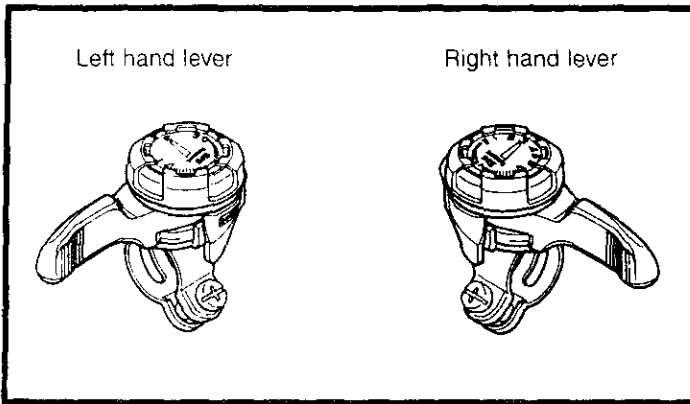

Thumb Shifters (Top Mounted)

Most mountain style bicycles are equipped with shifters mounted on the top of the handlebars and operated by the thumbs. To select a lower, easier gear, shift to a bigger rear cog and a small chainwheel. Pull the left shifter back to operate the front derailleur, and push the right shifter forward to operate the rear derailleur. To select a higher, harder gear, shift to a smaller rear cog and a larger chainwheel. Push the left shifter forward for the front, and pull the right lever back for the rear.

Top Gear (Harder) Small rear sprocket Large chainwheel Left hand lever forward Right hand lever back

Bottom Gear (Easier) Large rear sprocket Small chainwheel Left hand lever back Right hand lever forward
--

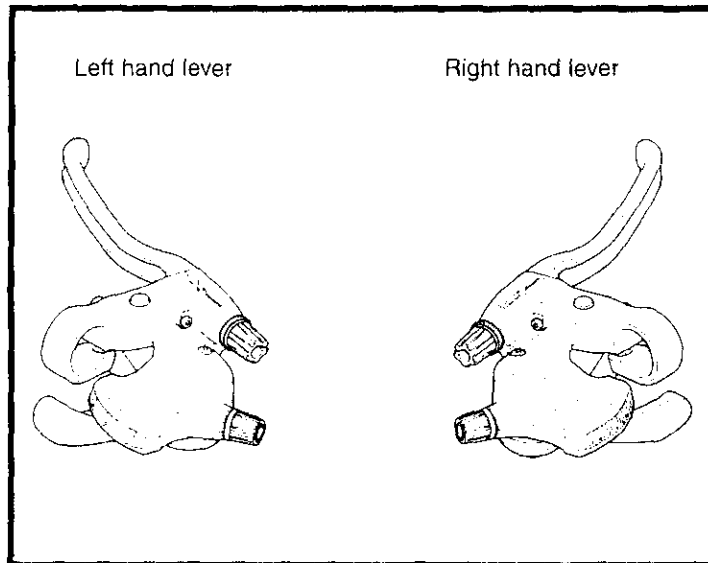

Below the Bar Shifters

Many mountain style bicycles now use a shift lever arrangement mounted on the underside of the handlebars, which use two levers operated by the thumb and index finger. To select a lower gear push the larger (lower) right shifter with your thumb to engage a larger rear cog. One firm push shifts the chain one cog, continuing to push will move the chain over multiple cogs. Pulling the smaller (upper) left shifter with your index finger moves the chain from a larger to a smaller chainwheel. To select a higher gear pull the smaller (upper) right lever with your index finger to engage a smaller rear cog. Pushing the larger (lower) left lever with your thumb will move the chain from a smaller to a larger chainwheel.

BICYCLE CARE

Basic Maintenance

The following procedures will help you maintain your bicycle for years of enjoyable riding.

For painted frames, dust the surface and remove any loose dirt with a dry cloth. To clean, wipe with a damp cloth soaked in a mild detergent mixture. Dry with a cloth and polish with car or furniture wax. Use soap and water to clean plastic parts and rubber tires. Chrome plated bikes should be wiped over with a rust preventative fluid.

Store your bicycle under shelter. Avoid leaving it in the rain or exposed to corrosive materials. Riding on the beach or in coastal areas exposes your bicycle to salt which is very corrosive. Wash your bicycle frequently and wipe or spray all unpainted parts with an anti-rust treatment. Make sure wheel rims are dry so braking performance is not affected. After rain, dry your bicycle and apply anti-rust treatment.

If the hub and bottom bracket bearings of your bicycle have been submerged in water, they should be taken out and re-greased. This will prevent accelerated bearing deterioration.

If paint has become scratched or chipped to the metal, use touch up paint to prevent rust. Clear nail polish can also be used as a preventative measure.

Regularly clean and lubricate all moving parts, tighten components and make adjustments as required. (Refer to Parts 4 and 5 of this manual for further details).

The use of alloy components and BED, SATIN, and TITANIUM surface treatments minimizes the number of places where rust can surface.





Storage

Keep your bicycle in a dry location away from the weather and the sun. Ultraviolet rays may cause paint to fade or rubber and plastic parts to crack.

Before storing your bicycle for a long period of time, clean and lubricate all components and wax the frame. Deflate the tires to half pressure and hang the bicycle off the ground. Don't store near electric motors as ozone emissions may effect the rubber and paint. Don't cover with plastic as "sweating" will result which may cause rusting.

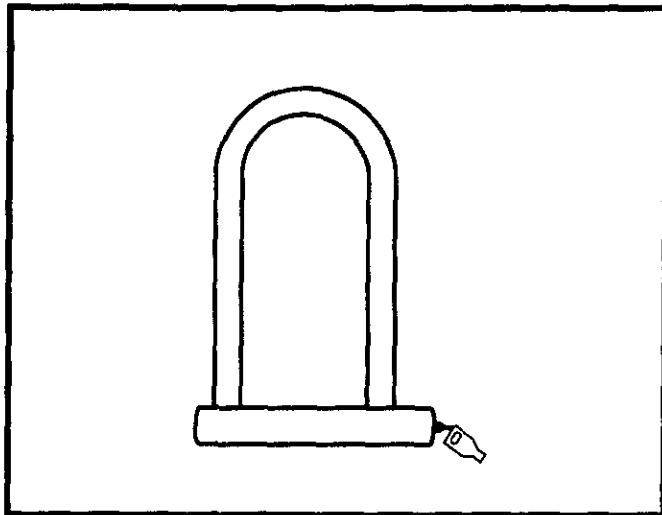

Security

It is advisable that the following steps be taken to prepare for and help prevent possible theft.

1. Maintain a record of the bicycle's serial number, generally located on the frame underneath the bottom bracket.
2. Register the bicycle with the local police.
3. Invest in a high quality bicycle lock that will resist hack saws and bolt cutters. Always lock your bicycle to an immovable object if it is left unattended.

DERAILLEUR GEARED BICYCLES

Includes 20", 24" and 26" Wheel Mountain Bikes
Assembly is the same for men's and women's bikes.

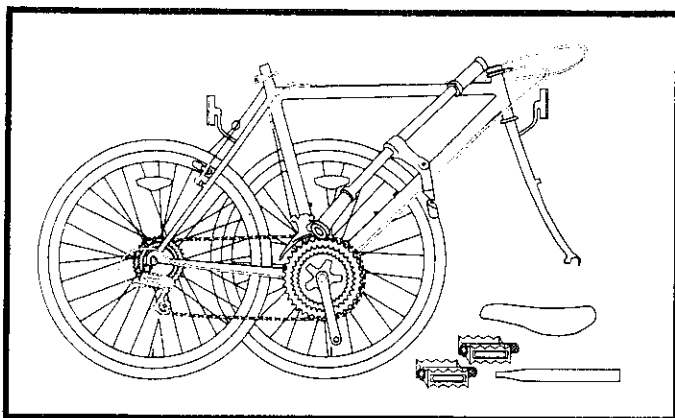

Getting Started

Open the carton from the top and remove the bicycle. Remove the straps and protective wrapping from the bicycle. Inspect the bicycle and all accessories and parts for possible shortages. It is recommended that the threads and all moving parts in the parts package be lubricated prior to installation. Do not discard packing materials until assembly is complete to insure that no required parts are accidentally discarded. Assemble your bicycle following the steps that pertain to your model. **Note: Your bicycle may be equipped with different style components than the ones illustrated.**

Handlebars

Remove the protective cap from the handlebar stem wedge and loosen the Allen key bolt using the 6mm Allen key. Some models may use a 13mm hexagonal bolt instead of an Allen key bolt. Place the handlebar stem into the top of the head tube, ensuring that all cables are free of tangles. Tighten the stem bolt observing the minimum insertion mark and checking that the forks and the handlebars are facing forward. Check the headset for smooth rotation and that the top nut is secured tightly. Loosen the 6mm Binder Bolt and rotate the handlebar forward so the levers are at a 45 degree angle below the handlebar. Retighten the Binder Bolt to ensure the handlebar does not rotate in the stem.

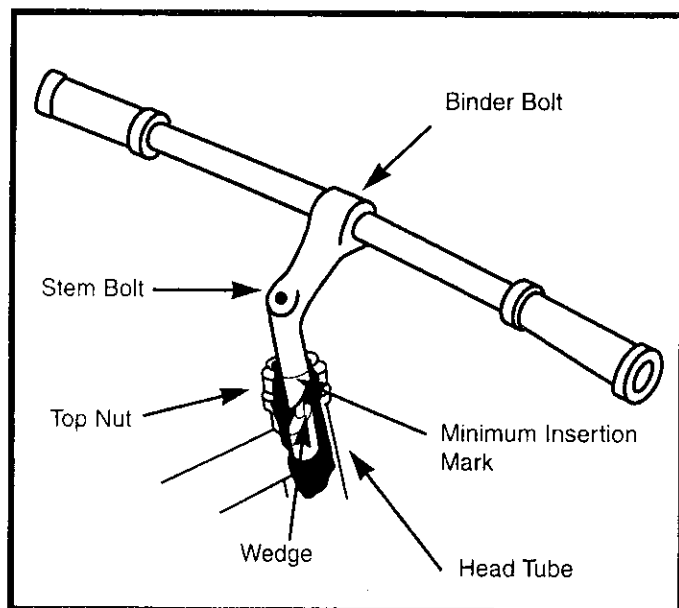

Warning: Overtightening the stem bolt or headset assembly may cause damage to the bicycle and/or injury to the rider.



NOTE: Comfort Series (CS) bicycles may be equipped with a stem that has an adjustable angle. In addition to the normal assembly, these stems will require angling the stem to the desired position, and securely tightening the 6mm angle bolt located in front of the stem bolt.
Failure to do this may cause loss of steering control.



The stem must be inserted so that the minimum insertion mark cannot be seen.

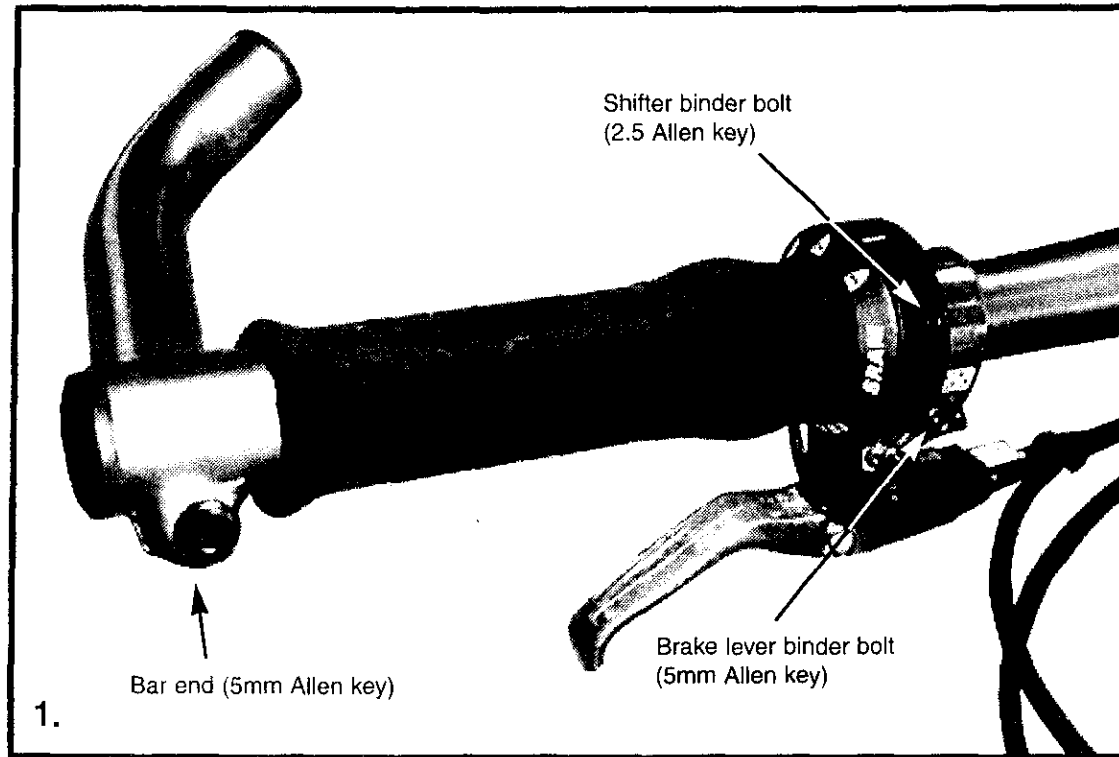

Tighten all bolts that clamp the shifters, brake levers, and bar ends to the handlebar using a 5mm Allen key or Phillips head screwdriver.
 (Figure 1) Handlebar with Grip Shifter.
 (Figure 2) Top mounted thumb shifter.

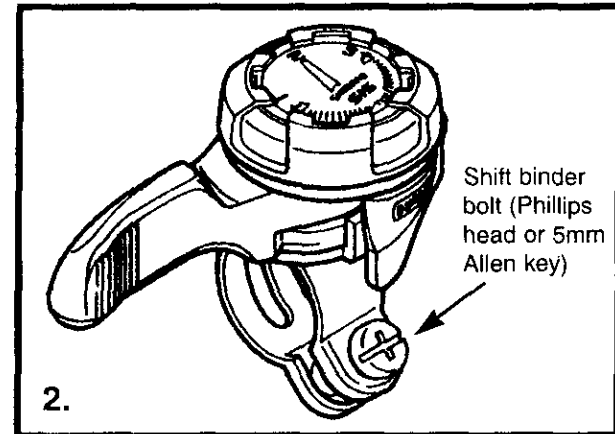

Failure to properly tighten clamping bolts may cause sudden movement of the component resulting in loss of steering control.



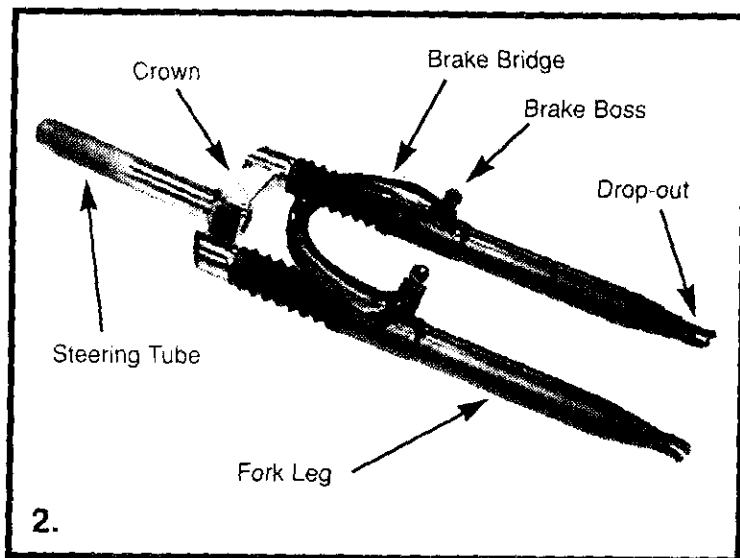
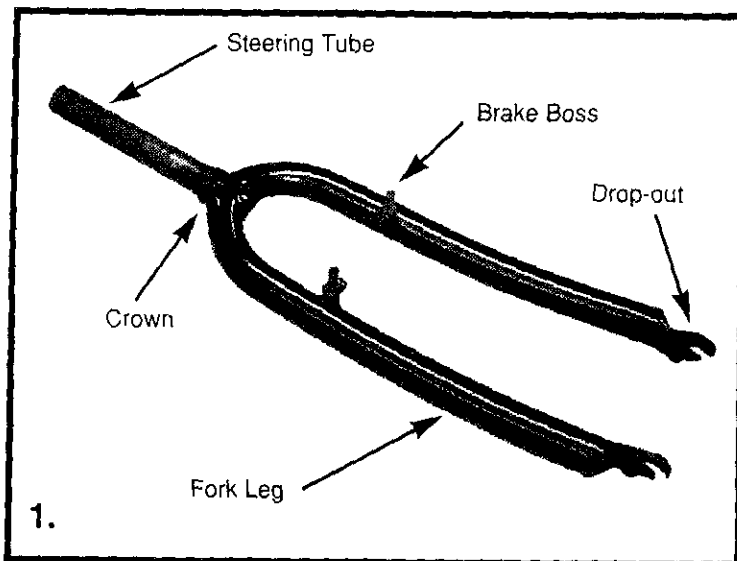

Forks

There are two different types of forks that range in styles and dimensions. One type is a rigid fork (Figure 1) consisting of stationary tubing with curved blades. The other type is a suspension fork (Figure 2) consisting of stanchion tubes riding on elastomers or springs inside of a straight fork leg. This mechanism acts as a shock absorber with a specified amount of travel that varies between models. Most Pacific Cycle suspension forks are not adjustable and are very difficult to disassemble. If service is needed on a suspension fork, consult a professional bicycle repair technician.



Do not attempt to disassemble a suspension fork yourself. Consult a professional bicycle repair technician.

Check the tightness of the headset and the fork. Rotate the fork checking for smoothness. If it feels like the fork is binding, then an adjustment will need to be made to the headset. Move the fork in a push/pull manner checking for tightness. If any play is detected, loosen the top nut, adjust the bearing cup, and retighten the top nut. Recheck the rotation and tightness. If necessary, readjust until a smooth rotation is achieved without backward or forward movement. If your bike is equipped with a suspension fork, check that the fork compresses and rebounds smoothly. To do this, place the fork dropouts against the ground, push and release the handlebar. The fork will generally compress 1-2" and rebound quickly. Most elastomer type forks will gradually soften with use.

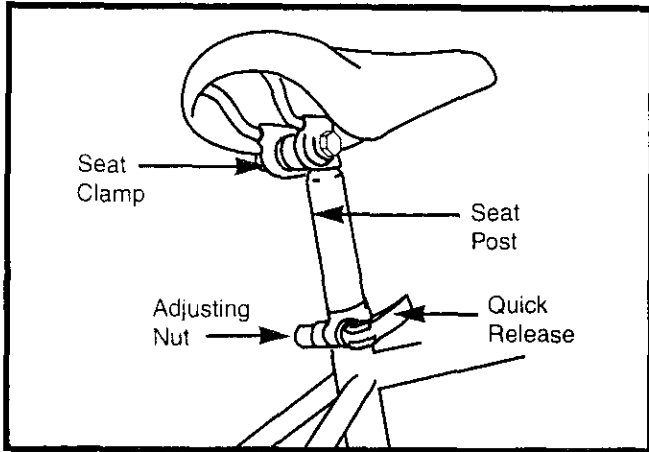

Seat and Seat Post

Attach the seat to the seat post by inserting the smaller end of the seat post into the seat clamp and tighten. Insert the larger end of the seat post into the seat tube of the bicycle frame observing the minimum insertion mark on the seat post. Turn the adjusting nut of the Quick Release seat bolt to ensure the locking lever is moved to the closed position with a firm action. Turn the bicycle upside down and rest it on the seat and handlebars.

NOTE: Comfort Series (CS) bicycles may be equipped with a suspension seat post (See Diagram-bottom left). Some suspension posts can be adjusted for stiffness using the preload adjusting screw. Turning the 6mm Allen screw **Clockwise** will decrease travel and make the suspension stiffer, while turning the 6mm Allen screw **Counter-clockwise** will increase travel and make the suspension less rigid.

Note: In addition to normal assembly, please be aware that the preload adjusting screw must be flush with the bottom of the post.
Failure to do this may cause irreparable damage.

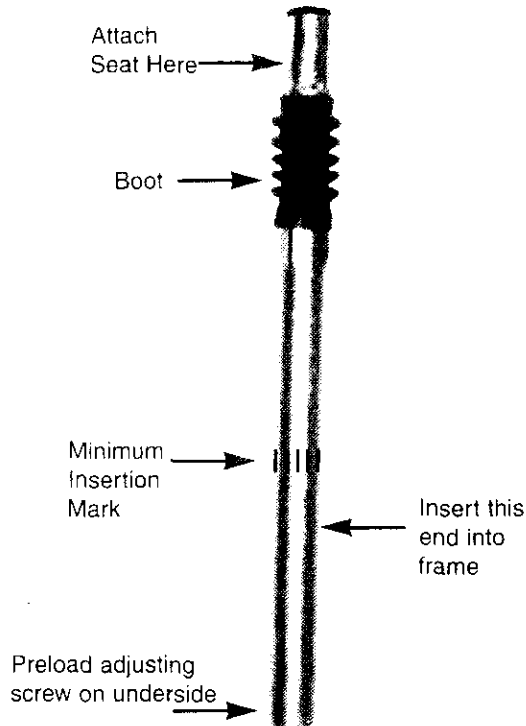

The seat post must be inserted so that the minimum insertion mark cannot be seen. The quick release mechanism must be tightened securely to prevent a sudden shift of the seat when riding. Failure to do this may cause loss of bicycle control.

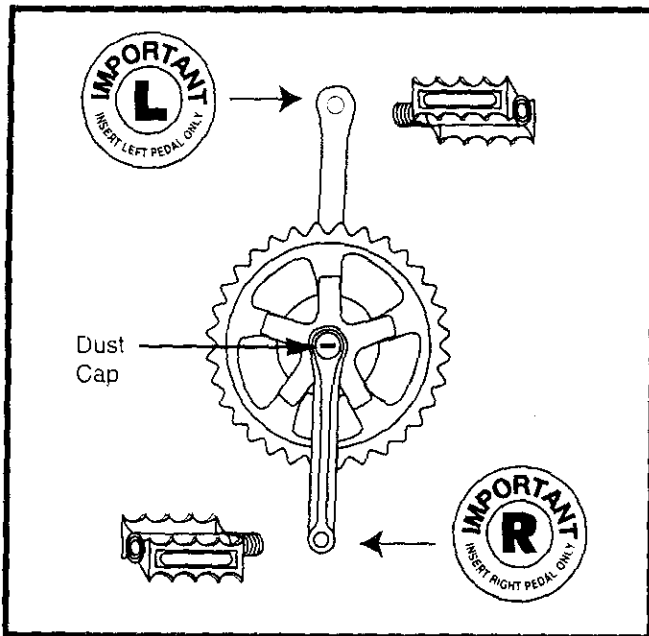

Pedals & Crank Set

Look for the letters "R" for right, and "L" for left, stamped on each pedal spindle. Start each pedal spindle by hand to avoid stripping the threads. Tighten with a 15mm narrow open ended wrench. Note that the right hand pedal attaches to the chainwheel side crank arm with a right-hand (clockwise) thread. The left pedal attaches to the other crank arm and has a left-hand (counter-clockwise) thread. It is very important that you check the crank set for correct adjustment and tightness before riding your bicycle. New cranks may become loose with initial use, refer to p. 74-77 for proper crank set adjustment and maintenance. Once the pedals have been installed, remove the dust caps from the center of each crank arm. Using a 14mm socket wrench, tighten the spindle nuts securely (approx. 350 in. lbs.) and replace the dust caps.



Attachment of an incorrect pedal into a crank arm will cause irreparable damage.

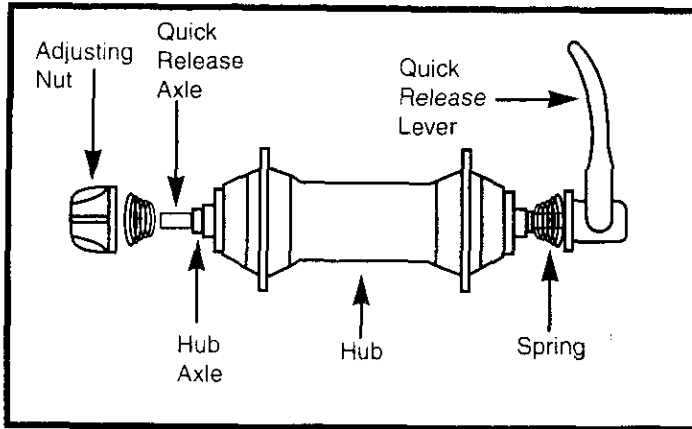

Front Wheel

Check the wheel hub before attaching it to the fork by rotating the threaded axle. It should be smooth with no lateral movement. Insert the front wheel into the fork dropouts. Tighten the wheel nuts using the appropriate 14mm or 15mm wrench. Spin the wheel checking for trueness. Some bicycles have wheel axles that incorporate a Quick Release (QR) mechanism. This allows easy wheel removal without the need for tools. The mechanism uses a long bolt with an adjusting nut on one end, and a lever operating a cam-action tensioner on the other. If the wheel is fitted with a Quick Release type axle, turn the adjusting nut so that the locking lever is moved to the closed position with a firm action. At the halfway closed position of the quick release lever, you should start to feel some resistance to this motion. Do not tighten the quick release by using the quick release lever like a wing nut. If the quick release lever is moved to the closed position with no resistance, clamping strength is insufficient. Move the quick release lever to the open position, tighten the quick release adjusting nut, and return the quick release lever to the closed position.

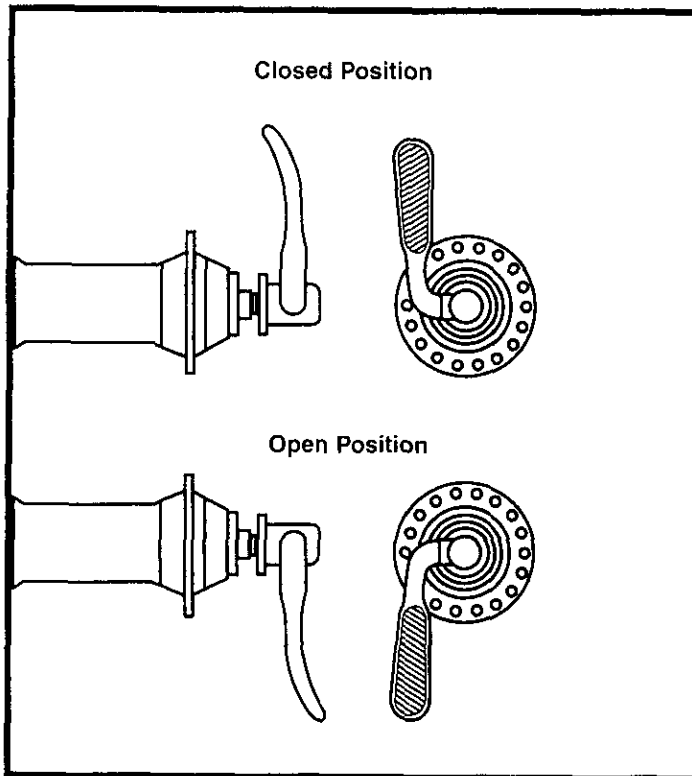

Correct Quick Release Axle Setting

1. To set, turn the lever to the open position so that the curved part faces away from the bicycle.
2. While holding the lever in one hand, tighten the adjusting nut until it stops.
3. Pivot the lever towards the closed position. When the lever is halfway closed, there must be firm resistance to turn it beyond that point. If resistance is not firm, open the lever and tighten the adjusting nut in a clockwise direction.
4. Continue to pivot the lever all the way to the closed position so that the curved part of the lever faces the bicycle.

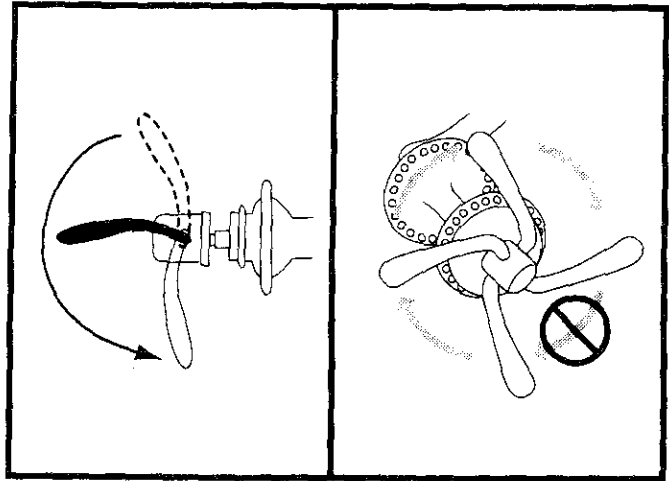

5. The wheel is tightly secured when the serrated surfaces of the quick release clamping parts actually begin to cut into the bicycle frame/fork surfaces.
6. Note that the same procedure applies when operating a quick release seat post binder mechanism.
7. Turn the bicycle upright using the kickstand to support it.



Warning - Correct adjustment of the quick release is vitally important to avoid an accident caused by loose wheels.

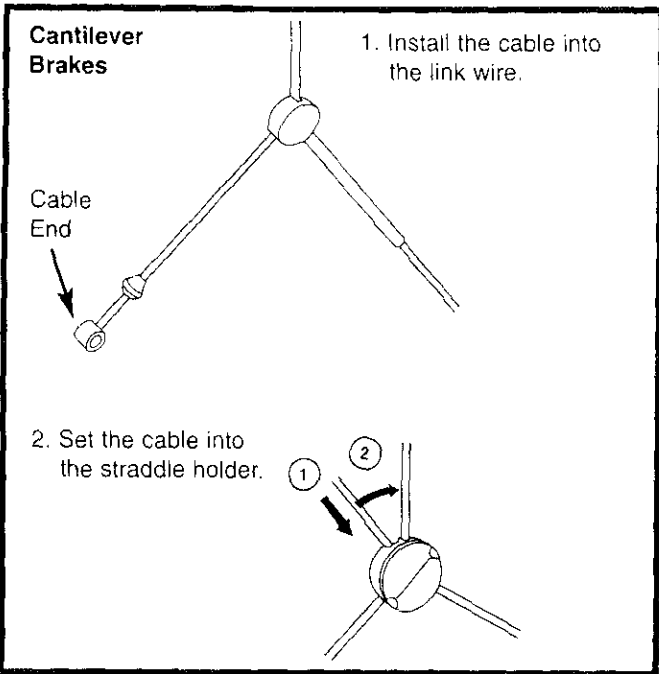

Front Brake

Determine which type of brake your bike is equipped with and refer to the appropriate assembly instructions. For more information on brake adjustment and maintenance, refer to p. 66-69.

Cantilever Brakes - Utilizing a Link Wire

If fitted with cantilever type brakes, insert the brake cable into the link wire lead, and notch the cable end into the slot of the left brake arm. Loosen the anchor bolt on the right brake arm and slide the brake cable under the tabbed washer. Squeeze both brake arms together so the brake shoes hit the rim, pull all slack out of the brake cable, and tighten the anchor bolt. With the cable fitted, the straddle holder should sit 10-20mm above the reflector bracket. Adjust the brake shoes using a 10mm wrench so that they are parallel with the rim and are positioned 1-2mm away from the rim. Several adjustments may be necessary to achieve the correct brake position.

3. Temporarily tighten the cable so that the link wire is at the position in the illustration.

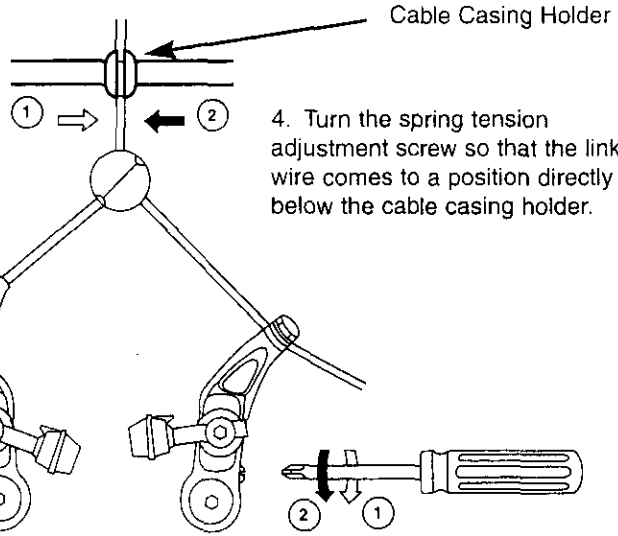
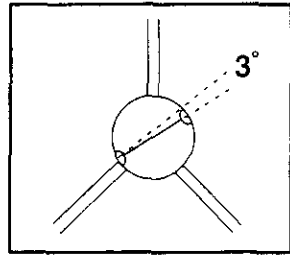
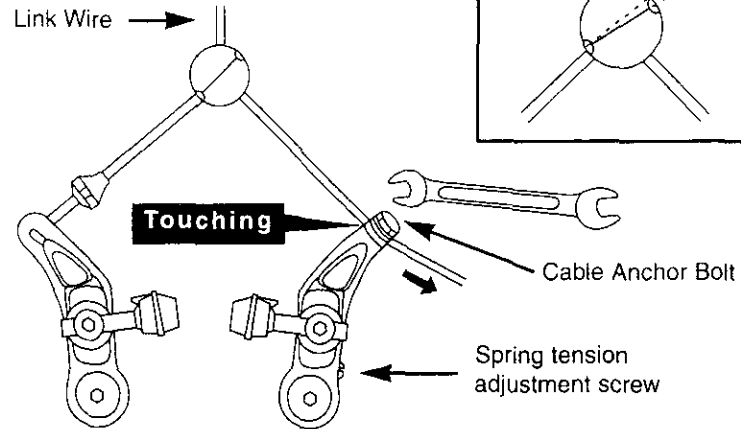

4. Turn the spring tension adjustment screw so that the link wire comes to a position directly below the cable casing holder.

5. Secure one of the shoes at a time. The adjustment of the shoe clearance is not necessary at this time. Shoe fixing nut tightening torque: 7.84 - 8.82 Nm (70 - 78 in. lbs.)

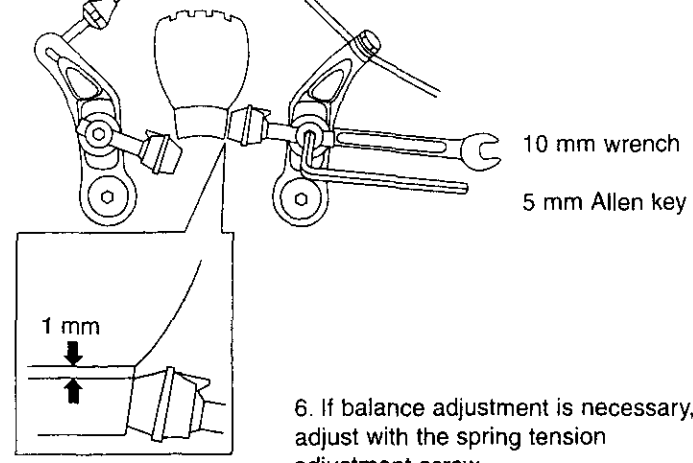

6. If balance adjustment is necessary, adjust with the spring tension adjustment screw.

Cut off any unnecessary cable, attach an end cap, and hook it onto the notched part of the nut which secures the shoe.

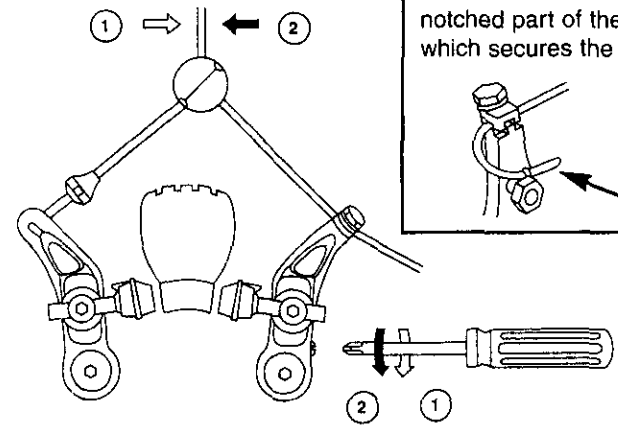

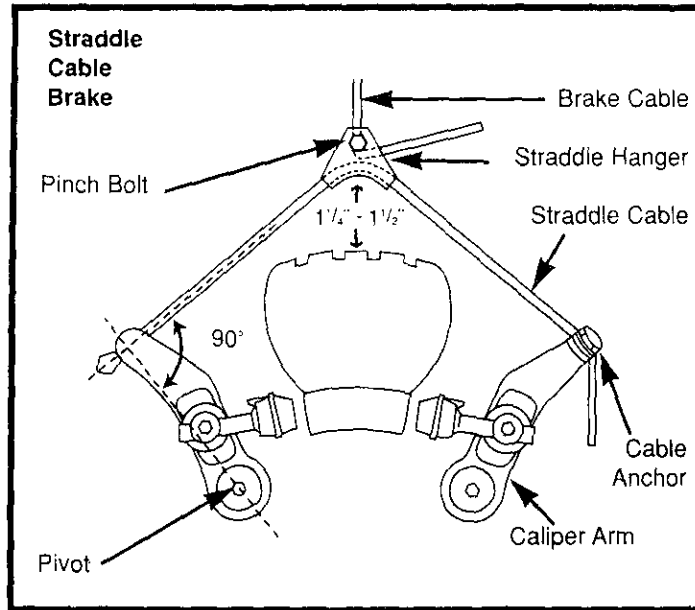

Cantilever Brakes - Utilizing a Straddle Cable

The length of the straddle cable, the height of the straddle hanger, and the brake pad-to-caliper arm position all have an effect on braking power. Generally, the straddle cable bridge is set low and close to the tire for maximum braking force. The straddle cable should be high enough, however, to adequately clear the tire (and any debris that may stick to the tire) or to fit over the front reflector hanger. In the event of brake cable failure, the front reflector hanger would prevent the straddle cable from catching in the tire and locking up the front wheel. The straddle cable length (when adjustable) is set to transfer as much force to the brake pads as possible. For the most efficient transfer of force, the straddle cable and the line between the cantilever pivot and the cable anchor should form a right angle (90 degrees). If the force is not at a right angle, part of the force gets wasted in pulling on the brake post, which has no effect on braking.

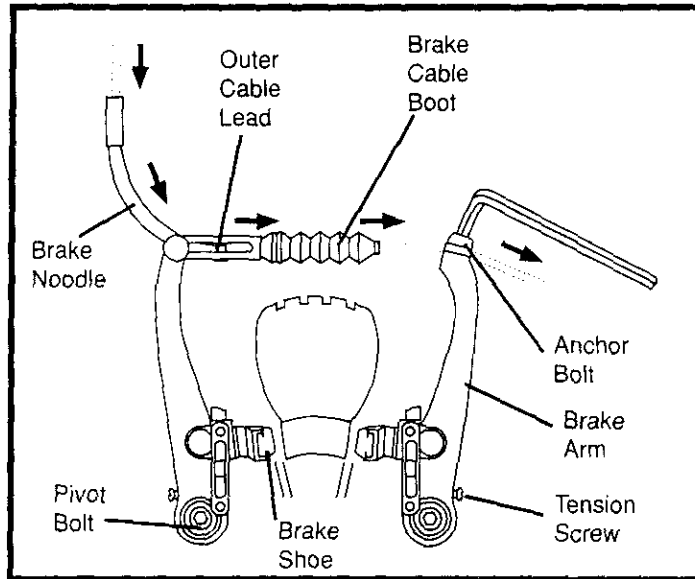

V-Style Brakes

Take the brake noodle from the parts box and slide the cable through the larger opening. The cable housing will then seat into the end of the noodle. Slide the cable through the cable lead on the end of the left brake arm, this will cause the noodle to fit into the lead. Slip the brake cable boot over the cable and position it between both brake arms. Next, loosen the 5mm anchor bolt at the end of the right brake arm and slide the cable under the retaining washer. Pull the slack out of the cable making sure a distance of 39mm or more remains between the end of the lead and the start of the anchor bolt. Once the cable is secured to the brake arms, engage the brake lever several times, checking the position of the brake shoes at the rim. The brake shoes should be 1mm away from the rim when in a relaxed position. When the brake lever is engaged, the brake shoe should hit the rim flush (never the tire) with the front touching slightly before the rear. If this position is not achieved, adjustments to the brake shoe are required. Loosen the brake shoe hardware and reposition the brake shoe. It may take several shoe and cable adjustments before the required position is accomplished.

V - Brake

1. If fitted with V-Brakes, insert the brake body into the center spring hole in the frame mounting boss, and then secure the brake body to the frame with the link fixing bolt.

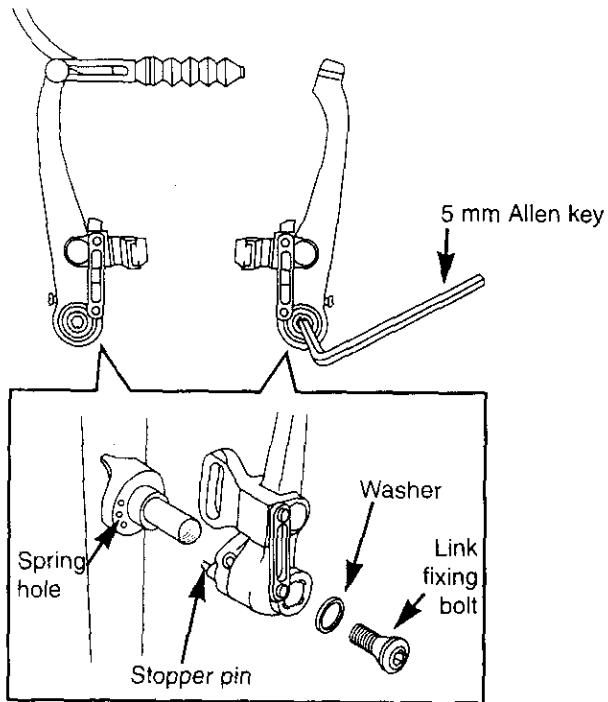

2. While holding the shoe against the rim, adjust the amount of shoe protrusion by interchanging the position of the B washers (i.e. 6 mm and 3 mm) so that dimension A is kept at 39 mm or more.

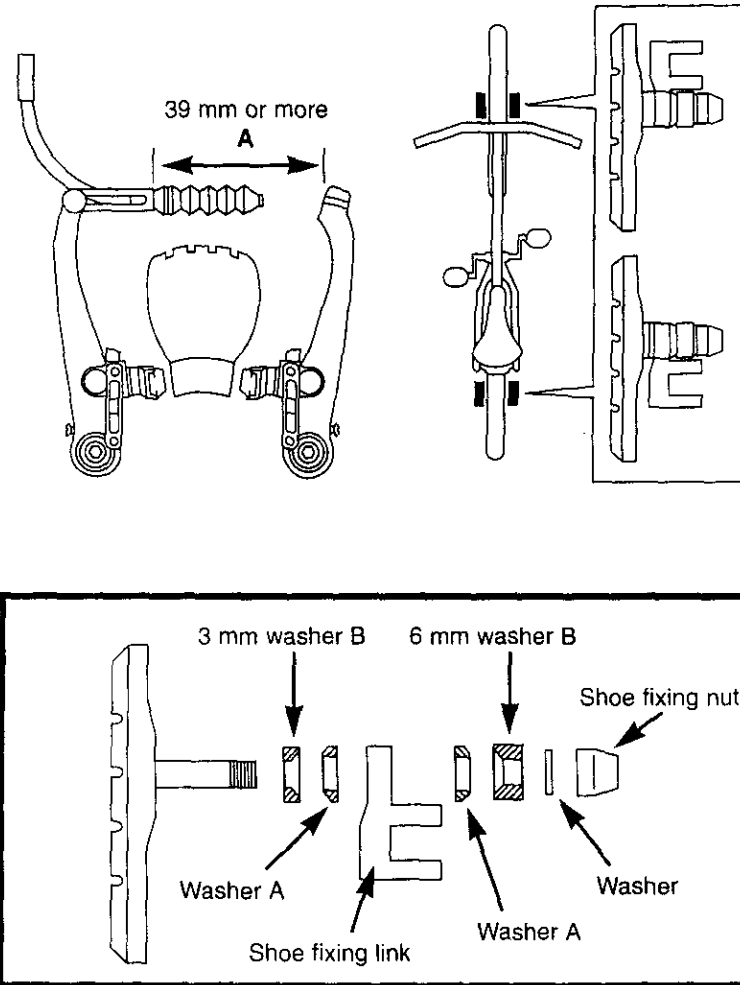



3. While holding the shoe against the rim, tighten the shoe fixing nut.

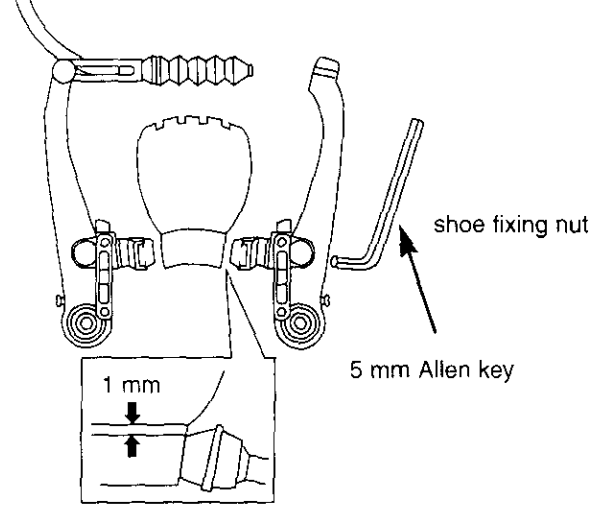

4. Pass the inner cable through the inner cable lead. Set the cable with a clearance of 1mm between each brake pad and the rim, tighten the cable fixing bolt.

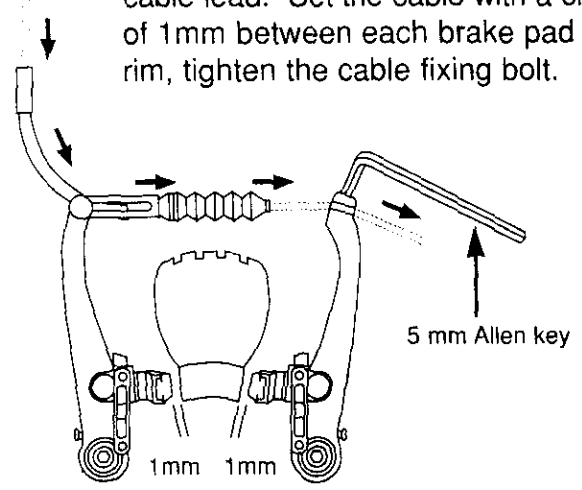

5. Adjust the balance with the spring tension adjustment screws.

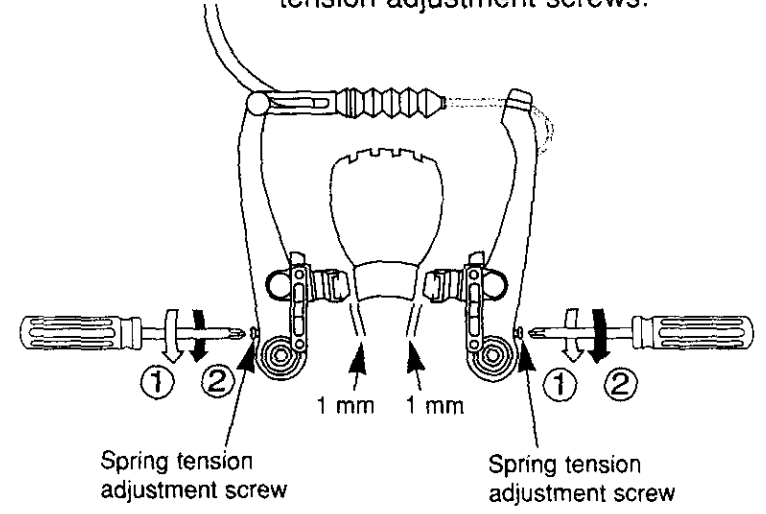

6. Depress the brake lever about 10 times as far as the grip to check that everything is operating correctly and that the shoe clearance is correct before using the brakes.

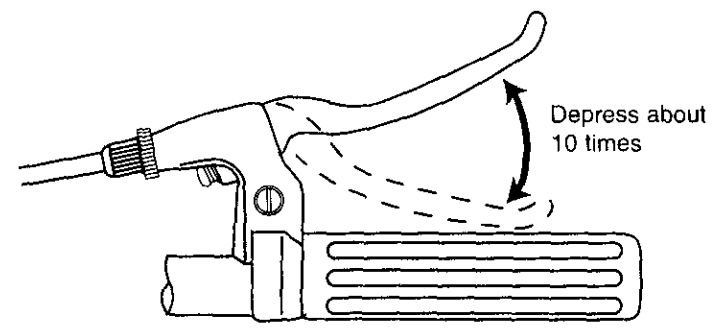



Check your Brakes

Press each brake lever to make sure that there is no binding and that the brake pads press hard enough on the rims to stop the bike. The brake pads should be adjusted so they are 1 mm to 2 mm away from the rim when the brakes are not applied. Brake pads should be centered on the rim and the rear portion of each brake pad should be about 0.5 - 1.0 mm farther from the rim than the front portion of the brake pad.

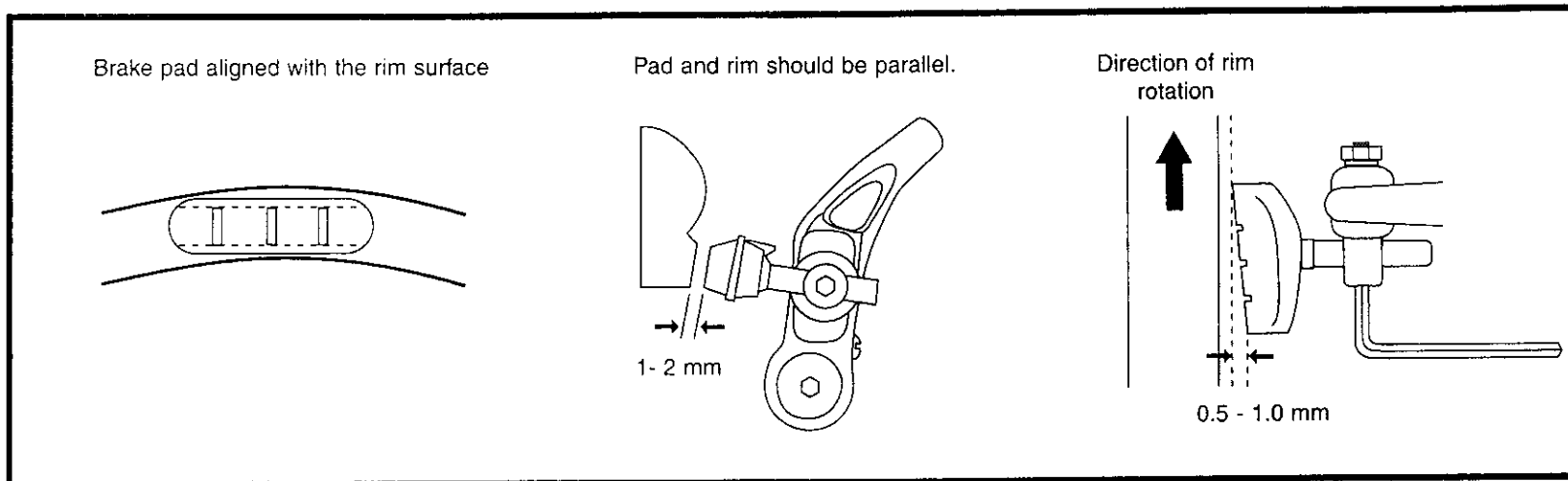

Do not ride the bicycle until the brakes are functioning properly. To test, apply the brakes while trying to push the bike forward to make sure they will stop the bicycle.

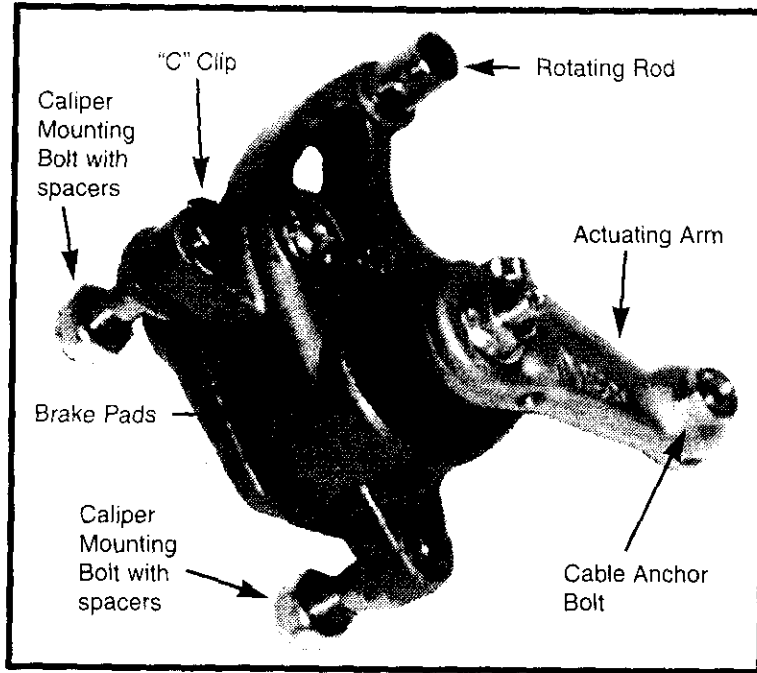
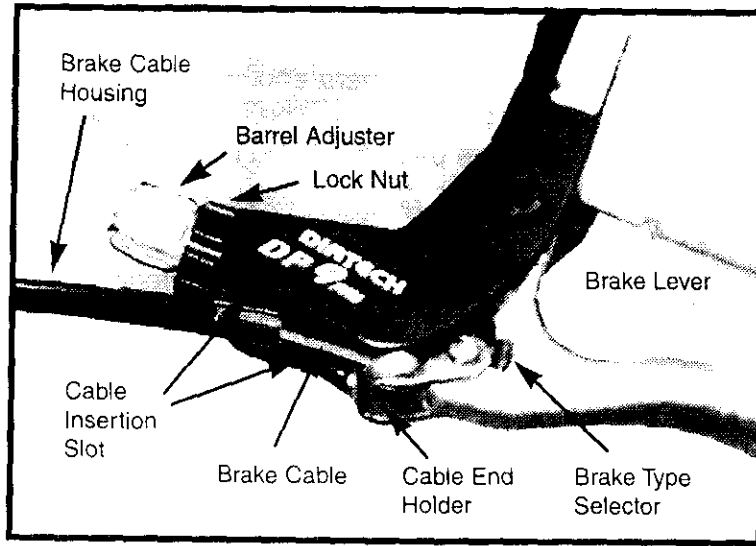

Disk Brakes

If fitted with a front disc brake, the components should already be attached. However, please check all connections before attempting to ride the bicycle. Secure tightly the 6 bolts that hold the disc to the front wheel hub and the 2 bolts that hold the brake mechanism to the fork. Insert the front rim into the fork dropouts ensuring that the disc fits into the brake mechanism between the enclosed brake pads. Secure the front rim to the bicycle by tightening the quick release mechanism and clamping the lever to the closed position. *Please refer to section 6 for further instruction on quick release mechanisms.*

Next, attach the cable to the brake lever by inserting the cable end into the cable end holder after the barrel adjuster and lock nut slots have been aligned with the cable end holder. After the cable is secured to the lever, rotate the barrel adjuster and lock nut so the slots no longer line up. Ensure the cable housing seats appropriately into the end of the barrel adjuster and check for any kinks or damage.

Slide the exposed brake cable through the rotating rod located on the caliper body and seat the housing into the same stop. Insert the cable into the spring and spring boot.

Next, slide the cable through the cable anchor and pull all the slack out. Secure the cable in place by tightening the bolts that comprise the anchor assembly. Some disc brakes will have a centering device while others are a free-floating mechanism. If your caliper body is equipped with centering bolts, apply the brake lever after the cable has been connected. While engaging the lever, tighten the centering bolts securely. This will center the caliper body on the disc.



DISC GETS HOT! Severe injury could result from contact with the hot disc! Mind your legs, as well as your hands.

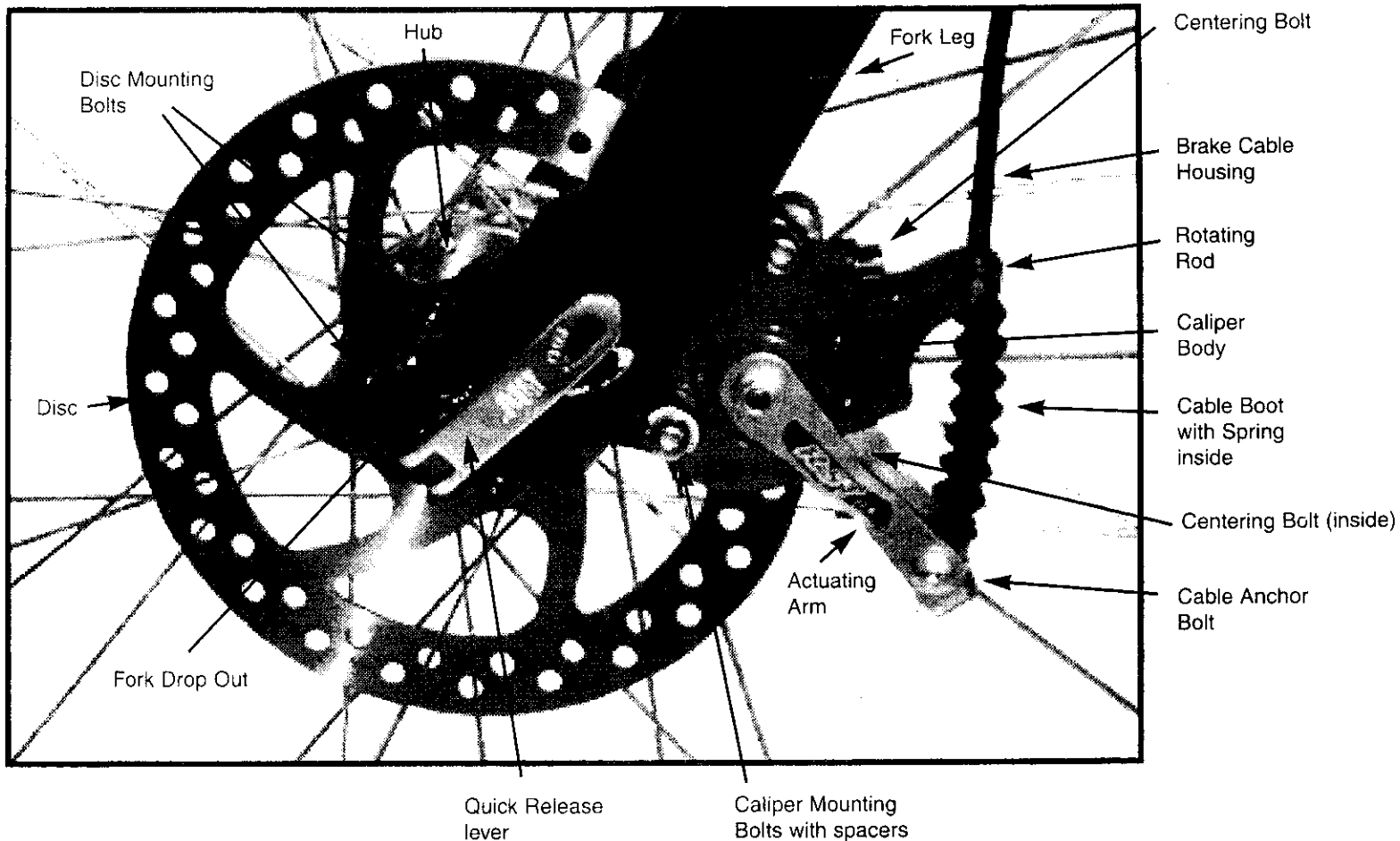

These brakes require breaking in! Ride and use the brakes gently for 13 miles before using the brakes in downhill conditions, for sudden stops, or any other serious braking. Please be aware that your brake system will change in performance throughout the wear-in process. The disc brake should be cleaned before the first ride using rubbing alcohol. NEVER use oil or similar products to clean your disc brake system.

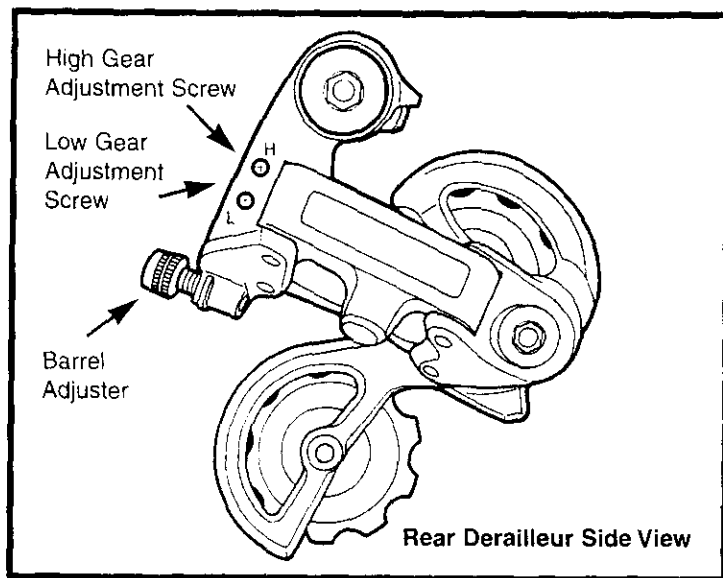
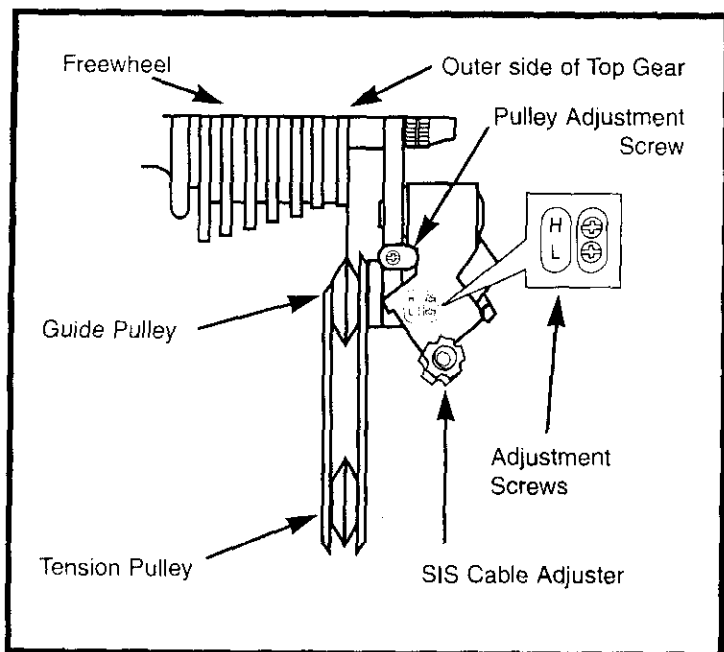

Derailleur

Although the front and rear derailleurs are initially adjusted at the factory, you will need to inspect and readjust both prior to riding the bicycle.

Rear Derailleur

Begin by shifting the rear shifter to largest number indicated, disconnect the cable from the rear derailleur cable anchor bolt, and place the chain on the smallest sprocket.

Adjust the **High** limit screw so the guide pulley and the smallest sprocket are lined up vertically. Reconnect the cable, pull out any slack, and retighten the anchor bolt securely. Shift through the gears, making sure each gear achieved is done quietly and without hesitation. If necessary, use the barrel adjuster to fine tune each gear by turning it the direction you want the chain to go. For example, turning clockwise will loosen the cable tension and move the chain away from the wheel, while turning counter-clockwise will tighten cable tension and direct the chain towards the wheel. Shift the rear shifter to the gear one and place the chain on the largest cog. Adjust the **Low** limit screw in quarter turn increments until the guide pulley and the largest cog are aligned vertically. Again, shift through each gear several times, checking that each gear is achieved smoothly. It may take several attempts before the rear derailleur and cable is adjusted properly.

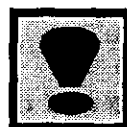

Ensure all bolts are secured tightly and the chain does not fall off in either direction.

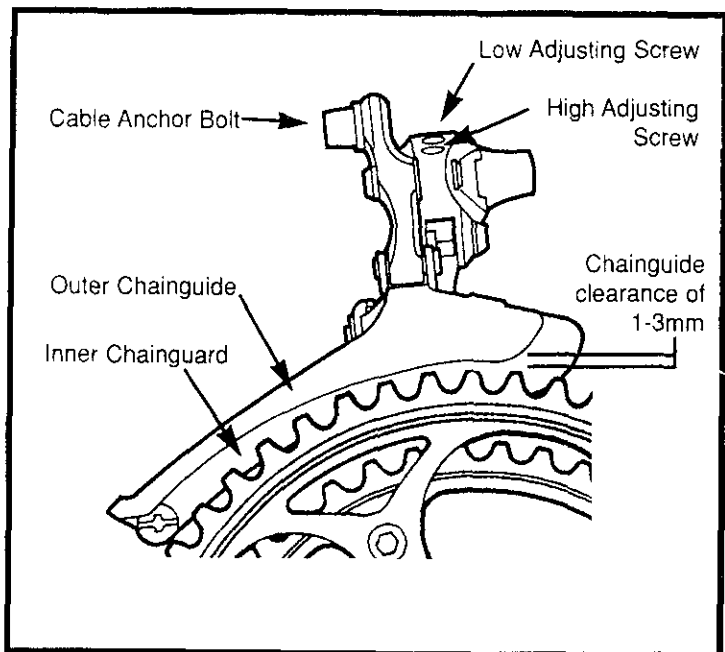

Front Derailleur

Shift both shifters to the smallest number indicated and place the chain on the corresponding cog and chainwheel. Disconnect the front derailleur cable from the cable anchor bolt. Check the position of the front derailleur; it should be parallel with the outer chainwheel and clear the largest chainwheel by 3-5mm when fully engaged.

With the chain on the smallest chainwheel in front and the largest cog in back, adjust the Low limit screw so the chain is centered in the front derailleur cage. Reconnect the cable, pull any slack out, and tighten the anchor bolt securely. Shift the front shifter to the largest chainwheel. If the chain does not go onto the largest chainwheel, turn the high limit screw in 1/4 turn increments counter-clockwise until the chain engages the largest chainwheel. If the chain falls off the largest chainwheel, and into the pedals, you will need to turn the High limit screw in 1/4 turn increments clockwise until the chain no longer falls off. Shift through every gear, using the barrel adjusters to fine tune each transition. The barrel adjuster for the front derailleur is located on the front shifter where the cable comes out of the shifter. Clockwise will loosen the cable tension and direct the chain closer to the frame while counter-clockwise will tighten the cable tension and direct the chain away from the frame.



Do not ride a bicycle that is not shifting properly. Overlooking proper adjustments may cause irreparable damage to the bicycle and/or bodily injury.

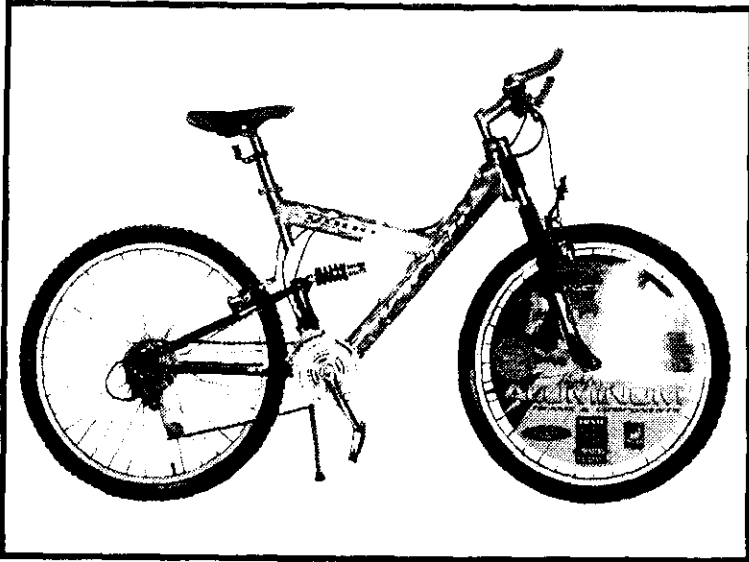

Dual Suspension

Dual Suspension bikes (DS) are equipped with a front fork as well as a rear suspension generally located below the seat. The piston works in conjunction with a spring to allow the bike to rotate on a pivot point. Ensure all attaching hardware is secured and there is no lateral movement of the rear triangle. The amount of Rear Suspension travel can be adjusted by turning the adjusting plate. Clockwise will increase spring tension and decrease travel, while turning counter-clockwise will decrease spring tension and increase travel.



There must be enough tension on the spring to hold the spring plate in place. Failure to do this may cause the mechanism to fail.

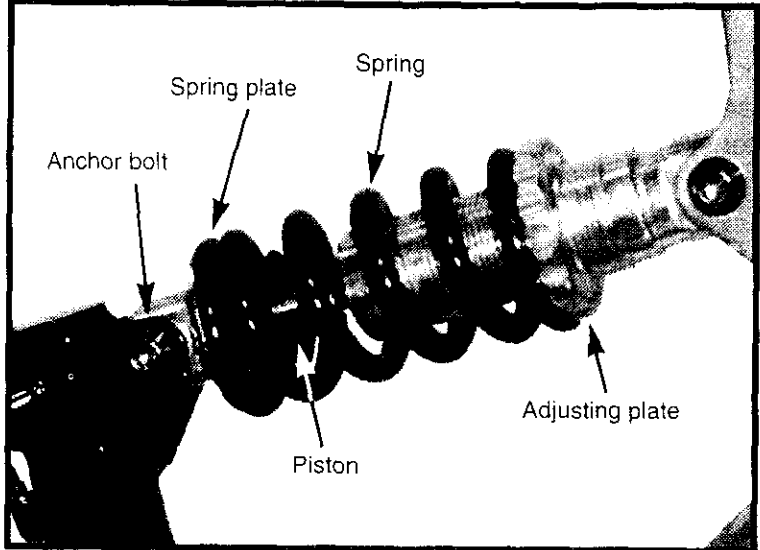

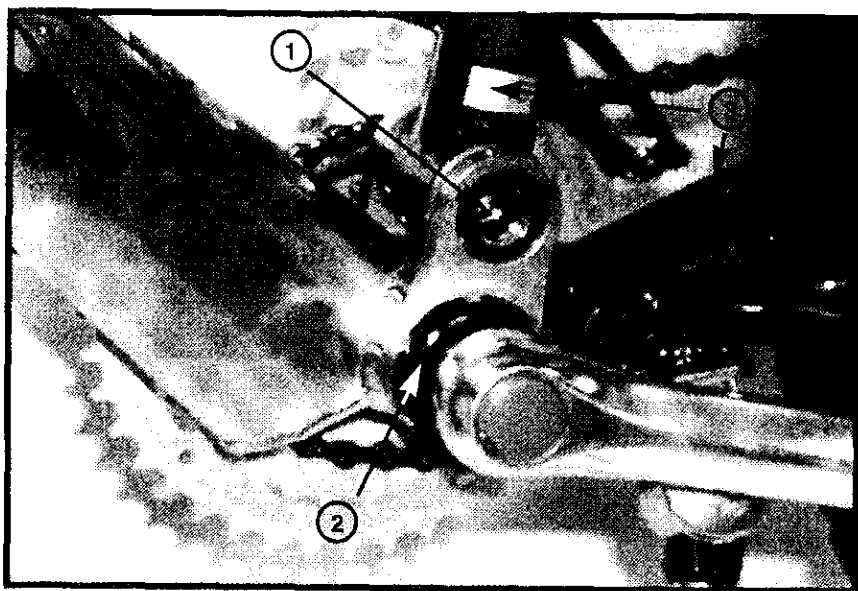
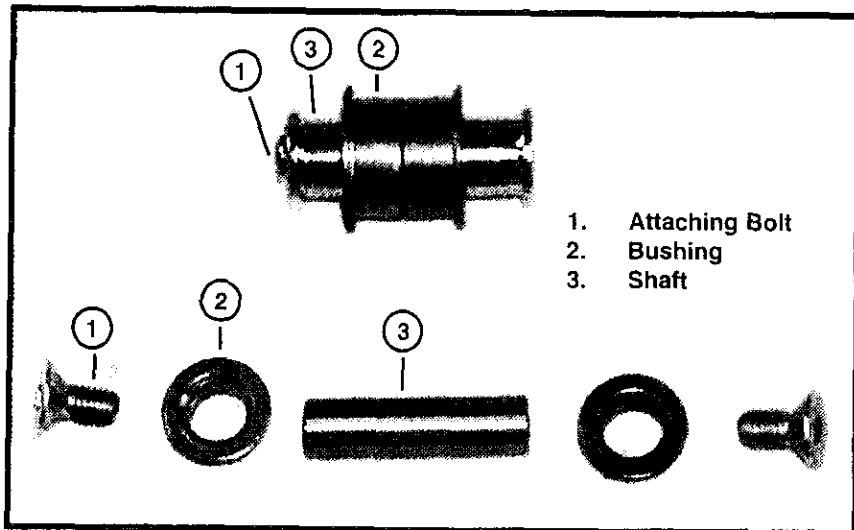

Rear Pivots

The pivot assembly is a simple mechanism that allows the rear triangle to move up and down in combination with a rear suspension. Size, shape, and compounds will vary between models; however, operating principles are the same. A shaft will pivot inside of two bushings secured in place with bolts. Pivots should be kept clean and free from grime and should be disassembled and re-greased at least once a riding season. Please note the drive side crank arm must be removed from the spindle before attempting to work on the pivot. Some models have two, small (2.5mm) Allen bolts on the underside of the bottom bracket shell. These must be removed before attempting to disassemble the pivot. After disassembling and cleaning, the shaft of the pivot assembly should be lightly coated with lithium-based grease, as well as the bushings and the threads of the attaching hardware. Please remember: Never use WD-40 to grease components. It is a degreaser that will not provide required lubrication and has a tendency to attract dust.



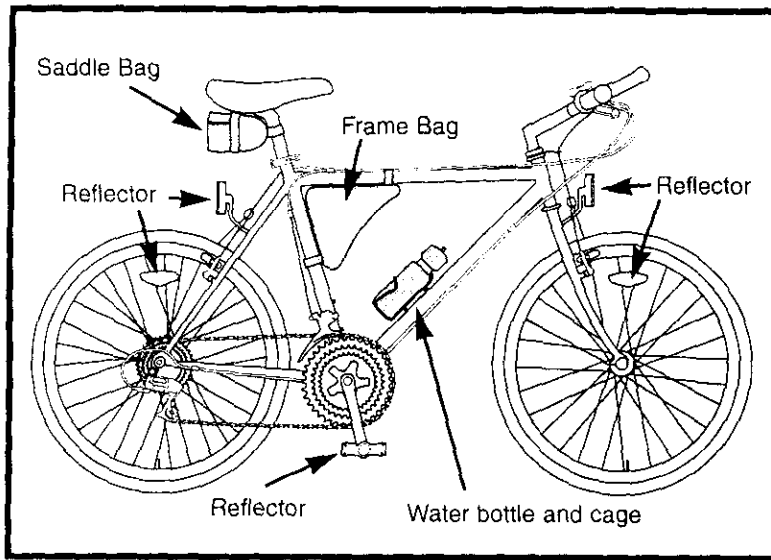

Tighten both rear wheel axle nuts or the quick release mechanism securely. Failure to do this may cause the rear wheel to dislodge from the frame dropouts resulting in serious damage or injury.

Accessories

If your bike is supplied with a water bottle and cage, attach the cage to the bicycle using the Allen bolts provided.

Most bikes come equipped with a saddle bag or frame bag. The saddle bag installs under the seat with the zipper facing the rear wheel. Undo the straps that wrap around the bag, thread them through the rails underneath the seat and secure around the bag. The smaller strap wraps around the seat post. Frame bags install at the apex of the top and seat tubes. Secure the straps around each tube.

NOTE: The frame bag straps must not bind the cables. The straps must go around the frame only.

Other: Some 20" and 24" model bicycles come with a rear derailleur guard to protect the rear derailleur from damage. To install, remove the the rear wheel axle nut on the drive side, install the rear derailleur guard over the axle with the U-shaped guard pointing down, and retighten the axle nut. The guard will sit between the frame and the axle nut.

Reflectors

Attach the white reflector to the front reflector bracket and secure to the fork using the hardware provided. Attach the red reflector to the rear reflector bracket and secure to the frame or seat post, depending on the bracket style, with the hardware provided.

Final Check

- After all adjustments have been made, shift through every gear several times at varying speeds. This will ensure all your adjustments are correct and will allow you to pinpoint any trouble areas. If you encounter any problems, refer to the appropriate section and make any necessary adjustments.
- Check the tire pressure and inflate each tube to the recommended psi as stated on the sidewall of the tire.
- Check that the kickstand operates smoothly and the kickstand bolt is secured tightly.
- Finally, examine the bicycle. Make sure all accessories are attached and all quick releases, nuts and bolts have been tightened securely.
- Correct maintenance of your bicycle will ensure many years of happy riding. Service your bicycle regularly by referring to the relevant sections of this manual, OR take it to a professional bicycle shop.

Remember: Always wear a helmet and obey all traffic laws.



Do not over-inflate the tires.





SINGLE SPEED & BMX

Includes 16" and 20" BMX Bikes
Assembly is the same for boy's and girl's bikes.

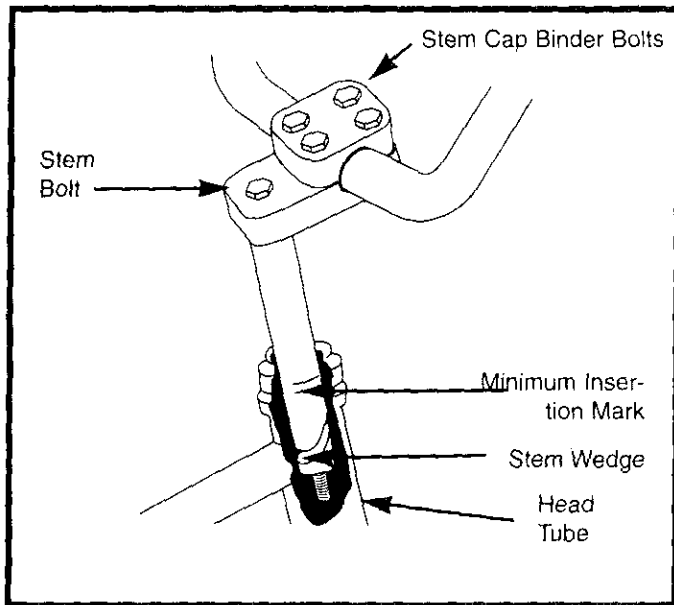
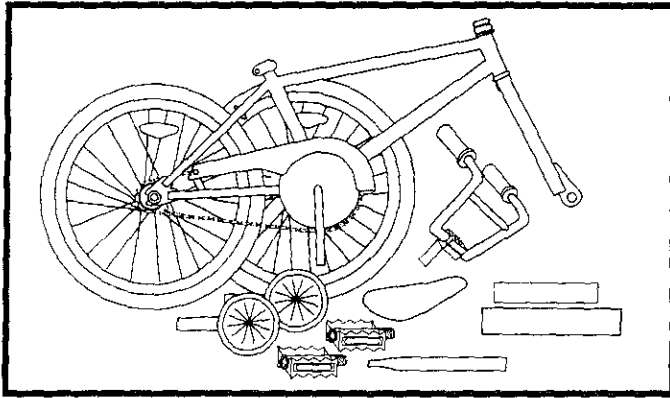

Foreword: Assembling a bicycle is an important responsibility. Proper assembly not only gives the rider more enjoyment of the bicycle; it also offers an important measure of safety.

Getting Started

Open the carton from the top and remove the bicycle. Remove the straps and protective wrapping from the bicycle. Inspect the bicycle and all accessories and parts for possible shortages. It is recommended that the threads and all moving parts in the parts package be lubricated prior to installation.

Do not discard packing materials until assembly is complete to insure that no required parts are accidentally discarded. Assemble your bicycle following the steps that pertain to your model.

Note: Your bicycle may be equipped with different style components than the ones illustrated.

Handlebars

Remove the protective cap from the stem wedge and loosen the stem bolt using the 6mm Allen key. Some models may use a 13mm hexagonal bolt instead of an Allen key bolt. Place the handlebar stem into the head tube, observing the minimum insertion mark on the handlebar stem and ensuring that all cables are free of tangles. Check that the fork and the handlebar are facing forward, and that they are properly aligned with the front wheel. Tighten the stem bolt. Rotate the handlebar to the desired position and tighten the Stem Cap Binder Bolts securely using a 5mm Allen key.



The handlebar must be inserted so that the minimum insertion mark cannot be seen.

Warning: Overtightening the stem bolt or headset assembly may cause damage to the bicycle and/or injury to the rider.

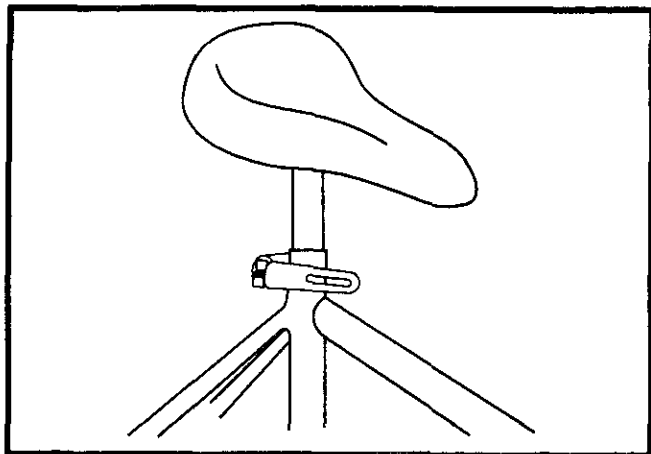

Seat

Loosen nut on the seat clamp and add 3 or 4 drops of oil onto the threads of the bolt. Place the smaller end of the seat post into the seat clamp until it stops with the bolt to the rear of the seat post. Thread the nut on the seat clamp loosely. Insert the larger end of the seat post into the seat tube of the bicycle frame observing the minimum insertion mark on the seat post. Position the top surface of the seat parallel with the ground. The serrations on the seat clamp must mesh completely with the seat frame serrations, push the front of the seat up and down to align the serrations. Securely tighten the seat clamp. Securely tighten the bolts on the seat post clamp. Turn the bicycle upside down and rest it on the seat and handlebars. If your bicycle is equipped with a quick release mechanism, please refer to page 24-25.



The seat pillar must be inserted so that the minimum insertion mark cannot be seen.

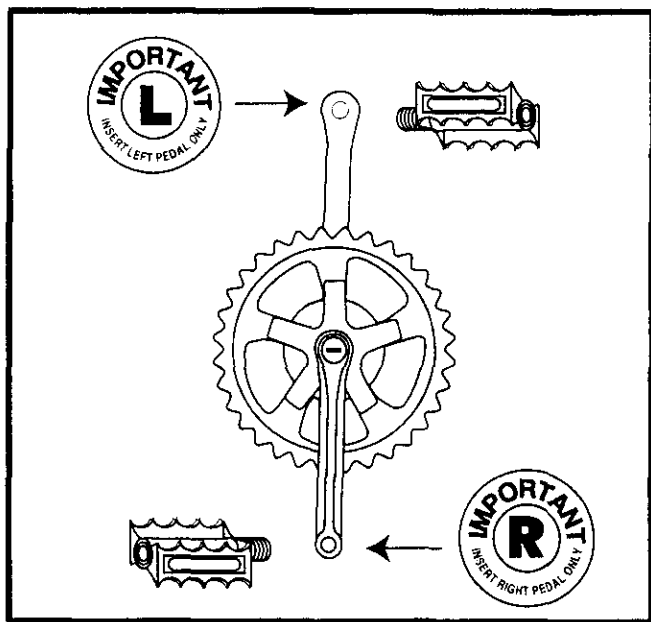

Pedals & Crank Set

Look for the letters "R" for right, and "L" for left, stamped on each pedal spindle. Start each pedal spindle by hand to avoid stripping the threads. Tighten with a 15mm narrow open ended wrench. Note that the right hand pedal attaches to the chainwheel side crank arm with a right-hand (clockwise) thread. The left pedal attaches to the other crank arm and has a left-hand (counter-clockwise) thread. It is very important that you check the crank set for correct adjustment and tightness before riding your bicycle. New cranks may become loose with initial use, refer to p. 74-77 for proper crank set adjustment and maintenance. Once the pedals have been attached, check that the crank arm rotates smoothly and that there is no lateral movement.



Attachment of an incorrect pedal into a crank arm will cause irreparable damage.

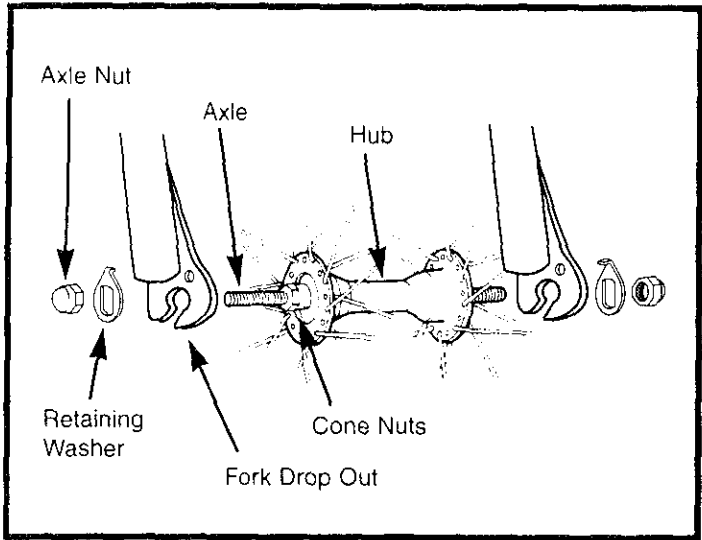
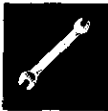

Front Wheel

1. Make sure the brakes are loose enough to allow the wheel to pass through the brake pads easily.
2. Place wheel into fork drop outs.
3. Install retaining washers with raised lip pointed towards the fork, and insert into the small hole of the fork blade.
4. Install axle nut and tighten. Make sure the wheel is centered between the fork blades.
5. Spin the wheel to make sure that it is centered and clears the brake shoes. Tighten the brakes if necessary.
6. Turn the bicycle upright using the kickstand to support it.



It is very important to check the front wheel connection to the bicycle. Failure to properly tighten may cause the front wheel to dislodge.

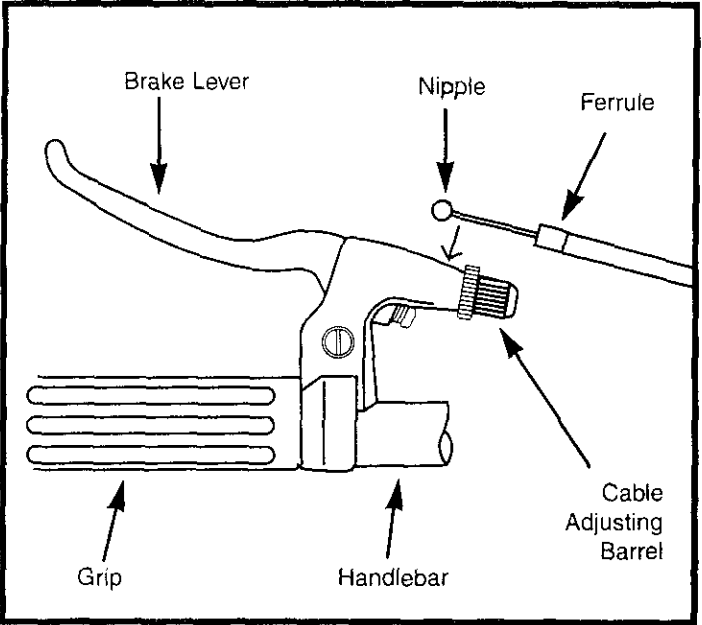

Front Brake

Determine which type of brake your bike is equipped with and refer to the appropriate assembly instructions. For more information on brake adjustment and maintenance, refer to p. 68-71. A greater force is required to activate the rear brake due to longer cable length. It is advisable to mount the rear brake on the side of the stronger hand. It is important to become familiar with the use of hand brakes. When properly adjusted, hand brakes are an efficient braking system. Keep the rim and brake shoes clean and free from wax, lubricants and dirt at all times. **Keep brakes properly adjusted and in good working condition at all times.**

Open the brake lever and place the nipple end of the short brake cable into the lever, then close the lever. Secure the ferrule against the lever using the cable adjusting barrel.

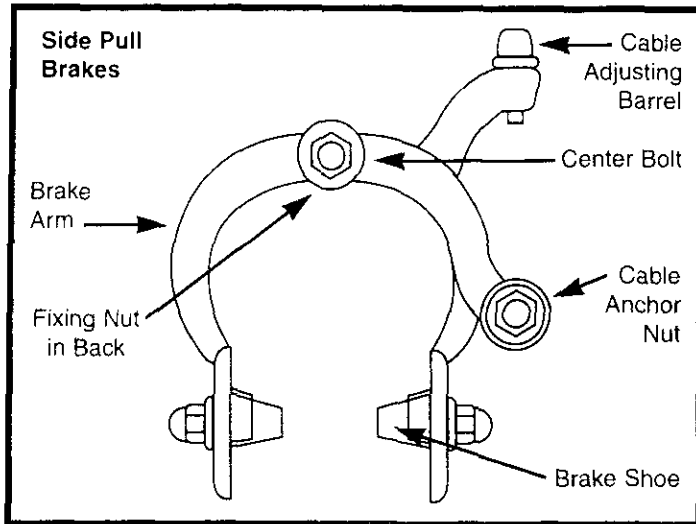

Side Pull Brake

Loosen the cable anchor nut and thread the brake cable through it. Tighten the nut by hand until it holds the cable in place. Squeeze the brake arms together against the rim of the wheel. Loosen the nuts on the brake shoes and turn until they match the angle of the rim. Tighten the nuts securely. Pull down on the end of the brake cable with pliers, hold taut and securely tighten the cable anchor nut. Spin the wheel, the brake shoes should not contact the rim at any point and should be an equal distance from the rim on both sides. Make sure all nuts and bolts are securely tightened. Test the brake levers 20-25 times to take care of any initial cable stretch. Be sure to tightly secure the brake fixing nut behind the fork.

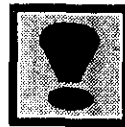
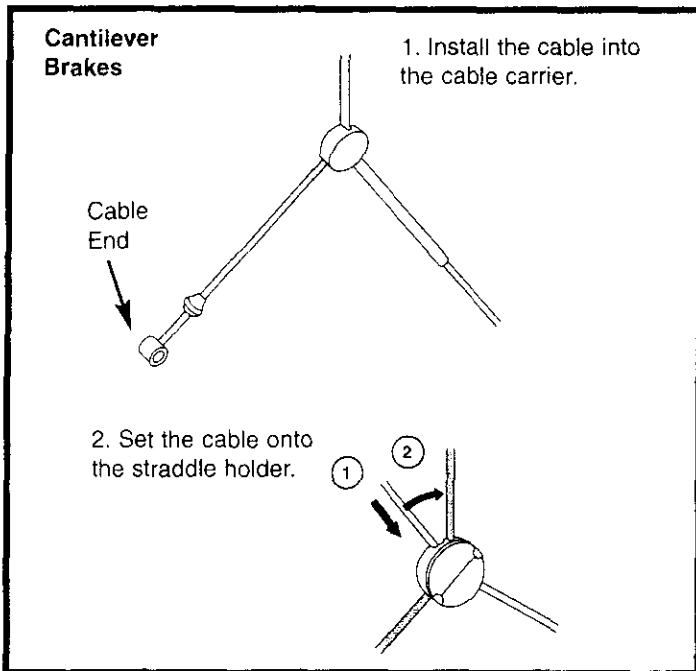

When assembling or adjusting the brakes, make sure the cable anchor is tight. Failure to securely tighten the nut could result in brake failure and personal injury.

Cantilever Brakes - Utilizing a Link Wire

If fitted with cantilever type brakes, insert the brake cable into the link wire lead, and notch the cable end into the slot of the left brake arm. Loosen the anchor bolt on the right brake arm and slide the brake cable under the tabbed washer. Squeeze both brake arms together so the brake shoes hit the rim, pull all slack out of the brake cable, and tighten the anchor bolt. With the cable fitted, the straddle holder should sit 10-20mm above the reflector bracket. Adjust the brake shoes using a 10mm wrench so that they are parallel with the rim and are positioned 1-2mm away from the rim. Several adjustments may be necessary to achieve the correct brake position.



3. Temporarily tighten the cable so that the link wire is at the position in the illustration.

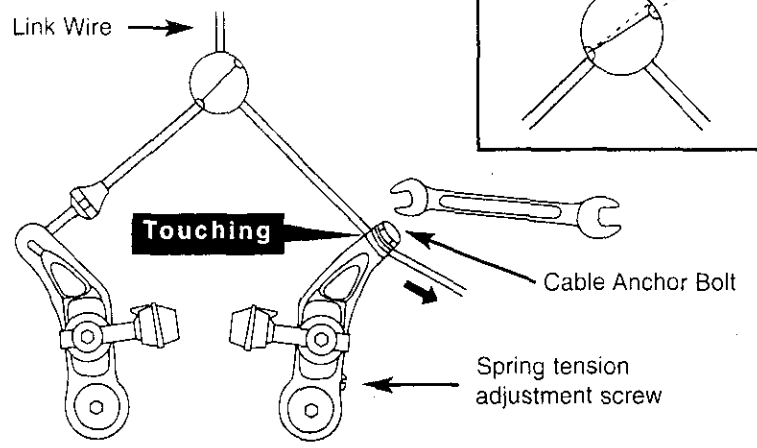

4. Turn the spring tension adjustment screw so that the link wire comes to a position directly below the cable casing holder.

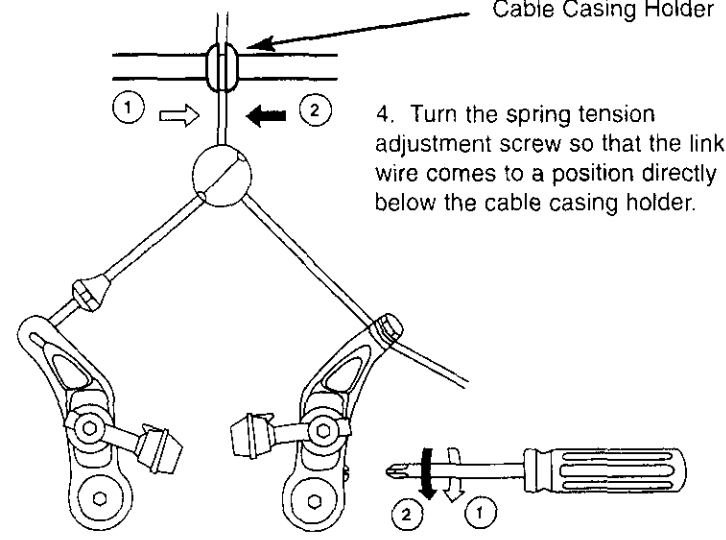

5. Secure one of the shoes at a time. The adjustment of the shoe clearance is not necessary at this time. Shoe fixing nut tightening torque: 7.84 - 8.82 Nm (70 - 78 in. lbs.)

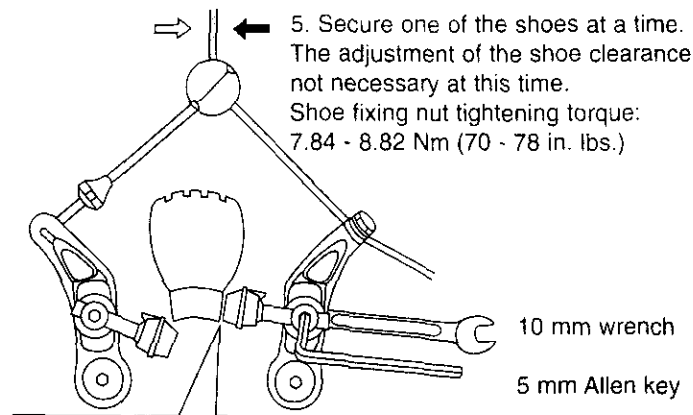

6. If balance adjustment is necessary, adjust with the spring tension adjustment screw.

Cut off any unnecessary cable, attach an end cap, and hook it onto the notched part of the nut which secures the shoe.

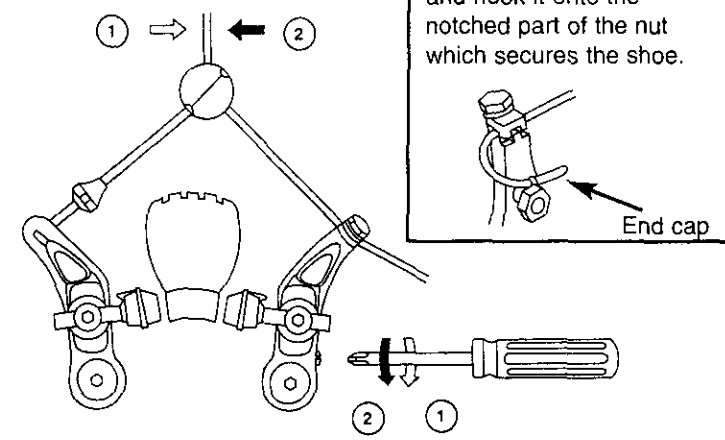

V - Brake

1. If fitted with V-Brakes, insert the brake body into the center spring hole in the frame mounting boss, and then secure the brake body to the frame with the link fixing bolt.

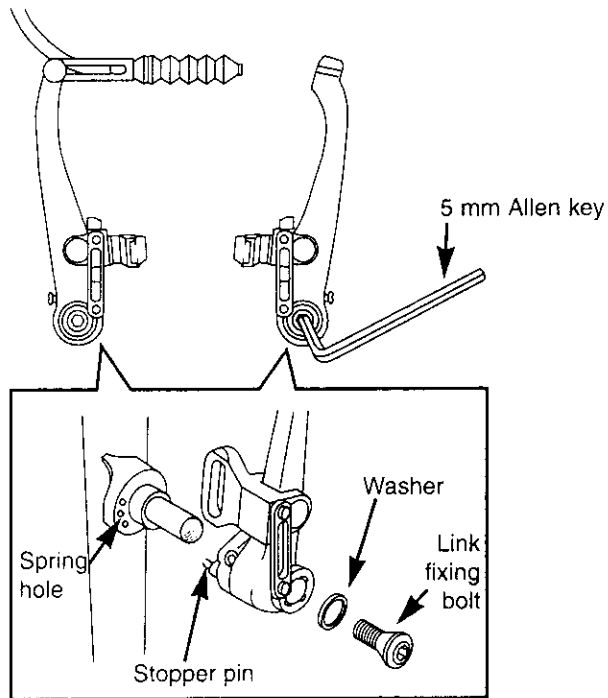

2. While holding the shoe against the rim, adjust the amount of shoe protrusion by interchanging the position of the B washers (i.e. 6 mm or 3 mm) so that dimension A is kept at 39 mm or more.

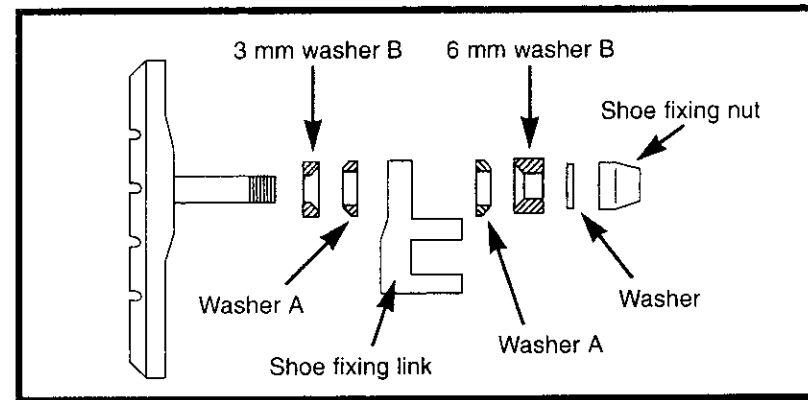
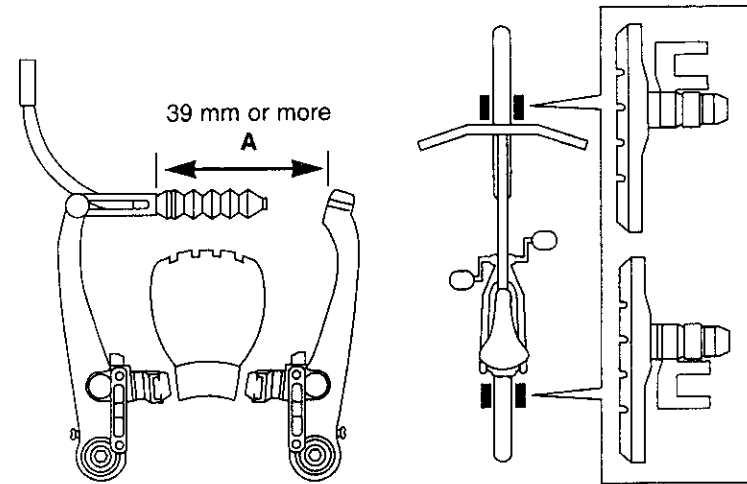



3. While holding the shoe against the rim, tighten the shoe fixing nut.

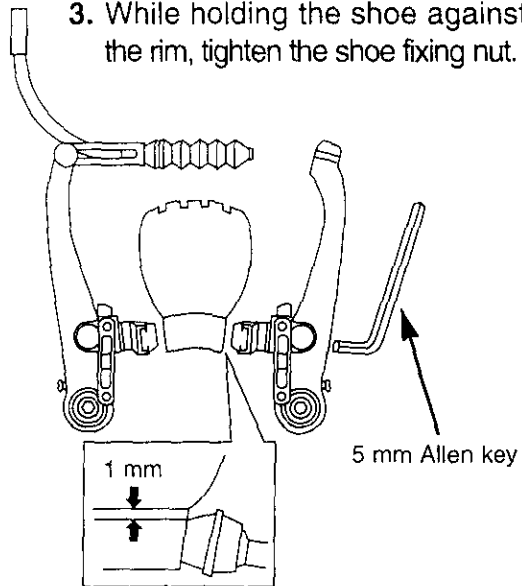

4. Pass the inner cable through the inner cable lead. Set the cable with a clearance of 1 mm between each brake pad and the rim, tighten the cable fixing bolt.

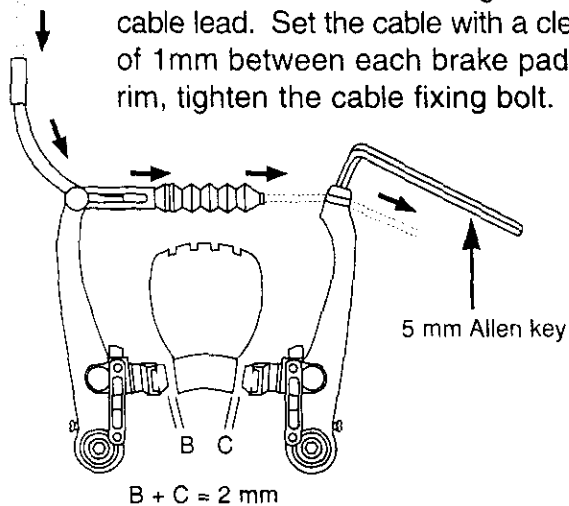

5. Adjust the balance with the spring tension adjustment screws.

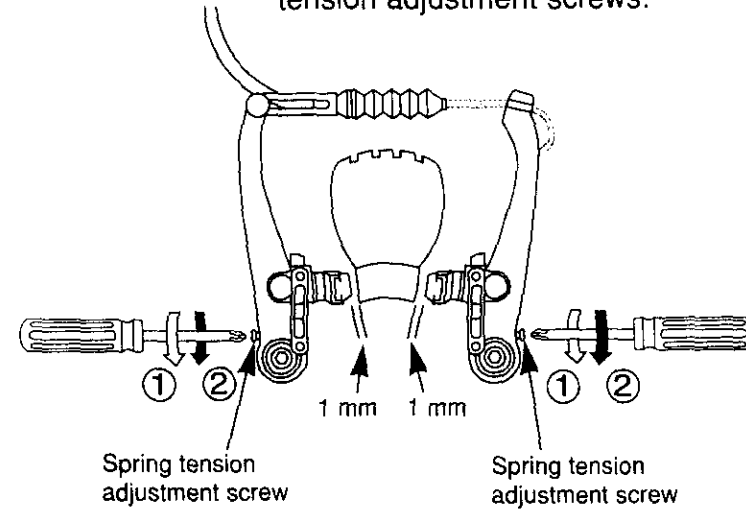

6. Depress the brake lever about 10 times as far as the grip and check that everything is operating correctly and that the shoe clearance is correct before using the brakes.

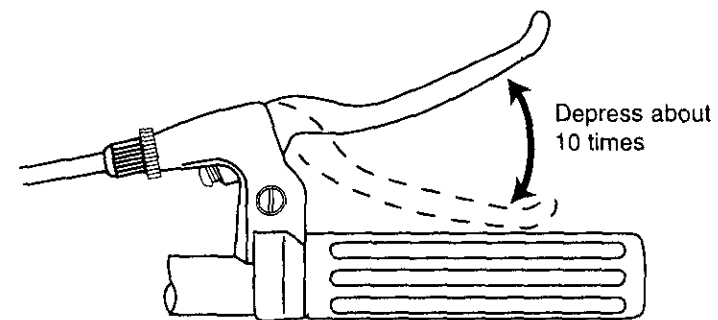

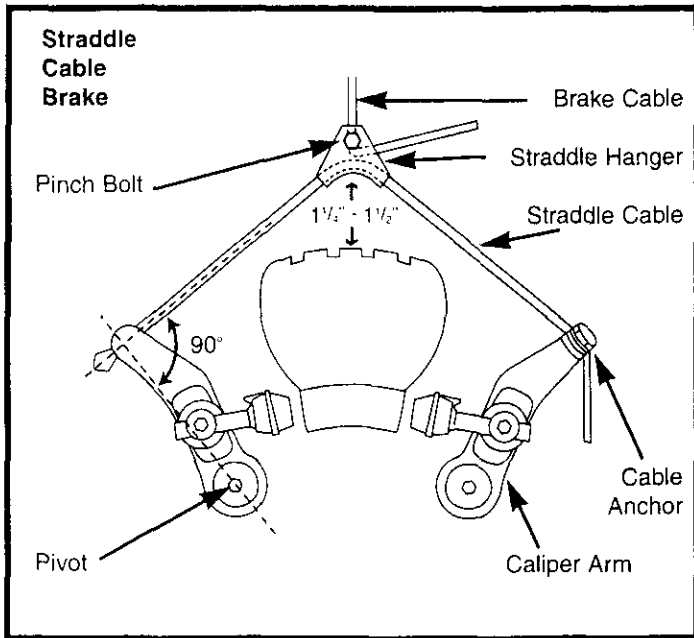

Cantilever Brakes - Utilizing a Straddle Cable

The length of the straddle cable, the height of the straddle hanger, and the brake pad-to-caliper arm position all have an effect on braking power. Generally, the straddle cable bridge is set low and close to the tire for maximum braking force. The straddle cable should be high enough, however, to adequately clear the tire (and any debris that may stick to the tire) or to fit over the front reflector hanger. In the event of brake cable failure, the front reflector hanger would prevent the straddle cable from catching in the tire and locking up the front wheel. The straddle cable length (when adjustable) is set to transfer as much force to the brake pads as possible. For the most efficient transfer of force, the straddle cable and the line between the cantilever pivot and the cable anchor should form a right angle (90 degrees). If the force is not at a right angle, part of the force gets wasted in pulling on the brake post, which has no effect on braking.

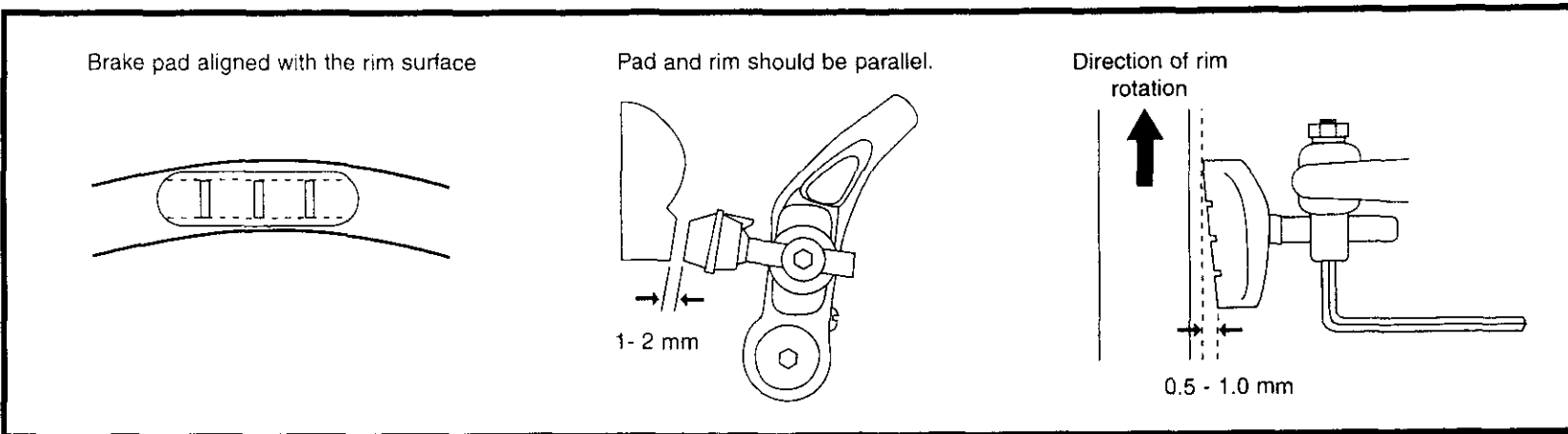



Check your Brakes

Press each brake lever to make sure that there is no binding and that the brake pads press hard enough on the rims to stop the bike. The brake pads should be adjusted so they are 1mm to 2 mm away from the rim when the brakes are not applied. Brake pads should be centered on the rim and the rear portion of each brake pad should be about 0.5 - 1.0 mm farther from the rim than the front portion of the brake pad.



Do not ride the bicycle until the brakes are functioning properly. To test, apply the brakes while trying to push the bike forward to make sure they will stop the bicycle.

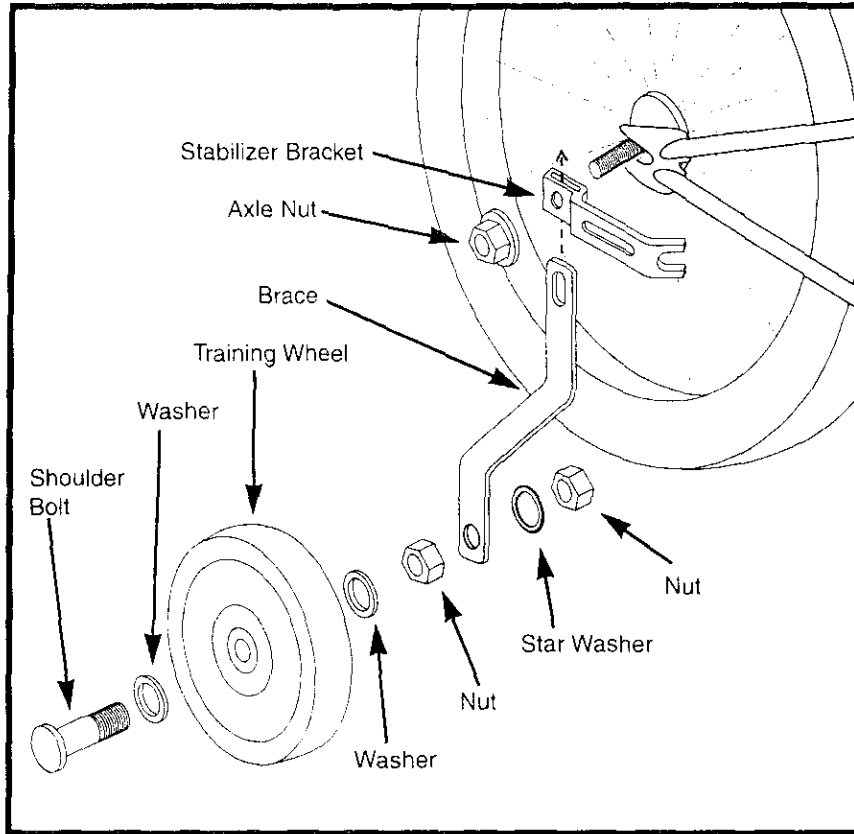

Training Wheels

1. Position a washer on the shoulder bolt. Insert the shoulder bolt through the wheel. Follow with another flat washer then completely thread a nut on the shoulder bolt.
2. Insert the shoulder bolt through the brace. Set the "star" washer on the shoulder bolt. Lock into place by screwing another nut onto the shoulder bolt.
3. Remove the nut and washer from the rear wheel axle. Align stabilizer bracket onto the brace. Align brace and stabilizer bracket on the wheel axle. Replace the axle nut and washer, secure tightly. The elongated hole on the brace allows for raising or lowering the training wheel to the proper height.

Rotors

Some freestyle BMX bicycles come equipped with a detangler system that will allow the handlebar to spin 360-degrees without binding the cables. It is very important that this system is adjusted correctly. Installation should only be done by a qualified bicycle mechanic with the correct tools.

Upper Cable

1. First connect the barrel end of the upper cable to the rear brake lever. Make sure the long cable casing is on top of the short cable casing; otherwise, the upper cable will have a twist in it.
2. Route the upper cable through the handlebars (below the crossbar) with the short cable casing on the same side as the rear brake lever.
3. Connect the upper cable to the upper plate by passing the football ends of the upper cable through the threaded holes in the upper plate and connecting them to the bearing.
4. Screw the adjusting barrels into the upper plate. Don't tighten the locknuts at this time.

Lower Cable

1. Slide the cable casing through the cable guide on the frame.
2. Connect the lower cable to the lower plate by passing the football ends of the lower cable through the threaded holes in the lower plate and connecting them to the bearing.
3. Screw the adjusting barrels into the lower plate. Don't tighten the locknuts at this time.
4. Connect the lower cable to the rear brake. Don't adjust the rear brake at this time.

NOTE: Check to make sure all 11 cable casing ends on the upper and lower cables are seated correctly, and that the spring tension of the rear brake is pulling the bearing down.

Adjustment

1. Screw the cable adjusters on the rear brake lever and the upper cable splitter all the way in.
2. Screw the adjusting barrels in the upper plate in (or out)

to set the bearing for maximum travel. The bearing should be as far down as it can go without resting on the lower plate or the adjusting barrels screwed into the lower plate.

3. Use the adjusting barrels that are screwed into the upper plate to make the bearing parallel to the upper plate. Use a 10mm wrench to tighten the locknut on the left adjusting barrel of the upper cable. Leave the right adjusting barrel loose.
4. Screw the lower cable adjusting barrel into (or out of) the lower plate until they are as close to the bearing as they can get without touching it.
5. Screw the cable adjuster on the upper cable splitter out until all slack is removed from the upper cable. Then screw the cable adjuster out one more turn to raise the bearing an additional 1mm away from the lower cable adjusting barrels.
CAUTION: Don't screw the cable adjuster on the upper cable splitter out more than 8mm. Use the cable adjuster on the rear brake lever if more adjustment is needed.
6. Check for bearing flop by placing the handlebars in the normal riding position, then quickly rotate the handlebars back and forth. Perform the following steps to eliminate bearing flop.
NOTE: The bearing should never be allowed to rest on the lower plate or lower cable adjusting barrels.
 - a) Screw the lower cable adjusting barrels out of (or into) the lower plate until all bearing flop is eliminated.
 - b) Tighten the locknut of the right adjusting barrel on the lower cable.
 - c) Rotate the handlebars 180 degrees and recheck for bearing flop. If there is any bearing flop, use the "loose" adjusting barrels on the upper and lower cable to remove it.
 - d) Repeat steps (6a) and (6c) until the handlebars can be rotated 360 degrees without any bearing flop.
7. Finish adjusting the rear brakes.





Failure to adjust correctly may result in loss of braking power and personal injury.

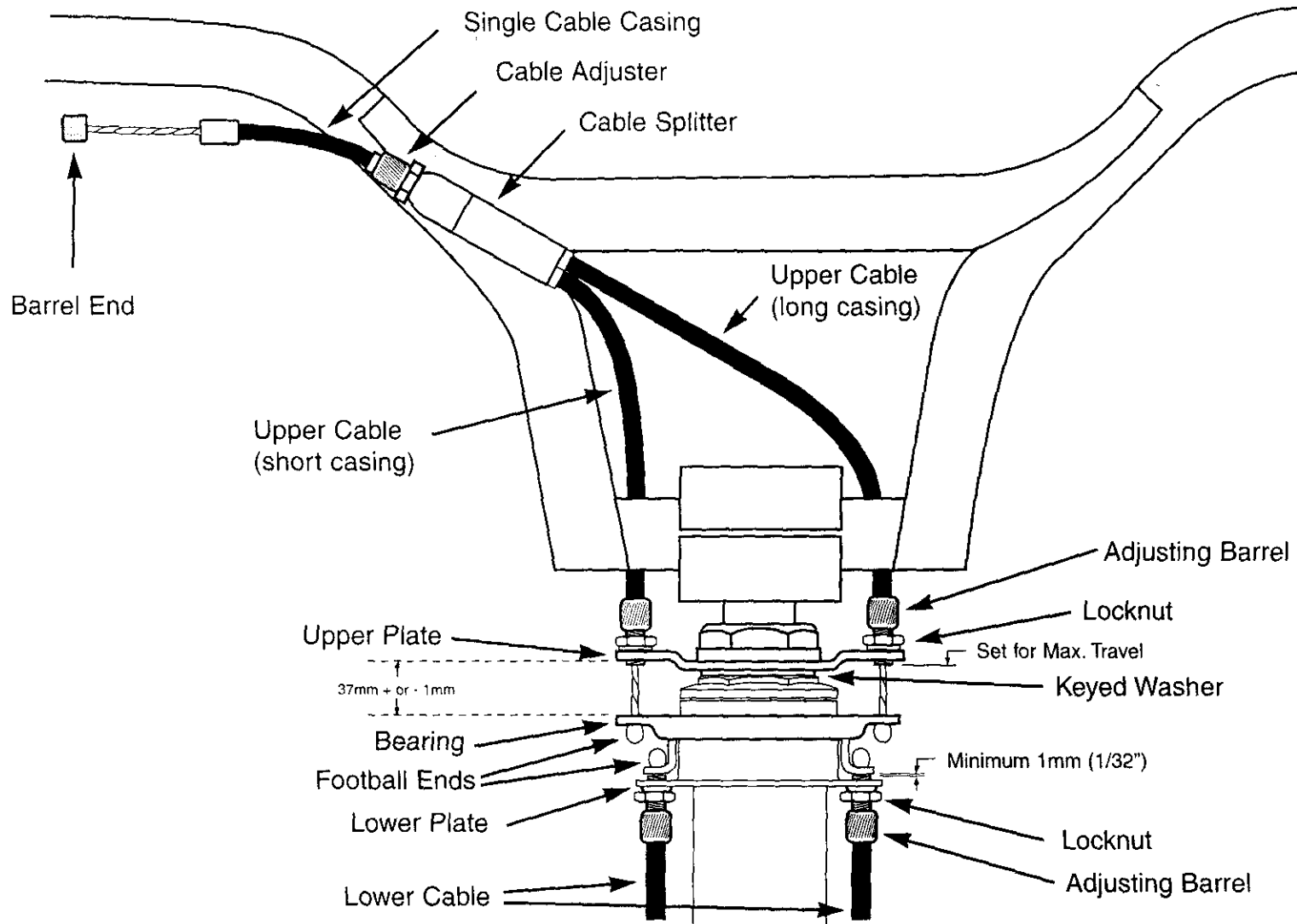

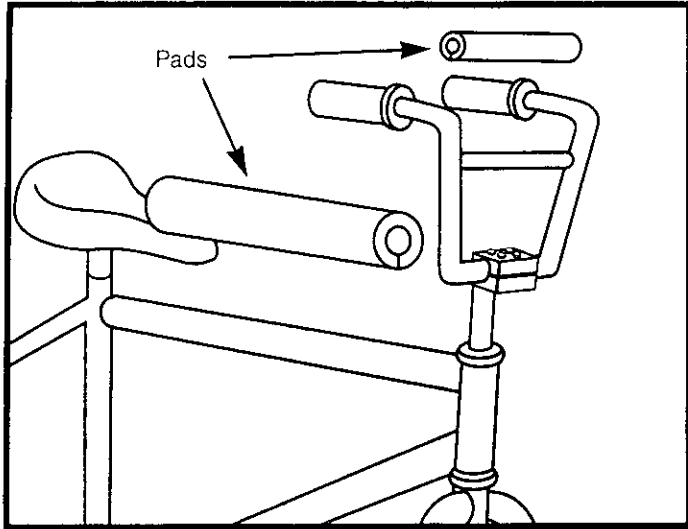

Final Check

Install any additional parts that are supplied with your bike.

NOTE: Your bicycle may be equipped with different style components than the ones illustrated.

Reflectors: Attach the white reflector to the front bracket and the red reflector to the rear bracket using an 8mm wrench or a Phillips head screwdriver. Attach the brackets to the bicycle using the hardware provided. For some models, the front reflector bracket will be mounted on the front brake assembly bolt that fits through the fork. It is important to make sure all connections are tightened securely and that the reflectors are properly angled.

Pads: If your bike is supplied with pads, wrap the foam inner cushion around the appropriate bar. Place the outer cover over the inner cushion and press the velcro together securely. Turn the pad so the velcro faces the ground.

Chainguards: If not already attached, attach the chainguard to the bicycle frame using the clamps provided. Secure in place making sure the guard does not bind or get caught on the chain.

Tire Pressure: Check tire pressure, inflate to the range recommended on the tire sidewalls.

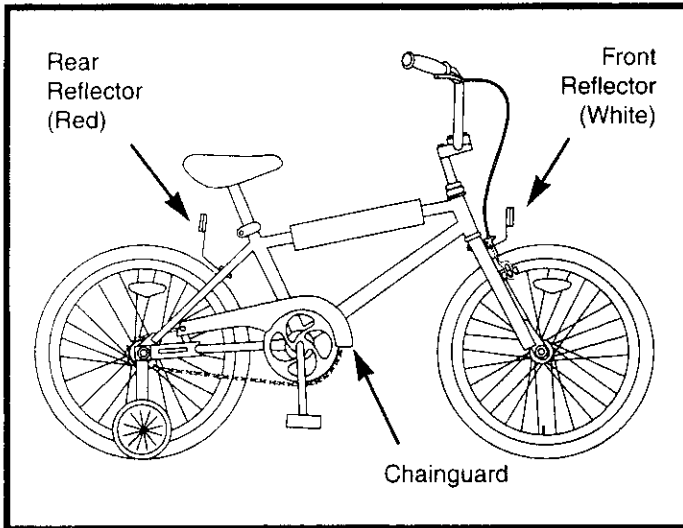

Before riding, ensure all nuts, bolts and fittings on the bicycle have been correctly tightened.



Correct routine maintenance of your new bike will ensure:

Smooth running - Longer lasting components - Safer riding - Lower running costs

Every time you ride your bicycle, its condition changes. The more you ride, the more frequently maintenance will be required. We recommend you spend a little time on regular maintenance tasks. The following schedules are a useful guide and by referring to Part 5 of this manual, you should be able to accomplish most tasks. If you require assistance, we recommend you see a bicycle specialist.

Schedule 1 - Lubrication

Frequency	Component	Lubricant	How to Lubricate
Weekly	chain	chain lube or light oil	brush on or squirt
	derailleur wheels	chain lube or light oil	brush on or squirt
	derailleurs	oil	oil can
	brake calipers	oil	3 drops from oil can
	brake levers	oil	2 drops from oil can
Monthly	shift levers	lithium based grease	disassemble
Every Six Months	freewheel	oil	2 squirts from oil can
	brake cables	lithium based grease	disassemble
Yearly	bottom bracket	lithium based grease	disassemble
	pedals	lithium based grease	disassemble
	derailleur cables	lithium based grease	disassemble
	wheel bearings	lithium based grease	disassemble
	headset	lithium based grease	disassemble
	seat pillar	lithium based grease	disassemble

Note: The frequency of maintenance should increase with lots of usage and use in wet or dusty conditions. Do not over lubricate - remove excess lubricant to prevent dirt build up. Never use a degreaser to lubricate your chain (WD-40)

Schedule 2 - Service Checklist



Frequency	Task	Page Reference
Before every ride	Check tire pressure	55
	Check brake operation	66-69
	Check wheels for loose spokes	54
	Make sure nothing is loose	54
After every ride	Quick wipe down with damp cloth	16-17
Weekly	Lubrication as per schedule 1	51
Monthly	Lubrication as per schedule 1	51
	Check derailleur adjustment	79-81
	Check brake adjustment	66-69
	Check brake and gear cable adjustment	61,66
	Check tire wear and pressure	55
	Check wheels are true and spokes tight	54
	Check hub, head set and crank bearings for looseness	56,62,73
	Check pedals are tight	70
	Check handlebars are tight	58-59
	Check seat and seat post are tight and comfortably adjusted	64
Check frame and fork for trueness	63	
Every Six Months	Check all nuts and bolts are tight	
	Lubrication as per schedule 1	51
	Check all points as per monthly service	52
	Check and replace brake pads, if required	69
Yearly	Check chain for excess play or wear	76
	Lubrication as per schedule 1	51



Tools Required

1. Open ended wrench or ring wrenches: 8mm, 9mm, 10mm, 12mm, 13mm, 14mm, 15mm
2. Open end or pedal wrench 15mm
3. Allen key wrenches: 4mm, 5mm, 6mm, 8mm
4. Adjustable wrench
5. Standard flat head screwdriver
6. Standard Phillips head screwdriver
7. Standard slip joint pliers
8. Tire pump
9. Tube repair kit
10. Tire levers

Travel Tools

1. Spare Tube
2. Patch kit
3. Pump
4. Tire levers
5. Multi-tool
6. Change (phone call)

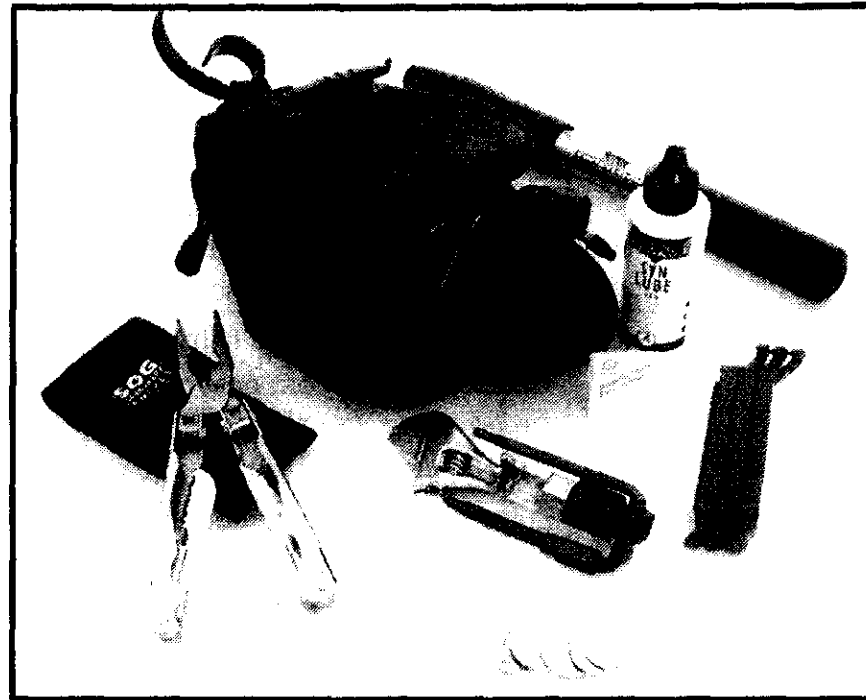
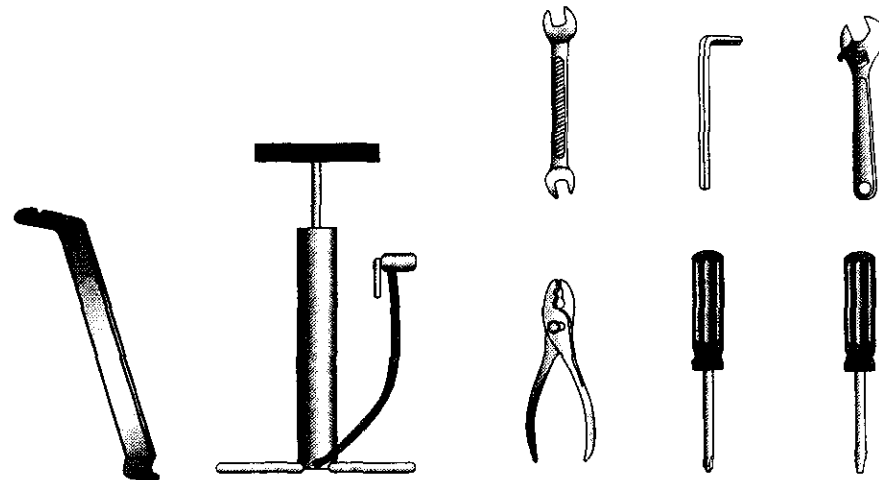

WHEELS AND TIRES

Wheel Inspection

It is most important that wheels are kept in top condition. Properly maintaining your bicycle's wheels will help braking performance and stability when riding. Be aware of the following potential problems:

- Dirty or greasy rims:

Caution: These can render your brakes ineffective. Do not clean them with oily or greasy materials. When cleaning, use a clean rag or wash with soapy water, rinse and air dry. Don't ride while they're wet.

When lubricating your bicycle, don't get oil on the rim braking surfaces.

- Wheels not straight:

Lift each wheel off the ground and spin them to see if they are crooked or out of round. If wheels are not straight, they will need to be adjusted. This is quite difficult and is best left to a bicycle specialist.

- Broken or loose spokes:

Check that all spokes are tight and that none are missing or damaged.

Caution: Such damage can result in severe instability and possibly an accident if not corrected.

Again, spoke repairs are best handled by a specialist.

- Loose hub bearings:

Lift each wheel off the ground and try to move the wheel from side to side.

Caution: If there is movement between the axle and the hub, do not ride the bicycle. Adjustment is required.

- Axle nuts:

Check that these are tight before each ride.

- Quick release:

Check that these are set to the closed position and are properly tensioned before each ride.

Caution: Maintain the closed position and the correct adjustment. Failure to do so may result in serious injury.





Tire Inspection

Tires must be maintained properly to ensure road holding and stability. Check the following areas:

Inflation: Ensure tires are inflated to the pressure indicated on the tire sidewalls. It is better to use a tire gauge and a hand pump than a service station pump.

Caution: If inflating tires with a service station pump, take care that sudden over inflation does not cause tire to blow up.

Bead

Seating: When inflating or refitting tire, make sure that the bead is properly seated in the rim.

Tread: Check that the tread shows no signs of excessive wear or flat spots, and that there are no cuts or other damage.

Caution: Excessively worn or damaged tires should be replaced.

Valves: Make sure valve caps are fitted and that valves are free from dirt. A slow leak caused by the entry of the dirt can lead to a flat tire, and possibly a dangerous situation.

Recommended Tire pressures:

The recommended pressure molded on the sidewall of your bicycle tires should match the following chart. Use this as a general guide.

BMX	35-50 p.s.i.
MTB	40-65 p.s.i.
Road Touring	70-90 p.s.i.
Road Racing	110-125 p.s.i.
Hybrid/Crossbike	60-100 p.s.i.

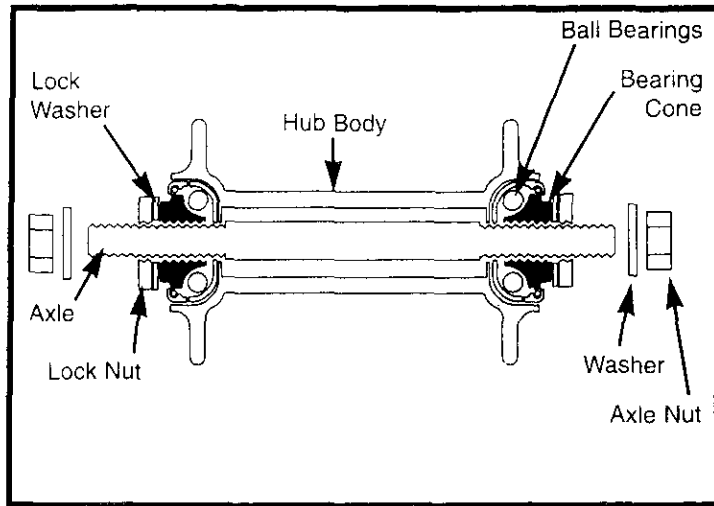

Hub Bearing Adjustment

When checked, the hub bearings of either wheel will require adjustment if there is any more than slight side play.

1. Check to make sure neither locknut is loose.
2. To adjust, remove wheel from bicycle and loosen the locknut on one side of the hub while holding the bearing cone on the same side with a flat open end wrench.
3. Rotate the adjusting cone as needed to eliminate free play.
4. Re-tighten the locknut while holding the adjusting cone in position.
5. Re-check that the wheel can turn freely without excessive side play.

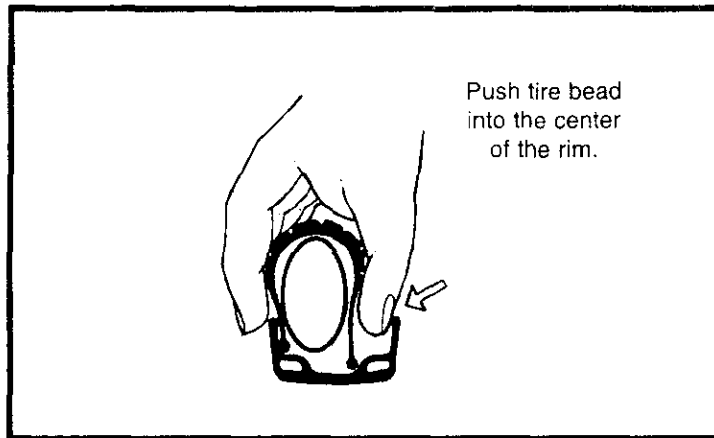

How To Fix a Flat Tire

If you need to repair a tire, follow these steps:

1. Remove the wheel from the bicycle.
2. Deflate the tire completely via the valve.
Loosen the tire bead by pushing it inward all the way around.
3. Press one side of the tire bead up over the edge of the rim.
Note: Use tire levers, not a screwdriver, otherwise you may damage the rim.
4. Remove the tube, leaving the tire on the rim.
5. Locate the leaks and patch using a tube repair kit, carefully following the instructions, or replace the tube.
Note: Ensure that the replacement tube size matches the size stated on the tire sidewall and that the valve is the correct type for your bicycle.

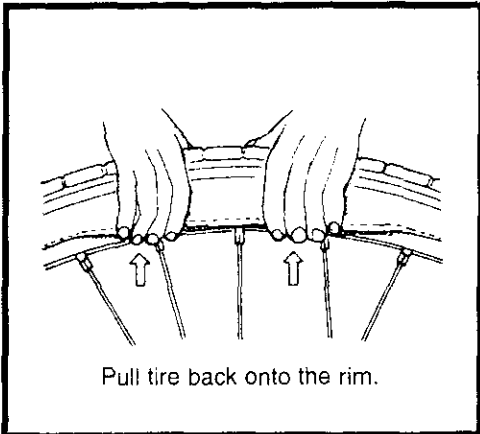
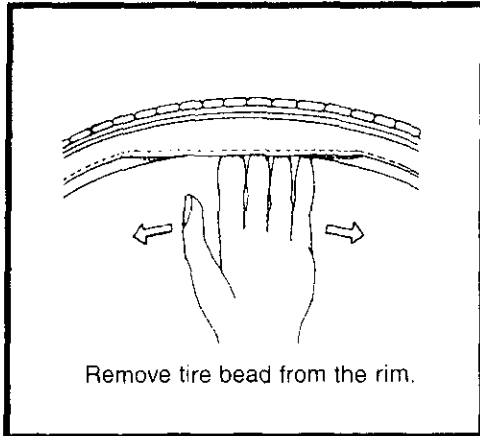

6. Match the position of the leak in the tube with the tire to locate the possible cause and mark the location on the tire.
7. Remove the tire completely and inspect for a nail, glass, etc. and remove if located. Also inspect the inside of the rim to ensure there are no protruding spokes, rust or other potential causes. Replace the rim tape which covers the spoke ends, if damaged.
8. Remount one side of the tire onto the rim.
9. Using a hand pump, inflate the tube just enough to give it some shape.
10. Place the valve stem through the hole in the rim and work the tube into the tire. Note: Do not let it twist.
11. Using your hands only, remount the other side of the tire by pushing the edge toward the center of the rim. Start on either side of the valve and work around the rim.
12. Before the tire is completely mounted, push the valve up into the rim to make sure the tire can sit squarely in position.
13. Fit the rest of the tire, rolling the last, most difficult part on using your thumbs. Note: Avoid using tire levers as these can easily puncture the tube or damage the tire.
14. Check that the tube is not caught between the rim and the tire bead at any point.
15. Using a hand pump, inflate the tube until the tire begins to take shape, and check that the tire bead is evenly seated all the way around the rim. When properly seated, fully inflate the tire to the pressure marked on the sidewall. Use a tire air pressure gauge to check.
16. Replace the wheel into the frame checking that all gears, brakes and quick release levers are properly adjusted.



HANDLEBARS AND STEM

Handlebar Stem

The handlebar stem fits into the steering column and is held firm by the action of a binder bolt and expander wedge which, when tightened, binds with the inside of the fork steerer tube.

When removing the stem, loosen the stem bolt two or three turns, then give it a tap to loosen the wedge inside.

Lubricate by first wiping off any old grease and grime, then applying a thin film of grease to the part, including the wedge, that will be inserted into the frame.

The height of the handlebar can be adjusted to suit your comfort preference.

If the stem is removed from the steering column, you will notice a mark about 65mm up from the bottom with the words "max. height" or "minimum insertion".

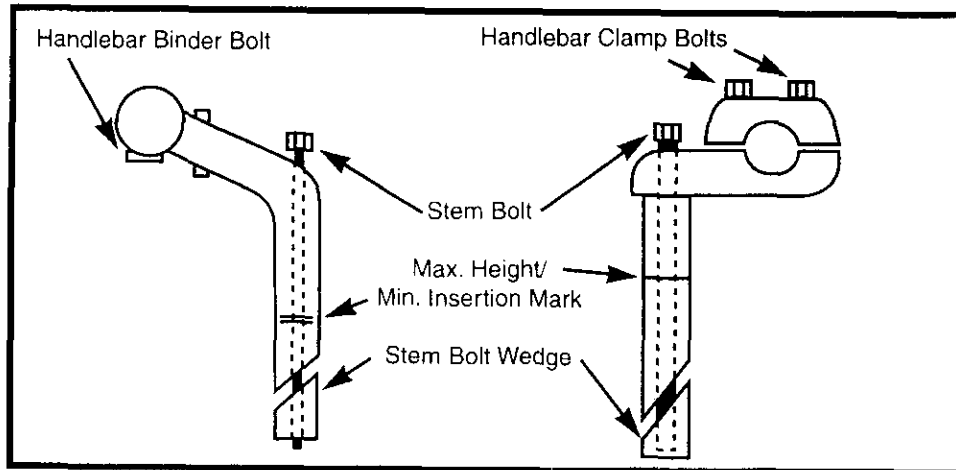
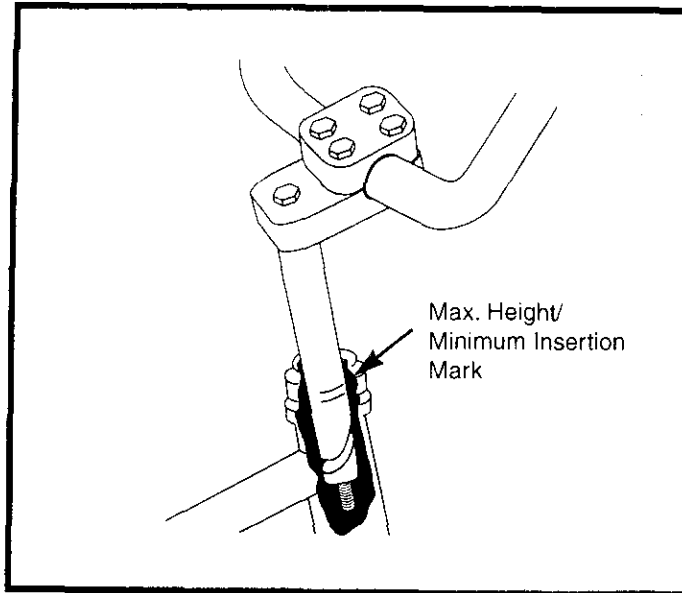

Never ride a bicycle if the stem has been raised so that the max. height/ minimum insertion line can be seen.



Warning: Overtightening the stem bolt or headset assembly may cause damage to the bicycle and/or injury to the rider.

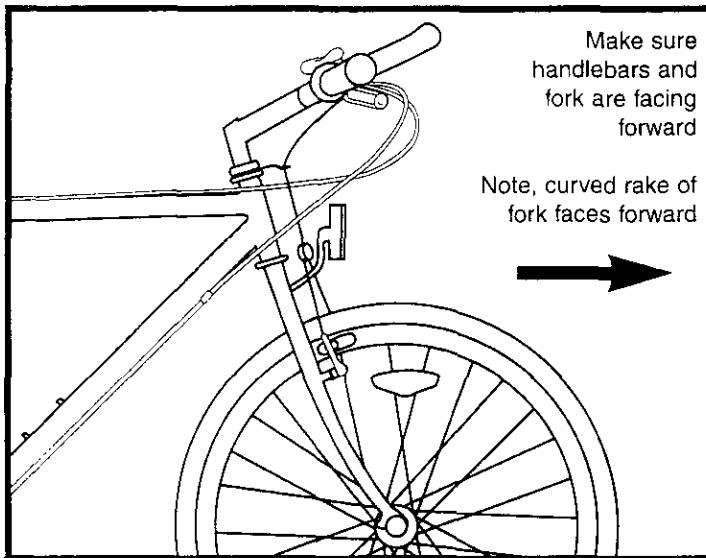
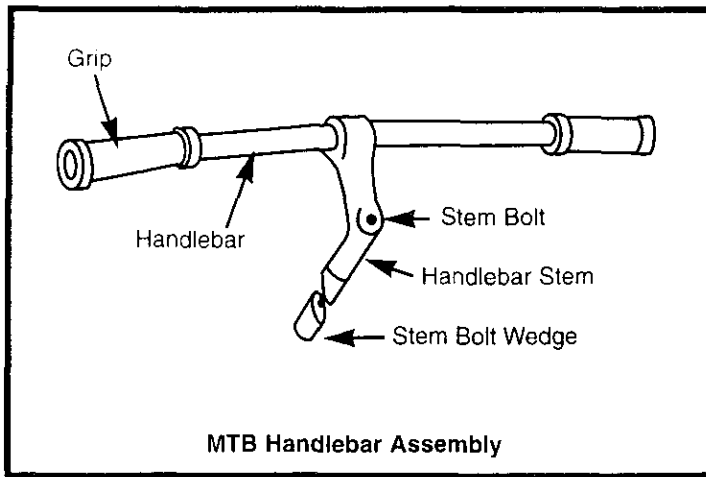

When re-fitting the stem, make sure the handlebars are correctly aligned and tightened using the appropriate hex wrench or allen key.

Do not over tighten.

Test the security of the handlebar within the stem, and the stem within the fork steerer tube, by clamping the front wheel between your knees and trying to move the handlebar up and down, and from side to side. The handlebar should not move when applying turning pressure.

Handlebars

The exact positioning of the handlebar is a matter of personal comfort. For MTB bicycles, the bar should be approximately horizontal, with the ends pointing back and slightly up. On BMX bicycles, the handlebar should remain in an approximately upright position but can be angled back or forward slightly for comfort. On MTB and racing style bicycles, the handlebar is usually tightened in the stem by a single allen key bolt or hexagonal bolt. On BMX style bicycles there may be four clamping bolts.

Make sure, when setting the handlebars in the fork, that the curved rake of the fork is angled to the front of the bicycle.

Please note that if you need to replace the forks in your bicycle at any time, the replacement forks must have the same rake and the same tube inner diameter as those originally fitted to the bicycle.

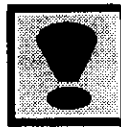

Never ride unless the handlebar clamping mechanism has been securely tightened.

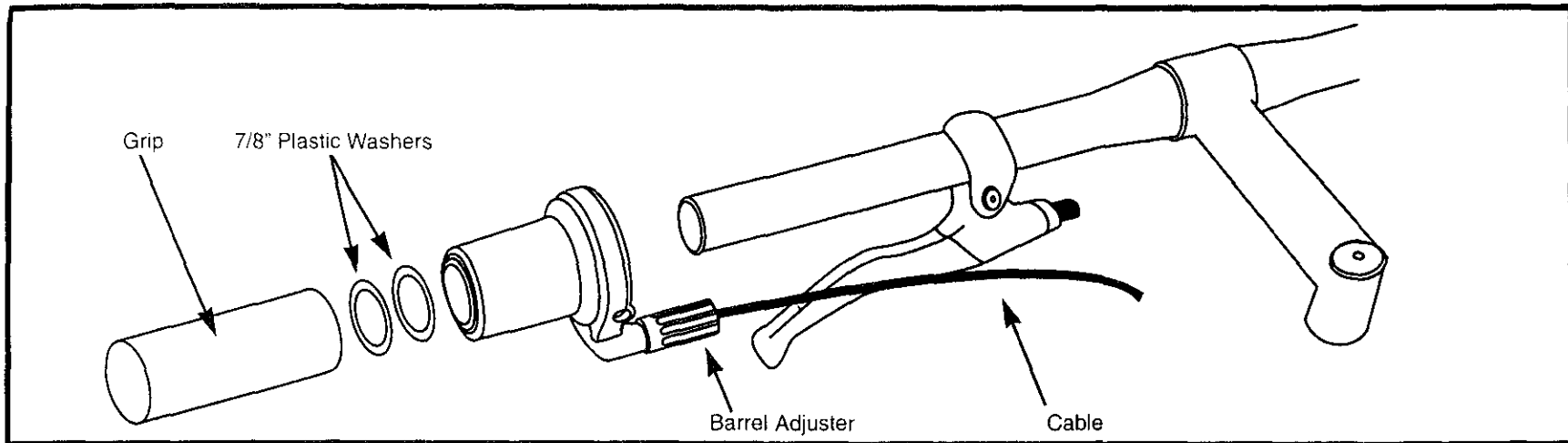

GRIP SHIFTERS

Grip Shift - Installation

1. Slide front Grip Shift assembly over left side of handlebar leaving proper clearance for handlebar grip.
If necessary, move the brake lever to accommodate Grip Shift and handlebar grip.
2. Rotate assembly until cable exits beneath brake lever with adequate clearance for brake lever movement.
3. Firmly tighten recessed clamp screw. Installation torque should be 20 in.-lbs.
4. Slide the two 7/8" plastic washers over handlebar. The washers prevent the grip from interfering with Grip Shift rotation.
5. Slide handlebar grip over handlebar. Thread the cable inner wire through cable housings and frame, and attach to derailleur. Make sure that the cable is in the V groove at the derailleur attachment bolt. If trimming the cable housing is necessary, be sure to replace the housing end cap.
6. Adjust indexing.
7. Slide rear Grip Shift over right side of handlebar and repeat steps 2 - 6.
8. Actuate front and rear brake levers to be certain of proper operation. If Grip Shift interferes with brake lever movement, rotate brake lever or Grip Shift. **Check for proper brake lever operation again.**



Cables and Cable Housing

Cables and housing are one of the most overlooked parts on the bicycle. The first indication that your cables and housing need to be replaced is an increased amount of pressure needed to operate the brakes or shifters. Before every ride, check that there are no kinks or frays in the cables and housing. Also check that the housing is seated properly into each cable stop of the bicycle. It is recommended that the cables and housing are replaced at least every riding season to prolong the life of your bike.



Do not ride a bicycle that is not operating properly.

HEADSET

Inspection

The headset bearing adjustment should be checked every month. This is important as it is the headset which locks the fork into the frame, and if loose, can cause damage or result in an accident.

While standing over the frame top tube with both feet on the ground, apply the front brake firmly and rock the bicycle back and forth; if you detect any looseness in the headset, it will need adjustment. Check that the headset is not over tight by slowly rotating the fork to the right and left. If the fork tends to stick or bind at any point, the bearings are too tight.

Adjustment

Loosen the headset top locknut or remove it completely along with the reflector bracket, if fitted. Turn the adjusting cup clockwise until finger tight. Replace the lock washer or reflector bracket and re-tighten the lock nut using a suitable wrench.

Note: Do not over tighten or bearing damage will occur.



Always make sure that the headset is properly adjusted and that the headset locknut is fully tightened before riding.



Warning: Overtightening the stem bolt or headset assembly may cause damage to the bicycle and/or injury to the rider.

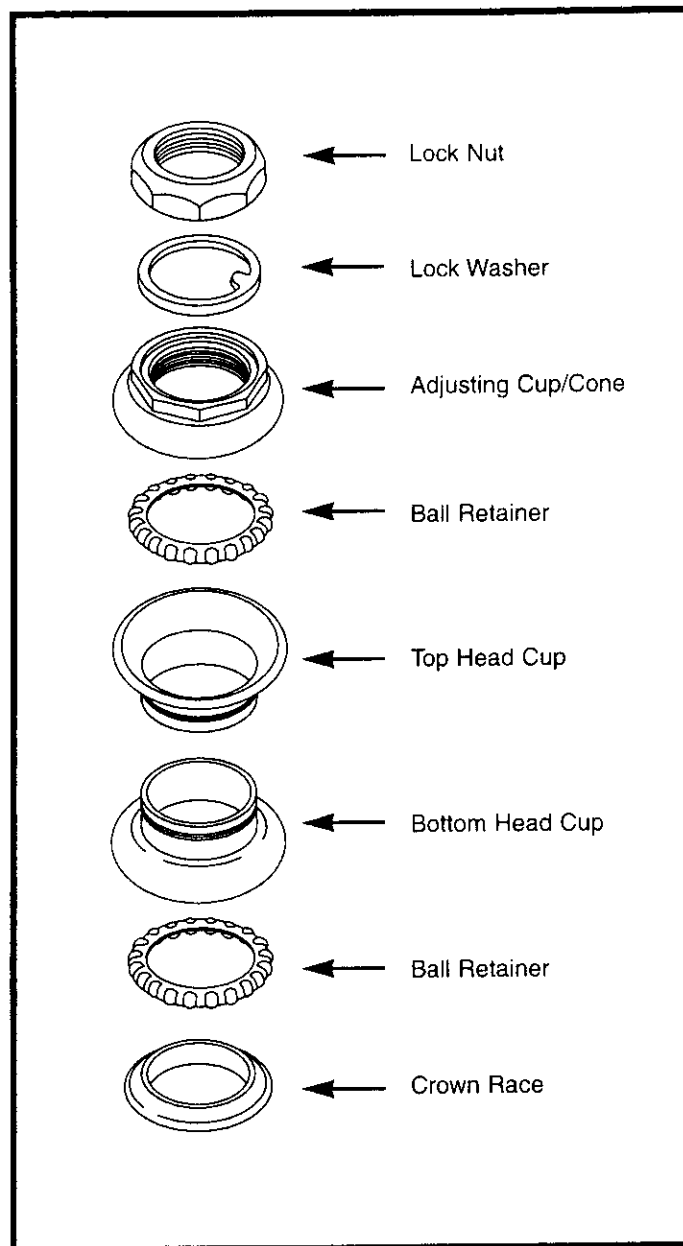

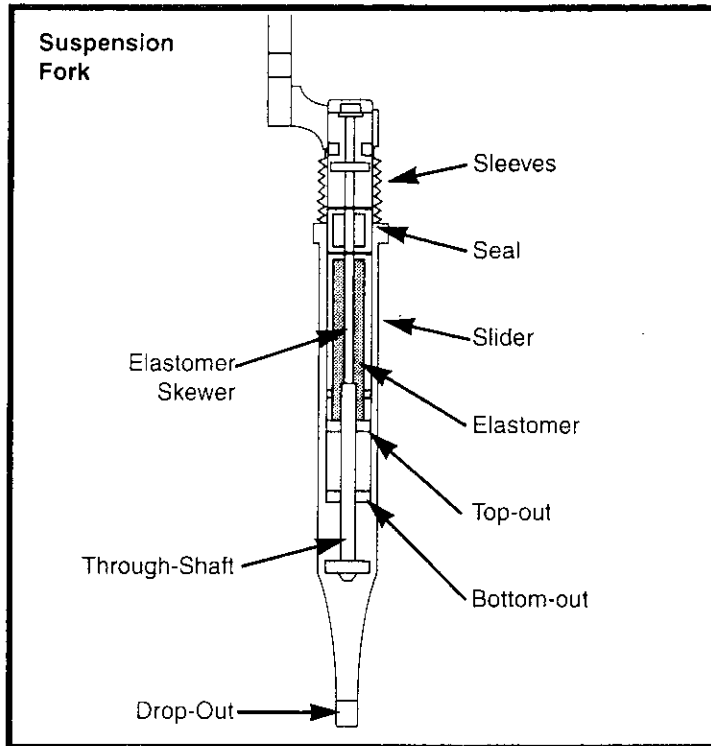

SUSPENSION FORK

Some fork models differ from the one illustrated. Those models are not adjustable and require no maintenance other than keeping it free from dirt and grime.

RST - Regular Maintenance

The following maintenance should be performed every month (if riding off-road), or whenever you feel performance is deteriorating.

1. With the fork apart, thoroughly clean all parts.
2. Apply a thin coat of grease to the upper tubes, coil springs, and all internal bushings.

RST - Reassembly

1. Slide upper tubes into lower tubes.
2. Firmly hold lower tube and turn clockwise until it will not turn anymore.
3. Align the brake arch mounts on both lower tubes and install brake arch.
4. Tighten brake arch bolts to 70-80 in.-lbs (8-9.2 Nm).

Check before each ride:

1. Make sure the headset is properly secured.
2. Make sure the exposed portions of the upper tubes are clean.
3. Make sure the quick releases are properly secured.
4. Make sure the front brake cable housing is properly seated into the brake cable stop.
5. Check tire clearance and clearance between the top of the front brake straddle cable carrier and the bottom of the cable stop. Make sure the front brake cable is routed to the brake cable stop located on the brake arch. Do not route the cable through the stem or any other mounts or cable stops.



SADDLE AND SEAT POST

Inspection

The seat fixing bolt and the seat post binder bolt should be checked for tightness and adjustment every month. On removing the seat post from the frame, you will notice a mark about 65mm up from the bottom with the words "max. height" or "minimum insertion".

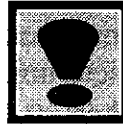

To avoid damage to either the seat post, the frame or possibly the rider, a minimum of 65mm of the seat post must always remain in the frame.

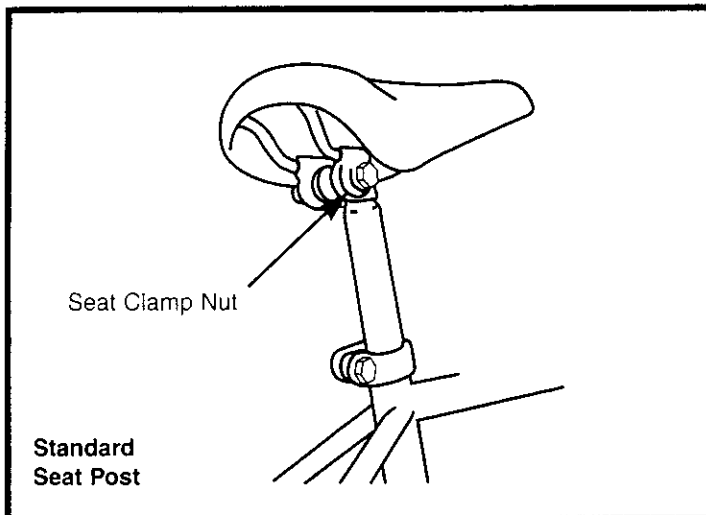
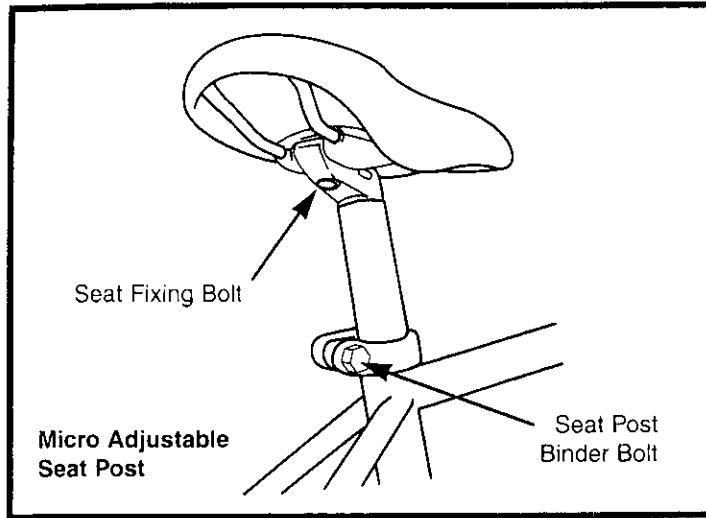

Lubrication

Remove the seat post from the frame and wipe off any grease, rust or dirt. Then apply a thin film of new grease to the part that will be inserted into the frame. Re-insert, adjust and tighten the seat post in the frame.



Adjustment

As mentioned in Part 2, the seat can be adjusted in height, angle and distance from the handlebars to suit the individual rider.

Saddle angle is a matter of personal preference but the most comfortable position will usually be found when the top of the seat is almost parallel to the ground, or slightly raised at the front.

The saddle can also be adjusted by sliding it forward or back along the mounting rails to obtain the most comfortable reach to the handlebars.

When fitting, position the seat post into the clamp under the seat and place it in the frame without tightening. Adjust it to the desired angle and position, and tighten the clamping mechanism.

There are two types of seat clamps commonly in use. The most common employs a steel clamp with hexagonal nuts on either side to tighten. The other type, known as a micro-adjustable clamp, uses a single vertically mounted Allen head fixing bolt to tighten. After fixing the seat to the desired position on the post, adjust the height to the required level and tighten the binder bolt.

Note that the type of binder bolt may be either a hexagonal bolt, an Allen head bolt, or a quick release mechanism. The operation of a seat post quick release mechanism is the same as for quick release hubs.

Refer to p.22.

Test the security by grasping the seat and trying to turn it sideways. If it moves, you will need to further tighten the binder bolt.

Note: Remember that the minimum insertion mark must remain inside the frame assembly.



BRAKES

The correct adjustment and operation of your bicycle's brakes is extremely important for safe operation. Brakes should be checked for effective operation before every ride. Frequent checking of adjustment is necessary as the control cables will stretch and the brake pads will become worn with use.

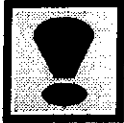

Never ride a bicycle unless the brakes are functioning properly.

There are two types of hand operated bicycle brakes in common use: sidepull calipers and cantilever calipers. Both utilize a handlebar mounted lever which controls a cable to operate the brake. Sidepull brakes are mounted to the frame or fork via a single pivot point. Cantilever brakes use two brake pivot arms, each mounted on separate pivots on either side of the frame/fork.

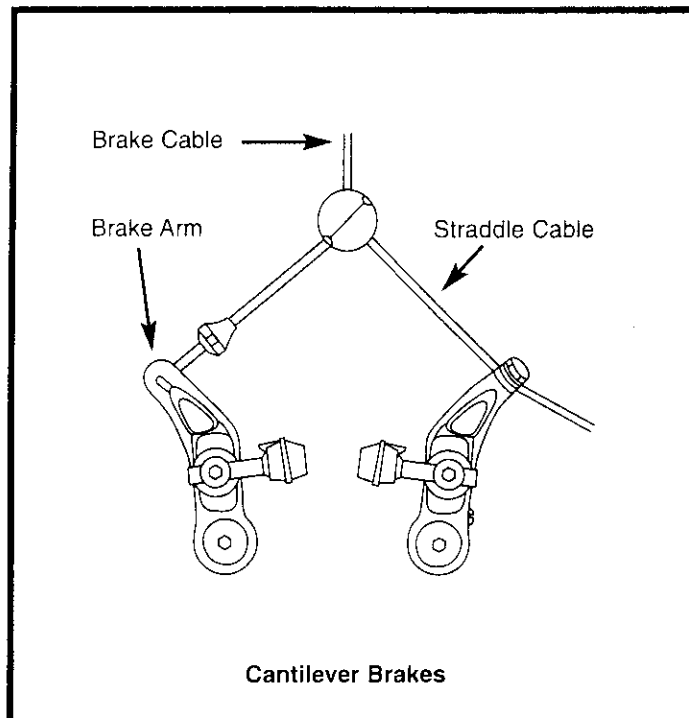

Inspection

Brake levers should be checked for tightness at least every three months. They should be set in a comfortable position within easy reach of the rider's hands, and must not be able to move on the handlebar. Some brake levers make use of a reach adjustment screw, which can be altered to the distance between the handlebar grip and the lever, as required. The brake pads should be checked for correct positioning and tightness before every ride, and the various bolts and nuts at least every three months. Squeeze each brake lever to make sure they operate freely and that the brake pads press hard enough on the rims to stop the bike. There should be about 1mm - 2mm clearance between each pad and the rim when the brakes are not applied. The brake pads must be properly centered for maximum contact with the rim. Replace the brake pads if they are over worn so that the grooves or pattern cannot be seen. The brake cable wires should be checked for kinks, rust, broken strands or frayed ends. The outer casing should also be checked for kinks, stretched coils and other damage. If the cables are damaged, they should be replaced.



Some brakes have a quick release mechanism to allow easier wheel removal. Whenever you adjust the brakes, make sure the quick release mechanism is in the closed position.



Never ride unless the quick release is firmly locked in the closed position.

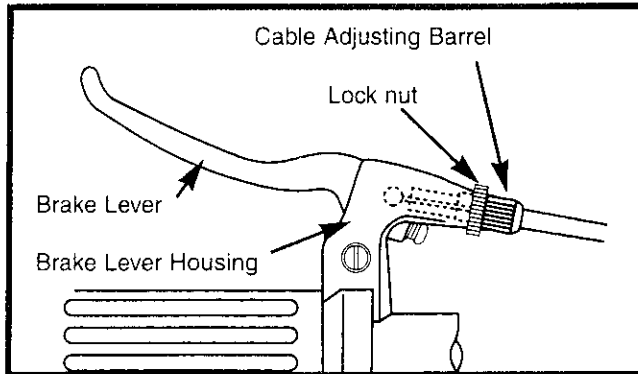

Lubrication

The brake lever and brake caliper pivot points should be oiled with 2-3 drops of light oil at least every three months to ensure smooth operation and to reduce wear. Cables should be greased along their entire length, after removing them from their casings, at least every six months. Always grease new cables before fitting.

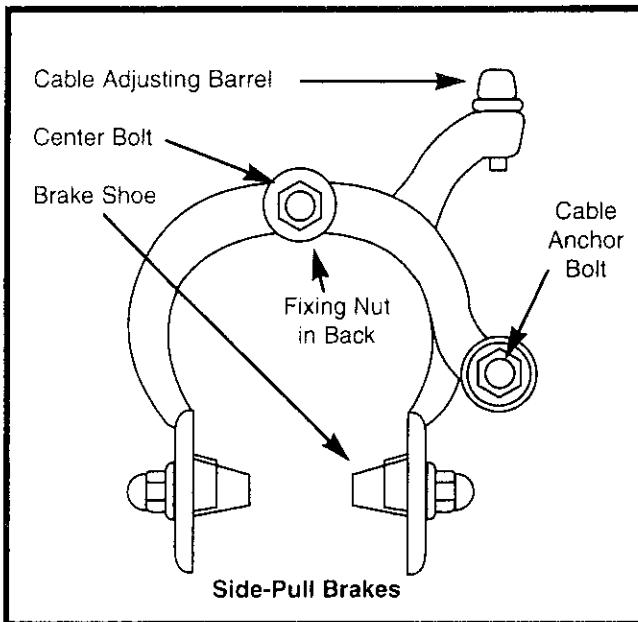

Adjustment - Sidepull Calipers

Minor brake adjustment can be made via the cable adjusting barrel, usually located at the upper cable arm. To adjust, squeeze the brake pads against the rim, loosen the lock nut and turn the adjuster. Brake pad clearance should be a maximum 2mm from the rim. When correct, re-tighten the lock nut. If the pads cannot be set close enough to the rim in this manner, you may have to adjust the cable length. Screw the barrel adjuster 3/4 of the way in, squeeze the pads against the rim, undo the cable anchor bolt and pull the cable through with pliers. Re-tighten the cable anchor bolt and apply full force to the brake lever to test, then fine tune using the barrel adjuster. If one pad is closer to the rim than the other, loosen the fixing nut at the back of the brake, apply the brake to hold it centered, and re-tighten the fixing nut.



Ensure the Brake fixing nut is secured tightly. Failure to do this may cause the Brake assembly to dislodge from the fork.

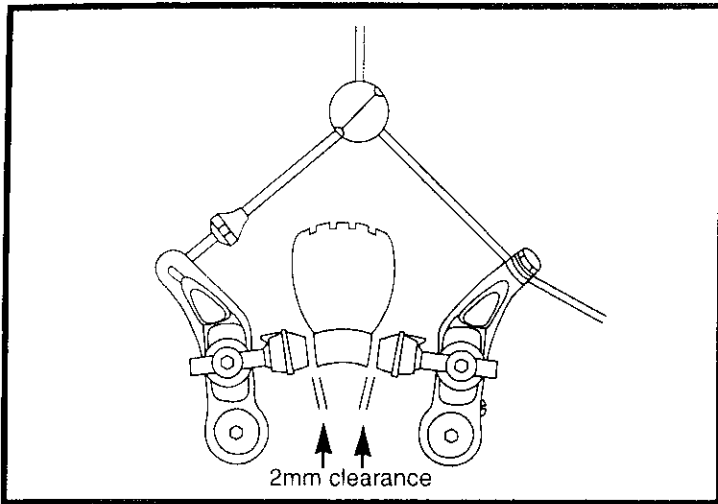

Some brakes have a special mechanism which enables you to set the clearance on either side of the rim using a screwdriver. Brake pads should finally be adjusted so that the leading edge of the pad makes first contact with the rim. Some brakes have special curved washers to allow this, but on less complex models it will be necessary to apply a little force to the pad and its mounting.

Adjustment - Cantilever Calipers

Minor brake adjustment can be made via the barrel cable adjusters which are located on each brake lever. To adjust, squeeze the brake pads against the rim, loosen the lock nut, and turn the adjuster to pull the brake pads closer to, or spread them away from the rim as required. Brake pad clearance should be a maximum 2mm from the rim.

When correct, re-tighten the lock nut.

If the pads cannot be set close enough to the rim in this manner, you may have to adjust either the length of the straddle cable or the length of the brake cable.

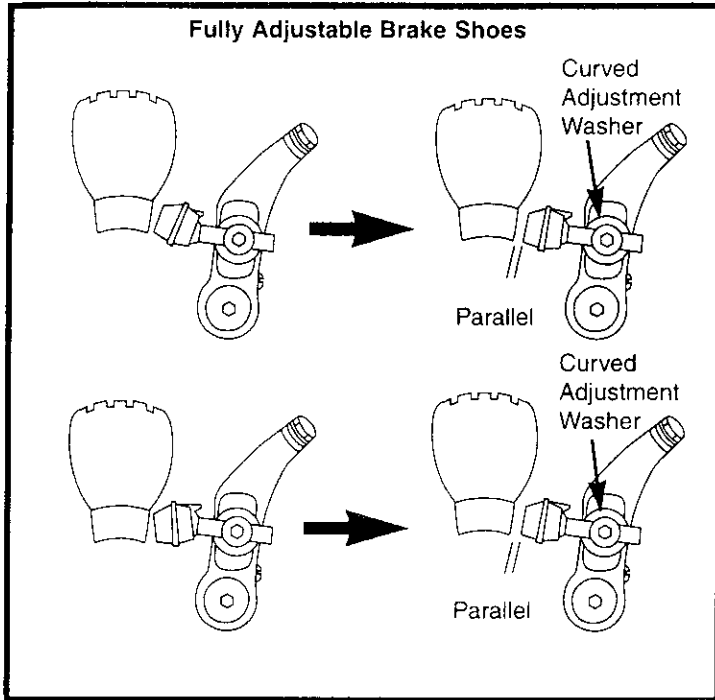

If the brakes use a separate brake cable and straddle cable, adjust the straddle length by first screwing the barrel adjuster 3/4 of the way in, then loosening the straddle cable fixing bolt, then pulling or pushing the cable through the fixing bolt to adjust the length, and finally re-tightening the fixing bolt.

Check that the straddle bridge is in the middle of the cable to ensure even brake pad contact. Apply full force to the brake lever to test, then fine tune using the barrel adjuster.

To adjust the brake cable length, loosen the brake cable fixing bolt on the cable straddle bridge, adjust the length until the brake shoes are the correct distance from the rim, then re-tighten and test.

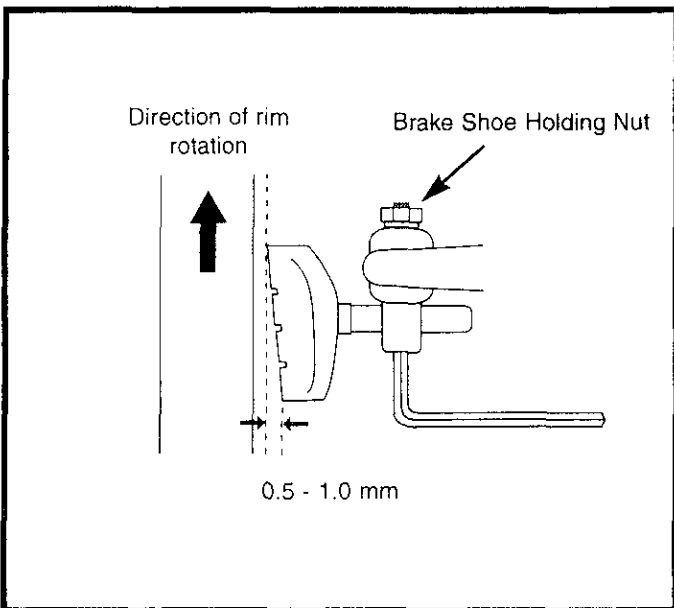
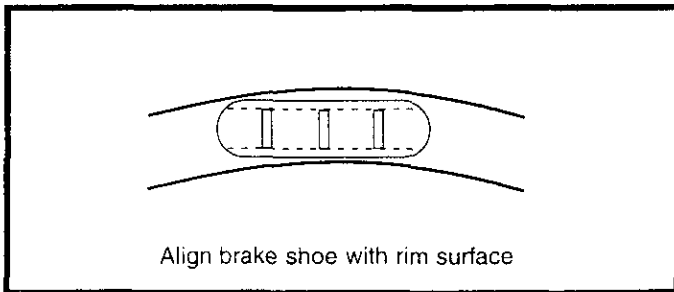
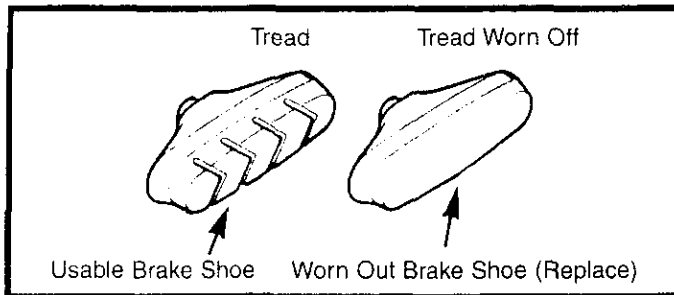

On some newer type cantilever brakes, the main brake cable continues through the central cable carrier to an anchor bolt on one of the brake arms. A shorter link cable reaches from the carrier and the hook on the other brake arm. Adjustment of the cable length is made after loosening the anchor bolt on the brake arm.

Adjust the brake pad position so that it is parallel to the wheel rim and so that the leading edge makes first contact. To do this, fit an Allen key into the brake pad holding bolt, loosen the fixing nut and adjust. Move the brake pad along its mounting post to alter the distance from the rim, and move the curved adjustment washer to alter the angle of the pad.

On some models there is a spring-force adjustment screw on the brake arm which allows further fine tuning of the brake shoe position.

Bicycles with cantilever brakes must be fitted with safety devices to prevent a possible accident in the event of the brake control cable or the straddle bridge becoming loose or breaking while riding. These are usually the reflector brackets, and must be fitted in the front and rear. The bracket will prevent the straddle cable from interfering with the wheel should the cable become disconnected from the control cable. If the reflector brackets are not fitted in this position, then alternative emergency cable safety stops must still be fitted.

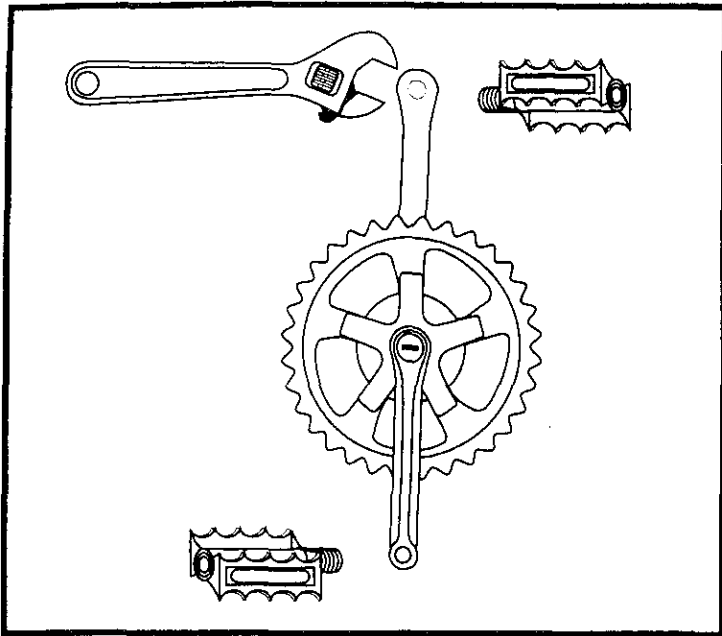

DRIVETRAIN

The drivetrain of a bicycle refers to all parts that transmit power to the rear wheel including the pedals, chain, chainwheel, crank set, and freewheel.

PEDALS

Pedals are available in a variety of shapes, sizes and materials, and each are designed with a particular purpose in mind. Some pedals can be fitted with toe clips and straps. These help to keep the feet correctly positioned and allow the rider to exert pulling force, as well as downward pressure, on the pedals. Use of toe clips with straps requires practice to acquire the necessary skill to operate them safely.

Inspection

Pedals should be inspected every month, taking note of the following areas:

- Check correct tightness into the crank arms. If pedals are allowed to become loose, they will not only be dangerous but will also cause irreparable damage to the cranks.
- Check that pedal bearings are properly adjusted. Move the pedals up and down, and right to left, and also rotate them by hand. If you detect any looseness or roughness in the pedal bearings then adjustment, lubrication or replacement is required.
- Ensure that the front and rear pedal reflectors are clean and securely fitted.
- Also ensure that the toe clips, if fitted, are securely tightened to the pedals.

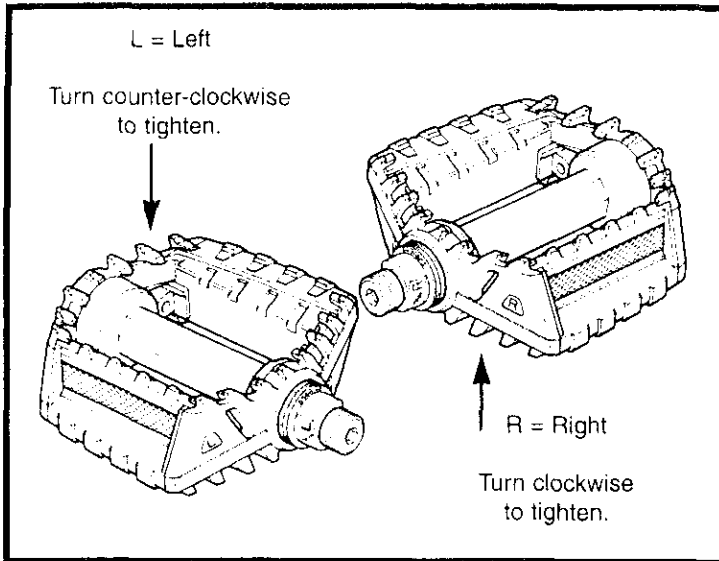

Never ride with loose pedals.

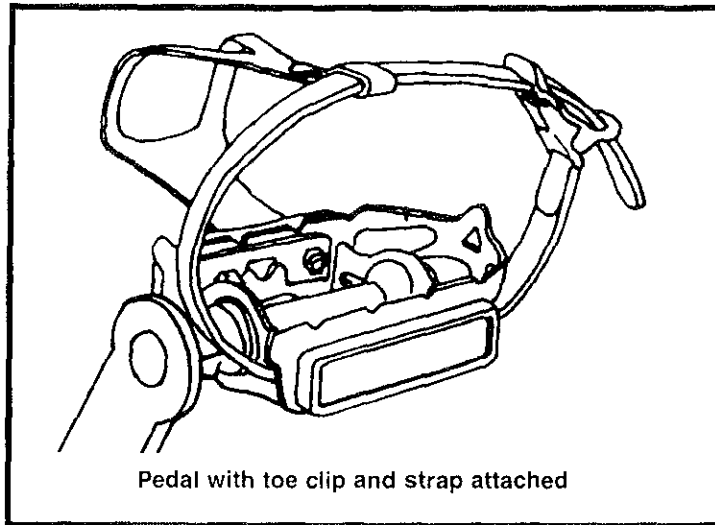

Lubrication and Adjustment

Many pedals cannot be disassembled to allow access to the internal bearings and axle. However, it is usually possible to inject a little oil onto the inside bearings, and this should be done every six months. If the pedal is the type that can be fully disassembled, then the bearings should be removed, cleaned and greased every six to twelve months. Because of the wide variety of pedal types and their internal complexity, disassembly procedures are beyond the scope of this manual and further assistance should be sought from a specialist.



Never ride in traffic with fully tightened toe straps.

Attachment

Note: The right and left pedals of a bicycle each have a different thread and are not interchangeable.

Never force a pedal into the incorrect crank arm.

The right pedal, which attaches to the chainwheel side, is marked 'R' on the end of the axle, and screws in with a clockwise thread. The left pedal, which attaches to the other crank arm, is marked 'L' on the axle, and screws in with a counter-clockwise thread.

Insert the correct pedal into the crank arm and begin to turn the thread with your fingers only. When the axle is screwed all the way in, securely tighten using a 15mm wrench.

If removing a pedal, remember that the right pedal axle must be turned counter clockwise, i.e. the reverse of when fitting. If replacing the original pedals with a new set, make sure the size and the axle thread is compatible with the cranks on your bicycle. Bicycles use one of two types of cranks and these use different axle threads. Your bike may be equipped with cranks that are a one piece design with no separate axle. These operate with pedals that have a 1/2"(12.7mm) thread. Bikes equipped with three piece crank sets with a separate axle, left crank and right crank, use a slightly larger 9/16"(14mm) thread.

Note: Never try and force a pedal with the wrong thread size into a bicycle crank.

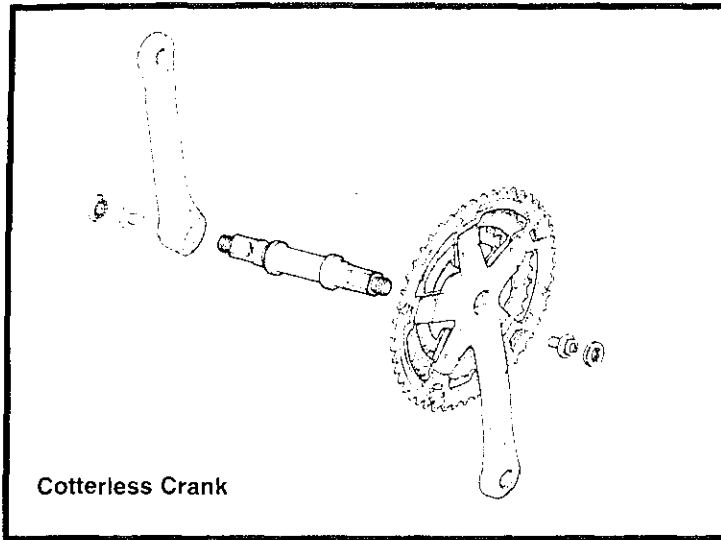

CRANK SET

The crank set refers to the bottom bracket axle and bearings, the crank arms, and chainrings.

Your bike may be fitted with either a one piece crank, where the crank arms and bottom bracket are a single component, or cotterless cranks, where the crank arms bolt onto the bottom bracket axle without using old fashioned type cotterpins. The one piece system is simpler and requires less maintenance, while the cotterless system requires a little extra care.

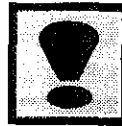

Never ride your bike if the cotterless cranks are loose. This may be dangerous and will damage the crank arms beyond repair.

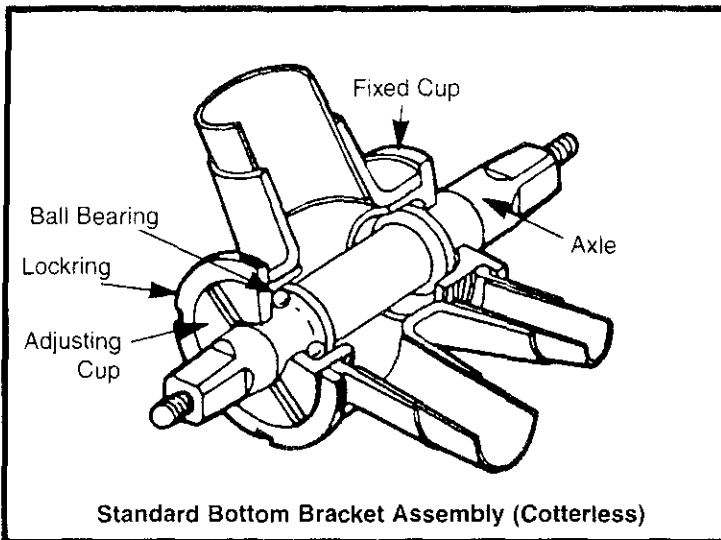

Inspection

The crank set should be checked for correct adjustment and tightness every month. Cotterless crank axle nuts must be kept tight, and the bottom bracket bearings must be properly adjusted.

Remove the chain and try to move the cranks from side to side with your hands. The cranks should not move on the axle, and there should be only very slight movement in the bottom bracket. Next, spin the cranks. If they don't spin freely without grinding noise, then adjustment or lubrication will be needed. Also check that there are no broken teeth on the chainrings, and wipe off excess dirt and grease that may have built up on them.



Lubrication and Adjustment - One Piece Cranks

To adjust the free play in a one piece type bottom bracket, loosen the locknut on the left side by turning it clockwise and tighten the adjusting cone counter-clockwise using a screwdriver in the slot. When correctly adjusted, re-tighten the locknut counter-clockwise.

To disassemble:

1. Remove the chain from the chainwheel.
2. Remove the left pedal by turning the spindle clockwise.
3. Remove the left side locknut by turning it clockwise and remove the keyed lockwasher.
4. Remove the adjusting cone by turning it clockwise with a screwdriver.
5. Remove the left ball retainer, slide the crank assembly out of the frame to the right, and remove the right ball retainer.

Clean and inspect all bearing surfaces and ball retainers, and replace any damaged parts. Pack the ball bearing retainers with grease, then re-assemble in the reverse of the above procedure.

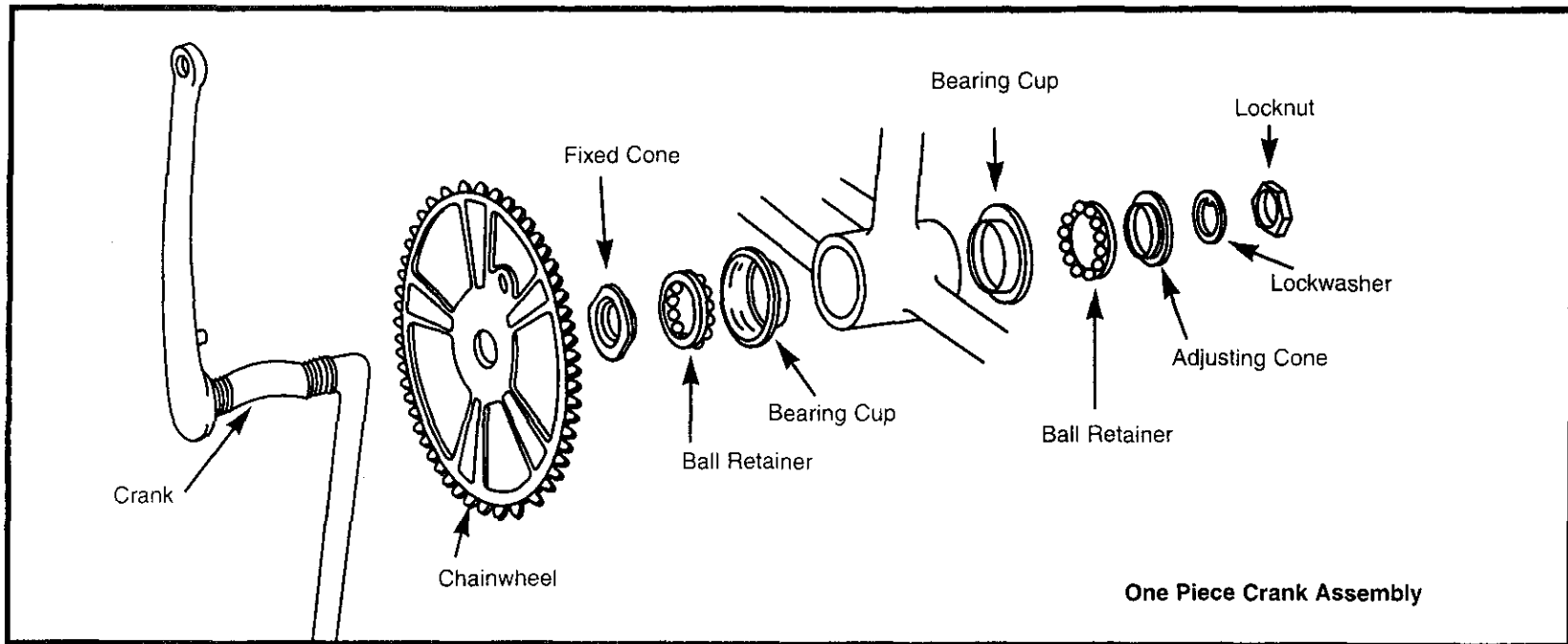

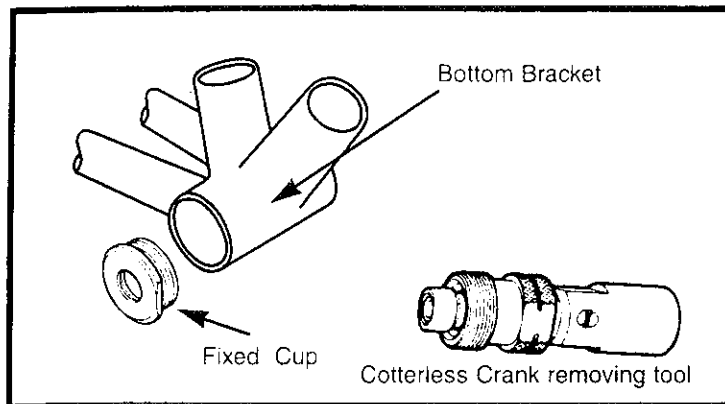

Lubrication and Adjustment - Cotterless Cranks

To adjust the free play in a three piece type bottom bracket, loosen the lockring on the left side by turning it counter-clockwise, then turn the adjusting cup as required. Re-tighten the lockring taking care not to alter the cup adjustment.

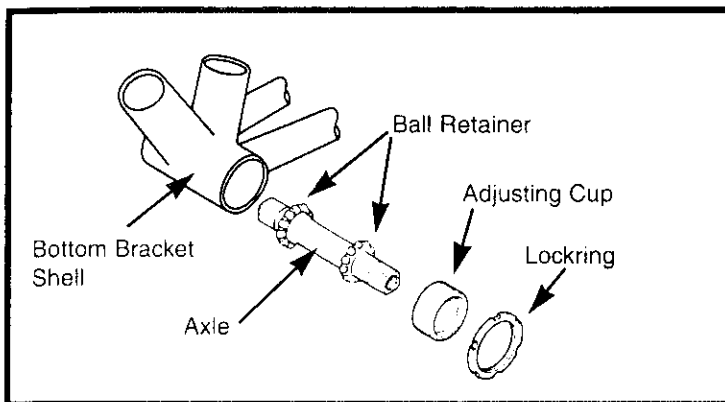

To disassemble:

1. Remove the cranks from the axle.
2. Remove the left side lockring by turning it counter-clockwise.
3. Remove the adjusting cup by turning it counter-clockwise.
4. Remove the left ball retainer and slide the axle out of the frame to the left.
5. Remove the right side fixed cup by turning it counter-clockwise and remove the right ball retainer. Clean and inspect all bearing surfaces and ball retainers, and replace any damaged parts. Pack the ball bearing retainers with grease, then re-assemble in reverse of the above procedure.

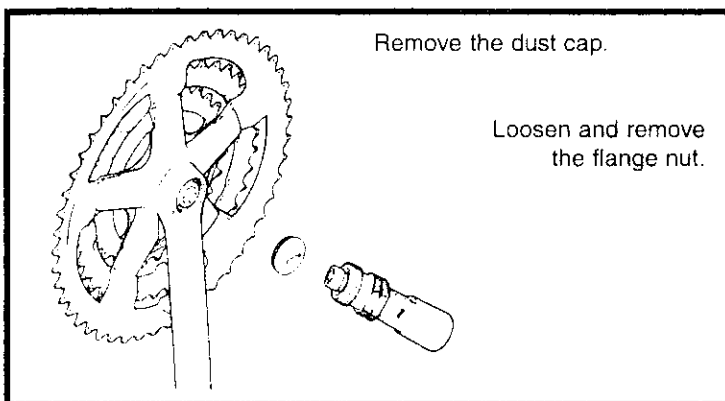

Cotterless Crank Removal

To remove cotterless cranks use the following procedure. Note that a special tool will be required.

1. Remove the dust cap with a coin or screwdriver.
2. Loosen the flange nut or bolt and washer, and remove.

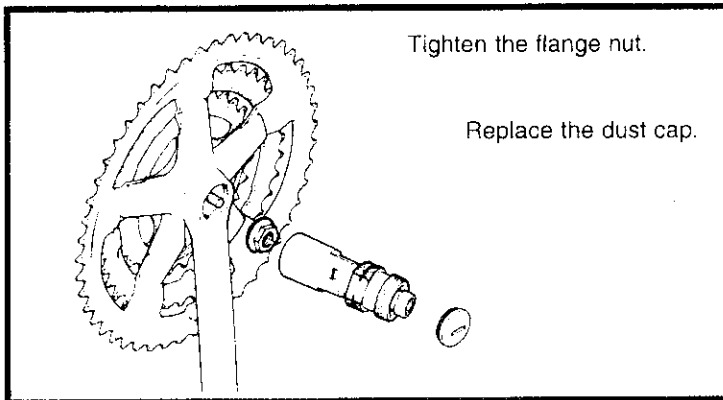
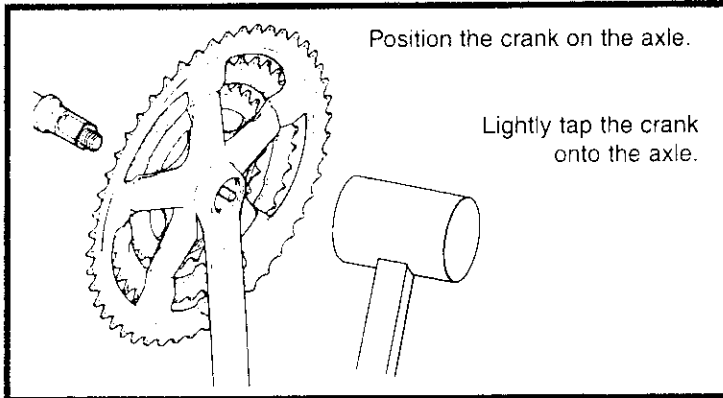
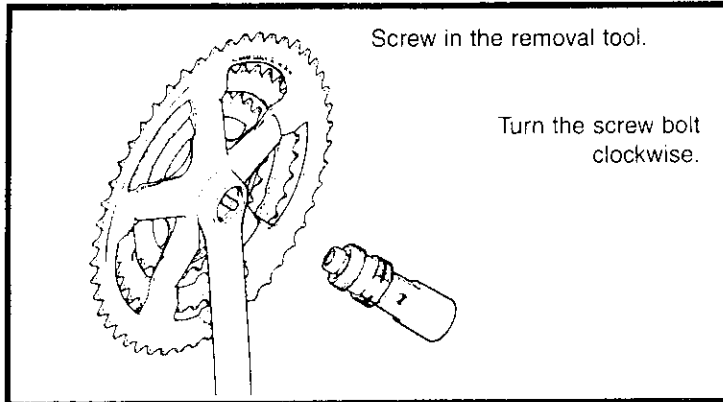

3. Screw the removing tool into the crank and tighten.
4. Turn the screw bolt down until the crank comes away from the axle.

Cotterless Crank Replacement:

1. Replace the crank arm onto the axle.
2. Tap the crank arm lightly with a mallet.
3. Refit the washer and tighten flange nut or bolt securely to a torque of 27Nm.
4. Replace the dust cover

Adjustment After Use:

1. Remove dust cap.
2. Tap the crank arm lightly with a mallet.
3. Re-tighten the flange nuts, and refit the dust caps.

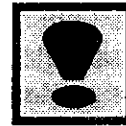

New cotterless cranks may become loose with initial use. Perform the following task after several hours of riding, and repeat it two or three times after further use. Cranks should then remain tight.

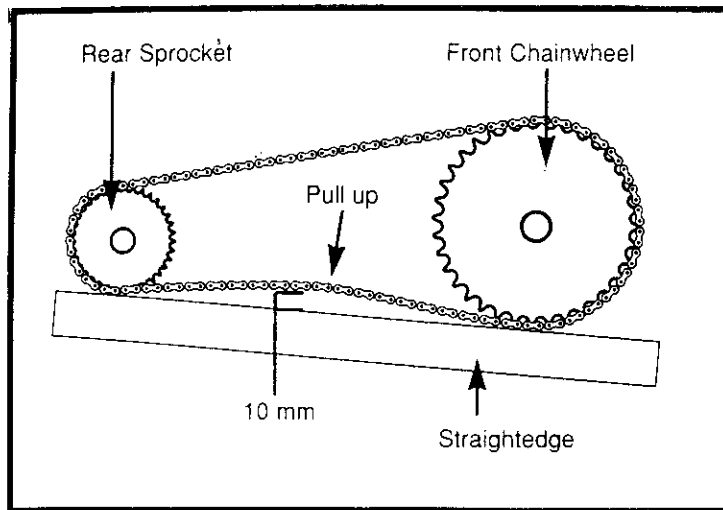

CHAIN

Inspection

The chain must be kept clean, rust free and frequently lubricated in order to extend its life as long as possible. It will require replacement if it stretches, breaks, or causes inefficient gear shifting. Make sure that there are no stiff links, they must all move freely.

Lubrication

The chain should be lubricated with light oil at least every month, or after use in wet, muddy, or dusty conditions. Take care to wipe off excess oil, and not to get oil on the tires or rim braking surfaces.

Adjustment and Replacement

On derailleur geared bicycles the rear derailleur automatically tensions the chain.

To adjust the chain on single speed freewheel, coaster hub braked or 3-speed hub geared bicycles:

1. Loosen the rear axle nuts (and coaster brake arm clip if fitted) and move the wheel forward to loosen, or backward to tighten, in the frame.
2. When correctly adjusted, the chain should have approximately 10mm of vertical movement when checked in the center between the chainwheel and rear sprocket. Center the wheel in the frame and re-tighten the axle nuts after any adjustment. Bicycles which have a single speed freewheel, coaster hub brake or 3-speed hub, generally use a wider type chain than derailleur geared bicycles. These chains can be disconnected by way of a special U-shape joining link, that can be pried off of the master link with a screwdriver. To replace, feed the chain around the chainwheel and rear sprocket, fit the master link into the rollers into each end of the chain, position the master link side plate, and slip on the U-shaped snap-on plate. Make sure the open end of the U-shaped plate is trailing as the link approaches the chainwheel when pedaling forward.

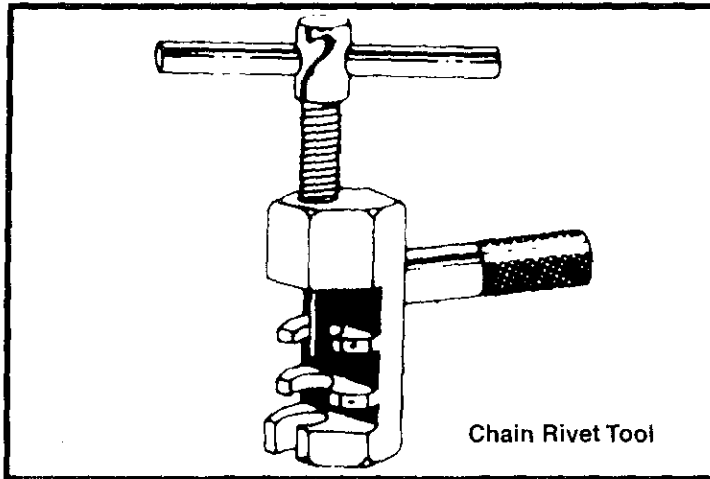

Derailleur geared bicycles use narrower chains and require a special tool to fit and remove chain links, or to change the length. To remove, fit the rivet tool so that the punch pin is centered over any one of the chain rivets. Push the rivet almost all the way out, then back out the punch and remove the tool. Holding the chain on both sides of the punched rivet, bend it slightly to release link from the rivet. To install, feed chain around chainwheel, rear sprocket and derailleur cage with rivet facing away from the bicycle. Bring the two ends together within the special tool and punch the rivet into place. Be sure not to push rivet too far through side plate.

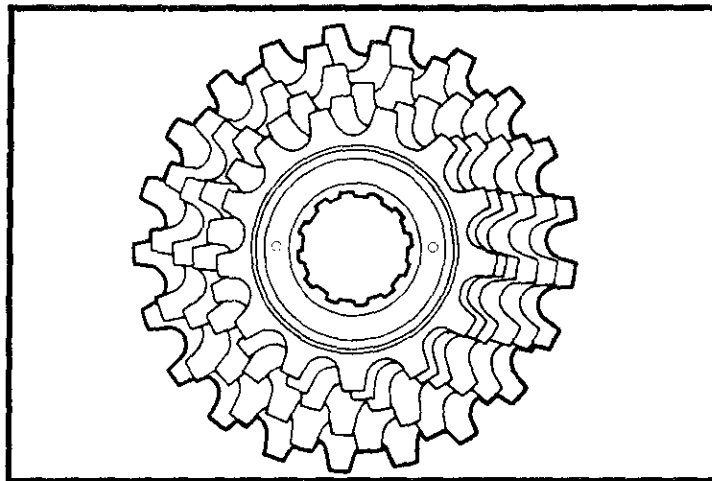

FREEWHEEL

Inspection

Like the chain, the freewheel must be kept clean and well lubricated. If the chain has become worn and needs replacing, then it is likely that the freewheel will also have become worn and should also be replaced. Take the chain off the freewheel and rotate it with your hand. If you hear a grinding noise or the freewheel stops suddenly after spinning it, it may need adjustment or replacement. Such action is beyond the scope of this manual and you should consult a specialist.

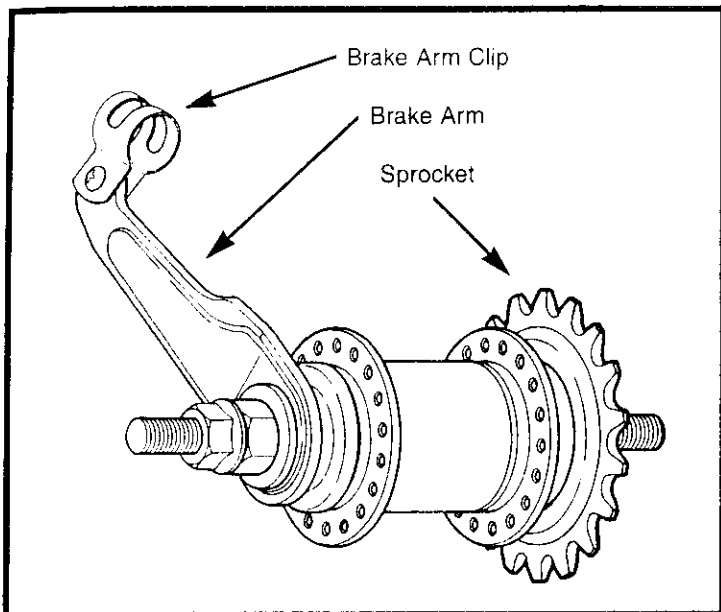

Lubrication

Remove any accumulated dirt from the freewheel with a brush and a degreaser. Disassembly of the free wheel is a complicated procedure requiring special tools, and should be left to a specialist. Apply oil to the freewheel whenever you lubricate the chain, taking care to wipe off any excess.

COASTER HUB

Many BMX style and other children's bicycles are fitted with a coaster hub brake in the rear wheel. This type of brake offers the advantages of reliability and easy operation. The brake is operated by applying back pedal pressure and allows the rider to 'coast' without pedaling, if desired. There are several models of coaster hubs available, and the internal mechanisms are very complex. They require infrequent attention as far as lubrication, adjustment or replacement of internal parts; if needed, this should be left to a specialist.

Keep the coaster hub sprocket clean and oil it along with the chain.



Make sure the brake arm is correctly attached to the chainstay with the brake arm clip. The brake will not operate otherwise.



DERAILLEUR SYSTEMS

The derailleur system includes the front and rear derailleurs, the shift levers, and the derailleur control cables, all of which must function correctly for smooth gear shifting to occur. There are several different types of derailleur systems but all operate using similar principles. Your new bicycle may be fitted with a standard 'friction' type system where you will need to feel each gear shift into position. It may be fitted with an 'index' system (e.g. SIS) which links each different gear position to a positive click mechanism in the shifter, and makes shifting very simple and precise. A further development of SIS is the fully integrated system (e.g. STI) where the shift lever and brake lever mechanisms form an integrated unit with the system allowing both gear shifting and braking to occur at the same time.

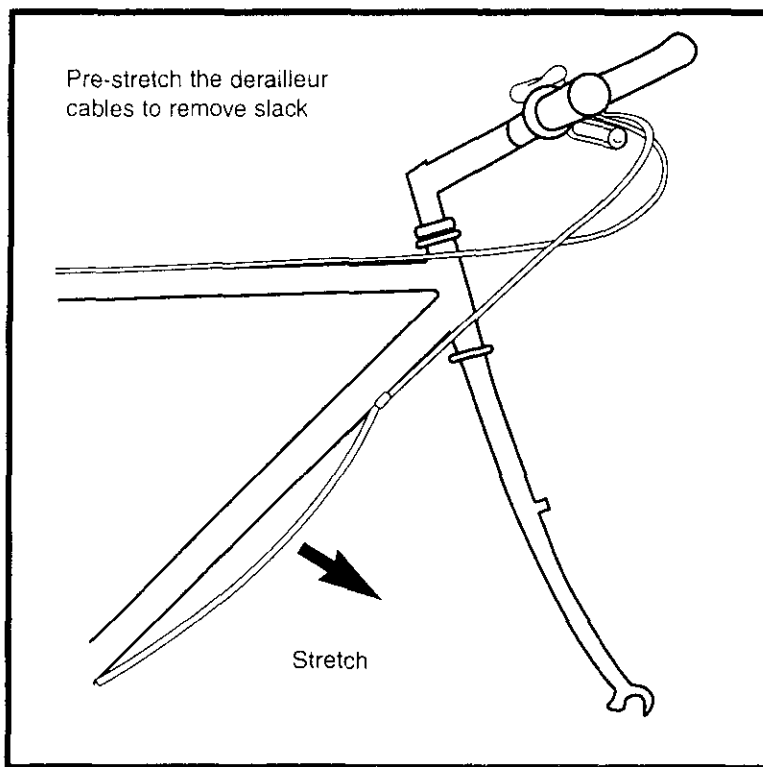

Inspection

The operation of the derailleur system should be checked at least every month. Check the operation of the rear derailleur first, then the front. The rear derailleur should shift the chain cleanly from one cog to the next without hesitation. On SIS equipped bicycles, each notched position in the shifter must equate to a new gear position. After shifting, the rear derailleur should not rub on the chain. The derailleur should never cause the chain to fall off the inner or outer freewheel cogs.

The front derailleur should also shift the chain cleanly and without hesitation between each chainring. If your bicycle is equipped with front SIS, then each click or stop in the shifter should equate exactly to a new gear position. When the chain has been positioned onto a new chainring, it should not rub on the front derailleur. The chain should not fall off a chainring at any time. Derailleur control cables are a critical component that must be well maintained for accurate shifting performance. Check them for any sign of rust, fraying, kinks, broken strands, and any damage to the cable housing. If you find any problems, the cables may need replacing before you ride.

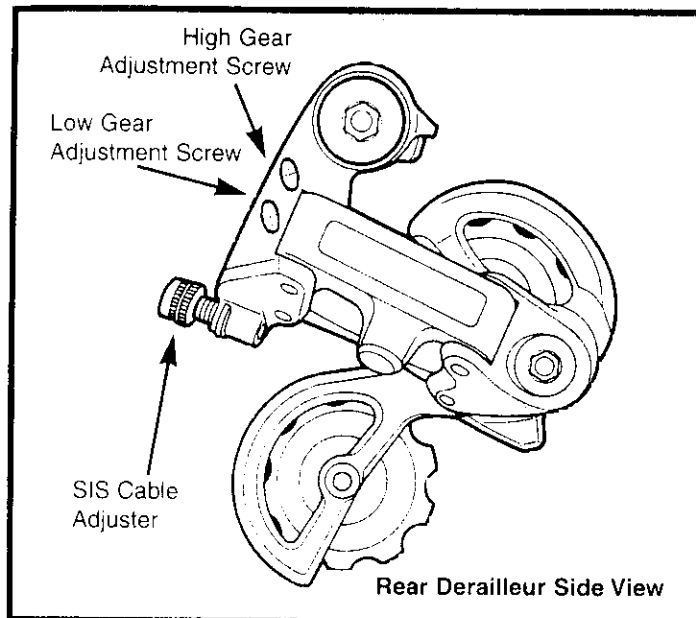
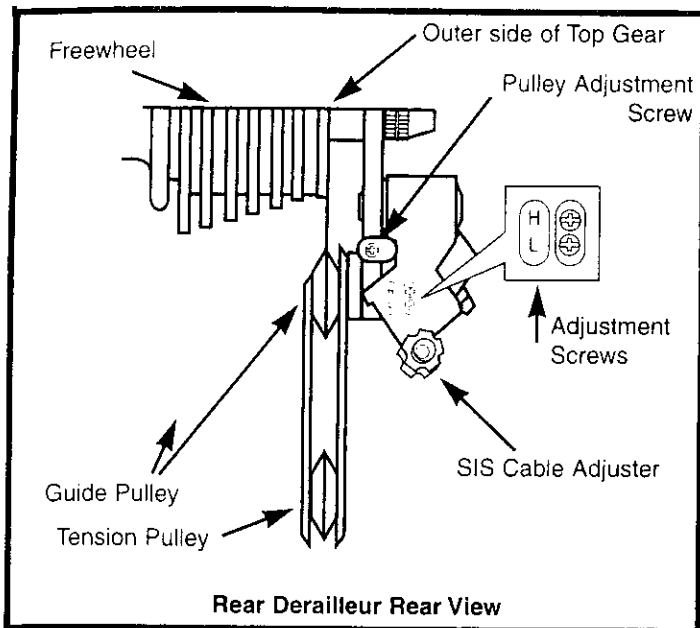

Lubrication

All the pivoting points of the front and rear derailleurs should be lubricated with light oil at least every month. Be sure to wipe off any excess oil to prevent attraction of dirt into the mechanisms. The shifting cables should be cleaned and re-coated with a thin layer of grease every six months, or whenever new cables are being installed.

Adjustment - Rear Derailleur

The Low limit screw determines how far the rear derailleur will travel toward the wheel of the bicycle, while the High limit screw determines how far the cage will travel toward the frame.

1. Shift the rear shifter to the largest number indicated, disconnect the rear derailleur cable from the cable anchor bolt and place the chain on the smallest sprocket.
2. Adjust the High limit screw so the chain and the smallest sprocket are lined up vertically. Remove any slack in the cable by pulling it taut, then re-connect the cable and tighten the cable anchor bolt securely.
3. Shift up through the gears making sure that each gear is achieved quietly and without hesitation.

If noise occurs, use the barrel adjuster to fine-tune the cable tension.

Turning the barrel adjuster **clockwise** will decrease cable tension and allow the derailleur cage to move farther away from the bicycle in small increments. Turning **counter-clockwise** will increase cable tension and bring the cage closer to the bicycle. This will micro-adjust the positioning of the derailleur cage in relation to the freewheel. Simply put; turn the barrel adjuster the direction you want the chain to go.

4. Shift the chain onto the largest sprocket; adjust the low limit screw so the chain and the largest cog are lined up vertically. If you are unable to get the chain to the largest cog, turning the Low limit screw counter-clockwise will enable the chain to move towards the wheel.
5. Shift through the gears ensuring each gear is achieved quietly and without hesitation.

NOTE: It may take several adjustments to achieve the desired positioning. Please refer to the troubleshooting section for more assistance.

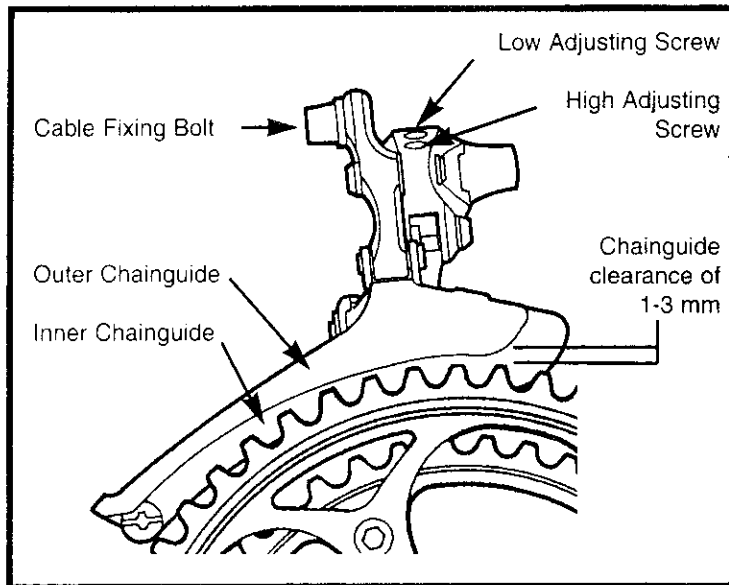

Adjustment - Front Derailleur

1. Shift the **rear** shifter to the smallest number indicated, then shift the **front** shifter to the smallest number indicated. Disconnect the front derailleur cable from the cable anchor bolt and place the chain on the smallest chainwheel.
2. Make sure the front derailleur cage is parallel with the outer chainwheel on the crankset. There must be a 3-5mm gap between the bottom of the derailleur cage and the top of the outer chainwheel teeth to ensure the derailleur will clear the chainwheel when shifting.
3. Adjust the low limit screw so the chain is centered in the middle of derailleur cage. Pull all slack out of the cable by pulling it taut, then reconnect the cable and tighten the cable anchor bolt securely.
4. Shift the front shifter into the largest gear and pedal the bike so the chain jumps to the largest chainwheel. If the chain does not shift onto the largest chainwheel, you will need to turn the High limit screw counter-clockwise until the chain moves to the largest chainwheel. If the chain falls into the pedals, the High limit screw has been turned too far. You will need to readjust the High screw clockwise in 1/4 turn increments until the chain no longer falls off.
5. Shift through each gear ensuring all are achieved quietly and without hesitation.
6. The barrel adjuster for the front derailleur is located on the shift mechanism. Turning clockwise will decrease cable tension and allow the front derailleur cage to move away from the bike, while turning counter-clockwise will increase tension and bring the cage closer to the bike. If you are experiencing problems shifting between gears, use the barrel adjuster to fine-tune the cable tension.

NOTE: It may take several adjustments to achieve the desired positioning.



QUICK RELEASE LEVERS

It is important to check the quick release levers before every ride to ensure all connections are made properly and securely. Periodically, disassemble the mechanism from the bicycle and inspect for any wear or damage and replace if necessary. When re-installing, it is very important to ensure the connections are made properly. Please refer to page 21 and 22 for the appropriate assembly instructions.

REFLECTORS

Your bicycle is supplied with one front (white), one rear (red), two wheel (white), and two pedal (orange) reflectors. These are an important safety and legal requirement, and should remain securely fitted and in good, clean conditions at all times. Periodically, inspect all reflectors, brackets and mounting hardware for signs of wear or damage. Replace immediately if damage is found.

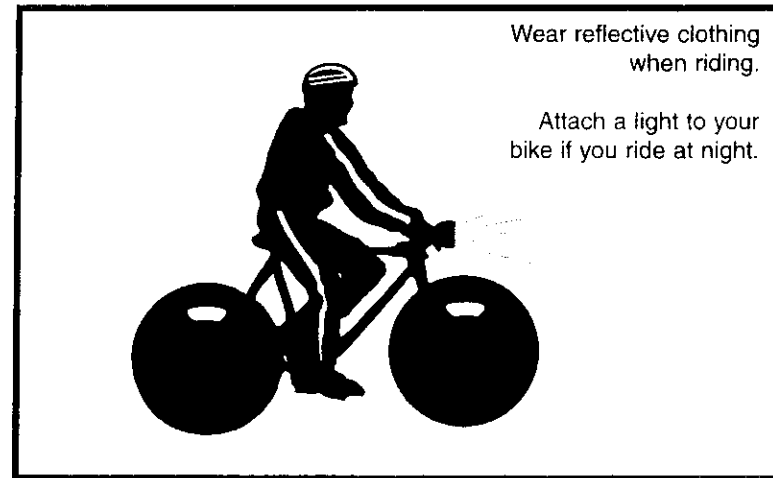
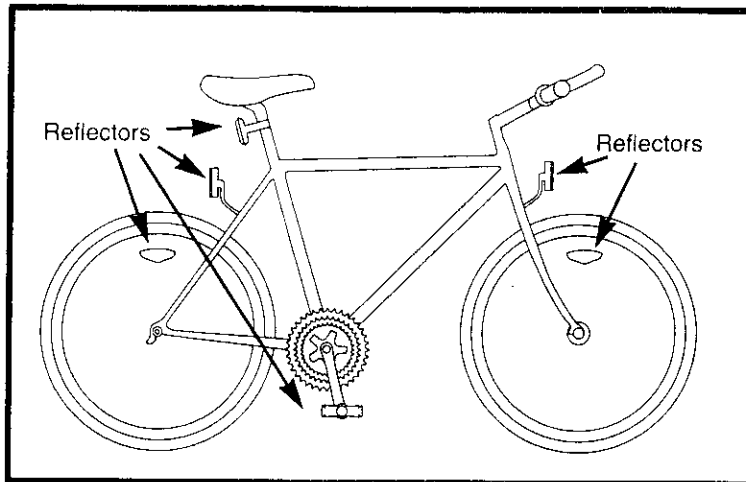

Problem	Possible Cause	Remedy
Gear shifts not working properly	<ul style="list-style-type: none"> - Derailleur cables sticking/stretched/damaged - Front or rear derailleur not adjusted properly - Indexed shifting not adjusted properly 	<ul style="list-style-type: none"> - Lubricate/tighten/replace cables - Adjust derailleurs - Adjust indexing
Slipping chain	<ul style="list-style-type: none"> - Excessively worn/chipped chainring or freewheel sprocket teeth - Chain worn/stretched - Stiff link in chain - Non compatible chain/chainring/freewheel 	<ul style="list-style-type: none"> - Replace chainring, sprockets and chain - Replace chain - Lubricate or replace link - Seek advice at a bicycle shop
Chain jumping off freewheel sprocket or chainring	<ul style="list-style-type: none"> - Chainring out of true - Chainring loose - Chainring teeth bent or broken - Rear or front derailleur side-to-side travel out of adjustment 	<ul style="list-style-type: none"> - Re-true if possible, or replace - Tighten mounting bolts - Repair or replace chainring/set - Adjust derailleur travel
Constant clicking noises when pedaling	<ul style="list-style-type: none"> - Stiff chain link - Loose pedal axle/bearings - Loose bottom bracket axle/bearings - Bent bottom bracket or pedal axle - Loose crankset 	<ul style="list-style-type: none"> - Lubricate chain / Adjust chain link - Adjust bearings/axle nut - Adjust bottom bracket - Replace bottom bracket axle or pedals - Tighten crank bolts
Grinding noise when pedaling	<ul style="list-style-type: none"> - Pedal bearings too tight - Bottom bracket bearings too tight - Chain fouling derailleurs - Derailleur jockey wheels dirty/binding 	<ul style="list-style-type: none"> - Adjust bearings - Adjust bearings - Adjust chain line - Clean and lubricate jockey wheels

Problem	Possible Cause	Remedy
Freewheel does not rotate	<ul style="list-style-type: none"> - Freewheel internal pawl pins are jammed 	<ul style="list-style-type: none"> - Lubricate. If problem persists, replace freewheel
Brakes not working effectively	<ul style="list-style-type: none"> - Brake blocks worn down - Brake blocks/rim greasy, wet or dirty - Brake cables are binding/stretched/damaged - Brake levers are binding - Brakes out of adjustment 	<ul style="list-style-type: none"> - Replace brake blocks - Clean blocks and rim - Clean/adjust/replace cables - Adjust brake levers - Center brakes
When applying the brakes they squeal/squeak	<ul style="list-style-type: none"> - Brake blocks worn down - Brake block toe-in incorrect - Brake blocks/rim dirty or wet - Brake arms loose 	<ul style="list-style-type: none"> - Replace blocks - Correct block toe-in - Clean blocks and rim - Tighten mounting bolts
Knocking or shuddering when applying brakes	<ul style="list-style-type: none"> - Bulge in the rim or rim out of true - Brake mounting bolts loose - Brakes out of adjustment - Fork loose in head tube 	<ul style="list-style-type: none"> - True wheel or take to a bike shop for repair - Tighten bolts - Center brakes and/or adjust brake block toe-in - Tighten headset
Wobbling wheel	<ul style="list-style-type: none"> - Axle broken - Wheel out of true - Hub comes loose - Headset binding - Hub bearings collapsed 	<ul style="list-style-type: none"> - Replace axle - True wheel - Adjust hub bearings - Adjust headset - Replace bearings

Problem	Possible Cause	Remedy
Steering not accurate	<ul style="list-style-type: none"> - Wheels not aligned in frame - Headset loose or binding - Front forks or frame bent 	<ul style="list-style-type: none"> - Align wheels correctly - Adjust/tighten headset - Take bike to a bike shop for possible frame realignment
Frequent punctures	<ul style="list-style-type: none"> - Inner tube old or faulty - Tire tread/casing worn - Tire unsuited to rim - Tire not checked after previous puncture - Tire pressure too low - Spoke protruding into rim 	<ul style="list-style-type: none"> - Replace Inner tube - Replace tire - Replace with correct tire - Remove sharp object embedded in tire - Correct tire pressure - File down spoke



Purchase Record Card

Fill in Immediately and retain as a record of your purchase.

*Please retain your sales receipt for any possible warranty claims.

Your Name: _____

Address: _____

Date Purchased: _____ Place of Purchase: _____

Model Name: _____

Wheel Size: _____

Color: _____

Serial Number: _____

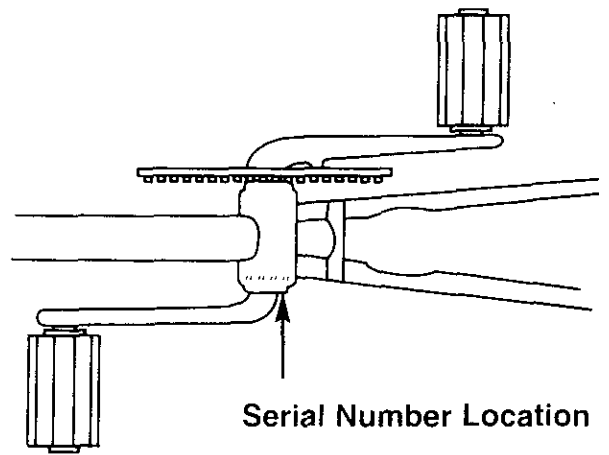

PACIFIC LIMITED WARRANTY
AND POLICY ON REPLACEMENT PROCEDURES AND RESPONSIBILITIES

Your purchase includes the following warranty which is in lieu of all other express warranties. This warranty is extended only to the initial consumer purchaser. No warranty registration is required. This warranty gives you specific legal rights and you may have other rights which vary from state to state.

FRAME

The entire frame is guaranteed against faulty materials and workmanship for as long as the initial consumer purchaser has the bicycle, subject to the condition of the warranty listed below. If frame failure should occur due to faulty materials or workmanship during the guarantee period, the frame will be replaced. For frame replacement under this Pacific Limited Warranty, contact us, stating the nature of the failure, model number, date received and the name of the store from which the bike was received, at the address given on this page. Frame must be returned for inspection at customer's expense. Please note: the fork is not part of the frame.

PARTS

All other parts of the unit except Normal Wear Parts are warranted against defective materials and workmanship for a period of 1 year from the date of purchase by the initial consumer purchaser, subject to the Terms and Conditions of the warranty listed below. If failure of any part should occur during the warranty period, the part will be replaced for you if the failure was due to faulty materials or workmanship. All warranty claims must be submitted to the address below and must be shipped prepaid and accompanied by proof of purchase. Any other warranty claims not included in this statement are void. This especially includes installation, assembly, and disassembly costs. This warranty does not cover paint damage, rust, or any modifications made to the bicycle. Normal Wear Parts are defined as grips, tires, tubes, cables and saddle covering. These parts are warranted to be free from defects in material and workmanship as delivered with the product. Any claim for repair or replacement of Normal Wear Parts (grips, tubes, tires, cables, brake shoes, and saddle covering) and missing parts must be made within thirty (30) days of the date of purchase. The warranty does not cover normal wear and tear, improper assembly or maintenance, or installation of parts or accessories not originally intended or compatible with the bicycle as sold. The warranty does not apply to damage or failure due to accident, abuse, misuse, neglect, or theft. Claims involving these issues will not be honored.

CONDITIONS OF WARRANTY

1. Your bicycle has been designed for general transportation and recreational use, but has not been designed to withstand abuse associated with stunting and jumping. This warranty ceases when you rent, sell, or give away the bicycle, ride with more than one person, or use the bicycle for stunting or jumping.
2. This warranty does not cover ordinary wear and tear or anything you break accidentally or deliberately.
3. It is the responsibility of the individual consumer purchaser to assure that all parts included in the factory-sealed carton are properly installed, all functional parts are initially adjusted properly, and subsequent normal maintenance services and adjustments necessary to keep the bicycle in good operating condition are properly made. This warranty does not apply to damage due to improper installation of parts or failure to properly maintain or adjust the bicycle. NOTICE: Bicycle specifications subject to change without notice.

PACIFIC CYCLE LLC
4902 Hammersley Road
Madison, WI 53711
Call Toll Free 1-800-283-3303
Monday -Friday 8:00 a.m. to 4:30 p.m. Central Time

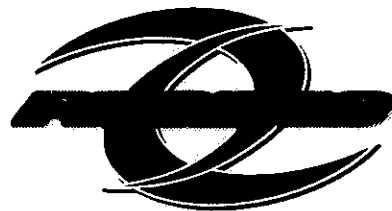

PACIFIC CYCLE LLC

4902 Hammersley Road

Madison, WI 53711

Phone 608/268-2456

Fax 608/268-2455

Customer Service 1-800-283-3303

E-mail: service@pacific-cycle.com

Web Address: www.pacific-cycle.com

© Copyright 2000 Pacific Cycles