

# NordicTrack®

## COMMERCIAL VR25 ELITE

[www.nordictrack.com](http://www.nordictrack.com)

Model No. NTEX89914.0

Serial No. \_\_\_\_\_

Write the serial number in the space above for reference.

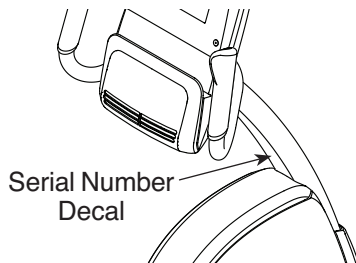

### ACTIVATE YOUR WARRANTY

To register your product and activate your warranty today, go to [www.nordictrackservice.com/registration](http://www.nordictrackservice.com/registration).

### CUSTOMER CARE

For service at any time, go to [www.nordictrackservice.com](http://www.nordictrackservice.com).

Or call 1-800-TO-BE-FIT  
(1-800-862-3348)  
Mon.–Fri. 6 a.m.–6 p.m. MT  
Sat. 8 a.m.–12 p.m. MT

Please do not contact the store.

### ⚠ CAUTION

Read all precautions and instructions in this manual before using this equipment. Keep this manual for future reference.

## USER'S MANUAL

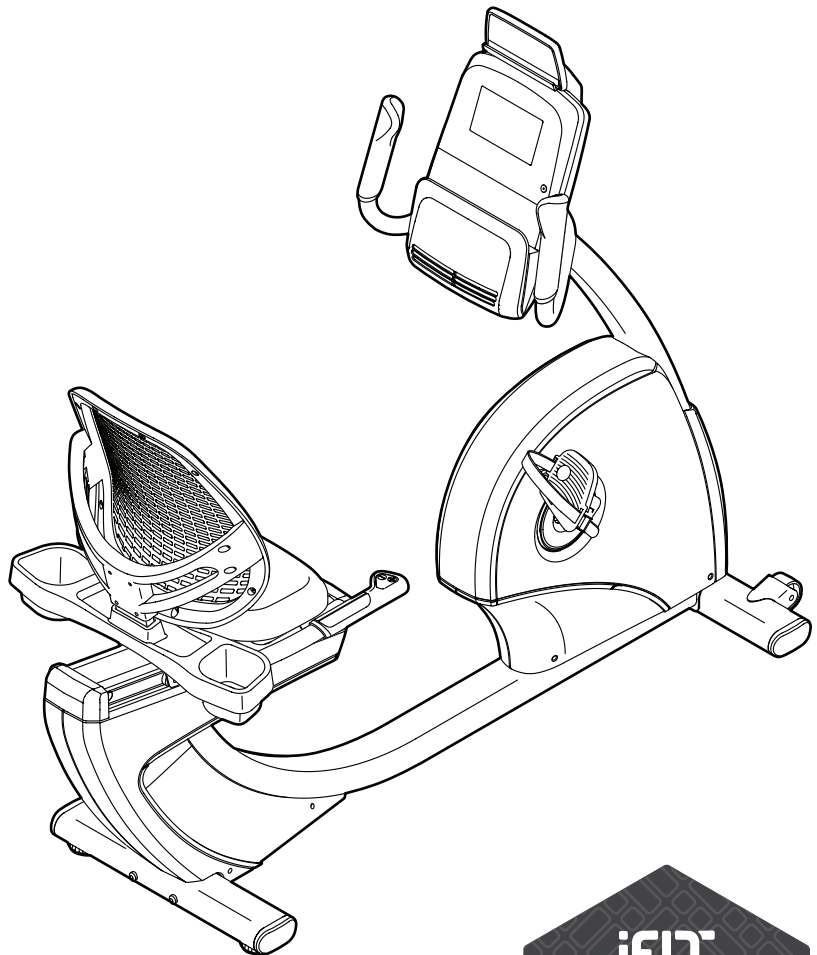

# TABLE OF CONTENTS

WARNING DECAL PLACEMENT .....	2
IMPORTANT PRECAUTIONS .....	3
BEFORE YOU BEGIN .....	6
PART IDENTIFICATION CHART .....	7
ASSEMBLY .....	8
THE CHEST HEART RATE MONITOR .....	16
HOW TO USE THE EXERCISE BIKE .....	17
FCC INFORMATION .....	31
MAINTENANCE AND TROUBLESHOOTING .....	32
EXERCISE GUIDELINES .....	34
PART LIST .....	36
EXPLODED DRAWING .....	38
ORDERING REPLACEMENT PARTS .....	Back Cover
LIMITED WARRANTY .....	Back Cover

## WARNING DECAL PLACEMENT

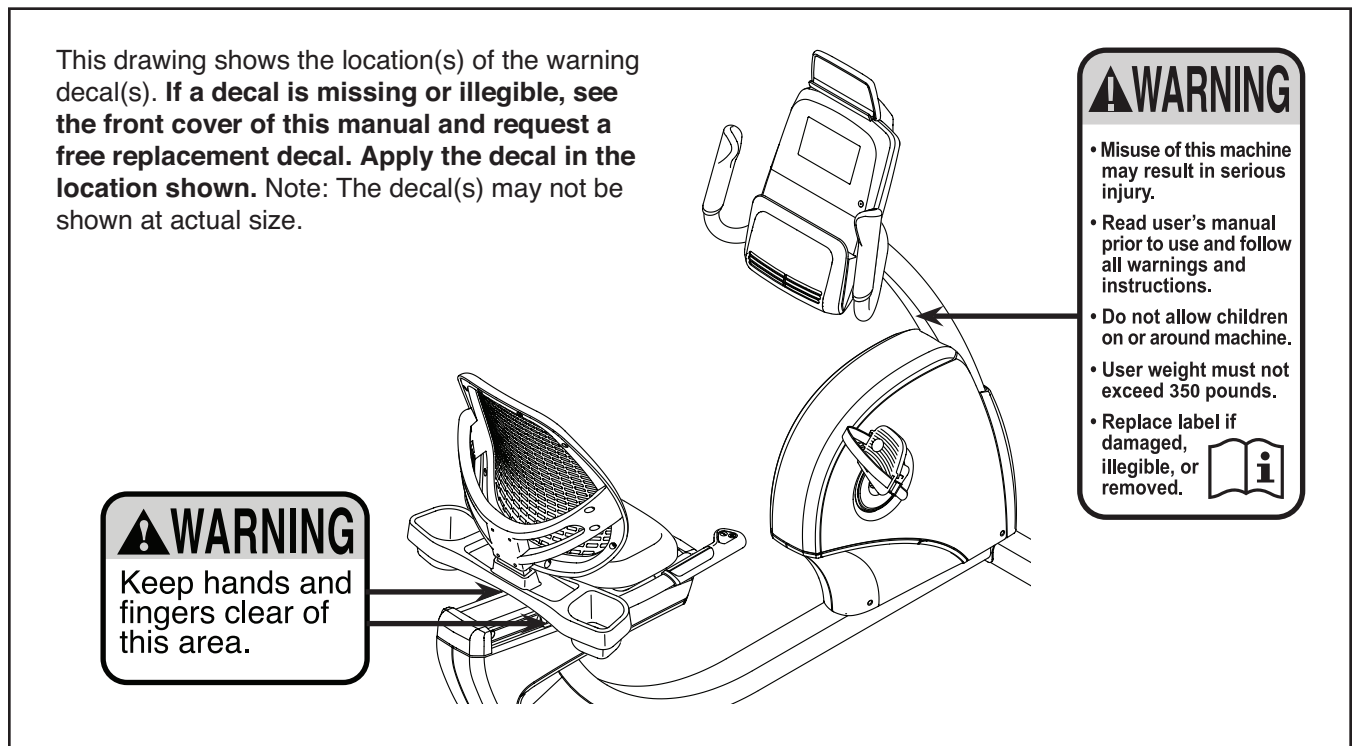

NORDICTRACK is a registered trademark of ICON Health & Fitness, Inc.  
IFIT is a registered trademark of ICON Health & Fitness, Inc. Google Maps is a trademark of Google Inc.  
Wi-Fi is a registered trademark of Wi-Fi Alliance. WPA and WPA2 are trademarks of Wi-Fi Alliance.

---

# IMPORTANT PRECAUTIONS

**⚠️ WARNING:** To reduce the risk of serious injury, read all important precautions and instructions in this manual and all warnings on your exercise bike before using your exercise bike. ICON assumes no responsibility for personal injury or property damage sustained by or through the use of this product.

1. It is the responsibility of the owner to ensure that all users of the exercise bike are adequately informed of all precautions.
2. Before beginning any exercise program, consult your physician. This is especially important for persons over age 35 or persons with pre-existing health problems.
3. Use the exercise bike only as described in this manual.
4. The exercise bike is intended for home use only. Do not use the exercise bike in a commercial, rental, or institutional setting.
5. Keep the exercise bike indoors, away from moisture and dust. Do not put the exercise bike in a garage or covered patio, or near water.
6. Place the exercise bike on a level surface with at least 2 ft. (0.6 m) of clearance around the exercise bike. To protect the floor or carpet from damage, place a mat under the exercise bike.
7. Inspect and properly tighten all parts regularly. Replace any worn parts immediately.
8. Keep children under age 12 and pets away from the exercise bike at all times.
9. Wear appropriate clothes while exercising; do not wear loose clothes that could become caught on the exercise bike. Always wear athletic shoes for foot protection.
10. The exercise bike should not be used by persons weighing more than 350 lbs. (159 kg).
11. Be careful when mounting and dismounting the exercise bike.
12. The heart rate monitor is not a medical device. Various factors, including the user's movement, may affect the accuracy of heart rate readings. The heart rate monitor is intended only as an exercise aid in determining heart rate trends in general.
13. Always keep your back straight while using the exercise bike; do not arch your back.
14. Over exercising may result in serious injury or death. If you feel faint, if you become short of breath, or if you experience pain while exercising, stop immediately and cool down.

# MAKE YOUR FITNESS GOALS A **REALITY**

**iFIT**<sup>®</sup>

Congratulations on the purchase of your new iFit<sup>®</sup> compatible fitness equipment. You're just one click away from making your fitness goals a reality.

**GO TO IFIT.COM TO GET STARTED**

## **DO MORE THAN JUST WORK OUT**

iFit<sup>®</sup> is the most powerful training tool available to help you accomplish all of your fitness goals. From weight loss and performance to personalized training programs, iFit<sup>®</sup> is the key to getting more out of everything you do. Some features require paid subscription.



### **LOSE WEIGHT**

Stay on track and motivated with progressive weight loss programs with our trainers, including Jillian Michaels.



### **COMPETE WITH OTHERS**

Push yourself to new limits with real-time virtual races.



### **PERSONALIZED EVENT TRAINING**

5k, 10k, half or full marathon training will help you prepare for your event.



### **GO MOBILE**

Track your workout anywhere you go with iFit<sup>®</sup> mobile apps.



### **MAP YOUR ROUTE**

With Google Maps<sup>™</sup>, your fitness equipment will simulate the earth's terrain while displaying Street View during your workout.



### **SHARE YOUR PROGRESS**

Inspire others, motivate yourself and share routes, workouts and more.

GO TO  
**IFIT.COM**

OR CALL  
**877-236-1009**

# PROTECT

YOUR FITNESS EQUIPMENT  
WITH AN EXTENDED SERVICE PLAN



Your new fitness equipment is not an ordinary purchase; it is an investment in your health and well being for years to come.

As the leading provider of manufacturer's extended service plans, ICON strives to protect your equipment and your future.

Please review the following service plans and find one that best fits your needs.

## PREVENTIVE MAINTENANCE SERVICE PLANS

Equipment Price	3-Year Plan	5-Year Plan
\$0.00 to \$1000.00	\$199.99	\$289.99
\$1001.00 to \$1500.00	\$259.99	\$379.99
\$1501.00 to \$2500.00	\$339.99	\$489.99
(Bikes/Systems Only) \$0.00 to \$2500.00	\$139.99	NA

Features:

- Includes an annual preventive maintenance and performance check at your convenience
- Unlimited in-home repairs; no shipping required
- Covers parts and labor on all manufacturer's defects, as well as wear and tear on parts
- Up to 5 years of coverage available

## STANDARD SERVICE PLANS

Equipment Price	1-Year Plan	2-Year Plan	3-Year Plan
\$0.00 to \$300.00	\$29.99	\$39.99	\$59.99
\$301.00 to \$1000.00	\$89.99	\$119.99	\$149.99
\$1001.00 to \$2000.00	\$109.99	\$139.99	\$179.99
\$2001.00 to \$3000.00	\$179.99	\$209.99	\$239.99

Features:

- Unlimited in-home repairs; no shipping required
- Covers parts and labor on all manufacturer's defects, as well as wear and tear on parts
- Up to 3 years of coverage available

To protect your fitness equipment today, please  
call Customer Care at **1-800-677-3838.**  
Or, visit us online at **www.utserv.com.**



# BEFORE YOU BEGIN

Thank you for selecting the revolutionary NORDICTRACK® COMMERCIAL VR 25 ELITE exercise bike. Cycling is an effective exercise for increasing cardiovascular fitness, building endurance, and toning the body. The COMMERCIAL VR 25 ELITE exercise bike provides an impressive selection of features designed to make your workouts at home more effective and enjoyable.

**For your benefit, read this manual carefully before you use the exercise bike.** If you have questions after

reading this manual, please see the front cover of this manual. To help us assist you, note the product model number and serial number before contacting us. The model number and the location of the serial number decal are shown on the front cover of this manual.

Before reading further, please familiarize yourself with the parts that are labeled in the drawing below.

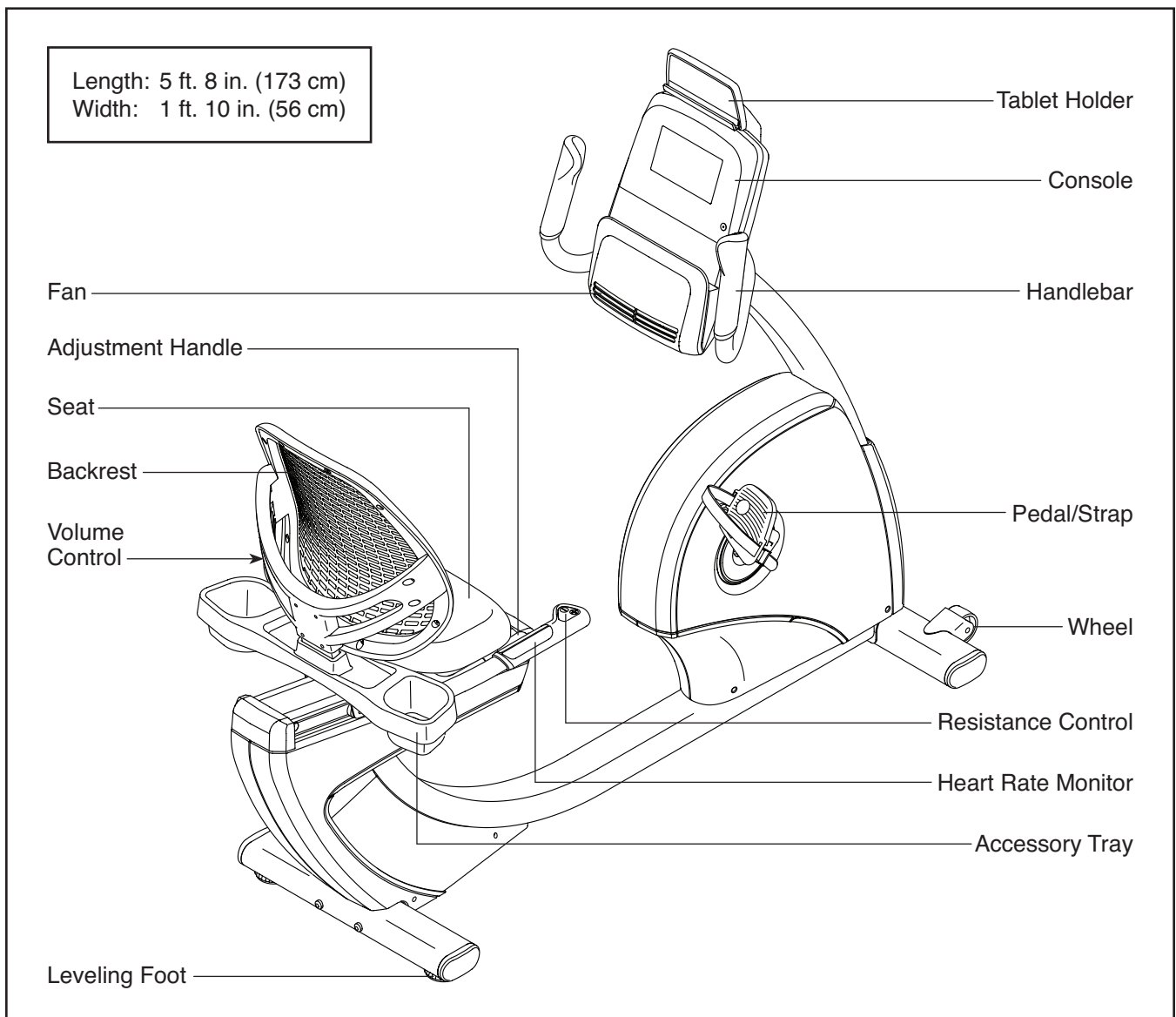

# PART IDENTIFICATION CHART

Use the drawings below to identify the small parts needed for assembly. The number in parentheses below each drawing is the key number of the part, from the PART LIST near the end of this manual. The number following the key number is the quantity needed for assembly. **Note: If a part is not in the hardware kit, check to see if it has been preassembled. Extra parts may be included.**

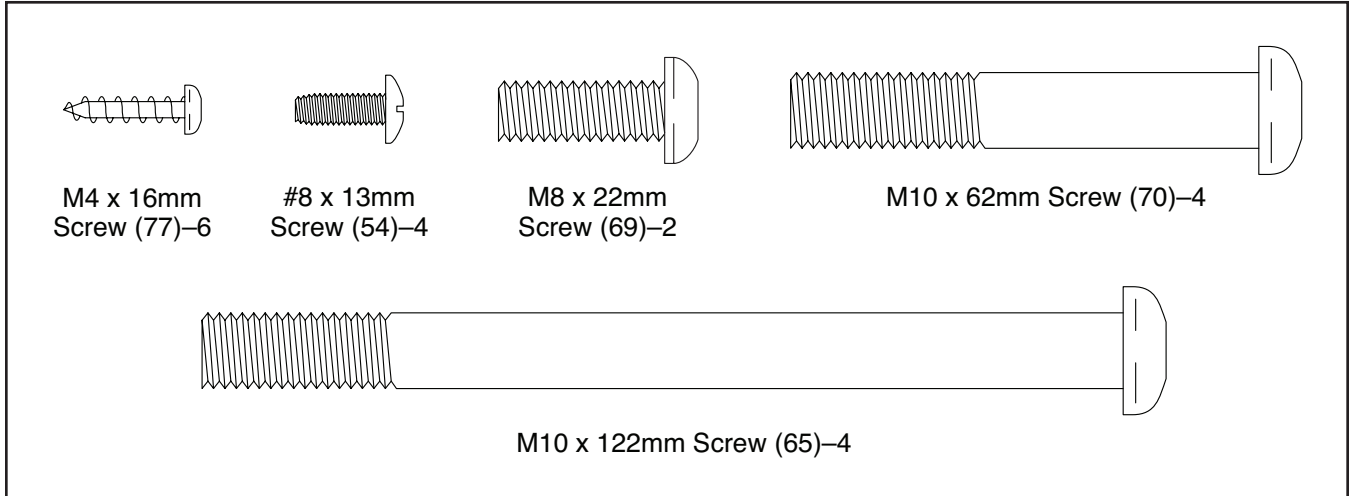

# ASSEMBLY

- Assembly requires two persons.
- Place all parts in a cleared area and remove the packing materials. Do not dispose of the packing materials until you finish all assembly steps.
- Left parts are marked “L” or “Left” and right parts are marked “R” or “Right.”
- To identify small parts, see page 7.

In addition to the included tool(s), assembly requires the following tools:

one Phillips screwdriver 

one adjustable wrench 

Assembly may be easier if you have a set of wrenches. To avoid damaging parts, do not use power tools.

1. **Go to [www.nordictrackservice.com/](http://www.nordictrackservice.com/) registration on your computer and register your product.**

- activates your warranty
- saves you time if you ever need to contact Customer Care
- allows us to notify you of upgrades and offers

Note: If you do not have Internet access, call Customer Care (see the front cover of this manual) and register your product.

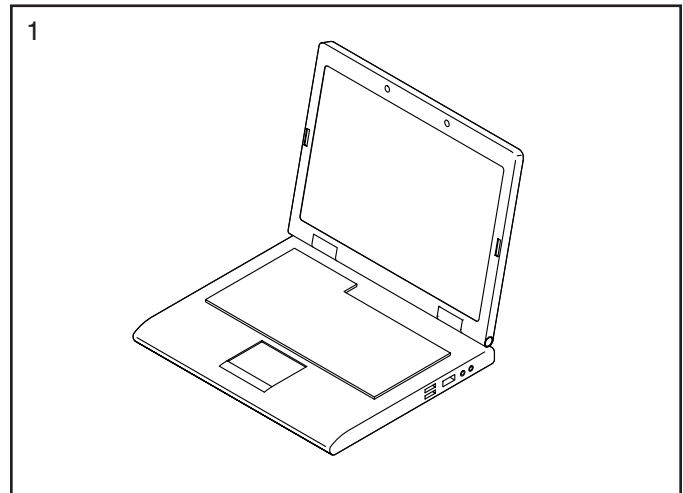

2. Set a sturdy piece of packing material under the rear of the Frame (1). **Have a second person hold the Frame to prevent it from tipping while you complete this step.**

Orient the Rear Stabilizer (16) as indicated by the sticker. Attach the Rear Stabilizer to the Frame (1) with two M10 x 122mm Screws (65).

Then, remove the packing material.

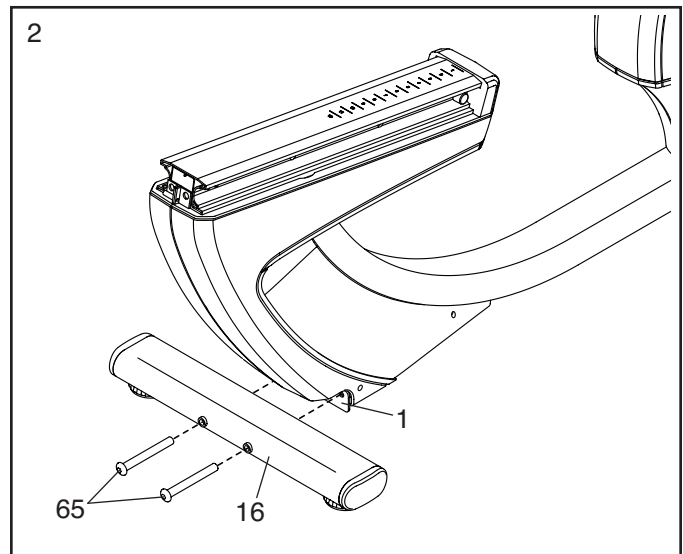



3. Set a sturdy piece of packing material under the front of the Frame (1). **Have a second person hold the Frame to prevent it from tipping while you complete this step.**

Orient the Front Stabilizer (15) as shown. Attach the Front Stabilizer to the Frame (1) with two M10 x 122mm Screws (65).

Then, remove the packing material.

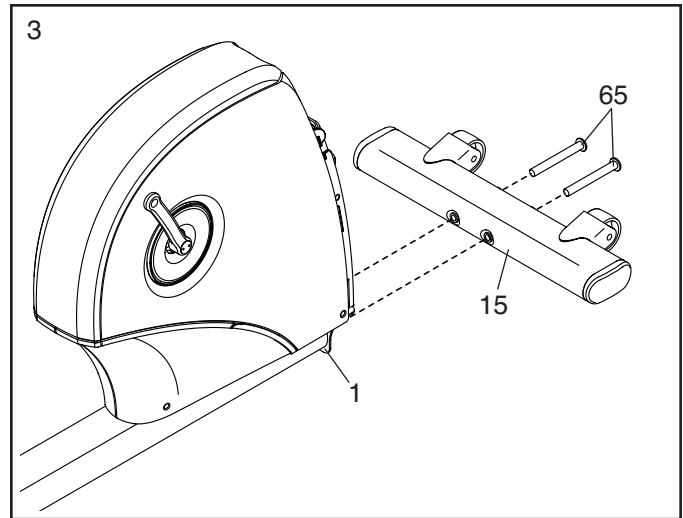

4. Orient the Upright (2) as shown. Have a second person hold the Upright near the front of the Frame (1).

Tie the lower end of the wire tie in the Upright (2) to the Main Wire (43) and to the Frame Pulse Wire (42) in the Frame (1).

Then, pull the upper end of the wire tie until the wires are routed through the Upright (2).

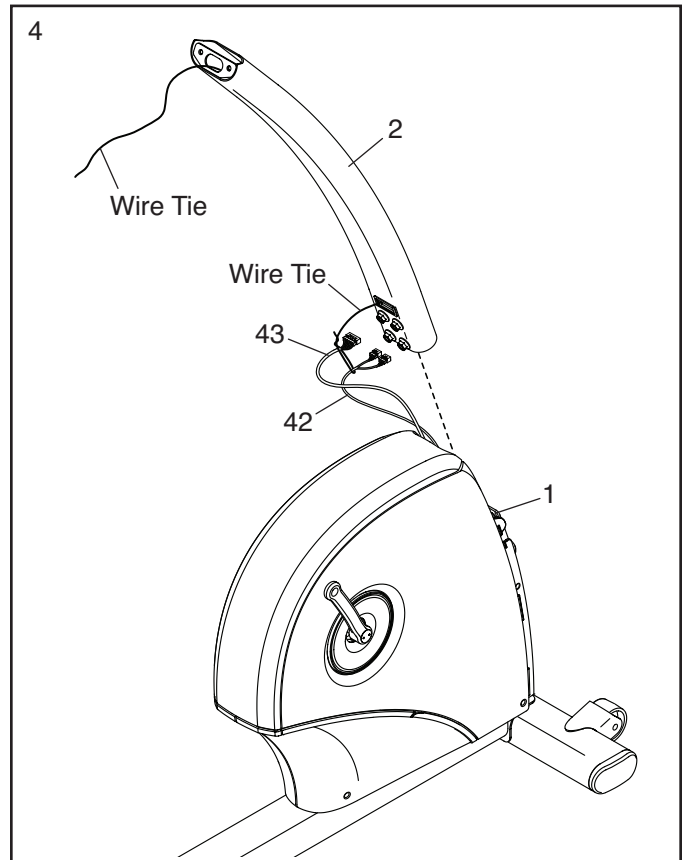

5. **Tip: Avoid pinching the wires.** Slide the Upright (2) onto the Frame (1).

Attach the Upright (2) with four M10 x 62mm Screws (70); **start all the Screws, and then tighten them.**

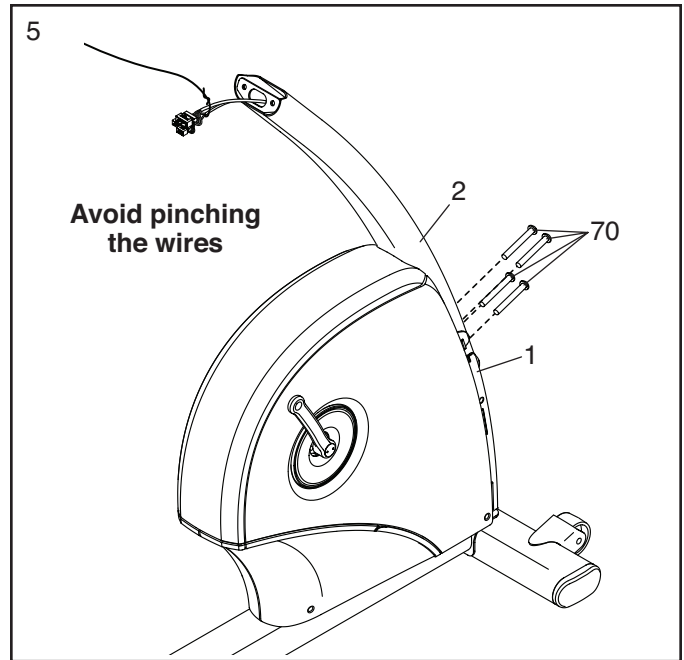

6. Press the mount on the Front Shield (58) into the Frame (1). Then, press the Front Shield into the Left and Right Front Shields (13, 14).

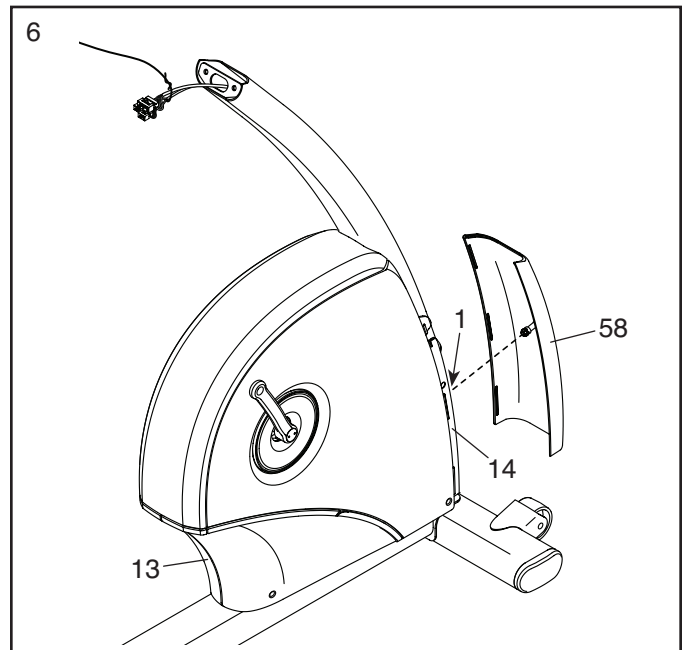

7. Orient the Upright Cover (57) as shown. Hold the Upright Cover near the Upright (2), and insert the wires upward through the Upright Cover.

Then, slide the Upright Cover (57) onto the Upright (2).

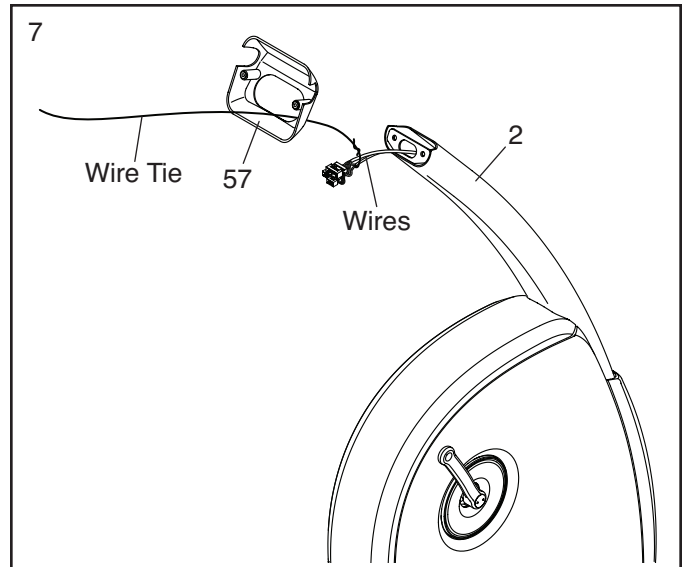

8. Orient the Handlebar (7) as shown. While a second person holds the Handlebar near the Upright (2), insert the wires upward through the Handlebar.

**Tip: Avoid pinching the wires.** Attach the Handlebar (7) to the Upright (2) with two M8 x 22mm Screws (69).

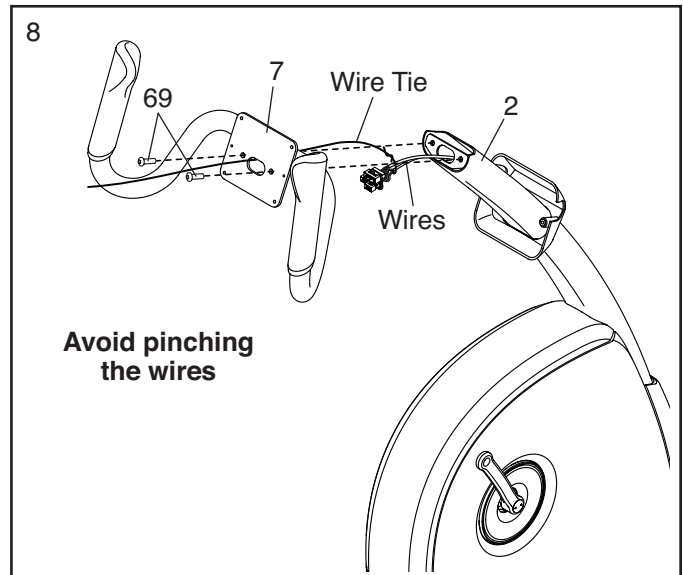

9. Untie and discard the wire tie on the Main Wire (43) and the Frame Pulse Wires (42).

While a second person holds the Console (4) near the Handlebar (7), connect the wires on the Console to the Main Wire (43) and the Frame Pulse Wires (42).

Insert the excess wire into the Handlebar (7).

**Tip: It may be helpful to insert the connectors on the wires one at a time through the hole in the Handlebar.**

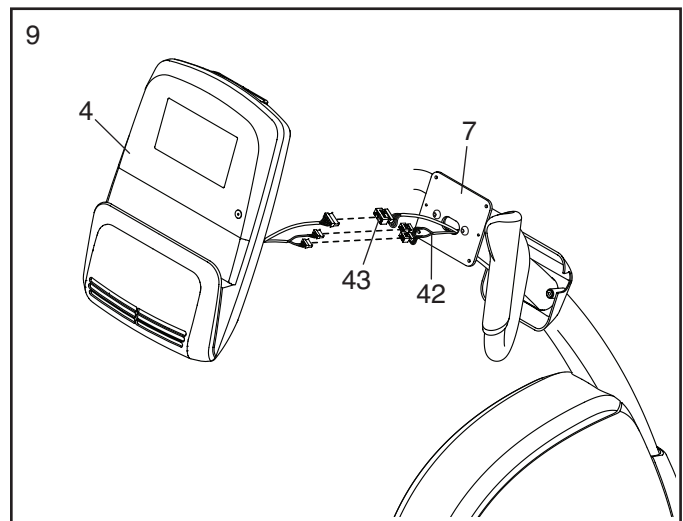

10. **Tip: Avoid pinching the wires.** Attach the Console (4) to the Handlebar (7) with four M4 x 16mm Screws (77); **start all the Screws, and then tighten them.**

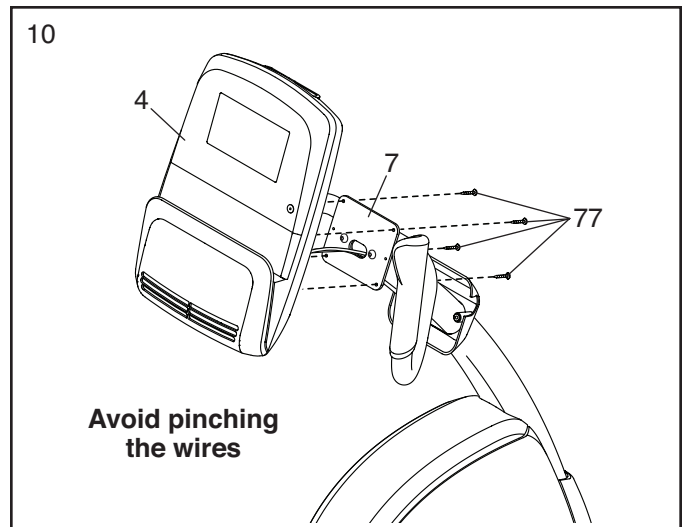

11. Attach the Upright Cover (57) to the Handlebar (7) with two M4 x 16mm Screws (77).

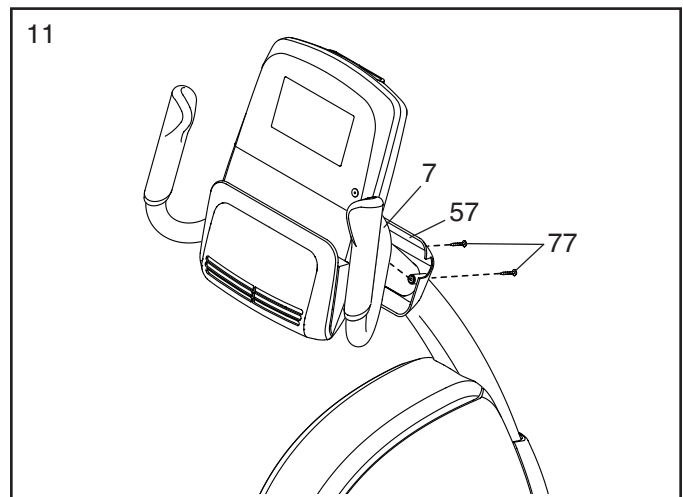

12. **See the inset drawing.** Loosen and remove the Rail Caps (62), and then remove the Rail Rod (60) from the Rail (5). Set these parts aside until step 13.

Orient the seat assembly as shown. Then, slide the Seat Carriage (41) onto the Rail (5).

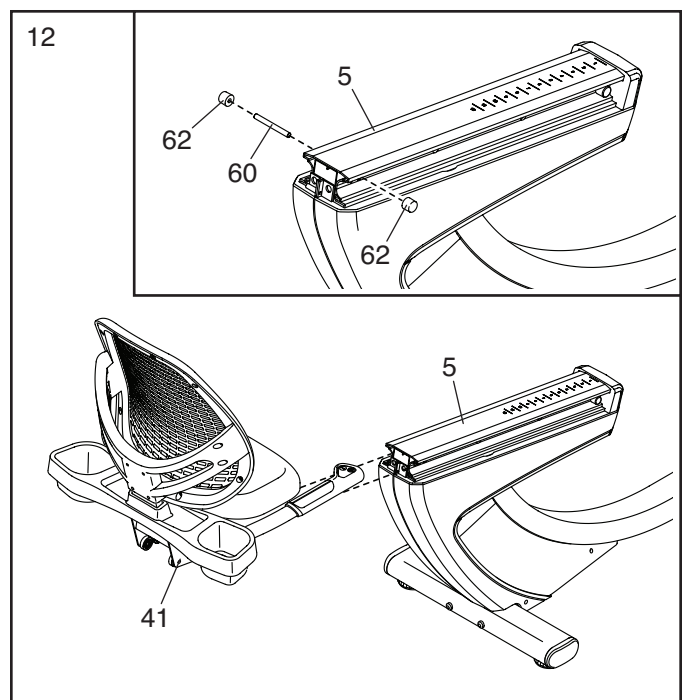

13. Insert the Rail Rod (60) into the Rail (5), and tighten a Rod Cap (62) onto each end of the Rail Rod.

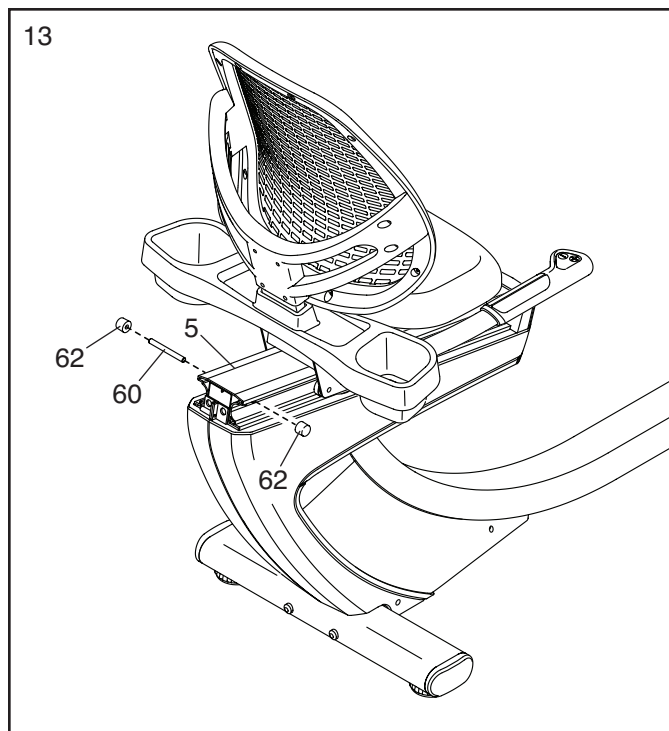

14. Press the mounts on the Rear Rail Cover (90) into the Rail (5).

Then, plug the wire on the seat assembly fully into the Frame Pulse Receptacle (42) on the left side of the exercise bike.

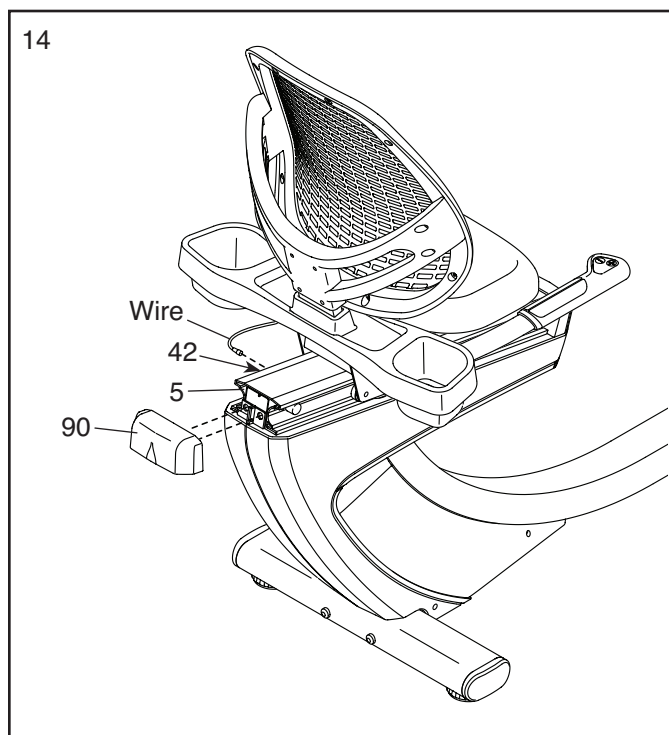

15. Identify the Right Pedal (21).

Using an adjustable wrench, **firmly tighten** the Right Pedal (21) **clockwise** into the Right Crank Arm (23).

**Firmly tighten the Left Pedal (not shown) counterclockwise into the Left Crank Arm (not shown). IMPORTANT: You must turn the Left Pedal counterclockwise to attach it.**

Adjust the strap on the Right Pedal (21) to the desired position, and press the ends of the strap onto the tabs on the Right Pedal. **Adjust the strap on the Left Pedal (not shown) in the same way.**

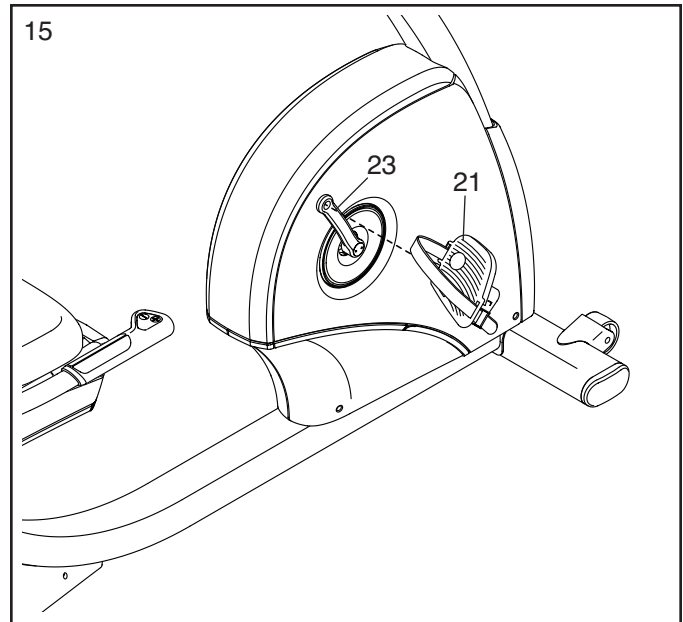

16. Attach the Tablet Holder (53) to the Console (4) with four #8 x 13mm Screws (54); **start all the Screws, and then tighten them.**

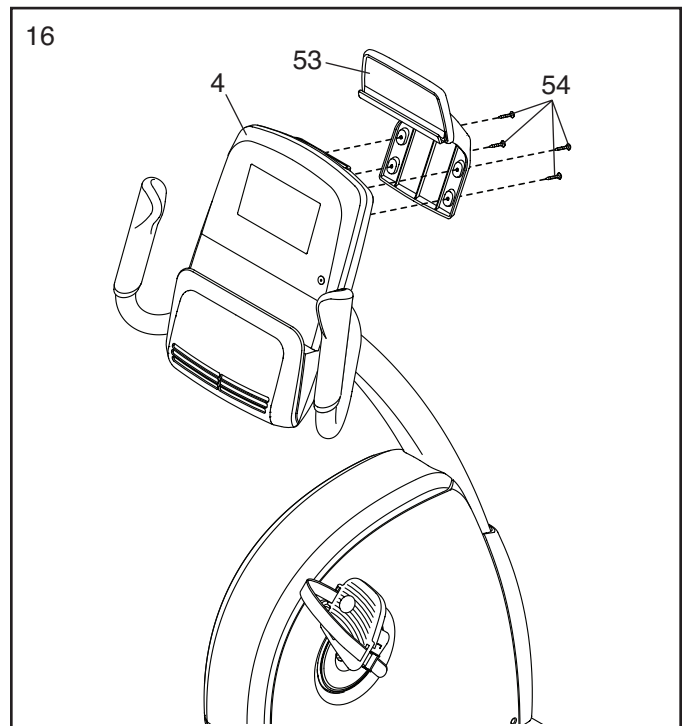

17. **IMPORTANT:** Locate the serial number decal (not shown) in the literature pack included with the exercise bike. Place the serial number decal on the Upright (2) in the indicated location below the general warning decal.

Then, plug the Power Adapter (51) into the receptacle on the frame of the exercise bike.

Note: To plug the Power Adapter (51) into an outlet, see HOW TO PLUG IN THE POWER ADAPTER on page 17.

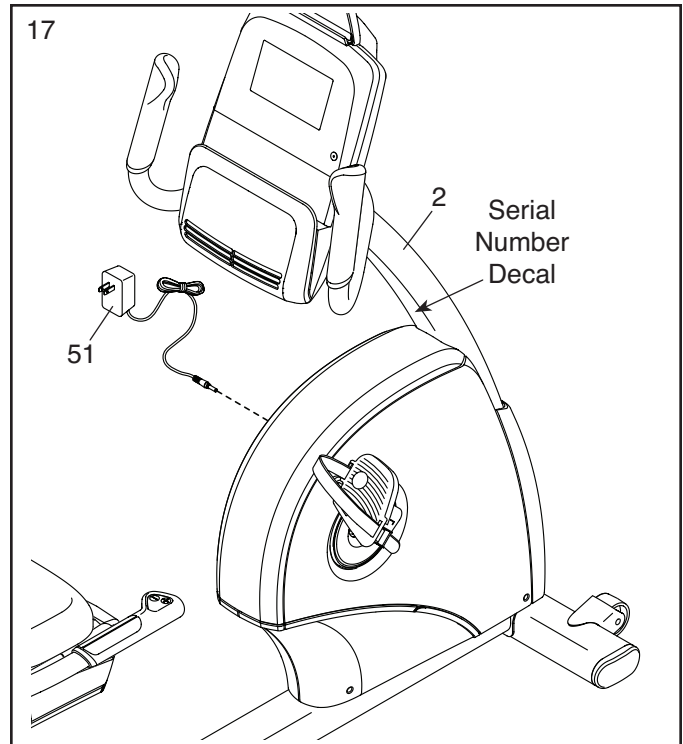

18. **After the exercise bike is assembled, inspect it to make sure that it is assembled correctly and that it functions properly. Make sure that all parts are properly tightened before you use the exercise bike.**  
Note: Extra parts may be included. Place a mat beneath the exercise bike to protect the floor.

# THE CHEST HEART RATE MONITOR

## HOW TO PUT ON THE HEART RATE MONITOR

The heart rate monitor consists of a chest strap and a sensor. Depending on the model, attach the chest strap to the sensor in one of the following ways:

1. Press the snap fasteners on the chest strap onto the posts on the sensor.

2. Insert the tab on one end of the chest strap into the hole in one end of the sensor as shown. Then, press the end of the sensor under the buckle on the chest strap. The tab should be flush with the front of the sensor.

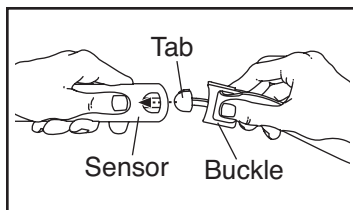

The heart rate monitor must be worn under your clothes, tight against your skin. Wrap the heart rate monitor around your chest in the location shown.

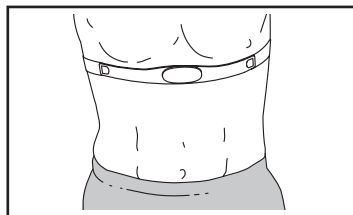

Make sure that the logo is right-side-up. Then, attach the other end of the chest strap. Adjust the length of the chest strap, if necessary.

Pull the sensor away from your body a few inches and locate the two electrode areas, which are covered by shallow ridges. Using saline solution such as saliva or contact lens solution, wet the electrode areas. Then, return the sensor to a position against your chest.

## CARE AND MAINTENANCE

- Thoroughly dry the sensor with a soft towel after each use. Moisture may keep the sensor activated, shortening the life of the battery.
- Store the heart rate monitor in a warm, dry place. Do not store the heart rate monitor in a plastic bag or other container that may trap moisture.

- Do not expose the heart rate monitor to direct sunlight for extended periods of time; do not expose it to temperatures above 122° F (50° C) or below 14° F (-10° C).
- Do not excessively bend or stretch the sensor when using or storing the heart rate monitor.
- To clean the sensor, use a damp cloth and a small amount of mild soap. Then, wipe the sensor with a damp cloth and thoroughly dry it with a soft towel. Never use alcohol, abrasives, or chemicals to clean the sensor. Hand wash and air dry the chest strap.

## TROUBLESHOOTING

If the heart rate monitor does not function properly, try the steps below.

- Make sure that you are wearing the heart rate monitor as described at the left. If the heart rate monitor does not function when positioned as described, move it slightly lower or higher on your chest.
- If heart rate readings are not displayed until you begin perspiring, rewet the electrode areas.
- For the console to display heart rate readings, you must be within arm's length of the console.
- If there is a battery cover on the back of the sensor, replace the battery with a new battery of the same type.
- The heart rate monitor is designed to work with people who have normal heart rhythms. Heart rate reading problems may be caused by medical conditions such as premature ventricular contractions (pvc's), tachycardia bursts, and arrhythmia.
- The operation of the heart rate monitor can be affected by magnetic interference from high power lines or other sources. If you suspect that magnetic interference is causing a problem, try relocating the fitness equipment.



# HOW TO USE THE EXERCISE BIKE

## HOW TO PLUG IN THE POWER ADAPTER

**IMPORTANT:** If the exercise bike has been exposed to cold temperatures, allow it to warm to room temperature before you plug in the power adapter. If you do not do this, you may damage the console displays or other electronic components.

Plug the power adapter into the receptacle on the frame of the exercise bike. Then, plug the power adapter into an appropriate outlet that is properly installed in accordance with all local codes and ordinances.

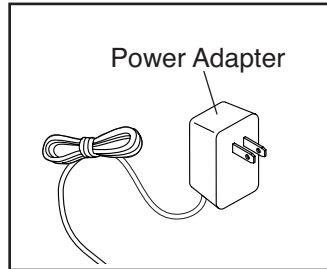

## HOW TO ADJUST THE SEAT

To adjust the seat, push downward on the seat handle, slide the seat forward or backward to the desired position, and then pull upward on the seat handle to lock the seat in place.

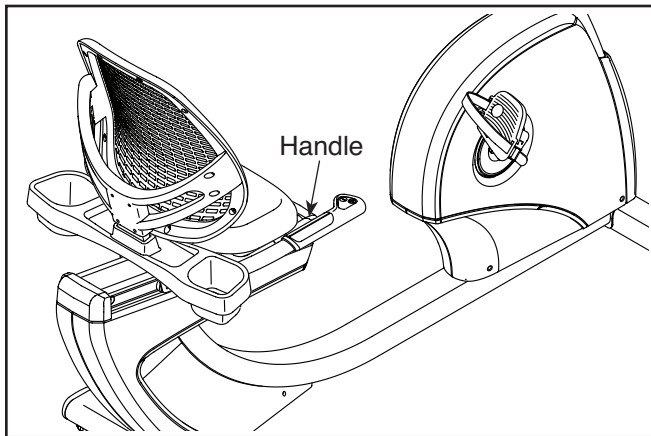

## HOW TO ADJUST THE PEDAL STRAPS

To adjust the pedal straps, first pull the ends of the straps off the tabs on the pedals. Adjust the straps to the desired position, and then press the ends of the straps onto the tabs.

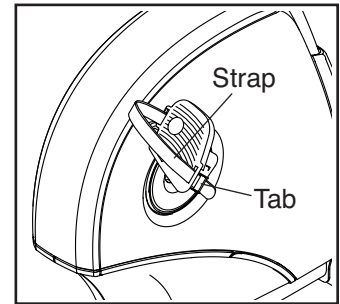

## HOW TO LEVEL THE EXERCISE BIKE

If the exercise bike rocks slightly on your floor during use, turn one or both of the leveling feet beneath the rear stabilizer until the rocking motion is eliminated.

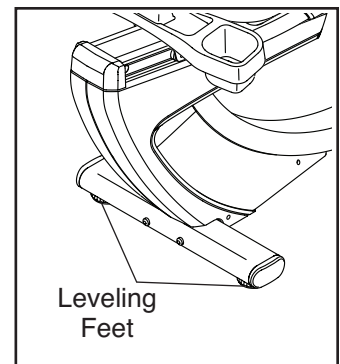

## HOW TO USE THE TABLET HOLDER

**IMPORTANT:** The tablet holder was designed for use with most full-size tablets. Do not place any other electronic device or object into the tablet holder.

To insert a tablet into the tablet holder, set the bottom edge of the tablet in the tray. **Make sure that the tablet is firmly secured in the tablet holder.** Reverse these actions to remove the tablet from the tablet holder.

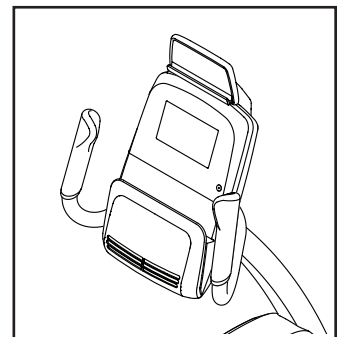

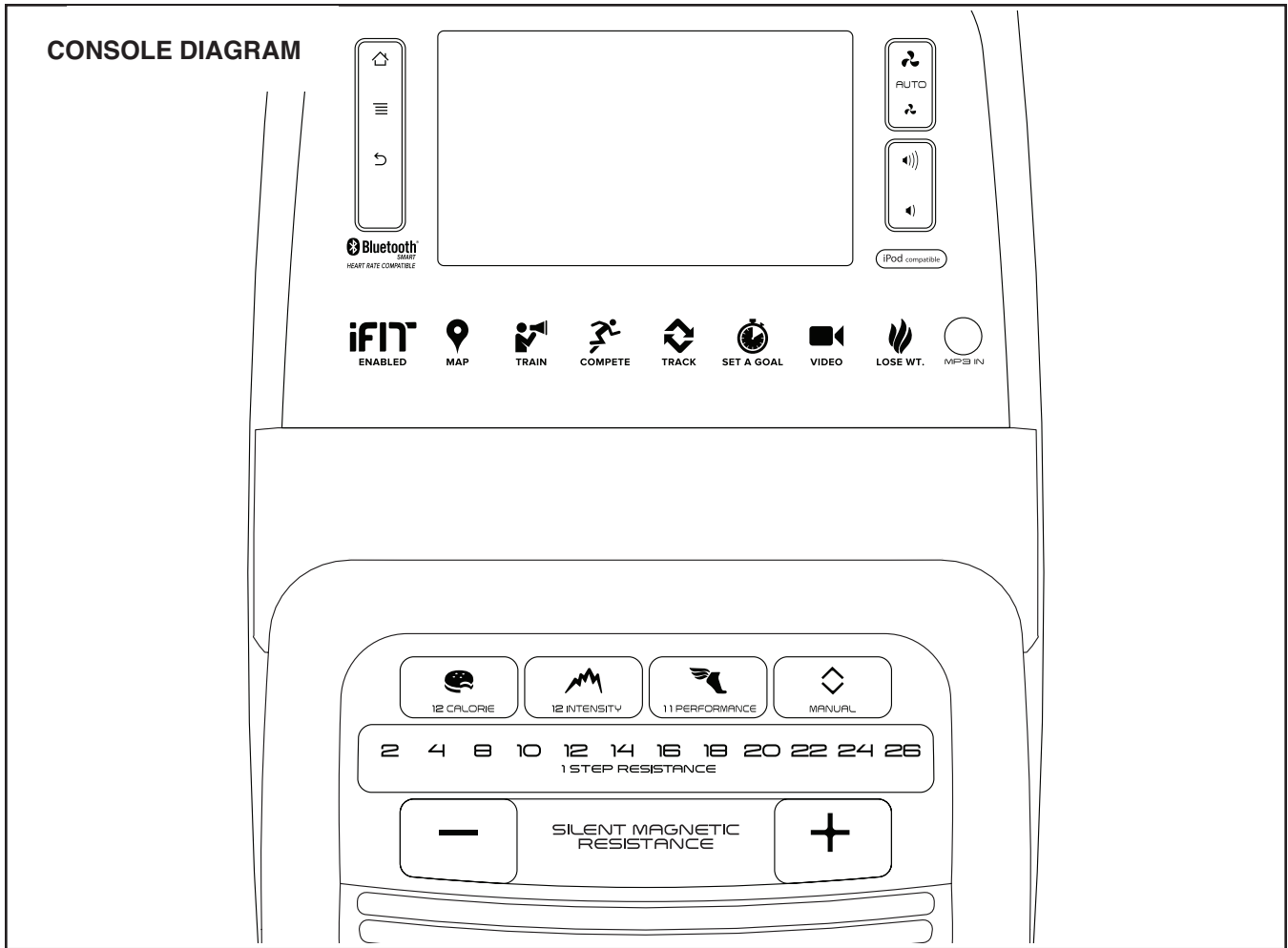

**MAKE YOUR FITNESS GOALS A REALITY WITH IFIT.COM**

With your new iFit-compatible fitness equipment, you can use an array of features on iFit.com to make your fitness goals a reality:



Exercise anywhere in the world with customizable Google Maps.



Download training workouts designed to help you reach your personal goals.



Measure your progress by competing against other users in the iFit community.



Upload your workout results to the iFit cloud and track your accomplishments.



Set calorie, time, or distance goals for your workouts.



Watch high-definition videos with simulated workouts.



Choose and download sets of weight-loss workouts.

**Go to [iFit.com](http://iFit.com) to learn more.**

## FEATURES OF THE CONSOLE

The advanced console offers an array of features designed to make your workouts more effective and enjoyable.

The console features revolutionary iFit technology that enables the console to communicate with your wireless network. With iFit technology, you can download personalized workouts, create your own workouts, track your workout results, and access many other features. **See [www.iFit.com](http://www.iFit.com) for complete information.**

In addition, the console features a selection of onboard workouts and several iFit demo workouts. Each workout automatically controls the resistance of the pedals and prompts you to vary your pedaling speed as it guides you through an effective exercise session. You can also set a customized workout goal with the set-a-goal workout.

When you use the manual mode of the console, you can change the resistance of the pedals with the touch of a button.

While you exercise, the console will display continuous exercise feedback. You can also measure your heart rate using the handgrip heart rate monitor or the chest heart rate monitor.

You can browse the Internet or listen to your favorite workout music or audio books with the console sound system while you exercise.

**To activate the console**, see this page. **To turn off the console**, see this page. **To learn how to use the touch screen**, see page 20. **To set up the console**, see page 20.

## HOW TO ACTIVATE THE CONSOLE

The included power adapter must be used to operate the exercise bike. See **HOW TO PLUG IN THE POWER ADAPTER** on page 17. When the power adapter is plugged in, the display will turn on and the console will be ready for use.

## HOW TO TURN OFF THE CONSOLE

If the pedals do not move for several seconds, the console will pause.

If the pedals do not move for several minutes and the buttons are not pressed, the console will turn off and the display will be reset.

When you are finished exercising, unplug the power adapter. **IMPORTANT: If you do not do this, the electrical components on the exercise bike may wear prematurely.**

Note: The console features a display demo mode, designed to be used if the exercise bike is displayed in a store. When the demo mode is turned on, the console will show a preset presentation. To turn off the demo mode, see step 7 on page 26.

## HOW TO USE THE TOUCH SCREEN

The console features a tablet with a full-color touch screen. The following information will help you become familiar with the tablet's advanced technology:

- The console functions similarly to other tablets. You can slide or flick your finger against the screen to move certain images on the screen, such as the displays in a workout. However, you cannot zoom in and out by sliding your fingers on the screen.
- To type information into a text box, first touch the text box to view the keyboard. To use numbers or other characters on the keyboard, touch the ?123 button. To view more characters, touch the Alt button. Touch the Alt button again to return to the number keyboard. To return to the letter keyboard, touch the ABC button. To use a capital character, touch the button with an upward-facing arrow. To use multiple capital characters, touch the arrow button again. To return to the lowercase keyboard, touch the arrow button a third time. To clear the last character, touch the button with a backward-facing arrow and an X.
- Use these buttons on the console to navigate the tablet. Press the home button to return to the main menu. Press the center button to access the settings menu (see page 26). Press the back button to return to the previous screen.
- If it is difficult for you to touch the correct buttons on the screen, the screen may not be properly calibrated. To calibrate the screen, see step 4 on page 28.

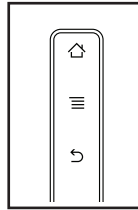

## HOW TO SET UP THE CONSOLE

Before using the exercise bike for the first time, set up the console.

### 1. Connect to your wireless network.

Note: In order to access the Internet, download iFit workouts, and use some other features of the console, you must be connected to a wireless network. See HOW TO USE THE WIRELESS NETWORK MODE on page 29 to connect the console to your wireless network.

### 2. Check for firmware updates.

First, see step 1 on page 26 and step 2 on page 28 and select the maintenance mode. Then, see step 3 on page 28 and check for firmware updates.

### 3. Create an iFit account.

Touch the globe button at the bottom of the screen and then touch the iFit button.

Note: For information about navigating in the Internet browser, see page 30.

The Internet browser will open to the iFit.com home page. Follow the prompts on the website to sign up for your iFit membership. If you have an activation code, select the code activation option.

The console is now ready for you to begin working out. The following pages explain the various workouts and other features that the console offers.

**To use the manual mode**, see page 21. **To use an onboard workout**, see page 22. **To use a set-a-goal workout**, see page 24. **To use an iFit workout**, see page 25.

**To use the equipment settings mode**, see page 26. **To use the maintenance mode**, see page 28. **To use the wireless network mode**, see page 29. **To use the sound system**, see page 30. **To use the Internet browser**, see page 30.

Note: If there is a sheet of plastic on the screen, remove the plastic.

Note: The console can display speed and distance in either miles or kilometers. To find which unit of measurement is selected, see step 15 on page 27. For simplicity, all instructions in this section refer to miles.

## HOW TO USE THE MANUAL MODE

1. **Touch the screen, press any button on the console, or begin pedaling to turn on the console.**

See HOW TO ACTIVATE THE CONSOLE on page 19.

2. **Select the main menu.**

When you turn on the console, the main menu will appear on the screen after the console boots up.

Touch the home button at the bottom of the screen or press the Manual button to return to the main menu at any time.

3. **Change the resistance of the pedals as desired.**

As you pedal, you can change the resistance of the pedals.

To change the resistance, press one of the numbered 1 Step Resistance buttons or press the Silent Magnetic Resistance increase and decrease buttons on the console.

You can also press the Resistance increase and decrease buttons on the right seat handlebar.

Note: After you press a button, it will take a moment for the pedals to reach the selected resistance level.

4. **Follow your progress.**

The console offers several display modes. The display mode that you select will determine which workout information is shown.

To select the desired display mode, simply flick or slide the screen. You can also view additional workout information by touching the red boxes on the screen.

If desired, keep your pedaling speed near the target cadence. The target zone meter will prompt you to increase, decrease, or maintain your pedaling speed. To view the target zone meter, flick or slide the screen. Note: The target cadence is displayed in revolutions per minute (rpm).

If desired, adjust the volume level by pressing the volume increase and decrease buttons on the console.

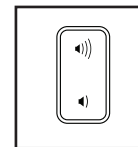

You can also press the Volume increase and decrease buttons on the left seat handlebar.

To pause the workout, touch one of the menu buttons on the screen. To continue the workout, touch the Resume button. To end the workout session, touch the End Workout button.

5. **Measure your heart rate if desired.**

To use the chest heart rate monitor, see page 16. To use the handgrip heart rate monitor, follow the instructions below. **IMPORTANT: If you use both heart rate monitors at the same time, the console will not display your heart rate accurately.**

**If there are sheets of plastic on the metal contacts on the handgrip heart rate monitor, remove the plastic.** To

measure your heart rate, hold the handgrip heart rate monitor with your palms resting against the contacts. **Avoid moving your hands or gripping the contacts tightly.**

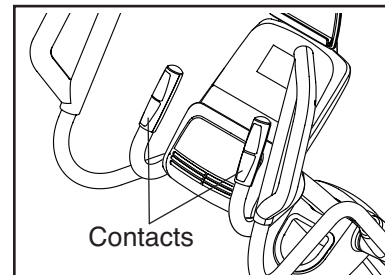

**When your pulse is detected, your heart rate will be shown. For the most accurate heart rate reading, hold the contacts for at least 15 seconds.**

If the display does not show your heart rate, make sure that your hands are positioned as described. Be careful not to move your hands excessively or to squeeze the contacts tightly. For optimal performance, clean the contacts using a soft cloth; **never use alcohol, abrasives, or chemicals to clean the contacts.**

#### **6. Turn on the fan if desired.**

The fan has several speed settings, including an auto mode. While the auto mode is selected, the speed of the fan will automatically increase or decrease as your exercise intensity increases or decreases. Press the fan increase and decrease buttons repeatedly to select a fan speed or to turn off the fan.

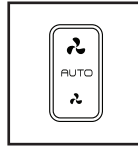

Note: If the pedals are not moved for a while when the main menu is selected, the fan will turn off automatically.

#### **7. When you are finished exercising, the console will turn off automatically.**

See HOW TO TURN OFF THE CONSOLE on page 19.

## **HOW TO USE AN ONBOARD WORKOUT**

### **1. Touch the screen, press any button on the console, or begin pedaling to turn on the console.**

See HOW TO ACTIVATE THE CONSOLE on page 19.

### **2. Select the main menu.**

See step 2 on page 22.

### **3. Select an onboard workout.**

To select an onboard workout, touch the runner button at the bottom of the screen. The workouts menu will appear on the screen.

Select the desired workout category from the workouts menu and then select the desired workout. Note: It may be necessary to scroll the screen to view all the menu options.

Note: You can also press the Calorie, Intensity, or the Performance button on the console.

The screen will show the name and duration of the workout. The screen will also show the approximate number of calories you will burn during the workout and a profile of the resistance settings of the workout.

### **4. Start the workout.**

Touch the Start Workout button to start the workout.

Each workout is divided into segments. One resistance level and one target cadence (speed) are programmed for each segment.

During the workout, the profiles will show your progress. To view the profiles, flick or slide the screen.

During some workouts, the screen will show a map of the route and a marker indicating your progress. Touch the buttons on the screen to select the desired map options.

As you exercise, keep your pedaling speed near the target cadence for the current segment. The target zone meter will prompt you to increase, decrease, or maintain your pedaling speed. To view the target zone meter, flick or slide the screen. Note: The target cadence is displayed in revolutions per minute (rpm).

**IMPORTANT: The target cadence is intended only to provide motivation. Your actual pedaling speed may be slower than the target cadence. Make sure to pedal at a speed that is comfortable for you.**

If the resistance level for the current segment is too high or too low, you can manually override the setting by pressing the Resistance buttons. **If you press a Resistance button**, you can then manually control the resistance (see step 3 on page 21). **To return to the programmed resistance settings of the workout**, touch the Follow Workout button.

**Note: The calorie goal is an estimate of the number of calories that you will burn during the workout. The actual number of calories that you burn will depend on various factors, such as your weight. In addition, if you manually change the resistance during the workout, the number of calories you burn will be affected.**

To pause the workout, touch either the back button or the home button at the bottom of the screen. To continue the workout, touch the Resume button. To end the workout, touch the End Workout button.

The workout will continue in this way until the last segment ends. A workout summary will appear on the screen. After you view the workout summary, touch the Finish button to return to the main menu. You may also be able to either save or publish your results using one of the options on the screen.

**5. Follow your progress.**

See step 4 on page 21.

**6. Measure your heart rate if desired.**

See step 5 on page 21.

**7. Turn on the fan if desired.**

See step 6 on page 22.

**8. When you are finished exercising, the console will turn off automatically.**

See HOW TO TURN OFF THE CONSOLE on page 19.

## HOW TO USE A SET-A-GOAL WORKOUT

1. **Touch the screen, press any button on the console, or begin pedaling to turn on the console.**

See HOW TO ACTIVATE THE CONSOLE on page 19.

2. **Select the main menu.**

See step 2 on page 21.

3. **Select a set-a-goal workout.**

To select a set-a-goal workout, touch the Set A Goal button on the screen or press the Set A Goal button on the console.

To set a customized goal for your workout, touch the button for the desired goal. Then, touch the increase and decrease buttons on the screen to enter your goal and to select other variables for the workout. The screen will show the duration and distance of the workout, and the approximate number of calories you will burn during the workout.

4. **Start the workout.**

Touch the Start button to start the workout.

The workout will function in the same way as the manual mode (see page 21).

As you exercise, keep your pedaling speed near the target cadence for the current segment. The target zone meter will prompt you to increase, decrease, or maintain your pedaling speed. To view the target zone meter, flick or slide the screen. Note: The target cadence is displayed in revolutions per minute (rpm).

**IMPORTANT: The target cadence is intended only to provide motivation. Your actual pedaling speed may be slower than the target cadence. Make sure to pedal at a speed that is comfortable for you.**

If the resistance level for the current segment is too high or too low, you can manually override the setting by pressing the Resistance buttons. **If you press a Resistance button**, you can then manually control the resistance (see step 3 on page 21). **To return to the programmed resistance settings of the workout**, touch the Follow Workout button.

Note: If you manually change the resistance level during a calorie goal workout, the length of the workout will adjust automatically to ensure that you meet your calorie goal.

**Note: The calorie goal is an estimate of the number of calories that you will burn during the workout. The actual number of calories that you burn will depend on various factors, such as your weight. In addition, if you manually change the resistance during the workout, the number of calories you burn will be affected.**

The workout will continue until you reach the goal that you set. A workout summary will appear on the screen. After you view the workout summary, touch the Finish button to return to the main menu. You may also be able to either save or publish your results using one of the options on the screen.

5. **Follow your progress.**

See step 4 on page 21.

6. **Measure your heart rate if desired.**

See step 5 on page 21.

7. **Turn on the fan if desired.**

See step 6 on page 22.

8. **When you are finished exercising, the console will turn off automatically.**

See HOW TO TURN OFF THE CONSOLE on page 19.



## HOW TO USE AN iFIT WORKOUT

Note: To use an iFit workout, you must have access to a wireless network (see HOW TO USE THE WIRELESS NETWORK MODE on page 29). An iFit account is also required.

### 1. Touch the screen, press any button on the console, or begin pedaling to turn on the console.

See HOW TO ACTIVATE THE CONSOLE on page 19.

### 2. Select the main menu.

See step 2 on page 21.

### 3. Log in to your iFit account.

If you have not already done so, touch the Login button at the bottom of the screen to log in to your iFit account. The screen will ask for your iFit.com username and password. Enter them and touch the Login button. Touch the Cancel button to exit the login screen.

To switch users within your iFit account, touch the user button at the bottom of the screen. If more than one user is associated with the account, a list of users will appear. Touch the name of the desired user.

### 4. Select an iFit workout.

To download an iFit workout in your schedule, touch the Map, Train, Video, or Lose Wt. button to download the next workout of that type in your schedule. Note: You may be able to access demo workouts through these options, even if you do not log in to an iFit account.

To compete in a race that you have previously scheduled, touch the Compete button. To view your Workout History, touch the Track button. To use a set-a-goal workout, touch the Set A Goal button (see page 24). Note: You can also press one of the iFit buttons on the console.

Before some workouts will download, you must add them to your schedule on iFit.com.

**For more information about the iFit workouts, please see [www.iFit.com](http://www.iFit.com).**

When you select an iFit workout, the screen will show the name of the workout and the estimated duration of the workout based on your pedaling cadence. The screen will also show the approximate number of calories you will burn during the workout.

If you select a competition workout, the display will count down to the beginning of the race.

### 5. Start the workout.

See step 4 on page 22.

During some workouts, an audio coach will guide you through your workout.

### 6. Follow your progress.

See step 4 on page 21. The screen may also show a map of the route and a marker indicating your progress. Touch the buttons on the screen to select the desired map options.

During a competition workout, the screen will show your position in the race relative to other racers.

### 7. Measure your heart rate if desired.

See step 5 on page 21.

### 8. Turn on the fan if desired.

See step 6 on page 22.

### 9. When you are finished exercising, the console will turn off automatically.

See HOW TO TURN OFF THE CONSOLE on page 19.

**For more information about iFit features, go to [www.iFit.com](http://www.iFit.com).**

## HOW TO USE THE EQUIPMENT SETTINGS MODE

**IMPORTANT:** Some of the features described may not be enabled. Occasionally, a firmware update may add new features or cause your console to function slightly differently.

### 1. Select the settings main menu.

Turn on the console and select the main menu (see steps 1 and 2 on page 26). Then, touch the gears button at the bottom of the screen to select the settings main menu.

Note: You can also press the center (settings) button on the console to select the settings main menu.

### 2. Select the equipment settings mode.

In the settings main menu, touch the Equipment Settings button.

Note: It may be necessary to scroll the screen to view all the menu options.

### 3. Enable or disable the auto relogin feature.

Enable this feature to have the console automatically log in to your iFit account when you plug in the power adapter. Note: This feature is recommended for private owners of the exercise bike only.

To enable or disable the auto relogin feature, first touch the Auto Relogin button. Next, touch the Enable checkbox or the Disable checkbox. Then, touch the back button on the screen.

### 4. Enable or disable automatic console updates.

To enable or disable automatic console updates, first touch the Auto Update button. Next, touch the Enable checkbox or the Disable checkbox. Then, touch the back button on the screen.

Note: To select a time for automatic console updates, see step 14.

### 5. Enable or disable the Internet browser.

To enable or disable the Internet browser, first touch the Browser button. Next, touch the Enable checkbox or the Disable checkbox. Then, touch the back button on the screen.

### 6. Select a time for the cadence timeout.

The console features a cadence timeout feature; if no buttons are touched or pressed and the pedals do not move for a set amount of time, the console will prompt you to resume or end the workout.

To select the amount of time the console will wait before it prompts you to resume or end the workout, touch the Cadence Timeout button and select the desired time. Then, touch the back button on the screen.

### 7. Turn on or turn off the display demo mode.

The console features a display demo mode, designed to be used if the exercise bike is displayed in a store. While the demo mode is turned on, the screen will show a preset presentation when the exercise bike is not in use.

To turn on or turn off the display demo mode, first touch the Demo Mode button. Next, touch the On checkbox or the Off checkbox. Then, touch the back button on the screen.

### 8. Hide or display the gears button.

The console features an option to hide the gears button to prevent unauthorized users from accessing the settings main menu.

To hide or display the gears button, touch the Hide Settings button and select the desired checkbox. Then, follow the prompts on the screen.

**IMPORTANT:** To access the settings main menu when the gears button is hidden, draw a square clockwise on the screen.

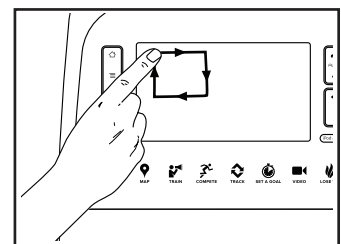

## 9. Select a language.

To select a language, touch the Language button and select the desired language.

## 10. Enable or disable a passcode.

The console features a child safety passcode, designed to prevent unauthorized users from using the exercise bike.

Touch the Passcode button. To enable a passcode, touch the Enable checkbox. Then, enter a 4-digit passcode of your choice. Touch Save to use this passcode. Touch Cancel to return to the equipment settings mode and not use a passcode. To disable the passcode, touch the Disable checkbox.

Note: If a passcode is enabled, the console will regularly ask for you to enter the passcode. The console will remain locked until the correct passcode is entered. **IMPORTANT: If you forget your passcode, enter the following master passcode to unlock the console: 1985.**

## 11. Start the introductory slideshow.

To view an introductory slideshow about the console displays, touch the Start Intro Slideshow button.

## 12. Enable or disable street view.

During some workouts, the screen may show a map. To enable or disable the street view feature of the maps, first touch the Street View button. Next, touch the Enable checkbox or the Disable checkbox. Then, touch the back button on the screen.

## 13. Select a time zone.

To select a time zone, touch the Timezone button and select the desired time zone. Then, touch the back button on the screen.

## 14. Select an update time.

To select a time for automatic console updates, touch the Update Time button and select the desired time. Then, touch the back button on the screen.

**When you select an update time, you must also enable automatic console updates (see step 4).**

**IMPORTANT: You must still unplug the power adapter after using your exercise bike. Set the update time for a time when you normally use your exercise bike and will be available to unplug the power adapter after an update.**

## 15. Select the unit of measurement.

Touch the US/Metric button to view the selected unit of measurement. Next, touch the checkbox for the desired unit of measurement. Then, touch the back button on the screen.

## 16. Select a warm-up segment option.

When you select a workout, there may be a warm-up segment before the workout begins. To select a time for the warm-up segment or to disable the warm-up segment, touch the Warm Up Time button and select the desired option. Then, touch the back button on the screen.

## 17. Exit the equipment settings mode.

To exit the equipment settings mode, press the back button on the console or touch the back button on the screen.

## HOW TO USE THE MAINTENANCE MODE

**IMPORTANT: Some of the features described may not be enabled. Occasionally, a firmware update may add new features or cause your console to function slightly differently.**

### 1. Select the settings main menu.

See step 1 on page 26.

### 2. Select the maintenance mode.

In the settings main menu, touch the Maintenance button to enter the maintenance mode.

The maintenance mode main screen will show information about the console and the wireless network.

### 3. Update the console firmware.

For the best results, regularly check for firmware updates.

Touch the Firmware Update button to check for firmware updates using your wireless network. The update will begin automatically.

**IMPORTANT: To avoid damaging the exercise bike, do not unplug the power adapter while the firmware is being updated.**

The screen will show the progress of the update. When the update is complete, the exercise bike will turn off and then turn back on. If it does not, unplug the power adapter, wait for several seconds, and then plug in the power adapter. Note: It may take a few minutes for the console to be ready for use.

Note: Occasionally, a firmware update may cause your console to function slightly differently. These updates are always designed to improve your exercise experience.

### 4. Calibrate the screen.

If the screen is not properly calibrated, it will be difficult for you to touch the correct buttons on the screen. To calibrate the screen, touch the Calibrate Screen button. A small target will appear on the screen. Note: Touch the Cancel button to return to the maintenance mode.

Touch the center of the target for several seconds. Then, touch the rest of the targets in the same way. After several seconds, the console will exit the calibration mode.

### 5. View machine information.

Touch the Machine Info button to view information about your exercise bike. After you view the information, touch the back button on the screen.

### 6. Find keycodes.

This option is intended to be used by service technicians to identify whether a certain button is working correctly.

### 7. Enter a custom IP address.

If your network does not automatically generate IP addresses, touch the Custom IP button to enter a custom IP address.

### 8. Reset the console to the factory default settings.

Touch the Factory Reset button and follow the instructions on the screen to reset the console to the factory default settings. **IMPORTANT: If you reset the console, you will lose all of your custom console settings.**

### 9. Exit the maintenance mode.

To exit the maintenance mode, press the back button on the console or touch the back button on the screen.

## HOW TO USE THE WIRELESS NETWORK MODE

The console features a wireless network mode that allows you to set up a wireless network connection.

Note: You must have your own wireless network and an 802.11b/g/n router with SSID broadcast enabled (hidden networks are not supported).

### 1. Select the settings main menu.

See step 1 on page 26.

### 2. Select the wireless network mode.

In the settings main menu, touch the Network Setup button to enter the wireless network mode.

Note: You can also touch the wireless symbol to enter the wireless network mode.

### 3. Enable Wi-Fi.

Make sure that the Wi-Fi checkbox is marked with a green checkmark. If it is not, touch the Wi-Fi menu option once and wait for a few seconds. The console will search for available wireless networks.

### 4. Set up and manage a wireless network connection.

When Wi-Fi® is enabled, the screen will show a list of available networks. Note: It may take several seconds for the list of wireless networks to appear.

Make sure that the checkbox on the Network notification menu option is marked with a green checkmark to have the console notify you when a wireless network is within range and available.

When a list of networks appears, touch the desired network. Note: You will need to know your network

name (SSID). If your network has a password, you will also need to know the password.

An information box will ask if you want to connect to the wireless network. Touch the Connect button to connect to the network or touch the Cancel button to return to the list of networks. If the network has a password, touch the password entry box. A keyboard will appear on the screen. To view the password as you type it, touch the Show Password checkbox.

To use the keyboard, see HOW TO USE THE TOUCH SCREEN on page 20.

When the console is connected to your wireless network, the WiFi menu option at the top of the screen will display the word CONNECTED.

To disconnect from a wireless network, select the wireless network and then touch the Forget button.

If you are having problems connecting to an encrypted network, make sure that your password is correct. Note: Passwords are case-sensitive.

Note: The iFit mode supports unsecured and secured (WEP, WPA™, and WPA2™) encryption. A broadband connection is recommended; performance depends on connection speed.

**Note: If you have questions after following these instructions, go to [support.iFit.com](http://support.iFit.com) for assistance.**

### 5. Exit the wireless network mode.

To exit the wireless network mode, press the back button on the console or touch the back button on the screen.

## HOW TO USE THE SOUND SYSTEM

To play music or audio books through the console sound system while you exercise, plug a 3.5 mm male to 3.5 mm male audio cable (not included) into the jack on the console and into a jack on your MP3 player, CD player, or other personal audio player; **make sure that the audio cable is fully plugged in. Note: To purchase an audio cable, see your local electronics store.**

Next, press the play button on your personal audio player. Adjust the volume level using the volume increase and decrease buttons on the console or the volume control on your personal audio player.

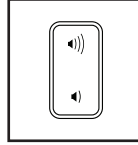

You can also press the Volume increase and decrease buttons on the left seat handlebar.

If you are using a personal CD player and the CD skips, set the CD player on the floor or another flat surface instead of on the console.

## HOW TO USE THE INTERNET BROWSER

Note: To use the Internet browser, you must have access to a wireless network including a wireless router (802.11b/g/n) with SSID broadcast enabled (hidden networks are not supported).

To open the Internet browser, touch the globe button at the bottom of the screen. Then, select a website.

To navigate the Internet browser, touch the Back, Refresh, and Forward buttons on the screen. To exit the Internet browser, touch the Return button on the screen.

To use the keyboard, see HOW TO USE THE TOUCH SCREEN on page 20.

To enter a different web address in the URL bar, first, slide your finger down the screen to view the URL bar, if necessary. Then, touch the URL bar, use the keyboard to enter the address, and touch the Go button.

Note: While you are using the Internet browser, the resistance, fan, and volume buttons will still function, but the workout buttons will not function.

**Note: If you have questions after following these instructions, go to [support.iFit.com](http://support.iFit.com) for assistance.**

---

## FCC INFORMATION

This equipment has been tested and found to comply with the limits for a Class B digital device, pursuant to Part 15 of the FCC Rules. These limits are designed to provide reasonable protection against harmful interference in a residential installation. This equipment generates, uses, and can radiate radio frequency energy and, if not installed and used in accordance with the instructions, may cause harmful interference to radio communications. However, there is no guarantee that interference will not occur in a particular installation. If this equipment does cause harmful interference to radio or television reception, which can be determined by turning the equipment off and on, try to correct the interference by one or more of the following measures:

- Reorient or relocate the receiving antenna.
- Increase the separation between the equipment and the receiver.
- Connect the equipment into an outlet on a circuit different from that to which the receiver is connected.
- Consult the dealer or an experienced radio/TV technician for help.

**FCC CAUTION: To assure continued compliance, use only shielded interface cables when connecting to computer or peripheral devices. Changes or modifications not expressly approved by the party responsible for compliance could void the user's authority to operate this equipment.**

**IMPORTANT: To satisfy exposure compliance requirements, the antenna and transmitter in the console must be at least 8 in. (20 cm) from all persons and must not be near or connected to any other antenna or transmitter.**

**Note: The console contains FCC ID: OMC339918 and OMCIABR12.**

# MAINTENANCE AND TROUBLESHOOTING

## MAINTENANCE

Inspect and tighten all parts of the exercise bike regularly. Replace any worn parts immediately.

To clean the exercise bike, use a damp cloth and a small amount of mild soap. **IMPORTANT: To avoid damage to the console, keep liquids away from the console and keep the console out of direct sunlight.**

## CONSOLE TROUBLESHOOTING

If the console does not turn on, make sure that the power adapter is fully plugged in.

If the console does not display your heart rate when you use the handgrip heart rate monitor, see step 5 on page 21.

If it is difficult for you to touch the correct buttons on the screen, the screen may not be properly calibrated. To calibrate the screen, see step 4 on page 28.

**If a replacement power adapter is needed, call the telephone number on the cover of this manual. IMPORTANT: To avoid damaging the console, use only a manufacturer-supplied regulated power adapter.**

## HOW TO ADJUST THE REED SWITCH

If the console does not display correct feedback, the reed switch should be adjusted.

To adjust the reed switch, first **unplug the power adapter**.

See **EXPLODED DRAWING A** on page 38. Using a standard screwdriver, gently release the tabs on the Top Shield (44). Slide the Top Shield upward.

Next, remove the M4 x 16mm Screw (77) from the Access Cover (40). Then, remove the Access Cover.

Locate the Reed Switch (46). Turn the Left Crank Arm (24) until a Pulley Magnet (30) is aligned with the Reed Switch. Next, loosen, but do not remove, the indicated M4 x 16mm Screw (77). Slide the Reed Switch slightly closer to or away from the Pulley Magnet, and then retighten the Screw.

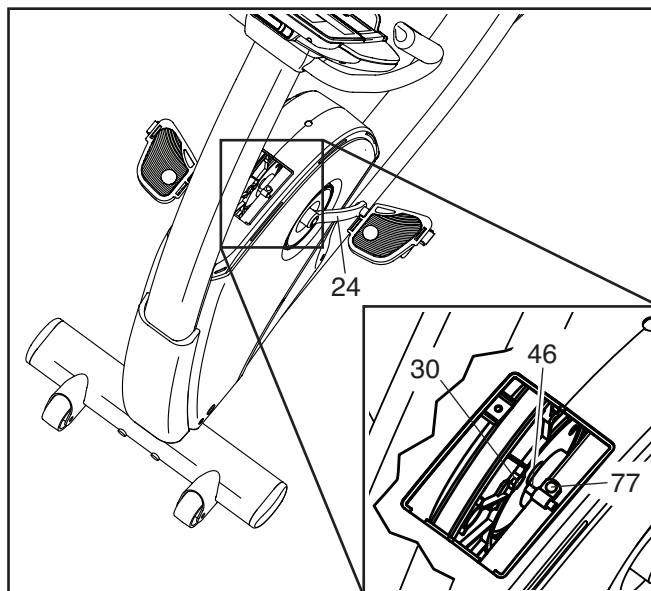

Plug in the power adapter, and turn the Left Crank Arm (24) for a moment. Repeat these actions until the console displays correct feedback.

When the reed switch is correctly adjusted, unplug the power adapter and reattach the parts that you removed. Then, plug in the power adapter.



## HOW TO ADJUST THE DRIVE BELT

If the pedals slip while you are pedaling, even while the resistance is adjusted to the highest setting, the drive belt may need to be adjusted.

To adjust the drive belt, first **unplug the power adapter**.

See **EXPLODED DRAWING B on page 39**. Using an adjustable wrench, turn the Right Pedal (21) counterclockwise and remove it.

See **EXPLODED DRAWING A on page 38**. Using a standard screwdriver, gently release the tabs on the Front Shield (58) and the Top Shield (44). Remove the Front Shield and slide the Top Shield upward.

Remove all the Screws (77, 85) from the Left and Right Front Shields (13, 14); **make sure to note the location of each size of Screw**.

Using a standard screwdriver, gently release the tabs on the right Shield Disc (52). Rotate the Shield Disc and remove it. Then, gently remove the Right Front Shield (14).

Next, loosen the M6 x 20mm Hex Screw (84). Tighten the M10 x 50mm Hex Screw (83) until the Drive Belt (47) is tight. When the Drive Belt is tight, tighten the M6 x 20mm Hex Screw.

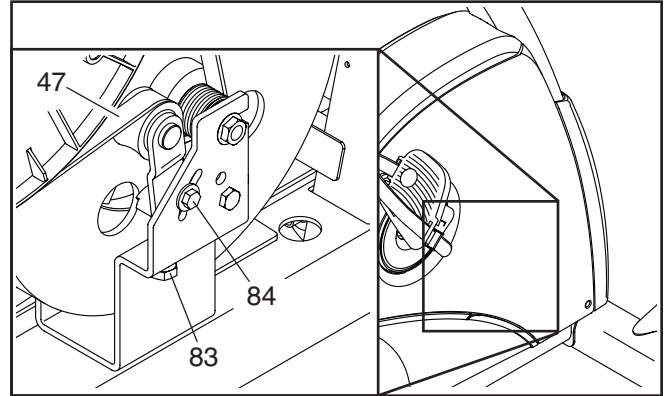

When the drive belt is correctly adjusted, reattach the parts that you removed. Then, plug in the power adapter.

# EXERCISE GUIDELINES

**⚠️ WARNING:** Before beginning this or any exercise program, consult your physician. This is especially important for persons over age 35 or persons with pre-existing health problems.

The heart rate monitor is not a medical device. Various factors may affect the accuracy of heart rate readings. The heart rate monitor is intended only as an exercise aid in determining heart rate trends in general.

These guidelines will help you to plan your exercise program. For detailed exercise information, obtain a reputable book or consult your physician. Remember, proper nutrition and adequate rest are essential for successful results.

## EXERCISE INTENSITY

Whether your goal is to burn fat or to strengthen your cardiovascular system, exercising at the proper intensity is the key to achieving results. You can use your heart rate as a guide to find the proper intensity level. The chart below shows recommended heart rates for fat burning and aerobic exercise.

165	155	145	140	130	125	115	♥
145	138	130	125	118	110	103	♥
125	120	115	110	105	95	90	♥
<hr/>							
20	30	40	50	60	70	80	

To find the proper intensity level, find your age at the bottom of the chart (ages are rounded off to the nearest ten years). The three numbers listed above your age define your “training zone.” The lowest number is the heart rate for fat burning, the middle number is the heart rate for maximum fat burning, and the highest number is the heart rate for aerobic exercise.

**Burning Fat**—To burn fat effectively, you must exercise at a low intensity level for a sustained period of time. During the first few minutes of exercise, your body uses carbohydrate calories for energy. Only after the first few minutes of exercise does your body begin to use stored fat calories for energy. If your goal is to burn fat, adjust the intensity of your exercise until your heart rate is near the lowest number in your training zone. For maximum fat burning, exercise with your heart rate near the middle number in your training zone.

**Aerobic Exercise**—If your goal is to strengthen your cardiovascular system, you must perform aerobic exercise, which is activity that requires large amounts of oxygen for prolonged periods of time. For aerobic exercise, adjust the intensity of your exercise until your heart rate is near the highest number in your training zone.

## WORKOUT GUIDELINES

**Warming Up**—Start with 5 to 10 minutes of stretching and light exercise. A warm-up increases your body temperature, heart rate, and circulation in preparation for exercise.

**Training Zone Exercise**—Exercise for 20 to 30 minutes with your heart rate in your training zone. (During the first few weeks of your exercise program, do not keep your heart rate in your training zone for longer than 20 minutes.) Breathe regularly and deeply as you exercise; never hold your breath.

**Cooling Down**—Finish with 5 to 10 minutes of stretching. Stretching increases the flexibility of your muscles and helps to prevent post-exercise problems.

## EXERCISE FREQUENCY

To maintain or improve your condition, complete three workouts each week, with at least one day of rest between workouts. After a few months of regular exercise, you may complete up to five workouts each week, if desired. Remember, the key to success is to make exercise a regular and enjoyable part of your everyday life.

## SUGGESTED STRETCHES

The correct form for several basic stretches is shown at the right. Move slowly as you stretch; never bounce.

### 1. Toe Touch Stretch

Stand with your knees bent slightly and slowly bend forward from your hips. Allow your back and shoulders to relax as you reach down toward your toes as far as possible. Hold for 15 counts, then relax. Repeat 3 times. Stretches: Hamstrings, back of knees and back.

### 2. Hamstring Stretch

Sit with one leg extended. Bring the sole of the opposite foot toward you and rest it against the inner thigh of your extended leg. Reach toward your toes as far as possible. Hold for 15 counts, then relax. Repeat 3 times for each leg. Stretches: Hamstrings, lower back and groin.

### 3. Calf/Achilles Stretch

With one leg in front of the other, reach forward and place your hands against a wall. Keep your back leg straight and your back foot flat on the floor. Bend your front leg, lean forward and move your hips toward the wall. Hold for 15 counts, then relax. Repeat 3 times for each leg. To cause further stretching of the achilles tendons, bend your back leg as well. Stretches: Calves, achilles tendons and ankles.

### 4. Quadriceps Stretch

With one hand against a wall for balance, reach back and grasp one foot with your other hand. Bring your heel as close to your buttocks as possible. Hold for 15 counts, then relax. Repeat 3 times for each leg. Stretches: Quadriceps and hip muscles.

### 5. Inner Thigh Stretch

Sit with the soles of your feet together and your knees outward. Pull your feet toward your groin area as far as possible. Hold for 15 counts, then relax. Repeat 3 times. Stretches: Quadriceps and hip muscles.

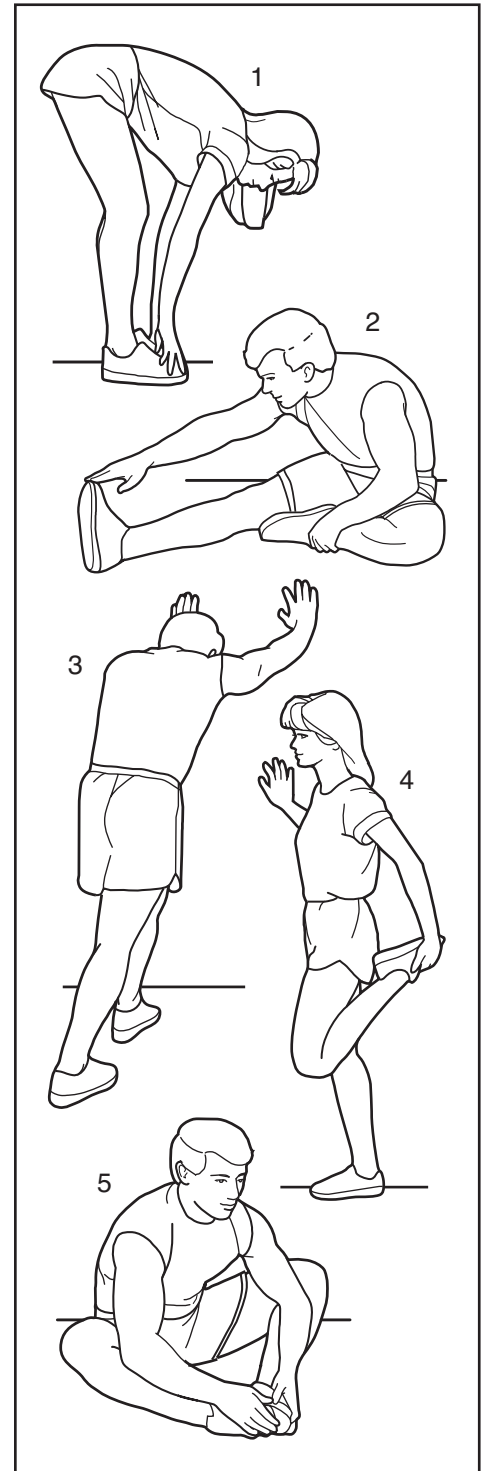

# PART LIST

Model No. NTEX89914.0 R0115B

Key No.	Qty.	Description	Key No.	Qty.	Description
1	1	Frame	46	1	Reed Switch/Wire
2	1	Upright	47	1	Drive Belt
3	2	Foot	48	4	Stabilizer Cap
4	1	Console	49	1	Left Handlebar Grip
5	1	Rail	50	2	Flange Screw
6	1	Adjustment Bar	51	1	Power Adapter
7	1	Handlebar	52	2	Shield Disc
8	1	Backrest	53	1	Tablet Holder
9	1	Seat	54	4	#8 x 13mm Screw
10	1	Seat Handlebar/Wire	55	8	Carriage Bearing
11	1	Seat Handlebar Cap	56	1	Accessory Tray
12	1	Brake Block	57	1	Upright Cover
13	1	Left Front Shield	58	1	Front Shield
14	1	Right Front Shield	59	8	Carriage Bushing
15	1	Front Stabilizer	60	2	Rail Rod
16	1	Rear Stabilizer	61	1	M6 x 20mm Shoulder Screw
17	2	Wheel	62	4	Rod Cap
18	1	Brake	63	2	Brake Spacer
19	2	Leveling Foot	64	5	M6 x 15mm Screw
20	1	Right Handlebar Grip	65	4	M10 x 122mm Screw
21	1	Right Pedal/Strap	66	2	Wheel Bolt
22	1	Left Pedal/Strap	67	4	M8 x 38mm Screw
23	1	Right Crank Arm	68	1	M6 Large Washer
24	1	Left Crank Arm	69	2	M8 x 22mm Screw
25	4	M6 x 18mm Screw	70	4	M10 x 62mm Screw
26	1	Adjustment Bar Handle	71	2	M6 x 15mm Screw
27	1	Handle Bracket	72	1	Grommet
28	2	Large Snap Ring	73	2	M6 x 14mm Screw
29	1	Pulley	74	8	M8 x 30mm Bolt
30	2	Pulley Magnet	75	8	M6 x 30mm Screw
31	1	Crank	76	1	M8 x 28mm Hex Screw
32	1	Brake Axle	77	40	M4 x 16mm Screw
33	2	Crank Bearing	78	4	M8 x 18mm Screw
34	1	Eddy Mechanism	79	1	M4 x 16mm Bright Screw
35	2	Mechanism Spacer	80	4	Rail Screw
36	1	Front Rail Cover	81	1	Backrest Back
37	1	Resistance Motor	82	4	M4 x 12mm Flange Screw
38	11	Mushroom Fastener/Screw	83	1	M10 x 50mm Hex Screw
39	1	Idler	84	1	M6 x 20mm Hex Screw
40	1	Access Cover	85	8	M4 x 25mm Screw
41	1	Seat Carriage	86	2	#6 x 12mm Screw
42	1	Frame Pulse Wire/Receptacle	87	2	M10 Locknut
43	1	Main Wire	88	8	M6 Washer
44	1	Top Shield	89	12	M8 Jam Nut
45	1	Clamp	90	1	Rear Rail Cover

Key No.	Qty.	Description	Key No.	Qty.	Description
91	8	M8 Split Washer	100	1	Clip Nut
92	2	Crank Cap	101	1	M6 Locknut
93	1	Barrel Nut	102	1	M6 x 65mm Bolt
94	7	Tree Fastener	103	1	Power Receptacle/Wire
95	2	M10 Flange Nut	104	1	Chest Heart Rate Monitor
96	2	M6 Split Washer	105	1	Chest Strap
97	1	Right Rear Shield	*	–	Assembly Tool
98	1	Left Rear Shield	*	–	User's Manual
99	4	M6 Small Washer			

Note: Specifications are subject to change without notice. For information about ordering replacement parts, see the back cover of this manual. \*These parts are not illustrated.

# EXPLODED DRAWING A

Model No. NTEX89914.0 R0115B

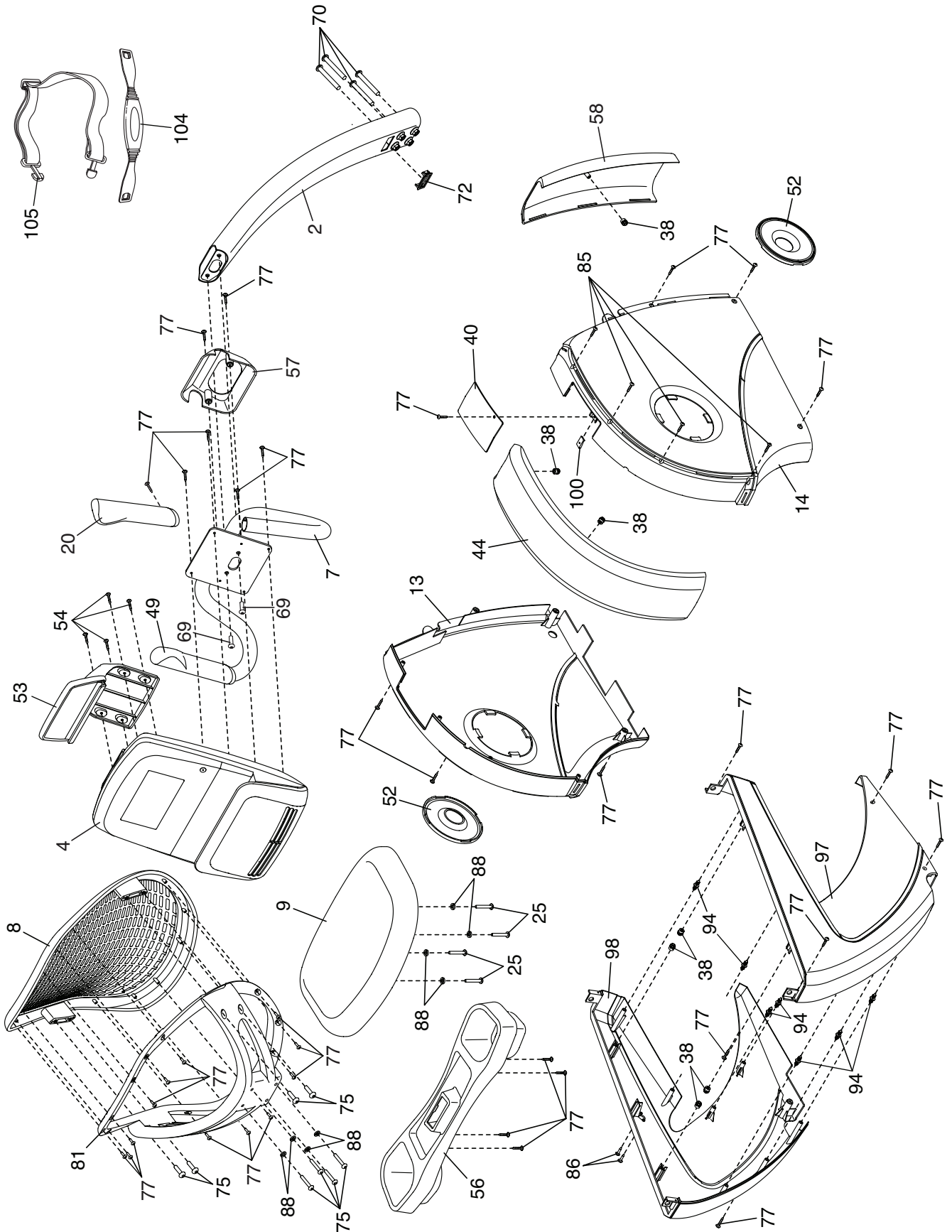

# EXPLODED DRAWING B

Model No. NTEX89914.0 R0115B

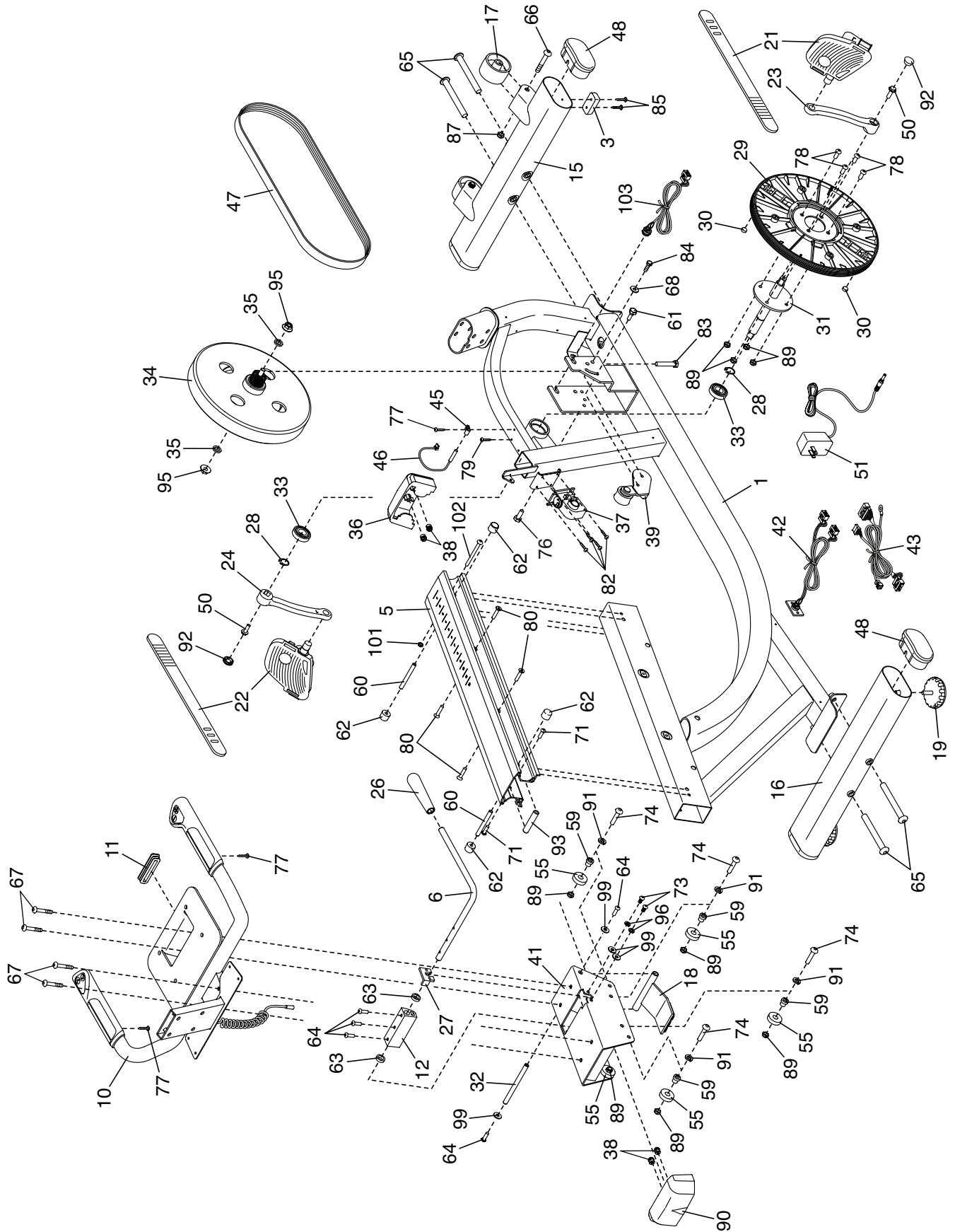

---

# ORDERING REPLACEMENT PARTS

To order replacement parts, please see the front cover of this manual. To help us assist you, be prepared to provide the following information when contacting us:

- the model number and serial number of the product (see the front cover of this manual)
- the name of the product (see the front cover of this manual)
- the key number and description of the replacement part(s) (see the PART LIST and the EXPLODED DRAWING near the end of this manual)

## LIMITED WARRANTY

**IMPORTANT: To protect your fitness equipment with an extended service plan, see page 5.**

ICON Health & Fitness, Inc. (ICON) warrants this product to be free from defects in workmanship and material, under normal use and service conditions. The frame and the eddy mechanism are warranted for a lifetime. Parts are warranted for three (3) years from the date of purchase. Labor is warranted for one (1) year from the date of purchase.

This warranty extends only to the original purchaser (customer). ICON's obligation under this warranty is limited to repairing or replacing, at ICON's option, the product through one of its authorized service centers. All repairs for which warranty claims are made must be preauthorized by ICON. If the product is shipped to a service center, freight charges to and from the service center will be the customer's responsibility. If replacement parts are shipped while the product is under warranty, the customer will be responsible for a minimal handling charge. For in-home service, the customer will be responsible for a minimal trip charge. This warranty does not extend to freight damage to the product. This warranty will automatically be voided if the product is used as a store display model, if the product is purchased or transported outside the USA, if all instructions in this manual are not followed, if the product is abused or improperly or abnormally used, or if the product is used for commercial or rental purposes. No other warranty beyond that specifically set forth above is authorized by ICON.

ICON is not responsible or liable for indirect, special, or consequential damages arising out of or in connection with the use or performance of the product; damages with respect to any economic loss, loss of property, loss of revenues or profits, loss of enjoyment or use, or costs of removal or installation; or other consequential damages of any kind. Some states do not allow the exclusion or limitation of incidental or consequential damages. Accordingly, the above limitation may not apply to the customer.

The warranty extended hereunder is in lieu of any and all other warranties, and any implied warranties of merchantability or fitness for a particular purpose are limited in their scope and duration to the terms set forth herein. Some states do not allow limitations on how long an implied warranty lasts. Accordingly, the above limitation may not apply to the customer.

This warranty provides specific legal rights; the customer may have other rights that vary from state to state.

**ICON Health & Fitness, Inc., 1500 S. 1000 W., Logan, UT 84321-9813**