

NordicTrack[®]

COMMERCIAL 2450

www.nordictrack.com

Model No. NTL17215.0

Serial No. _____

Write the serial number in the space above for reference.

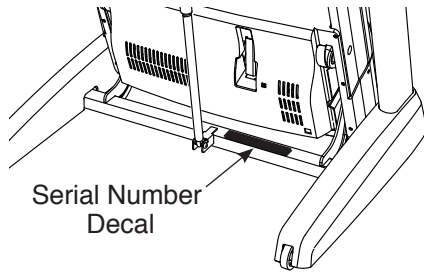

ACTIVATE YOUR WARRANTY

To register your product and activate your warranty today, go to www.nordictrackservice.com/registration.

CUSTOMER CARE

For service at any time, go to www.nordictrackservice.com.

Or call 1-800-TO-BE-FIT
(1-800-862-3348)
Mon.–Fri. 6 a.m.–6 p.m. MT
Sat. 8 a.m.–12 p.m. MT

Please do not contact the store.

CAUTION

Read all precautions and instructions in this manual before using this equipment. Save this manual for future reference.

USER'S MANUAL

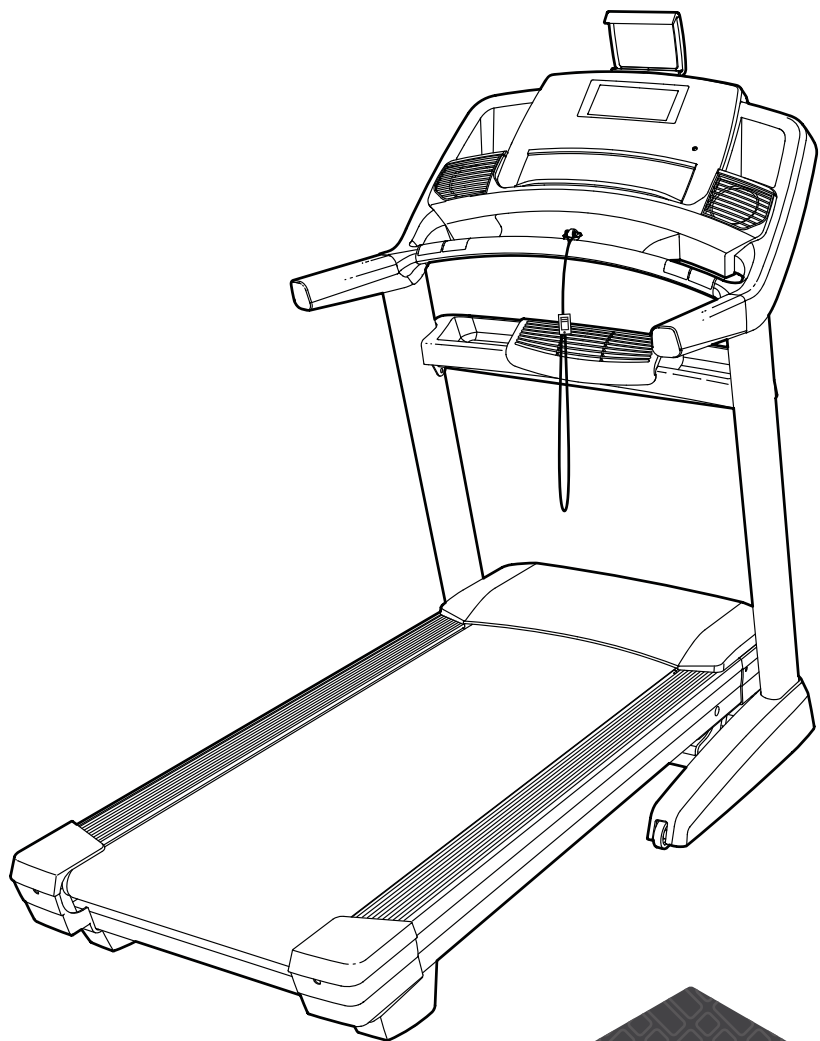
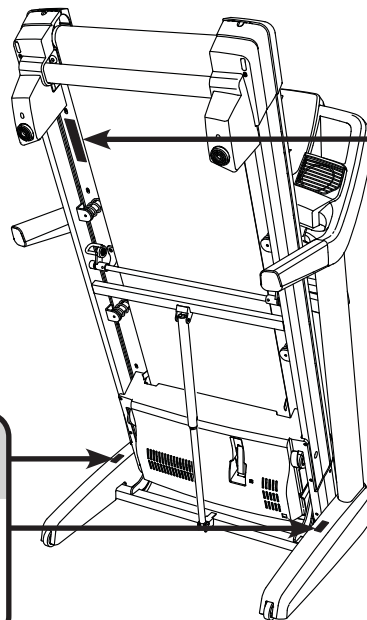

TABLE OF CONTENTS

WARNING DECAL PLACEMENT	2
IMPORTANT PRECAUTIONS	3
BEFORE YOU BEGIN	7
PART IDENTIFICATION CHART	8
ASSEMBLY	9
THE CHEST HEART RATE MONITOR	16
HOW TO USE THE TREADMILL	17
HOW TO UPGRADE THE CONSOLE	18
HOW TO FOLD AND MOVE THE TREADMILL	32
MAINTENANCE AND TROUBLESHOOTING	33
EXERCISE GUIDELINES	36
PART LIST	38
EXPLODED DRAWING	40
ORDERING REPLACEMENT PARTS	Back Cover
LIMITED WARRANTY	Back Cover

WARNING DECAL PLACEMENT

This drawing shows the locations of the warning decals. **If a decal is missing or illegible, call the telephone number on the front cover of this manual and request a free replacement decal. Apply the decal in the location shown.**
 Note: The decals may not be shown at actual size.



▲ WARNING:
 Protect yourself and others from risk of serious injury. Read the user's manual, and:

- Stand only on the side rails when starting or stopping treadmill.
- Change speed in small increments.
- Hold handrails to prevent falling, and always wear the safety clip while operating the treadmill.
- Stop if you feel faint, dizzy, or short of breath.
- Fully engage the storage latch before the treadmill is moved or stored.
- Incline should be set to zero before folding the treadmill into a storage position.
- Never allow children on or around the treadmill.
- Remove the safety key when treadmill is not in use.
- Keep clothing, fingers, and hair away from moving parts.
- Never try to adjust or fix the belt while it is moving.
- Always wear athletic shoes while operating the treadmill.

The BLUETOOTH® word mark and logos are registered trademarks of Bluetooth SIG, Inc. and are used under license. Google Maps is a trademark of Google Inc. NORDICTRACK is a registered trademark of ICON Health & Fitness, Inc.

IMPORTANT PRECAUTIONS

⚠️ WARNING: To reduce the risk of burns, fire, electric shock, or injury to persons, read all important precautions and instructions in this manual and all warnings on your treadmill before using your treadmill. ICON assumes no responsibility for personal injury or property damage sustained by or through the use of this product.

1. It is the responsibility of the owner to ensure that all users of this treadmill are adequately informed of all warnings and precautions.
2. Before beginning any exercise program, consult your physician. This is especially important for persons over age 35 or persons with pre-existing health problems.
3. The treadmill is not intended for use by persons with reduced physical, sensory, or mental capabilities or lack of experience and knowledge, unless they have been given supervision or instruction concerning use of the treadmill by someone responsible for their safety.
4. Use the treadmill only as described in this manual.
5. The treadmill is intended for home use only. Do not use the treadmill in any commercial, rental, or institutional setting.
6. Keep the treadmill indoors, away from moisture and dust. Do not put the treadmill in a garage or covered patio, or near water.
7. Place the treadmill on a level surface, with at least 8 ft. (2.4 m) of clearance behind it and 2 ft. (0.6 m) on each side. Do not place the treadmill on any surface that blocks air openings. To protect the floor or carpet from damage, place a mat under the treadmill.
8. Do not operate the treadmill where aerosol products are used or where oxygen is being administered.
9. Keep children under age 13 and pets away from the treadmill at all times.
10. The treadmill should be used only by persons weighing 300 lbs. (136 kg) or less.
11. Never allow more than one person on the treadmill at a time.
12. Wear appropriate exercise clothes while using the treadmill. Do not wear loose clothes that could become caught in the treadmill. Athletic support clothes are recommended for both men and women. *Always wear athletic shoes. Never use the treadmill with bare feet, wearing only stockings, or in sandals.*
13. Plug the power cord into a surge suppressor (not included), and plug the surge suppressor into an appropriate outlet (see page 17). To avoid overloading the circuit, do not plug other electrical devices, except for low-power devices such as cell phone chargers, into the surge suppressor or into an outlet on the same circuit.
14. Use only a surge suppressor that meets all of the specifications described on page 17. To purchase a surge suppressor, see your local NORDICTRACK dealer, call the telephone number on the front cover of this manual, or see your local electronics store.
15. Failure to use a properly functioning surge suppressor could result in damage to the control system of the treadmill. If the control system is damaged, the walking belt may slow, accelerate, or stop unexpectedly, which may result in a fall and serious injury.
16. Keep the power cord and the surge suppressor away from heated surfaces.
17. Never move the walking belt while the power is turned off. Do not operate the treadmill if the power cord or plug is damaged, or if the treadmill is not working properly. (See MAINTENANCE AND TROUBLESHOOTING on page 33 if the treadmill is not working properly.)
18. Read, understand, and test the emergency stop procedure before using the treadmill (see HOW TO TURN ON THE POWER on page 20). Always wear the clip while using the treadmill.

19. Always stand on the foot rails when starting or stopping the walking belt. Always hold the handrails while using the treadmill.
20. When a person is walking on the treadmill, the noise level of the treadmill will increase.
21. Keep fingers, hair, and clothing away from the moving walking belt.
22. The treadmill is capable of high speeds. Adjust the speed in small increments to avoid sudden jumps in speed.
23. The heart rate monitor is not a medical device. Various factors, including the user's movement, may affect the accuracy of heart rate readings. The heart rate monitor is intended only as an exercise aid in determining heart rate trends in general.
24. Never leave the treadmill unattended while it is running. Always remove the key, press the power switch into the off position (see the drawing on page 7 for the location of the power switch), and unplug the power cord when the treadmill is not in use.
25. Do not attempt to move the treadmill until it is properly assembled. (See ASSEMBLY on page 9 and HOW TO FOLD AND MOVE THE TREADMILL on page 32.) You must be able to safely lift 45 lbs. (20 kg) to move the treadmill.
26. When folding or moving the treadmill, make sure that the storage latch is holding the frame securely in the storage position.
27. Do not change the incline of the treadmill by placing objects under the treadmill.
28. Never insert any object into any opening on the treadmill.
29. Inspect and properly tighten all parts each time the treadmill is used.
30. **DANGER:** Always unplug the power cord immediately after use, before cleaning the treadmill, and before performing the maintenance and adjustment procedures described in this manual. Never remove the motor hood unless instructed to do so by an authorized service representative. Servicing other than the procedures in this manual should be performed by an authorized service representative only.
31. Over exercising may result in serious injury or death. If you feel faint, if you become short of breath, or if you experience pain while exercising, stop immediately and cool down.
32. **IMPORTANT:** To satisfy exposure compliance requirements, the antenna and transmitter in the console must be at least 8 in. (20 cm) from all persons and must not be near or connected to any other antenna or transmitter. The treadmill console contains FCC ID OMC1ABR12.

SAVE THESE INSTRUCTIONS

MAKE YOUR FITNESS GOALS A **REALITY**

iFIT®

Congratulations on the purchase of your new iFit® compatible fitness equipment. You're just one click away from making your fitness goals a reality.

GO TO IFIT.COM TO GET STARTED

DO MORE THAN JUST WORK OUT

iFit® is the most powerful training tool available to help you accomplish all of your fitness goals. From weight loss and performance to personalized training programs, iFit® is the key to getting more out of everything you do. Some features require paid subscription.



LOSE WEIGHT

Stay on track and motivated with progressive weight loss programs with our trainers, including Jillian Michaels.



COMPETE WITH OTHERS

Push yourself to new limits with real-time virtual races.



PERSONALIZED EVENT TRAINING

5k, 10k, half or full marathon training will help you prepare for your event.



GO MOBILE

Track your workout anywhere you go with iFit® mobile apps.



MAP YOUR ROUTE

With Google Maps™, your fitness equipment will simulate the earth's terrain while displaying Street View during your workout.



SHARE YOUR PROGRESS

Inspire others, motivate yourself and share routes, workouts and more.

GO TO

IFIT.COM

OR CALL

877-236-1009

PROTECT

YOUR FITNESS EQUIPMENT
WITH AN EXTENDED SERVICE PLAN

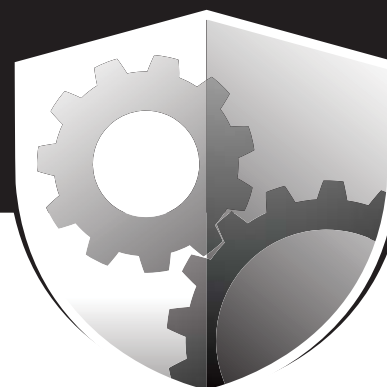

Your new fitness equipment is not an ordinary purchase; it is an investment in your health and well being for years to come.

As the leading provider of manufacturer's extended service plans, ICON strives to protect your equipment and your future.

Please review the following service plans and find one that best fits your needs.

PREVENTIVE MAINTENANCE SERVICE PLANS

Equipment Price	3-Year Plan	5-Year Plan
\$0.00 to \$1000.00	\$199.99	\$289.99
\$1001.00 to \$1500.00	\$259.99	\$379.99
\$1501.00 to \$2500.00	\$339.99	\$489.99
(Bikes/Systems Only) \$0.00 to \$2500.00	\$139.99	NA

Features:

- Includes an annual preventive maintenance and performance check at your convenience
- Unlimited in-home repairs; no shipping required
- Covers parts and labor on all manufacturer's defects, as well as wear and tear on parts
- Up to 5 years of coverage available

STANDARD SERVICE PLANS

Equipment Price	1-Year Plan	2-Year Plan	3-Year Plan
\$0.00 to \$300.00	\$29.99	\$39.99	\$59.99
\$301.00 to \$1000.00	\$89.99	\$119.99	\$149.99
\$1001.00 to \$2000.00	\$109.99	\$139.99	\$179.99
\$2001.00 to \$3000.00	\$179.99	\$209.99	\$239.99

Features:

- Unlimited in-home repairs; no shipping required
- Covers parts and labor on all manufacturer's defects, as well as wear and tear on parts
- Up to 3 years of coverage available

To protect your fitness equipment today, please
call Customer Care at **1-800-677-3838.**
Or, visit us online at **www.utserv.com.**



BEFORE YOU BEGIN

Thank you for selecting the revolutionary NORDICTRACK® COMMERCIAL 2450 treadmill. The COMMERCIAL 2450 treadmill offers an impressive selection of features designed to make your workouts at home more effective and enjoyable. And when you're not exercising, the unique treadmill can be folded up, requiring less than half the floor space of other treadmills.

reading this manual, please see the front cover of this manual. To help us assist you, please note the product model number and serial number before contacting us. The model number and the location of the serial number decal are shown on the front cover of this manual.

Before reading further, please review the drawing below and familiarize yourself with the labeled parts.

For your benefit, read this manual carefully before using the treadmill. If you have questions after

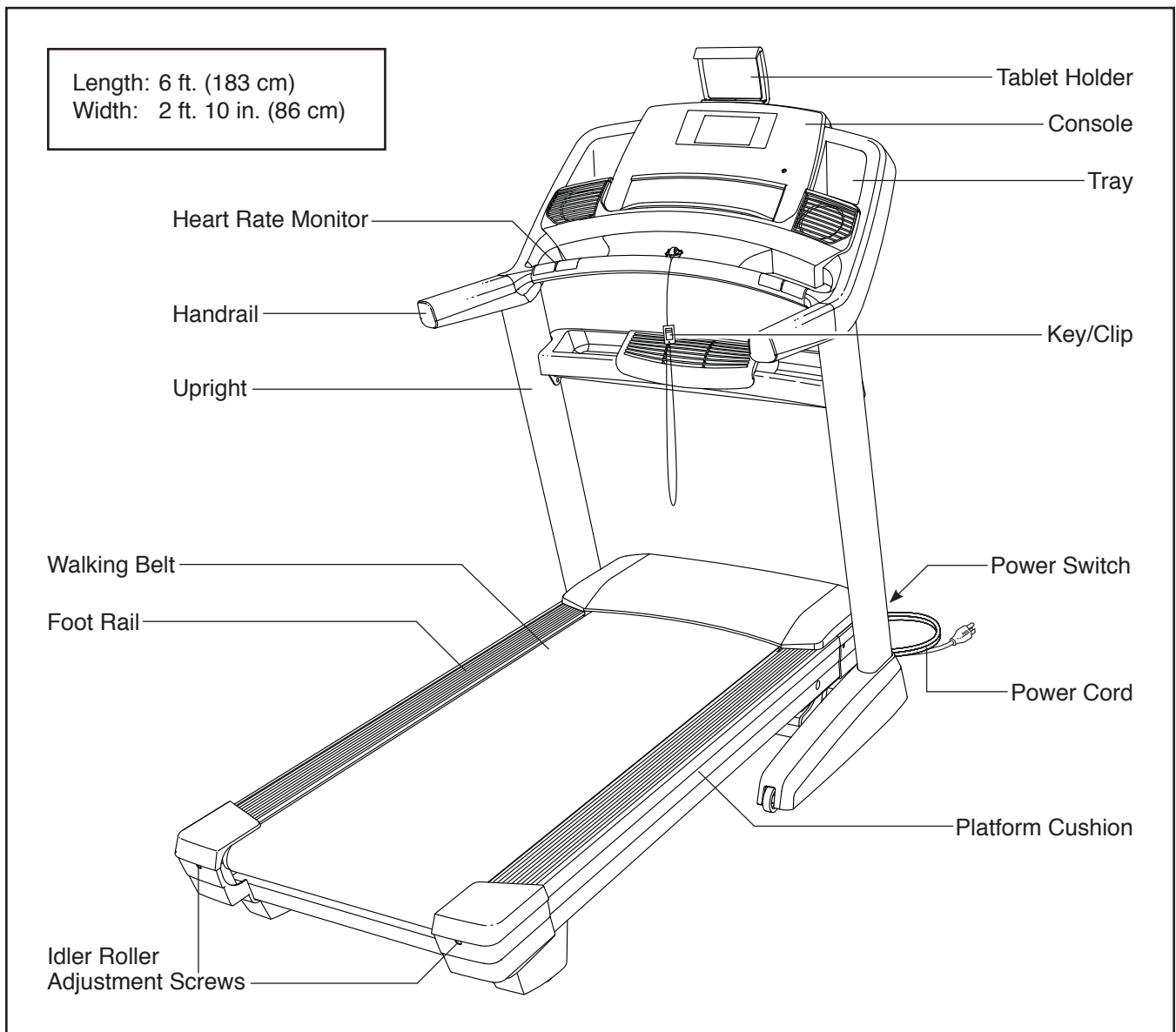

PART IDENTIFICATION CHART

Use the drawings below to identify small parts used for assembly. The number in parentheses below each drawing is the key number of the part, from the PART LIST near the end of this manual. The number following the key number is the quantity used for assembly. **Note: If a part is not in the hardware kit, check to see whether it is preattached. Extra parts may be included.**

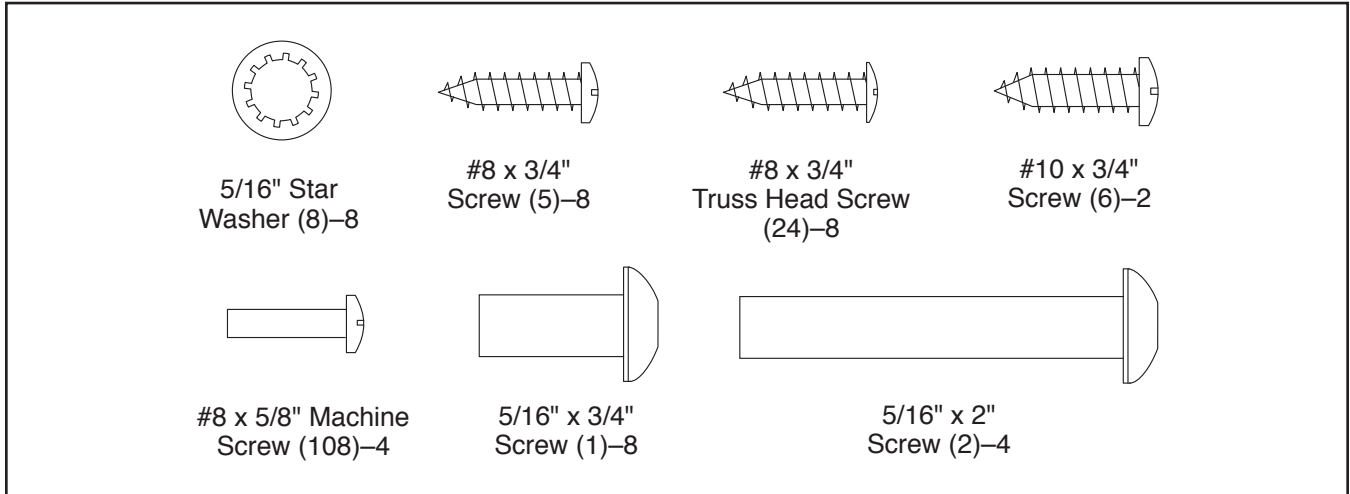

ASSEMBLY

- Assembly requires two persons.
- Place all parts in a cleared area and remove the packing materials. Do not dispose of the packing materials until you finish all assembly steps.
- After shipping, there may be an oily substance on the exterior of the treadmill. This is normal. If there is an oily substance on the treadmill, wipe it off with a soft cloth and a mild, non-abrasive cleaner.
- Left parts are marked “L” or “Left” and right parts are marked “R” or “Right.”

- To identify small parts, see page 8.
- Assembly requires the following tools:

the included hex key



one adjustable wrench



one Phillips screwdriver



To avoid damaging parts, do not use power tools.

1. **Go to www.nordictrackservice.com/ registration on your computer and register your product.**

- activates your warranty
- saves you time if you ever need to contact Customer Care
- allows us to notify you of upgrades and offers

Note: If you do not have Internet access, call Customer Care (see the front cover of this manual) and register your product.

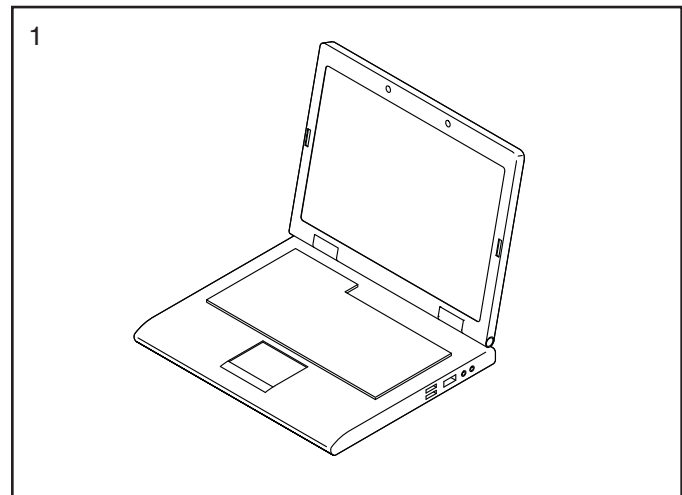

2. **Make sure that the power cord is unplugged.**

Identify the Right Extension Leg (91). Attach the Right Extension Leg to the right Upright (84) with two 5/16" x 3/4" Screws (1); **start both Screws, and then tighten them.**

Attach the Left Extension Leg (not shown) to the left Upright (84) in the same way.

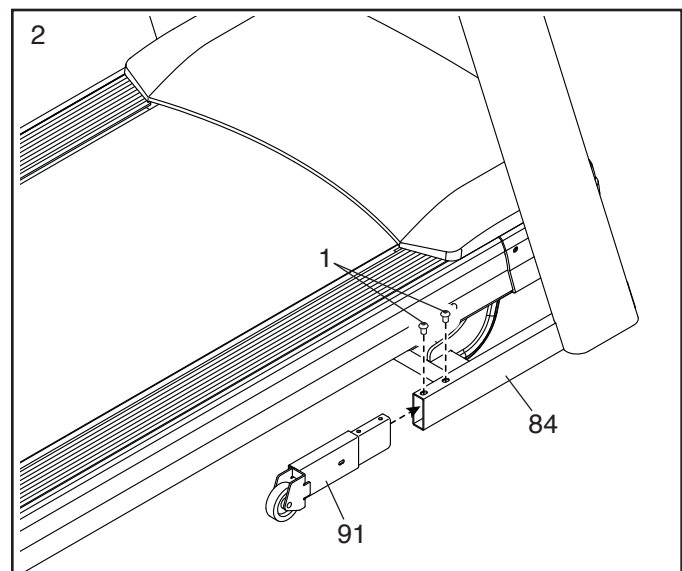

3. Identify the Left and Right Upright Covers (89, 90).

Slide the Left Upright Cover (89) onto the left Upright (84), and slide the Right Upright Cover (90) onto the right Upright. Press the Upright Covers downward until they snap into place.

Then, remove and save the four indicated 5/16" x 2" Screws (2).

If there is a film covering the decal on each Upright (84), carefully remove the film.

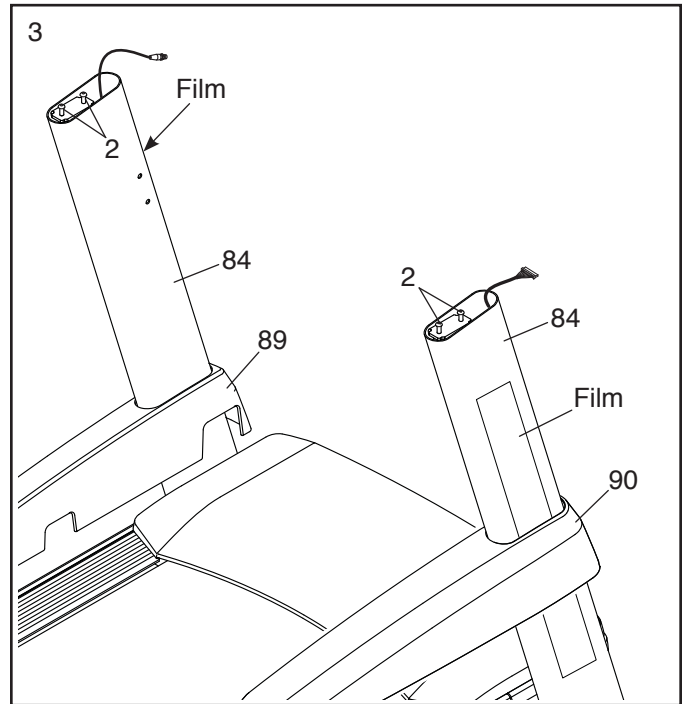

4. Remove and discard the four indicated screws (A). Then, remove the Tray (79) from the Upright Crossbar (76).

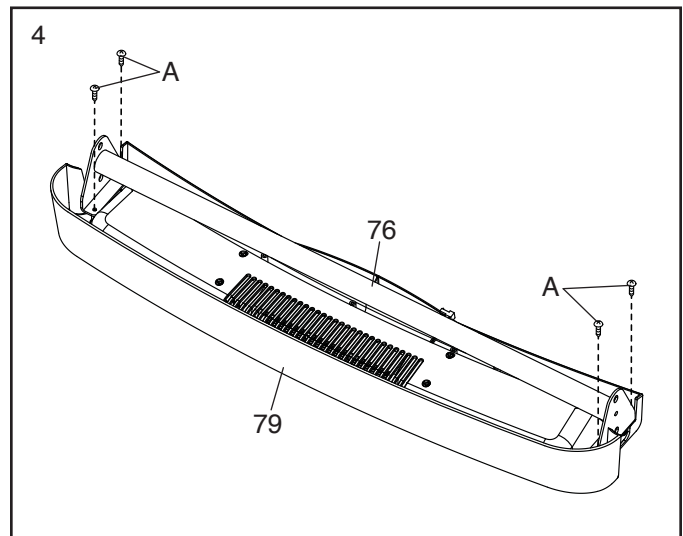

5. Carefully slide the Upright Crossbar (76) between the Uprights (84). Attach the Upright Crossbar with four 5/16" x 3/4" Screws (1); **start all four Screws, and then tighten them.**

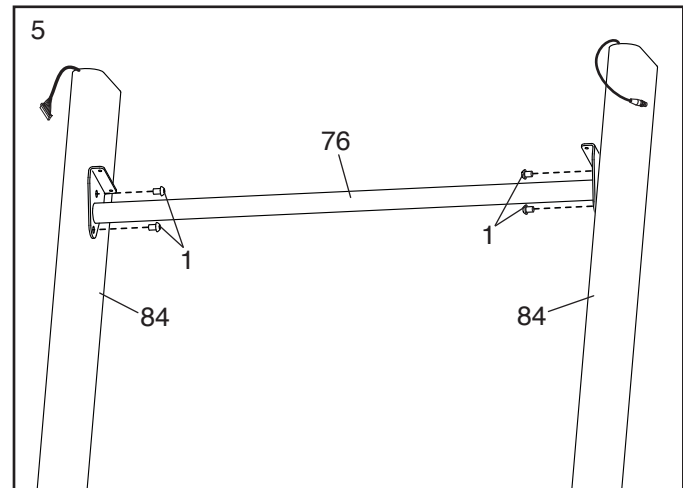

6. Hold the Tray (79) near the right Upright (84). Wrap the tie in the hole in the side of the Upright around the end of the fan wire (B). Pull the fan wire through the hole and out of the top of the Upright. Then, remove the tie.

Identify the #8 x 3/4" Screws (5). **IMPORTANT: Do not confuse the #8 x 3/4" Screws with the #8 x 3/4" Truss Head Screws (24). The #8 x 3/4" Truss Head Screws have flatter heads.**

Attach the Tray (79) to the Upright Crossbar (76) with four #8 x 3/4" Screws (5); **start all four Screws, and then tighten them.**

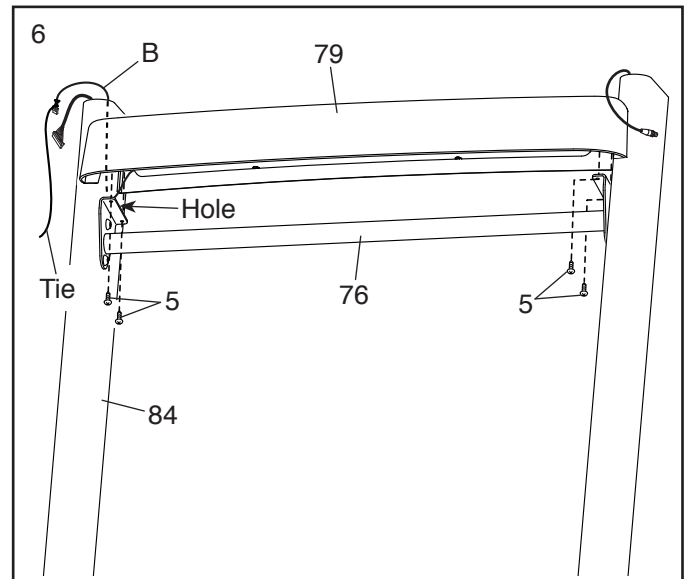

7. Attach the two Handrails (74) to the Uprights (84) with two of the 5/16" x 2" Screws (2) that you removed in step 3 and two 5/16" Star Washers (8); **do not fully tighten the Screws yet. Be careful not to pinch the Upright Coaxial Cable (78), the Upright Wire (83), or the fan wire (B). Position the wires as shown.**

Then, remove and discard the two indicated screws (C).

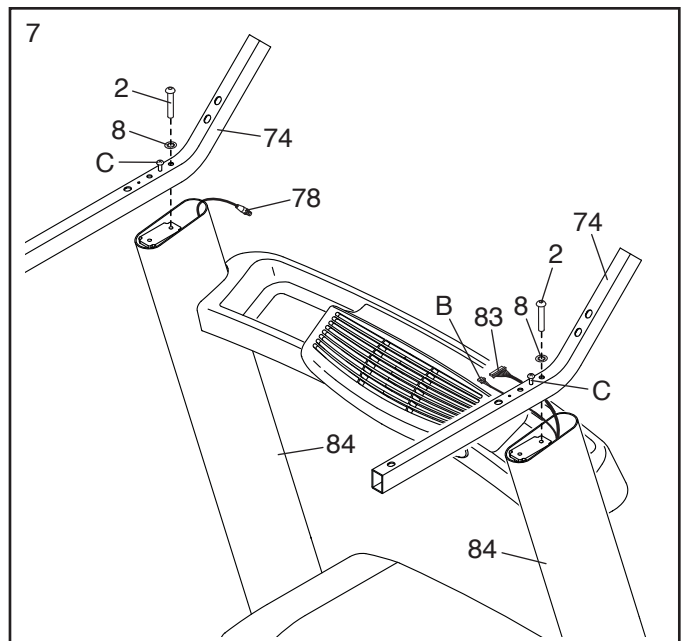

8. Set the console assembly (D) face down on a soft surface to avoid scratching the console assembly.

Remove and discard the four indicated screws (E). Then, remove the Pulse Crossbar (80).

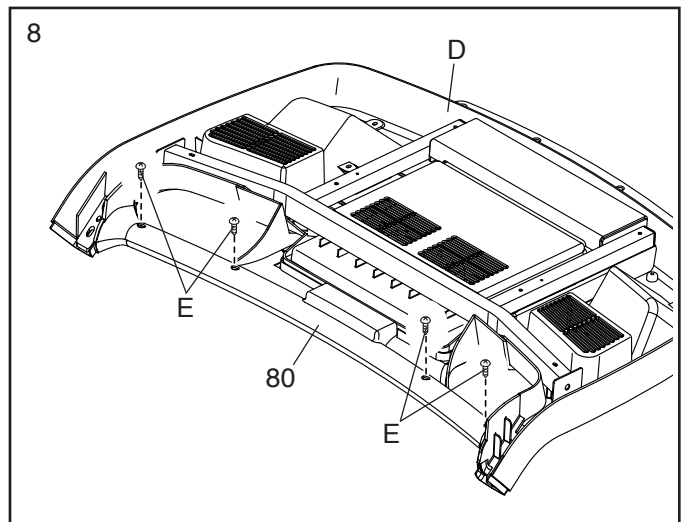

9. **IMPORTANT:** To avoid damaging the Pulse Crossbar (80), do not use power tools, and do not overtighten the #10 x 3/4" Screws (6) or the 5/16" x 2" Screws (2).

Orient the Pulse Crossbar (80) as shown. Attach the Pulse Crossbar with two of the 5/16" x 2" Screws (2) that you removed in step 3, two 5/16" Star Washers (8), and two #10 x 3/4" Screws (6); **start all four Screws, and then tighten them.**

Then, tighten the other two 5/16" x 2" Screws (2).

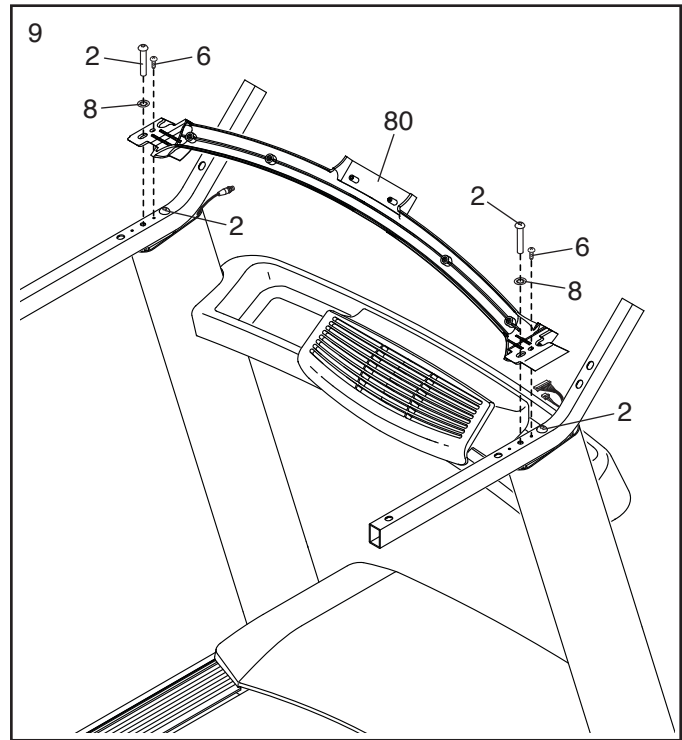

10. With the help of a second person, hold the console assembly (D) near the Handrails (74).

See the inset drawing. Connect the Upright Wire (83) to the console wire (F). **The connectors should slide together easily and snap into place.** If they do not, turn one connector and try again. **IF YOU DO NOT CONNECT THE CONNECTORS PROPERLY, THE CONSOLE MAY BECOME DAMAGED WHEN YOU TURN ON THE POWER.**

Next, connect the two fan wires (B, G). Then, remove any wire ties from the Upright Wire (83) and the fan wires.

Connect the two coaxial cables on the other side (not shown). Insert the excess cable and fan wire into the Upright (84).

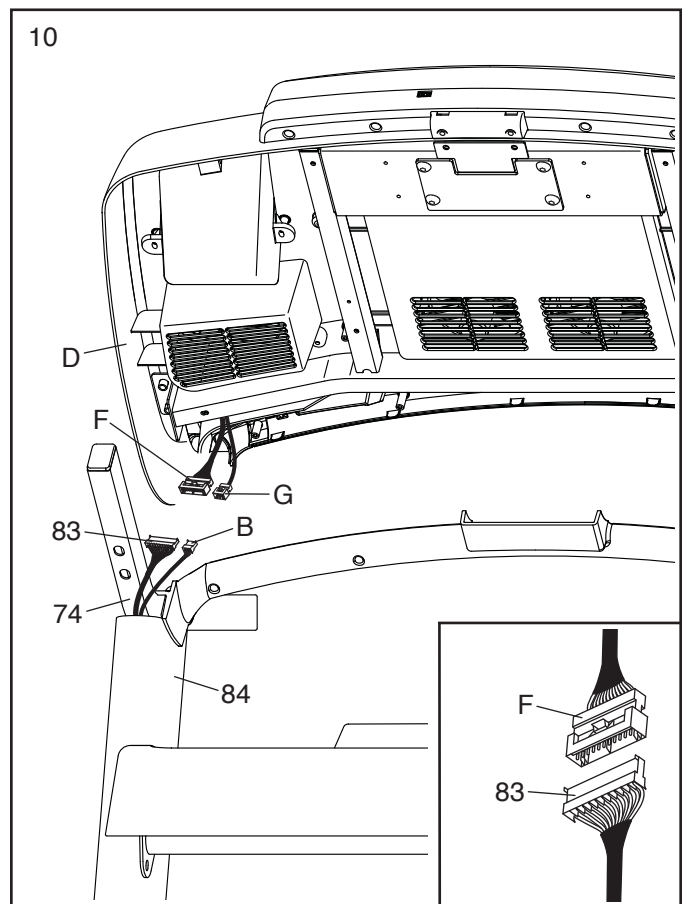

11. Attach the console assembly (D) to the Handrails (74) with four 5/16" x 2" Screws (2) and four 5/16" Star Washers (8); **start all four Screws, and then tighten them. Be careful not to pinch the wires and cables.**

Then, insert the wires and cables upward into the console assembly (D).

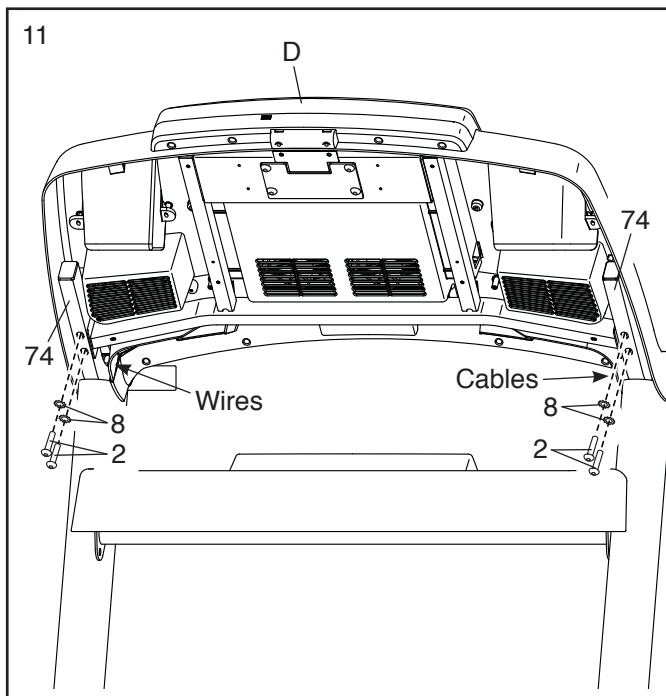

12. Identify the #8 x 3/4" Screws (5). **IMPORTANT: Do not confuse the #8 x 3/4" Screws with the #8 x 3/4" Truss Head Screws (24). The #8 x 3/4" Truss Head Screws have flatter heads.**

Start four #8 x 3/4" Screws (5) into the Pulse Crossbar (80), and then tighten them; **do not overtighten the Screws.**

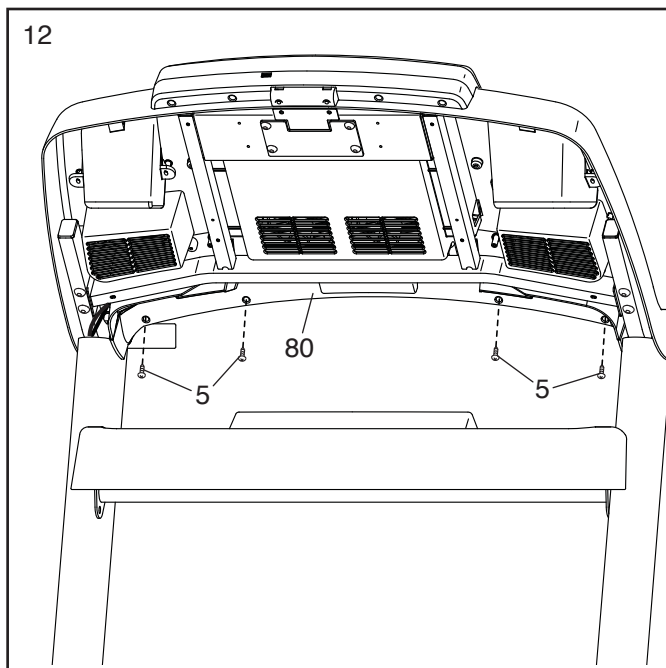

13. Set the Left Handrail Top Cover (73) on the left Handrail (74). Start four #8 x 3/4" Truss Head Screws (24) into the Left Handrail Bottom Cover (75), the left Handrail, and the Left Handrail Top Cover. Slide the Left Handrail Top and Bottom Covers forward against the console assembly (D) as shown; **tighten all four Screws.**

Attach the Right Handrail Top and Bottom Covers (81, 82) to the right Handrail (74) in the same way.

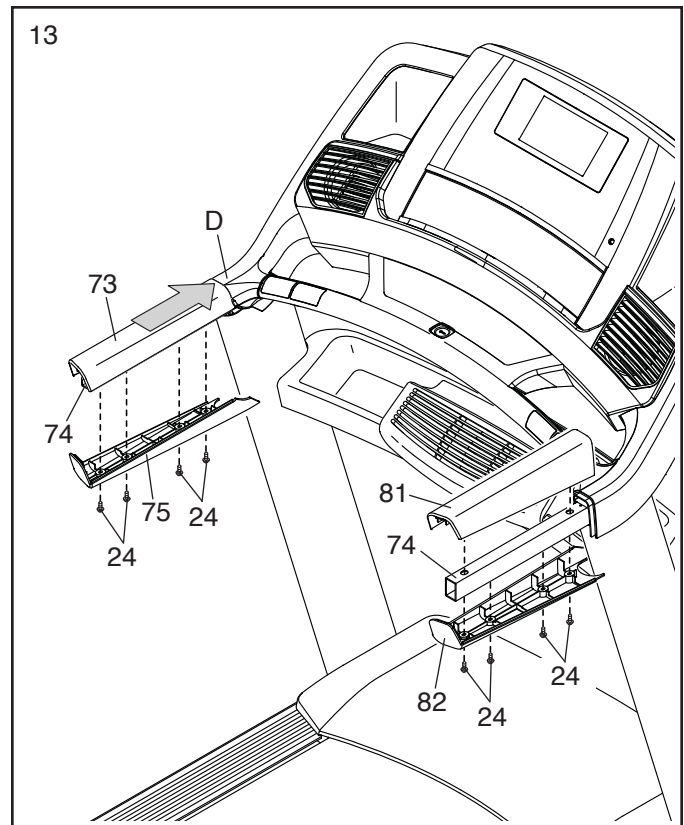

14. Raise the Frame (52) to the position shown. **Have a second person hold the Frame until step 15 is completed.**

Remove the 5/16" Nut (9) and the 5/16" x 1 3/4" Bolt (3) from the bracket on the Uprights (84).

Next, orient the Storage Latch (56) as shown.

Attach the lower end of the Storage Latch (56) to the bracket on the Uprights (84) with the 5/16" x 1 3/4" Bolt (3) and the 5/16" Nut (9).

Then, raise the Storage Latch (56) to a vertical position, and remove the tie (H).

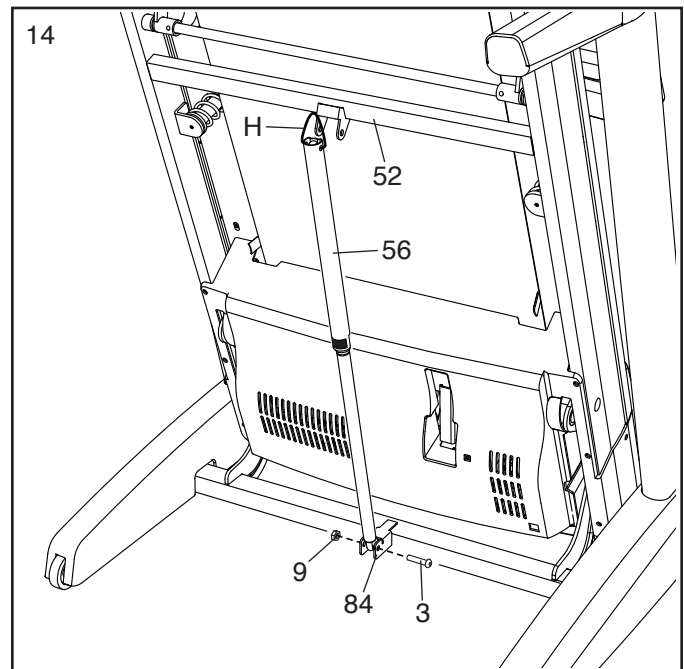

15. Remove the 5/16" Nut (9) and the 5/16" x 2 1/4" Bolt (4) from the bracket on the Frame (52).

Align the upper end of the Storage Latch (56) with the bracket on the Frame (52), and insert the 5/16" x 2 1/4" Bolt (4) through the bracket and the Storage Latch. **This will push a spacer (I) out of the Storage Latch; discard the spacer.**

Next, tighten the 5/16" Nut (9) onto the 5/16" x 2 1/4" Bolt (4). **Do not overtighten the Nut; the Storage Latch (56) must be able to pivot.**

Then, lower the Frame (52) (see HOW TO LOWER THE TREADMILL FOR USE on page 32).

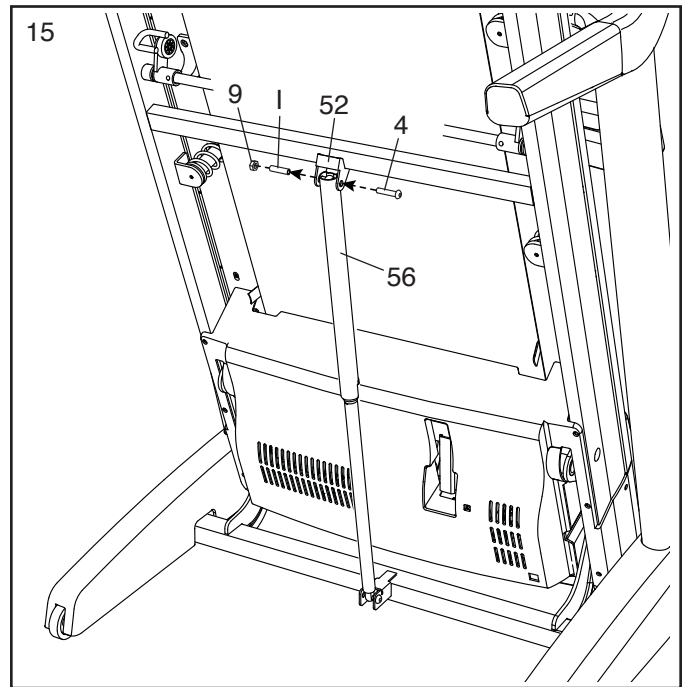

16. Press the two tabs on the Tablet Holder (16) into the slots (J) in the console assembly (D).

Attach the Tablet Holder (16) to the console assembly (D) with four #8 x 5/8" Machine Screws (108). **Note: Start the two top Machine Screws first, and then start the two bottom Machine Screws. Be careful not to overtighten the Machine Screws.**

IMPORTANT: The Tablet Holder (16) is designed for use with most full-size tablets. Do not place any other electronic device or object in the Tablet Holder.

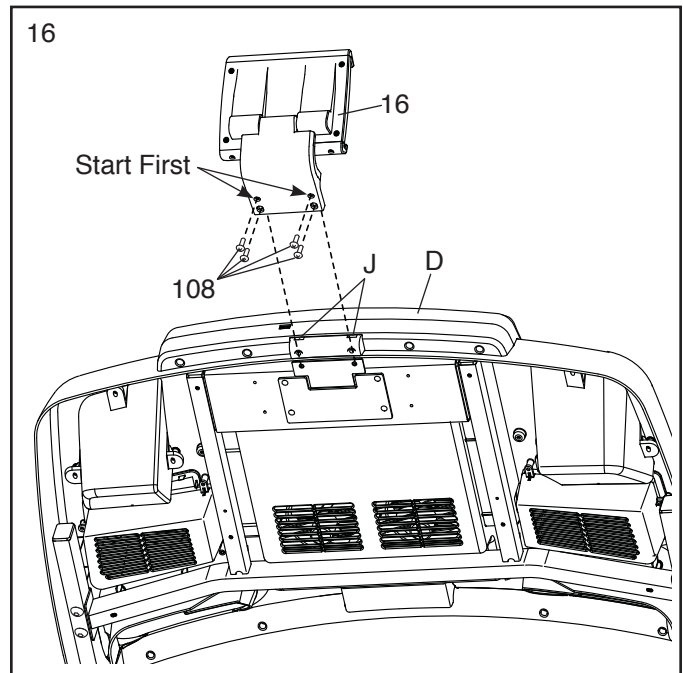

17. **Make sure that all parts are properly tightened before you use the treadmill.** If there are sheets of plastic on the treadmill decals, remove the plastic. To protect the floor or carpet, place a mat under the treadmill. To avoid damage to the console, keep the treadmill out of direct sunlight. Keep the included hex keys in a secure place; one of the hex keys is used to adjust the walking belt (see pages 34 and 35). Note: Extra parts may be included.

THE CHEST HEART RATE MONITOR

HOW TO PUT ON THE HEART RATE MONITOR

If the heart rate monitor looks like the one shown in drawing 1, press the transmitter (A) onto the snap fasteners on the chest strap (B). If the heart rate monitor looks like the one shown in drawing 2, insert the tab (C) on one end of the chest strap (D) into one end of the transmitter (E). Then, press the end of the transmitter under the buckle (F) on the chest strap; the tab should be flush with the transmitter.

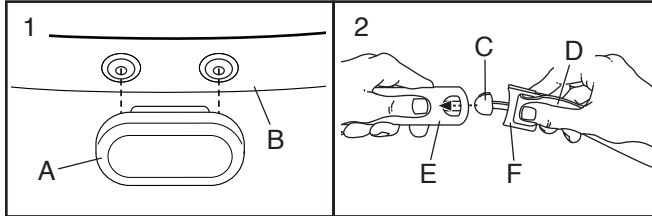

Next, wrap the heart rate monitor around your chest in the location shown; the heart rate monitor must be under your clothes, tight against your skin. Make sure that the logo is right-side-up. Then, attach the other end of the chest strap. Adjust the length of the chest strap, if necessary.

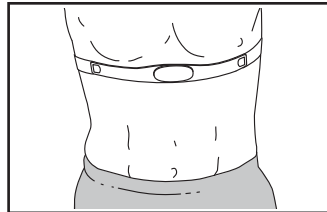

Next, pull the transmitter and the chest strap away from your body a few inches and locate the two electrode areas (G). Using saliva or contact lens solution, wet the electrode areas. Then, return the transmitter and the chest strap to a position against your chest.

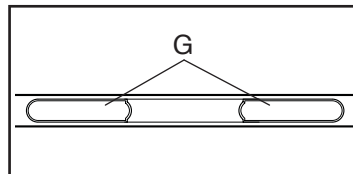

CARE AND MAINTENANCE

- Thoroughly dry the electrode areas with a soft towel after each use. Moisture may keep the heart rate monitor activated, shortening the life of the battery.
- Store the heart rate monitor in a warm, dry place. Do not store the heart rate monitor in a plastic bag or other container that may trap moisture.
- Do not expose the heart rate monitor to direct sunlight for extended periods of time, and do not expose it to temperatures above 122° F (50° C) or below 14° F (-10° C).
- Do not excessively bend or stretch the heart rate monitor when using or storing it.
- To clean the transmitter, use a damp cloth and a small amount of mild soap. Then, wipe the transmitter with a damp cloth and thoroughly dry it with a soft towel. Never use alcohol, abrasives, or chemicals to clean the transmitter. Hand wash and air dry the chest strap.

TROUBLESHOOTING

- If the heart rate monitor does not function when positioned as described at the left, move it slightly lower or higher on your chest.
- If heart rate readings are not displayed until you begin perspiring, re-wet the electrode areas.
- For the console to display heart rate readings, you must be within arm's length of the console.
- If there is a battery cover on the back of the transmitter, replace the battery with a new battery of the same type.
- The heart rate monitor is designed to work with people who have normal heart rhythms. Heart rate reading problems may be caused by medical conditions such as premature ventricular contractions (pvc's), tachycardia bursts, and arrhythmia.
- The operation of the heart rate monitor can be affected by magnetic interference from high power lines or other sources. If you suspect that magnetic interference is causing a problem, try relocating the fitness equipment.

HOW TO USE THE TREADMILL

HOW TO CONNECT THE POWER CORD

Use a Surge Suppressor

Your treadmill, like other electronic equipment, can be damaged by sudden voltage changes in your home's power. Voltage surges, spikes, and noise interference can result from weather conditions or from other appliances being turned on or off. **To decrease the risk of damaging the treadmill, always use a surge suppressor with the treadmill. To purchase a surge suppressor, see precaution 14 on page 3.**

Use only a surge suppressor that is UL 1449 listed as a transient voltage surge suppressor (TVSS). The surge suppressor must have a UL suppressed voltage rating of 400 volts or less and a minimum surge dissipation of 450 joules. The surge suppressor must also be electrically rated for 120 volts AC and 15 amps. There must be a monitoring light on the surge suppressor to indicate whether it is functioning properly. **Failure to use a properly functioning surge suppressor could result in damage to the control system of the treadmill and serious injury to users.**

Plug in the Power Cord

The treadmill must be grounded. If it should malfunction or break down, grounding provides a path of least resistance for electric current to reduce the risk of electric shock. The treadmill power cord has a plug with a grounding pin (see drawing 1 on this page).

⚠ DANGER: Improper connection of the power cord increases the risk of electric shock. Do not modify the plug—if it will not fit an outlet, have a proper outlet installed by a qualified electrician. If you are unsure whether the treadmill is properly grounded, contact a qualified electrician.

Plug the power cord into a surge suppressor, and plug the surge suppressor into an appropriate outlet that is properly installed and grounded in accordance with all local codes and ordinances. **The outlet must be on a**

nominal 120-volt circuit capable of carrying 15 or more amps. To avoid overloading the circuit, do not plug other electrical devices, except for low-power devices such as cell phone chargers, into the surge suppressor or into an outlet on the same circuit. **IMPORTANT: If the treadmill is connected to an AFCI-equipped outlet and your circuit breaker trips repeatedly when the treadmill is used, see the front cover of this manual to purchase an arc filter.**

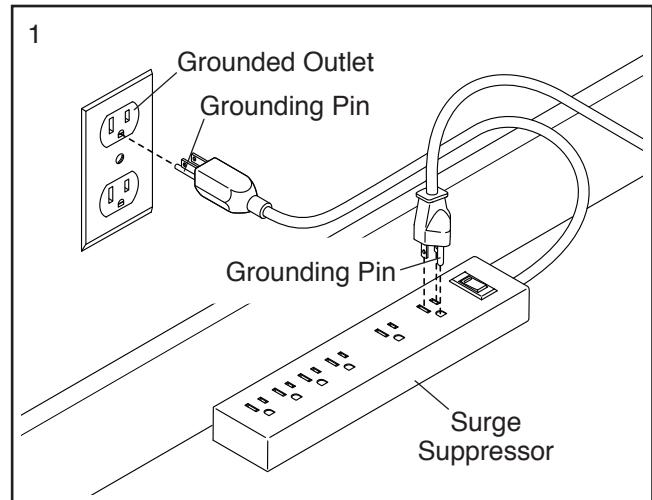

A temporary adapter may be used to connect the surge suppressor to a 2-pole receptacle if a properly grounded outlet is not available.

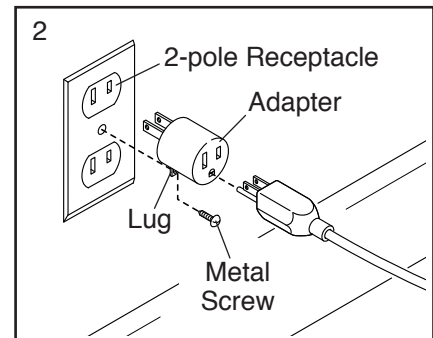

The lug or wire extending from the adapter must be connected with a metal screw to a permanent ground such as a properly grounded outlet box cover. **Some 2-pole receptacle outlet box covers are not grounded. Before using an adapter, contact a qualified electrician to determine whether the outlet box cover is grounded. The temporary adapter should be used only until a properly grounded outlet can be installed by a qualified electrician.**

HOW TO UPGRADE THE CONSOLE

The treadmill console has been preconfigured to operate with a digital TV (see the drawings below). To learn about the features of the console, see page 19. To learn about the features of the digital TV, see the user's manual included with the digital TV. **Note: The row of buttons directly beneath the screen function with the digital TV only.** The basic console has no television capabilities.

To upgrade your console whenever you choose, please see the front cover of this manual.

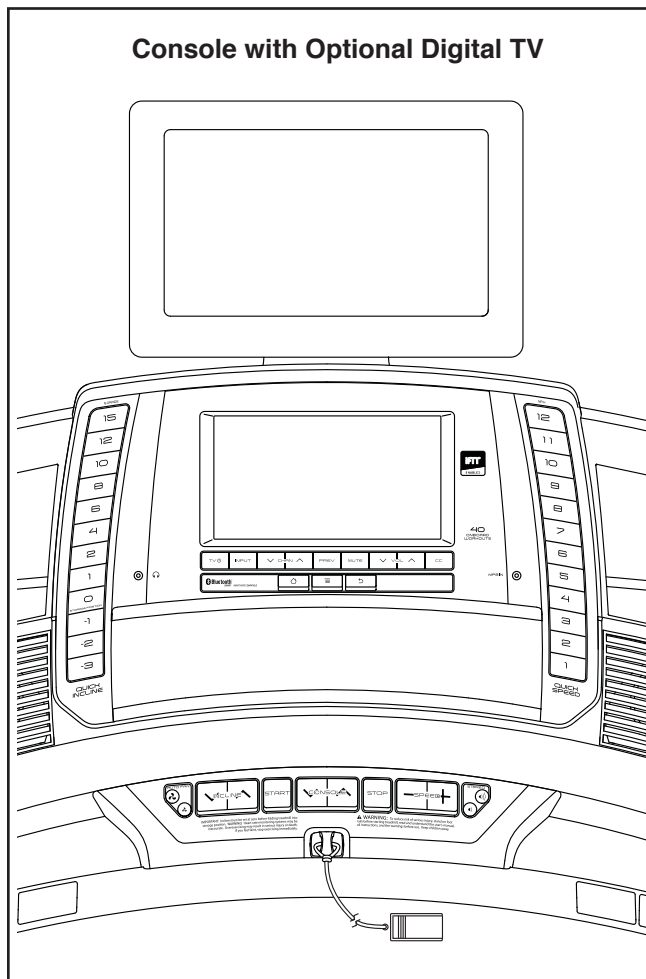
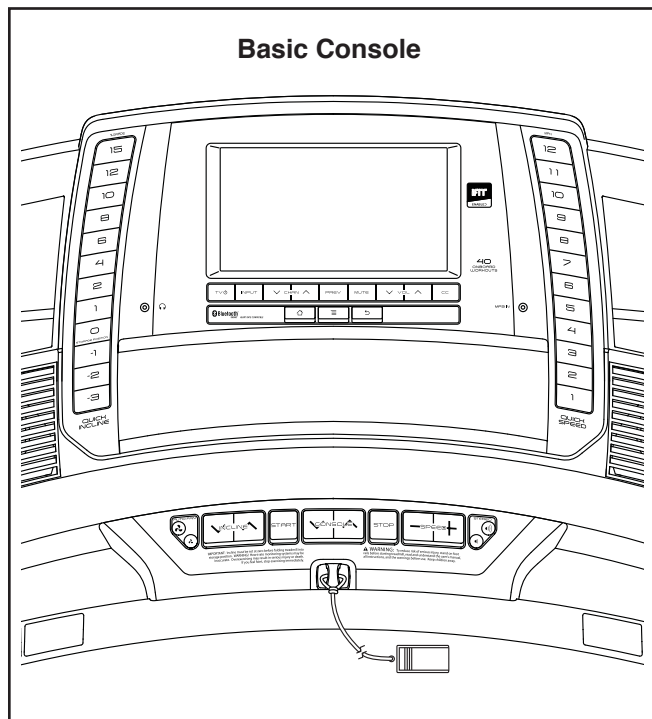

CONSOLE DIAGRAM

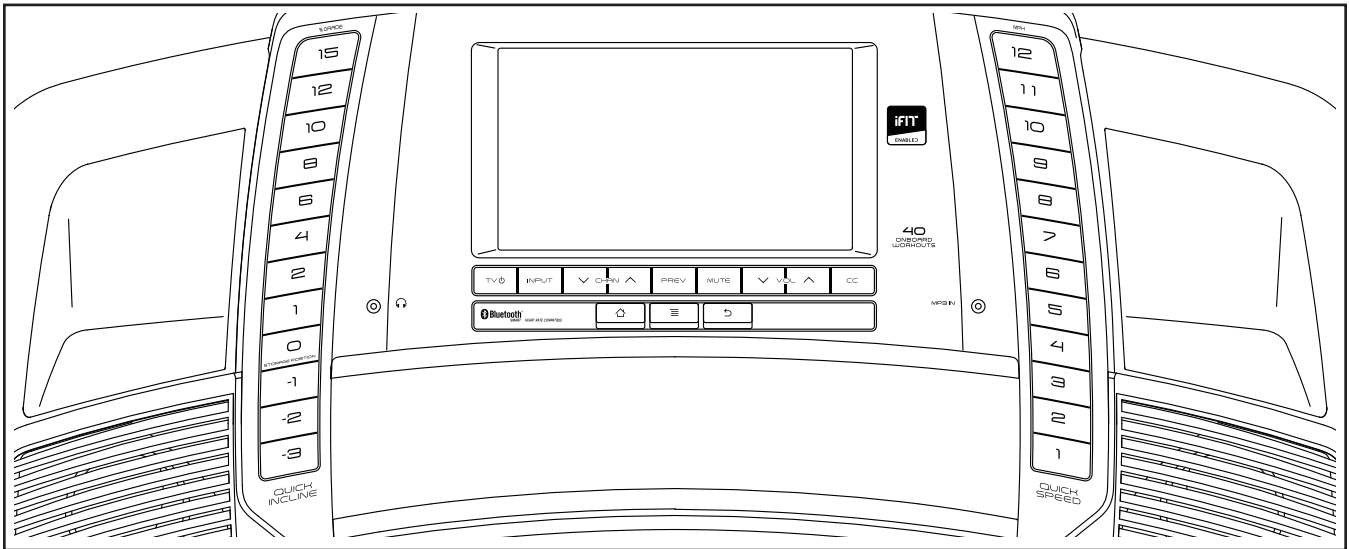

MAKE YOUR FITNESS GOALS A REALITY WITH IFIT.COM

With your new iFit-compatible fitness equipment, you can use an array of features on iFit.com to make your fitness goals a reality:



Run anywhere in the world with customizable Google Maps.



Download training workouts designed to help you reach your personal goals.



Measure your progress by competing against other users in the iFit community.



Upload your workout results to the iFit cloud and track your accomplishments.



Set calorie, time, or distance goals for your workouts.



Watch high-definition videos with simulated workouts.



Choose and download sets of weight-loss workouts.

Go to [iFit.com](https://www.ifit.com) to learn more.

FEATURES OF THE CONSOLE

The advanced treadmill console offers an array of features designed to make your workouts more effective and enjoyable.

When you use the manual mode, you can change the speed and incline of the treadmill with the touch of a button. As you exercise, the console will display instant exercise feedback. You can also measure your heart rate using the handgrip heart rate monitor or the chest heart rate monitor.

In addition, the console features a selection of onboard workouts. Each workout automatically controls the speed and incline of the treadmill as it guides you through an effective exercise session. In addition, you can set a calorie, time, distance, or pace goal.

You can even browse the Internet or listen to your favorite workout music or audio books with the console's sound system while you exercise.

To turn on the power, see page 20. **To learn how to use the touch screen**, see page 20. **To set up the console**, see page 21.

HOW TO TURN ON THE POWER

IMPORTANT: If the treadmill has been exposed to cold temperatures, allow it to warm to room temperature before you turn on the power. If you do not do this, you may damage the console displays or other electrical components.

Plug in the power cord (see page 17). Next, locate the power switch on the treadmill frame near the power cord. Press the power switch into the reset position.

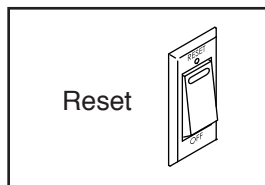

IMPORTANT: The console features a display demo mode, designed to be used if the treadmill is displayed in a store. If the demo mode is turned on, the screen will show a demo presentation after you plug in the power cord and press the power switch into the reset position, before you insert the key. To turn off the demo mode, see step 7 on page 27.

Next, stand on the foot rails of the treadmill. Locate the clip attached to the key, and slide the clip securely onto the waistband of your clothes.

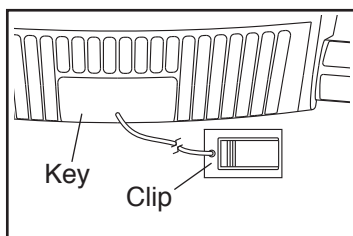

Then, insert the key into the console. **Note:** It may take a minute for the console to be ready for use. **IMPORTANT:** In an emergency, the key can be pulled from the console, causing the walking belt to slow to a stop. Test the clip by carefully taking a few steps backward; if the key is not pulled from the console, adjust the position of the clip.

IMPORTANT: Before you use the treadmill, take the following steps to ensure that the console shows the correct incline level of the treadmill: First, press the incline increase button once. Next, press either the incline decrease button or the lowest Quick Incline button to set the treadmill to its lowest setting. When the frame stops moving, the treadmill is ready for use.

Note: The console can display speed and distance in either miles or kilometers. To find which unit of measurement is selected, see step 4 on page 27. For simplicity, all instructions in this section refer to miles.

HOW TO USE THE TOUCH SCREEN

The console features a tablet with a full-color touch screen. The following information will help you become familiar with the tablet's advanced technology:

- The console functions similarly to other tablets. You can slide or flick your finger against the screen to move certain images on the screen, such as the displays in a workout (see step 5 on page 22). However, you cannot zoom in and out by sliding your fingers on the screen.
- The screen is not pressure sensitive. You do not need to press hard on the screen.
- To type information into a text box, touch the text box to view the keyboard. To use numbers or other characters on the keyboard, touch the ?123 button. To view more characters, touch the Alt button. Touch the Alt button again to return to the number keyboard. To return to the letter keyboard, touch the ABC button. To use a capital character, touch the button with an upward-facing arrow. To use multiple capital characters, touch the arrow button again. To return to the lowercase keyboard, touch the arrow button a third time. To clear the last character, touch the button with a backward-facing arrow and an X.

Use the buttons on the console to navigate the tablet. Press the home button to return to the main menu. Press the settings button to access the settings main menu (see page 27). Press the back button to return to the previous screen.

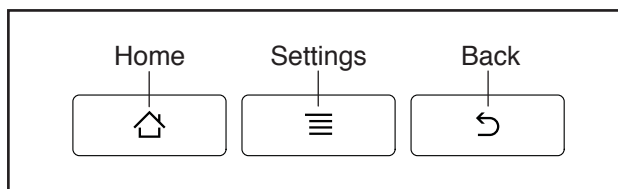

HOW TO SET UP THE CONSOLE

Before using the treadmill for the first time, set up the console.

1. Connect to your wireless network.

Note: In order to access the Internet, download iFit workouts, and use several other features of the console, you must be connected to a wireless network. See HOW TO USE THE WIRELESS NETWORK MODE on page 30 to connect the console to your wireless network.

2. Check for firmware updates.

First, see step 1 on page 27 and step 2 on page 29 and select the maintenance mode. Then, see step 3 on page 29 and check for firmware updates.

3. Calibrate the incline system.

See step 4 on page 29 and calibrate the incline system of the treadmill.

4. Create an iFit account.

Touch the globe button near the lower left corner of the screen and touch the iFit button.

Note: For information about navigating in the browser, see page 29. The browser will open to the iFit.com home page. Follow the prompts on the website to sign up for your iFit membership. If you have an activation code, select the code activation option.

The console is now ready for you to begin working out. The following pages explain the various workouts and other features that the console offers.

To use the manual mode, see this page. **To use an onboard workout**, see page 23. **To use a set-a-goal workout**, see page 24. **To use an iFit workout**, see page 25.

To use the equipment settings mode, see page 27. **To use the sound system**, see page 28. **To use the Internet browser**, see page 29. **To use the maintenance mode**, see page 29. **To use the entertainment mode**, see page 30. **To use the wireless network mode**, see page 30.

IMPORTANT: If there are sheets of plastic on the console, remove the plastic. To prevent damage to the walking platform, wear clean athletic shoes while using the treadmill. The first time you use the treadmill, observe the alignment of the walking belt, and center the walking belt if necessary (see page 34).

HOW TO USE THE MANUAL MODE

1. Insert the key into the console.

See HOW TO TURN ON THE POWER on page 20. **Note: It may take a minute for the console to be ready for use.**

2. Select the main menu.

When you turn on the power, the main menu will appear after the console boots up. Touch the home button in the lower left corner of the screen (not shown here) to return to the main menu at any time.

3. Start the walking belt and adjust the speed.

Touch the Start button on the screen or press the Start button on the console to start the walking belt. You can

also press the Manual button on the console, and then touch the Resume button on the screen.

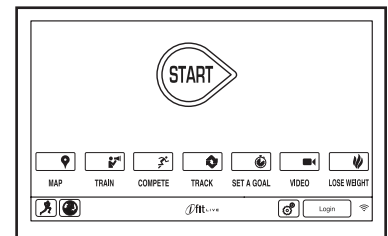

The walking belt will begin to move at 1 mph. As you exercise, change the speed of the walking belt as desired by pressing the Speed increase and decrease buttons. Each time you press one of the buttons, the speed setting will change by 0.1 mph; if you hold down the button, the speed setting will change in increments of 0.5 mph.

If you press one of the Quick Speed buttons, the walking belt will gradually change speed until it reaches the selected speed setting.

To select a speed setting that includes a decimal—such as 3.5 mph—press two 1 Step Speed buttons in succession. For example, to select a speed setting of 3.5 mph, press the 3 button and then immediately press the 5 button. Note: This will not function if the console is set to metric units.

To stop the walking belt, press the Stop button. To restart the walking belt, press the Start button.

4. Change the incline of the treadmill as desired.

To change the incline of the treadmill, press the Incline increase and decrease buttons or one of the Quick Incline buttons. Each time you press one of the buttons, the incline will gradually change until it reaches the selected incline setting.

Note: The first time you adjust the incline, you must first calibrate the incline system (see step 4 on page 29).

5. Monitor your progress with the displays.

The console offers several display modes. The display mode that you select will determine which workout information is shown. To select the desired display mode, simply flick or slide the screen. You can also view additional information by touching the red boxes on the screen.

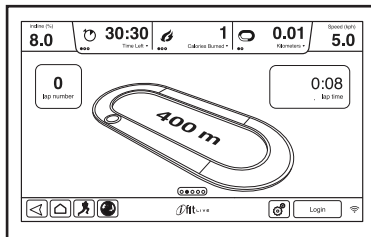

As you walk or run on the treadmill, the screen can show the following workout information:

- The incline level of the treadmill
- The elapsed time
- The time left (Note: The manual mode does not have a time left countdown.)
- The approximate number of calories you have burned
- The approximate number of calories you are burning per hour
- The distance that you have walked or run
- The number of vertical feet you have climbed
- The speed of the walking belt
- A track representing 1/4 mile (400 m)
- Your pace
- Your current lap number
- Your heart rate (see step 6)

6. Measure your heart rate if desired.

Note: If you use the handgrip heart rate monitor and the chest heart rate monitor at the same time, the console will not display your heart rate accurately. For information about the chest heart rate monitor, see page 16. Note: The console is compatible with BLUETOOTH® Smart heart rate monitors.

Before using the handgrip heart rate monitor, remove the sheets of plastic from the metal contacts. In addition, make sure that your hands are clean.

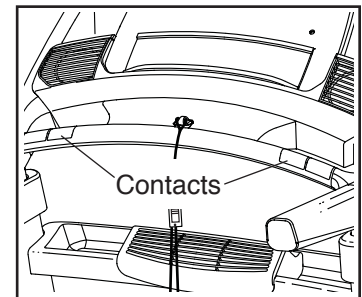

To measure your heart rate, **stand on the foot rails** and hold the contacts with your palms for approximately ten seconds; **avoid moving your hands**. When your pulse is detected, your heart rate will be shown. **For the most accurate heart rate reading, continue to hold the contacts for about 15 seconds.**

7. Turn on the fan if desired.

The fan features several speed settings and an auto mode. When the auto mode is selected, the speed of the fan will automatically increase and decrease as the speed of the walking belt increases and decreases.

Press the small fan button repeatedly to select a fan speed or to turn off the fan. Press the large fan button to select a fan speed or the auto mode.

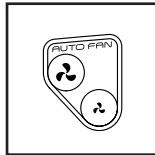

8. When you are finished exercising, remove the key from the console.

Step onto the walking platform and touch the home button or the back button on the screen or press the Stop button on the console. A workout summary will appear on the screen. After you view the workout summary, touch the Finish button to return to the main menu. You may also be able to either save or publish your results using one of the options on the screen. Then, remove the key from the console and put it in a secure place.

When you are finished using the treadmill, press the power switch into the off position and unplug the power cord. **IMPORTANT: If you do not do this, the treadmill's electrical components may wear prematurely.**

HOW TO USE AN ONBOARD WORKOUT

1. Insert the key into the console.

See HOW TO TURN ON THE POWER on page 20.

2. Select an onboard workout.

To select an onboard workout, touch the runner button on the screen.

Then, select the desired workout. The screen will show the name, duration, and distance of the workout. The screen will also show the approximate number of calories you will burn during the workout and a profile of the incline settings of the workout.

3. Start the workout.

Touch the Start Workout button to start the workout. A moment after you touch the button, the walking belt will begin to move. Hold the handrails and begin walking.

Each workout is divided into several segments. One speed setting and one incline setting are programmed for each segment. Note: The same speed setting and/or incline setting may be programmed for consecutive segments.

During the workout, the profile will show your progress. To view the profile, flick or slide the screen. The vertical colored line will indicate the current segment of the workout. The bottom profile represents the incline setting for the current segment. The top profile represents the speed setting for the current segment.

At the end of the first segment of the workout, the treadmill will automatically adjust to the speed and/or incline settings for the next segment.

The workout will continue in this way until the last segment ends. The walking belt will then slow to a stop and a workout summary will appear on the screen. After you view the workout summary, touch the Finish button to return to the main menu. You may also be able to either save or publish your results using one of the options on the screen.

If the speed and/or incline settings are too high or too low at any time during the workout, you can override the settings by pressing the Speed or Incline buttons. **If you press a Speed button**, you can then manually control the speed (see step 3 on page 21). **If you press an Incline button**, you can then manually control the incline (see step 4 on page 22). **To return to the programmed speed and/or incline settings of the workout**, touch the Follow Workout button.

To pause the workout, touch either the back button or the home button in the lower left corner of the screen, or press the Stop button on the console. To continue the workout, touch the Resume button or press the Start button on the console. To end the workout, touch the End Workout button.

Note: The calorie goal is an estimate of the number of calories that you will burn during the workout. The actual number of calories that you burn will depend on various factors such as your weight. In addition, if you manually change the speed or incline of the treadmill during the workout, the number of calories you burn will be affected.

4. Monitor your progress with the displays.

See step 5 on page 22. The screen can also show a profile of the speed and incline settings of the workout.

5. Measure your heart rate if desired.

See step 6 on page 22.

6. Turn on the fan if desired.

See step 7 on page 23.

7. When you are finished exercising, remove the key from the console.

See step 8 on page 23.

HOW TO USE A SET-A-GOAL WORKOUT

1. Insert the key into the console.

See HOW TO TURN ON THE POWER on page 20.

2. Select the main menu.

See step 2 on page 21.

3. Select a set-a-goal workout.

To select a set-a-goal workout, touch the Set A Goal button on the screen.

To select a calorie, time, distance, or pace goal, touch the Calories, Time, Distance, or Pace button.

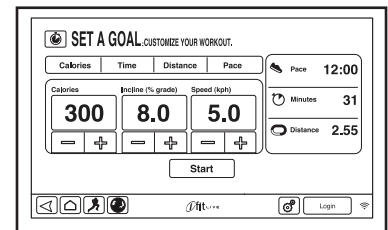

Then, touch the increase and decrease buttons on the screen to set a calorie, time, distance, or pace goal and to set the speed and incline for the workout. The screen will show the duration and distance of the workout, and the approximate number of calories you will burn during the workout.

4. Start the workout.

Touch the Start button to start the workout. A moment after you touch the button, the walking belt will begin to move. Hold the handrails and begin walking.

The workout will function in the same way as the manual mode (see pages 21 to 23).

The workout will continue until you reach the goal that you set. The walking belt will then slow to a stop, and a workout summary will appear on the screen. After you view the workout summary, touch the Finish button to return to the main menu. You may also be able to either save or publish your results using one of the options on the screen.

Note: The calorie goal is an estimate of the number of calories that you will burn during the workout. The actual number of calories that you burn will depend on various factors such as your weight.

5. Monitor your progress with the displays.

See step 5 on page 22.

6. Measure your heart rate if desired.

See step 6 on page 22.

7. Turn on the fan if desired.

See step 7 on page 23.

8. When you are finished exercising, remove the key from the console.

See step 8 on page 23.

HOW TO USE AN IFIT WORKOUT

Note: To use an iFit workout, you must have access to a wireless network (see HOW TO USE THE WIRELESS NETWORK MODE on page 30). An iFit account is also required.

1. Insert the key into the console.

See HOW TO TURN ON THE POWER on page 20.

2. Select the main menu.

See step 2 on page 21.

3. Log in to your iFit account.

If you have not already done so, touch the Login button to log in to your iFit account. The screen will ask for your iFit.com username and password. Enter them and touch the Submit button. Touch the Cancel button to exit the login screen.

4. Select an iFit workout.

To download an iFit workout in your schedule, touch the Map, Train, Video, or Lose Weight button to download the next work-

out of that type in your schedule. Note: You may be able to access demo workouts through these options, even if you do not log in to an iFit account.

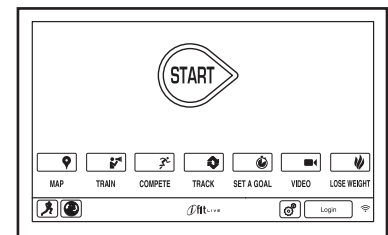

To compete in a race that you have previously scheduled, touch the Compete button. To view your Workout History, touch the Track button. To use a set-a-goal workout, touch the Set A Goal button (see page 24).

To switch users within the account, touch the user button near the lower right corner of the screen.

Before some workouts will download, you must add them to your schedule on iFit.com.

For more information about the iFit workouts, please see www.iFit.com.

When you select an iFit workout, the screen will show the name, duration, and distance of the workout. The screen will also show the approximate number of calories you will burn during the workout. If you select a competition workout, the display will count down to the beginning of the race.

5. Start the workout.

See step 3 on page 23.

During some workouts, an audio coach may guide you through your workout.

6. Monitor your progress with the displays.

See step 5 on page 22. The screen may also show a map of the trail you are walking or running.

During a competition workout, the screen will show the speeds of the iFit users and the distances they have moved. The screen will also show the numbers of seconds that the other iFit users are ahead of you or behind you.

7. Measure your heart rate if desired.

See step 6 on page 22.

8. Turn on the fan if desired.

See step 7 on page 23.

9. When you are finished exercising, remove the key from the console.

See step 8 on page 23.

For more information about the iFit mode, go to www.iFit.com.

HOW TO USE THE EQUIPMENT SETTINGS MODE

1. Select the settings main menu.

Insert the key into the console (see HOW TO TURN ON THE POWER on page 20). Next, select the main menu (see step 2 on page 21). Then, touch the gears button near the lower right corner of the screen to select the settings main menu. You can also press the settings button on the console.

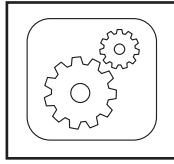

2. Select the equipment settings mode.

In the settings main menu, touch the Equipment Settings button. Note: Slide or flick the screen to scroll up or down through the options if necessary.

3. Select a language.

To select a language, touch the Language button and select the desired language. Then, touch the back button on the screen to return to the equipment settings mode. Note: This feature may not be enabled.

4. Select the unit of measurement.

Touch the US/Metric button to view the selected unit of measurement. Change the unit of measurement, if desired. Then, touch the back button on the screen.

5. Select a timezone.

Touch the Timezone button. Select your local timezone to have the console sync to your local time. Then, touch the back button on the screen.

6. Select an update time.

To select a time for automatic firmware updates, touch the Update Time button and select the desired time. Then, touch the back button on the screen.

IMPORTANT: You must still unplug the power cord after using the treadmill. Set the update time for a time when you normally use the treadmill and will be available to unplug the power cord after an update.

7. Turn on or turn off the display demo mode.

The console features a display demo mode, designed to be used if the treadmill is displayed in a store. While the demo mode is turned on, the console will function normally when you plug in the power cord, press the power switch into the reset position, and insert the key into the console. However, when you remove the key, the screen will show a demo presentation.

To turn on or turn off the display demo mode, first touch the Demo Mode button. Next, touch the On checkbox or the Off checkbox. Then, touch the back button on the screen.

8. Enable or disable the Internet browser.

To enable or disable the Internet browser, first touch the Browser button. Next, touch the Enable checkbox or the Disable checkbox. Then, touch the back button on the screen.

9. Enable or disable the street view.

During some workouts, the screen may show a map. To enable or disable the street view feature of the maps, first touch the Street View button. Next, touch the Enable checkbox or the Disable checkbox. Then, touch the back button on the screen.

10. Enable or disable the key.

Note: This feature may not be enabled on your treadmill.

You can disable the key so that the treadmill does not require the use of the key, if desired. Touch the Safety Key button. To disable the key, touch the Disable checkbox. **CAUTION: Read the safety warning on the screen before disabling the key.** To enable the key again, touch the Enable checkbox.

11. Enable or disable a passcode.

The console features a child-safety passcode, designed to prevent unauthorized users from using the treadmill.

Touch the Passcode button. To enable a passcode, touch the Enable checkbox. Then, enter a 4-digit passcode of your choice. Touch Save to use this passcode. Touch Cancel to return to the equipment settings mode and not use a passcode. To disable the passcode, touch the Disable checkbox.

Note: If a passcode is enabled, the console will regularly ask for you to enter the passcode. The console will remain locked until the correct passcode is entered. **IMPORTANT: If you forget your passcode, enter the following master passcode to unlock the console: 1985.**

12. Set a safety screen timeout.

The console features an automatic screen reset; if no buttons are touched or pressed and the walking belt does not move for a set amount of time, the console will automatically reset.

To set the amount of time the console will wait before it automatically resets, touch the Safety Screen Timeout button to view a list of times. Then, select the amount of time desired. Touch the back button on the screen.

13. Exit the equipment settings mode.

To exit the equipment settings mode, touch the back button on the screen.

HOW TO USE THE SOUND SYSTEM

To play music or audio books through the console sound system while you exercise, plug a 3.5 mm male to 3.5 mm male audio cable (not included) into the jack on the console and into a jack on your MP3 player, CD player, or other personal audio player; **make sure that the audio cable is fully plugged in.** Note: To purchase an audio cable, see your local electronics store.

Next, press the play button on your personal audio player. Adjust the volume level using the volume increase and decrease buttons on the console or the volume control on your personal audio player.

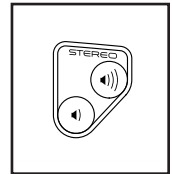

If you are using a personal CD player and the CD skips, set the CD player on the floor or another flat surface instead of on the console.

HOW TO USE THE INTERNET BROWSER

Note: To use the browser, you must have access to a wireless network including an 802.11b/g/n router with SSID broadcast enabled (hidden networks are not supported).

To open the browser, touch the globe button near the lower left corner of the screen. Then, select a website.

To navigate the Internet browser, touch the Back, Refresh, and Forward buttons on the screen. To exit the Internet browser, touch the Return button on the screen.

To use the keyboard, see HOW TO USE THE TOUCH SCREEN on page 20.

To enter a different web address in the URL bar, first, slide your finger down the screen to view the URL bar, if necessary. Then, touch the URL bar, use the keyboard to enter the address, and touch the Go button.

Note: While you are using the browser, the speed, incline, fan, and volume buttons will still function, but the workout buttons will not function.

Note: If you have questions after following these instructions, go to support.iFit.com for assistance.

HOW TO USE THE MAINTENANCE MODE

1. Select the settings main menu.

See step 1 on page 27.

2. Select the maintenance mode.

In the settings main menu, touch the Maintenance button to enter the maintenance mode.

The maintenance mode main screen will show information about the model and version of the treadmill.

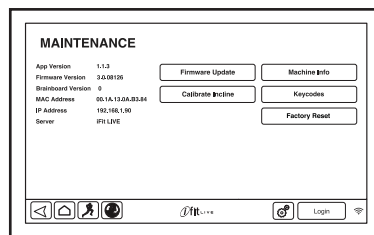

3. Update the console firmware.

For the best results, regularly check for firmware updates.

Touch the Firmware Update button to check for firmware updates using your wireless network. The update will begin automatically.

To avoid damaging the treadmill, do not turn off the power or remove the key while the firmware is being updated.

The screen will show the progress of the update. When the update is complete, the treadmill will turn off and then turn back on. If it does not, press the power switch into the off position. Wait for several seconds, and then press the power switch into the reset position. Note: It may take a few minutes for the console to be ready for use.

Note: Occasionally, a firmware update may cause your console to function slightly differently. These updates are always designed to improve your exercise experience.

4. Calibrate the incline system of the treadmill.

Touch the Calibrate Incline button. Then, touch the Begin button to calibrate the incline system. The treadmill will automatically rise to the maximum incline level, lower to the minimum incline level, and then return to the starting position. This will calibrate the incline system. Touch the Cancel button to return to the maintenance mode. When the incline system is calibrated, touch the Finish button.

IMPORTANT: Keep pets, feet, and other objects away from the treadmill while the incline system is calibrating. In an emergency, pull the key from the console to stop the incline calibration.

5. View machine information.

Touch the Machine Info button to view information about your treadmill. After you view the information, touch the back button on the screen.

6. Find keycodes.

The Keycodes button is intended to be used by service technicians to identify whether a certain button is working correctly.

7. Exit the maintenance mode.

To exit the maintenance mode, touch the back button on the screen.

HOW TO USE THE ENTERTAINMENT MODE

The console features an entertainment mode that allows you to control the optional digital TV. If you purchase the digital TV, please see the manual included with the digital TV to learn how to use the entertainment mode to set up the digital TV.

HOW TO USE THE WIRELESS NETWORK MODE

The console features a wireless network mode that allows you to set up a wireless network connection.

1. Select the settings main menu.

See step 1 on page 27.

2. Select the wireless network mode.

In the settings main menu, touch the Wireless Network button to enter the wireless network mode.

3. Enable Wi-Fi.

Make sure that the Wi-Fi checkbox is marked with a green checkmark. If it is not, touch the Wi-Fi menu option once and wait for a few seconds. The console will search for available wireless networks.

4. Set up and manage a wireless network connection.

When Wi-Fi is enabled, the screen will show a list of available networks. Note: It may take several seconds for the list of wireless networks to appear.

Make sure that the checkbox on the Network notification menu option is marked with a green checkmark to have the console notify you when a wireless network is within range and available.

Note: You must have your own wireless network and an 802.11b/g/n router with SSID broadcast enabled (hidden networks are not supported).

When a list of networks appears, touch the desired network. Note: You will need to know your network name (SSID). If your network has a password, you will also need to know the password.

An information box will ask if you want to connect to the wireless network. Touch the Connect button to connect to the network or touch the Cancel button to return to the list of networks. If the network has a password, touch the password entry box. A keyboard will appear on the screen. To view the password as you type it, touch the Show Password checkbox.

To use the keyboard, see HOW TO USE THE TOUCH SCREEN on page 20.

When the console is connected to your wireless network, the WiFi menu option at the top of the screen will display the word CONNECTED. Then, touch the back button on the screen to return to the wireless network mode.

To disconnect from a wireless network, select the wireless network and then touch the Forget button.

If you are having problems connecting to an encrypted network, make sure that your password is correct. Note: Passwords are case-sensitive.

Note: The iFit mode supports unsecured and secured (WEP, WPA, and WPA2) encryption. A broadband connection is recommended; performance depends on connection speed.

Note: If you have questions after following these instructions, go to support.iFit.com for assistance.

5. Exit the wireless network mode.

To exit the wireless network mode, touch the back button on the screen.

HOW TO USE THE TABLET HOLDER

IMPORTANT: The tablet holder is designed for use with most full-size tablets. Do not place any other electronic device or object in the tablet holder.

To insert a tablet into the tablet holder, set the bottom edge of the tablet in the tray. Then, pull the clip over the top edge of the tablet. **Make sure that the tablet is firmly secured in the tablet holder.** Reverse these actions to remove the tablet from the tablet holder.

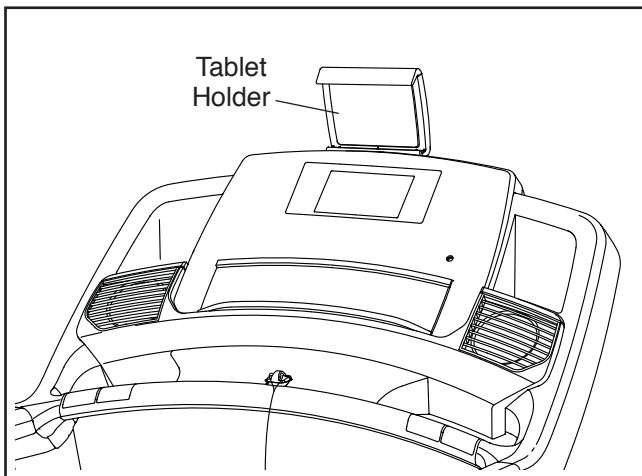

HOW TO ADJUST THE CUSHIONING SYSTEM

The treadmill features a cushioning system that reduces the impact as you walk or run on the treadmill.

Remove the key from the console and unplug the power cord.

For a more firm walking platform, turn the cushion knob a half turn counterclockwise until you feel it lock into place. **For a less firm walking platform,** turn the cushion knob a half turn clockwise until you feel it lock into place. **Note: The faster you run on the treadmill, or the more you weigh, the firmer the walking platform should be.**

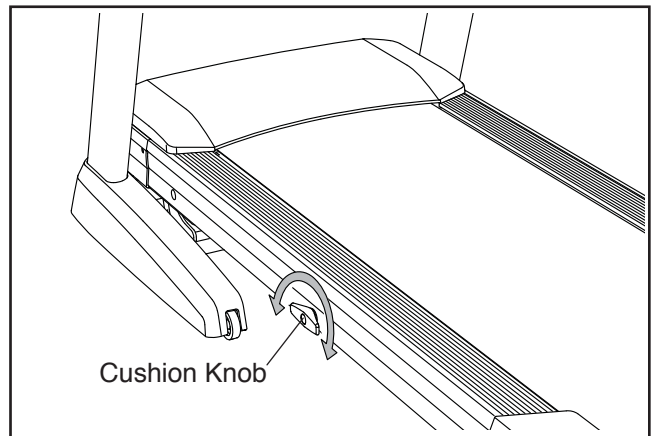

HOW TO FOLD AND MOVE THE TREADMILL

HOW TO FOLD THE TREADMILL

To avoid damaging the treadmill, adjust the incline to zero before you fold the treadmill. Then, remove the key and unplug the power cord. **CAUTION:** You must be able to safely lift 45 lbs. (20 kg) to raise, lower, or move the treadmill.

1. Hold the metal frame firmly in the location shown by the arrow below. **CAUTION:** Do not hold the frame by the plastic foot rails. Bend your legs and keep your back straight.

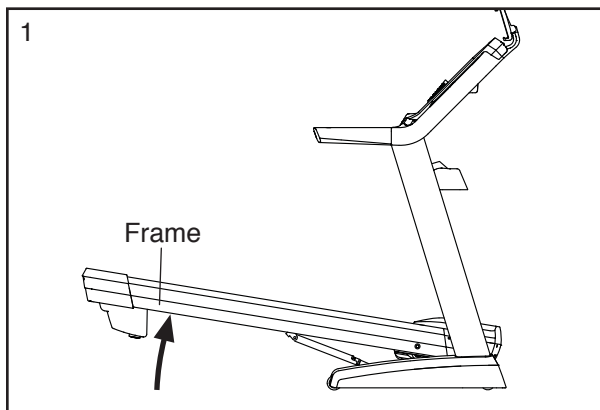

2. Raise the frame until the storage latch locks in the storage position. **CAUTION:** Make sure that the storage latch locks.

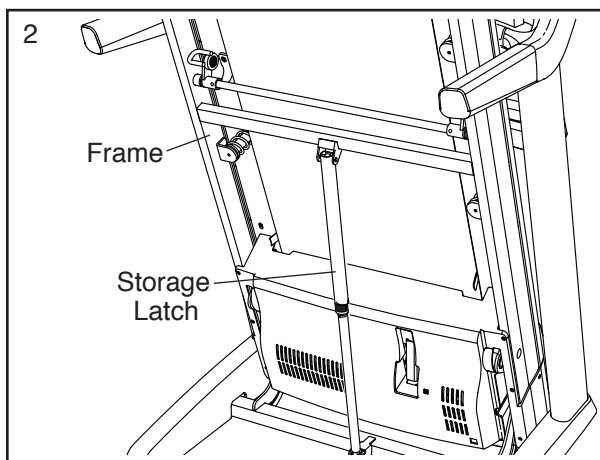

To protect the floor or carpet, place a mat under the treadmill. Keep the treadmill out of direct sunlight. Do not leave the treadmill in the storage position in temperatures above 85° F (30° C).

HOW TO MOVE THE TREADMILL

Before moving the treadmill, fold it as described at the left. **CAUTION:** Make sure that the storage latch is locked in the storage position. Moving the treadmill may require two people.

1. Hold the frame and one of the handrails, and place one foot against a wheel.

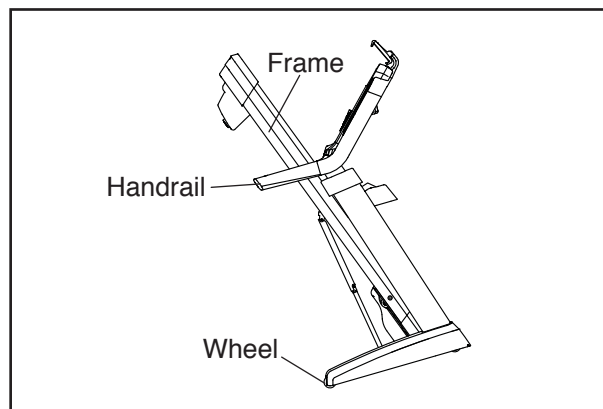

2. Pull back on the handrail until the treadmill will roll on the wheels, and carefully move it to the desired location. **CAUTION:** Do not move the treadmill without tipping it back, do not pull on the frame, and do not move the treadmill over an uneven surface.
3. Place one foot against a wheel, and carefully lower the treadmill.

HOW TO LOWER THE TREADMILL FOR USE

1. Push the upper end of the frame forward, and gently press the upper part of the storage latch with your foot at the same time.
2. While pressing the storage latch with your foot, pull the upper end of the frame toward yourself.
3. Step back and let the frame lower to the floor.

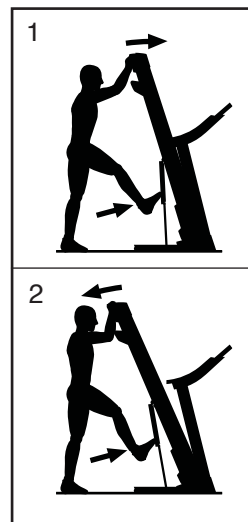

MAINTENANCE AND TROUBLESHOOTING

MAINTENANCE

Regular maintenance is important for optimal performance and to reduce wear. Inspect and properly tighten all parts each time the treadmill is used.

Regularly clean the treadmill and keep the walking belt clean and dry. First, **press the power switch into the off position and unplug the power cord.** Wipe exterior parts of the treadmill with a damp cloth and a small amount of mild soap. **IMPORTANT: Do not spray liquids directly onto the treadmill. To avoid damage to the console, keep liquids away from the console.** Then, thoroughly dry the treadmill with a soft towel.

TROUBLESHOOTING

Most treadmill problems can be solved by following the simple steps below. Find the symptom that applies, and follow the steps listed. If further assistance is needed, see the front cover of this manual.

SYMPTOM: The power does not turn on

- Make sure that the power cord is plugged into a surge suppressor, and that the surge suppressor is plugged into a properly grounded outlet (see page 17). Use only a surge suppressor that meets all of the specifications described on page 17. **IMPORTANT: If the treadmill is connected to an AFCI-equipped outlet and your circuit breaker trips repeatedly when the treadmill is used, see the front cover of this manual to purchase an arc filter.**
- After the power cord has been plugged in, make sure that the key is inserted into the console.

- Check the power switch located on the treadmill frame near the power cord. If the switch protrudes as shown, the switch has tripped. To reset the power switch, wait for five minutes and then press the switch back in.

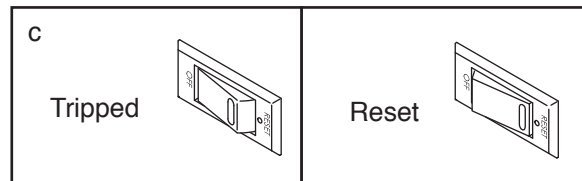

SYMPTOM: The power turns off during use

- Check the power switch (see the drawing above). If the switch has tripped, wait for five minutes and then press the switch back in.
- Make sure that the power cord is plugged in. If the power cord is plugged in, unplug it, wait for five minutes, and then plug it back in.
- Remove the key from the console, and then reinsert it.
- If the treadmill still will not run, please see the front cover of this manual.

SYMPTOM: The console displays remain lit when you remove the key from the console

- The console features a display demo mode, designed to be used if the treadmill is displayed in a store. If the displays remain lit when you remove the key, the demo mode is turned on. To turn off the demo mode, hold down the Stop button for a few seconds. If the displays are still lit, see step 7 on page 27 to turn off the demo mode.

SYMPTOM: The incline of the treadmill does not change correctly

- a. Calibrate the incline system (see step 4 on page 29).

SYMPTOM: The walking belt slows when walked on

- a. Use only a surge suppressor that meets all of the specifications described on page 17.
- b. If the walking belt is overtightened, treadmill performance may decrease and the walking belt may become damaged. Remove the key and **UNPLUG THE POWER CORD**. Using the hex key, turn both idler roller screws counterclockwise, 1/4 of a turn. When the walking belt is properly tightened, you should be able to lift each edge of the walking belt 2 to 3 in. (5 to 7 cm) off the walking platform. Be careful to keep the walking belt centered. Then, plug in the power cord, insert the key, and run the treadmill for a few minutes. Repeat until the walking belt is properly tightened.

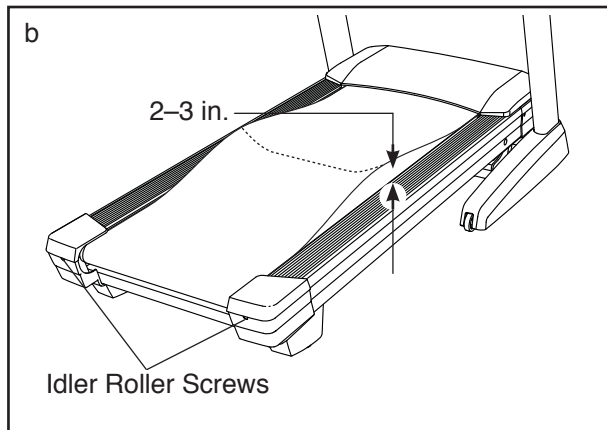

- c. Your treadmill features a walking belt coated with high-performance lubricant. **IMPORTANT: Never apply silicone spray or other substances to the walking belt or the walking platform unless instructed to do so by an authorized service representative. Such substances may deteriorate the walking belt and cause excessive wear.** If you suspect that the walking belt needs more lubricant, see the front cover of this manual.
- d. If the walking belt still slows when walked on, see the front cover of this manual.

SYMPTOM: The walking belt is off-center or slips when walked on

- a. **If the walking belt is off-center**, first remove the key and **UNPLUG THE POWER CORD**. **If the walking belt has shifted to the left**, use the hex key to turn the left idler roller screw clockwise 1/2 of a turn; **if the walking belt has shifted to the right**, turn the left idler roller screw counterclockwise 1/2 of a turn. Be careful not to overtighten the walking belt. Then, plug in the power cord, insert the key, and run the treadmill for a few minutes. Repeat until the walking belt is centered.

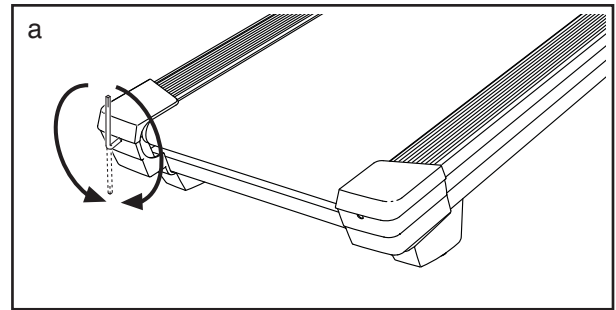

- b. **If the walking belt slips when walked on**, first remove the key and **UNPLUG THE POWER CORD**. Using the hex key, turn both idler roller screws clockwise, 1/4 of a turn. When the walking belt is correctly tightened, you should be able to lift each edge of the walking belt 2 to 3 in. (5 to 7 cm) off the walking platform. Be careful to keep the walking belt centered. Then, plug in the power cord, insert the key, and carefully walk on the treadmill for a few minutes. Repeat until the walking belt is properly tightened.

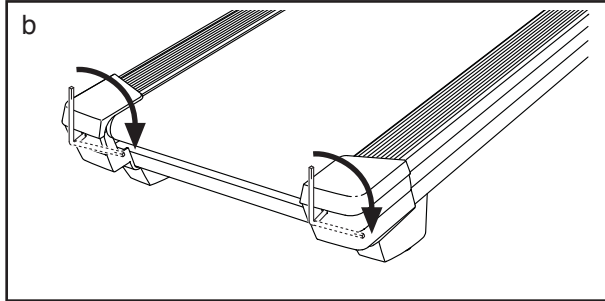

SYMPTOM: The tablet holder does not stay in place

- a. Rotate the tablet holder backwards. Then, tighten the indicated screw slightly until the tablet holder stays in place when it is rotated to the desired position.

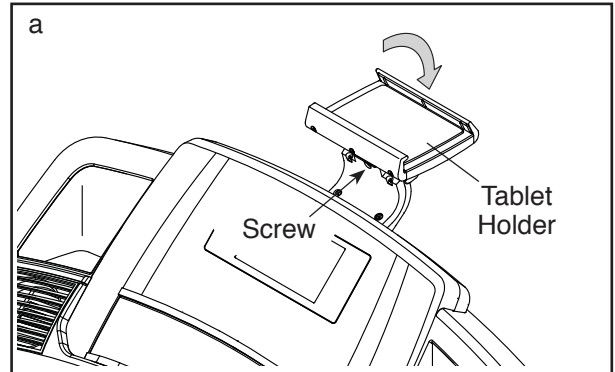

EXERCISE GUIDELINES

⚠️ WARNING: Before beginning this or any exercise program, consult your physician. This is especially important for persons over age 35 or persons with pre-existing health problems.

The heart rate monitor is not a medical device. Various factors may affect the accuracy of heart rate readings. The heart rate monitor is intended only as an exercise aid in determining heart rate trends in general.

These guidelines will help you to plan your exercise program. For detailed exercise information, obtain a reputable book or consult your physician. Remember, proper nutrition and adequate rest are essential for successful results.

EXERCISE INTENSITY

Whether your goal is to burn fat or to strengthen your cardiovascular system, exercising at the proper intensity is the key to achieving results. You can use your heart rate as a guide to find the proper intensity level. The chart below shows recommended heart rates for fat burning and aerobic exercise.

165	155	145	140	130	125	115	♥♥
145	138	130	125	118	110	103	♥
125	120	115	110	105	95	90	♥
<hr/>							
20	30	40	50	60	70	80	

To find the proper intensity level, find your age at the bottom of the chart (ages are rounded off to the nearest ten years). The three numbers listed above your age define your “training zone.” The lowest number is the heart rate for fat burning, the middle number is the heart rate for maximum fat burning, and the highest number is the heart rate for aerobic exercise.

Burning Fat—To burn fat effectively, you must exercise at a low intensity level for a sustained period of time. During the first few minutes of exercise, your body uses carbohydrate calories for energy. Only after the first few minutes of exercise does your body begin to use stored fat calories for energy. If your goal is to burn fat, adjust the intensity of your exercise until your heart rate is near the lowest number in your training zone. For maximum fat burning, exercise with your heart rate near the middle number in your training zone.

Aerobic Exercise—If your goal is to strengthen your cardiovascular system, you must perform aerobic exercise, which is activity that requires large amounts of oxygen for prolonged periods of time. For aerobic exercise, adjust the intensity of your exercise until your heart rate is near the highest number in your training zone.

WORKOUT GUIDELINES

Warming Up—Start with 5 to 10 minutes of stretching and light exercise. A warm-up increases your body temperature, heart rate, and circulation in preparation for exercise.

Training Zone Exercise—Exercise for 20 to 30 minutes with your heart rate in your training zone. (During the first few weeks of your exercise program, do not keep your heart rate in your training zone for longer than 20 minutes.) Breathe regularly and deeply as you exercise; never hold your breath.

Cooling Down—Finish with 5 to 10 minutes of stretching. Stretching increases the flexibility of your muscles and helps to prevent post-exercise problems.

EXERCISE FREQUENCY

To maintain or improve your condition, complete three workouts each week, with at least one day of rest between workouts. After a few months of regular exercise, you may complete up to five workouts each week, if desired. Remember, the key to success is to make exercise a regular and enjoyable part of your everyday life.

SUGGESTED STRETCHES

The correct form for several basic stretches is shown at the right. Move slowly as you stretch—never bounce.

1. Toe Touch Stretch

Stand with your knees bent slightly and slowly bend forward from your hips. Allow your back and shoulders to relax as you reach down toward your toes as far as possible. Hold for 15 counts, then relax. Repeat 3 times. Stretches: Hamstrings, back of knees and back.

2. Hamstring Stretch

Sit with one leg extended. Bring the sole of the opposite foot toward you and rest it against the inner thigh of your extended leg. Reach toward your toes as far as possible. Hold for 15 counts, then relax. Repeat 3 times for each leg. Stretches: Hamstrings, lower back and groin.

3. Calf/Achilles Stretch

With one leg in front of the other, reach forward and place your hands against a wall. Keep your back leg straight and your back foot flat on the floor. Bend your front leg, lean forward and move your hips toward the wall. Hold for 15 counts, then relax. Repeat 3 times for each leg. To cause further stretching of the achilles tendons, bend your back leg as well. Stretches: Calves, achilles tendons and ankles.

4. Quadriceps Stretch

With one hand against a wall for balance, reach back and grasp one foot with your other hand. Bring your heel as close to your buttocks as possible. Hold for 15 counts, then relax. Repeat 3 times for each leg. Stretches: Quadriceps and hip muscles.

5. Inner Thigh Stretch

Sit with the soles of your feet together and your knees outward. Pull your feet toward your groin area as far as possible. Hold for 15 counts, then relax. Repeat 3 times. Stretches: Quadriceps and hip muscles.

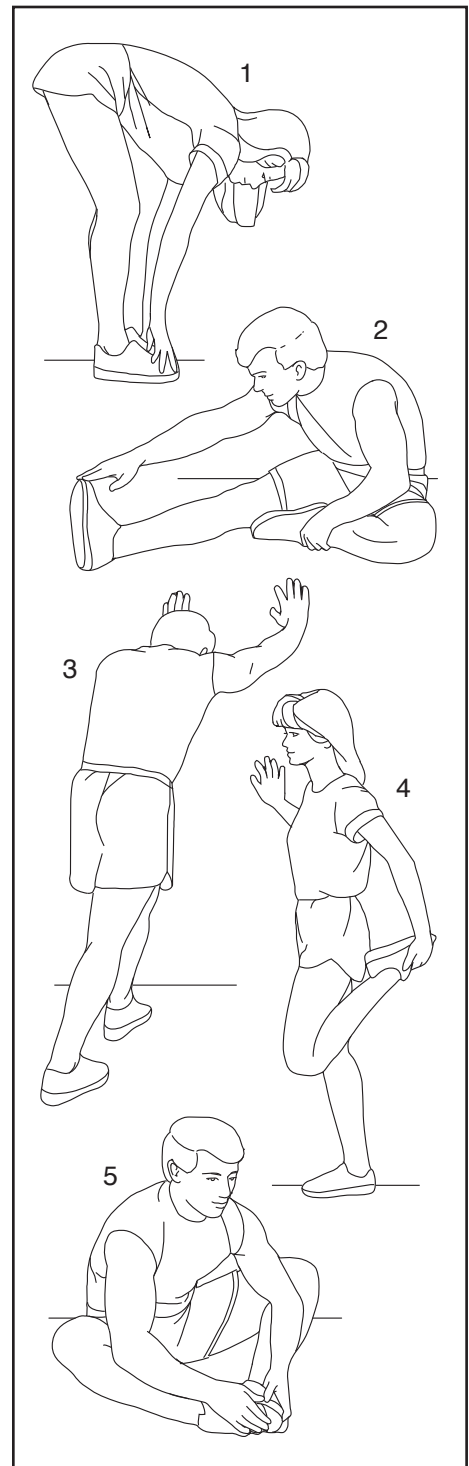

PART LIST

Model No. NTL17215.0 R1015A

Key No.	Qty.	Description	Key No.	Qty.	Description
1	12	5/16" x 3/4" Screw	51	1	Drive Roller/Pulley
2	8	5/16" x 2" Screw	52	1	Frame
3	1	5/16" x 1 3/4" Bolt	53	4	Tie
4	1	5/16" x 2 1/4" Bolt	54	1	Drive Motor
5	65	#8 x 3/4" Screw	55	1	Motor Belt
6	2	#10 x 3/4" Screw	56	1	Storage Latch
7	1	#8 x 1/2" Silver Screw	57	1	Right Frame Cover
8	8	5/16" Star Washer	58	1	Power Supply Plate
9	6	5/16" Nut	59	1	Idler Roller
10	8	#8 x 3/4" Tek Screw	60	1	Left Rear Cap
11	38	#8 x 1/2" Screw	61	1	Right Rear Cap
12	3	1/4" x 2 1/2" Screw	62	1	Motor Hood
13	6	#8 x 1/2" Machine Screw	63	2	Incline Frame Spacer
14	1	3/8" x 1 1/2" Bolt	64	2	Frame Spacer
15	1	3/8" x 2" Bolt	65	1	Incline Frame
16	1	Tablet Holder	66	1	Incline Motor
17	2	#8 x 1 3/4" Screw	67	2	Incline Motor Spacer
18	4	#8 Belt Guide Screw	68	2	Hood Mount
19	2	5/16" Motor Bolt	69	1	Power Cord
20	4	5/16" x 1 3/4" Screw	70	1	Power Cord Grommet
21	4	1/4" x 1 1/4" Screw	71	1	Power Switch
22	2	3/8" x 1 3/4" Bolt	72	1	Belly Pan
23	4	Base Pad	73	1	Left Handrail Top Cover
24	8	#8 x 3/4" Truss Head Screw	74	2	Handrail
25	1	Tray Fan Grill	75	1	Left Handrail Bottom Cover
26	2	1/2" x 2" Bolt	76	1	Upright Crossbar
27	4	Rubber Cushion	77	2	Console Frame Cap
28	2	3/8" x 1" Screw	78	1	Upright Coaxial Cable
29	8	#6 x 1/2" Screw	79	1	Tray
30	4	1/4" x 3/4" Screw	80	1	Pulse Crossbar
31	4	5/16" Flat Washer	81	1	Right Handrail Top Cover
32	8	#8 x 3/8" Screw	82	1	Right Handrail Bottom Cover
33	3	1/4" x 1/2" Screw	83	1	Upright Wire
34	2	1/2" Nut	84	1	Upright
35	6	3/8" Nut	85	3	Caution Decal
36	5	Hood Clip	86	1	Upright Grommet
37	4	Cushion	87	1	Wire Cover
38	1	Warning Decal	88	2	3/8" Flat Washer
39	1	Walking Platform	89	1	Left Upright Cover
40	1	Walking Belt	90	1	Right Upright Cover
41	1	Left Foot Rail	91	1	Right Extension Leg
42	1	Right Foot Rail	92	2	Rear Wheel
43	2	Belt Guide	93	1	Left Extension Leg
44	1	Left Frame Cover	94	1	Left Tray
45	1	Power Supply	95	2	Fan
46	4	Standoff	96	1	Console
47	2	Cushion Rod Bushing	97	4	3/8" Plastic Bushing
48	1	Controller	98	2	1/2" Plastic Bushing
49	2	#8 Star Washer	99	2	Speaker
50	1	Controller Bracket	100	1	Console Base

Key No.	Qty.	Description	Key No.	Qty.	Description
101	1	Right Tray	115	2	Cushion Rod Bracket
102	2	1/2" Thrust Washer	116	1	Cushion Rod
103	1	Controller Clamp	117	2	Cushion Wheel
104	1	Key/Clip	118	4	Cushion Plate
105	2	Console Frame Cap	119	4	Cushion Spring
106	1	Console Frame	120	1	Left Rear Cap
107	4	Wire Tie	121	1	Right Rear Cap
108	4	#8 x 5/8" Machine Screw	122	8	Foot Rail Plate
109	1	Chest Heart Rate Monitor	123	8	Right Rear Cap
110	2	1/4" x 1 1/2" Bolt	124	2	Cushion Wheel Stop
111	3	1/4" Nut	125	1	Tray Fan
112	1	Adjustment Handle	126	1	Tray Fan Cover
113	1	Handle Cap	*	-	User's Manual
114	4	Cushion Bushing			

Note: Specifications are subject to change without notice. For information about ordering replacement parts, see the back cover of this manual. *These parts are not illustrated.

EXPLODED DRAWING A

Model No. NTL17215.0 R1015A

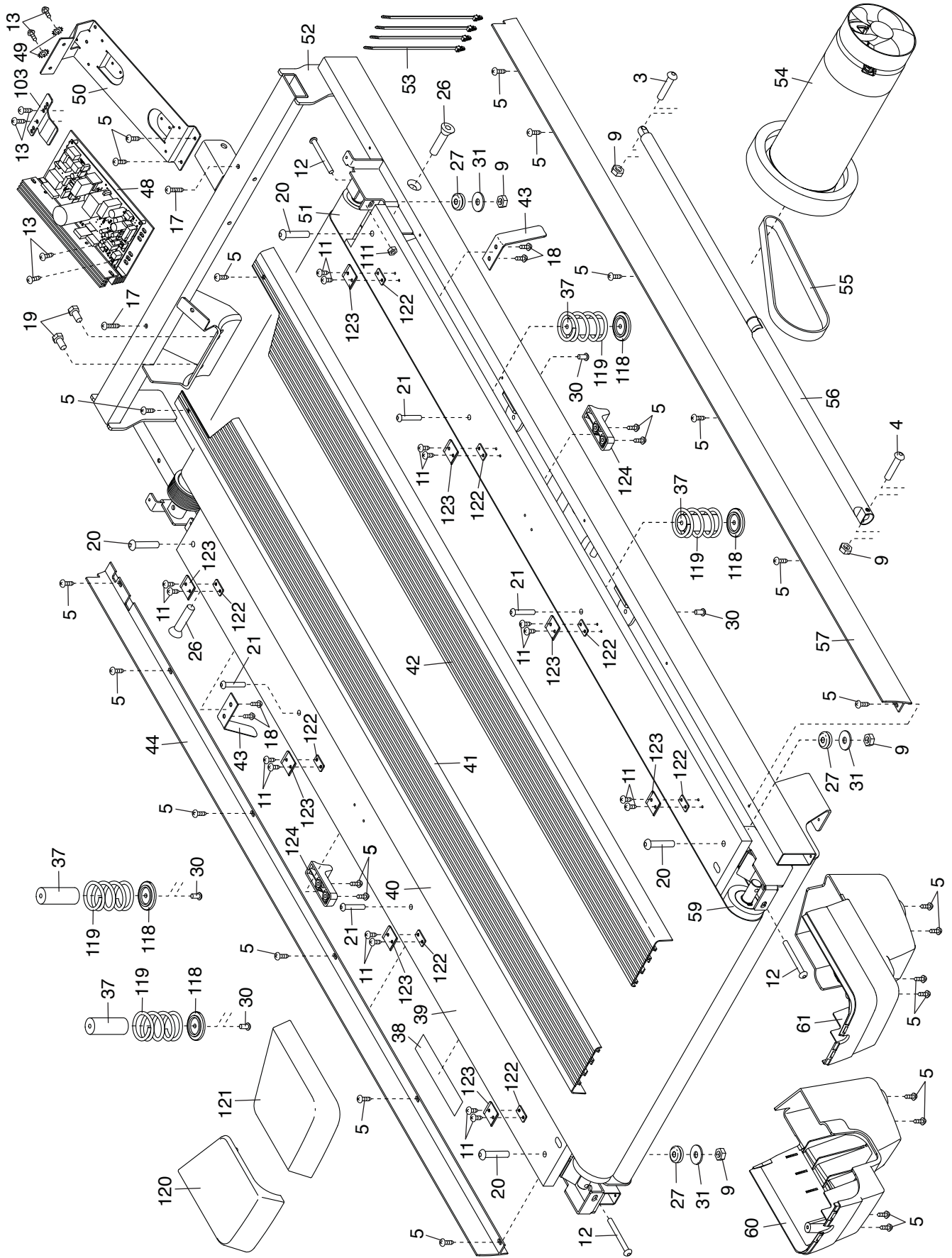

EXPLODED DRAWING B

Model No. NTL17215.0 R1015A

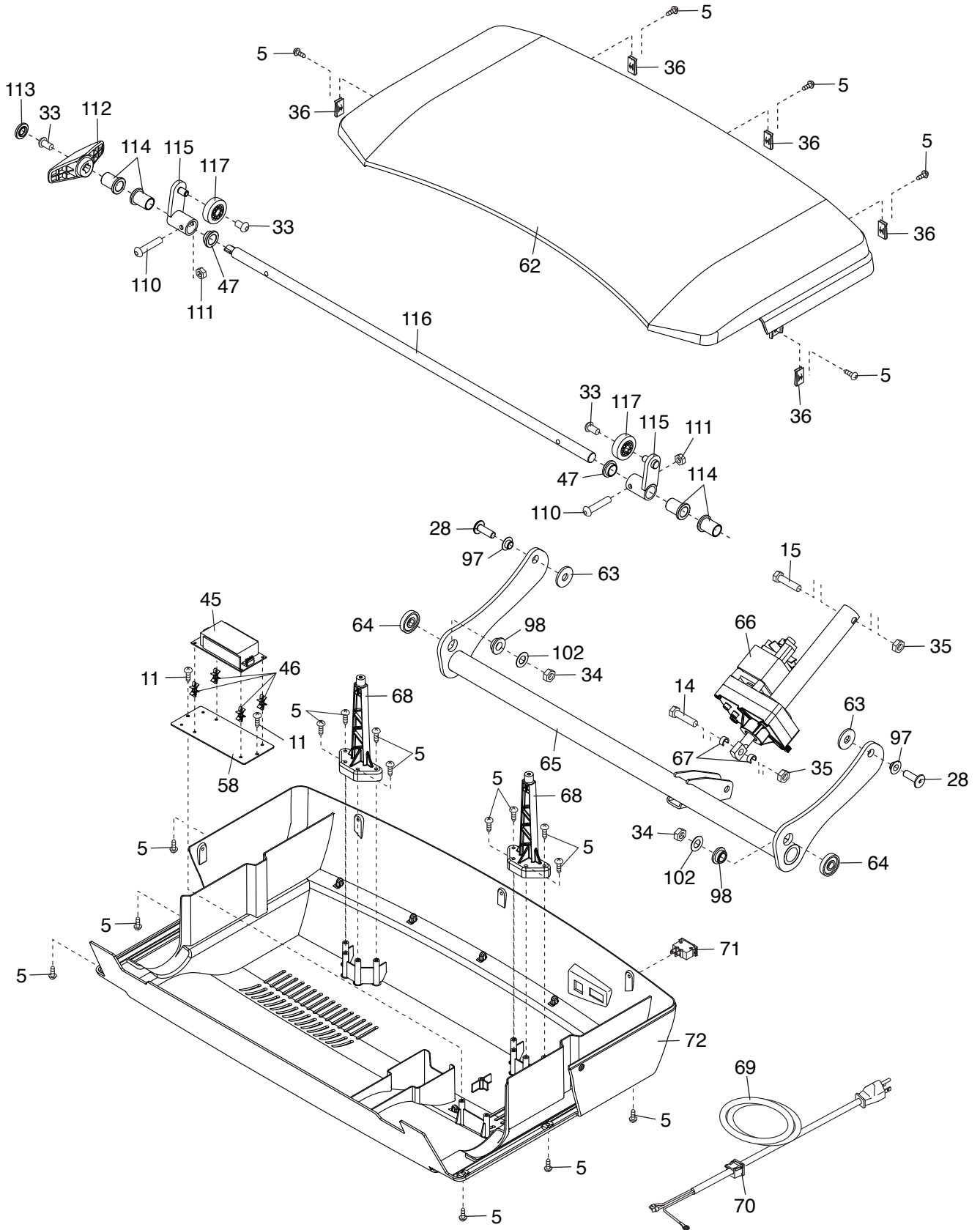

EXPLODED DRAWING C

Model No. NTL17215.0 R1015A

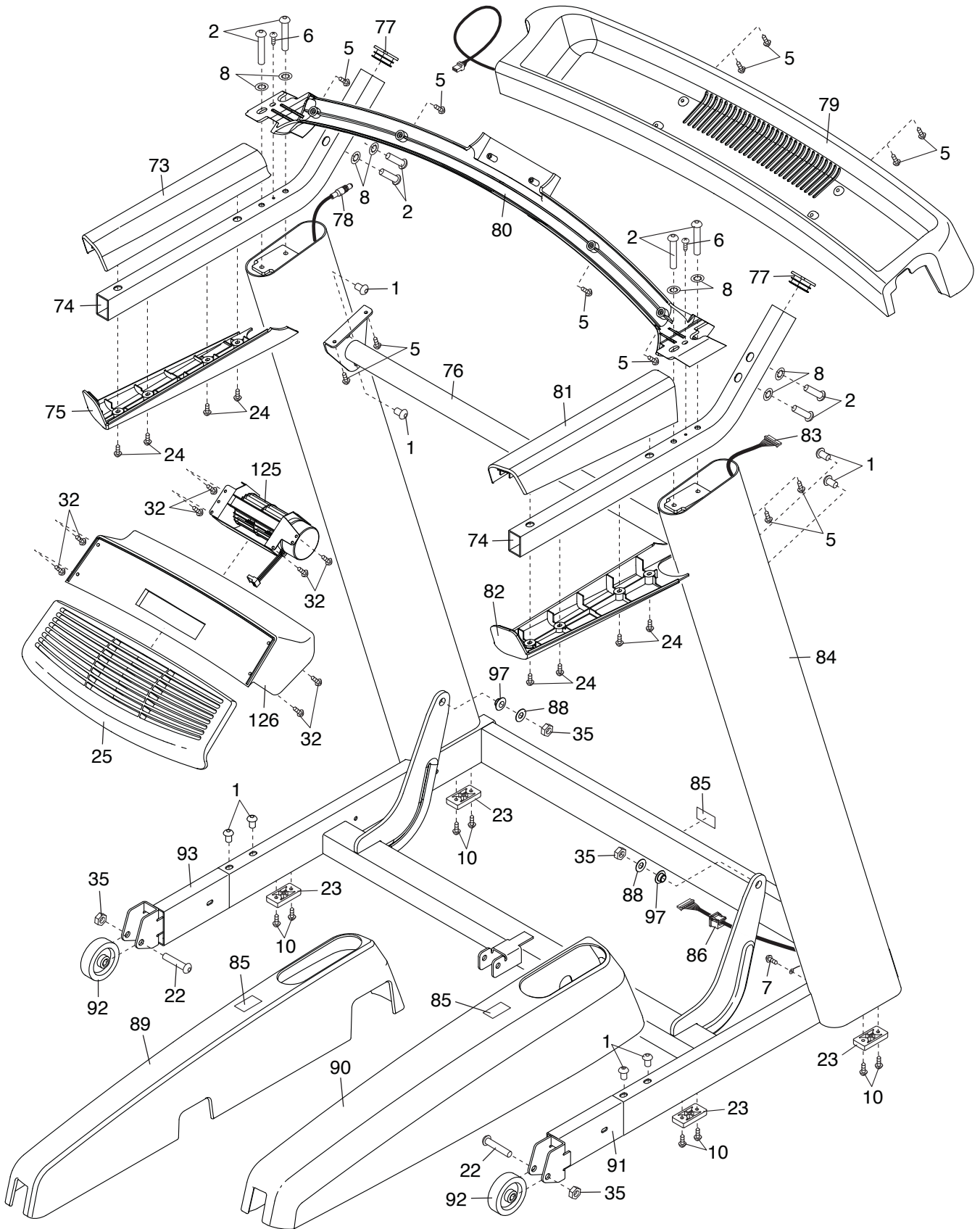

ORDERING REPLACEMENT PARTS

To order replacement parts, please see the front cover of this manual. To help us assist you, be prepared to provide the following information when contacting us:

- the model number and serial number of the product (see the front cover of this manual)
- the name of the product (see the front cover of this manual)
- the key number and description of the replacement part(s) (see the PART LIST and the EXPLODED DRAWING near the end of this manual)

LIMITED WARRANTY

IMPORTANT: To protect your fitness equipment with an extended service plan, see page 7.

ICON Health & Fitness, Inc. (ICON) warrants this product to be free from defects in workmanship and material, under normal use and service conditions. The frame and drive motor are warranted for the lifetime of the original purchaser (customer). Parts and electronics are warranted for five (5) years from the date of purchase. Labor is warranted for two (2) years from the date of purchase.

This warranty extends only to the customer. ICON's obligation under this warranty is limited to repairing or replacing, at ICON's option, the product through one of its authorized service centers. All repairs for which warranty claims are made must be preauthorized by ICON. If the product is shipped to a service center, freight charges to and from the service center will be the customer's responsibility. If replacement parts are shipped while the product is under warranty, the customer will be responsible for a minimal handling charge. For in-home service, the customer will be responsible for a minimal trip charge. This warranty does not extend to freight damage to the product. This warranty will automatically be voided if the product is used as a store display model, if the product is purchased or transported outside the USA, if all instructions in this manual are not followed, if the product is abused or improperly or abnormally used, or if the product is used for commercial or rental purposes. No other warranty beyond that specifically set forth above is authorized by ICON.

ICON is not responsible or liable for indirect, special, or consequential damages arising out of or in connection with the use or performance of the product; damages with respect to any economic loss, loss of property, loss of revenues or profits, loss of enjoyment or use, or costs of removal or installation; or other consequential damages of any kind. Some states do not allow the exclusion or limitation of incidental or consequential damages. Accordingly, the above limitation may not apply to the customer.

The warranty extended hereunder is in lieu of any and all other warranties, and any implied warranties of merchantability or fitness for a particular purpose are limited in their scope and duration to the terms set forth herein. Some states do not allow limitations on how long an implied warranty lasts. Accordingly, the above limitation may not apply to the customer.

This warranty provides specific legal rights; the customer may have other rights that vary from state to state.

ICON Health & Fitness, Inc., 1500 S. 1000 W., Logan, UT 84321-9813