

# WESLO<sup>®</sup>

## CADENCE R 5.2

[www.weslo.com](http://www.weslo.com)

Model No. WLTL29816C.1

Serial No. \_\_\_\_\_

Write the serial number in the space above for reference.

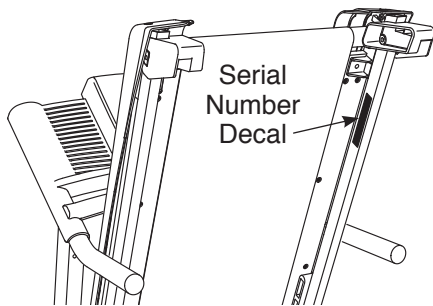

### ACTIVATE YOUR WARRANTY

To register your product and activate your warranty today, go to [www.iconservice.ca](http://www.iconservice.ca).

### CUSTOMER SERVICE

Call toll-free 1-888-936-4266  
Mon.–Fri. 7:30 a.m.–4:30 p.m. ET  
(excluding holidays)

or email us at  
[customerservice@iconcanada.ca](mailto:customerservice@iconcanada.ca)

Please do not contact the store.

### ⚠ CAUTION

Read all precautions and instructions in this manual before using this equipment. Save this manual for future reference.

## USER'S MANUAL

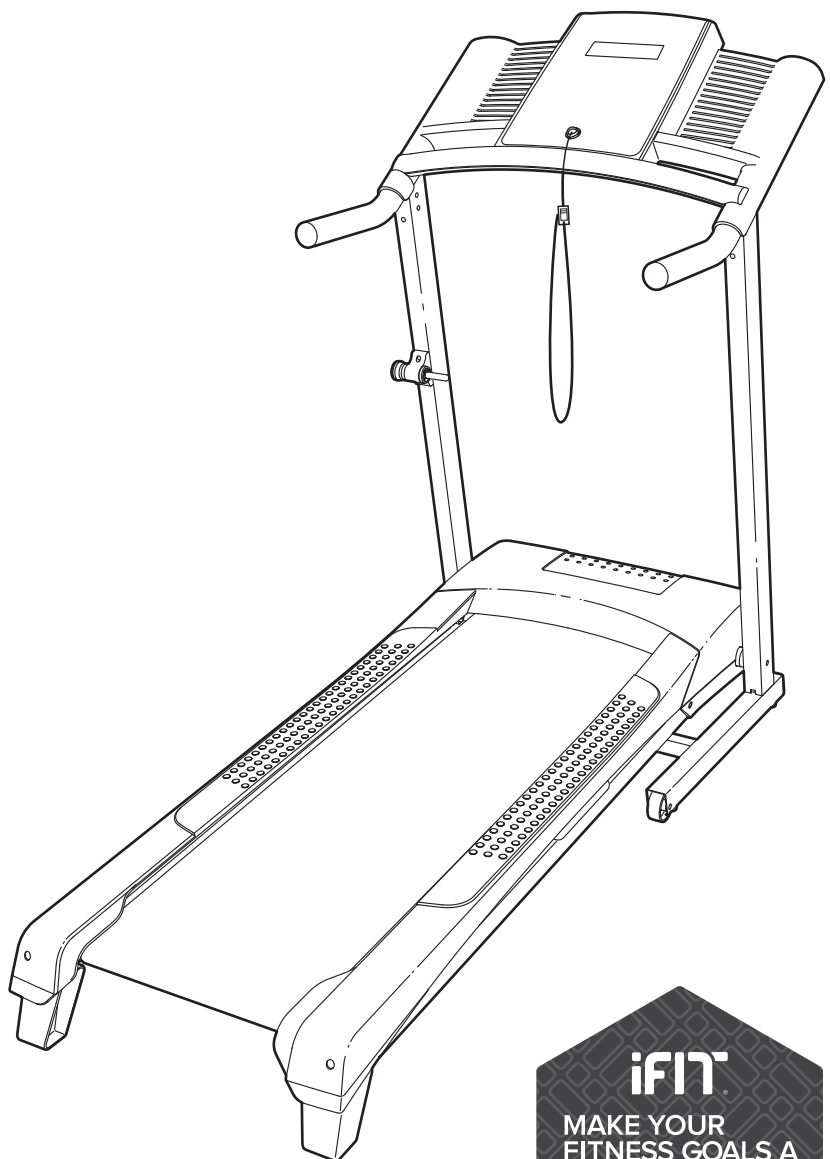

# TABLE OF CONTENTS

WARNING DECAL PLACEMENT ..... 2

IMPORTANT PRECAUTIONS ..... 3

BEFORE YOU BEGIN ..... 6

PART IDENTIFICATION CHART ..... 7

ASSEMBLY ..... 8

HOW TO USE THE TREADMILL ..... 12

FCC INFORMATION ..... 18

HOW TO FOLD AND MOVE THE TREADMILL ..... 19

MAINTENANCE AND TROUBLESHOOTING ..... 20

EXERCISE GUIDELINES ..... 22

PART LIST ..... 23

EXPLODED DRAWING ..... 24

ORDERING REPLACEMENT PARTS ..... Back Cover

LIMITED WARRANTY ..... Back Cover

## WARNING DECAL PLACEMENT

This drawing shows the location(s) of the warning decal(s). **If a decal is missing or illegible, see the front cover of this manual and request a free replacement decal. Apply the decal in the location shown.** Note: The decal(s) may not be shown at actual size.

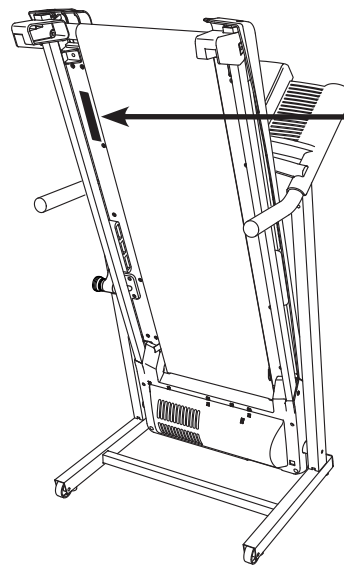

**▲WARNING:**  
Protect yourself and others from risk of serious injury. Read the user's manual, and:

- Stand only on the side rails when starting or stopping treadmill.
- Change speed in small increments.
- Hold handrails to prevent falling, and always wear the safety clip while operating the treadmill.
- Stop if you feel faint, dizzy, or short of breath.
- Fully engage the storage latch before the treadmill is moved or stored.
- Incline should be set to zero before folding the treadmill into a storage position.
- Never allow children on or around the treadmill.
- Remove the safety key when treadmill is not in use.
- Keep clothing, fingers, and hair away from moving parts.
- Never try to adjust or fix the belt while it is moving.
- Always wear athletic shoes while operating the treadmill.

WESLO and IFIT are registered trademarks of ICON Health & Fitness, Inc. App store is a trademark of Apple Inc., registered in the U.S. and other countries. Android and Google Play are trademarks of Google Inc. The BLUETOOTH® word mark and logos are registered trademarks of Bluetooth SIG, Inc. and are used under license. IOS is a trademark or registered trademark of Cisco in the U.S. and other countries and is used under license.

# IMPORTANT PRECAUTIONS

**⚠️ WARNING:** To reduce the risk of burns, fire, electric shock, or injury to persons, read all important precautions and instructions in this manual and all warnings on your treadmill before using your treadmill. ICON assumes no responsibility for personal injury or property damage sustained by or through the use of this product.

1. It is the responsibility of the owner to ensure that all users of this treadmill are adequately informed of all warnings and precautions.
2. Before beginning any exercise program, consult your physician. This is especially important for persons over age 35 or persons with pre-existing health problems.
3. The treadmill is not intended for use by persons with reduced physical, sensory, or mental capabilities or lack of experience and knowledge, unless they have been given supervision or instruction concerning use of the treadmill by someone responsible for their safety.
4. Use the treadmill only as described.
5. The treadmill is intended for home use only. Do not use the treadmill in any commercial, rental, or institutional setting.
6. Keep the treadmill indoors, away from moisture and dust. Do not put the treadmill in a garage or covered patio, or near water.
7. Place the treadmill on a level surface, with at least 8 ft. (2.4 m) of clearance behind it and 2 ft. (0.6 m) on each side. Do not place the treadmill on any surface that blocks air openings. To protect the floor or carpet from damage, place a mat under the treadmill.
8. Do not operate the treadmill where aerosol products are used or where oxygen is being administered.
9. Keep children under age 13 and pets away from the treadmill at all times.
10. The treadmill should be used only by persons weighing 250 lbs. (114 kg) or less.
11. Never allow more than one person on the treadmill at a time.
12. Wear appropriate exercise clothes while using the treadmill. Do not wear loose clothes that could become caught in the treadmill. Athletic support clothes are recommended for both men and women. *Always wear athletic shoes. Never use the treadmill with bare feet, wearing only stockings, or in sandals.*
13. Plug the power cord into a surge suppressor (not included), and plug the surge suppressor into an appropriate outlet (see page 12). To avoid overloading the circuit, do not plug other electrical devices, except for low-power devices such as cell phone chargers, into the surge suppressor or into an outlet on the same circuit.
14. Use only a surge suppressor that meets all of the specifications described on page 12. To purchase a surge suppressor, call the telephone number on the front cover of this manual.
15. Failure to use a properly functioning surge suppressor could result in damage to the control system of the treadmill. If the control system is damaged, the walking belt may slow, accelerate, or stop unexpectedly, which may result in a fall and serious injury.
16. Keep the power cord and the surge suppressor away from heated surfaces.
17. Never move the walking belt while the power is turned off. Do not operate the treadmill if the power cord or plug is damaged, or if the treadmill is not working properly. (See MAINTENANCE AND TROUBLESHOOTING on page 20 if the treadmill is not working properly.)
18. Read, understand, and test the emergency stop procedure before using the treadmill (see HOW TO TURN ON THE POWER on page 14). Always wear the clip while using the treadmill.

19. Always stand on the foot rails when starting or stopping the walking belt. Always hold the handrails while using the treadmill.
20. When a person is walking on the treadmill, the noise level of the treadmill will increase.
21. Keep fingers, hair, and clothing away from the moving walking belt.
22. The treadmill is capable of high speeds. Adjust the speed in small increments to avoid sudden jumps in speed.
23. The heart rate monitor is not a medical device. Various factors, including the user's movement, may affect the accuracy of heart rate readings. The heart rate monitor is intended only as an exercise aid in determining heart rate trends in general.
24. Never leave the treadmill unattended while it is running. Always remove the key, press the power switch into the off position (see the drawing on page 6 for the location of the power switch), and unplug the power cord when the treadmill is not in use.
25. Do not attempt to move the treadmill until it is properly assembled. (See ASSEMBLY on page 8 and HOW TO FOLD AND MOVE THE TREADMILL on page 19.) You must be able to safely lift 45 lbs. (20 kg) to move the treadmill.
26. When folding or moving the treadmill, make sure that the storage latch is holding the frame securely in the storage position.
27. Do not change the incline of the treadmill by placing objects under the treadmill.
28. Never insert any object into any opening on the treadmill.
29. Inspect and properly tighten all parts each time the treadmill is used.
30. **DANGER:** Always unplug the power cord immediately after use, before cleaning the treadmill, and before performing the maintenance and adjustment procedures described in this manual. Never remove the motor hood unless instructed to do so by an authorized service representative. Servicing other than the procedures in this manual should be performed by an authorized service representative only.
31. Over exercising may result in serious injury or death. If you feel faint, if you become short of breath, or if you experience pain while exercising, stop immediately and cool down.

**SAVE THESE INSTRUCTIONS**

# PROTECT

YOUR FITNESS EQUIPMENT  
WITH AN EXTENDED SERVICE PLAN



Your new fitness equipment represents a significant investment in your health. Protect your investment now from unexpected mechanical or electrical failures for up to five years.

---

## PLAN FEATURES

- Protection for one to five years
- Over 100 authorized repair centers
- Highly trained repair technicians
- A national toll-free repair hotline
- Simple repair claim procedure
- No claim forms
- Easy enrollment
- Fast, efficient repair anywhere in Canada
- In-home repairs covered
- Parts and labour covered
- Mechanical and electrical failures covered

To protect your fitness equipment today, please  
call Customer Care at **1-888-936-4266**  
Or, email us at [customerservice@iconcanada.ca](mailto:customerservice@iconcanada.ca)

 **ICON**<sup>™</sup>  
du/of Canada Inc.

# BEFORE YOU BEGIN

Thank you for selecting the new WESLO® CADENCE R 5.2 treadmill. The CADENCE R 5.2 treadmill offers a selection of features designed to make your workouts at home more effective. And when you're not exercising, the unique treadmill can be folded up, requiring less than half the floor space of other treadmills.

**For your benefit, read this manual carefully before using the treadmill.** If you have questions after

reading this manual, please see the front cover of this manual. To help us assist you, note the product model number and serial number before contacting us. The model number and the location of the serial number decal are shown on the front cover of this manual.

Before reading further, please review the drawing below and familiarize yourself with the labeled parts.

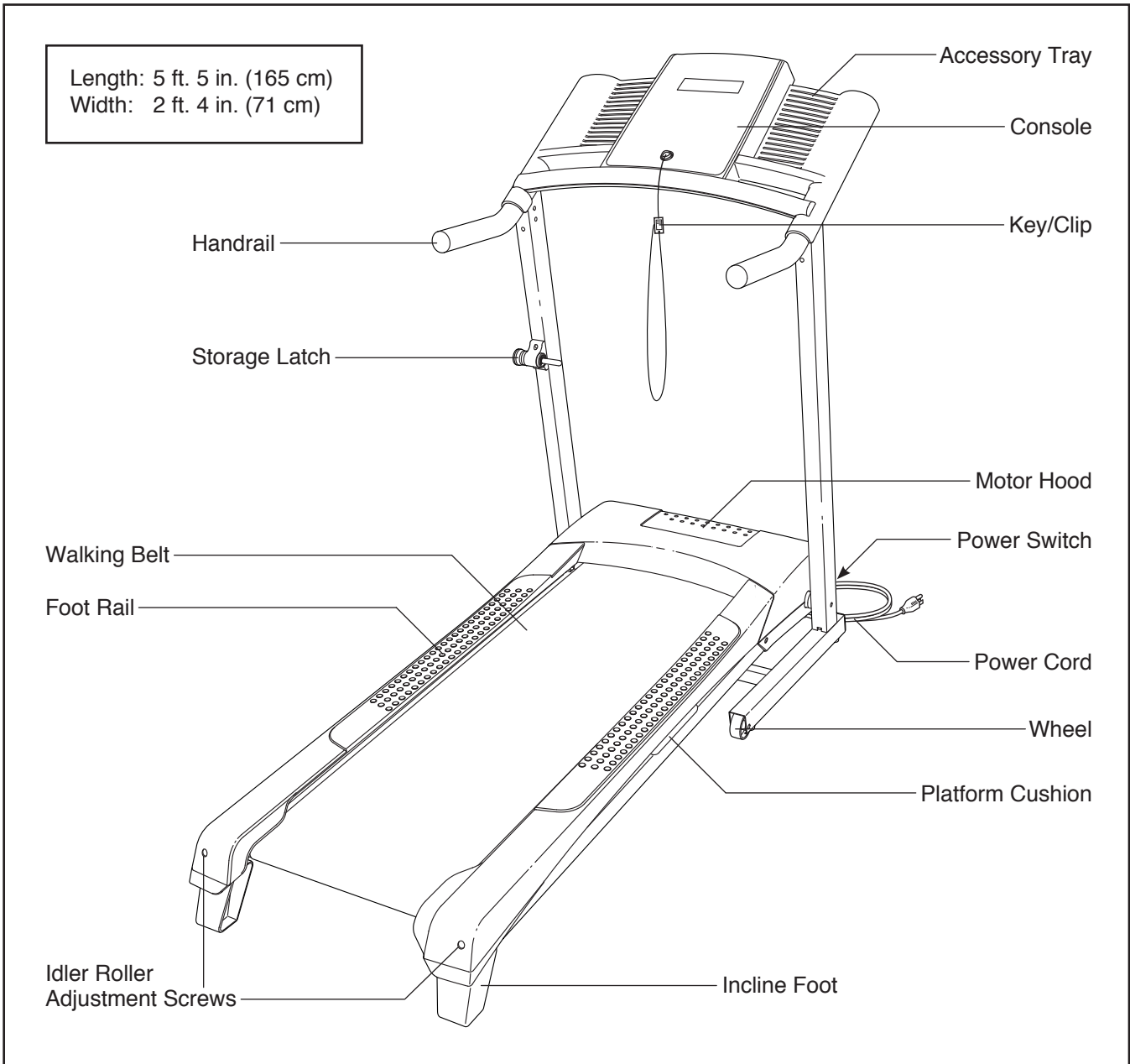

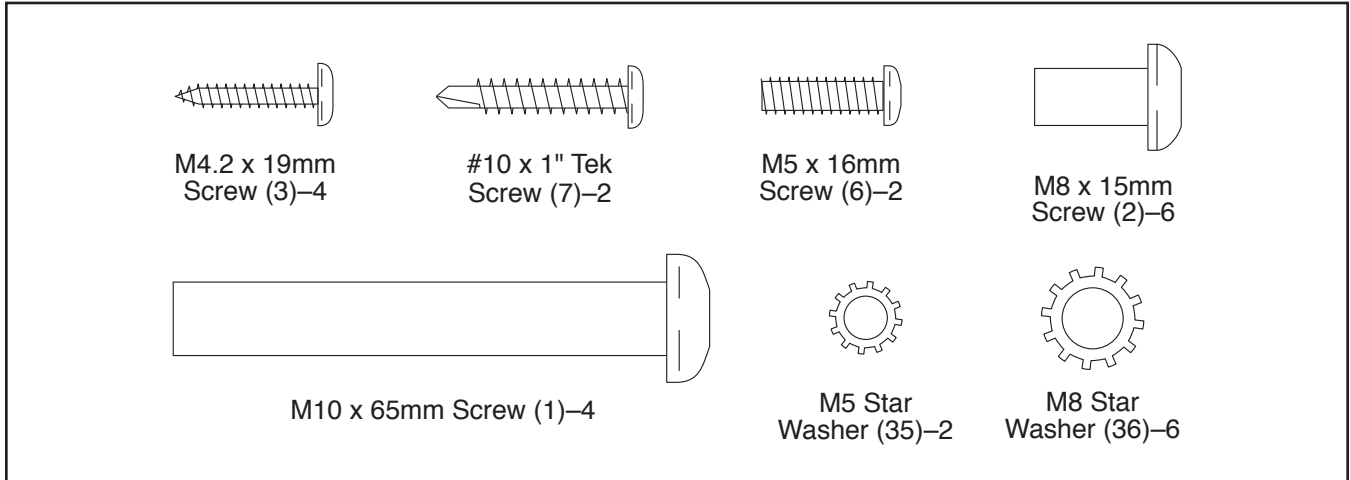

# PART IDENTIFICATION CHART

Use the drawings below to identify small parts used for assembly. The number in parentheses below each drawing is the key number of the part, from the PART LIST near the end of this manual. The number following the key number is the quantity used for assembly. **Note: If a part is not in the hardware kit, check to see whether it is preattached. Extra parts may be included.**



# ASSEMBLY

- Assembly requires two persons.
  - Place all parts in a cleared area and remove the packing materials. Do not dispose of the packing materials until you finish all assembly steps.
  - After shipping, there may be an oily substance on the exterior of the treadmill. This is normal. If there is an oily substance on the treadmill, wipe it off with a soft cloth and a mild, non-abrasive cleaner.
  - Left parts are marked “L” or “Left” and right parts are marked “R” or “Right.”
  - To identify small parts, see page 7.
  - Assembly requires the following tools:
    - the included hex keys 
    - one Phillips screwdriver 
- To avoid damaging parts, do not use power tools.

## 1. Go to [www.iconservice.ca/CustomerService/registration](http://www.iconservice.ca/CustomerService/registration) and register your product.

- activates your warranty
- saves you time if you ever need to contact Customer Service
- allows us to notify you of upgrades and offers

Note: If you do not have Internet access, call Customer Service (see the front cover of this manual) and register your product.

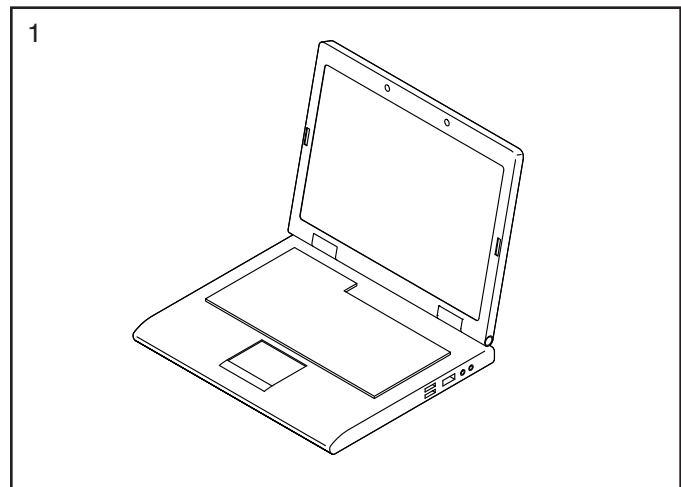

## 2. Make sure that the power cord is unplugged.

With the help of a second person, carefully tip the treadmill onto its left side. Unfold the Frame (50) away from the Left and Right Uprights (73, 74). **Do not lean on the Uprights.**

Next, orient the Base (72) as shown. Attach the Base to the Uprights (73, 74) with four M10 x 65mm Screws (1); **start all four Screws, and then tighten them.**

Then, raise the Uprights (73, 74) so that the Base (72) is flat on the floor.

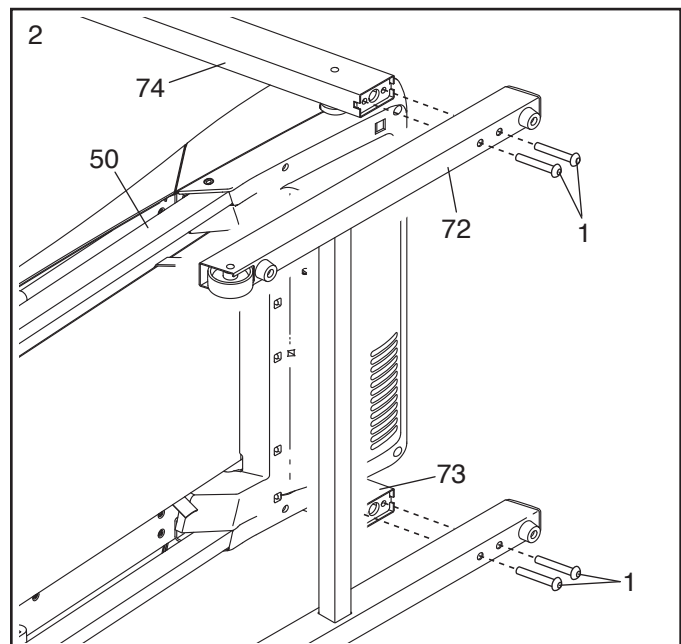

3. Set the console assembly (A) face down on a soft surface to avoid scratching the console assembly.

Identify the Right Handrail (69), which has a large hole (B) in the location shown. Hold the Right Handrail near the console assembly (A).

Next, insert the console wire (C) into the large hole (B) in the side of the Right Handrail (69). Using needle-nose pliers, carefully grip the connector (D) and pull the console wire out of the hole near the bracket (E) on the Right Handrail.

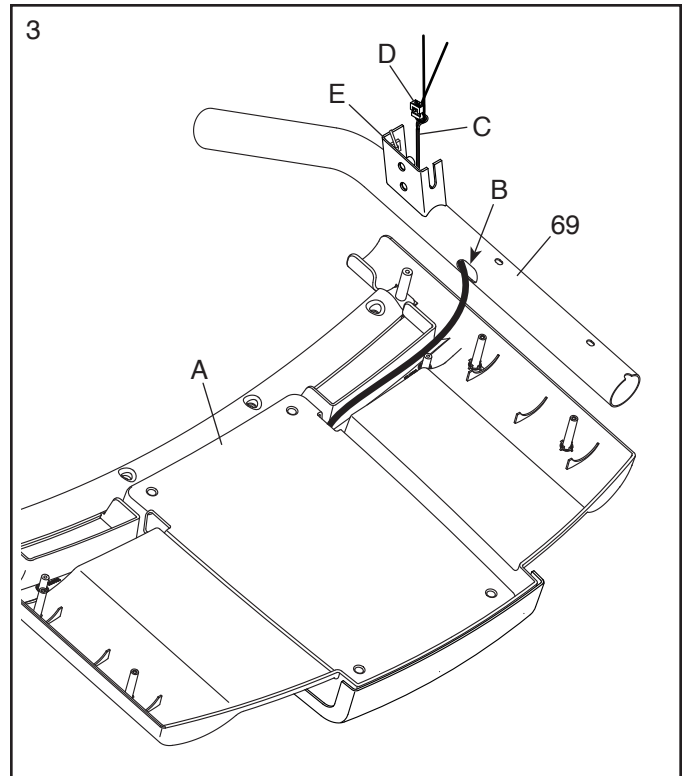

4. Set the Right Handrail (69) on the console assembly (A). **Make sure that the console wire (C) is not pinched.**

**See the inset drawing.** Remove the tie (F) from the bracket (E) on the Right Handrail (69). If necessary, press the Cage Nuts (85) back into place.

Next, start an M5 x 16mm Screw (6) with an M5 Star Washer (35) into the Right Handrail (69), and then start two M4.2 x 19mm Screws (3) into the Right Handrail. Tighten the M5 x 16mm Screw and then tighten the two M4.2 x 19mm Screws; **do not overtighten the Screws.**

**Attach the Left Handrail (not shown) to the console assembly (A) in the same way.** Note: There is no wire on the left side.

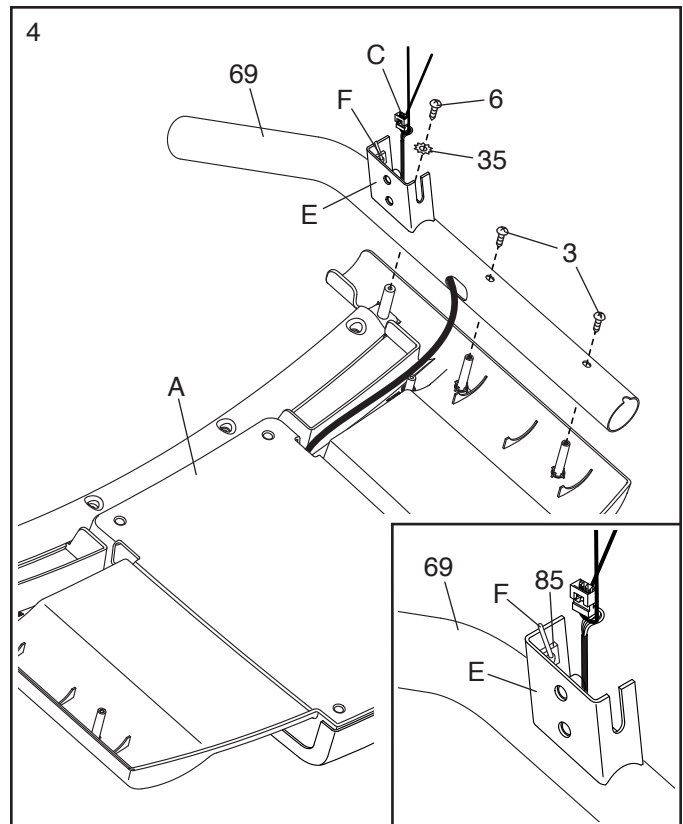

5. With the help of a second person, hold the console assembly (A) near the Right Upright (74). Remove the tie (F) from the Upright Wire (71).

**See the inset drawing.** Connect the Upright Wire (71) to the console wire (G). **The connectors should slide together easily and snap into place.** If they do not, turn one connector and try again. **IF YOU DO NOT CONNECT THE CONNECTORS PROPERLY, THE CONSOLE MAY BECOME DAMAGED WHEN YOU TURN ON THE POWER.** Then, insert the connectors and the excess wire into the Right Upright (74).

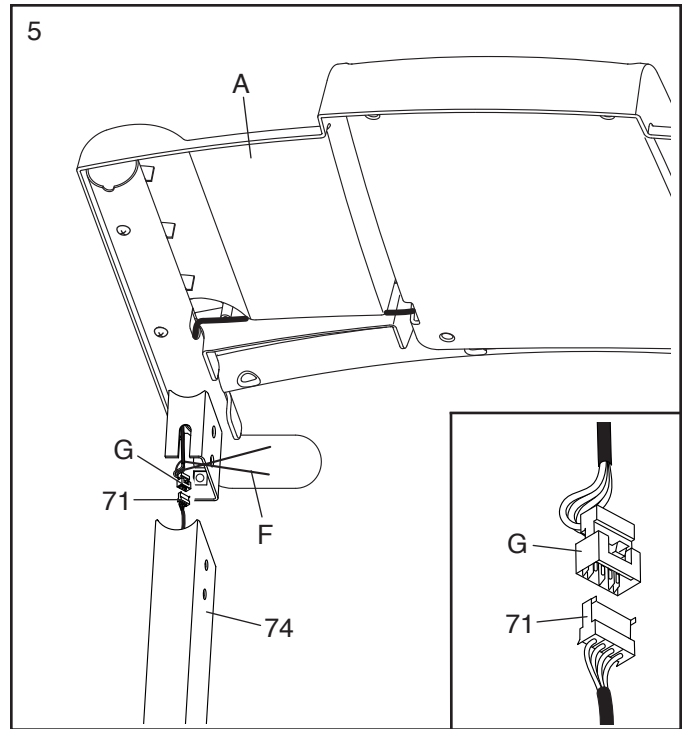

6. Set the console assembly (A) on the Left and Right Uprights (73, 74). **Make sure that no wires are pinched.** Start four M8 x 15mm Screws (2) with four M8 Star Washers (36) into the Uprights as shown; **do not tighten the Screws yet.**

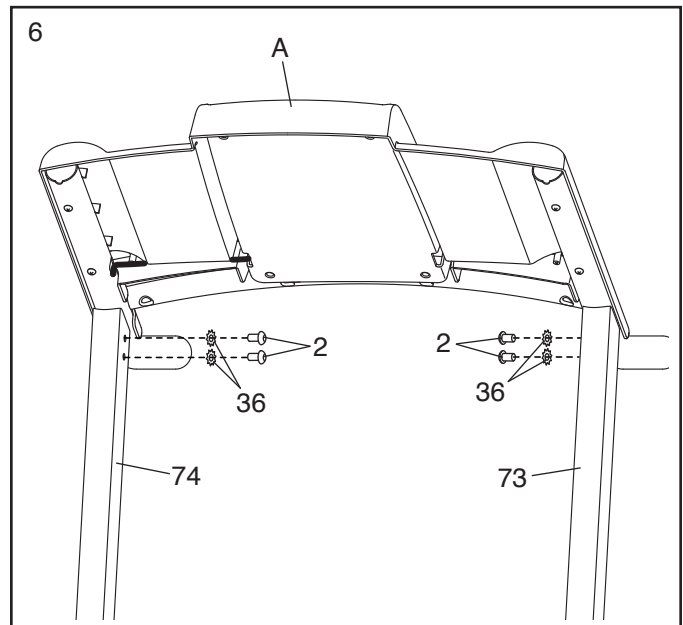

7. Start an M8 x 15mm Screw (2) with an M8 Star Washer (36) into each Upright (73, 74).

**Firmly tighten all six M8 x 15mm Screws (2).**

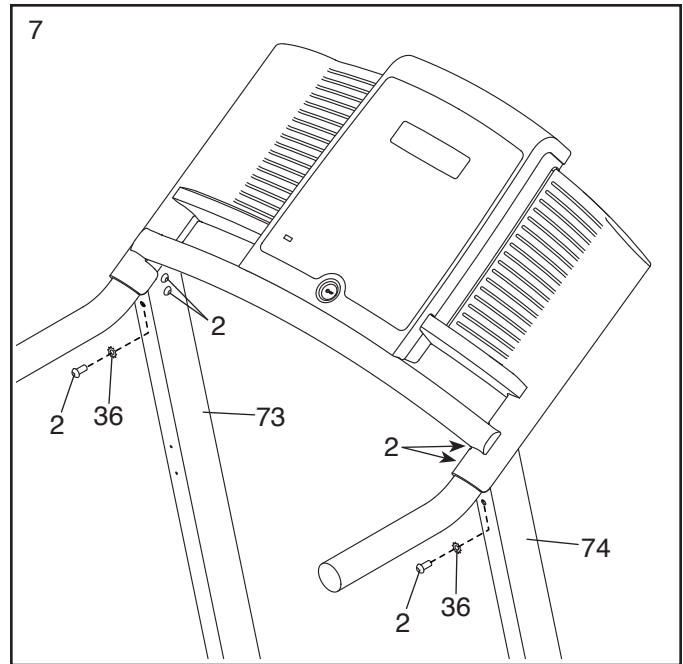

8. Attach the Storage Latch (42) to the Left Upright (73) with two #10 x 1" Tek Screws (7); **start both Tek Screws, and then tighten them.**

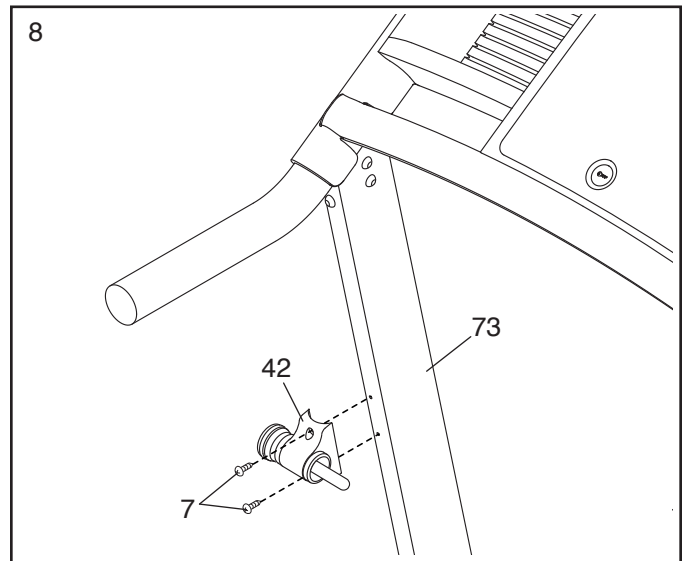

9. **Make sure that all parts are properly tightened before you use the treadmill.** To protect the floor or carpet, place a mat under the treadmill. To avoid damage to the console, keep the treadmill out of direct sunlight. Keep the included hex keys in a secure place. One of the hex keys is used to adjust the walking belt (see page 21). Note: Extra parts may be included.

# HOW TO USE THE TREADMILL

## HOW TO CONNECT THE POWER CORD

### Use a Surge Suppressor

Your treadmill, like other electronic equipment, can be damaged by sudden voltage changes in your home's power. Voltage surges, spikes, and noise interference can result from weather conditions or from other appliances being turned on or off. **To decrease the risk of damaging the treadmill, always use a surge suppressor with the treadmill. To purchase a surge suppressor, see precaution 14 on page 3.**

Use only a surge suppressor that is UL 1449 listed as a transient voltage surge suppressor (TVSS). The surge suppressor must have a UL suppressed voltage rating of 400 volts or less and a minimum surge dissipation of 450 joules. The surge suppressor must also be electrically rated for 120 volts AC and 15 amps. There must be a monitoring light on the surge suppressor to indicate whether it is functioning properly. **Failure to use a properly functioning surge suppressor could result in damage to the control system of the treadmill and serious injury to users.**

### Plug in the Power Cord

**The treadmill must be grounded.** If it should malfunction or break down, grounding provides a path of least resistance for electric current to reduce the risk of electric shock. The treadmill power cord has a plug with a grounding pin (see drawing 1 on this page).

**⚠ DANGER:** Improper connection of the power cord increases the risk of electric shock. Do not modify the plug—if it will not fit an outlet, have a proper outlet installed by a qualified electrician. If you are unsure whether the treadmill is properly grounded, contact a qualified electrician.

Plug the power cord into a surge suppressor, and plug the surge suppressor into an appropriate outlet that is properly installed and grounded in accordance with all local codes and ordinances. **The outlet must be on a nominal 120-volt circuit capable of carrying 15 or**

**more amps. To avoid overloading the circuit, do not plug other electrical devices, except for low-power devices such as cell phone chargers, into the surge suppressor or into an outlet on the same circuit. IMPORTANT: If the treadmill is connected to an AFCI-equipped outlet and your circuit breaker trips repeatedly when the treadmill is used, see the front cover of this manual to purchase an arc filter.**

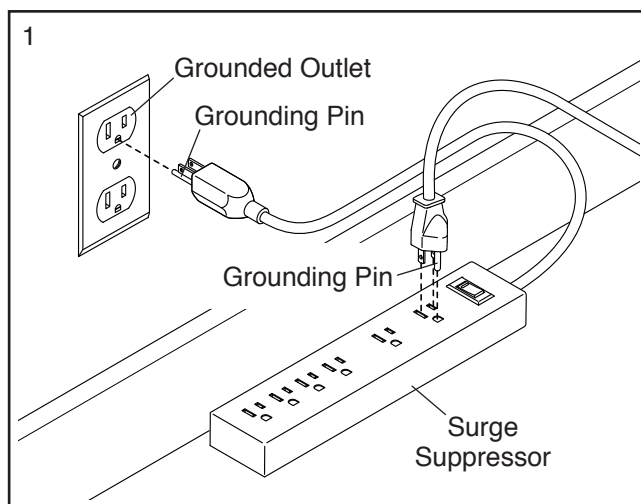

A temporary adapter may be used to connect the surge suppressor to a 2-pole receptacle if a properly grounded outlet is not available.

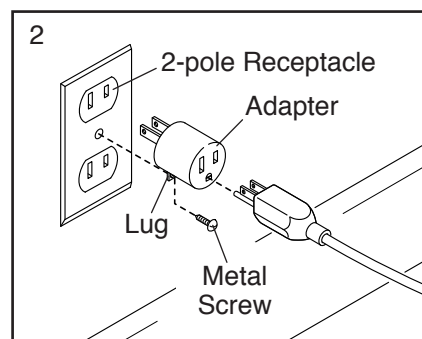

The lug or wire extending from the adapter must be connected with a metal screw to a permanent ground such as a properly grounded outlet box cover. **Some 2-pole receptacle outlet box covers are not grounded. Before using an adapter, contact a qualified electrician to determine whether the outlet box cover is grounded. The temporary adapter should be used only until a properly grounded outlet can be installed by a qualified electrician.**

## CONSOLE DIAGRAM

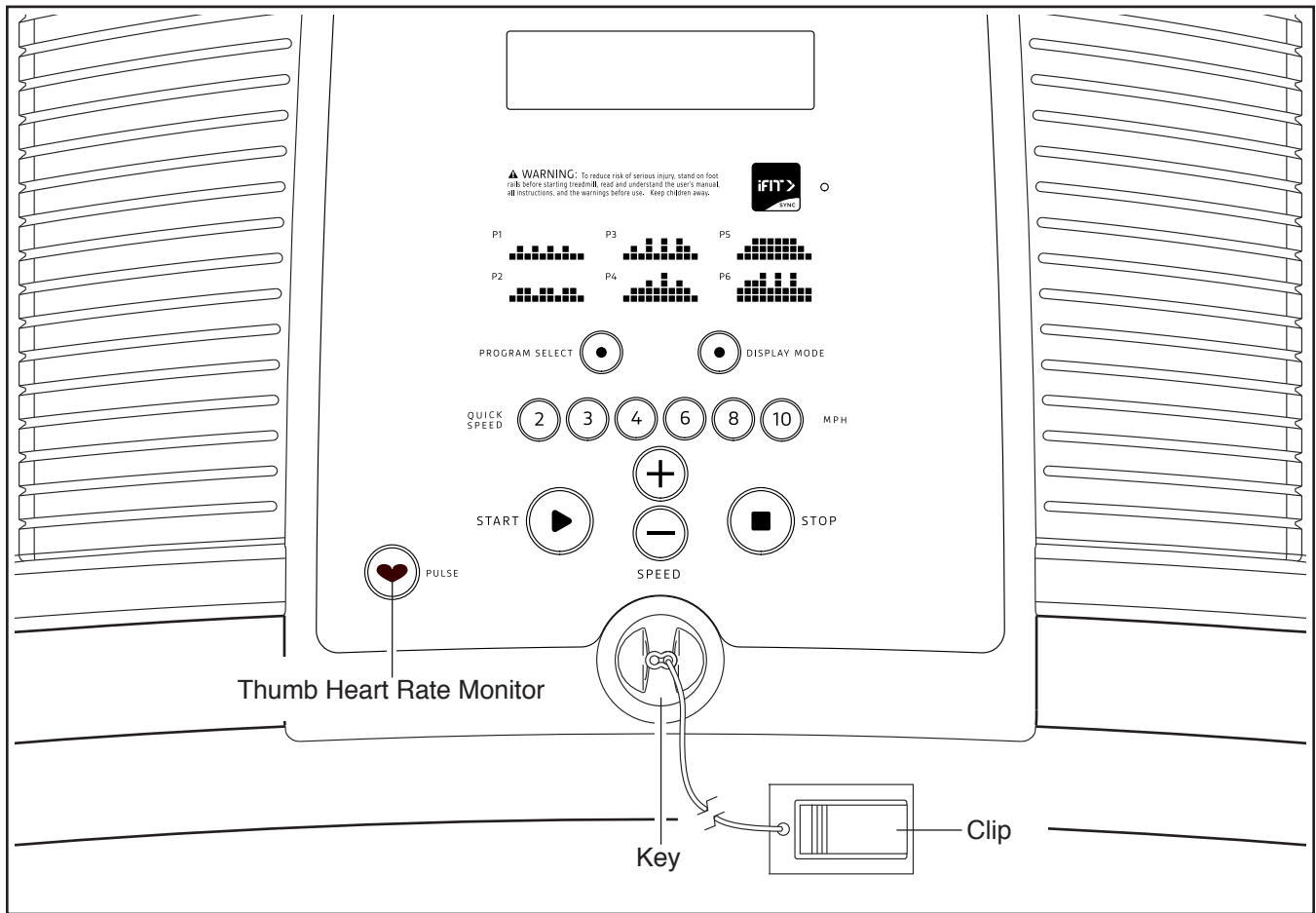

### FEATURES OF THE CONSOLE

The treadmill console offers a selection of features designed to make your workouts more effective and enjoyable. When the manual mode of the console is selected, the speed of the treadmill can be changed with the touch of a button. As you exercise, the displays will provide continuous exercise feedback. You can even measure your heart rate using the thumb heart rate monitor or a compatible heart rate monitor. **See page 17 for information about purchasing an optional chest heart rate monitor.**

The console also offers preset workouts. Each workout automatically controls the speed of the treadmill as it guides you through an effective exercise session.

**To turn on the power, see page 14. To use the manual mode, see page 14. To use a preset workout, see page 16. To connect your tablet to the console, see page 17. To connect your heart rate monitor to the console, see page 17. To change the incline of the treadmill, see page 18.**

**IMPORTANT: If there is a sheet of plastic on the console, remove the plastic. To prevent damage to the walking platform, wear clean athletic shoes while using the treadmill. The first time the treadmill is used, observe the alignment of the walking belt, and center the walking belt if necessary (see page 21).**

## HOW TO TURN ON THE POWER

**IMPORTANT:** If the treadmill has been exposed to cold temperatures, allow it to warm to room temperature before you turn on the power. If you do not do this, you may damage the console displays or other electrical components.

Plug in the power cord (see page 12). Next, locate the power switch on the treadmill frame near the power cord. Make sure that the switch is in the reset position.

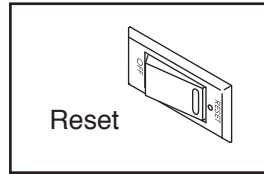

Next, stand on the foot rails of the treadmill. Locate the clip attached to the key (see the drawing on page 13), and slide the clip securely onto the waistband of your clothes. Then, insert the key into the console. After a moment, the displays will light. **IMPORTANT:** In an emergency, the key can be pulled from the console, causing the walking belt to slow to a stop. Test the clip by carefully taking a few steps backward; if the key is not pulled from the console, adjust the position of the clip.

## HOW TO USE THE MANUAL MODE

### 1. Insert the key into the console.

See HOW TO TURN ON THE POWER above.

### 2. Select the manual mode.

When the key is inserted, the manual mode will be selected. If you have selected a preset workout, reselect the manual mode by pressing the Program Select button repeatedly until only zeros appear in the displays.



### 3. Start the walking belt.

To start the walking belt, press the Start button. The walking belt will begin to move at 1 mph. As you exercise, change the speed of the walking belt as desired by pressing the Speed increase and decrease buttons. Each time you press one of the buttons, the speed setting will change by 0.1 mph; if you hold down the button, the speed setting will change by 0.5 mph. Note: After you press the buttons, it may take a moment for the walking belt to reach the selected speed setting.

To stop the walking belt, press the Stop button. The time will begin to flash in the display. To restart the walking belt, press the Start button.

### 4. Follow your progress with the displays.

**The track**—The track represents a distance of 1/4 mile (400 m). As you walk or run on the treadmill, the indicators around the track will appear in succession until the entire track appears. The track will then disappear and the indicators will again begin to appear in succession.

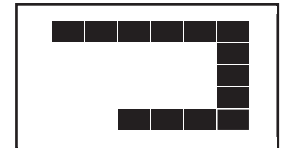

### The lower left display

—As you exercise, the lower left display can show the elapsed time and the distance that you have walked or run. Note: When a preset workout is selected, the lower left corner of the display will show the time remaining in the workout instead of the elapsed time.



**The lower right display**—The lower right display can show the speed of the walking belt and the approximate number of calories that you have burned.



**The priority display**—The upper display is the priority display. The priority display can show the elapsed time, the distance that you have walked or run, the speed of the walking belt, or the approximate number of calories you have burned. Press the Display Mode button repeatedly until the priority display shows the information that you are most interested in viewing. Note: While information is shown in the priority display, the same information will not be shown in the lower left or right display.



To reset the displays, press the Stop button, remove the key, and then reinsert the key.

Note: The console can display speed and distance in either miles or kilometers. To see which unit of measurement is selected, hold down the Stop button, insert the key into the console, and then release the Stop button. An M for metric kilometers or an E for English miles will appear in the priority display. Press the Speed increase button to change the unit of measurement. When the desired unit of measurement is selected, remove the key and then reinsert it.

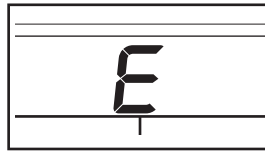

## 5. Measure your heart rate if desired.

You can measure your heart rate using either the thumb heart rate monitor or a compatible heart rate monitor. **For information about purchasing an optional chest heart rate monitor, see page 17.**

The console is compatible with all BLUETOOTH® Smart heart rate monitors. To connect your heart rate monitor to the console, see page 17.

**Note: If you use both heart rate monitors at the same time, the BLUETOOTH Smart heart rate monitor will have priority.**

To measure your heart rate, **stand on the foot rails** and place your thumb on the pulse sensor (see the drawing on page 13). **Do not press too hard, or the circulation in your thumb will be restricted and your pulse may not be detected.** When your pulse is detected, a heart-shaped indicator in the lower right display will flash each time your heart beats, one or two dashes will appear, and then your heart rate will be shown. **For the most accurate heart rate reading, hold your thumb on the pulse sensor for at least 15 seconds.**

If the displayed heart rate appears to be too high or too low, or if your heart rate is not displayed, lift your thumb for a few seconds, and then reposition your thumb on the pulse sensor. Remember to stand still while measuring your heart rate.

## 6. When you are finished exercising, remove the key from the console.

Step onto the foot rails, press the Stop button, remove the key from the console, and put it in a secure place. When you are finished using the treadmill, press the power switch into the off position and unplug the power cord. **IMPORTANT: If you do not do this, the treadmill's electrical components may wear prematurely.**

## HOW TO USE A PRESET WORKOUT

### 1. Insert the key into the console.

See HOW TO TURN ON THE POWER on page 14.

### 2. Select one of the four preset workouts.

To select a preset workout, press the Program Select button repeatedly; "P- 1," "P- 2," "P- 3," "P- 4," "P- 5" or "P- 6" will appear in the priority display for a few seconds to show which workout is selected. The maximum speed of the workout and the duration of the workout will also appear in the display for a few seconds.

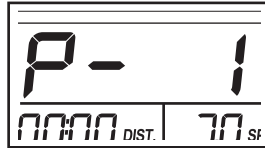

Each workout consists of 30 one-minute segments. One speed setting is programmed for each segment. Note: The same speed setting may be programmed for consecutive segments. The profiles on the console show how the speed of the walking belt will change during the workouts.

### 3. Start the walking belt.

Press the Start button to start the workout. When you press the button, the treadmill will automatically adjust to the speed setting that is programmed for the first segment. Hold the handrails and begin walking.

At the end of each segment, a series of tones will sound. If a different speed setting is programmed for the next segment, the speed setting will flash in the display to alert you and the treadmill will automatically adjust to the new speed setting. The workout will continue in this way until the last segment ends. The walking belt will then slow to a stop.

If the speed setting is too high or too low during the workout, you can manually override the setting by pressing the Speed buttons; **however, when the current segment of the workout ends, the treadmill will automatically adjust to the speed setting for the next segment.**

To stop the workout temporarily, press the Stop button. The time will begin to flash in the display. To restart the workout, press the Start button. The walking belt will begin to move at 1 mph. When the next segment begins, the treadmill will automatically adjust to the speed setting programmed for the next segment.

### 4. Follow your progress with the displays.

See step 4 on pages 14 and 15.

### 5. Measure your heart rate if desired.

See step 5 on page 15.

### 6. When you are finished exercising, remove the key from the console.

See step 6 on page 15.

## HOW TO CONNECT YOUR TABLET TO THE CONSOLE

The console supports BLUETOOTH connections to tablets via the iFit Bluetooth Tablet app and to compatible heart rate monitors. Note: Other BLUETOOTH connections are not supported.

### 1. Download and install the iFit Bluetooth Tablet app on your tablet.

On your iOS® or Android™ tablet, open the App Store<sup>SM</sup> or the Google Play™ store, search for the free iFit Bluetooth Tablet app, and then install the app on your tablet. **Make sure that the BLUETOOTH option is enabled on your tablet.**

Then, open the iFit Bluetooth Tablet app and follow the instructions to set up an iFit account and customize settings.

### 2. Connect your heart rate monitor to the console if desired.

If you are connecting both your heart rate monitor and your tablet to the console, **you must connect your heart rate monitor before you connect your tablet.** See HOW TO CONNECT YOUR HEART RATE MONITOR TO THE CONSOLE at the left.

### 3. Connect your tablet to the console.

Press the iFit Sync button on the console; the console pairing number will appear in the display. Then, follow the instructions in the iFit Bluetooth Tablet app to connect your tablet to the console.

When a connection is established, the LED on the console will turn solid blue.

### 4. Record and track your workout information.

Follow the instructions in the iFit Bluetooth Tablet app to record and track your workout information.

### 5. Disconnect your tablet from the console if desired.

To disconnect your tablet from the console, first select the disconnect option in the iFit Bluetooth Tablet app. Then, press and hold the iFit Sync button on the console until the LED on the console turns solid green.

Note: All BLUETOOTH connections between the console and other devices (including any tablets, heart rate monitors, and so forth) will be disconnected.

## THE OPTIONAL CHEST HEART RATE MONITOR

Whether your goal is to burn fat or to strengthen your cardiovascular system, the key to achieving the best results is to maintain the proper heart rate during your workouts.

The optional chest heart rate monitor will enable you to continuously monitor your heart rate while you exercise, helping you to reach your personal fitness goals. **To purchase a chest heart rate monitor, please see the front cover of this manual.**

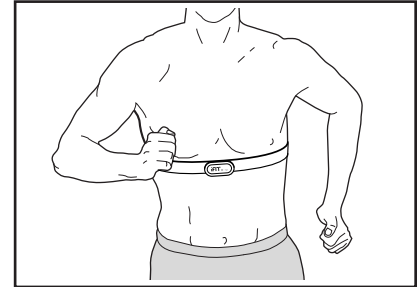

Note: The console is compatible with all BLUETOOTH Smart heart rate monitors.

## HOW TO CONNECT YOUR HEART RATE MONITOR TO THE CONSOLE

The console is compatible with all BLUETOOTH Smart heart rate monitors.

To connect your BLUETOOTH Smart heart rate monitor to the console, press the iFit Sync button on the console; the console pairing number will appear in the display. When a connection is established, the LED on the console will flash red twice.

Note: If there is more than one compatible heart rate monitor near the console, the console will connect to the heart rate monitor with the strongest signal.

To disconnect your heart rate monitor from the console, press and hold the iFit Sync button on the console until the LED on the console turns solid green.

Note: All BLUETOOTH connections between the console and other devices (including any tablets, heart rate monitors, and so forth) will be disconnected.

## HOW TO CHANGE THE INCLINE OF THE TREADMILL

To vary the intensity of your exercise, you can change the incline of the treadmill. There are two incline levels. **Before changing the incline, remove the key and unplug the power cord.** Next, fold the treadmill to the storage position (see page 19).

To change the incline, rotate both incline feet to the desired position. **CAUTION: Before using the treadmill, make sure that both incline feet are in the same position and are held firmly in place.**

After you have adjusted the incline feet, lower the treadmill (see page 19).

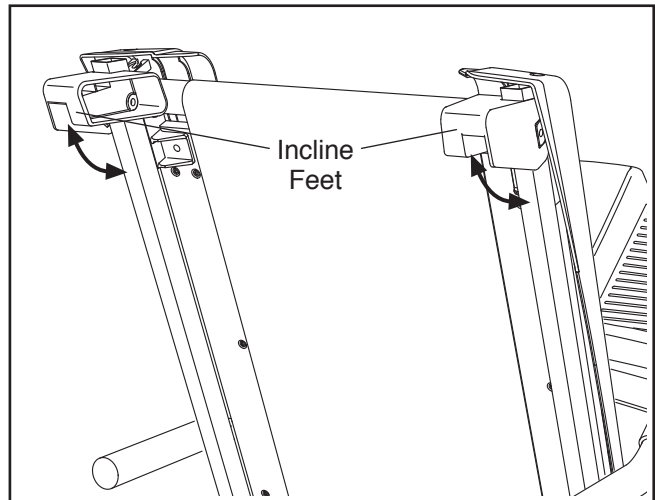

---

## FCC INFORMATION

This console has been tested and found to comply with the limits for a Class B digital device, pursuant to part 15 of the FCC Rules. These limits are designed to provide reasonable protection against harmful interference in a residential installation. This equipment generates, uses, and can radiate radio frequency energy and, if not installed and used in accordance with the instructions, may cause harmful interference to radio communications. However, there is no guarantee that interference will not occur in a particular installation. If this equipment does cause harmful interference to radio or television reception, which can be determined by turning the equipment off and on, try to correct the interference by one or more of the following measures:

- Reorient or relocate the receiving antenna.
- Increase the separation between the equipment and the receiver.
- Connect the equipment into an outlet on a circuit different from that to which the receiver is connected.
- Consult the dealer or an experienced radio/TV technician for help.

**FCC CAUTION: To assure continued compliance, use only shielded interface cables when connecting to computer or peripheral devices. Changes or modifications not expressly approved by the party responsible for compliance could void the user's authority to operate this equipment.**

**IMPORTANT: To satisfy exposure compliance requirements, the antenna and transmitter in the console must be at least 8 in. (20 cm) from all persons and must not be near or connected to any other antenna or transmitter.**

**Note: The console contains either FCC ID: OMCBBICON14 or FCC ID: OMCBMD1.**

# HOW TO FOLD AND MOVE THE TREADMILL

## HOW TO FOLD THE TREADMILL

Before folding the treadmill, remove the key and unplug the power cord. **CAUTION:** You must be able to safely lift 45 lbs. (20 kg) to raise, lower, or move the treadmill.

1. Hold the metal frame firmly in the location shown by the arrow below. **CAUTION: Do not hold the frame by the plastic foot rails. Bend your legs and keep your back straight.** Raise the frame about halfway to the vertical position.

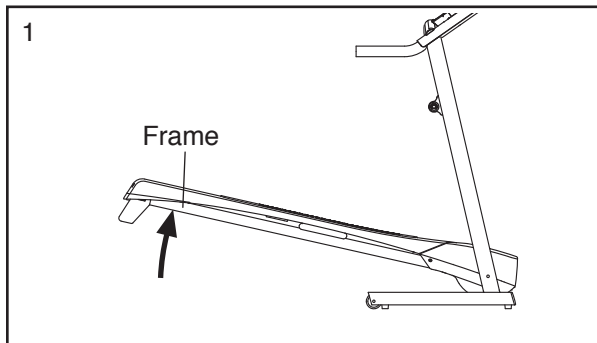

2. Hold the treadmill firmly with your right hand. Pull the latch knob to the left and hold it. Raise the frame until the latch plate is past the latch pin. Then, slowly release the latch knob; **make sure that the latch plate is resting against the latch pin.**

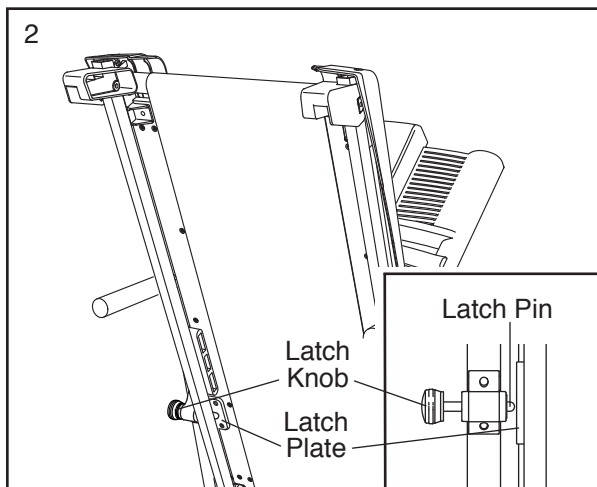

To protect the floor or carpet, place a mat under the treadmill. Keep the treadmill out of direct sunlight. Do not leave the treadmill in the storage position in temperatures above 85°F (30°C).

## HOW TO MOVE THE TREADMILL

Before moving the treadmill, fold it as described at the left. **CAUTION: Make sure that the latch plate is resting against the latch pin. Moving the treadmill may require two people.**

1. Hold the frame and one of the handrails, and place one foot against a wheel.

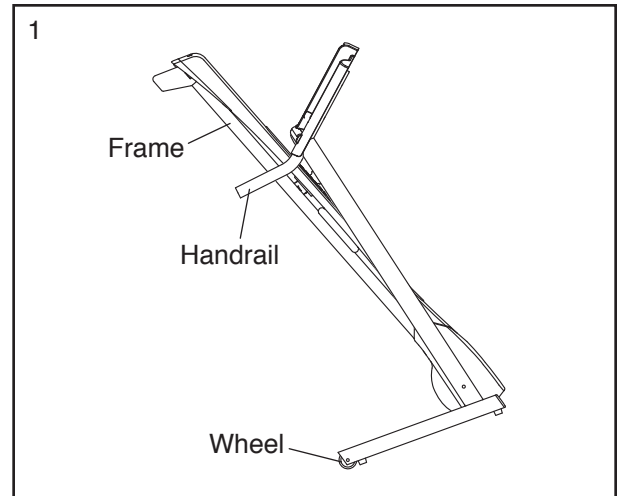

2. Pull back on the handrail until the treadmill will roll on the wheels, and carefully move it to the desired location. **CAUTION: Do not move the treadmill without tipping it back, do not pull on the frame, and do not move the treadmill over an uneven surface.**
3. Place one foot against a wheel, and carefully lower the treadmill.

## HOW TO LOWER THE TREADMILL FOR USE

1. **See drawing 2.** Hold the upper end of the treadmill with your right hand as shown. Pull the latch knob to the left and hold it. Next, lower the frame until it is past the latch pin. Then, release the latch knob.
2. **See drawing 1 at the left.** Hold the metal frame firmly with both hands, and lower it to the floor. **CAUTION: Do not hold the frame by the plastic foot rails, and do not drop the frame. Bend your legs and keep your back straight.**

# MAINTENANCE AND TROUBLESHOOTING

## MAINTENANCE

Regular maintenance is important for optimal performance and to reduce wear. Inspect and properly tighten all parts each time the treadmill is used.

Regularly clean the treadmill and keep the walking belt clean and dry. First, **press the power switch into the off position and unplug the power cord.** Wipe exterior parts of the treadmill with a damp cloth and a small amount of mild soap. **IMPORTANT: Do not spray liquids directly onto the treadmill. To avoid damage to the console, keep liquids away from the console.** Then, thoroughly dry the treadmill with a soft towel.

## TROUBLESHOOTING

**Most treadmill problems can be solved by following the simple steps below. Find the symptom that applies, and follow the steps listed. If further assistance is needed, see the front cover of this manual.**

### **SYMPTOM: The power does not turn on**

- a. Make sure that the power cord is plugged into a surge suppressor and that the surge suppressor is plugged into a properly grounded outlet (see page 12). Use only a surge suppressor that meets all of the specifications described on page 12. **IMPORTANT: If the treadmill is connected to an AFCI-equipped outlet and your circuit breaker trips repeatedly when the treadmill is used, see the front cover of this manual to purchase an arc filter.**

- b. After the power cord has been plugged in, make sure that the key is inserted into the console.
- c. Check the power switch located on the treadmill frame near the power cord. If the switch protrudes as shown, the switch has tripped. To reset the power switch, wait for five minutes and then press the switch back in.

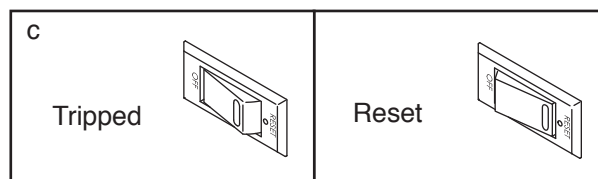

### **SYMPTOM: The power turns off during use**

- a. Check the power switch (see the drawing above). If the switch has tripped, wait for five minutes and then press the switch back in.
- b. Make sure that the power cord is plugged in. If the power cord is plugged in, unplug it, wait for five minutes, and then plug it back in.
- c. Remove the key from the console, and then reinsert it.
- d. If the treadmill still will not run, please see the front cover of this manual.

**SYMPTOM: The walking belt slows when walked on**

- a. Use only a surge suppressor that meets all of the specifications described on page 12.
- b. If the walking belt is overtightened, treadmill performance may decrease and the walking belt may become damaged. Remove the key and **UNPLUG THE POWER CORD**. Using the hex key, turn both idler roller screws counterclockwise, 1/4 of a turn. When the walking belt is properly tightened, you should be able to lift each edge of the walking belt 2 to 3 in. (5 to 7 cm) off the walking platform. Be careful to keep the walking belt centered. Then, plug in the power cord, insert the key, and walk on the treadmill for a few minutes. Repeat until the walking belt is properly tightened.

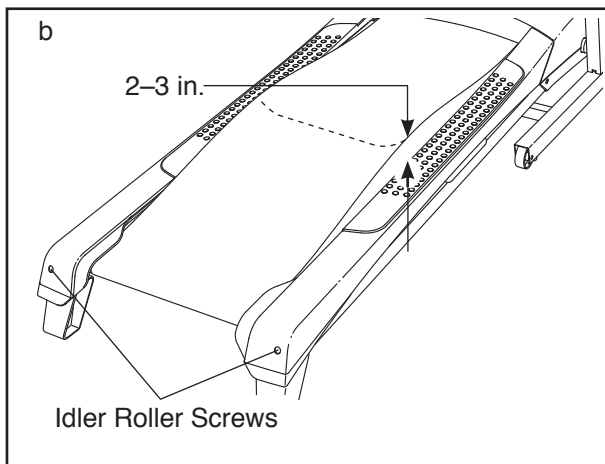

- c. Your treadmill features a walking belt coated with high-performance lubricant. **IMPORTANT: Never apply silicone spray or other substances to the walking belt or the walking platform unless instructed to do so by an authorized service representative. Such substances may deteriorate the walking belt and cause excessive wear.** If you suspect that the walking belt needs more lubricant, see the front cover of this manual.
- d. If the walking belt still slows when walked on, see the front cover of this manual.

**SYMPTOM: The walking belt is off-center or slips when walked on**

- a. **If the walking belt is off-center**, first remove the key and **UNPLUG THE POWER CORD**. **If the walking belt has shifted to the left**, use the hex key to turn the left idler roller screw clockwise 1/2 of a turn; **if the walking belt has shifted to the right**, turn the left idler roller screw counterclockwise 1/2 of a turn. Be careful not to overtighten the walking belt. Then, plug in the power cord, insert the key, and walk on the treadmill for a few minutes. Repeat until the walking belt is centered.

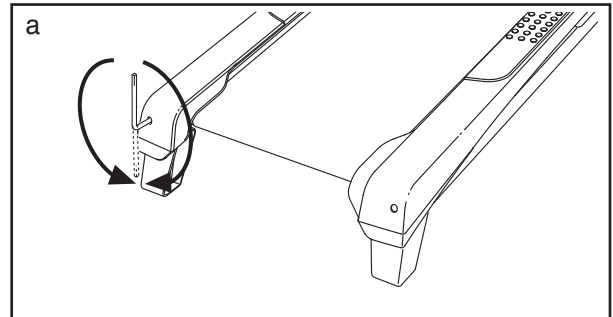

- b. **If the walking belt slips when walked on**, first remove the key and **UNPLUG THE POWER CORD**. Using the hex key, turn both idler roller screws clockwise, 1/4 of a turn. When the walking belt is correctly tightened, you should be able to lift each edge of the walking belt 2 to 3 in. (5 to 7 cm) off the walking platform. Be careful to keep the walking belt centered. Then, plug in the power cord, insert the key, and walk on the treadmill for a few minutes. Repeat until the walking belt is properly tightened.

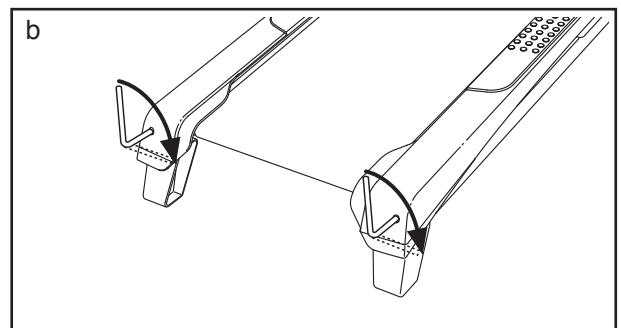

# EXERCISE GUIDELINES

**⚠️ WARNING:** Before beginning this or any exercise program, consult your physician. This is especially important for persons over age 35 or persons with pre-existing health problems.

The heart rate monitor is not a medical device. Various factors may affect the accuracy of heart rate readings. The heart rate monitor is intended only as an exercise aid in determining heart rate trends in general.

These guidelines will help you to plan your exercise program. For detailed exercise information, obtain a reputable book or consult your physician. Remember, proper nutrition and adequate rest are essential for successful results.

## EXERCISE INTENSITY

Whether your goal is to burn fat or to strengthen your cardiovascular system, exercising at the proper intensity is the key to achieving results. You can use your heart rate as a guide to find the proper intensity level. The chart below shows recommended heart rates for fat burning and aerobic exercise.

165	155	145	140	130	125	115	♥♥
145	138	130	125	118	110	103	♥
125	120	115	110	105	95	90	♥
<hr/>							
20	30	40	50	60	70	80	

To find the proper intensity level, find your age at the bottom of the chart (ages are rounded off to the nearest ten years). The three numbers listed above your age define your "training zone." The lowest number is the heart rate for fat burning, the middle number is the heart rate for maximum fat burning, and the highest number is the heart rate for aerobic exercise.

**Burning Fat**—To burn fat effectively, you must exercise at a low intensity level for a sustained period of time. During the first few minutes of exercise, your body uses carbohydrate calories for energy. Only after the first few minutes of exercise does your body begin to use stored fat calories for energy. If your goal is to burn fat, adjust the intensity of your exercise until your heart rate is near the lowest number in your training zone. For maximum fat burning, exercise with your heart rate near the middle number in your training zone.

**Aerobic Exercise**—If your goal is to strengthen your cardiovascular system, you must perform aerobic exercise, which is activity that requires large amounts of oxygen for prolonged periods of time. For aerobic exercise, adjust the intensity of your exercise until your heart rate is near the highest number in your training zone.

## WORKOUT GUIDELINES

**Warming Up**—Start with 5 to 10 minutes of stretching and light exercise. A warm-up increases your body temperature, heart rate, and circulation in preparation for exercise.

**Training Zone Exercise**—Exercise for 20 to 30 minutes with your heart rate in your training zone. (During the first few weeks of your exercise program, do not keep your heart rate in your training zone for longer than 20 minutes.) Breathe regularly and deeply as you exercise; never hold your breath.

**Cooling Down**—Finish with 5 to 10 minutes of stretching. Stretching increases the flexibility of your muscles and helps to prevent post-exercise problems.

## EXERCISE FREQUENCY

To maintain or improve your condition, complete three workouts each week, with at least one day of rest between workouts. After a few months of regular exercise, you may complete up to five workouts each week, if desired. Remember, the key to success is to make exercise a regular and enjoyable part of your everyday life.

# PART LIST

Model No. WLTL29816C.1 R1016A

Key No.	Qty.	Description	Key No.	Qty.	Description
1	4	M10 x 65mm Screw	47	1	Walking Belt
2	6	M8 x 15mm Screw	48	1	Walking Platform
3	30	M4.2 x 19mm Screw	49	1	Right Foot Rail
4	2	M8 x 35mm Screw	50	1	Frame
5	4	M4.2 x 13mm Washer Head Screw	51	1	Right Idler Roller Bracket
6	2	M5 x 16mm Screw	52	1	Right Incline Foot
7	2	#10 x 1" Tek Screw	53	1	Left Incline Foot
8	4	M4.2 x 19mm Tek Screw	54	1	Idler Roller
9	5	M4.2 x 19mm Washer Head Screw	55	1	Left Idler Roller Bracket
10	1	M4.2 x 13mm Bright Screw	56	1	Motor Hood
11	8	M4 x 10mm Screw	57	1	Drive Motor Bracket
12	4	M8 x 30mm Bolt	58	1	Drive Motor
13	4	M4.2 x 13mm Indented Screw	59	1	Electronics Bracket
14	2	M6 x 70mm Screw	60	1	Controller
15	2	1/4" x 3/8" Screw	61	1	Belly Pan
16	1	M8 x 102mm Bolt	62	1	Power Switch
17	2	M8 x 20mm Bolt	63	2	Grommet
18	2	3/8" x 2" Bolt	64	1	Power Cord
19	2	M8 x 40mm Bolt	65	2	8" Tie
20	2	M10 x 110mm Bolt	66	1	Releasable Wire Tie
21	4	M6 Star Washer	67	1	Console Base
22	2	M8.4 Star Washer	68	4	Handrail Cap
23	4	M4.2 Star Washer	69	1	Right Handrail
24	2	Roller Spacer	70	1	Console
25	14	Foot Rail Flat Washer	71	1	Upright Wire
26	4	#8 Flat Washer	72	1	Base
27	2	M10 Star Washer	73	1	Left Upright
28	2	M10 Flat Washer	74	1	Right Upright
29	2	M8 Flange Nut	75	3	Wire Tie
30	2	M10 U-nut	76	2	Frame Spacer
31	1	M8 Jam Nut	77	2	Base Cap
32	2	3/8" Locknut	78	4	Base Pad
33	3	#8 Hood Clip	79	1	Controller Bracket
34	2	M8 Rear Foot Nut	80	1	M6 Nut
35	2	M5 Star Washer	81	1	M6 x 60mm Screw
36	6	M8 Star Washer	82	1	Latch Plate
37	1	Left Foot Rail	83	2	Wheel
38	1	Latch Warning Decal	84	1	Pulse Bar
39	1	Catch	85	2	M4.2 x 25mm Screw
40	2	Platform Cushion	86	1	Left Handrail
41	2	Belt Guide	87	4	Platform Flat Washer
42	1	Storage Latch	88	4	M8 Nut
43	2	1/4" Flat Washer	89	1	Key/Clip
44	1	Upright Grommet	90	4	M4.2 x 16mm Screw
45	1	Drive Belt	91	1	French Warning Decal
46	1	Drive Roller/Pulley	*	—	User's Manual

Note: Specifications are subject to change without notice. For information about ordering replacement parts, see the back cover of this manual. \*These parts are not illustrated.

# EXPLODED DRAWING A

Model No. WLTL29816C.1 R1016A

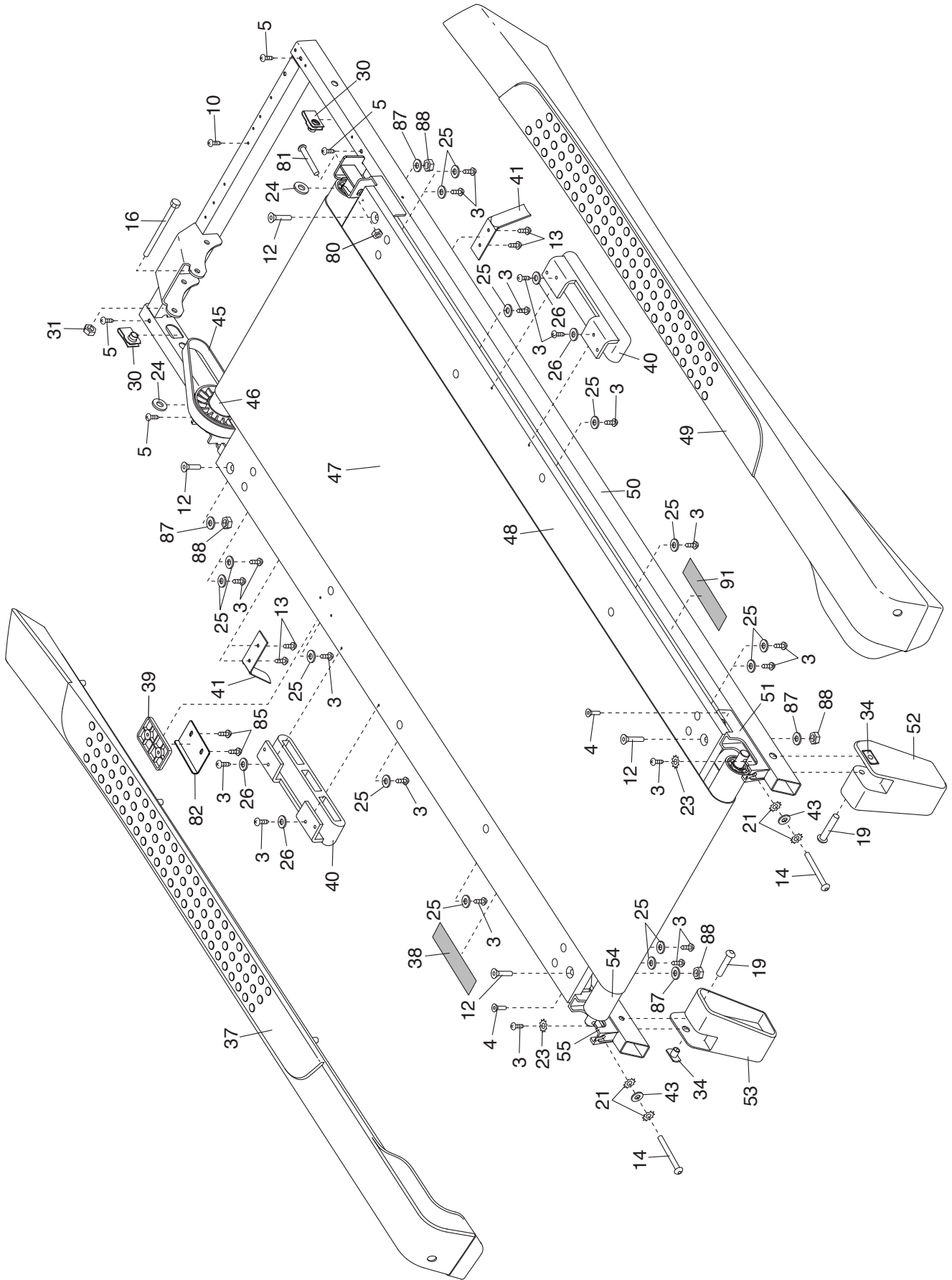

# EXPLODED DRAWING B

Model No. WLTL29816C.1 R1016A

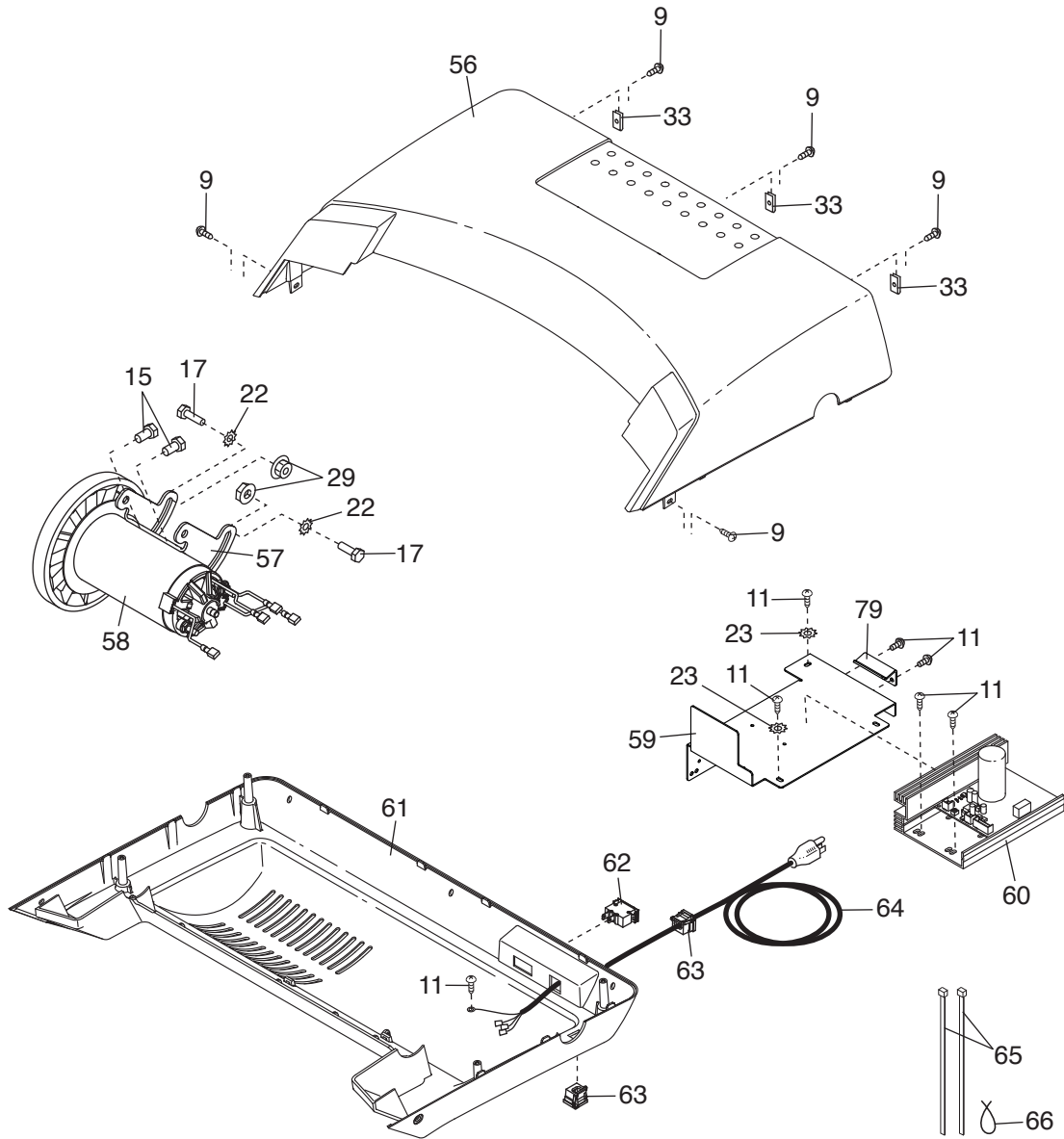

# EXPLODED DRAWING C

Model No. WLTL29816C.1 R1016A

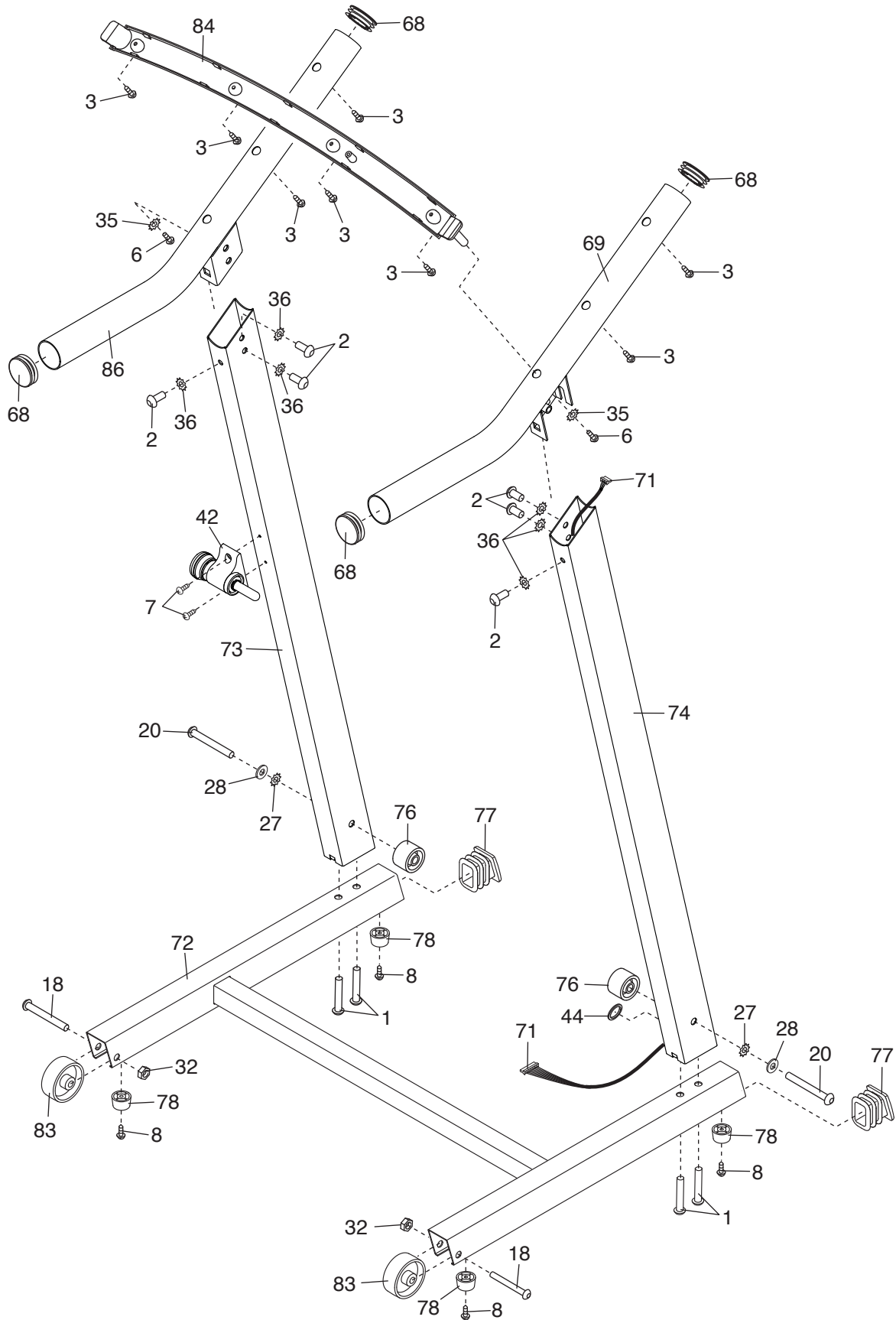

# EXPLODED DRAWING D

Model No. WLTL29816C.1 R1016A

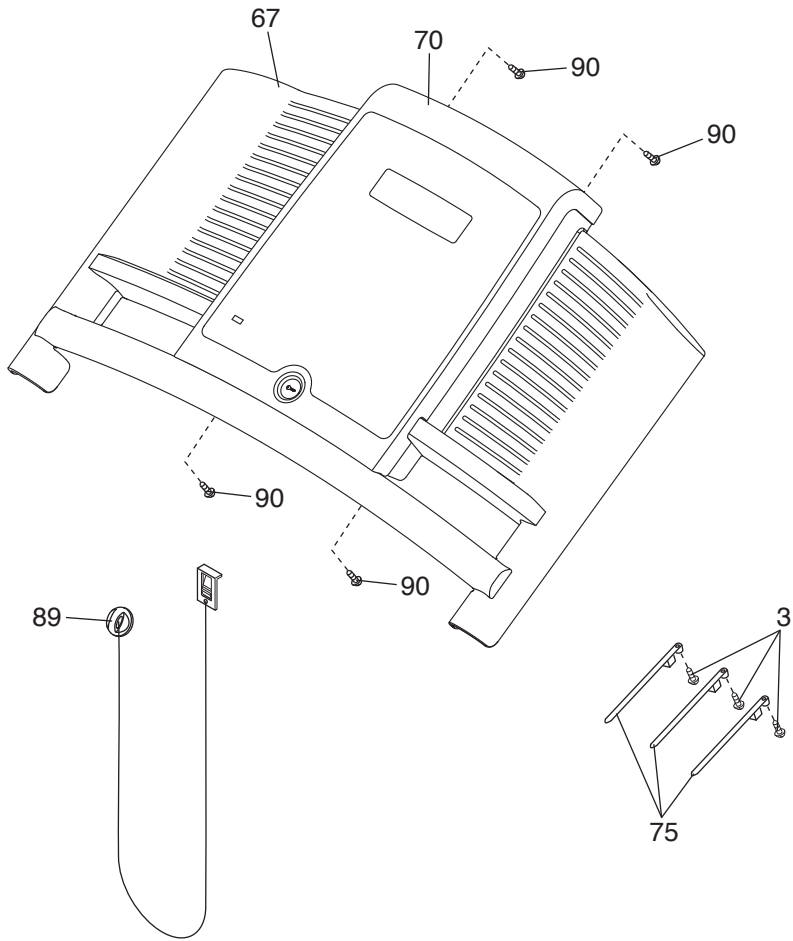

---

# ORDERING REPLACEMENT PARTS

To order replacement parts, please see the front cover of this manual. To help us assist you, be prepared to provide the following information when contacting us:

- the model number and serial number of the product (see the front cover of this manual)
- the name of the product (see the front cover of this manual)
- the key number and description of the replacement part(s) (see the PART LIST and the EXPLODED DRAWING near the end of this manual)

## LIMITED WARRANTY

**IMPORTANT: To protect your fitness equipment with an extended service plan, see page 5.**

ICON of Canada, Inc. (ICON) warrants this product to be free from defects in workmanship and material, under normal use and service conditions. The drive motor is warranted for one (1) year from the date of purchase. Parts and Labor are warranted for ninety (90) days from the date of purchase.

This warranty extends only to the customer. ICON's obligation under this warranty is limited to repairing or replacing, at ICON's option, the product through one of its authorized service centers. All repairs for which warranty claims are made must be preauthorized by ICON. If the product is shipped to a service center, freight charges to and from the service center will be the customer's responsibility. If replacement parts are shipped while the product is under warranty, the customer will be responsible for a minimal handling charge. For in-home service, the customer will be responsible for a minimal trip charge. This warranty does not extend to freight damage to the product. This warranty will automatically be voided if the product is used as a store display model, if all instructions in this manual are not followed, if the product is abused or improperly or abnormally used, or if the product is used for commercial or rental purposes. No other warranty beyond that specifically set forth above is authorized by ICON.

ICON is not responsible or liable for indirect, special, or consequential damages arising out of or in connection with the use or performance of the product; damages with respect to any economic loss, loss of property, loss of revenues or profits, loss of enjoyment or use, or costs of removal or installation; or other consequential damages of any kind. Some provinces do not allow the exclusion or limitation of incidental or consequential damages. Accordingly, the above limitation may not apply to the customer.

The warranty extended hereunder is in lieu of any and all other warranties, and any implied warranties of merchantability or fitness for a particular purpose are limited in their scope and duration to the terms set forth herein. Some provinces do not allow limitations on how long an implied warranty lasts. Accordingly, the above limitation may not apply to the customer.

This warranty provides specific legal rights; the customer may have other rights that vary from province to province.

**ICON of Canada, Inc., 900 de l'Industrie, St. Jérôme, QC J7Y 4B8**