

Installation

80+

Single Stage

Instructions

NTG3/FBF & NTC6/GNE

NTN3/NBF & NTN6/NNE

NDN3/NDF & NDN6/GDE

SAFETY REQUIREMENTS

Recognize safety information. This is the safety-alert symbol . When you see this symbol on the furnace and in instructions manuals be alert to the potential for personal injury.

Understand the signal words *DANGER*, *WARNING*, or *CAUTION*. These words are used with the safety-alert symbol. *DANGER* identifies the most serious hazards, those that **will** result in severe personal injury or death. *WARNING* signifies a hazard that **could** result in personal injury or death. *CAUTION* is used to identify unsafe practices that **could** result in minor personal injury or product and property damage.

Installing and servicing heating equipment can be hazardous due to gas and electrical components. Only trained and qualified personnel should install, repair, or service heating equipment.

Untrained service personnel can perform basic maintenance functions such as cleaning and replacing air filters. All other operations must be performed by trained service personnel. When working on heating equipment, observe precautions in the literature, on tags, and on labels attached to or shipped with the unit and other safety precautions that may apply.

Follow all safety codes. In the United States, follow all safety codes including the current edition National Fuel Gas Code (NFGC) NFPA No. 54/ANSIZ223.1. In Canada, refer to the current edition of the National Standard Canada CAN/CGA-B149.1- and .2-M91 Natural Gas and Propane Installation Codes (NSCNGPIC). Wear safety glasses and work gloves. Have fire extinguisher available during start-up and adjustment procedures and service calls.

These instructions cover minimum requirements and conform to existing national standards and safety codes. In some instances, these instructions exceed certain local codes and ordinances, especially those that may not have kept up with changing residential construction practices. We require these instructions as a minimum for a safe installation.



Manufactured by:

International Comfort Products Corporation (USA)
Lewisburg, TN USA 37091

Table of Contents

1. Safe Installation Requirements	3	8. Electrical Wiring	15
2. Installation	4	9. Ductwork and Filter (Upflow/Horizontal)	16
3. Combustion & Ventilation Air	7	10. Ductwork and Filter (Downflow)	17
4. Gas Vent Installation	9	11. Checks and Adjustments	19
5. Horizontal Venting	10	12. Furnace Maintenance	21
6. Masonry Chimney Venting with Optional Kit	11	13. Tech Support and Parts	22
7. Gas Supply and Piping	12		



WARNING

Electric Shock Hazard
Turn Off All Power Before Servicing.
Failure to do so can result in death, personal injury and/or property damage.



WARNING

Fire or Explosion hazard.
This furnace is not designed for use in mobile homes, trailers or recreational vehicles.
Such use could result in death, bodily injury and/or property damage.

START-UP CHECK SHEET

(Keep this page for future reference)

Dealer Name: _____

Address: _____

Business Card Here

City, State(Province), Zip or Postal Code: _____

Phone: _____

Owner Name: _____

Address: _____

City, State(Province), Zip or Postal Code: _____

Model Number: _____

Serial Number: _____

Type of Gas: Natural: LP:

Blower Motor H.P.: _____

Supply Voltage: _____

Limit Opens at...(°F) _____ or(°C) _____

Limit Closes at...(°F) _____ or(°C) _____

Which blower speed tap is used?
(Heating) _____ (Cooling) _____

Temperature of Supply Air: (°F) _____ or(°C) _____

Temperature of Return Air: (°F) _____ or(°C) _____

Rise (Supply Temp.-Return Temp.): (°F) _____ or(°C) _____

Filter Type and Size: _____

Fan "Time ON" Setting: _____

Fan "Time OFF" Setting: _____

Manual Gas Shut-Off Upstream
of Furnace/Drip-Leg? YES NO

Dealer Comments: _____

Drip-Leg Upstream of Gas Valve? YES NO

Condensate Drain Connected? YES NO

Condensate Drain Trapped? YES NO

Horizontal Condensate Switch Installed? YES NO

Blower Speed Checked? YES NO

All Electrical Connections Tight? YES NO

Gas Valve OK? YES NO

Measured Line Pressure When Firing Unit: _____

Calculated Firing Rate:(See *Checks and Adjustments* Section), _____

Measured Manifold Pressure: _____

Thermostat OK? YES NO

Subbase Level? YES NO

Anticipator Set? YES NO Set At?: _____

Breaker On? YES NO

Date of Installation: _____

Date of Start-Up: _____

1. Safe Installation Requirements

⚠ WARNING

Installation or repairs made by unqualified persons can result in hazards to you and others. Installation **MUST** conform with local codes or, in the absence of local codes, with codes of all governmental authorities having jurisdiction.

The information contained in this manual is intended for use by a qualified service technician who is experienced in such work, who is familiar with all precautions and safety procedures required in such work, and is equipped with the proper tools and test instruments.

Failure to carefully read and follow all instructions in this manual can result in furnace malfunction, death, personal injury and/or property damage.

NOTE: This furnace is design certified by the American Gas Association and the Canadian Gas Association for installation in the United States and Canada. Refer to the appropriate codes, along with this manual, for proper installation.

- **This furnace is NOT approved for installation in mobile homes, trailers or recreation vehicles.**
- Do **NOT** use this furnace as a construction heater or to heat a building that is under construction.
- Use only the Type of gas approved for this furnace (see **Rating Plate** on unit). Overfiring will result in failure of heat exchanger and cause dangerous operation. (Furnace can be converted to L.P. gas with approved kit.)
- Do **NOT** use open flame to test for gas leak.
- Ensure adequate combustion and ventilation air is provided to the furnace.
- Seal supply and return air ducts.
- The vent system **MUST** be checked to determine that it is the correct type and size.
- Install correct filter type and size.
- Unit **MUST** be installed so electrical components are protected from direct contact with water.
- It is the suggestion of the manufacturer to install fire and carbon monoxide detectors.

Safety Rules

Your unit is built to provide many years of safe and dependable service providing it is properly installed and maintained. However, abuse and/or improper use can shorten the life of the unit and create hazards for you, the owner.

- A. The U.S. Consumer Product Safety Commission recommends that users of gas-burning appliances install carbon monoxide detectors. There can be various sources of carbon monoxide in a building or dwelling. The sources could be gas-fired clothes dryers, gas cooking stoves, water heaters, furnaces, gas-fired fireplaces, wood fireplaces, and several other items. Carbon monoxide can cause serious bodily injury and/or death. Therefore, to help alert people of potentially dangerous carbon monoxide levels, you should have carbon monoxide detectors listed by a nationally recognized agency (e.g. Underwriters Laboratories or International Approval Services) installed and maintained in the building or dwelling (see Note below).

- B. There can be numerous sources of fire or smoke in a building or dwelling. Fire or smoke can cause serious bodily injury, death, and/or property damage. Therefore, in order to alert people of potentially dangerous fire or smoke, you should have fire extinguisher and smoke detectors listed by Underwriters Laboratories installed and maintained in the building or dwelling (see Note below).

Note: The manufacturer of your furnace does not test any detectors and makes no representations regarding any brand or type of detector.

- C. To ensure safe and efficient operation of your unit, you should do the the following:

1. **Thoroughly read this manual and labels on the unit.** This will help you understand how your unit operates and the hazards involved with gas and electricity.
2. **Do not use this unit if any part has been under water.** Immediately call a qualified service technician to inspect the unit and to replace any part of the control system and any gas control which has been under water.
3. **Never obstruct the vent grilles, or any ducts that provide air to the unit.** Air must be provided for proper combustion and ventilation of flue gases.

Carbon monoxide or "CO" is a colorless and odorless gas produced when fuel is not burned completely or when the flame does not receive sufficient oxygen.

Freezing Temperatures and Your Structure

⚠ WARNING

Freeze warning.
Turn off water system.

If your unit remains shut off during cold weather the water pipes could freeze and burst, resulting in serious water damage.

Your unit is equipped with safety devices that may keep it from operating if sensors detect abnormal conditions such as clogged exhaust flues.

If the structure will be unattended during cold weather you should take these precautions.

1. Turn off main supply water into the structure and drain the water lines if possible. Open faucets in appropriate areas.
2. Have someone check the structure frequently during cold weather to make sure it is warm enough to prevent pipes from freezing. Suggest they call a qualified service agency, if required.

2. Installation

⚠ WARNING

Poison carbon monoxide gas hazard.

If this furnace is replacing a previously common-vented furnace, it may be necessary to resize the existing vent line and chimney to prevent oversizing problems for the other remaining appliances(s). See applicable codes and *Venting and Combustion Air Check* in *Gas Vent Installation* section.

Failure to properly vent this furnace or other appliances can result in death, personal injury and/or property damage.

Location and Clearances

If furnace is a replacement, it is usually best to install the furnace where the old one was. Choose the location or evaluate the existing location based upon the minimum clearance and furnace dimensions (**Figure 1**, **Figure 2** and **Figure 3**).

CAUTION

Do NOT operate furnace in a corrosive atmosphere containing chlorine, fluorine or any other damaging chemicals. Refer to *Combustion & Ventilation Air* section, *Contaminated Combustion Air*.

Figure 1

Dimensions and Clearances (Upflow/Horizontal NTG3/NTN3 & FBF/NBF)

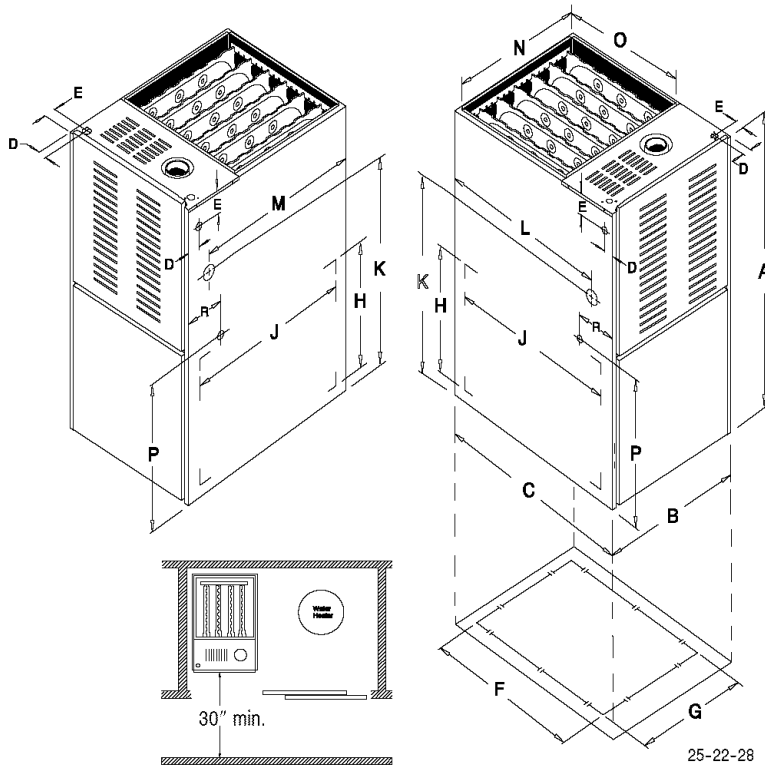

MINIMUM CLEARANCES TO COMBUSTIBLE MATERIALS FOR ALL UNITS	
REAR	0
FRONT	3" *
Recommended For Service	30"
ALL SIDES OF SUPPLY PLENUM	1"
SIDES	0
VENT	
Single Wall Vent	6"
Type B-1 Double Wall Vent	1"
TOP OF FURNACE	1"

* 6" with accessory Masonry Chimney drafthood kit installed.

Drawing is representative some models may vary

DIMENSIONAL INFORMATION

Unit Capacity NTG3/NTN3 FBF/NBF	Cabinet			Electrical Connections						Supply Air		Return Air				Gas Connections			
				Top		Left/Right Side		Low Volt				Bottom		Side		Right Side		Left Side	
	A	B	C	D	E	D	E	R	P	O	N	F	G	J	H	M	K	L	K
50FB / 050B12 75FB / 075B12	40	15 ¹ / ₂	28 ¹ / ₂	1 ¹ / ₂	1 ¹ / ₂	1 ⁵ / ₈	1 ¹ / ₂	4 ¹ / ₂	17 ⁵ / ₁₆	18 ¹ / ₂	14	23 ¹ / ₈	12 ⁵ / ₈	22 ¹ / ₂	12 ¹ / ₄	23 ⁷ / ₈	28 ¹ / ₄	26	28 ¹ / ₄
75HF / 075F16 100KF / 100F20	40	19 ¹ / ₈	28 ¹ / ₂	1 ¹ / ₂	1 ¹ / ₂	1 ⁵ / ₈	1 ¹ / ₂	4 ¹ / ₂	17 ⁵ / ₁₆	18 ¹ / ₂	17 ⁵ / ₈	23 ¹ / ₈	14 ³ / ₄	22 ¹ / ₂	14 ¹ / ₂	23 ⁷ / ₈	28 ¹ / ₄	26	28 ¹ / ₄
100KJ / 100J20 125KJ / 125J20	40	22 ³ / ₄	28 ¹ / ₂	1 ¹ / ₂	1 ¹ / ₂	1 ⁵ / ₈	1 ¹ / ₂	4 ¹ / ₂	17 ⁵ / ₁₆	18 ¹ / ₂	21 ¹ / ₄	23 ¹ / ₈	18 ³ / ₄	22 ¹ / ₂	14 ¹ / ₂	23 ⁷ / ₈	28 ¹ / ₄	26	28 ¹ / ₄

Figure 2

Upflow Dimensions and Clearances (NTC6/GNE & NTN6/NNE)

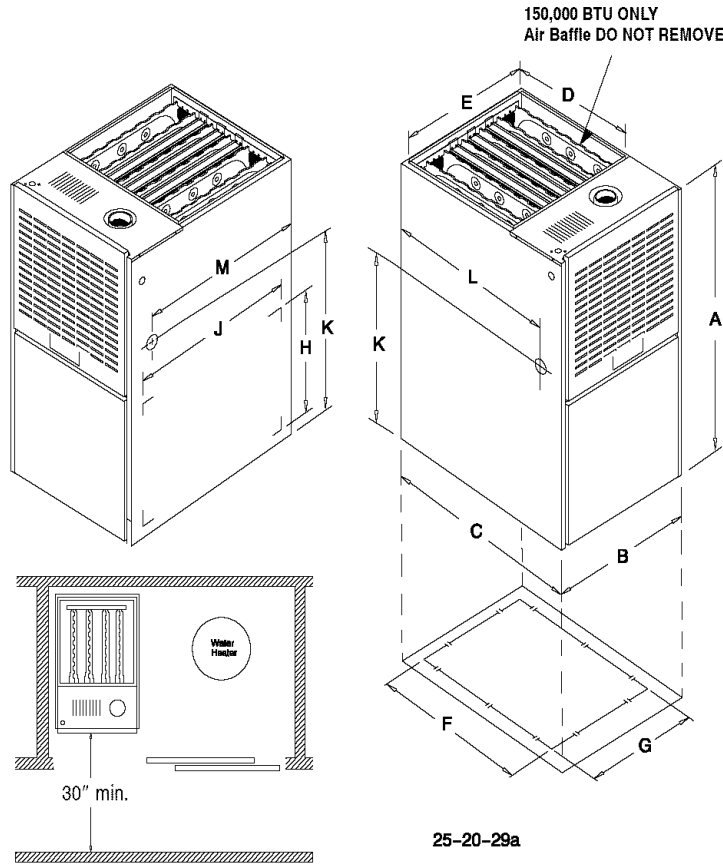

MINIMUM CLEARANCES TO COMBUSTIBLE MATERIALS FOR ALL UNITS	
REAR	0
FRONT	3" (75mm)*
Recommended For Service	30" (760mm)
ALL SIDES OF SUPPLY PLENUM	1" (25mm)
SIDES	0
VENT	
Single Wall Vent	6" (150mm)
Type B-1 Double Wall Vent	1" (25mm)
TOP OF FURNACE	6" (150mm)

* 6" with accessory Masonry Chimney draft hood kit installed.

DIMENSIONAL INFORMATION

Drawing is representative some models may vary

MODEL	CABINET			SUPPLY AIR		RETURN AIR				GAS CONNECTION		
						BOTTOM		SIDE				
	A	B	C	D	E	F	G	H	J	K	L	M
050FB / 075FB 050B12 / 075B12	40	15 ¹ / ₂	28 ¹ / ₂	18 ¹ / ₂	14	23 ¹ / ₈	12 ⁵ / ₈	12 ¹ / ₄	22 ¹ / ₂	28 ¹ / ₄	26	23 ⁷ / ₈
075HF & 075F16 100KF / 100F20	40	19 ¹ / ₈	28 ¹ / ₂	18 ¹ / ₂	17 ⁵ / ₈	23 ¹ / ₈	14 ³ / ₄	14 ¹ / ₂	22 ¹ / ₂	28 ¹ / ₄	26	23 ⁷ / ₈
100KJ / 100J20 125KJ / 125J20 150KJ / 150J20	40	22 ³ / ₄	28 ¹ / ₂	18 ¹ / ₂	21 ¹ / ₄	23 ¹ / ₈	18 ³ / ₄	14 ¹ / ₂	22 ¹ / ₂	28 ¹ / ₄	26	23 ⁷ / ₈

Figure 3

Dimensions and Clearances (Downflow)

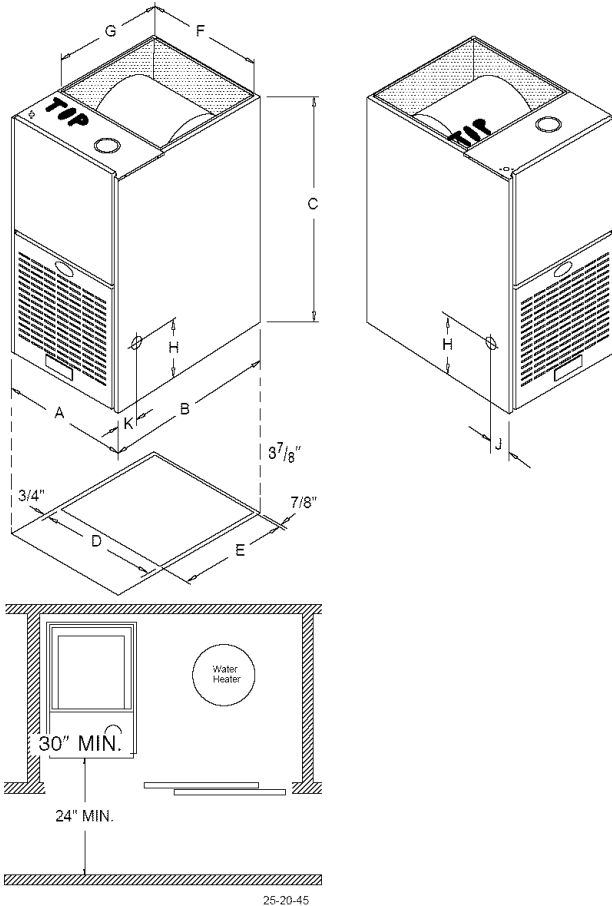

MINIMUM CLEARANCES TO COMBUSTIBLE MATERIALS FOR ALL UNITS	
REAR	0
FRONT	3"
For Service	30"
ALL SIDES OF SUPPLY PLENUM	1"
SIDES	0
VENT	
Single Wall Vent	6"
Type B-1 Double Wall Vent	1"
TOP OF FURNACE	1"

DIMENSIONAL INFORMATION

Drawing is representative some models may vary

MODEL	CABINET			BOTTOM OPENING		RETURN OPENING		GAS CONNECTIONS		
	A	B	C	D	E	F	G	H	J	K
NDN3050/075FB NDF050/075B	15 ¹ / ₂	28 ¹ / ₂	40	14	15 ¹ / ₂	14	18 ¹⁷ / ₃₂	9 ⁷ / ₁₆	2 ¹ / ₂	4 ¹¹ / ₁₆
NDN3075HF & 100GF/KF NDF075F/100F	19 ¹ / ₈	28 ¹ / ₂	40	17 ⁹ / ₁₆	15 ¹ / ₂	17 ⁵ / ₈	18 ¹⁷ / ₃₂	9 ⁷ / ₁₆	2 ¹ / ₂	4 ¹¹ / ₁₆
NDN3125KJ/NDF125J	22 ³ / ₄	28 ¹ / ₂	40	21 ³ / ₁₆	15 ¹ / ₂	21 ¹ / ₄	18 ¹⁷ / ₃₂	9 ⁷ / ₁₆	2 ¹ / ₂	4 ¹¹ / ₁₆

MODEL	CABINET			BOTTOM OPENING		RETURN OPENING		GAS CONNECTIONS		
	A	B	C	D	E	F	G	H	J	K
NDN6050/075FB GDE050/075B	15 ¹ / ₂	28 ¹ / ₂	40	14	15 ¹ / ₂	14	18 ¹⁷ / ₃₂	9 ¹³ / ₁₆	2 ¹ / ₂	4 ¹¹ / ₁₆
NDN6075HF & NDN6100GF/KF GDE075F/100F	19 ¹ / ₈	28 ¹ / ₂	40	17 ⁹ / ₁₆	15 ¹ / ₂	17 ⁹ / ₁₆	18 ¹⁷ / ₃₂	9 ¹³ / ₁₆	2 ¹ / ₂	4 ¹¹ / ₁₆
NDN6125KJ/GDE125J	22 ³ / ₄	28 ¹ / ₂	40	21 ³ / ₁₆	15 ¹ / ₂	21 ³ / ₁₆	18 ¹⁷ / ₃₂	9 ¹³ / ₁₆	2 ¹ / ₂	4 ¹¹ / ₁₆

Installation Requirements

1. Install furnace level.
2. This furnace is **NOT** to be used for temporary heat of buildings or structures under construction.
3. Install the vent pipes as short as practical. (See **Gas Vent Installation** section).
4. Do **NOT** install furnace directly on carpeting, tile or other combustible material other than wood flooring.
5. Maintain clearance for fire safety and servicing. A front clearance of 30" is minimum for access to the burner, controls and filter.
6. Use a raised base if the floor is damp or wet at times.
7. Residential garage installations require:
 - Burners and ignition sources installed at least 18" (457mm) above the floor.
 - Furnace must be located or physically protected from possible damage by a vehicle.

Horizontal Furnace Installation

IMPORTANT

NOTE: Inspect unit rating plate to be certain model number begins with “NTN3”, “FBF”, “NTG3”, “NBF”, “NTC6”, “GNE”, “NTN6” or “NNE”. This identifies unit as horizontally mountable. If unit does **NOT** bear this designation, you may **NOT** mount this unit horizontally. **Horizontal furnace may not be mounted on its back.**

If you purchased a horizontally mountable furnace, it can be installed horizontally in an attic, basement, crawl space, alcove, or suspended from a ceiling in a basement or utility room in either a right or left airflow position. See **Figure 4**.

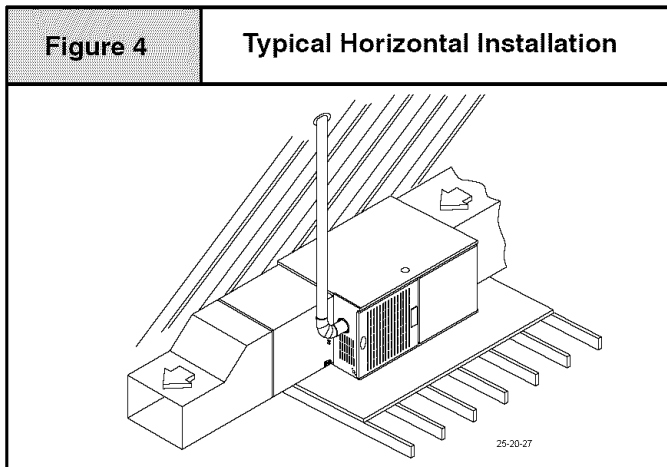

The following minimum clearances to combustibles **MUST** be maintained between the furnace and adjacent construction, as shown in **Figure 1**. **ONLY** the corner of the cabinet is allowed to contact the rafters (see **Figure 4**). All other clearances **MUST** be observed as shown in **Figure 1**.

If the furnace is to be suspended from the floor joists in a crawl space or the rafters in an attic, it is necessary to use steel pipe straps or an angle iron frame to attach the furnace. These straps should be attached to the furnace with sheet metal screws and to the rafters or joists with bolts. The preferred method is to use an angle iron frame bolted to the rafters or joists.

If the furnace is to be installed ground level in a crawl space, consult local codes. A concrete pad 1” to 2” thick is recommended.

3. Combustion & Ventilation Air

⚠ WARNING

Poison carbon monoxide gas hazard.

Use methods described here to provide combustion and ventilation air.

Failure to provide adequate combustion and ventilation air can result in death and/or personal injury.

Furnaces require ventilation openings to provide sufficient air for proper combustion and ventilation of flue gases. All duct or openings for supplying combustion and ventilation air must comply

Thirty inches (30”) is recommended between the front of the furnace and adjacent construction or other appliances. This should be maintained for service clearance.

Keep all insulating materials clear from louvered door. Insulating materials may be combustible.

The horizontal furnaces may be installed directly on combustible wood flooring or supports, however, it is recommended for further fire protection cement board or sheet metal is placed between the furnace and the combustible wood floor and extend 12” beyond the front of the furnace louver door. (This is a recommendation only, not a requirement).

This furnace **MUST NOT** be installed directly on wood flooring or supports, carpeting, tile or other combustible material other than wood flooring.

Pressure Switch Relocation

If the furnace is installed in a right to left airflow position (left side of furnace facing down), the pressure switch will remain in the same position as installed by the factory (see **Figure 5**). If the furnace is installed in a left to right airflow position (right side of furnace facing down), the pressure switch **MUST** be relocated to the left side of the furnace using the holes provided in the top panel. Position the pressure switch in the same orientation as the original location. To prevent possible kinking of the pressure switch hose, trim the hose to remove excess.

Note: Care **MUST** be taken not to cut the tube too short.

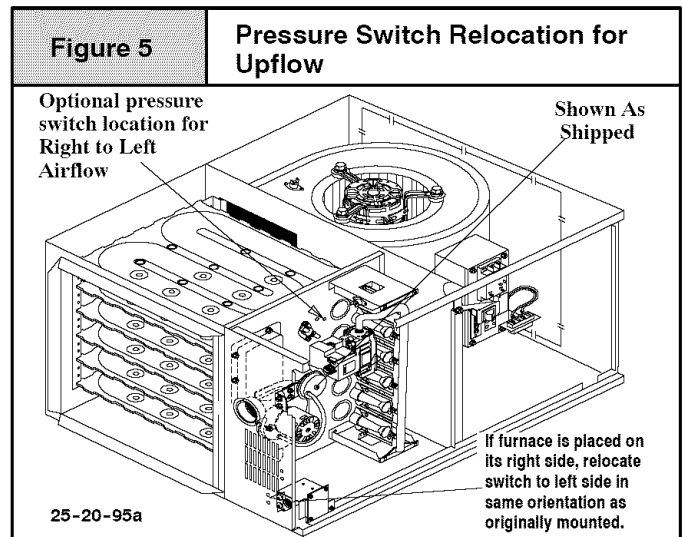

with the gas codes, or in the absence of local codes, the applicable national codes.

When the installation is complete, check that all appliances have adequate combustion air and are venting properly. See *Venting And Combustion Air Check* in “Gas Vent Installation” Section in this manual.

Contaminated Combustion Air

Installations in certain areas or types of structures will increase the exposure to chemicals or halogens that may harm the furnace. These instances must use only outside air for combustion.

The following areas or types of structures may contain or have exposure to the substances listed below. The installation must be evaluated carefully as it may be necessary to provide outside air for combustion.

- Commercial buildings.
- Buildings with indoor pools.
- Furnaces installed in laundry rooms.
- Furnaces installed in hobby or craft rooms.
- Furnaces installed near chemical storage areas.
- Permanent wave solutions for hair.
- Chlorinated waxes and cleaners.
- Chlorine based swimming pool chemicals.
- Water softening chemicals.
- De-icing salts or chemicals.
- Carbon tetrachloride.
- Halogen type refrigerants.
- Cleaning solvents (such as perchloroethylene).
- Printing inks, paint removers, varnishes, etc.
- Hydrochloric acid.
- Sulfuric Acid.
- Solvent cements and glues.
- Antistatic fabric softeners for clothes dryers.
- Masonry acid washing materials.

Confined Space Installation

NOTE: A confined space is defined as an area with less than 50 cubic feet per 1,000 BTUH input rating for all gas appliances installed in the area.

Air Openings and Connecting Ducts

1. Total input rating for all gas appliances **MUST** be considered when determining free area of openings.
2. Connect ducts or openings directly to outside.
3. When screens are used to cover openings, the openings **MUST** be no smaller than 1/4" mesh.
4. The minimum dimension of rectangular air ducts **MUST NOT** be less than 3" .
5. When sizing grille or louver, use the free area of opening. If free area is **NOT** stamped or marked on grill or louver, assume a 20% free area for wood and 60% for metal.

Requirements

1. Provide confined space with sufficient air for proper combustion and ventilation of flue gases using horizontal or vertical ducts or openings.
2. **Figure 6** illustrates how to provide combustion and ventilation air. A minimum of two permanent openings, one inlet and one outlet, are required.

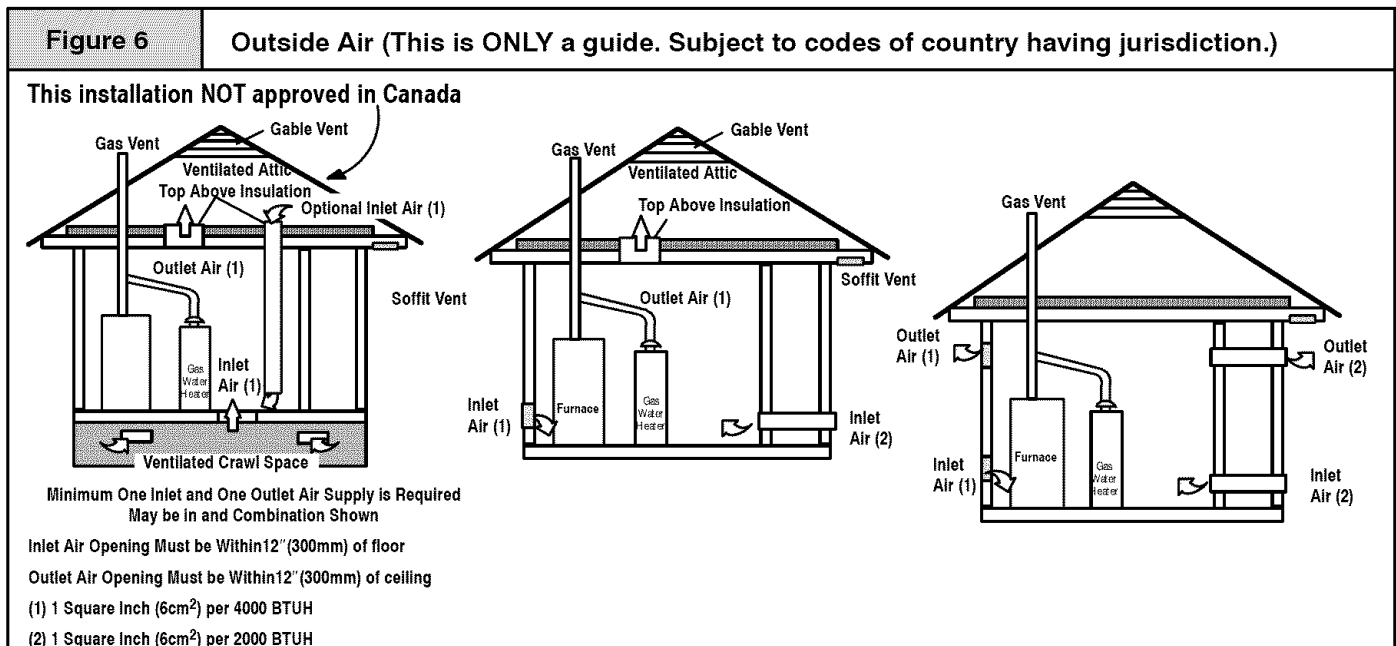

3. One opening **MUST** be within 12" of the floor and the second opening within 12" of the ceiling.
4. Size openings and ducts per **Table 1**.
5. Horizontal duct openings require 1 square inch of free area per 2,000 BTUH of combined input for all gas appliances in area (see **Table 1**).
6. Vertical duct openings or openings directly to outside require 1 square inch of free area per 4,000 BTUH for combined input of all gas appliances in area (see **Table 1**).

One permanent opening, commencing within 12" of the top of the enclosure, shall be permitted where the equipment has clearances of at least 1" from the sides and back and 6" from the front of the appliance. The opening shall directly communicate with the outdoors or shall communicate through a vertical or horizontal duct to the outdoors or spaces (crawl or attic) that freely communicate with the outdoors, and shall have a minimum free area of:

- 1 sq. in per 3000 Btu per hr. of the total input rating of all equipment located in the enclosure, and
- Not less than the sum of the areas of all vent connectors in the confined space.

Table 1		Free Area		
BTUH Input Rating	Minimum Free Area Required for Each Opening			
	Horizontal Duct (sq. in./2,000 BTUH)	Vertical Duct or openings to outside (sq. in./4,000 BTUH)	Rd Duct (sq. in./4,000 BTUH)	
50,000	25 sq. in.	12.5 sq. in.	4"	
75,000	35.5 sq. in.	18.75 sq. in.	5"	
100,000	50 sq. in.	25 sq. in.	6"	
125,000	62.5 sq. in.	31.25 sq. in.	7"	

EXAMPLE: Determining Free Area
Furnace Water Heater Total Input
100,000 + 30,000 = (130,000 ÷ 4,000) = 32.5 Sq. In. Vertical
Furnace Water Heater Total Input
100,000 + 30,000 = (130,000 ÷ 2,000) = 65 Sq. In. Horizontal

Unconfined Space Installation

⚠ WARNING

Poison carbon monoxide gas hazard.
Most homes will require additional air.
An unconfined space or homes with tight construction may not have adequate air infiltration for proper combustion and ventilation of flue gases.
Failure to supply additional air by means of ventilation grilles or ducts could result in death and/or personal injury.

An unconfined space is defined as an area having a minimum volume of 50 cubic feet per 1,000 Btuh total input rating for all gas appliances in area.

4. Gas Vent Installation

⚠ WARNING

Poison carbon monoxide gas, fire and explosion hazard.
Read and follow all instructions in this section.
Failure to properly vent this furnace can result in death, personal injury and/or property damage.

Install the vent in compliance with codes of the country having jurisdiction, local codes or ordinances and these instructions.

These fan assisted combustion furnaces have been classified as Category I appliances which means that they **MUST** operate with a negative vent pressure.

Category I Safe Venting Requirements

NOTE: The following instructions comply with the United States National Fuel Gas Code. Based on the highest input rate on the furnace rating plate.

1. If a Category I vent passes through an attic, any concealed space or floor, use **ONLY** Type B or Type L double wall vent pipe. If vent pipe passes through interior wall, use type B vent pipe with ventilated thimble **ONLY**.

Adjoining rooms can be considered part of an unconfined area if there are no doors between rooms.

An attic or crawl space may be considered an unconfined space provided there are adequate ventilation openings directly to outdoors. Openings **MUST** remain open and **NOT** have any means of being closed off. Ventilation openings to outdoors **MUST** be at least 1 square inch of free area per 4,000 BTUH of total input rating for all gas appliances in area.

In unconfined spaces, infiltration should be adequate to provide air for combustion, ventilation and dilution of flue gases. However, in buildings with unusually tight construction, additional air **MUST** be provided using the methods described in section titled *Confined Space Installation*:

Unusually tight construction is defined as: Construction with

1. Walls and ceilings exposed to the outside have a continuous, sealed vapor barrier. Openings are gasketed or sealed and
2. Doors and openable windows are weather stripped and
3. Other openings are caulked or sealed. These include joints around window and door frames, between sole plates and floors, between wall-ceiling joints, between wall panels, at penetrations for plumbing, electrical and gas lines, etc.

Ventilation Air

Some provincial codes and local municipalities require ventilation or make-up air be brought into the conditioned space as replacement air. Whichever method is used, the mixed return air temperature across the heat exchanger **MUST** not fall below 60°F or flue gases will condense in the heat exchanger. This will shorten the life of the heat exchanger and possibly void your warranty.

2. Do **NOT** vent furnace into any chimney serving an open fireplace or solid fuel burning appliance.
3. Use the same diameter Category I connector or pipe as permitted by the **United States National Fuel Gas Code** venting tables.
4. Keep vertical Category I vent pipe or vent connector runs as short and direct as possible.
5. Vertical outdoor runs of type B or **ANY** single wall vent pipe below the roof line are **NOT** permitted.
6. Slope all horizontal runs up away from furnace a minimum of 1/4" per foot.
7. Support all horizontal vent pipe every 6' using proper clamps and metal straps.
8. Check existing gas vent or chimney to ensure they meet clearances and local codes.
9. The furnace **MUST** be connected to a factory built chimney or vent complying with a recognized standard. **Venting into a masonry or concrete chimney is only permitted as outlined in the United States National Fuel Gas Code venting tables or Masonry Chimney section in these instructions.**

⚠ WARNING

Poison carbon monoxide gas hazard.

If this furnace is replacing a previously common-vented furnace, it may be necessary to resize the existing chimney liner or vent to prevent over sizing problems for the other remaining appliance(s). See codes of country having jurisdiction.

Failure to properly vent this furnace or other appliances can result in property damage, personal injury and/or death.

Venting and Combustion Air Check

NOTE: If this installation removes an existing furnace from a venting system serving one or more other appliances, and to make sure there is adequate combustion air for all appliances, **MAKE THE FOLLOWING CHECK.**

1. Seal any unused openings in the venting system.
2. Visually inspect the venting system for proper size and horizontal pitch to ensure there is no blockage or restriction, leakage, corrosion or other deficiencies which could cause an unsafe condition.
3. Insofar as is practical, close all doors and windows and all doors between the space in which the appliance(s) remaining connected to the venting system are located and other spaces of the building.
4. Turn on clothes dryers and any appliance not connected to the venting system. Turn on any exhaust fans, such as range hoods and bathroom exhausts, so they will operate at maximum speed. Do not operate a summer exhaust fan. Close fireplace dampers.
5. Follow the lighting instructions for each appliance being inspected. Adjust thermostat so appliance(s) will operate continuously.
6. Allow 5 minutes of main burner operation, then check for spillage at the draft hood relief opening of each appliance. Use the flame of a match or candle (**Figure 7**).
7. After it has been determined that each appliance vents properly, return doors, windows, appliances etc. to their normal condition.

5. Horizontal Venting

Category I Furnaces With External Power Venters

In order to maintain a Category I classification of fan assisted furnaces when vented horizontally with sidewall termination, a power venter is **REQUIRED** to maintain a negative pressure in the venting system. Please consult the Fields Controls Co. or Tjernlund Products, Inc. for power venters certified for use with our furnaces.

Vent Termination

Venting Through a Non-Combustible and Combustible Wall

Consult External Power Venter manufacturer instructions.

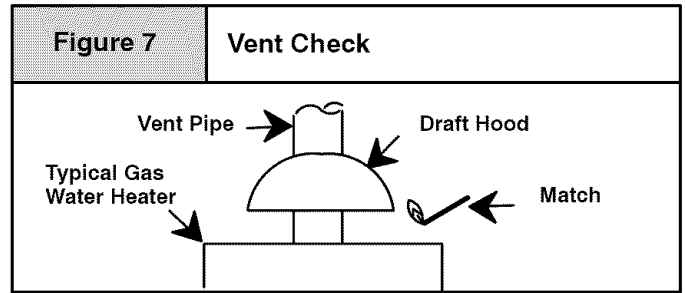

8. If improper venting is observed, the cause **MUST** be corrected.

NOTE: If flame pulls towards draft hood, this indicates sufficient infiltration air.

Venting to Existing Masonry Chimney

NOTE: The tables and notes referred to below are found in the most recent printing of the **United States National Fuel Gas Code** venting tables.

Use the United States National Fuel Gas Code or NFGC Tables to size the chimney or vent. **Dedicated venting of one fan assisted furnace into any masonry chimney is restricted.** The chimney must first be lined with either type B vent sized in accordance with tables 1 or 2 or a listed single wall, metal lining system, sized in accordance with the vent tables: or **(Venting as outlined with use of optional masonry chimney kit as applicable.)** (See Section 5)

Listed, corrugated metallic chimney liner systems in masonry chimneys shall be sized by using **United States National Fuel Gas Code** tables for dedicated venting and **United States National Fuel Gas Code** tables for common venting with the maximum capacity reduced by 20% (0.80 X maximum capacity) and the minimum capacity as shown in the applicable table. Corrugated metal vent systems installed with bends or offsets require additional reduction of 10% of the vent capacity for each 90° elbow.

NOTE: Two(2) 45° elbows are equivalent to one (1) 90° elbow.

Combined Venting into a Masonry Chimney

Venting into a masonry or concrete chimney is only permitted as outlined in the United States National Fuel Gas Code venting tables. Follow all safe venting requirements.

Note: See section "Masonry Chimney Venting".

CAUTION

It is the responsibility of the installer to properly terminate the vent and provide adequate shielding. This is essential in order to avoid water/ice damage to building, shrubs and walk-ways.

6. Masonry Chimney Venting with Optional Kit Upflow/Horizontal (USA ONLY) Not recommended for Downflow Furnaces

Chimney Inspection

All masonry chimney construction must conform to Standard ANSI/NFPA211 and to any state or local codes applicable. The chimney must be in good condition and a complete investigation must be conducted prior to installation. If the inspection reveals damage or abnormal conditions, make necessary repairs or seek expert help. See "The Chimney Inspection Chart". Measure area of tile-liner and exact height of chimney.

Connector Type

To reduce flue gas heat loss and the chance of condensate problems, the vent connector must be double wall Type B vent.

Venting Restrictions for Chimney Types

Interior Chimney - has no sides exposed to the outside below the roofline. All installations can be single furnace or common vented with another draft hood equipped Category I appliance.

Exterior Chimney - has one or more sides exposed to the outside below the roof line. All installations must be common vented only with another draft hood equipped Category I appliance.

Caution - failure to follow these guidelines may cause severe property damage.

Optional Masonry Vent Kit Draft Hood Assy. Installation (See Figure 8)

NOTE: These instructions apply to the NTG3, NTN3, FBF & NBF series furnaces only.

1. Disconnect power and gas supply to furnace.
2. Remove louvered door.
NTG3, NTN3, FBF & NBF Series furnaces - Discard louvered door.
3. NTG3, NTN3, FBF & NBF may be installed upflow or horizontal position per furnace application. When installing NTG3,

NTN3, FBF & NBF furnaces in a horizontal left hand application you will need to mount the pressure switch to the side of the cabinet.

4. NTG3, NTN3, FBF & NBF series furnaces - Detach pressure switch from top panel by removing two screws. Set aside screws.
5. Detach field connect box from top panel by removing two screws. Set aside screws.
6. Remove four screws holding top panel to casing. Remove top panel. Discard top panel. Set screws aside.
7. Install draft hood assy. to casing using four screws previously set aside.
8. Attach field connect box to draft hood assy. using two screws previously set aside.
9. NTG3, NTN3, FBF & NBF Series furnaces - Attach pressure switch to draft hood assy. using two screws previously set aside.

Vent Limit Switch Wiring (See Figure 8)

1. Locate wire harness assy. which is supplied with kit. Attach terminals on one end of wire harness assy. to vent limit switch located on draft hood assy.
2. Locate furnace's main limit. Detach wire with insulated terminal from one side of main limit.
3. Route wire harness assy. from vent limit switch to main limit. Attach female terminal of wire harness assy. to vacated main limit terminal. Attach male terminal of wire harness assy. to insulated terminal of wire previously detached from main limit.

Completion of Installation

1. NTG3, NTN3, FBF & NBF Series furnaces - Locate louvered door supplied with kit. Install on furnace.
2. Refer to installation instructions provided with furnace to put the furnace into operation.

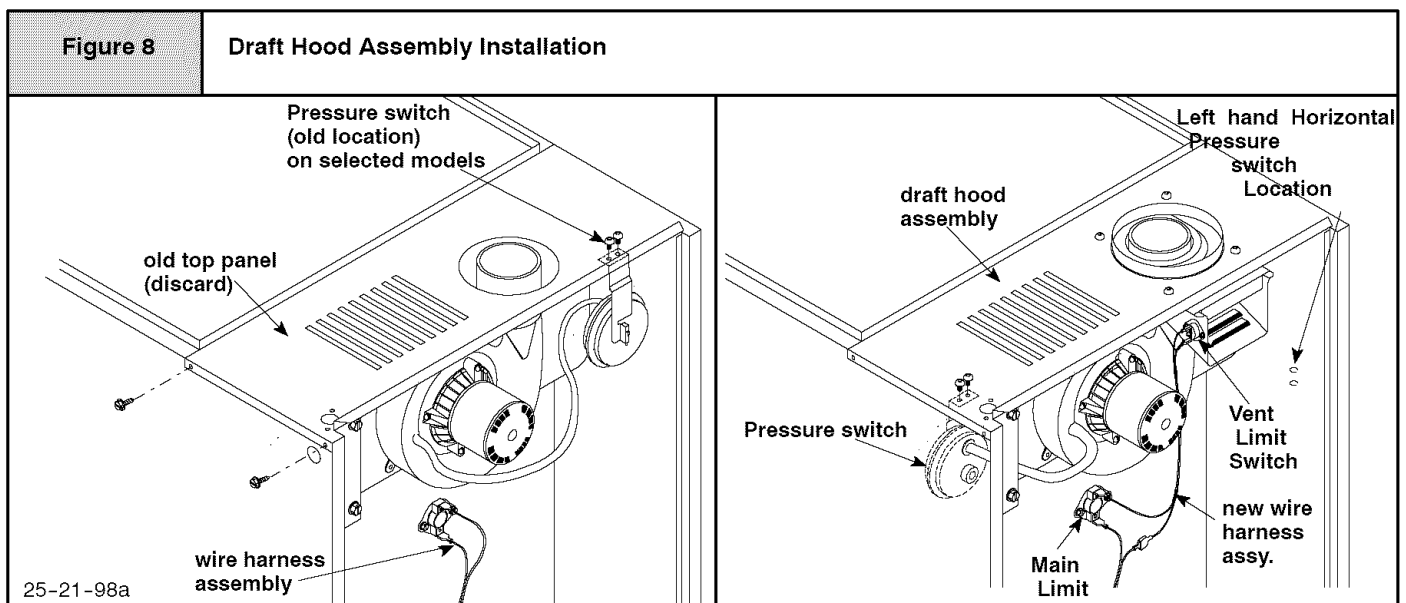

Masonry chimney venting shall be approached as follows: Using **Table 1** and **Table 2** in the masonry chimney draft hood kit instructions, the NFGC Z223.1-1992 or the GAMA Venting Tables.

7. Gas Supply and Piping

⚠ WARNING

Poison carbon monoxide gas, fire and explosion hazard. Models designated for Natural Gas are to be used with Natural Gas ONLY, unless properly converted to use with LP gas.

Failure to follow these instructions can result in death, personal injury and/or property damage.

Gas Supply Requirements

- Use only the Type of gas approved for this furnace. See rating plate for approved gas type.
- Gas input must not exceed the rated input shown on the rating plate. Overfiring will result in failure of heat exchanger and cause dangerous operation.
- Do not allow minimum supply pressure to vary downward. Doing so will decrease input to furnace. Refer to **Table 2** for Gas supply and manifold pressures.

Gas Type	Supply Pressure			Manifold Pressure
	Recommended	Max.	Min.	
Natural	7" (1.7 kPa)	14" (3.5 kPa)	4.5" (1.1 kPa)	3.5" (0.9 kPa)
Propane	11" (2.7 kPa)	14" (3.5 kPa)	11" (2.7 kPa)	10" (2.5 kPa)

Natural Gas Input Rating Check

The gas meter can be used to measure input to furnace. Rating is based on a natural gas BTU content of 1,000 BTU's per cubic foot. Check with gas supplier for actual BTU content.

1. Turn **OFF** gas supply to all appliances other than furnace and start furnace.
2. Time how many seconds it takes the smallest dial on the gas meter to make one complete revolution. Refer to **Example**. **Note:** If meter uses a 2 cubic foot dial, divide results (seconds) by two.

Example			
Natural Gas BTU Content	No. of Seconds Per Hour	Time Per Cubic Foot in Seconds	BTU Per Hour
1,000	3,600	48	75,000
$1,000 \times 3,600 \div 48 = 75,000 \text{ BTUH}$			

3. Relight all appliances and ensure all pilots are operating.

Orifice Sizing

NOTE: Factory sized orifices for natural and LP gas are listed in the furnace Technical Support manual.

Ensure furnace is equipped with the correct main burner orifices. Refer to **Table 3** for correct orifice size for a given heating value and specific gravity for natural and propane gas. Note that this chart is **ONLY** for installations *below* 2000' in altitude.

Gas Type	Manifold Pressure	Specific Gravity	Heating Value (BTU per Cubic Ft.)	Orifice Size (Drill #)
Natural	3.5" w.c. 0.9kPa w.c.	0.6	800	40
			900	41
			1000	42
			1100	43
Propane	10" w.c. 2.5kPa w.c.	1.53	2500	54

Operation Above 2000' Altitude

⚠ WARNING

Fire, Explosion, Poison carbon monoxide gas hazard.

This conversion shall be done by a qualified service agency in accordance with the Manufacturer's instructions and all applicable codes and requirements, or in the absence of local codes, the applicable national codes.

Failure to follow these instructions exactly can result in death, personal injury and/or property damage.

These units may be used at full input rating when installed at altitudes up to 2000'. When installed above 2000', the input must be decreased 2% (natural) or 4% (LP) for each 1000' above sea level. This may be accomplished by a simple adjustment of manifold pressure or an orifice change, or a combination of a pressure adjustment and an orifice change. The changes required depend on the installation altitude and the heating value of the fuel. **Table 4** & **Table 5** show the proper furnace manifold pressure and gas orifice size to achieve proper performance based on elevation above sea level for both natural gas and propane.

To use the natural gas table, first consult your local gas utility for the heating value of the gas supply. Select the heating value on the vertical border and follow across the table until the appropriate elevation for the installation is reached. The first value in the box at the intersection of the heating value and elevation will be the manifold pressure required. If a gas orifice change is also required, the box is shaded. The required orifice size is shown at the bottom of the table.

Sea Level
High Altitude Input Rate = Nameplate x (Multiplier)
Input Rate

Elevation	High Altitude Multiplier	
	Natural	LP Gas
2000' - 2999'	0.96	0.92
3000' - 3999'	0.94	0.88
4000' - 4999'	0.92	0.84
5000' - 5999'	0.90	0.80
6000' - 6999'	0.88	0.76
7000' - 7999'	0.86	0.72

A High Altitude Kit is available for downflow which includes restrictors, orifices and installation instructions.

Natural Gas - 1160993
LP Gas - 1160992

MANIFOLD PRESSURE AND ORIFICE SIZE FOR HIGH ALTITUDE APPLICATIONS

Table 4		NATURAL GAS					
HEATING VALUE BTU/CU. FT.	MEAN ELEVATION FEET ABOVE SEA LEVEL						
	0 to 1999	2000 to 2999	3000 to 3999	4000 to 4999	5000 to 5999	6000 to 6999	7000 to 8000
800	3.5" wc	3.5" wc	3.5" wc	3.5" wc	3.5" wc	3.5" wc	3.5" wc
850	3.5" wc	3.5" wc	3.5" wc	3.5" wc	3.5" wc	3.5" wc	3.5" wc
900	3.5" wc	3.5" wc	3.5" wc	3.5" wc	3.5" wc	3.5" wc	3.4" wc
950	3.5" wc	3.5" wc	3.5" wc	3.5" wc	3.3" wc	3.2" wc	3.1" wc
1000	3.5" wc	3.4" wc	3.3" wc	3.2" wc	3.0" wc	2.9" wc	2.8" wc
1050	3.2" wc	3.1" wc	3.0" wc	2.9" wc	2.7" wc	2.6" wc	2.5" wc
1100	2.9" wc	2.8" wc	2.7" wc	2.6" wc	2.5" wc	2.4" wc	2.3" wc
Orifice Size	#42	#42	#42	#42	#42	#42	#42

Table 5		PROPANE					
HEATING VALUE BTU/CU. FT.	MEAN ELEVATION FEET ABOVE SEA LEVEL						
	0 to 1999	2000 to 2999	3000 to 3999	4000 to 4999	5000 to 5999	6000 to 6999	7000 to 8000
2500	10.0" wc	10.0" wc	9.4" wc	10.0" wc	9.8" wc	8.8" wc	7.9" wc
Orifice Size	#54	#54	#54	#55	#55	#55	#55

NOTE: NATURAL GAS DATA BASED ON 0.60 SPECIFIC GRAVITY. PROPANE DATA BASED ON 1.53 SPECIFIC GRAVITY. FOR FUELS WITH DIFFERENT SPECIFIC GRAVITY CONSULT THE LATEST EDITION OF THE NATIONAL FUEL GAS CODE ANSI Z223.1 and CAN B149.

Changing Orifices

1. After disconnecting power and gas supply to the furnace, remove the access door, exposing the burner compartment.

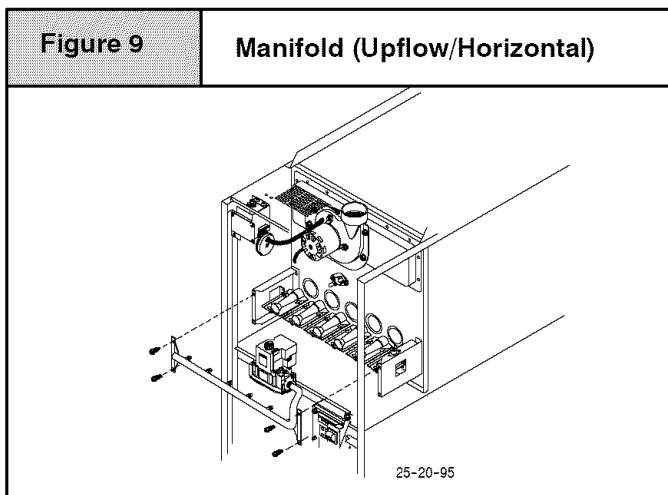

2. Disconnect gas line and pilot tubing from gas valve so manifold can be removed.
3. Disconnect wiring at gas valve. Be sure to note the proper location of any and all electrical wiring disconnected.
4. Remove the four (4) screws holding the manifold and gas valve to the manifold supports. Do not discard any screws. See **Figure 9** or **Figure 10**.
5. Carefully remove the manifold assembly.

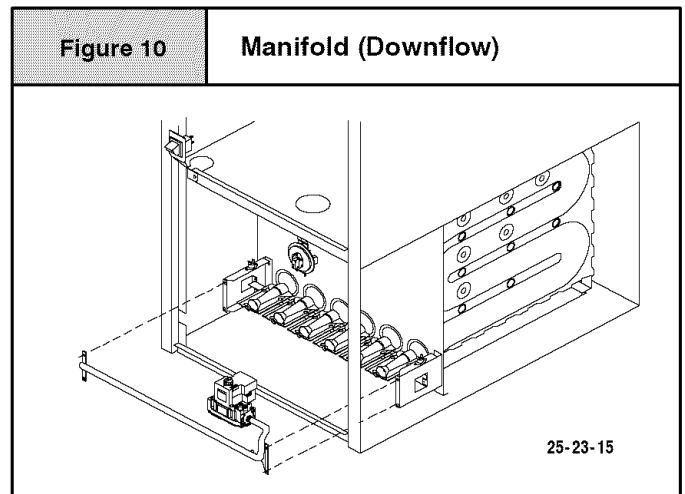

6. Remove the orifices from the manifold and replace them with proper sized orifices. See **Figure 11**.
7. Tighten orifices so it is seated and gas tight. See **Figure 11**.

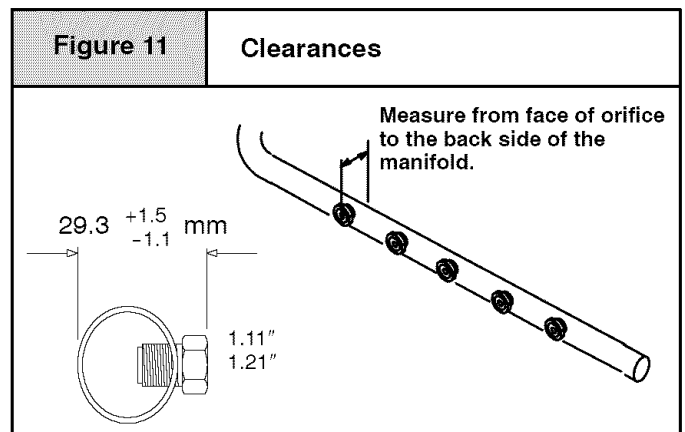

8. Reassemble all parts in reverse order as removed. Be sure to engage the main burner orifices in the proper opening in the burners.
9. After reassembling, turn gas on and check all joints for gas leaks using a soapy solution. All leaks must be repaired immediately.

Gas Piping Requirements

1. Install gas piping in accordance with local codes, or in the absence of local codes, the applicable national codes.
2. It is recommended that a manual shutoff valve be installed in the gas supply line outside the unit. Locate valve as close to the furnace as possible where it is readily accessible. Refer to **Figure 12**.
3. Use black iron or steel pipe and fittings or other pipe approved by local code.
4. Use pipe thread compound which is resistant to natural and LP gases.
5. Install a drip leg no less than 3" long to trap dirt and moisture before it can enter gas valve.
6. Provide a 1/8" inch plug for test gauge connection immediately up stream of gas supply connection to furnace.

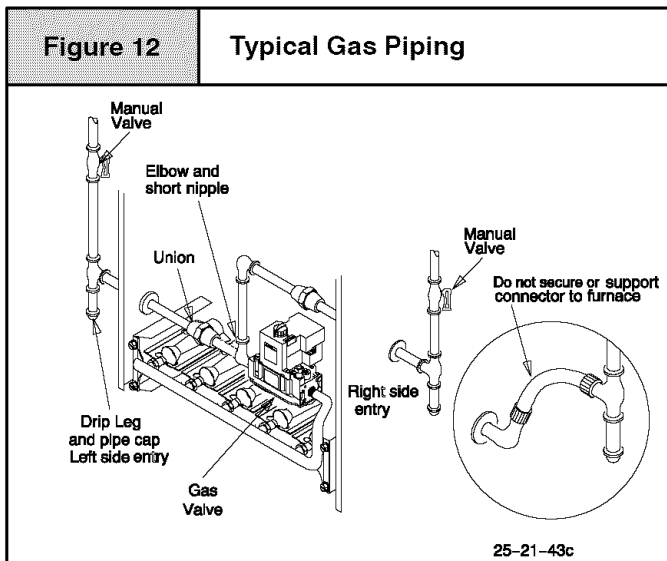

7. Use two pipe wrenches when making connections to prevent gas valve from turning.
8. Flexible corrugated metal gas connector may **NOT** be used inside the furnace or be secured or supported by the furnace or ductwork.
9. Properly size gas pipe to handle combined appliance load or run gas pipe directly from gas meter or LP gas regulator.
10. Install correct pipe size for run length and furnace rating.

11. Measure pipe length from gas meter or LP second stage regulator.

⚠ WARNING

Fire or explosion hazard.

The flexible corrugated metal gas connector must be properly installed, cannot go through the side of the furnace, and can not be used inside the furnace.

Failure to properly install metal gas connector can result in death, bodily injury and/or property damage.

Additional LP Piping Requirements

- Have a licensed LP gas dealer make all connections at storage tank and check all connections from tank to furnace.
- If copper tubing is used, it **MUST** comply with limitation set in Local Codes, or in the absence of local codes, the gas codes of the country having jurisdiction.
- Two-stage regulation of LP gas is recommended.

Final Check

- Test all pipe for leaks.
- If orifices were changed, make sure they are checked for leaks.
- During pressure testing of gas piping system, observe the following:
 - a. If test pressure does not exceed 1/2" PSIG, isolate the furnace by closing its individual manual shutoff valve.
 - b. If test pressure exceeds 1/2" PSIG, the furnace and its individual shutoff valve must be disconnected from the gas supply system.
- To check for leaks apply soap suds or a liquid detergent to each joint. Bubbles forming indicate a leak.
- Do not use an open flame to test for gas leaks. Fire or explosion could occur.
- Correct even the smallest leak at once.

⚠ WARNING

Fire or explosion hazard.

Liquid petroleum (LP) gas is heavier than air and will settle and remain in low areas and open depressions.

Thoroughly ventilate area and dissipate gas. Do NOT use a match or open flame to test for leaks, or attempt to start up furnace before thoroughly ventilating area.

An open flame or spark can result in death, personal injury and/or property damage.

8. Electrical Wiring

⚠ WARNING

Electrical shock hazard.

Turn OFF electrical power at fuse box or service panel before making any electrical connections and ensure a proper ground connection is made before connecting line voltage.

Failure to do so can result in death, personal injury and/or property damage.

Power Supply Wiring

The furnace **MUST** be electrically wired and grounded in accordance with local codes, or in the absence of local codes, the applicable national codes.

Field wiring connections must be made inside the furnace connection box. A suitable strain relief should be used at the point the wires exit the furnace casing.

Copper conductors shall be used. Line voltage wires should be sized for the input amps stated on the rating plate. Furnace must be connected to its own separate circuit.

Thermostat

Thermostat location has an important effect on the operation of the unit. Follow instructions included with thermostat for correct mounting and wiring.

Low voltage connections to furnace must be made on terminal board to fan control. (See **Figure 13** or **Figure 14**)

If cooling is used, the **Y** from the thermostat must be connected to the control board **Y** to energize cooling blower speed.*

Set thermostat heat anticipator in accordance with the *Technical Support Manual*.

Optional Equipment

All wiring from furnace to optional equipment **MUST** conform to local codes or, in the absence of local codes, the applicable national codes. Install wiring in accordance with manufacturer's instructions.

Humidifier/Electronic Air Cleaner

The furnace is wired for humidifier and/or electronic air cleaner connection.

CAUTION

Do NOT exceed 115V/0.8 amp. maximum current load for both the EAC terminal and the HUM terminal combined.

NOTE: The humidifier will be powered when the furnace is fired and the circulating air blower comes on. The electronic air cleaner will be powered anytime the thermostat calls for air movement. However, the electronic air cleaner is **NOT** energized during continuous fan operation controlled by the electronic fan control.

Figure 13

Electrical Connections
(Upflow/Horizontal)

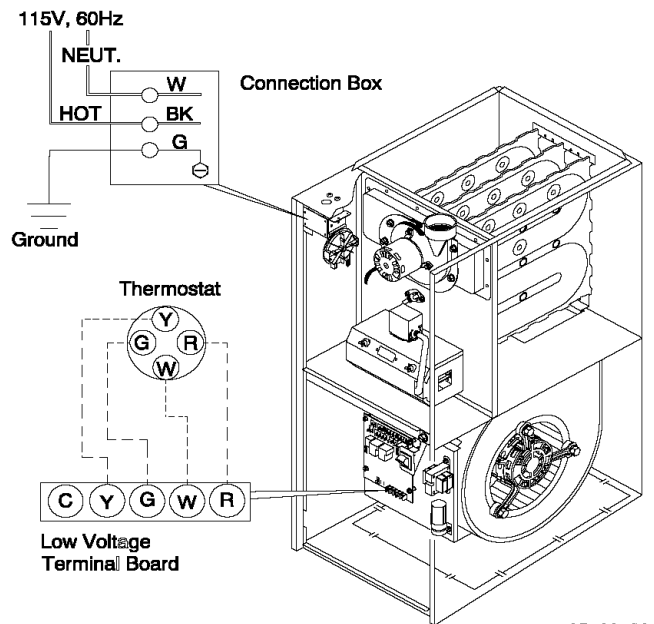

25-22-30

Figure 14

Electrical Connections
(Downflow)

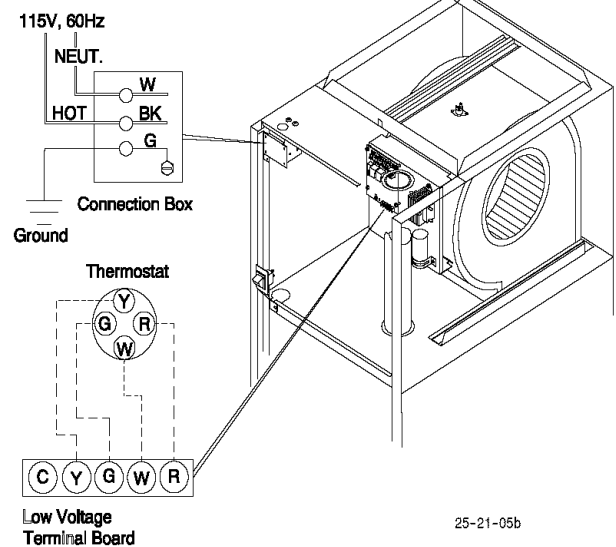

25-21-05b

Control Center Fuse

The 24V circuit contains a 5-amp, automotive-type fuse located on control center. (See **Figure 15**) Any electrical shorts of 24V wiring during installation, service, or maintenance may cause fuse to blow. If fuse replacement is required, use only a fuse of identical size (5 amp.)

Figure 15

Fan Timer Connections

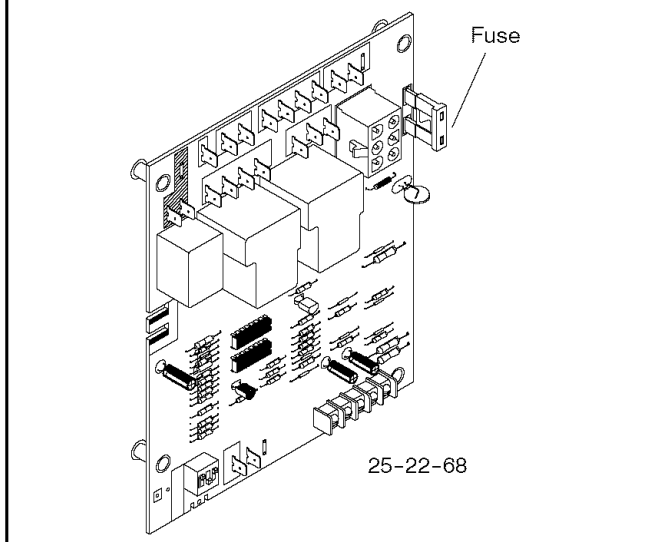

9. Ductwork and Filter (Upflow/Horizontal)

⚠ WARNING

Poison carbon monoxide gas hazard.

Do NOT draw return air from inside a closet or utility room where furnace is located. Return air duct MUST be sealed to furnace casing.

Failure to properly seal duct can result in death and/or personal injury.

When the furnace is located in an area near or adjacent to the living area, the system should be carefully designed with returns to minimize noise transmission through the return air grille. Any blower moving a high volume of air will produce audible noise which could be objectionable when the unit is located very close to a living area. It is often advisable to route the return air ducts under the floor or through the attic.

- Refer to furnace **Technical Support Manual** (Blower Data) for air flow information.
- Size ductwork to handle air flow for heating and air conditioning if used.

Duct Connections

This furnace may be installed in only a bottom or side return application. Return air through the back of the unit is **NOT** allowed.

Side connections can be made by cutting out the embossed area shown in **Figure 16**.

Duct Installation Requirements

- When furnace supply ducts carry air outside furnace area, seal return air duct to furnace casing and terminate duct outside furnace space.
- When a refrigeration coil is used in conjunction with this unit, it must be installed on the discharge side of the unit to avoid condensation on the heat exchanger.
- If separate evaporator and blower unit is used, install good sealing dampers for air flow control. Chilled air going through the furnace could cause condensation and shorten furnace life. Dampers (purchased locally) can be either automatic or manual. Manually operated dampers **MUST** be equipped with a means to prevent furnace or air conditioning operation unless damper is in the full heat or cool position.

Figure 16

Cutting Side Return Air Opening

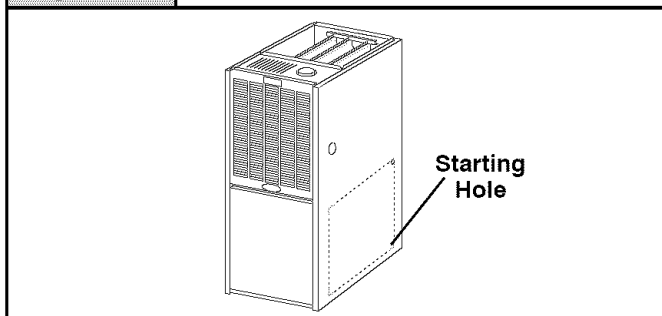

Bottom returns can be made by removing the knockout panel in the furnace base. Do **NOT** remove knock-out except for a bottom return.

Duct Design

Design and install air distribution system to comply with Air Conditioning Contractors of America manuals or other approved methods that conform to local codes and good trade practices.

⚠ WARNING

Poison carbon monoxide gas hazard.

Cool air passing over heat exchanger can cause condensate to form resulting in heat exchanger failure.

This could result in personal injury and/or death.

- Installation of locking-type dampers are recommended in all branches, or in individual ducts to balance system's air flow.
- If air return grille is located close to the fan inlet, install at least one, 90° air turn between fan and inlet grille to reduce noise.

- Ductwork installed in attic, or exposed to outside temperatures requires a minimum of 2" of insulation with outdoor type vapor barrier.
- Ductwork installed in an indoor unconditioned space requires a minimum of 1" of insulation with indoor type vapor barrier.

Filters

A filter **MUST** be used:

Filters are not supplied with these furnaces, but can be purchased from your dealer.

Use either filter type:

- Washable, high velocity filters are based on a maximum air flow rating of 600 FPM.
- Disposable, low velocity filters are based on a maximum air flow of 300 FPM when used with filter grille.
- The furnaces, with 1600 or less CFM rating use a 16" x 25" high velocity filter. On these models the filter may be mounted internally for bottom return using factory kit or externally for side return.
- The furnaces with greater than 1600 CFM requires that both left and right side returns are used in side return applications. Two 16" x 25" high velocity filters and racks are provided with furnace. Filter racks must be mounted externally. If return air must be on one side only, an optional 20" x 25" filter standoff rack kits can be used. (See **Figure 17**) For bottom return, an optional 20" x 25" filter rack kit can be mounted internally.

NOTE: The 20 x 25" standoff filter rack gives more filter area but does not provide more air. To achieve 2000 CFM a bottom return or 2 side returns are still needed.

NOTE: Disposable, low velocity filters may be replaced with washable, high velocity filter providing they meet the minimum size areas. Washable, high velocity filters can be replaced **ONLY** with same type and size.

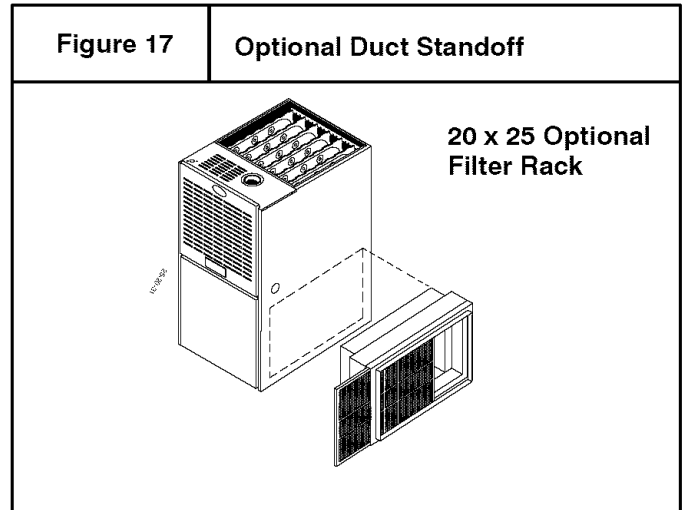

10. Ductwork and Filter (Downflow)

⚠ WARNING

Fire or explosion hazard.

Use sub-base for downflow installation on combustible floors.

Failure to use sub-base on combustible floors can result in death, bodily injury and/or property damage.

Sub-Bases for Combustible Floors - Furnace Only

The Subbase for Combustible Floors **MUST** be used when a downflow furnace is set on combustible material even when the furnace is installed on a coil box (cased coil).

NOTE: Supply opening is 3⁷/₈" from the rear of the furnace. Therefore maintain a 3⁷/₈" clearance from a wall behind the furnace (where applicable).

1. Cut the opening in the floor according to **Table 6**. The hole in the floor must be cut to the dimensions listed in **Table 6** since the base is equipped with locating tabs that center the base over the opening.

The opening in the base is 1¹/₄" shorter and 1¹/₈" narrower than the minimum required size of the opening in the floor. This is done to maintain a 1" clearance between the floor and the plenum.

2. Fabricate the plenum to the dimensions given in **Table 6**. Note that the dimensions given are outside dimensions.

Table 6		Sub-bases for Combustible Floors Dimensions									
sub-base for Combustible Floors Part Number	sub-base for Combustible Floor Dimensions				Opening In Floor		Opening In Base For Plenum		Typical Plenum Dimensions		
	H*	J*	K**	L	M	N	P	R	S	T	
(Furnace Only)											
NAHH001SB	15 ¹¹ / ₁₆	28 ³ / ₄	14 ⁹ / ₁₆	16	16 ¹ / ₄	14 ⁵ / ₈	15	13 ¹ / ₂	15	13 ¹ / ₂	
NAHH002SB	19 ⁵ / ₁₆	28 ³ / ₄	18 ³ / ₁₆	16	16 ¹ / ₄	18 ¹ / ₄	15	17 ¹ / ₈	15	17 ¹ / ₈	
NAHH003SB	22 ¹⁵ / ₁₆	28 ³ / ₄	21 ¹³ / ₁₆	16	16 ¹ / ₄	21 ⁷ / ₈	15	19 ³ / ₄	15	19 ³ / ₄	
sub-base for Cased Coil											
NAHH004SB	15 ¹¹ / ₁₆	20 ⁹ / ₁₆	14 ⁹ / ₁₆	16	16 ¹ / ₄	14 ⁵ / ₈	15	13 ¹ / ₂	15	13 ¹ / ₂	
NAHH005SB	19 ⁵ / ₁₆	20 ⁹ / ₁₆	18 ³ / ₁₆	16	16 ¹ / ₄	18 ¹ / ₄	15	17 ¹ / ₈	15	17 ¹ / ₈	
NAHH006SB	22 ¹⁵ / ₁₆	20 ⁹ / ₁₆	21 ¹³ / ₁₆	16	16 ¹ / ₄	21 ⁷ / ₈	15	19 ³ / ₄	15	19 ³ / ₄	
* Outside Dimension											
** Base Spacer Side To Side											

- Set the base over the opening in the floor, centering the opening in the base over the opening in the floor. Fasten the base to the floor with screws or nails. See **Figure 18** and **Figure 20**.
- Drop the plenum through the opening in the base. The flange of the plenum should rest on top of the combustible floor base.

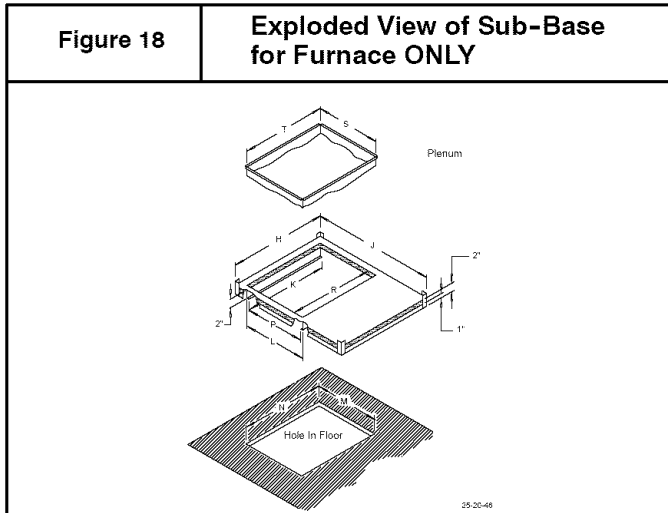

Sub-base for Combustible Floors- Downflow Coil Box

The Subbase for Combustible Floors **MUST** be used when a downflow furnace, **used with a downflow coil box**, is set on combustible flooring.

NOTE: Supply opening is $3\frac{7}{8}$ " from the rear of the furnace. Therefore maintain a $3\frac{7}{8}$ " clearance from wall (where applicable).

- Cut the opening in the floor according to **Table 6**. The hole in the floor must be cut to the dimensions listed in **Table 6** since the base is equipped with locating tabs that center the base over the opening.

The opening in the base is $1\frac{1}{4}$ " shorter and $1\frac{1}{8}$ " narrower than the recommended size of the opening in the floor. This is done to provide a 1" clearance between the floor and the plenum.

- Fabricate the plenum to the dimensions given in **Table 6**. Note that the dimensions given are outside dimensions.
- Set the base over the opening in the floor, centering the opening in the base over the opening in the floor. Fasten the base to the floor with screws or nails. See **Figure 19** and **Figure 20**.
- Drop the plenum through the opening in the base. The flange of the plenum should rest on top of the combustible floor base.

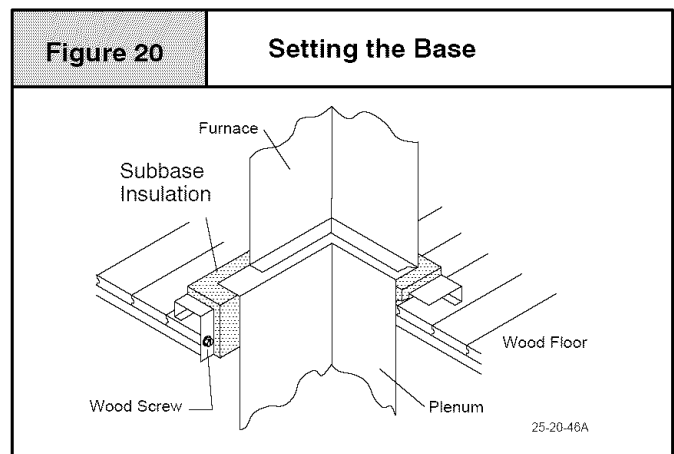
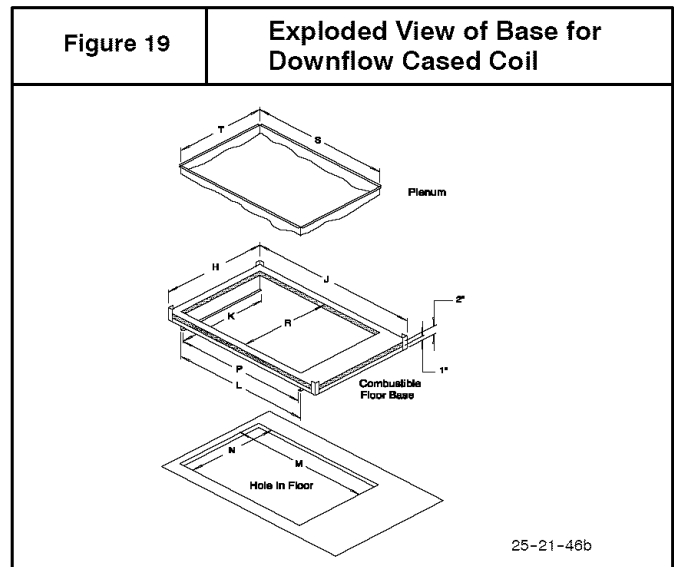

This subbase for combustible floors has been designed so that the height of the sub-base raises the downflow coil off the floor to allow easy installation of the condensate drain. See **Figure 21**.

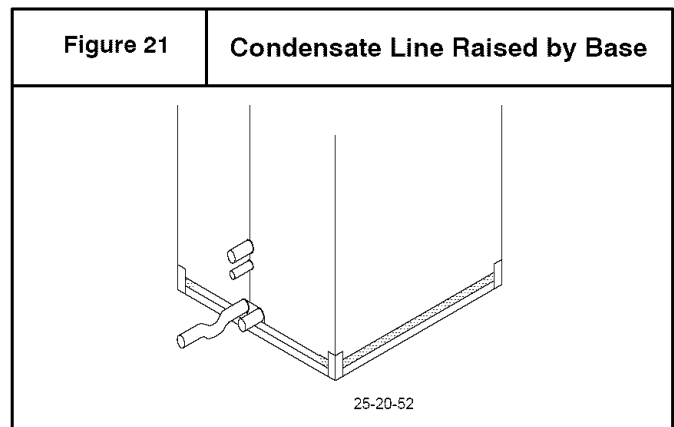

Filters:

The filter may be installed in the return air plenum above the furnace. A filter rack is supplied with each furnace. See **Figure 22** or **Figure 23**.

NOTE: The return air plenum **MUST** extend a sufficient height above dimensions "A" (**Figure 23**) to provide for the attachment of a return air duct or grille above the filters.

- Insert end of filter rack with $\frac{3}{4}$ " (19mm) flange into slot in the back of the unit. See **Figure 22**.

- With filter rack pushed back, insert front end with $\frac{1}{4}$ " flange into position and push into front slot. With filter rack pushed as far forward as it will go, bend $\frac{1}{4}$ " flange and $\frac{3}{4}$ " flange up 90° . See **Figure 22**.

NOTE: Plenum must be fitted as close to the return air flange of the unit as possible to eliminate any air bypassing the filters.

NOTE: If filters are installed in the plenum with the filter rack provided use two 16" x 18" high velocity filters. Otherwise consult filter section of the "User's Information Manual" for proper size.

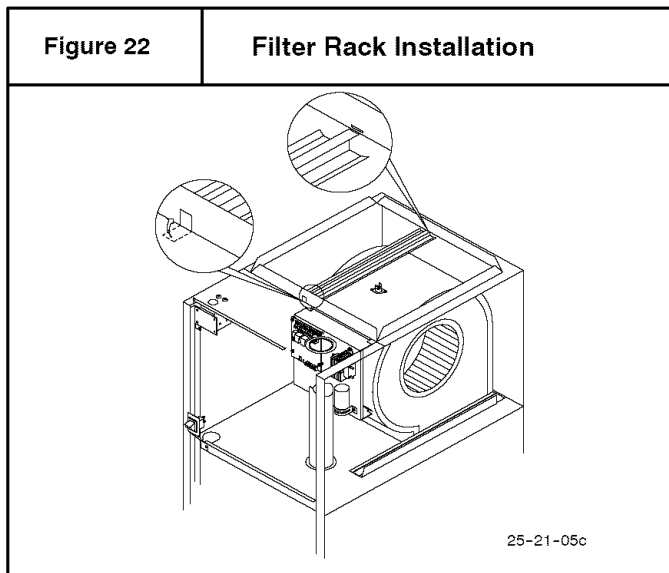

- Filters can only be installed through the right hand side of the unit blower opening. Slide filter into unit until it is in position to be pushed up and over into place on the left hand side of unit. See **Figure 23**.
- Slide remaining filter into unit and up into place on left hand side of unit. See **Figure 23**.

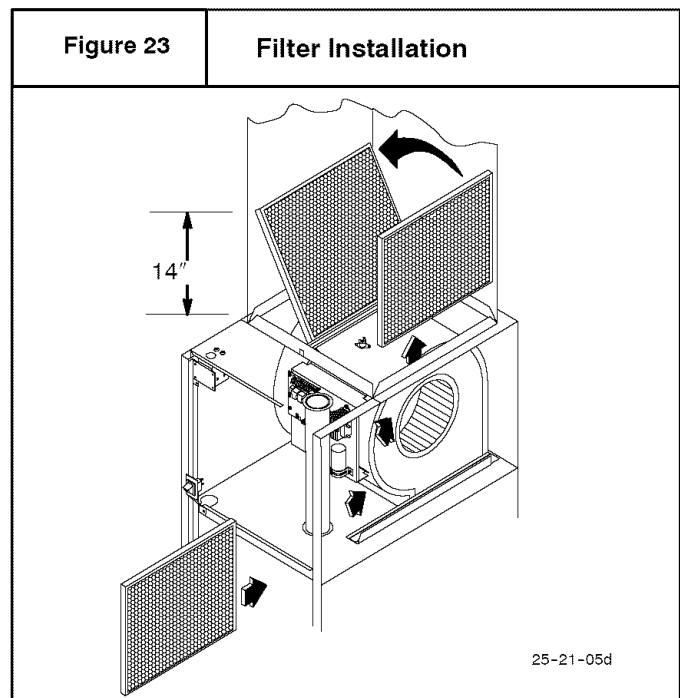

If there is insufficient plenum height for this type of installation, filters may be installed in any accessible location in the return air system. In such a case, the filters should be of adequate size and style as originally supplied with the furnace.

Filter Removal

- Remove compartment door.
- Reach up above right side of blower and lift dirty filters out of rack at top of furnace.
- Straighten up filters and pull straight down at side of blower. Pull out through right door opening.
- Vacuum clean or wash with warm water and dry thoroughly before replacing.

11. Checks and Adjustments

Startup

NOTE: Refer to startup procedures in the *Users Information Manual*.

CAUTION

If any sparks, odors or unusual noises occur, immediately shut OFF power to furnace. Check for wiring errors or obstruction to blower.

Gas Supply Pressure

Gas supply pressure should be within minimum and maximum values listed on rating plate. Pressures are usually set by gas suppliers.

(See L.P. Kit instruction manual for furnaces converted to L.P. gas)

Manifold Gas Pressure Adjustment

NOTE: Make adjustment to manifold pressure with burners operating.

	<h2 style="margin: 0;">WARNING</h2>
<p>Fire or explosion hazard.</p> <p>Turn OFF gas at shut off before connecting manometer.</p> <p>Failure to turn OFF gas at shut off before connecting manometer can result in death and/or personal injury.</p>	

- With gas OFF, Connect manometer to gas valve or manifold tap. Use manometer with a 0 to min. 12" water column range.
- Turn gas ON and remove adjustment screw cover on gas valve. Turn counterclockwise to decrease pressure and clockwise to increase.

NOTE: Adjustment screw cover **MUST** be placed on gas valve before reading manifold pressure and operating furnace.

- For altitudes up to 2000', set pressure to value shown in **Table 2**. For altitudes between 2000' to 8000', see Section 7. "Gas Supply and Piping" for correct pressure value.

Adjust Pilot Burner

The furnace has a pilot flame to light the main burner. The flame should surround $\frac{3}{8}$ " to $\frac{1}{2}$ " of the flame rod. See **Figure 24**. To adjust, remove cap from pilot adjusting screw on gas valve. Turn screw counterclockwise to increase or clockwise to decrease flame as required. Replace cap after adjusting screw.

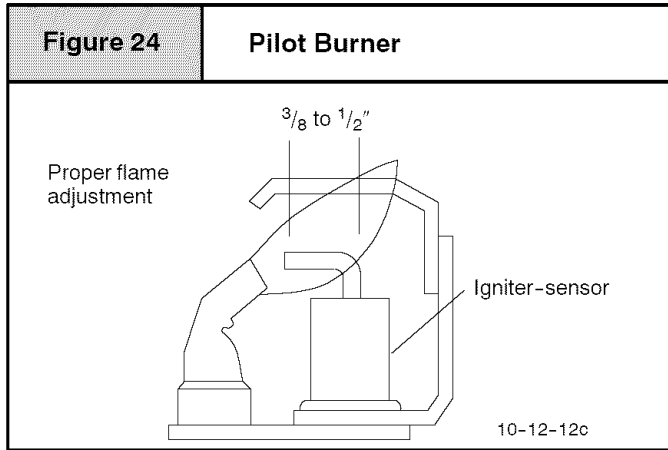

Main Burner Flame Check

Allow the furnace to run approximately 10 minutes then inspect the main burner and pilot flames. See **Figure 25**.

Check for the following (**Figure 25**):

- Stable and blue flames. Dust may cause orange tips or wisps of yellow, but flames **MUST NOT** have solid, yellow tips.
- Flames extending directly from burner into heat exchanger.
- Flames do **NOT** touch sides of heat exchanger

If any problems with main burner flames are noted, it may be necessary to adjust gas pressures, or check for drafts.

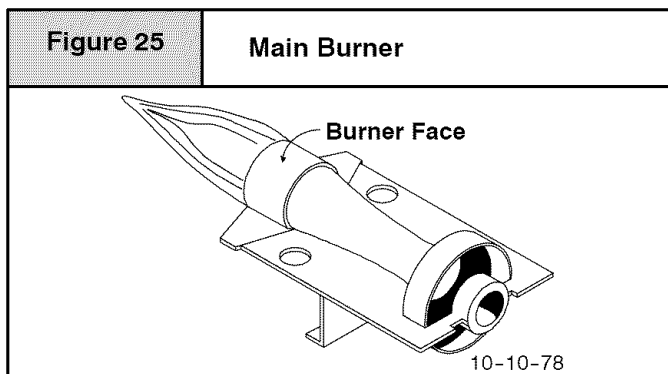

Temperature Rise Check

The blower speed **MUST** be set to give the correct air temperature rise through the furnace as marked on the rating plate. Temperature rise is the difference between supply and return air temperatures.

Changing Blower Speed

⚠ WARNING

Electrical shock hazard.

Turn OFF power to furnace before changing speed taps.

Failure to do so can result in death, personal injury and/or property damage.

NOTE: The speed taps that the manufacture sets from the factory for this product are based on a nominal 400 CFM per ton cooling and the basic mid range on the temperature rise for heating.

Since the manufacturer cannot establish the static pressure that will be applied to the unit, it is the responsibility of the installer dealer/contractor to select the proper speed taps for the application when the unit is installed.

If it is necessary to change speeds, refer to steps below.

1. Refer to *Furnace Wiring Diagram* for location of the heating and cooling speed taps located on the electronic fan control as well as location of unused blower motor speed leads. Use the chart (**Table 7**) to determine the blower motor speed settings.

Wire Color	Motor Speed
Black	High
Orange*	Med-High
Blue	Medium
Red	Low

* Med-High speed may not be provided on all models.

2. Change the heat or cool blower motor speed by removing the motor lead from the "**Heat**" or "**Cool**" terminal and replace it with the desired motor speed lead from the "**Unused Motor Lead**" location. Connect the wire previously removed from the "**Heat**" or "**Cool**" terminal to the vacated "**Unused Motor Lead**" terminal.
3. If the same speed must be used for both heating and cooling, remove the undesired motor speed lead from the "**Heat**" or "**Cool**" terminal and connect that lead to the open terminal at "**Unused Motor Lead**" location or tape off. Attach a jumper between the "**Heat**" and "**Cool**" terminals and the remaining motor speed lead.

Note: When using the same speed on motors with (4) speed leads, it will be necessary to tape off the terminal of the motor speed lead removed from the "**Heat**" or "**Cool**" terminal with electrical tape since an open terminal will not be available at the "**Unused Motor Lead**" location.

Continuous Fan Operation

A terminal is provided on the electronic fan control located in the circulating blower compartment for operation of the continuous fan option. This connection is intended for the low speed motor tap, and has a lower contact rating (8 amps) than the heat and cool taps. When the low speed blower lead is connected to this terminal, this will provide low speed blower operation whenever the other two speeds (**Heat** or **Cool**) are not energized.

Thoroughly check the system after modification to ensure the proper operation of the circulating air blower in all modes of operation.

Separate speed selections for Heat, Cool, and Continuous Fan

Connect low speed lead from circulating motor to the “**Cont**” terminal at the electronic fan control. The appropriate motor leads should already be connected to the “**Heat**” and “**Cool**” terminals.

Heating and Continuous Blower Speed the Same

If it is necessary to operate the heating speed and continuous

blower speed using the same blower speed, connect a jumper between the “**Heat**” and “**Cont**” terminals on the electronic fan control.

Note: There should be only **ONE** motor lead going to the “**Heat**” and “**Cont**” terminals.

12. Furnace Maintenance

CAUTION

It is recommended that the furnace be inspected and serviced on an annual basis (before the heating season) by a qualified service technician.

See “*User’s Information Manual*”.

Technical Support Manual

Save This Manual For Future Reference

Models

NTC6050FBG1	GNE050B12G1
NTC6075FBG1	GNE075B12G1
NTC6075HFG1	GNE075F16G1
NTC6100GFG1	GNE100F14G1
NTC6100KFG1	GNE100F20G1
NTC6100KJG1	GNE100J20G1
NTC6125KJG1	GNE125J20G1
NTC6150KJG1	GNE150J20G1
NTN6050FBG1	NNE050B12G1
NTN6075FBG1	NNE075B12G1
NTN6075HFG1	NNE075F16G1
NTN6100KFG1	NNE100F20G1
NTN6100KJG1	NNE100J20G1
NTN6125KJG1	NNE125J20G1
NDN6050FBG1	GDE050B12G1
NDN6075FBG1	GDE075B12G1
NDN6075HFG1	GDE075F16G1
NDN6100GFG1	GDE100F14G1
NDN6100KFG1	GDE100F20G1
NDN6125KJG1	GDE125J20G1

Models

NTN3050FBG1	NBF050B12G1
NTN3075FBG1	NBF075B12G1
NTN3075HFG1	NBF075F16G1
NTN3100KFG1	NBF100F20G1
NTN3100KJG1	NBF100J20G1
NTN3100LJG1	NBF100J22G1
NTN3125KJG1	NBF125J20G1
NTN3125LJG1	NBF125J22G1
NTG3050FBG1	FBF050B12G1
NTG3075FBG1	FBF075B12G1
NTG3075HFG1	FBF075F16G1
NTG3100GFG1	FBF100F14G1
NTG3100KFG1	FBF100F20G1
NTG3100LJG1	FBF100J22G1
NTG3125KJG1	FBF125J20G1
NTG3125LJG1	FBF125J22G1
NDN3050FBG1	NDF050B12G1
NDN3075FBG1	NDF075B12G1
NDN3075HFG1	NDF075F16G1
NDN3100GFG1	NDF100F14G1
NDN3100KFG1	NDF100F20G1
NDN3125KJG1	NDF125J20G1

Manufactured by:

International Comfort Products Corporation (USA)

Lewisburg, TN USA 37091



FAN ASSISTED COMBUSTION GAS FURNACES

Manufacturers Number (Mfr No -See Rating Plate)

ALL Models

Specifications

	NTN3050FB/ NBF050B12 NTG3050FB /FBF050B12		NTN3075FB/ NBF075B12 NTG3075FB /FBF075B12		NTN3075HF/ NBF075F16 NTG3075HF /FBF075F16		NTN3100KF/ NBF100F20		NTN3100KJ/ NBF100J20 NTG3100KF /FBF100F20		NTN3100LJ/ NBF100J22 NTG3100LJ/ FBF100J22		NTN3125KJ/ NBF125J20 NTG3125KJ/ FBF125J20		NTN3125LJ/ NBF125J22 NTG3125LJ/ FBF125J22	
General																
Input (Btuh)	50,000		75,000		75,000		100,000		100,000		100,000		125,000		125,000	
Output (Btuh)	40,000		59,000		59,000		79,000		79,000		79,000		99,000		99,000	
Temp. Rise (°F)	35-65		35-65		25-55		35-65		35-65		40-70		40-70		40-70	
Electrical (Volts/Hz/FLA)	115/60/5.3		115/60/5.3		115/60/12.0		115/60/12.0		115/60/12.0		115/60/12.0		115/60/12.0		115/60/12.0	
Gas Type	Nat	LP	Nat	LP	Nat	LP	Nat	LP	Nat	LP	Nat	LP	Nat	LP	Nat	LP
Transformer Size (VA)	40	40	40	40	40	40	40	40	40	40	40	40	40	40	40	40
T'stat Heat Anticipator	.30	.30	.30	.30	.30	.30	.30	.30	.30	.30	.30	.30	.30	.30	.30	.30
Gas & Ignition																
Std. Main Orifices (No/Size)	2/#42	2/#54	3/#42	3/#54	3/#42	3/#54	4/#42	4/#54	4/#42	4/#54	4/#42	4/#54	5/#42	5/#54	5/#42	5/#54
Gas Valve Honeywell VR	8204	8204	8204	8204	8204	8204	8204	8204	8204	8204	8204	8204	8204	8204	8204	8204
Regulation Type	SNAP	SNAP	SNAP	SNAP	SNAP	SNAP	SNAP	SNAP	SNAP	SNAP	SNAP	SNAP	SNAP	SNAP	SNAP	SNAP
Manifold Press. (Inch's WC)	3.5	10.0	3.5	10.0	3.5	10.0	3.5	10.0	3.5	10.0	3.5	10.0	3.5	10.0	3.5	10.0
Pilot Orifice Size	.018	.011	.018	.011	.018	.011	.018	.011	.018	.011	.018	.011	.018	.011	.018	.011
Ignition Type/Series	HW S8600		HW S8600		HW S8600		HW S8600		HW S8600		HW S8600		HW S8600		HW S8600	
Lock-Out Time	NA		NA		NA		NA		NA		NA		NA		NA	
Combustion																
Flue Outlet Size (Inches)	3		3		3		3		3		3		3		3	
Std. Outlet Temp (°F)	<480		<480		<480		<480		<480		<480		<480		<480	
Limits & Controls																
Thermal Sensor (°F)	300		300		300		300		300		300		300		300	
Limit Control Setting (°F)	See Parts List		See Parts List		See Parts List		See Parts List		See Parts List		See Parts List		See Parts List		See Parts List	
Auxiliary Limit (°F)	130		130		130		130		130		130		130		130	
Std. Pressure Sw. (Part No)	1010898		1010898		1010898		1010898		1010898		1010898		1010898		1010898	
Press (Close)	-0.81		-0.81		-0.81		-0.81		-0.81		-0.81		-0.81		-0.81	
Press (Open)	-0.65		-0.65		-0.65		-0.65		-0.65		-0.65		-0.65		-0.65	
Fan Control (Type)	HW ST9120		HW ST9120		HW ST9120		HW ST9120		HW ST9120		HW ST9120		HW ST9120		HW ST9120	
Fan Control On	30/60		30/60		30/60		30/60		30/60		30/60		30/60		30/60	
Fan Control Off	60,100,140,180		60,100,140,180		60,100,140,180		60,100,140,180		60,100,140,180		60,100,140,180		60,100,140,180		60,100,140,180	
Blower Data																
Type & Size	10-8		10-8		10-10		10-10		11-10		11-10		11-10		11-10	
Motor Amps/Rpm	6.5/1050		6.5/1050		10.3/1100		11.9/900		11.9/900		11.9/900		11.9/900		11.9/900	
Motor Type/H.p.	PSC ¹ / ₃		PSC ¹ / ₃		PSC ¹ / ₂		PSC ³ / ₄		PSC ³ / ₄		PSC ³ / ₄		PSC ³ / ₄		PSC ³ / ₄	
Cap. Mfd/Volts	5/370		5/370		10/370		10/370		10/370		10/370		10/370		10/370	
Filter Type	Washable		Washable		Washable		Washable		Washable		Washable		Washable		Washable	
Filter Size (")	14x25x1		14x25x1		16x25x1		16x25x1		16x25x1		16x25x1		16x25x1 (2)		16x25x1	
Min. Cool Cap. (Tons)	1.5		1.5		3		3		3		3		3		3	
Max. Cool Cap. (Tons)	3		3		4		5		5		5		5		5	

Gas Conversion Kits

Nat to LP NAHF002LP or NAHL002LP, *1160991

LP to Nat NAHF002NG, *1009510*

LP High Altitude *1160992

*Must be ordered from Service Parts

Manufacturers Number (Mfr No -See Rating Plate)
ALL Models
Specifications

	NDN3050FB/ NDF050B12		NDN3075FB/ NDF075B12		NDN3075HF/ NDF075F16		NDN3100GF/ NDF100F14		NDN3100KF/ NDF100F20		NDN3125KJ/ NDF125J20	
General												
Input (Btuh)	50,000		75,000		75,000		100,000		100,000		125,000	
Output (Btuh)	40,000		61,000		61,000		81,000		81,000		102,000	
Temp. Rise (°F)	30-60		40-70		40-70		40-70		40-70		45-75	
Electrical (Volts/Hz/FLA)	115/60/5.3		115/60/5.3		115/60/12.0		115/60/7.5		115/60/12.0		115/60/12.0	
Gas Type	Nat	LP	Nat	LP	Nat	LP	Nat	LP	Nat	LP	Nat	LP
Transformer Size (VA)	40	40	40	40	40	40	40	40	40	40	40	40
T'stat Heat Anticipator	.30	.30	.30	.30	.30	.30	.30	.30	.30	.30	.30	.30
Gas & Ignition												
Std. Main Orifices (No/Size)	2/#42	2/#54	3/#42	3/#54	3/#42	3/#54	4/#42	4/#54	4/#42	4/#54	5/#42	5/#54
Gas Valve Honeywell	SV9501	SV9501	SV 9501	SV9501	SV 9501	SV9501	SV 9501	SV9501	SV 9501	SV9501	SV 9501	SV9501
Regulation Type	SNAP	SNAP	SNAP	SNAP	SNAP	SNAP	SNAP	SNAP	SNAP	SNAP	SNAP	SNAP
Manifold Press. (Inch's WC)	3.5	10.0	3.5	10.0	3.5	10.0	3.5	10.0	3.5	10.0	3.5	10.0
Pilot Orifice Size	.018	.011	.018	.011	.018	.011	.018	.011	.018	.011	.018	.011
Ignition Type/Series	HW HSP		HW HSP		HW HSP		HW HSP		HW HSP		HW HSP	
Lock-Out Time	NA		NA		NA		NA		NA		NA	
Limits & Controls												
Thermal Sensor (°F)	300		300		300		300		300		300	
Limit Control Setting (°F)	See Parts List		See Parts List		See Parts List		See Parts List		See Parts List		See Parts List	
Auxiliary Limit (°F)	110		110		110		110		110		110	
Std. Pressure Sw. (Part No)	1010898		1010898		1010898		1010898		1010898		1010898	
Press (Close)	-0.75		-0.75		-0.75		-0.75		-0.75		-0.75	
Press (Open)	-0.65		-0.65		-0.65		-0.65		-0.65		-0.65	
Fan Control (Type)	HW ST9120		HW ST9120		HW ST9120		HW ST9120		HW ST9120		HW ST9120	
Fan Control On	30/60		30/60		30/60		30/60		30/60		30/60	
(Timed-secs) Off	60,100,140,180		60,100,140,180		60,100,140,180		60,100,140,180		60,100,140,180		60,100,140,180	
Combustion												
Flue Outlet Size (Inches)	3		3		3		3		3		3	
Std. Outlet Temp (°F)	<480		<480		<480		<480		<480		<480	
Blower Data												
Type & Size	10-8		10-8		11-10		11-10		11-10		11-10	
Motor Amps/Rpm	6.5/1050		6.5/1050		10.3/1100		8/1050		10.3/1100		11.9/900	
Motor Type/H.p.	PSC/1/3		PSC/1/3		PSC/1/3		PSC/1/2		PSC/1/2		PSC/3/4	
Cap. Mfd/Volts	5/370		5/370		5/370		5/370		5/370		5/370	
Filter Type	Washable		Washable		Washable		Washable		Washable		Washable	
Filter Size (")	16x18x1 (2)		16x18x1 (2)		16x18x1 (2)		16x18x1 (2)		16x18x1 (2)		16x18x1 (2)	
Min. Cool Cap. (Tons)	1.5		1.5		3		2		3		3	
Max. Cool Cap. (Tons)	3		3		4		3.5		5		5	

Gas Conversion Kits

Nat to LP NAHF002LP or NAHL002LP, *1160991

LP to Nat NAHF002NG, *1009510*

LP High Altitude *1160992

*Must be ordered from Service Parts

Manufacturers Number (Mfr No -See Rating Plate)

ALL Models

Specifications

	NTC6050FB/ GNE050B12 NTN6050FB/ NNE050B12		NTC6075FB/ GNE075B12 NTN6075FB/ NNE075B12		NTC6075HF/ GNE075F16 NTN6075HF/ NNE075F16		NTC6100GF/ GNE100F14		NTC6100KF/ GNE100F20 NTN6100KF/ NNE100F20		NTC6100KJ/ GNE100J20 NTN6100KJ/ NNE100J20		NTC6125KJ/ GNE125J20 NTN6125KJ/ NNE125J20	
General														
Input (Btuh)	50,000		75,000		75,000		100,000		100,000		100,000		125,000	
Output (Btuh)	40,000		59,000		59,000		79,000		79,000		79,000		99,000	
Temp. Rise (°F)	35-65		35-65		25-55		45-75		35-65		35-65		40-70	
Electrical (Volts/Hz/FLA)	115/60/5.3		115/60/5.3		115/60/12.0		115/60/7.5		115/60/12.0		115/60/12.0		115/60/12.0	
Gas Type	Nat	LP	Nat	LP	Nat	LP	Nat	LP	Nat	LP	Nat	LP	Nat	LP
Transformer Size (VA)	40		40		40		40		40		40		40	
T'stat Heat Anticipator	.30		.30		.30		.30		.30		.30		.30	
Gas & Ignition														
Gas Type	Nat	LP	Nat	LP	Nat	LP	Nat	LP	Nat	LP	Nat	LP	Nat	LP
Std. Main Orifices (No/Size)	2/#42	2/#54	3/#42	3/#54	3/#42	3/#54	4/#42	4/#54	4/#42	4/#54	4/#42	4/#54	5/#42	5/#54
Gas Valve Honeywell SV	9501	9501	9501	9501	9501	9501	9501	9501	9501	9501	9501	9501	9501	9501
Regulation Type	SNAP	SNAP	SNAP	SNAP	SNAP	SNAP	SNAP	SNAP	SNAP	SNAP	SNAP	SNAP	SNAP	SNAP
Manifold Press. (Inch's WC)	3.5	10.0	3.5	10.0	3.5	10.0	3.5	10.0	3.5	10.0	3.5	10.0	3.5	10.0
Pilot Orifice Size	.018	.011	.018	.011	.018	.011	.018	.011	.018	.011	.018	.011	.018	.011
Ignition Type/Series Honeywell	HSP		HSP		HSP		HSP		HSP		HSP		HSP	
Lock-Out Time	NA		NA		NA		NA		NA		NA		NA	
Combustion														
Flue Outlet Size (Inches)	3		3		3		3		3		3		3	
Std. Outlet Temp (°F)	<480		<480		<480		<480		<480		<480		<480	
Limits & Controls														
Thermal Sensor (°F)	300		300		300		300		300		300		300	
Limit Control Setting (°F)	See Parts List		See Parts List		See Parts List		See Parts List		See Parts List		See Parts List		See Parts List	
Auxiliary Limit (°F)	130		130		130		130		130		130		130	
Std. Pressure Sw. (Part No)	1010897		1010897		1010897		1010896		1010896		1010896		1010898	
Press (Close)	-0.50		-0.50		-0.50		-0.60		-0.60		-0.60		-0.75	
Press (Open)	-0.40		-0.40		-0.40		-0.50		-0.50		-0.50		-0.65	
Fan Control (Type)	HW ST9120				HW ST9120				HW ST9120				HW ST9120	
Fan Control On	30/60				30/60				30/60				30/60	
(Timed-secs) Off	60,100,140,180				60,100,140,180				60,100,140,180				60,100,140,180	
Blower Data														
Type & Size	10-8		10-8		10-10		10-10		11-10		11-10		11-10	
Motor Amps/Rpm	6.5/1050		6.5/1050		10.3/1100		8.0/1050		10.6/1100		11.9/900		11.9/900	
Motor Type/H.p.	PSC/1/3		PSC/1/3		PSC/1/2		PSC/1/2		PSC/3/4		PSC/3/4		PSC/3/4	
Cap. Mfd/Volts	5/370		5/370		10/370		7.5/370		10/370		10/370		10/370	
Filter Type	Washable		Washable		Washable		Washable		Washable		Washable		Washable	
Filter Size (")	14x25x1		14x25x1		16x25x1		16x25x1		16x25x1		16x25x1		16x25x1 (2)	
Min. Cool Cap. (Tons)	1.5		1.5		3		1.5		3		3		3	
Max. Cool Cap. (Tons)	3		3		4		3.5		4.5		5		5	
Gas Conversion Kits														
Nat to LPNAHF002LP *1009509 or NAHL002LP *1160991														
LP to Nat *1009510														
LP High Altitude *1160992														
Nat High Altitude *1160993														
*Must be ordered from Service Parts														

Manufacturers Number (Mfr No -See Rating Plate)

ALL Models

Specifications

	NTC6150KJ/ GNE150J20		NDN6050FB/ GDE050B12		NDN6075FB/ GDE075B12		NDN6075HF/ GDE075F16		NDN6100GF/ GDE100F14		NDN6100KF/ GDE100F20		NDN6125KJ/ GDE125J20	
General														
Input (Btuh)	150,000		50,000		75,000		75,000		100,000		100,000		125,000	
Output (Btuh)	120,000		40,000		61,000		61,000		81,000		81,000		102,000	
Temp. Rise (°F)	45-75		30-60		40-70		40-70		40-70		40-70		45-75	
Electrical (Volts/Hz/FLA)	115/60/12.0		115/60/5.3		115/60/5.3		115/60/12.0		115/60/7.5		115/60/12.0		115/60/12.0	
Gas Type	Nat	LP	Nat	LP	Nat	LP	Nat	LP	Nat	LP	Nat	LP	Nat	LP
Transformer Size (VA)	40		40		40		40		40		40		40	
T'stat Heat Anticipator	.30		.30		.30		.30		.30		.30		.30	
Gas & Ignition														
Std. Main Orifices (No/Size)	6#42	6#54	2#42	2#54	3#42	3#54	3#42	3#54	4#42	4#54	4#42	4#54	5#42	5#54
Gas Valve Honeywell SV	9501	9501	9501	9501	9501	9501	9501	9501	9501	9501	9501	9501	9501	9501
Regulation Type	SNAP	SNAP	SNAP	SNAP	SNAP	SNAP	SNAP	SNAP	SNAP	SNAP	SNAP	SNAP	SNAP	SNAP
Manifold Press. (Inch's WC)	3.5	10.0	3.5	10.0	3.5	10.0	3.5	10.0	3.5	10.0	3.5	10.0	3.5	10.0
Pilot Orifice Size	.018	.011	.018	.011	.018	.011	.018	.011	.018	.011	.018	.011	.018	.011
Ignition Type/Series Honeywell	HSP		HSP		HSP		HSP		HSP		HSP		HSP	
Lock-Out Time	NA		NA		NA		NA		NA		NA		NA	
Combustion														
Flue Outlet Size (Inches)	3		3		3		3		3		3		3	
Std. Outlet Temp (°F)	<480		<480		<480		<480		<480		<480		<480	
Limits & Controls														
Thermal Sensor (°F)	300		300		300		300		300		300		300	
Limit Control Setting (°F)	See Parts List		See Parts List		See Parts List		See Parts List		See Parts List		See Parts List		See Parts List	
Auxiliary Limit (°F)	130		110		110		110		110		110		110	
Std. Pressure Sw. (Part No)	1010898		1010897		1010896		1010896		1010898		1010898		1010898	
Press (Close)	-0.75		-0.50		-0.60		-0.60		-0.75		-0.75		-0.75	
Press (Open)	-0.65		-0.40		-0.50		-0.50		-0.65		-0.65		-0.65	
Fan Control (Type) Honeywell	ST9120		ST9120		ST9120		ST9120		ST9120		ST9120		ST9120	
Fan Control On	30/60		30/60		30/60		30/60		30/60		30/60		30/60	
(Timed-secs) Off	60,100,140,180		60,100,140,180		60,100,140,180		60,100,140,180		60,100,140,180		60,100,140,180		60,100,140,180	
Blower Data														
Type & Size	12-12		10-8		10-8		11-10		11-10		11-10		11-10	
Motor Amps/Rpm	11.9/900		6.5/1050		6.5/1050		10.3/1100		8/1050		10.3/1100		11.9/900	
Motor Type/H.p.	PSC ^β /1/4		PSC ¹ /1/3		PSC ¹ /1/3		PSC ¹ /1/3		PSC ¹ /1/2		PSC ¹ /1/2		PSC ^β /1/4	
Cap. Mfd/Volts	10/370		5/370		5/370		5/370		5/370		5/370		5/370	
Filter Type	Washable		Washable		Washable		Washable		Washable		Washable		Washable	
Filter Size (")	16x25x1 (2)		16x18x1 (2)		16x18x1 (2)		16x18x1 (2)		16x18x1 (2)		16x18x1 (2)		16x18x1 (2)	
Min. Cool Cap. (Tons)	3		1.5		1.5		3		2		3		3	
Max. Cool Cap. (Tons)	5		3		3		4		3.5		5		5	

Gas Conversion Kits

Nat to LPNAHF002LP *1009509 or NAHL002LP *1160991

LP to Nat *1009510

LP High Altitude *1160992

Nat High Altitude *1160993

*Must be ordered from Service Parts

CIRCULATION AIR BLOWER DATA

NTG3050FB/FBF050B12, NTN3050FB/NBF050B12, NTG3075FB/FBF075B12, NTN3075FB/NBF075B12 & NTC6050FB/GNE050B12, NTN6050FB/NNE050B12, NTC6075FB/GNE075B12, NTN6075FB/NNE075B12

External Static Pressure Inches of W.C.	Air Delivery in Cubic Feet per Minute (C.F.M.) (Furnace Rated @0.5" WC ESP)					
	TAP	LOW	MED L	MED	MED H	HIGH
	.10	675	859	--	1015	1394
	.20	662	468	--	999	1342
	.30	651	819	--	977	1289
	.40	636	795	--	952	1227
	.50	608	765	--	914	1163
	.60	564	735	--	870	1086
.70	514	685	--	818	1002	

External Static Pressure Inches of W.C.	Air Delivery in Liters Per Second (L/S) (Furnace Rated @0.5" WC ESP)					
	TAP	LOW	MED L	MED	MED H	HIGH
	.10	318	405	--	479	658
	.20	312	399	--	472	633
	.30	307	387	--	461	608
	.40	300	375	--	449	579
	.50	287	361	--	431	549
	.60	266	347	--	411	513
.70	243	323	--	386	473	

NTN3075HFA/NBF075F16A & NTG3075HFA/FBF075F16A, NTC6075HF/GNE075F16 & NTN6075HF/NNE075F16

External Static Pressure Inches of W.C.	Air Delivery in Cubic Feet per Minute (C.F.M.) (Furnace Rated @0.5" WC ESP)					
	TAP	LOW	MED L	MED	MED H	HIGH
	.10	1503	1722	--	--	1887
	.20	1460	1660	--	--	1810
	.30	1420	1608	--	--	1752
	.40	1370	1540	--	--	1670
	.50	1318	1484	--	--	1599
	.60	1250	1400	--	--	1520
.70	1182	1322	--	--	1425	

External Static Pressure Inches of W.C.	Air Delivery in Liters Per Second (L/S) (Furnace Rated @0.5" WC ESP)					
	TAP	LOW	MED L	MED	MED H	HIGH
	.10	709	812	--	--	891
	.20	689	784	--	--	854
	.30	670	759	--	--	827
	.40	647	727	--	--	788
	.50	622	700	--	--	755
	.60	590	661	--	--	717
.70	558	624	--	--	673	

NTN3100KFA/NBF100F20A, NTN3100KJA/NBF100J20A, NTG3100KFA/FBF100F20A & NTC6100KJ/GNE100J20 & NTC6100KJ/GNE100J20

External Static Pressure Inches of W.C.	Air Delivery in Cubic Feet per Minute (C.F.M.) (Furnace Rated @0.5" WC ESP)					
	TAP	LOW	MED L	MED	MED H	HIGH
	.10	1210	1441	--	1773	2104
	.20	1201	1430	--	1740	2078
	.30	1197	1453	--	1740	2061
	.40	1191	1441	--	1718	2020
	.50	1167	1425	--	1707	2005
	.60	1160	1390	--	1676	1953
.70	1130	1365	--	1654	1917	

External Static Pressure Inches of W.C.	Air Delivery in Liters Per Second (L/S) (Furnace Rated @0.5" WC ESP)					
	TAP	LOW	MED L	MED	MED H	HIGH
	.10	571	680	--	837	993
	.20	567	675	--	821	981
	.30	565	686	--	821	973
	.40	562	680	--	811	953
	.50	552	673	--	806	946
	.60	548	656	--	791	922
.70	533	644	--	781	905	

NTN3100LJA/NBF100J22A , NTG3100LJA/FBF100J22A, NTN3125LJA/NBF125J22A & NTG3125LJA/FBF125J22A

External Static Pressure Inches of W.C.	Air Delivery in Cubic Feet per Minute (C.F.M.) (Furnace Rated @0.5" WC ESP)					
	TAP	LOW	MED L	MED	MED H	HIGH
	.10	1598	1864	--	2131	2383
	.20	1586	1839	--	2086	2340
	.30	1574	1814	--	2048	2299
	.40	1550	1786	--	2018	2253
	.50	1516	1752	--	1976	2193
	.60	1481	1699	--	1914	2136
.70	1441	1630	--	1865	2072	

External Static Pressure Inches of W.C.	Air Delivery in Liters Per Second (L/S) (Furnace Rated @0.5" WC ESP)					
	TAP	LOW	MED L	MED	MED H	HIGH
	.10	754	880	--	1006	1125
	.20	749	868	--	984	1104
	.30	743	856	--	967	1084
	.40	732	843	--	952	1063
	.50	716	826	--	933	1035
	.60	699	803	--	903	1008
.70	680	769	--	880	978	

NTN3125KJA/NBF125J20A, NTG3125KJA/FBF125J20A & NTC6125KJ/GNE125J20, NTC6125KJ/GNE125J20

External Static Pressure Inches of W.C.	Air Delivery in Cubic Feet per Minute (C.F.M.) (Furnace Rated @0.5" WC ESP)					
	TAP	LOW	MED L	MED	MED H	HIGH
	.10	1264	1520	--	1841	2161
	.20	1251	1506	--	1803	2132
	.30	1249	1486	--	1772	2079
	.40	1219	1456	--	1736	2042
	.50	1168	1427	--	1702	1991
	.60	1178	1415	--	1672	1914
.70	1143	1358	--	1614	1838	

External Static Pressure Inches of W.C.	Air Delivery in Liters Per Second (L/S) (Furnace Rated @0.5" WC ESP)					
	TAP	LOW	MED L	MED	MED H	HIGH
	.10	597	1520	--	1841	2161
	.20	590	1506	--	1803	2132
	.30	1249	1486	--	1772	2079
	.40	1219	1456	--	1736	2042
	.50	1168	1427	--	1702	1991
	.60	1178	1415	--	1672	1914
.70	1143	1358	--	1614	1838	

NDN3050FB/NDF050B12, NDN3075FB/NDF075B12 & NDN6050FB/GDE050B12 & NDN6075FB/GDE075B12

External Static Pressure Inches of W.C.	Air Delivery in Cubic Feet per Minute (C.F.M.) (Furnace Rated @0.5" WC ESP)					
	TAP	LOW	MED L	MED	MED H	HIGH
	.10	675	859	--	1015	1394
	.20	662	846	--	999	1342
	.30	651	819	--	977	1289
	.40	636	795	--	952	1227
	.50	608	765	--	914	1163
	.60	564	735	--	870	1086
.70	514	685	--	818	1002	

External Static Pressure Inches of W.C.	Air Delivery in Liters Per Second (L/S) (Furnace Rated @0.5" WC ESP)					
	TAP	LOW	MED L	MED	MED H	HIGH
	.10	318	405	--	479	658
	.20	312	399	--	472	633
	.30	307	387	--	461	608
	.40	300	375	--	449	579
	.50	287	361	--	431	549
	.60	266	347	--	411	513
.70	243	323	--	386	473	

NDN3075HF/NDF075F16F & NDN6075HF/GDE075F16F

External Static Pressure Inches of W.C.	Air Delivery in Cubic Feet per Minute (C.F.M.) (Furnace Rated @0.5" WC ESP)					
	TAP	LOW	MED L	MED	MED H	HIGH
	.10	1512	--	1669	--	1840
	.20	1460	--	1610	--	1780
	.30	1402	--	1559	--	1711
	.40	1360	--	1499	--	1640
	.50	2191	--	1439	--	1572
	.60	1230	--	1360	--	1480
.70	1171	--	1270	--	1391	

External Static Pressure Inches of W.C.	Air Delivery in Liters Per Second (L/S) (Furnace Rated @0.5" WC ESP)					
	TAP	LOW	MED L	MED	MED H	HIGH
	.10	714	--	788	--	868
	.20	689	--	760	--	840
	.30	662	--	736	--	808
	.40	642	--	708	--	774
	.50	609	--	679	--	742
	.60	581	--	642	--	699
.70	553	--	603	--	657	

NDN3100GF/NDF100F14 & NDN6100GF/GDE100F14

External Static Pressure Inches of W.C.	Air Delivery in Cubic Feet per Minute (C.F.M.) (Furnace Rated @0.5" WC ESP)					
	TAP	LOW	MED L	MED	MED H	HIGH
	.10	778	984	--	1263	1576
	.20	786	1003	--	1249	1532
	.30	790	1003	--	1244	1489
	.40	788	1001	--	1215	1432
	.50	781	982	--	1186	1371
	.60	765	962	--	1146	1308
.70	743	923	--	1094	1229	

External Static Pressure Inches of W.C.	Air Delivery in Liters Per Second (L/S) (Furnace Rated @0.5" WC ESP)					
	TAP	LOW	MED L	MED	MED H	HIGH
	.10	367	464	--	596	744
	.20	371	473	--	589	723
	.30	373	473	--	587	703
	.40	372	472	--	573	676
	.50	369	463	--	560	647
	.60	361	454	--	541	617
.70	351	436	--	516	580	

NDN3100KF/NDF100F20 & NDN6100KF/GDE100F20

External Static Pressure Inches of W.C.	Air Delivery in Cubic Feet per Minute (C.F.M.) (Furnace Rated @0.5" WC ESP)					
	TAP	LOW	MED L	MED	MED H	HIGH
	.10	1305	1495	--	1805	2141
	.20	1258	1475	--	1743	2064
	.30	1241	1424	--	1698	1981
	.40	1227	1383	--	1636	1902
	.50	1178	1343	--	1563	1818
	.60	1103	1279	--	1491	1740
.70	1029	1185	--	1390	1644	

External Static Pressure Inches of W.C.	Air Delivery in Liters Per Second (L/S) (Furnace Rated @0.5" WC ESP)					
	TAP	LOW	MED L	MED	MED H	HIGH
	.10	616	706	--	852	1011
	.20	594	688	--	823	974
	.30	586	672	--	801	935
	.40	579	653	--	772	898
	.50	556	634	--	738	858
	.60	521	604	--	704	821
.70	486	559	--	656	776	

NDN3125KJ/NDF125J20 & NDN6125KJ/GDE125J20

External Static Pressure Inches of W.C.	Air Delivery in Cubic Feet per Minute (C.F.M.) (Furnace Rated @0.5" WC ESP)					
	TAP	LOW	MED L	MED	MED H	HIGH
	.10	1333	1573	--	1840	2148
	.20	1294	1544	--	1816	2093
	.30	1266	1500	--	1776	2041
	.40	1240	1467	--	1726	1981
	.50	1175	1419	--	1665	1906
	.60	1141	1357	--	1607	1828
.70	1054	1308	--	1538	1751	

External Static Pressure Inches of W.C.	Air Delivery in Liters Per Second (L/S) (Furnace Rated @0.5" WC ESP)					
	TAP	LOW	MED L	MED	MED H	HIGH
	.10	629	742	--	868	1014
	.20	611	729	--	857	988
	.30	598	708	--	838	963
	.40	585	692	--	815	935
	.50	555	670	--	786	900
	.60	539	641	--	759	863
.70	497	617	--	726	826	

NTC6100GF/GNE100F14

External Static Pressure Inches of W.C.	Air Delivery in Cubic Feet per Minute (C.F.M.) (Furnace Rated @0.5" WC ESP)					
	TAP	LOW	MED L	MED	MED H	HIGH
	.10	815	1043	--	1324	1649
	.20	783	1030	--	1302	1616
	.30	755	1021	--	1280	1592
	.40	735	989	--	1255	1546
	.50	704	968	--	1218	1502
	.60	668	941	--	1171	1425
.70	646	881	--	1100	1353	

External Static Pressure Inches of W.C.	Air Delivery in Liters Per Second (L/S) (Furnace Rated @0.5" WC ESP)					
	TAP	LOW	MED L	MED	MED H	HIGH
	.10	385	492	--	625	778
	.20	370	486	--	615	763
	.30	356	482	--	604	751
	.40	347	467	--	592	730
	.50	332	457	--	575	709
	.60	315	444	--	553	673
.70	305	415	--	519	639	

NTC6100KF/GNE100F20 & NTN6100KF/NNE100F20

External Static Pressure Inches of W.C.	Air Delivery in Cubic Feet per Minute (C.F.M.) (Furnace Rated @0.5" WC ESP)					
	TAP	LOW	MED L	MED	MED H	HIGH
	.10	1278	1546	--	1822	2302
	.20	1264	1543	--	1784	2731
	.30	1244	1499	--	1737	2171
	.40	1212	1471	--	1683	2098
	.50	1185	1417	--	1641	2012
	.60	1178	1367	--	1574	1921
.70	1119	1304	--	1495	1826	

External Static Pressure Inches of W.C.	Air Delivery in Liters Per Second (L/S) (Furnace Rated @0.5" WC ESP)					
	TAP	LOW	MED L	MED	MED H	HIGH
	.10	603	730	--	860	1087
	.20	597	728	--	842	1289
	.30	587	708	--	820	1025
	.40	572	694	--	794	990
	.50	559	669	--	775	950
	.60	556	645	--	743	907
.70	528	615	--	706	862	

NTC6150KJ/GNE150J20

External Static Pressure Inches of W.C.	Air Delivery in Cubic Feet per Minute (C.F.M.) (Furnace Rated @0.5" WC ESP)					
	TAP	LOW	MED L	MED	MED H	HIGH
	.10	1357	1542	--	1709	2073
	.20	1325	1525	--	1750	2040
	.30	1290	1503	--	1761	2014
	.40	1270	1480	--	1740	1975
	.50	1243	1464	--	1710	1953
	.60	1225	1430	--	1650	1885
.70	1195	1401	--	1602	1827	

External Static Pressure Inches of W.C.	Air Delivery in Liters Per Second (L/S) (Furnace Rated @0.5" WC ESP)					
	TAP	LOW	MED L	MED	MED H	HIGH
	.10	641	728	--	807	978
	.20	625	720	--	826	963
	.30	609	709	--	831	951
	.40	600	699	--	821	932
	.50	587	691	--	807	922
	.60	578	675	--	779	890
.70	564	661	--	756	862	

13. NTG3/FBF & NTN3/NBF

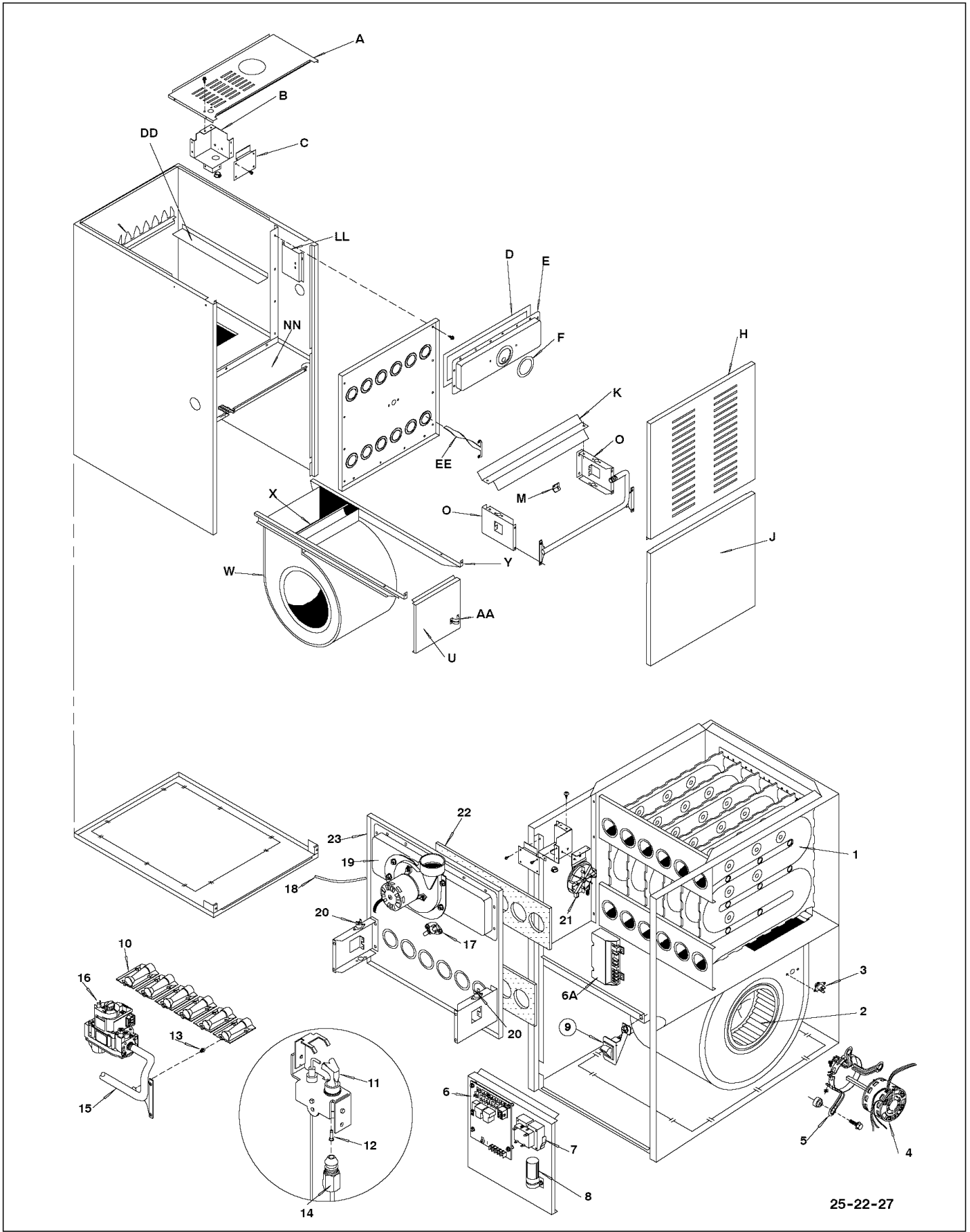

25-22-27

Replacement Parts - NTG3/FBF (Natural Gas)

Models – NTG3050FBG1, NTG3075FBG1, NTG3075HFG1, NTG3100GFG1, NTG3100KFG1, NTG3100LJG1, NTG3125KJG1, NTG3125LJG1: & FBF050B12G1, FBF075B12G1, FBF075F16G1, FBF100F14G1, FBF100F20G1, FBF100J22G1, FBF125J20G1, FBF125J22G1

Replacement part supplied will be current active part. For parts not listed, consult place of purchase.

Key No.	Description Functional	Part Number	NTG3/FBF								
			050FBG1/ 050B12G1	075FBG1/ 075B12G1	075HFG1/ 075F16G1	100GFG1/ 100F14G1	100LJG1/ 100J22G1	100KFG1/ 100F20G1	125KJG1/ 125J20G1	125LJG1/ 125J22G1	
1	Heat Exchanger	1011544	1	-	-	-	-	-	-	-	-
		1012406	-	1	-	-	-	-	-	-	-
		1012407	-	-	1	-	-	-	-	-	-
		1011364	-	-	-	1	-	1	-	-	-
		1011363	-	-	-	-	1	-	-	-	-
		1012408	-	-	-	-	-	-	1	1	-
2	Blower Wheel 10-10 DD	601210	-	-	1	1	-	-	-	-	-
		10-8 DD	600587	1	1	-	-	-	-	-	-
		11-10 DD	1011420	-	-	-	-	1	1	1	1
3	Switch, Auxiliary Limit	1000735	2	2	2	2	2	2	2	2	
4	Blower Motor 115V -1/3 HP	1012514	1	1	-	-	-	-	-	-	-
		115V -1/2 HP	1012119	-	-	1	-	-	-	-	-
		115V -1/3 HP	1013341	-	-	-	1	-	-	-	-
		115V -3/4 HP	1011906	-	-	-	-	1	-	-	1
		115V -3/4 HP	1010263	-	-	-	-	-	1	-	-
		115V -3/4 HP	1011404	-	-	-	-	-	-	1	-
5	Motor Mount Kit	609227	1	1	1	1	-	-	-	-	-
		522020024	-	-	-	-	1	1	1	1	1
6	Control, Fan Timer	1011927	1	1	1	1	1	1	1	1	
6A	Control, Module	1011449	1	1	1	1	1	1	1	1	
7	Transformer, 40VA	1012722	1	1	1	1	1	1	1	1	
8	Capacitor 5mf 370V	1094954	1	1	-	-	-	-	-	-	-
		10mf 370V	1094956	-	-	1	-	-	1	1	-
		7.5mf 370V	1094239	-	-	-	1	-	-	-	-
		40mf 370V	1012176	-	-	-	-	1	-	-	1
9	Switch Door	1010886	1	1	1	1	1	1	1	1	
10	Burner Assembly	1012382	1	-	-	-	-	-	-	-	-
		1012383	-	1	1	-	-	-	-	-	-
		1012384	-	-	-	1	1	1	-	-	-
		1012385	-	-	-	-	-	-	-	1	1
		1011477	1	1	1	1	1	1	1	1	1
12	Pilot Orifice, NAT (.018)	503211	1	1	1	1	1	1	1	1	
13	Orifice, #42 NAT	1011351	2	3	3	4	4	4	5	5	
14	Tube, Pilot	1011943	1	-	-	-	-	-	-	-	-
		1011044	-	1	1	1	1	1	-	-	-
		1011945	-	-	-	-	-	-	-	1	1
		1011458	1	-	-	-	-	-	-	-	-
15	Manifold	1011459	-	1	1	-	-	-	-	-	-
		1011460	-	-	-	1	1	1	-	-	-
		1011461	-	-	-	-	-	-	-	1	1
		1005597	1	1	1	1	1	1	1	1	1
		1320365	1	-	-	1	-	-	-	-	-
17	Switch, Limit 270°F	1009169	-	1	1	-	-	-	-	-	-
		150°F	1320364	-	-	-	-	1	-	-	-
		195°F	1320363	-	-	-	-	-	1	-	-
		190°F	1008445	-	-	-	-	-	-	1	-
		170°F	1095242	-	-	-	-	-	-	-	1
		2971255	1	1	1	1	1	1	1	1	1
18	Tubing, Silicone 24"	2971255	1	1	1	1	1	1	1	1	
19	Combustion Blower Assembly	1010975	1	1	1	1	1	1	1	1	
20	Rollout Switch, Limit	1094863	2	2	-	2	2	2	2	2	
		1005549	-	-	2	-	-	-	-	-	
21	Switch, Pressure	1010898	1	1	1	1	1	1	1	1	
22	Heat Exchanger Gaskets	2480904	2	-	-	-	-	-	-	-	-
		2480905	-	2	2	-	-	-	-	-	
		2480906	-	-	-	2	2	2	-	-	
		2480907	-	-	-	-	-	-	2	2	
		1011451	1	-	-	-	-	-	-	-	
23	Heat Exchanger Frt Partition	1012409	-	1	-	-	-	-	-	-	
		1012410	-	-	1	-	-	-	-	-	
		1008072	-	-	-	1	-	1	-	-	
		1008071	-	-	-	-	1	-	-	-	
		1012411	-	-	-	-	-	-	1	1	
		1012411	-	-	-	-	-	-	-	1	

Replacement Parts - NTG3/FBF (Natural Gas)

Models - NTG3050FBG1, NTG3075FBG1, NTG3075HFG1, NTG3100GFG1, NTG3100KFG1, NTG3100LJG1, NTG3125KJG1, NTG3125LJA: & FBF050B12G1, FBF075B12G1, FBF075F16G1, FBF100F14G1, FBF100F20G1, FBF100J22G1, FBF125J20G1, FBF125J22A

Replacement part supplied will be current active part. For parts not listed, consult place of purchase.

Key No.	Description Non-Functional	Part Number	NTG3/FBF							
			050FBG1/ 050B12G1	075FBG1/ 075B12G1	075HFG1/ 075F16G1	100GFG1/ 100F14G1	100LJG1/ 100J22G1	100KFG1/ 100F20G1	125KJG1/ 125J20G1	125LJG1/ 125J22G1
A	Top	1013295	1	1	-	-	-	-	-	-
		1013296	-	-	1	-	-	-	-	-
		1013297	-	-	-	1	-	1	-	-
		1013298	-	-	-	-	1	-	1	1
B	Field Connect Box	1011941	1	1	1	1	1	1	1	
C	Cover, Field Connect	1010360	1	1	1	1	1	1	1	
D	Gasket, Collector	1093661	1	1	1	-	-	-	-	-
		1093662	-	-	-	1	1	1	-	-
		1093663	-	-	-	-	-	-	1	1
E	Collector	1011045	1	-	-	-	-	-	-	-
		1011048	-	1	1	-	-	-	-	-
		1011052	-	-	-	1	1	1	-	-
		1011055	-	-	-	-	-	-	1	1
F	Gasket, Combustion Blower	1011379	1	1	1	1	1	1	1	
H	Door, Louvered	1013324	1	1	-	-	-	-	-	-
		1013316	-	-	1	1	-	1	-	-
		1013317	-	-	-	-	1	-	1	1
J	Door, Blower	1013303	1	1	-	-	-	-	-	-
		1013304	-	-	1	1	-	1	-	-
		1013305	-	-	-	-	1	-	1	1
K	Shield, Burner	1011335	1	1	1	-	-	-	-	-
		1011336	-	-	-	1	1	1	-	-
		1011337	-	-	-	-	-	-	1	1
M	Bracket, Pilot	1010901	1	1	1	1	1	1	1	
O	Manifold Support Bracket	1011820	2	2	2	2	2	2	2	
U	Fan Timer Bracket	1012321	1	1	1	1	1	1	1	
W	Blower Housing	1013131	1	1	-	-	-	-	-	-
		1013132	-	-	1	1	-	-	-	-
		1013128	-	-	-	-	1	1	1	1
X	Blower Cutoff	721020008	-	-	1	1	1	1	1	1
		721020013	1	1	-	-	-	-	-	-
Y	Blower Hanger	1010690	2	2	2	2	2	2	2	
AA	Strap Capacitor	1095020	1	1	1	1	-	1	1	-
		1095022	-	-	-	-	1	-	-	1
BB	Rail, Blower Slide	57059	2	2	2	2	2	2	2	
LL	Bracket, Control	1011448	1	1	1	1	1	1	1	
NN	Partition, Blower	1013456	1	1	-	-	-	-	-	-
		1013457	-	-	1	1	-	1	-	-
		1013461	-	-	-	-	1	-	1	1
)	PART NOT ILLUSTRATED									
)	Wire Harness Asy. Low Volt	1011868	1	1	1	1	1	1	1	
)	Manual, Homeowners	44102200105	1	1	1	1	1	1	1	
)	Manual, Installation & Tech	44101260301	1	1	1	1	1	1	1	

Replacement Parts - NTN3/NBF (Natural Gas)

Models - NTN3050FBG1, NTN3075FBG1, NTN3075HFG1, NTN3100KFG1, NTN3100KJG1, NTN3100LJG1, NTN3125KJG1, NTN3125LJG1: & NBF050B12G1, NBF075B12G1, NBF075F16G1, NBF100F14G1, NBF100F20G1, NBF100J22G1, NBF125J20G1, NBF125J22G1

Replacement part supplied will be current active part. For parts not listed, consult place of purchase.

Key No.	Description Functional	Part Number	NTN3/NBF								
			050FBG1/ 050B12G1	075FBG1/ 075B12G1	075HFG1/ 075F16G1	100KFG1/ 100F20G1	100KJG1/ 100J20G1	100LJG1/ 100J22G1	125KJG1/ 125J20G1	125LJG1/ 125J22G1	
1	Heat Exchanger	1011544	1	-	-	-	-	-	-	-	-
		1012406	-	1	-	-	-	-	-	-	-
		1012407	-	-	1	-	-	-	-	-	-
		1011364	-	-	-	1	-	-	-	-	-
		1011363	-	1	-	-	1	1	-	-	-
		1012408	-	-	-	-	-	-	1	1	1
2	Blower Wheel 10-10 DD	601210	-	-	1	-	-	-	-	-	-
		600587	1	1	-	-	-	-	-	-	-
		1011420	-	-	-	1	1	1	1	1	1
3	Switch, Auxiliary Limit	1000735	2	2	2	2	2	2	2	2	
4	Blower Motor 115V - ¹ / ₃ HP	1012514	1	1	-	-	-	-	-	-	-
		1012119	-	-	1	-	-	-	-	-	-
		1011404	-	-	-	-	1	-	1	-	-
		1010263	-	-	-	1	-	-	-	-	-
		1011906	-	-	-	-	-	1	-	-	1
5	Motor Mount Kit	609227	1	1	1	-	-	-	-	-	-
		522020024	-	-	-	1	1	1	1	1	1
6	Control, Fan Timer	1011927	1	1	1	1	1	1	1	1	
6A	Control, Module	1011449	1	1	1	1	1	1	1	1	
7	Transformer, 40VA	1012722	1	1	1	1	1	1	1	1	
8	Capacitor 10mf 370V	1094956	-	-	1	1	1	-	1	-	-
		1094954	1	1	-	-	-	-	-	-	-
		1012176	-	-	-	-	-	1	-	-	1
9	Switch Door	1010886	1	1	1	1	1	1	1	1	
		1012382	1	-	-	-	-	-	-	-	-
10	Burner Assembly	1012383	-	1	1	-	-	-	-	-	-
		1012384	-	-	-	1	1	1	-	-	-
		1012385	-	-	-	-	-	-	1	1	1
		1011477	1	1	1	1	1	1	1	1	1
11	Pilot/Ignitor Natural	1011477	1	1	1	1	1	1	1	1	
12	Pilot Orifice, NAT (.018)	503211	1	1	1	1	1	1	1	1	
13	Orifice, #42 NAT	1011351	2	3	3	4	4	4	5	5	
14	Tube, Pilot	1011943	1	-	-	-	-	-	-	-	-
		1011944	-	1	1	1	1	1	-	-	-
		1011945	-	-	-	-	-	-	1	1	1
15	Manifold	1011458	1	-	-	-	-	-	-	-	-
		1011459	-	1	1	-	-	-	-	-	-
		1011460	-	-	-	1	1	1	-	-	-
		1011461	-	-	-	-	-	-	1	1	1
16	Valve, Natural	1005597	1	1	1	1	1	1	1	1	
		1320365	1	-	-	-	-	-	-	-	-
17	Switch, Limit	1009169	-	1	1	-	-	-	-	-	-
		1320363	-	-	-	1	-	-	-	-	-
		1320364	-	-	-	-	1	1	-	-	-
		1008445	-	-	-	-	-	-	1	-	-
		1095242	-	-	-	-	-	-	-	-	1
		2971255	1	1	1	1	1	1	1	1	1
18	Tubing, Silicone 24"	2971255	1	1	1	1	1	1	1	1	
19	Combustion Blower Assem	1010975	1	1	1	1	1	1	1	1	
20	Rollout Switch, Limit	1094863	2	2	-	2	2	2	2	2	
		1005549	-	-	2	-	-	-	-	-	
21	Switch, Pressure	1010898	1	1	1	1	1	1	1	1	
22	Heat Exchanger Gaskets	2480904	2	-	-	-	-	-	-	-	
		2480905	-	2	2	-	-	-	-	-	
		2480906	-	-	-	2	2	2	-	-	
		2480907	-	-	-	-	-	-	2	2	
		1011451	1	-	-	-	-	-	-	-	
23	Heat Exchanger Frt Partition	1012409	-	1	-	-	-	-	-	-	
		1012410	-	-	1	-	-	-	-	-	
		1008072	-	-	-	1	-	-	-	-	
		1008071	-	-	-	-	1	1	-	-	
		1012411	-	-	-	-	-	-	1	1	
		1012411	-	-	-	-	-	-	1	1	

Replacement Parts - NTN3/NBF (Natural Gas)

Models - NTN3050FBG1, NTN3075FBG1, NTN3075HFG1, NTN3100KFG1, NTN3100KJG1, NTN3100LJG1, NTN3125KJG1, NTN3125LJG1: & NBF050B12G1, NBF075B12G1, NBF075F16G1, NBF100F14G1, NBF100F20G1, NBF100J22G1, NBF125J20G1, NBF125J22A

Replacement part supplied will be current active part. For parts not listed, consult place of purchase.

Key No.	Description Non-Functional	Part Number	NTN3/NBF								
			050FBG1/ 050B12G1	075FBG1/ 075B12G1	075HFG1/ 075F16G1	100KFG1/ 100F20G1	100KJG1/ 100J20G1	100LJG1/ 100J22G1	125KJG1/ 125J20G1	125LJG1/ 125J22G1	
A	Top	1013295	1	1	-	-	-	-	-	-	-
		1013296	-	-	1	-	-	-	-	-	-
		1013297	-	-	-	1	-	-	-	-	-
		1013298	-	-	-	-	1	1	1	1	1
B	Field Connect Box	1011941	1	1	1	1	1	1	1	1	
C	Cover, Field Connect	1010360	1	1	1	1	1	1	1	1	
D	Gasket, Collector	1093661	1	1	1	-	-	-	-	-	
		1093662	-	-	-	1	1	1	-	-	
		1093663	-	-	-	-	-	-	1	1	
E	Collector	1011047	1	-	-	-	-	-	-	-	
		1011050	-	1	1	-	-	-	-	-	
		1011053	-	-	-	1	1	1	-	-	
		1011056	-	-	-	-	-	-	1	1	
F	Gasket, Combustion Blower	1011379	1	1	1	1	1	1	1		
H	Door, Louvered	1013324	1	1	-	-	-	-	-	-	
		1013316	-	-	1	1	-	-	-	-	
		1013317	-	-	-	-	1	1	1	1	
J	Door, Blower	1013303	1	1	-	-	-	-	-	-	
		1013304	-	-	1	1	-	-	-	-	
		1013305	-	-	-	-	1	1	1	1	
K	Shield, Burner	1011335	1	1	1	-	-	-	-	-	
		1011336	-	-	-	1	1	1	-	-	
		1011337	-	-	-	-	-	-	1	1	
M	Bracket, Pilot	1010901	1	1	1	1	1	1	1		
O	Manifold Support Bracket	1011820	2	2	2	2	2	2	2		
U	Fan Timer Bracket	1012321	1	1	1	1	1	1	1		
W	Blower Housing	1013131	1	1	-	-	-	-	-	-	
		1013132	-	-	1	-	-	-	-	-	
		1013128	-	-	-	1	1	1	1	1	
X	Blower Cutoff	721020008	-	-	1	1	1	1	1		
		721020013	1	1	-	-	-	-	-		
Y	Blower Hanger	1010690	2	2	2	2	2	2	2		
AA	Strap Capacitor	1095020	1	1	1	1	1	-	1	-	
		1095022	-	-	-	-	-	1	-	1	
BB	Rail, Blower Slide	57059	2	2	2	2	2	2	2		
EE	NOx Baffle	1009876	2	3	3	4	4	4	5		
LL	Bracket, Control	1011448	1	1	1	1	1	1	1		
NN	Partition, Blower	1013456	1	1	-	-	-	-	-		
		1013457	-	-	1	1	-	-	-		
		1013461	-	-	-	-	1	1	1		
)	PART NOT ILLUSTRATED										
)	Wire Harness Asy. Low Volt	1011868	1	1	1	1	1	1	1		
)	Manual, Homeowners	441 02 2001 06	1	1	1	1	1	1	1		
)	Manual, Installation & Tech	441 01 2603 01	1	1	1	1	1	1	1		

14. NDN3/NDF

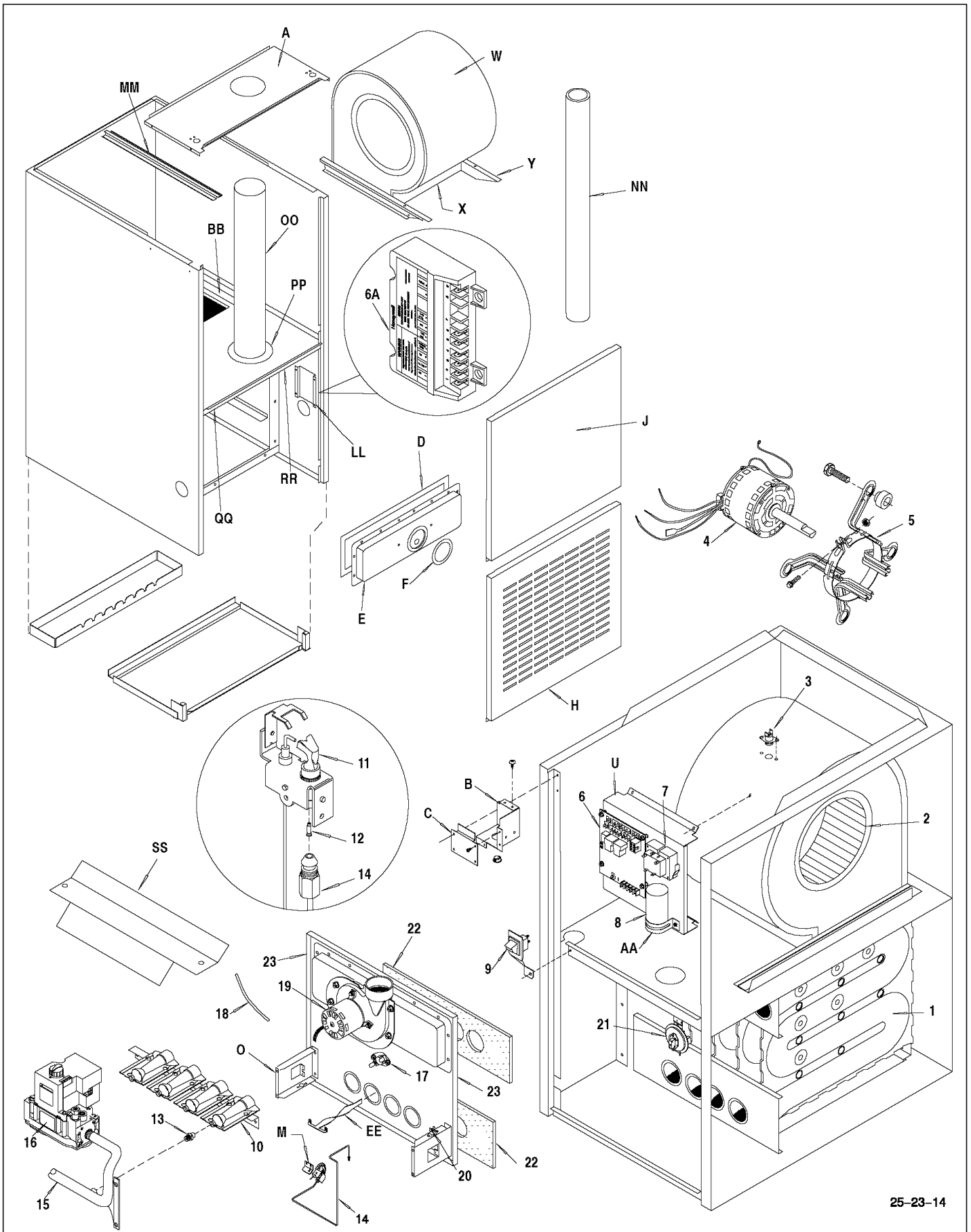

25-23-14

Replacement Parts - NDN3/NDF

Models - NDN3050FBG1, NDN3075FBG1, NDN3075HFG1, NDN3100GFG1, NDN3100KFG1, NDN3125KJG1
 NDF050B12G1, NDF075B12G1, NDF075F16G1, NDF100F14G1, NDF100F20G1, NDF125J20G1

Replacement part supplied will be current active part. For parts not listed, consult place of purchase.

Key No.	Description Functional	Part Number	NDN3/NDF					
			050FBG1/ 050B12G1	075FBG1/ 075B12G1	075HFG1/ 075F16G1	100GFG1/ 100F14G1	100KFG1/ 100F20G1	125KJG1/ 125J20G1
1	Heat Exch Assembly	1011544	1	-	-	-	-	-
		1012406	-	1	-	-	-	-
		1012407	-	-	1	-	-	-
		1011364	-	-	-	1	1	-
		1012408	-	-	-	-	-	1
2	Blower Wheel 10-10DD	601210	-	-	-	1	-	-
		600587	1	1	-	-	-	-
		1011420	-	-	1	-	1	1
3	Switch, Limit (Auxiliary)	1320368	1	1	1	1	1	1
4	Blower Motor 115V 1/3 HP	1012514	1	1	-	-	-	-
		1012119	-	-	1	-	-	-
		1013341	-	-	-	1	-	-
		1011404	-	-	-	-	-	1
		1010263	-	-	-	-	1	-
5	Motor Mount Kit	609227	1	1	-	1	-	-
		522020024	-	-	1	-	1	1
6	Control, Fan Timer	1011927	1	1	1	1	1	1
6A	Control Module	1011449	1	1	1	1	1	1
7	Transformer, 40VA	1012722	1	1	1	1	1	1
8	Capacitor 10mf 370V	1094956	-	-	1	-	1	1
		1094239	-	-	-	1	-	-
		1094954	1	1	-	-	-	-
9	Switch Door	1010886	1	1	1	1	1	1
10	Burner Assembly	1012382	1	-	-	-	-	-
		1012383	-	1	1	-	-	-
		1012384	-	-	-	1	1	-
		1012385	-	-	-	-	-	1
		1011477	1	1	1	1	1	1
11	Pilot, Natural & LP	1011477	1	1	1	1	1	1
12	Orifice, Pilot, Nat. (.018)	503211	1	1	1	1	1	1
13	Orifice, #42, Nat.	1011351	2	3	3	4	4	5
14	Tube, Pilot	1011943	1	-	-	-	-	-
		1011944	-	1	1	1	1	-
		1011945	-	-	-	-	-	1
15	Manifold	1011458	1	-	-	-	-	-
		1011459	-	1	1	-	-	-
		1011460	-	-	-	1	1	-
		1011461	-	-	-	-	-	1
		1005597	1	1	1	1	1	1
17	Switch, Limit 210°F	34335001	1	-	1	-	-	-
		1320366	-	-	-	1	-	-
		1320363	-	-	-	-	1	-
		1320367	-	1	-	-	-	-
		1065638	-	-	-	-	-	1
18	Tubing, Silicone, (24")	2971255	1	1	1	1	1	1
19	Combustion Blwr Assb.	1010975	1	1	1	1	1	1
20	Rollout Switch, Limit	1005549	1	1	1	1	1	1
21	Switch, Pressure	1010898	1	1	1	1	1	1
22	Gasket, Heat Exchanger	2480904	2	-	-	-	-	-
		2480905	-	2	2	-	-	-
		2480906	-	-	-	2	2	-
		2480907	-	-	-	-	-	2
23	Partition, Front Ht Exchanger	1011451	1	-	-	-	-	-
		1012409	-	1	-	-	-	-
		1012410	-	-	1	-	-	-
		1008072	-	-	-	1	1	-
		1012411	-	-	-	-	-	1

Replacement Parts - NDN3/NDF

Models - NDN3050FBG1, NDN3075FBG1, NDN3075HFG1, NDN3100GFG1, NDN3100KFG1, NDN3125KJG1
 NDF050B12G1, NDF075B12G1, NDF075F16G1, NDF100F14G1, NDF100F20G1, NDF125J20G1

Replacement part supplied will be current active part. For parts not listed, consult place of purchase.

Key No.	Description Non- Functional	Part Number	NDN3/NDF					
			050FBG1/ 050B12G1	075FBG1/ 075B12G1	075HFG1/ 075F16G1	100GFG1/ 100F14G1	100KFG1/ 100F20G1	125KJG1/ 125J20G1
A	Top	1013299	1	1	-	-	-	-
		1013302	-	-	1	-	-	-
		1013300	-	-	-	1	1	-
		1013301	-	-	-	-	-	1
B	Field Connect Box	1011941	1	1	1	1	1	1
C	Cover, Field Connect	1010360	1	1	1	1	1	1
D	Gasket, Collector	1093661	1	1	1	-	-	-
		1093662	-	-	-	1	1	-
		1093663	-	-	-	-	-	1
E	Collector	1011047	1	-	-	-	-	-
		1011050	-	1	1	-	-	-
		1011053	-	-	-	1	1	-
		1011056	-	-	-	-	-	1
F	Gasket, Combustion Blwr	1011379	1	1	1	1	1	1
H	Door, Louvered	1013334	1	1	-	-	-	-
		1013335	-	-	1	1	1	-
		1013336	-	-	-	-	-	1
J	Door, Blower	1013310	1	1	-	-	-	-
		1013311	-	-	1	1	1	-
		1013312	-	-	-	-	-	1
M	Bracket, Pilot	1010901	1	1	1	1	1	1
O	Manifold Support Bracket	1011820	2	2	2	2	2	2
U	Support, Control	1011178	1	1	1	1	1	1
W	Blower Housing	1010579	1	1	-	-	-	-
		1013129	-	-	1	-	1	1
		1010580	-	-	-	1	-	-
X	Blower Cutoff	721020008	-	-	1	1	1	1
		721020013	1	1	-	-	-	-
Y	Blower Hanger	33403100	2	2	2	2	2	2
AA	Clamp, Capacitor	1095020	1	1	1	1	1	1
BB	Rail, Blower Slide	33406100	2	2	2	2	2	2
EE	NOx Baffle	1009876	2	3	3	4	4	5
LL	Bracket, Ignition Module	1011448	1	1	1	1	1	1
MM	Filter Holder	33411100	1	1	1	1	1	1
NN	Flue Pipe	613193	1	1	1	1	1	1
OO	Vent Pipe Shield	2311160	1	1	1	1	1	1
PP	Vent Shield Endplate	57083	2	2	2	2	2	2
QQ	Plate, Fill-in	1011071	1	1	-	-	-	-
		1011072	-	-	1	1	1	-
		1011073	-	-	-	-	-	1
RR	Partition, Blower	1013476	1	1	-	-	-	-
		1013477	-	-	1	-	-	-
		1013474	-	-	-	1	1	-
		1013475	-	-	-	-	-	1
SS	Burner Shield	1011335	1	1	1	-	-	-
		1011336	-	-	-	1	1	-
		1011337	-	-	-	-	-	1
)	PART NOT ILLUSTRATED							
)	Wire Harness	1012720	1	1	1	1	1	1
)	Manual, Homeowners	44102200105	1	1	1	1	1	1
)	Manual, Installation	44101260300	1	1	1	1	1	1
)	Manual, Tech Support	44103260900	1	1	1	1	1	1

CONNECTION DIAGRAM

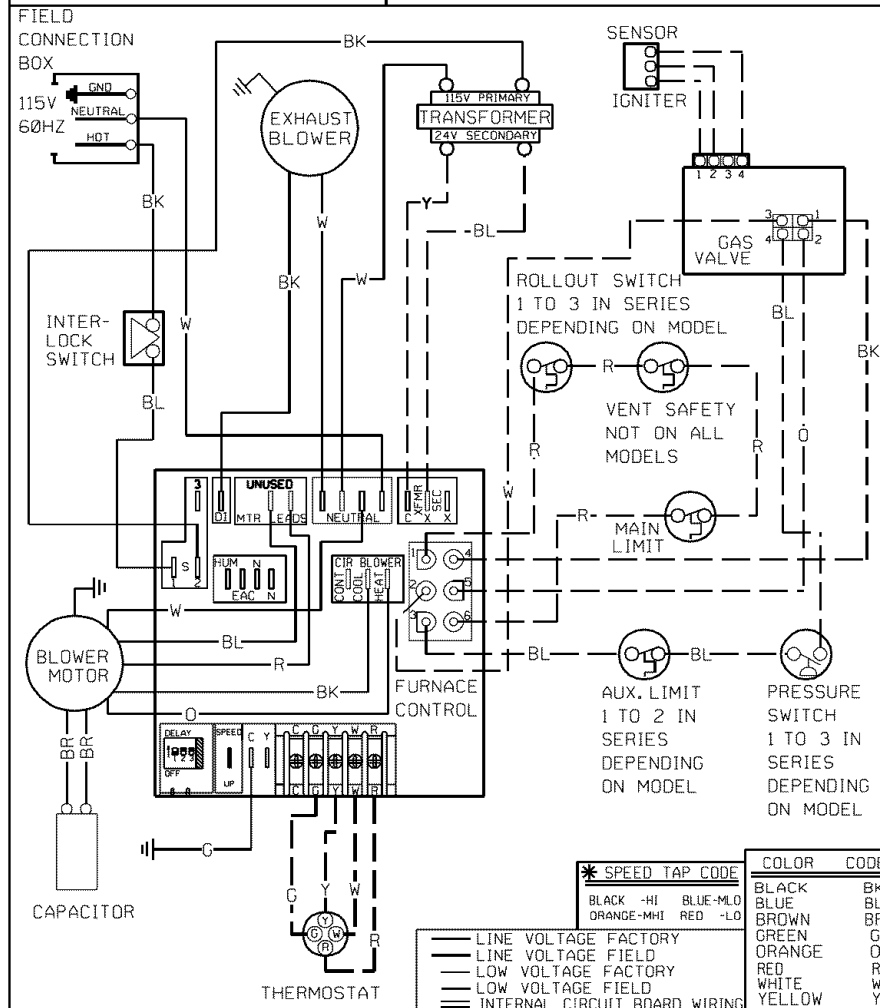

DANGER: ELECTRICAL SHOCK HAZARD
DISCONNECT BEFORE SERVICING

LADDER DIAGRAM

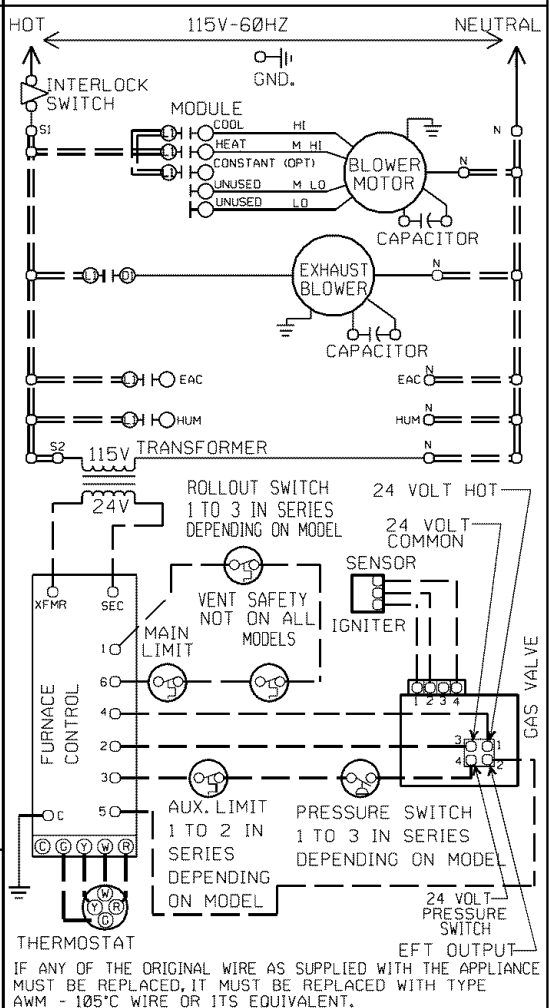

FAN CONTROL MODULE

EAC + HUM: 0.8 A MAX. COMBINED

FIELD TWINNING CONNECTIONS ARE ON EDGE OF CIRCUIT BOARD. USE TWINNING KIT NAH03WK01. MATCH Z1 AND Z2 CONNECTIONS TO SAME POINTS ON 2ND FURNACE CONTROL. ADD LOW VOLTAGE WIRING AND RELAY PER TWINNING KIT INSTRUCTION MANUAL.

60 SEC		COOL ON DELAY: 30 SEC.
180 SEC		COOL OFF DELAY: 30 SEC.
140 SEC		HEAT OFF DELAY
180 SEC		HEAT ON DELAY
60 SEC		OF CIRCUIT BOARD.
30 SEC		USE TWINNING KIT

* SEE TABLE IN MANUAL FOR C.F.M. VS. E.S.P. TO DETERMINE PROPER HEATING AND COOLING SPEED CONNECTIONS.

1011742-A

* SPEED TAP CODE	
BLACK -HI	BLUE-MLO
ORANGE-MHI	RED -LO

COLOR	CODE
BLACK	BK
BLUE	BL
BROWN	BR
GREEN	G
ORANGE	O
RED	R
WHITE	W
YELLOW	Y

- LINE VOLTAGE FACTORY
- LINE VOLTAGE FIELD
- LOW VOLTAGE FACTORY
- LOW VOLTAGE FIELD
- INTERNAL CIRCUIT BOARD WIRING

Replacement Parts - NTC6/GNE (Natural Gas)

Models - NTC6050FBG1, NTC6075FBG1, NTC6075HFG1, NTC6100GFG1, NTC6100KFG1, NTC6100KJG1, NTC6125KJG1, NTC6150KJG1: GNE050B12G1, GNE075B12G1, GNE075F16G1, GNE100F14G1, GNE100F20G1, GNE100J20G1, GNE125J20G1 & GNE150J20G1

Replacement part supplied will be current active part. For parts not listed, consult place of purchase.

Key No.	Functional Description	Part Number	NTC6/GNE							
			050FBG1/ 050B12G1	075FBG1/ 075B12G1	075HFG1/ 075F16G1	100GFG1/ 100F14G1	100KFG1/ 100F20G1	100KJG1/ 100J20G1	125KJG1/ 125J20G1	150KJG1/ 150J20G1
1	Heat Exchanger	1011544	1	-	-	-	-	-	-	-
		1012406	-	1	-	-	-	-	-	-
		1012407	-	-	1	-	-	-	-	-
		1011364	-	-	-	1	1	-	-	-
		1011363	-	-	-	-	-	1	-	-
		1012408	-	-	-	-	-	-	1	-
2	Blower Wheel 10-10DD	601210	-	-	1	1	-	-	-	-
		600587	1	1	-	-	-	-	-	-
		1011420	-	-	-	-	1	1	1	-
		1011433	-	-	-	-	-	-	-	1
		1011433	-	-	-	-	-	-	-	1
3	Switch, Auxiliary Limit	1000735	2	2	2	2	2	2	2	
		1012514	1	1	-	-	-	-	-	-
4	Blower Motor 115V 1/3 HP	1012119	-	-	1	-	-	-	-	-
		1013341	-	-	-	1	-	-	-	-
		1011404	-	-	-	-	-	1	1	1
		1010263	-	-	-	-	1	-	-	-
		1010263	-	-	-	-	1	-	-	-
5	Motor Mount Kit	609227	1	1	1	1	-	-	-	-
		522020024	-	-	-	-	1	1	1	-
		1002804	-	-	-	-	-	-	-	1
6	Control, Fan Timer	1011927	1	1	1	1	1	1	1	
7	Transformer, 40VA	1012722	1	1	1	1	1	1	1	
8	Capacitor 10mf 370V	1094956	-	-	1	-	1	1	1	1
		1094954	1	1	-	-	-	-	-	-
		1094239	-	-	-	1	-	-	-	-
9	Switch Door	1010886	1	1	1	1	1	1	1	
		1012382	1	-	-	-	-	-	-	-
10	Burner Assembly	1012383	-	1	1	-	-	-	-	-
		1012384	-	-	-	1	1	1	-	-
		1012385	-	-	-	-	-	-	1	-
		1013066	-	-	-	-	-	-	-	1
		1008731	1	1	1	1	1	1	1	1
11	Pilot, Natural & LP	1008731	1	1	1	1	1	1	1	
12	Pilot Orifice, NAT (.018)	503211	1	1	1	1	1	1	1	
13	Orifice, #42 NAT	1011351	2	3	3	4	4	5	6	
14	Tube, Pilot	1011943	1	-	-	-	-	-	-	-
		1011944	-	1	1	1	1	1	-	-
		1011945	-	-	-	-	-	-	1	1
15	Manifold	1011458	1	-	-	-	-	-	-	-
		1011459	-	1	1	-	-	-	-	-
		1011460	-	-	-	1	1	1	-	-
		1011461	-	-	-	-	-	-	1	-
		1011462	-	-	-	-	-	-	-	1
16	Valve, Natural & LP	1011421	1	1	1	1	1	1	1	
17	Switch, Limit 270°F	1320365	1	-	-	1	-	-	-	-
		1320363	-	-	-	-	1	-	-	-
		1320364	-	-	-	-	-	1	-	-
		1320362	-	-	-	-	-	-	-	1
		1009169	-	1	1	-	-	-	-	-
		1008445	-	-	-	-	-	-	1	-
18	Tubing, Silicone 24"	2971255	1	1	1	1	1	1	1	
19	Combustion Blower Assem	1010975	1	1	1	1	1	1	1	
20	Rollout Switch, Limit	1005549	2	2	2	2	2	2	2	
21	Switch, Pressure	1010898	1	1	1	1	1	1	1	
22	Heat Exchanger Gaskets	2480904	2	-	-	-	-	-	-	-
		2480905	-	2	2	-	-	-	-	-
		2480906	-	-	-	2	2	2	-	-
		2480907	-	-	-	-	-	-	2	-
		2480908	-	-	-	-	-	-	-	2
23	Heat Exchanger Frt Partition	1008068	1	-	-	-	-	-	-	-
		1008072	-	-	-	1	1	-	-	-
		1008071	-	-	-	-	-	1	-	-
		1008074	-	-	-	-	-	-	-	1
		1012409	-	1	-	-	-	-	-	-
		1012410	-	-	1	-	-	-	1	-
28	Ignitor/Sensor with clip	1009524	1	1	1	1	1	1	1	
		1009524	1	1	1	1	1	1	1	

Replacement Parts - NTC6/GNE (Natural Gas)

Models – NTC6050FBG1, NTC6075FBG1, NTC6075HFG1, NTC6100GFG1, NTC6100KFG1, NTC6100KJG1, NTC6125KJG1, NTC6150KJG1: GNE050B12G1, GNE075B12G1, GNE075F16G1, GNE100F14G1, GNE100F20G1, GNE100J20G1, GNE125J20G1 & GNE150J20G1

Replacement part supplied will be current active part. For parts not listed, consult place of purchase.

Key No.	Non-Functional Description	Part Number	NTC6/GNE							
			050FBG1/ 050B12G1	075FBG1/ 075B12G1	075HFG1/ 075F16G1	100GFG1/ 100F14G1	100KFG1/ 100F20G1	100KJG1/ 100J20G1	125KJG1/ 125J20G1	150KJG1/ 150J20G1
A	Top	1013295	1	1	-	-	-	-	-	-
		1013296	-	-	1	-	-	-	-	-
		1013297	-	-	-	1	1	-	-	-
		1013298	-	-	-	-	-	1	1	1
B	Field Connect Box	1011941	1	1	1	1	1	1	1	1
C	Cover, Field Connect	1010360	1	1	1	1	1	1	1	1
D	Gasket, Collector	1093661	1	1	1	-	-	-	-	-
		1093662	-	-	-	1	1	1	-	-
		1093663	-	-	-	-	-	-	1	1
E	Collector	1011045	1	-	-	-	-	-	-	-
		1011048	-	1	1	-	-	-	-	-
		1011052	-	-	-	1	1	1	-	-
		1011055	-	-	-	-	-	-	1	-
		1011057	-	-	-	-	-	-	-	1
F	Gasket, Combustion Blower	1011379	1	1	1	1	1	1	1	1
H	Door, Louvered NTC6 only	1013331	1	1	-	-	-	-	-	-
		1013332	-	-	1	1	1	-	-	-
		1013333	-	-	-	-	-	1	1	1
		1013325	1	1	-	-	-	-	-	-
		1013326	-	-	1	1	1	-	-	-
1013327	-	-	-	-	-	1	1	1		
J	Door, Blower	1013303	1	1	-	-	-	-	-	-
		1013304	-	-	1	1	1	-	-	-
		1013305	-	-	-	-	-	1	1	1
M	Bracket, Pilot	1010901	1	1	1	1	1	1	1	1
O	Manifold Support Bracket	1011450	2	2	2	2	2	2	2	2
U	Fan Timer Bracket	1012321	1	1	1	1	1	1	1	1
W	Blower Housing	1013131	1	1	-	-	-	-	-	-
		1013132	-	-	1	1	-	-	-	-
		1013128	-	-	-	-	1	1	1	-
		1013130	-	-	-	-	-	-	-	1
X	Blower Cutoff	72102008	-	-	1	1	1	1	1	-
		721020013	1	1	-	-	-	-	-	-
		721020015	-	-	-	-	-	-	-	1
Y	Blower Hanger	1010690	2	2	2	2	2	2	2	-
		1011921	-	-	-	-	-	-	-	-
AA	Strap Capacitor	1095020	1	1	1	1	1	1	1	1
BB	Rail, Blower Slide	57059	2	2	2	2	2	2	2	2
NN	Partition, Blower	1013456	1	1	-	-	-	-	-	-
		1013457	-	-	1	1	1	-	-	-
		1013461	-	-	-	-	-	1	1	-
		1013458	-	-	-	-	-	-	-	1
OO	Baffle, Burner Box	1011454	1	1	1	-	-	-	-	-
		1011455	-	-	-	1	1	1	-	-
		1011456	-	-	-	-	-	-	1	-
		1011457	-	-	-	-	-	-	-	1
		1011768	1	1	1	-	-	-	-	-
PP	Top, Burner Box	1011769	-	-	-	1	1	1	-	-
		1011770	-	-	-	-	-	-	1	-
		1011771	-	-	-	-	-	-	-	1
		1011771	-	-	-	-	-	-	-	1
QQ	Cover, Burner Box	1011469	1	1	1	-	-	-	-	-
		1011470	-	-	-	1	1	1	-	-
		1011471	-	-	-	-	-	-	1	-
		1011472	-	-	-	-	-	-	-	1
RR	Sightglass	1011781	1	1	1	1	1	1	1	1
)	PART NOT ILLUSTRATED									
)	Wire Harness Asy. Low Volt	1011861	1	1	1	1	1	1	1	1
)	Fuse	1083348	1	1	1	1	1	1	1	1
)	Manual, Homeowners	44102200105	1	1	1	1	1	1	1	1
)	Manual, Installation & Tech	44101230802	1	1	1	1	1	1	1	1

Replacement Parts - NTN6/NNE (Natural Gas)

Models - NTN6050FBG1, NTN6075FBG1, NTN6075HFG1, NTN6100KFG1, NTN6100KJG1, NTN6125KJG1:
 NNE050B12G1, NNE075B12G1, NNE075F16G1, NNE100F20G1, NNE100J20G1 & NNE125J20G1

Replacement part supplied will be current active part. For parts not listed, consult place of purchase.

Key No.	Functional Description	Part Number	NTN6/NNE					
			050FBG1/ 050B12G1	075FBG1/ 075B12G1	075HFG1/ 075F16G1	100KFG1/ 100F20G1	100KJG1/ 100J20G1	125KJG1/ 125J20G1
1	Heat Exchanger	1011544	1	-	-	-	-	-
		1011364	-	-	-	1	-	-
		1011363	-	-	-	-	1	-
		1012406	-	1	-	-	-	-
		1012407	-	-	1	-	-	-
		1012408	-	-	-	-	-	1
2	Blower Wheel 10-10DD	601210	-	-	1	-	-	-
		600587	1	1	-	-	-	-
		1011420	-	-	-	1	1	1
3	Switch, Auxiliary Limit	1000735	2	2	2	2	2	
		4	Blower Motor	115V 1/3 HP	1012514	1	1	-
115V 1/2 HP	1012119	-		-	1	-	-	-
115V 3/4 HP	1011404	-		-	-	-	1	1
115V 3/4 HP	1010263	-		-	-	1	-	-
5	Motor Mount Kit	609227	1	1	1	-	-	-
		522020024	-	-	-	1	1	1
6	Control, Fan Timer	1011927	1	1	1	1	1	1
7	Transformer, 40VA	1012722	1	1	1	1	1	1
8	Capacitor 10mf 370V	1094956	-	-	1	1	1	1
		1094954	1	1	-	-	-	-
9	Switch Door	1010886	1	1	1	1	1	1
10	Burner Assembly	1012382	1	-	-	-	-	-
		1012383	-	1	1	-	-	-
		1012384	-	-	-	1	1	-
		1012385	-	-	-	-	-	1
11	Pilot, Natural & LP	1008731	1	1	1	1	1	1
12	Pilot Orifice, NAT (.018)	503211	1	1	1	1	1	1
13	Orifice, #42 NAT	1011351	2	3	3	4	4	5
14	Tube, Pilot	1011943	1	-	-	-	-	-
		1011944	-	1	1	1	1	-
		1011945	-	-	-	-	-	1
15	Manifold	1011458	1	-	-	-	-	-
		1011459	-	1	1	-	-	-
		1011460	-	-	-	1	1	-
		1011461	-	-	-	-	-	1
16	Valve, Natural & LP	1011421	1	1	1	1	1	1
17	Switch, Limit	270°F	1320365	1	-	-	-	-
		145°F	1320363	-	-	-	1	-
		130°F	1320364	-	-	-	-	1
		250°F	1009169	-	1	1	-	-
		140°F	1008445	-	-	-	-	-
18	Tubing, Silicone 24"	2971255	1	-	1	1	1	1
19	Combustion Blower Assembly	1010975	1	1	1	1	1	1
20	Rollout Switch, Limit	1005549	2	2	2	2	2	2
21	Switch, Pressure	1010898	1	1	1	1	1	1
22	Heat Exchanger Gaskets	2480904	2	-	-	-	-	-
		2480905	-	2	2	-	-	-
		2480906	-	-	-	2	2	-
		2480907	-	-	-	-	-	2
		1008068	1	-	-	-	-	-
23	Heat Exchanger Front Partition	1012409	-	1	-	-	-	
		1012410	-	-	1	-	-	
		1008072	-	-	-	1	-	
		1008071	-	-	-	-	1	
		1012411	-	-	-	-	-	1
		1009524	1	1	1	1	1	1
28	Ignitor/Sensor with clip	1009524	1	1	1	1	1	1

Replacement Parts - NTN6/NNE (Natural Gas)

Models - NTN6050FBG1, NTN6075FBG1, NTN6075HFG1, NTN6100KFG1, NTN6100KJG1, NTN6125KJG1:
 NNE050B12G1, NNE075B12G1, NNE075F16G1, NNE100F20G1, NNE100J20G1 & NNE125J20G1

Replacement part supplied will be current active part. For parts not listed, consult place of purchase.

Key No.	Non-Functional Description	Part Number	NTN6/NNE					
			050FBG1/ 050B12G1	075FBG1/ 075B12G1	075HFG1/ 075F16G1	100KFG1/ 100F20G1	100KJG1/ 100J20G1	125KJG1/ 125J20G1
A	Top	1013295	1	1	-	-	-	-
		1013296	-	-	1	-	-	-
		1013297	-	-	-	1	-	-
		1013298	-	-	-	-	1	1
B	Field Connect Box	1011941	1	1	1	1	1	
C	Cover, Field Connect	1010360	1	1	1	1	1	
D	Gasket, Collector	1093661	1	1	1	-	-	-
		1093662	-	-	-	1	1	-
		1093663	-	-	-	-	-	1
E	Collector	1011047	1	-	-	-	-	-
		1011050	-	1	1	-	-	-
		1011053	-	-	-	1	1	-
		1011056	-	-	-	-	-	1
F	Gasket, Combustion Blower	1011379	1	1	1	1	1	
H	Door, Louvered	1013331	1	1	-	-	-	-
		1013332	-	-	1	1	-	-
		1013333	-	-	-	-	1	1
J	Door, Blower	1013303	1	1	-	-	-	-
		1013304	-	-	1	1	-	-
		1013305	-	-	-	-	1	1
M	Bracket, Pilot	1010901	1	1	1	1	1	
O	Manifold Support Bracket	1011450	2	2	2	2	2	
U	Fan Timer Bracket	1012321	1	1	1	1	1	
W	Blower Housing	1013131	1	1	-	-	-	-
		1013132	-	-	1	-	-	-
		1013128	-	-	-	1	1	1
		721020008	-	-	1	1	1	1
X	Blower Cutoff	721020013	1	1	-	-	-	-
		1010690	2	2	2	2	2	2
Y	Blower Hanger	1010690	2	2	2	2	2	
AA	Strap Capacitor	1095020	1	1	1	1	1	
BB	Rail, Blower Slide	57059	2	2	2	2	2	
EE	Baffle, NOx	1009876	2	3	3	4	4	
NN	Partition, Blower	1013456	1	1	-	-	-	-
		1013457	-	-	1	1	-	-
		1013461	-	-	-	-	1	1
OO	Baffle, Burner Box	1011454	1	1	1	-	-	-
		1011455	-	-	-	1	1	-
		1011456	-	-	-	-	-	1
PP	Top, Burner Box	1011768	1	1	1	-	-	-
		1011769	-	-	-	1	1	-
		1011770	-	-	-	-	-	1
QQ	Cover, Burner Box	1011469	1	1	1	-	-	-
		1011470	-	-	-	1	1	-
		1011471	-	-	-	-	-	1
RR	Sightglass	1011781	1	1	1	1	1	
)	PART NOT ILLUSTRATED							
)	Wire Harness Asy. Low Volt	1011861	1	1	1	1	1	
)	Fuse (5 Amp.)	1083348	1	1	1	1	1	
)	Manual, Homeowners	44102200106	1	1	1	1	1	
)	Manual, Installation & Tech	44101230802	1	1	1	1	1	

NDN6/GDE

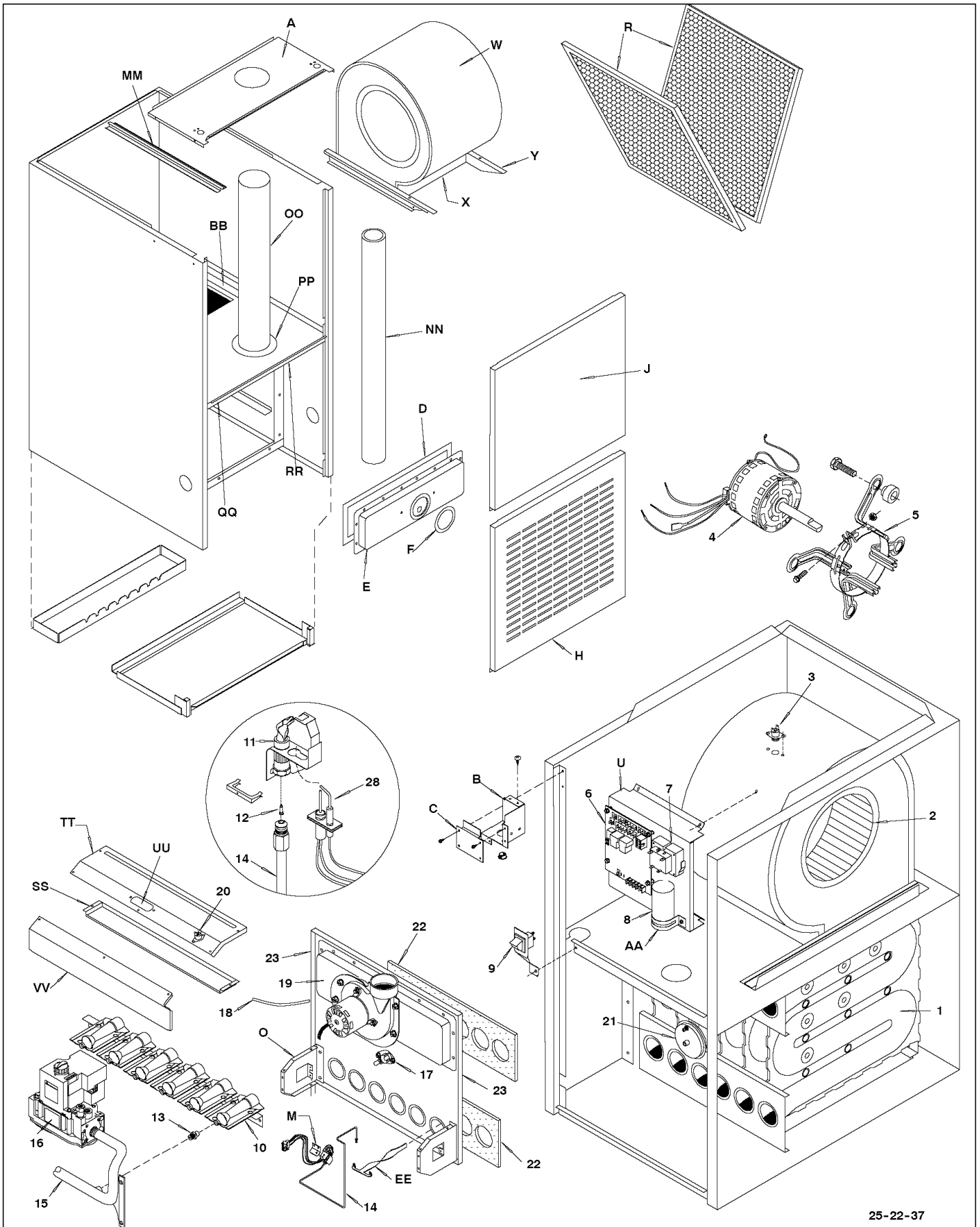

25-22-37

Replacement Parts - NDN6/GDE

Models - NDN6050FBG1, NDN6075FBG1, NDN6075HFG1, NDN6100GFG1, NDN6100KFG1, NDN6125KJG1
 GDE050B12G1, GDE075B12G1, GDE075F16G1, GDE100F14G1, GDE100F20G1, GDE125J20G1

Replacement part supplied will be current active part. For parts not listed, consult place of purchase.

Key No.	Description Functional	Part Number	NDN6/GDE					
			050FBG1/ 050B12G1	075FBG1/ 075B12G1	075HFG1/ 075F16G1	100GFG1/ 100F14G1	100KFG1/ 100F20G1	125KJG1/ 125J20G1
1	Heat Exch Assembly	1011544	1	-	-	-	-	-
		1011364	-	-	-	1	1	-
		1012406	-	1	-	-	-	-
		1012407	-	-	1	-	-	-
		1012408	-	-	-	-	-	1
2	Blower Wheel 10-10DD	601210	-	-	-	1	-	-
		600587	1	1	-	-	-	-
		1011420	-	-	1	-	1	1
3	Switch, Limit (Auxiliary)	1320368	1	1	1	1	1	1
		1012514	1	1	-	-	-	-
4	Blower Motor 115V 1/3 HP	1012119	-	-	1	-	-	-
		1012513	-	-	-	1	-	-
		1011404	-	-	-	-	-	1
		1010263	-	-	-	-	1	-
		1010263	-	-	-	-	-	-
5	Motor Mount Kit	609227	1	1	-	1	-	-
		522020024	-	-	1	-	1	1
6	Control, Fan Timer	1011927	1	1	1	1	1	1
7	Transformer, 40VA	1011626	1	1	1	1	1	1
8	Capacitor 10mf 370V	1094956	-	-	1	-	1	1
		1094239	-	-	-	1	-	-
		1094954	1	1	-	-	-	-
9	Switch Door	1010886	1	1	1	1	1	1
10	Burner Assembly	1008723	1	-	-	-	-	-
		1008724	-	1	1	-	-	-
		1008725	-	-	-	1	1	-
		1008726	-	-	-	-	-	1
11	Pilot, Natural & LP	1008731	1	1	1	1	1	1
12	Orifice, Pilot, Nat. (.018)	503211	1	1	1	1	1	1
		1009136	1	1	1	1	1	1
13	Orifice, #42, Nat.	1011351	2	3	3	4	4	5
		1011376	2	3	3	4	4	5
14	Tube, Pilot	64930	1	1	1	1	1	1
15	Manifold	1011458	1	-	-	-	-	-
		1011459	-	1	1	-	-	-
		1011460	-	-	-	1	1	-
		1011461	-	-	-	-	-	1
16	Valve, Natural + LP	1011421	1	1	1	1	1	1
		34335001	1	-	-	-	-	-
17	Switch, Limit 210°F	1320366	-	-	1	1	-	-
		1320363	-	-	-	-	1	-
		1320367	-	1	-	-	-	-
		1065638	-	-	-	-	-	1
		1065638	-	-	-	-	-	-
18	Tubing, Silicone, (24")	1149483	1	1	1	1	1	1
19	Combustion Blwr Assb.	1010975	1	1	1	1	1	1
20	Rollout Switch, Limit	1005549	1	1	1	1	1	1
21	Switch, Pressure	1010898	1	1	1	1	1	1
22	Gasket, Heat Exchanger	2480904	2	-	-	-	-	-
		2480905	-	2	2	-	-	-
		2480906	-	-	-	2	2	-
		2480907	-	-	-	-	-	2
23	Partition, Front Ht Exchanger	1008068	1	-	-	-	-	-
		1008072	-	-	-	1	1	-
		1012409	-	1	-	-	-	-
		1012410	-	-	1	-	-	-
		1012411	-	-	-	-	-	1
28	Ignitor/Sensor with clip	1009524	1	1	1	1	1	1

* Parts for models converted to LP Gas using the appropriate LP Kit.

Replacement Parts - NDN6/GDE

Models - NDN6050FBG1, NDN6075FBG1, NDN6075HFG1, NDN6100GFG1, NDN6100KFG1, NDN6125KJG1
 GDE050B12G1, GDE075B12G1, GDE075F16G1, GDE100F14G1, GDE100F20G1, GDE125J20G1

Replacement part supplied will be current active part. For parts not listed, consult place of purchase.

Key No.	Description Non-Functional	Part Number	NDN6/GDE					
			050FBG1/ 050B12G1	075FBG1/ 075B12G1	075HFG1/ 075F16G1	100GFG1/ 100F14G1	100KFG1/ 100F20G1	125KJG1/ 125J20G1
A	Top	1013299	1	1	-	-	-	-
		1013302	-	-	1	-	-	-
		1013300	-	-	-	1	1	-
		1013301	-	-	-	-	-	1
		1011941	1	1	1	1	1	1
B	Field Connect Box	1011941	1	1	1	1	1	
C	Cover, Field Connect	1010360	1	1	1	1	1	
D	Gasket, Collector	1093661	1	1	1	-	-	-
		1093662	-	-	-	1	1	-
		1093663	-	-	-	-	-	1
		1011047	1	-	-	-	-	-
E	Collector	1011050	-	1	1	-	-	-
		1011053	-	-	-	1	1	-
		1011056	-	-	-	-	-	1
		1011379	1	1	1	1	1	1
F	Gasket, Combustion Blwr	1011379	1	1	1	1	1	
H	Door, Louvered	1013334	1	1	-	-	-	-
		1013335	-	-	1	1	1	-
		1013336	-	-	-	-	-	1
J	Door, Blower	1013310	1	1	-	-	-	-
		1013311	-	-	1	1	1	-
		1013312	-	-	-	-	-	1
M	Bracket, Pilot	1010901	1	1	1	1	1	
O	Manifold Support Bracket	1011450	2	2	2	2	2	
R	Filter 18 ¹ / ₄ "X15 ³ / ₄ "X1"	1009750	2	2	2	2	2	
U	Support, Control	1011178	1	1	1	1	1	
W	Blower Housing	1010579	1	1	-	-	-	-
		1013129	-	-	1	-	1	1
		1010580	-	-	-	1	-	-
X	Blower Cutoff	721020008	-	-	1	1	1	1
		721020013	1	1	-	-	-	-
Y	Blower Hanger	33403100	2	2	2	2	2	
AA	Clamp, Capacitor	1095020	1	1	1	1	1	
BB	Rail, Blower Slide	33406100	2	2	2	2	2	
EE	NOx Baffle	1009876	2	3	3	4	4	
MM	Filter Holder	33411100	1	1	1	1	1	
NN	Flue Pipe	613193	1	1	1	1	1	
OO	Vent Pipe Shield	2311160	1	1	1	1	1	
PP	Vent Shield Endplate	57083	2	2	2	2	2	
QQ	Plate, Fill-in	1011071	1	1	-	-	-	-
		1011072	-	-	1	1	1	-
		1011073	-	-	-	-	-	1
RR	Partition, Blower	1013476	1	1	-	-	-	-
		1013477	-	-	1	-	-	-
		1013474	-	-	-	1	1	-
		1013475	-	-	-	-	-	1
SS	Baffle, Burner Box	1011454	1	1	1	-	-	-
		1011455	-	-	-	1	1	-
		1011456	-	-	-	-	-	1
TT	Top, Burner Box	1011772	1	1	1	-	-	-
		1011773	-	-	-	1	1	-
		1011774	-	-	-	-	-	1
UU	Sightglass	1011781	1	1	1	1	1	
VV	Cover, Burner Box	1011469	1	1	1	-	-	-
		1011470	-	-	-	1	1	-
		1011471	-	-	-	-	-	1
)	PART NOT ILLUSTRATED							
)	Wire Harness Asy.	1012203	1	1	1	1	1	
)	Fuse	1083348	1	1	1	1	1	
)	Manual, Homeowners	44102200106	1	1	1	1	1	
)	Manual, Installation & Tech	44101230802	1	1	1	1	1	