

Installation Instructions

Downflow Kit for EBP, EBX, EBW and EBV Series

These instructions must be read and understood completely before attempting installation.

WARNING

Fire Hazard

The purpose of the subbase assembly is to maintain a 1" clearance to combustible materials.

Attach supply duct to inner flange of subbase.

Failure to do so can result in fire, bodily injury or death.

WARNING: Before beginning any installation or modification, be sure the main electrical disconnect switch is in the OFF position. Tag the disconnect switch with a suitable warning label. Electrical shock can cause personal injury or death.

INTRODUCTION

Fan coils are factory-shipped for upflow or horizontal-left applications. This instruction covers the installation of downflow conversion kit on models EBP, EBX, EBW and EBV fan coils. The kit provides a means of installing fan coils in a downflow position.

DESCRIPTION AND USAGE

The downflow conversion kits are available for use on slope and A-coil versions of previously mentioned fan coils. When installed, the kit will provide proper condensate water drainage, as well as a means of supporting the coil. See unit Installation Instructions for proper kit part numbers.

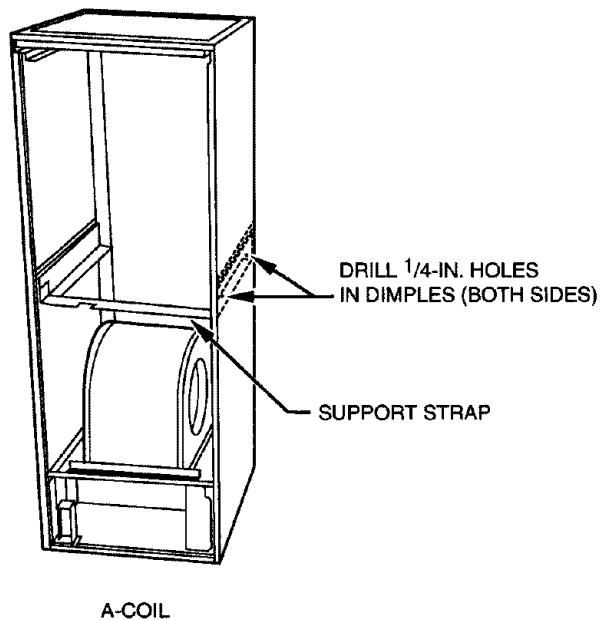

→ Fig. 1—Downflow A-Coil Brackets and Support Strap Location

The downflow conversion for slope units requires the following items:

Coil bracket	(1)
Coil baffle	(1)
Screws	(2)
Foam gasket	(1)

The downflow conversion for A-coil units requires the following items:

Coil bracket	(2)
Support strap	(1)
Drainage hole plugs	(2)
Angle	(2)
Screws	(4)
Air seal	(1)

NOTE: The fan coils are factory shipped for upflow or horizontal-left applications. Installation of the Downflow Conversion Kit should be complete before the fan coil unit is positioned to ensure side access required for installation of the coil brackets.

NOTE: If unit has electric heat with a circuit breaker, refer to electric heater Installation Instructions for repositioning of breaker assembly.

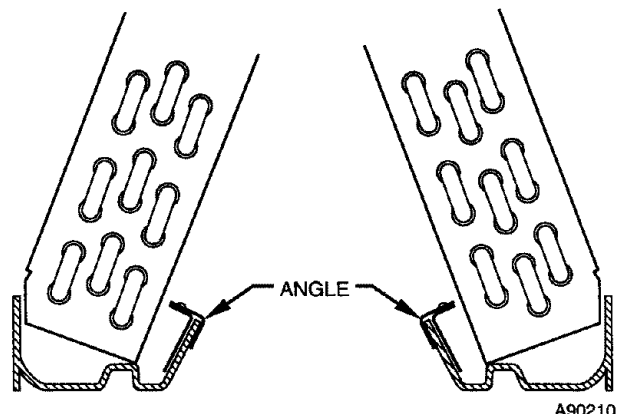

Fig. 2—Position of Angles on A-Coil

INSTALLATION- A-COIL UNITS ONLY

1. Remove all panels and expose blower and coil areas.
2. Remove any shipping clips securing coil.
3. Remove complete coil/drain pan assembly.
4. Remove and discard horizontal drain pan from coil assembly.
5. Drill four 1/4-in. holes (2 on each side) in fan coil casing at dimples provided. (See Fig. 1.)
6. Secure coil brackets (provided in kit) to casing sides. (See Fig. 1.)
7. Install support strap (provided in kit) across front of unit as follows:
 - a. Position flange on each end of strap between coil bracket and casing insulation. (See Fig. 1.)
 - b. Secure support strap ends to coil brackets. (See Fig. 1.)
8. Remove and discard 4 clips (on corners of coil) securing coil assembly to rails for upflow applications.
9. Remove and discard factory-shipped air seal and drain tube assembly. Install 1-piece sheet metal air seal assembly provided with kit.
10. Tilt coil assembly back and slide angles (provided in kit) over each inside wall of condensate pan. Pop-riveted flange of angles should extend toward coil. (See Fig. 2.)
11. With fan coil in downflow position, slide coil assembly into unit. (See Fig. 3.)
12. Reinstall all panels. Align holes in panels with tubing and condensate connections. Casing was designed to allow 180 degree rotation of coil access panel and fitting panel.
13. Install 2 plugs that have been provided onto doors to seal unit.

INSTALLATION- SLOPE COIL UNITS ONLY

1. Remove all panels and expose blower and coil areas.
2. Remove screw securing coil assembly to right side flange. Remove complete coil/drain pan assembly.
3. Drill two 1/4-in. holes in right side of casing at dimples provided (unit in upflow position).
4. Place fan coil unit in downflow position.
5. Secure coil bracket to left side of casing with 2 screws provided. (See Fig. 4.)
 - a. Remove top coil bracket from coil (2 screws).
 - b. Align holes in gasket with holes in top coil bracket.
 - c. Remove only half of the backing from the gasket.
 - d. Apply exposed half of foam gasket to under side of top coil bracket. (See Fig. 5.)
 - e. Remove remaining piece of backing from gasket and press gasket into place.
 - f. Replace top bracket onto coil. The 2 screws must engage the lanced holes.

6. Install remaining coil baffle at coil end opposite the coil headers. (See Fig. 6.)

- a. Slide the longer flange of baffle between tube sheet and end of condensate pan. Be sure notch in baffle is fully seated below notch in tube sheet.

NOTE: The TXV sensing bulb must be insulated on slope coils in horizontal right and downflow applications. Failure to insulate bulb will result in performance loss.

7. Insulate TXV sensing bulb with cork tape or other permanent insulating material.

8. Invert coil assembly and slide it into unit with drain pan to left side of fan coil. Secure coil assembly with screws. (See Fig. 3.)

9. Reinstall fitting panel, blower panel, and coil access panel. Align holes in panels with tubing and condensate connections.

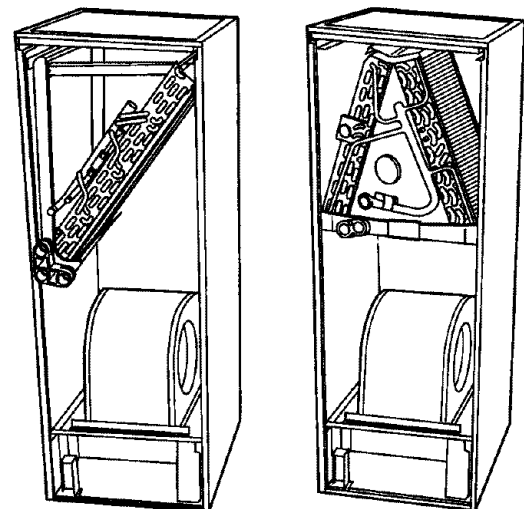

→ Fig. 3—Completed Downflow Conversion

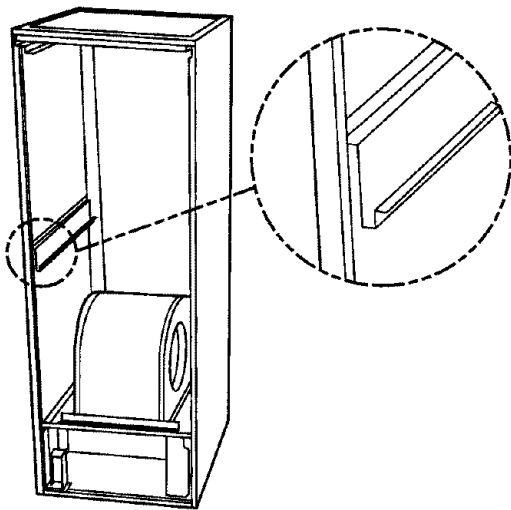

A98438

SLOPE COIL
 → Fig. 4—Downflow Slope Coil Bracket

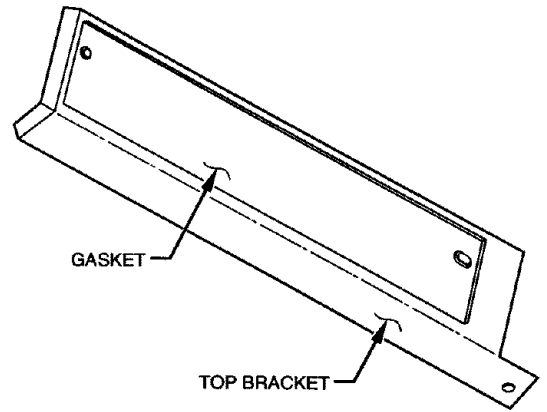

A98439

→ Fig. 5—Top Coil Bracket Gasket
 For Slope Coil Only

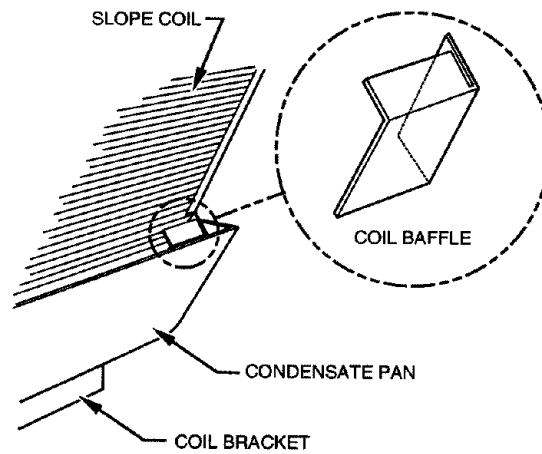

A98440

→ Fig. 6—Coil Baffle Location
 (At End Opposite Coil Header)