

# GAS WALL OVEN INSTALLATION INSTRUCTIONS

**INSTALLATION AND SERVICE MUST BE PERFORMED BY A QUALIFIED INSTALLER.**

**IMPORTANT: SAVE FOR LOCAL ELECTRICAL INSPECTOR'S USE. READ AND SAVE THESE INSTRUCTIONS FOR FUTURE REFERENCE.**

**! WARNING** If the information in this manual is not followed exactly, a fire or explosion may result causing property damage, personal injury or death.

**FOR YOUR SAFETY:**

- Do not store or use gasoline or other flammable vapors and liquids in the vicinity of this or any other appliance.
- **WHAT TO DO IF YOU SMELL GAS:**
  - Do not try to light any appliance.
  - Do not touch any electrical switch; do not use any phone in your building.
  - Immediately call your gas supplier from a neighbor's phone. Follow the gas supplier's instructions.
  - If you cannot reach your gas supplier, call the fire department.
- Installation and service must be performed by a qualified installer, service agency or the gas supplier.

**Additional Safeguards**

- Do not install wall oven beneath the work counter.
- The oven vent should not be located under 36" from the floor.

**Allow at least 21-1/4" front clearance for complete door opening.**

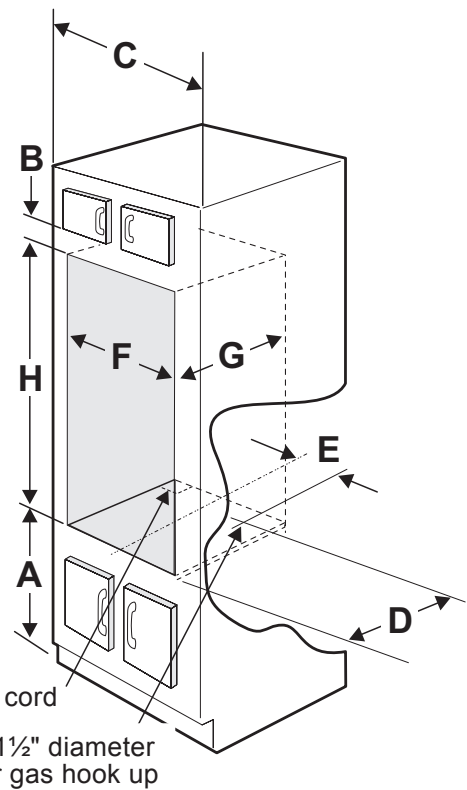
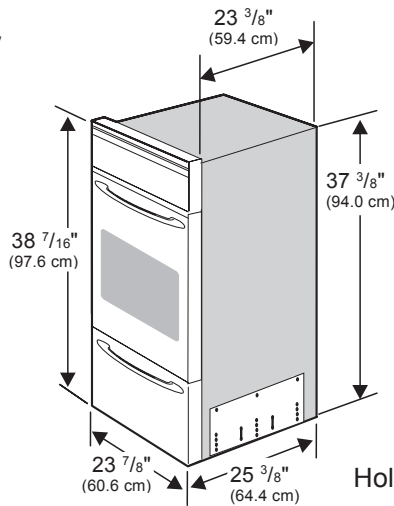

**Figure 1**

Cabinet dimensions					Cut-out dimensions		
A	B	C	D	E	F	G	H
10" Min (25.4 cm Min.)	1 1/2" Min. (3.8 cm Min.)	24" Min. (61 cm Min.)	20" (50.8 cm)	7 5/8" (19.4 cm)	22" (55.9 cm)	23 1/2" (59.7 cm)	37 1/2" Min. (95.3 Min)
27 1/2" Max. (69.9 cm Max.)							38" Max. (96.5 Max.)

# GAS WALL OVEN INSTALLATION INSTRUCTIONS

## Important Notes to the Installer

1. Read all instructions contained in these installation instructions before installing the appliance.
2. Remove all packing material and literature from the oven and broiler compartments before connecting gas and electric supply.
3. Observe all governing codes and ordinances.
4. Be sure to leave these instructions with the consumer.
5. For operation at 2000 ft. elevations above sea level, appliance rating shall be reduced by 4 percent for each additional 1000 ft.

## Important Note to the Consumer

Keep these instructions with your Use and Care Guide for future reference.  
Save these instructions for local inspectors.

# IMPORTANT SAFETY INSTRUCTIONS

### **⚠ CAUTION** POWER FAILURE

**Do not attempt to operate the oven in the event of a power failure. If power failure should occur during operation, turn the oven control to the OFF position. Failure to turn the oven control off will result in oven operation upon resumption of power to the unit.**

Installation of these appliances must conform with local codes or, in the absence of local codes, with the National Fuel Gas Code ANSI Z223.1—latest edition.

These appliances have been design certified by CSA Group. As with any appliance using gas and generating heat, there are certain safety precautions you should follow. You will find them in the Use and Care Guide, read it carefully.

- **Be sure your wall oven is installed and grounded properly by a qualified installer or service technician.**
- **These wall ovens must be electrically grounded in accordance with local codes or, in their absence, with the National Electrical Code ANSI/NFPA No. 70—latest edition. See grounding instructions farther in this manual.**

- **The installation of appliances designed for manufactured (mobile) home installation must conform with Manufactured Home Construction and Safety Standard Title 24CFR, Part 3280 [Formerly the Federal Standard for Mobile Home Construction and Safety, Title 24, HUD, (Part 280)] or when such standard is not applicable the Standard for Manufactured Home Installation 1982 (Manufactured Home Sites, Communities and Set-Ups), ANSI Z225.1/NFPA 501-A—latest edition, or with local codes.**

**⚠ CAUTION** Do not store items or food of interest to children in the cabinets above the appliance. Children could be seriously burned or injured if they climb on the appliance to reach these items.

- **Do not store or use gasoline or other flammable vapors and liquids near this or any other appliance.** Explosions or fires could result.
- Be certain all packing materials are removed from the unit before operating, to prevent fire or smoke damage should the packing material ignite.
- Do not leave children alone in the kitchen when the appliance is in use. They should not be allowed to sit or stand on any part of the appliance, as injury or burns could result. Keep children from touching the oven door or glass window when the appliance is operating, as the door or window could get hot enough to cause serious burns.
- Remove broiler tray and other utensils from oven before using the self-clean cycle (if equipped).
- Do not use the oven as a store space. This creates a potentially hazardous situation.
- The appliance requires fresh air for proper burner combustion. Do not obstruct the flow combustion air at the oven vent or around the base or beneath the lower front panel of the appliance. Avoid touching the oven openings or nearby surfaces, as they may become hot.
- Remember, your oven is not designed to heat your kitchen. Such abuse could result in fire and/or damage to the unit and will void your warranty.

# GAS WALL OVEN INSTALLATION INSTRUCTIONS

## 1. Carpentry

Refer to Figure 1 for the dimensions applicable to your appliance, and the space necessary to receive the oven. Corners must be square.

Floor cabinet must be able to support 150 pounds and must be flush with bottom of opening.

Oven support surface must be solid plywood or similar material. MDF (medium-density fibreboard), particle board, or laminated woods are not to be used as base support.

## 2. Connect Electricity to Gas Wall Oven

**For personal safety, these appliances must be properly grounded.**

**⚠ WARNING** This appliance is equipped with a three-prong grounding plug for your protection against shock hazard and must be plugged directly into a properly grounded receptacle. Do not cut or remove grounding prong from this plug.

120 volt, 60 Hertz, properly grounded dedicated circuit protected by a 15 amp circuit breaker or time delay fuse.

**Do not use an extension cord with this range.**

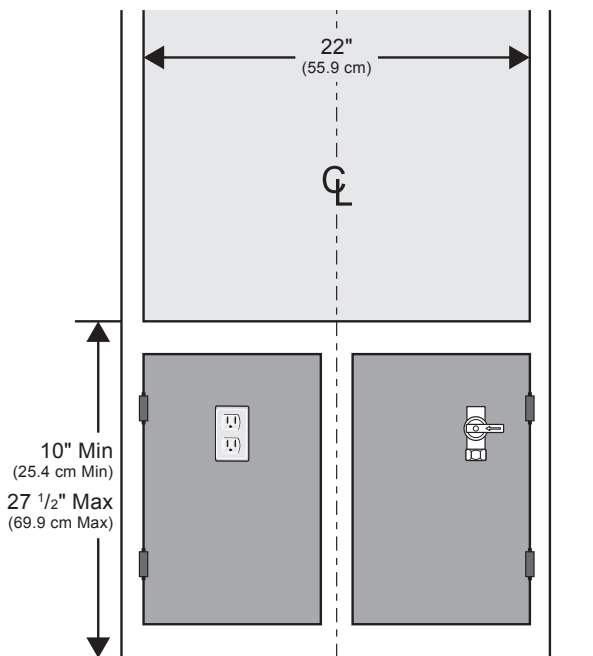

Figure 2

The wall receptacle should be located in the cabinet beneath the installation cutout. The receptacle should be easily accessible for service and removal of power from appliance (see Figure 2)

The wall receptacle and circuit should be checked by a qualified electrician to make sure the receptacle is properly grounded.

### Preferred Method

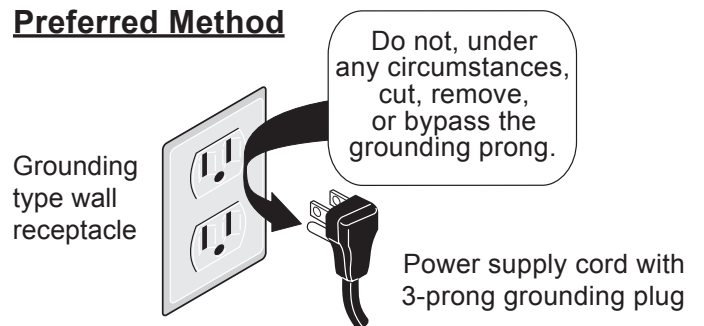

Figure 3

Where a standard 2-prong wall receptacle is installed, it is the personal responsibility and obligation of the consumer to have it replaced by a properly grounded 3-prong wall receptacle.

**Do not, under any circumstances, cut or remove the third (ground) prong from the power cord.**

If an external electrical source is used, the appliance, when installed, must be electrically grounded in accordance with local codes or in their absence of local codes with the National Electric Code ANSI/NFPA No. 70-1987 or latest edition.

Check all code rules and regulations for connecting the wall oven to be certain the installation conforms with all local, municipal and state codes as well as local utility regulations.

Failure to comply with the above could result in a **serious shock hazard**.

**Note:** All hook-ups and adjustments shall be performed by qualified technicians.

**⚠ CAUTION** Disconnect electrical supply cord from wall receptacle before servicing wall oven.

# GAS WALL OVEN INSTALLATION INSTRUCTIONS

## 3. Alternate construction

Installation Instructions for installing a 1½ cavity oven into an existing 2 cavity opening with dimensions 42-1/8" height by 22 ½" Width.

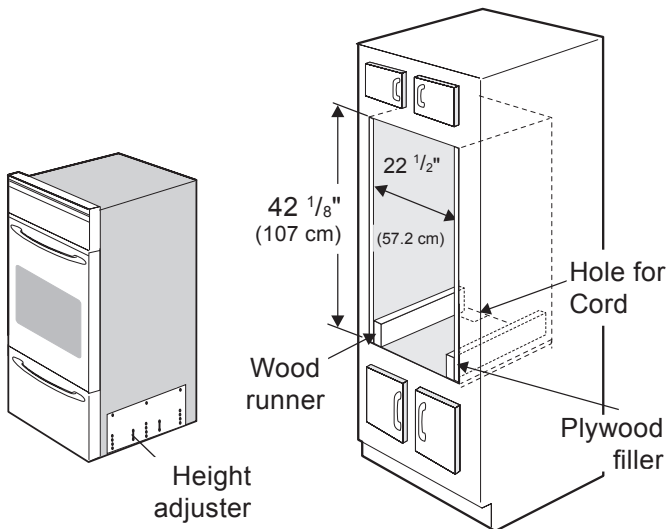

Figure 4

- If width opening is too wide to secure unit to cabinet with mounting screws, add plywood filler strips.
- If height opening is at 42-1/8", lower height adjuster 1" (see section 4) and secure two 2" X 4" X 22" wood runners on each side at bottom of opening (see Figure 4).
- The decorative lower trim (not shown) can be installed to hide the gap under the unit. It should overlap by ¼" the front of the cabinet at bottom of cutout (see step 2 of section 5).

## 4. Adjusting Oven Height

Remove and lay aside the lower vent decorative trim that is taped to the side or to the top of the oven. The decorative trim will be fastened to the lower front of the oven after it has been installed in the cabinet.

There is a 1 ½" height adjustment on models with extension panel (see Figure 5). With this adjustment and a ½" trim overhang, a unit can be installed in existing openings 37 ½" to 39" high.

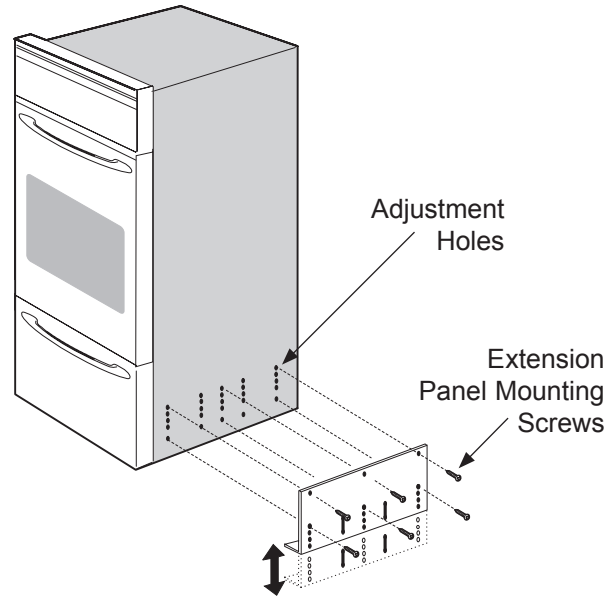

Figure 5

# GAS WALL OVEN INSTALLATION INSTRUCTIONS

## To adjust oven height:

1. Lay oven on its back (see Figure 6).
2. Remove the 3 screws that fasten the side extension panel to the bottom sides of the oven.
3. Move each panel down to the position that increases the oven height to fit your opening. Each position changes oven height approximately  $\frac{1}{2}$ ".
4. Line up the appropriate holes in the side extension panels and sides of the oven. Put the 3 screws back.
5. Proceed with oven installation. Return to upright position.

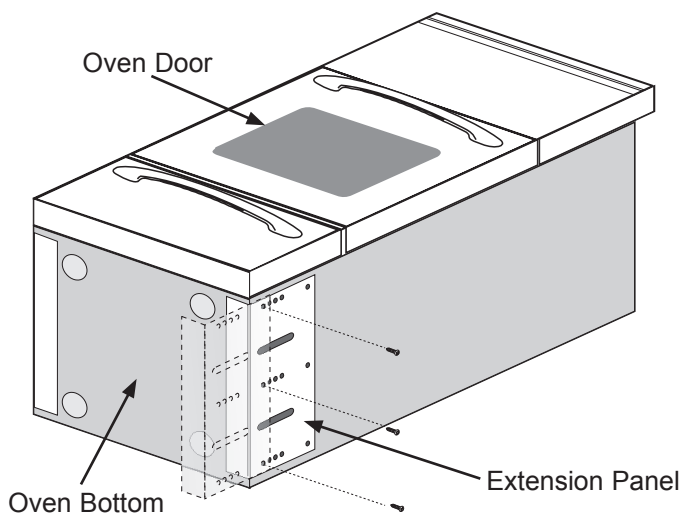

Figure 6

## 5. Cabinet Installation

Insert appliance into cutout. Use the 2 mounting screws provided to fasten the front frame of the appliance to the cabinet (steps 1 below). Keep the 6 decorative screws to fix the decorative trim to the cabinet (step 2 below). The mounting holes in the front frame of appliance may be used as a template to locate the appliance mounting screw holes on the cabinet.

To fasten the appliance to the cabinet (see Figure 7):

1. Use 2 mounting screws supplied to secure the appliance to the cabinetry. 2 holes are located under the center vent trim on each side.
2. Install the decorative trim panel to appliance bottom using the 6 supplied screws. Four screws are installed along the front of the panel. Two screws are installed at the upper corners of the panel.

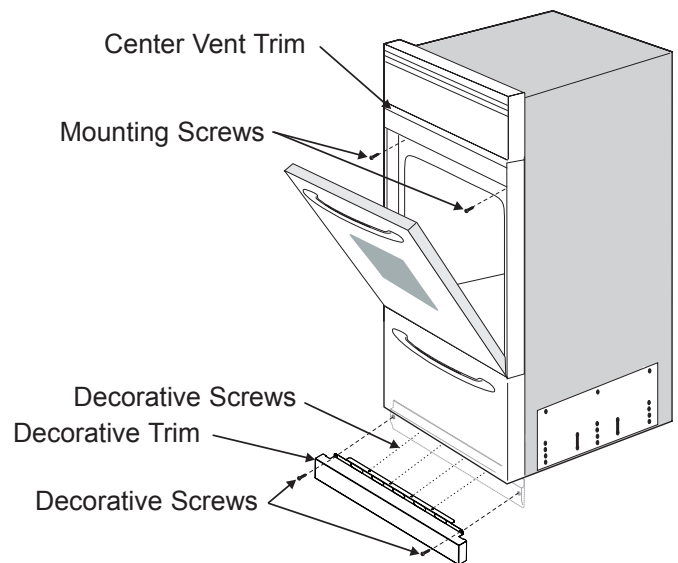

Figure 7

# GAS WALL OVEN INSTALLATION INSTRUCTIONS

## 6. Provide an Adequate Gas Supply

**Important:** Read these instructions carefully before connecting this unit to a gas supply.

The units covered in these instructions are designed to operate on natural gas at 4" of manifold pressure or on LP gas at 10" of manifold pressure.

A convertible pressure regulator is connected in series with the manifold of the wall oven unit and must remain in series with the supply line, regardless of which type of gas is being used.

**For proper operation,** the maximum inlet pressure to the regulator must not exceed 14" of water column (W.C.) pressure.

To check the regulator, the inlet pressure must be at least 1" (or 3.4 kPa) greater than the regulator pressure setting. If the regulator is set for 4", the inlet pressure must be at least 5". If the regulator is set for 10", the inlet pressure must be at least 11".

A manual shut-off valve must be installed on the gas supply line external to the unit and where it can be easily reached for the purpose of turning the gas to the unit on and off. The recommended location for the shut-off valve is in the cabinet beneath the installation cutout (see Figure 8).

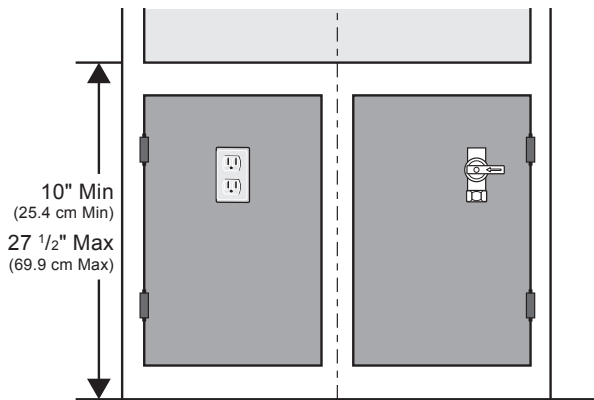

Figure 8

The gas supply line to the unit should be 1/2" (1.3 cm) or 3/4" (1.9 cm) pipe.

Close all openings in the cabinet cavity that encloses this unit. All openings around gas service outlets must be closed at the time of installation.

## 7. Connection to Gas (see Figure 9)

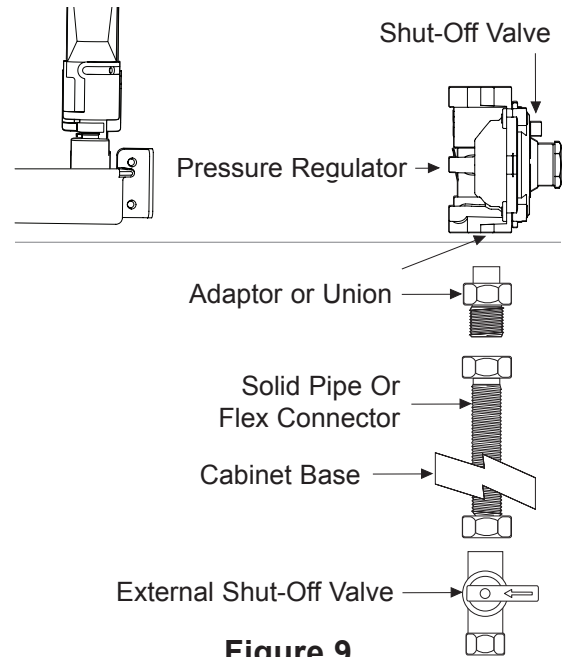

Figure 9

### BEFORE CONNECTING THE UNIT

Remove all packing material and literature from wall oven before connecting gas and electrical supply to the appliance.

If applicable, remove broiler or storage drawer by pulling drawer out to stops. Lift drawer front to clear stops and pull out.

The fuel regulator on this appliance has a built-in shut-off valve. Make sure the valve is UP in the OPEN position (see Figure 10).

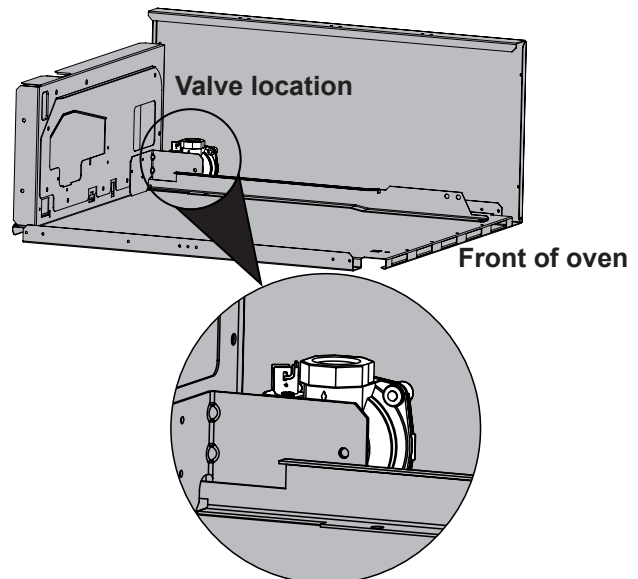

Figure 10a

# GAS WALL OVEN INSTALLATION INSTRUCTIONS

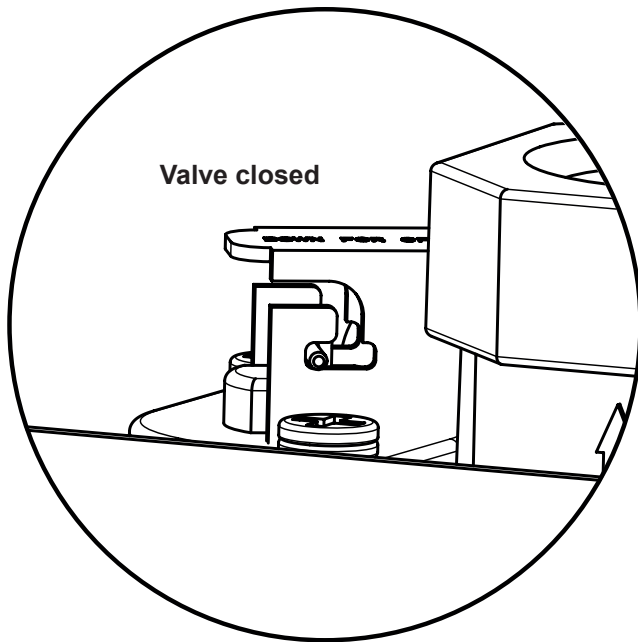

Figure 10b

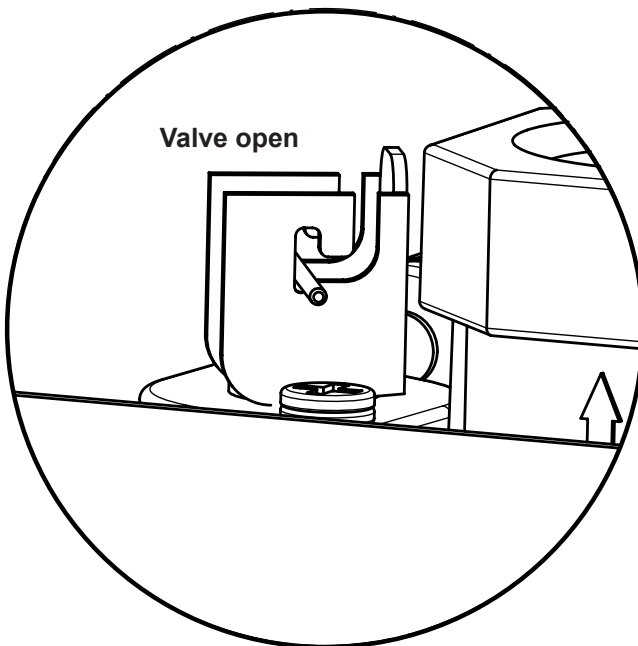

Figure 10c

**Check for leaks.** After connecting gas, check system for leaks with a manometer. If a manometer is not available shut all pilots off (if present), turn on the gas supply to the unit and use a liquid leak detector at all joints and connections.

**Tighten all connections** if necessary to prevent gas leakage in the wall oven or supply line.

**IMPORTANT:** A pipe joint sealant resistant to the action of LP Gas must be used on all pipe connections.

**CAUTION** Do not use a flame to check for leaks from gas connections. Checking for leaks with a flame may result in a fire or explosion.

**Disconnect the oven and its individual shutoff valve** from the gas supply piping system during any pressure test greater than ½ psig.

**Isolate the wall oven from the gas supply piping system** by closing its individual manual shutoff valve during any pressure testing of the gas supply piping system at test pressures equal to or less than ½ psig.

## 8. LP/Propane Gas Conversion

### A. Pressure Regulator Conversion

**Note:** Do not remove the Pressure Regulator.

**Convert the Pressure Regulator for use with LP Gas** (see Figure 11).

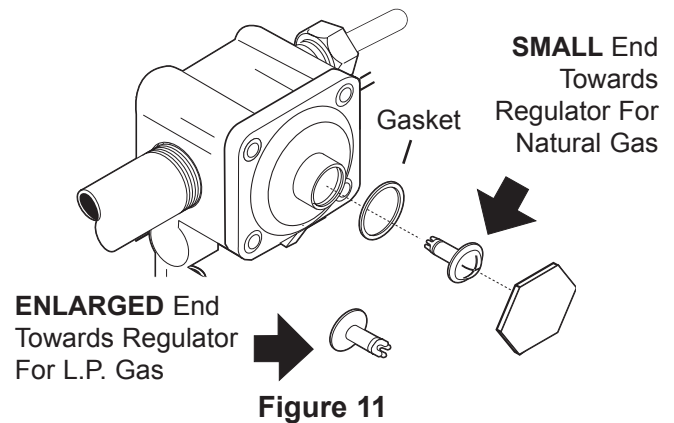

Figure 11

If applicable, remove broiler or storage drawer by pulling drawer out to stops. Lift drawer front to clear stops and pull out.

Locate pressure regulator on lower back wall and convert as shown in Figure 10.

1. Remove the cap from the pressure regulator.
2. Remove the plunger.
3. Turn the plunger upside down with the enlarged end **TOWARDS** regulator.
4. Replace the plunger inside the regulator. The letters LP or 10" W.C. should be visible on the exposed end of the plunger.
5. Replace the cap on the pressure regulator.

**NOTE:** The type of gas pressure the regulator is set for is indicated on the top of the plunger.

# GAS WALL OVEN INSTALLATION INSTRUCTIONS

## B. Adjust Oven Burner Orifice (see Figure 12)

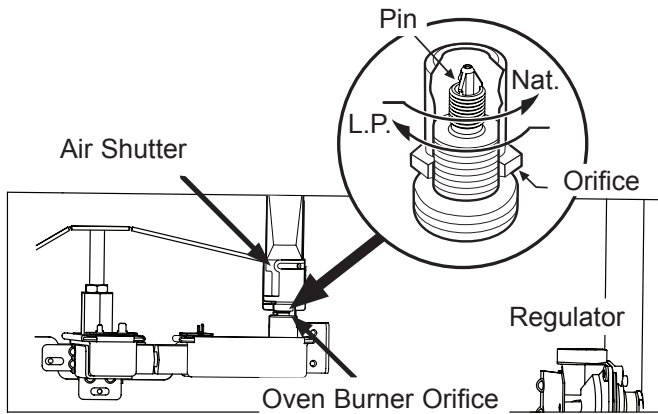

**Figure 12**

Using a ½" wrench, turn down the adjustable orifice which injects gas into the oven burner. Turn orifice approximately 2½ turns until snug against the LP metering pin. Do not overtighten.

## C. Adjust Broiler Burner Orifice (Self-Cleaning Models Only) (see figure 13)

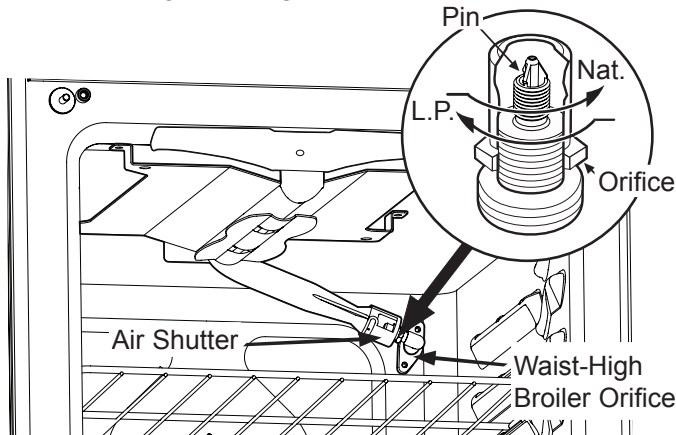

**Figure 13**

Using a ½" wrench, turn down the adjustable orifice which injects gas into the oven burner. Turn orifice approximately 2½ turns until snug against the LP metering pin. Do not overtighten.

## 9. Natural Gas Conversion

### Convert the Pressure Regulator for use with Natural Gas (see Figure 10)

- Remove the cap from the pressure regulator.
- Remove the plunger.
- Turn the plunger around so that the small end is **TOWARDS** the regulator.

D. Replace the plunger inside the regulator. The letters NAT or 4" W.C. should be visible on the exposed end of the plunger.

E. Replace the cap on the pressure regulator.

F. Turn orifice approximately 2½ turns counter-clockwise. This will move the spud away from the pin.

G. Apply gas, adjust pilots (if equipped) and burner air shutter for proper flame.

H. There should be 4" WC pressure in the manifold after conversion for proper operation on Natural Gas.

## 10. Adjustments

### Oven/Broiler Flame Adjustment

The air shutter adjustment is located on the venturi tube, which sets on the orifice of the valve, and is locked in place with a Phillips head screw. If the air shutter needs adjusting, loosen the screw and rotate the shutter to allow more or less air to the burner tube (see Figure 14).

For Natural Gas, the air shutter should be approxi-

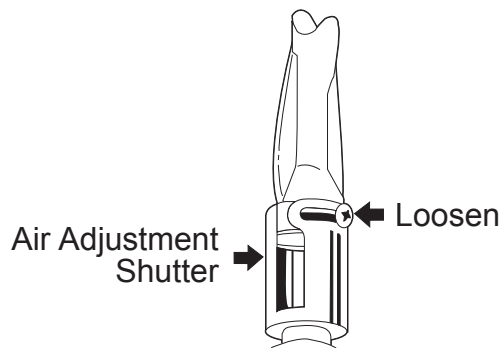

**Figure 14**

mately half open. For LP Gas, the air shutter nearly full open.

Too much air will cause the flame to lift away from the burner. Too little air will cause the flame to turn yellow at the outer edges and soot to form.

Remember, the oven will be shipped from the factory set for Natural Gas, unless otherwise stated. If connecting to LP gas, be sure to follow procedure under "Conversion" to change the regulator and burner orifice to the LP setting.

Observe the oven burner flame to determine if it is



# GAS WALL OVEN INSTALLATION INSTRUCTIONS

right. It should be steady with a blue cone approximately 1" long and should not extend out over the edges of baffle. For LP Gas, this will most likely occur when the air adjustment shutter is completely open (see Figure 15).

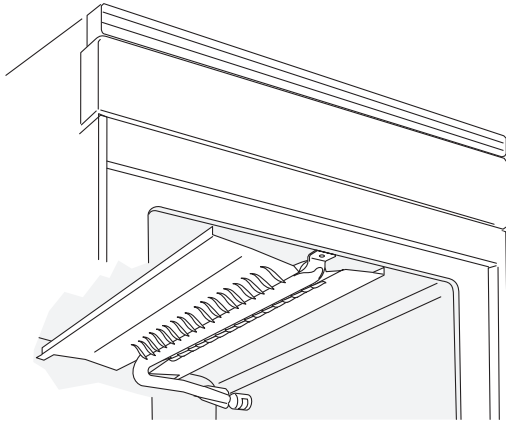

**Figure 15**

Turn Oven Temperature to 300°F and allow oven burner to cycle on and off.

To replace broiler or storage drawer, reverse steps taken for removal (see the Use and Care Guide for complete instructions). Replace oven racks.

## 11. Check Operation

Refer to the Use and Care Guide packaged with the wall oven for operating instructions and for care and cleaning of your appliance.

Do not touch the oven burners. They may be hot enough to cause burns.

### 1. Check the Igniters (some models)

Operation of electric igniters should be checked after oven and supply line connectors have been carefully checked for leaks and oven has been connected to electric power.

### 2. Oven Igniter System

Close the door and turn the Oven Temperature to 300°F. In approximately 60 seconds, the burner should ignite and stay on until oven reaches 300°F. Burner should then cycle on and off to maintain an average temperature of approximately 300°F.

## When All Hookups are Complete

Make sure all controls and programmable timer are left in the OFF position.

Reset all controls to the "OFF" position after using a programmable timing operation.

## Model and Serial Number Location

The serial plate is located on the left side inner trim of the oven.

When ordering parts for or making inquiries about your wall oven, always be sure to include the model and serial numbers and a lot number or letter from the serial plate of your appliance.

Your serial plate also tells you the rating of the burners, the type of fuel and the pressure the wall oven was adjusted for when it left the factory.

## **⚠ WARNING**

- **Stepping, leaning or sitting on the oven door or drawer can result in serious injuries and also cause damage to the appliance.**
- **Be sure to keep appliance clear of combustible materials, gasoline and other flammable vapors and liquids.**

## Before You Call for Service

Read the Avoid Service Checklist and operating and cleaning instructions in your Use and Care Guide.

Check to make sure the house fuse or circuit breaker for your wall oven is not blown or open.

## Care, Cleaning and Maintenance for Wall Ovens

If removing the wall oven is necessary for cleaning or maintenance, shut off gas supply. Disconnect the gas and electric supply. Remove the installation screws from front frame and lower trim. Pull out only as far as necessary to disconnect the electric supply line. After disconnecting the gas and electric supply, finish removing the unit for servicing and cleaning. Reinstall in reverse order and make sure that appliance is level; check gas connection for leaks.