

**SEARS
OWNER'S
MANUAL**

**MODEL NO.
247.795890**

**Caution:
Read and Follow
All Safety Rules
and Instructions
Before Operating
This Equipment**

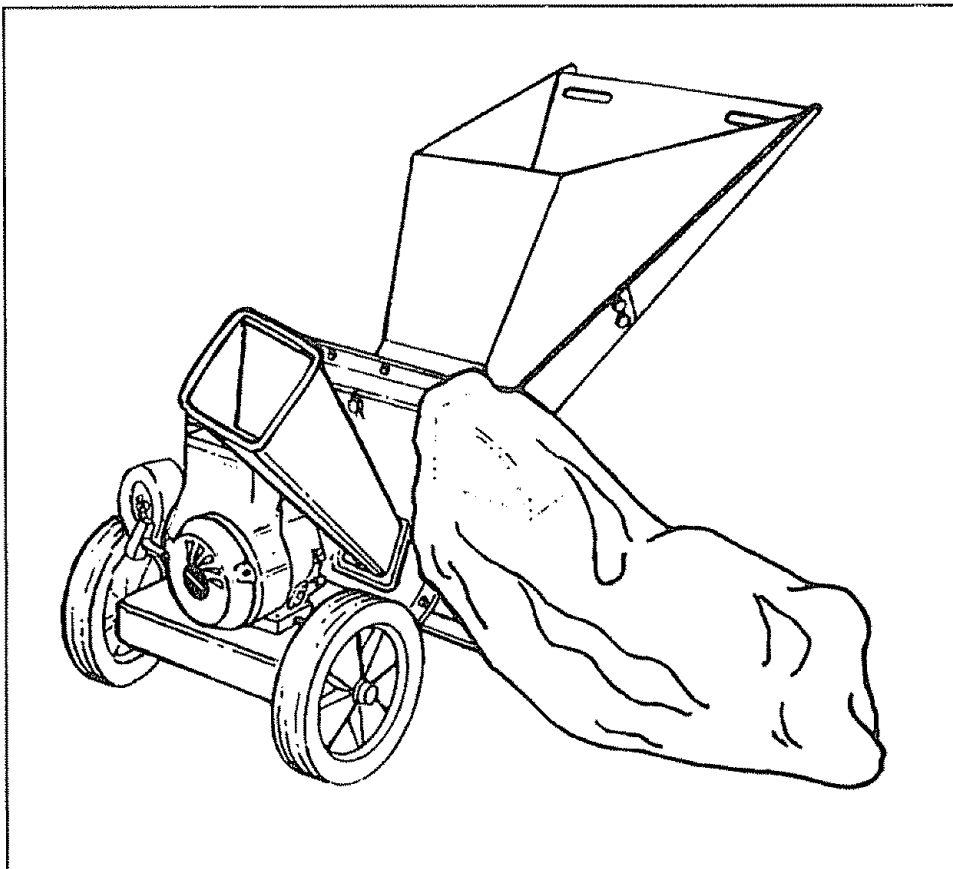

CRAFTSMAN®

**9 HORSEPOWER
3 CUTTING STAGE
MULCHING AND BAGGING
CHIPPER-SHREDDER**

**Assembly
Operation
Customer Responsibilities
Service and Adjustment
Repair Parts**

SEARS, ROEBUCK AND CO., Hoffman Estates, IL 60179 U.S.A.

SAFETY RULES



WARNING: TO REDUCE THE POTENTIAL FOR ANY INJURY, COMPLY WITH THE FOLLOWING SAFETY INSTRUCTIONS. FAILURE TO COMPLY WITH THE INSTRUCTIONS MAY RESULT IN PERSONAL INJURY.

TRAINING

- Read this owner's manual carefully in its entirety before attempting to assemble or operate this machine. Be completely familiar with the controls and the proper use of this machine before operating it. Keep this manual in a safe place for future and regular reference and for ordering replacement parts.
- Children must never be allowed to operate this equipment.
- No one should operate this unit while intoxicated or while taking medication that impairs the senses or reactions.
- This equipment should never be operated in the vicinity of children, pets or other persons.
- Never run your machine in an enclosed area as the exhaust from the engine contains carbon monoxide, which is an odorless, tasteless and deadly poisonous gas.
- Never place your hands or any part of your body or clothing inside the feeding chamber, discharge chute, or near any moving part while the machine or engine is running.
- If it is necessary for any reason to inspect or repair the feeding chamber or any part of the machine where a moving part can come in contact with your body or clothing, stop the machine, allow it to cool, disconnect the spark plug wire from the spark plug and move it away from the spark plug before attempting such inspection or repair.

PREPARATION

- Wear safety glasses provided with your unit while operating the chipper-shredder to prevent injury from any material which may be ejected out of the openings.
- Wear proper apparel. Avoid wearing loose fitting clothing. Wear gloves when handling material.
- **HANDLE GASOLINE WITH CARE** as it is an extremely flammable fuel.
- Check the fuel before starting the engine. Do not fill the fuel tank indoors, while the engine is running, or while the engine is still hot. Turn the unit off and let the engine cool before refueling.
- Fuel your chipper-shredder in a clean area. Do not smoke while refueling.
- Fuel tank cap must be secure at all times except during refueling.
- Avoid spilling gasoline or oil. Wipe the unit clean of any spilled fuel or oil.
- Store fuel and oil in approved containers, away from heat or open flame, and out of reach of children.
- This machine should be operated only upon a level surface.
- Assure that all screws, nuts and bolts and other fasteners are properly secured.

OPERATION

- When feeding shreddable material into this equipment, be extremely careful that pieces of metal, rocks, bottles, cans or other foreign objects are not included. Personal injury or damage to the machine could result.

- If the cutting mechanism strikes any foreign object or if your machine should start making an unusual noise or vibration, immediately stop the engine, disconnect the spark plug wire from the spark plug and move it away from the spark plug. Allow the machine to stop and take the following steps:
 - Inspect for damage.
 - Replace or repair any damaged parts.
 - Check for any loose parts and tighten to assure continued safe operation.
- The engine must be kept clean of debris and other accumulations.
- Do not allow an accumulation of processed material to build up in the discharge area as this will prevent proper discharge and can result in kick-back from feed opening.
- Never place your hands or any other part of your body or clothing inside the feeding chamber, discharge chute or near any moving part while the engine is running.
- Keep all guards and deflectors in place and in good working condition to assure continued safe operation.
- Always stand clear of the discharge area when operating this machine.
- Keep your face and body back from the feed opening to avoid accidental bounce back of any material.
- Do not over-reach. Keep proper balance and footing at all times.
- The engine governor settings on your machine must not be altered, changed, or tampered with. The governor controls the maximum safe operating speeds and protects the engine and all moving parts from damage caused by overspeed.
- Do not transport machine while engine is running.
- Do not operate engine if air cleaner or cover directly over carburetor air intake is removed, except for adjustment. Removal of such parts could create a fire hazard.

MAINTENANCE AND STORAGE

- When this equipment is stopped for servicing, inspection, storage or to change an accessory, make sure the spark plug wire is disconnected from the spark plug and moved away from the spark plug. The machine should be allowed to cool down before making such inspection, adjustments, service, etc. Maintain your machine with care and keep it clean for the best and continued safe operation.
- Do not use flammable solutions to clean the air filter.
- When not in use, your machine should be stored out of the reach of children. Keep where gasoline fumes will not reach an open flame or spark. For long periods of storage, refer to the "Storage" section of this manual.



LOOK FOR THIS SYMBOL TO POINT OUT IMPORTANT SAFETY PRECAUTIONS. IT MEANS—ATTENTION!!! BECOME ALERT!!! YOUR SAFETY IS INVOLVED.

CONGRATULATIONS on your purchase of a Sears Craftsman Chipper-Shredder. It has been designed, engineered and manufactured to give you the best possible dependability and performance.

Should you experience any problem you cannot easily remedy, please contact your nearest Sears Service Center/Department in the United States. We have competent, well-trained technicians and the proper tools to service or repair this unit.

Please read and retain this manual. The instructions will enable you to assemble and maintain your chipper-shredder properly. Always observe the "SAFETY RULES."

MODEL NUMBER <u>247.795890</u>
SERIAL NUMBER _____
DATE OF PURCHASE _____
THE MODEL AND SERIAL NUMBERS WILL BE FOUND ON A LABEL ATTACHED TO THE FRAME OF THE CHIPPER-SHREDDER.
YOU SHOULD RECORD BOTH SERIAL NUMBER AND DATE OF PURCHASE AND KEEP IN A SAFE PLACE FOR FUTURE REFERENCE.

CUSTOMER RESPONSIBILITIES

- Read and observe the safety rules.
- Follow a regular schedule in maintaining, caring for and using your chipper-shredder.
- Follow the instructions under "Customer Responsibilities" and "Storage" sections of this Owner's Manual.

PRODUCT SPECIFICATIONS

Horsepower:	9.0
Engine Oil: API Classification SG or SH	SAE 30 (26 ounces)
Fuel Capacity:	1 Gallon (Unleaded)
Spark Plug (Gap .030 in.):	Champion J19LM (or Equivalent)
Tire Pressure:	35-40 p.s.i.

MAINTENANCE AGREEMENT

A Sears Maintenance Agreement is available on this product. Contact your nearest Sears store for details.

WARNING: This unit is equipped with an internal combustion engine and should not be used on or near any unimproved forest-covered, brush-covered or grass-covered land unless the engine's exhaust system is equipped with a spark arrester meeting applicable local or state laws (if any). If a spark arrester is used, it should be maintained in effective working order by the operator.

In the State of California the above is required by law (Section 4442 of the California Public Resources Code). Other states may have similar laws. Federal laws apply on federal lands. A spark arrester for the muffler is available through your nearest Sears Authorized Service Center (See the REPAIR PARTS section of this manual.)

WARRANTY

FULL ONE YEAR WARRANTY ON CRAFTSMAN GAS CHIPPER-SHREDDER

For one year from the date of purchase, when this Craftsman chipper-shredder is maintained, lubricated, and tuned up according to the operating and maintenance instructions in the operator's manual, Sears will repair, free of charge, any defect in material or workmanship.

This warranty excludes the blades, chipper blades, flails, air cleaners, spark plugs, catcher bags and tires, which are expendable parts and become worn during normal use.

If this chipper-shredder is used for commercial or rental purposes, this warranty applies for only 30 days from the date of purchase.

WARRANTY SERVICE IS AVAILABLE BY CONTACTING THE NEAREST SEARS SERVICE CENTER IN THE UNITED STATES. THIS WARRANTY APPLIES ONLY WHILE THIS PRODUCT IS IN USE IN THE UNITED STATES.

This warranty gives you specific legal rights, and you may also have other rights which vary from state to state.

SEARS ROEBUCK AND CO., DEPT. 817WA, HOFFMAN ESTATES, IL 60179

TABLE OF CONTENTS

SAFETY RULES.....2	CUSTOMER RESPONSIBILITIES.....11, 12
PRODUCT SPECIFICATIONS.....3	STORAGE.....13
WARRANTY.....3	SERVICE AND ADJUSTMENT.....13-15
INDEX.....4	TROUBLE SHOOTING.....16
ACCESSORIES.....4	REPAIR PARTS—CHIPPER-SHREDDER.....17, 18
ASSEMBLY.....5-7	REPAIR PARTS—ENGINE.....19-23
OPERATION.....7-10	PARTS ORDERING/SERVICE.....BACK COVER

INDEX

<p style="text-align: center;">A</p> <p>Accessories.....4</p> <p>Adjustments:</p> <p style="padding-left: 20px;">Carburetor.....15</p> <p style="padding-left: 20px;">Engine Speed.....15</p> <p style="padding-left: 20px;">Throttle.....15</p> <p>Assembly Instructions:</p> <p style="padding-left: 20px;">Catcher Bag.....6</p> <p style="padding-left: 20px;">Chute Deflector.....6</p> <p style="padding-left: 20px;">Hopper Assembly.....6</p> <p style="padding-left: 20px;">Catcher Bag.....6, 7</p> <p style="text-align: center;">C</p> <p>Catcher Bag.....6, 7</p> <p>Controls.....7</p> <p>Customer Responsibilities.....3, 11, 12</p> <p style="text-align: center;">E</p> <p>Engine:</p> <p style="padding-left: 20px;">Maintenance.....11, 12</p> <p style="padding-left: 20px;">Starting.....10</p> <p style="padding-left: 20px;">Stopping.....8</p> <p style="padding-left: 20px;">Storage.....13</p> <p style="text-align: center;">F</p> <p>Fuel.....9</p> <p style="text-align: center;">L</p> <p>Lubrication.....11</p>	<p style="text-align: center;">M</p> <p>Maintenance:</p> <p style="padding-left: 20px;">Agreement.....3</p> <p style="padding-left: 20px;">Schedule.....11</p> <p style="padding-left: 20px;">Engine.....11, 12</p> <p style="padding-left: 20px;">Chipper-Shredder.....11</p> <p style="text-align: center;">O</p> <p>Oil.....9</p> <p>Operating Tips.....8</p> <p style="text-align: center;">R</p> <p>Repair/Replacement Parts.....17-23</p> <p>Responsibilities, Customer.....3, 11-13</p> <p style="text-align: center;">S</p> <p>Safety Rules.....2</p> <p>Sharpening.....14, 15</p> <p>Service Recommendations.....11</p> <p>Spark Plug.....12</p> <p>Specifications.....3</p> <p>Storage.....13</p> <p style="text-align: center;">T</p> <p>Table of Contents.....4</p> <p>Trouble Shooting.....16</p> <p style="text-align: center;">U</p> <p>Unclogging.....13, 14</p> <p>Unpacking.....5</p> <p style="text-align: center;">W</p> <p>Warranty.....3</p>
---	---

ACCESSORIES

These accessories were available when the chipper-shredder was purchased. They are also available at most Sears retail outlets, catalog and service centers. Most Sears stores can order repair parts for you, when you provide the model number of your chipper-shredder.

ENGINE

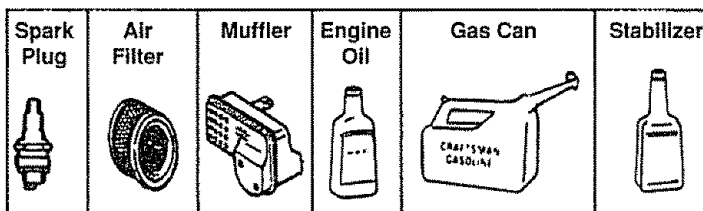

CHIPPER-SHREDDER

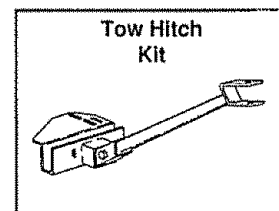

ASSEMBLY INSTRUCTIONS

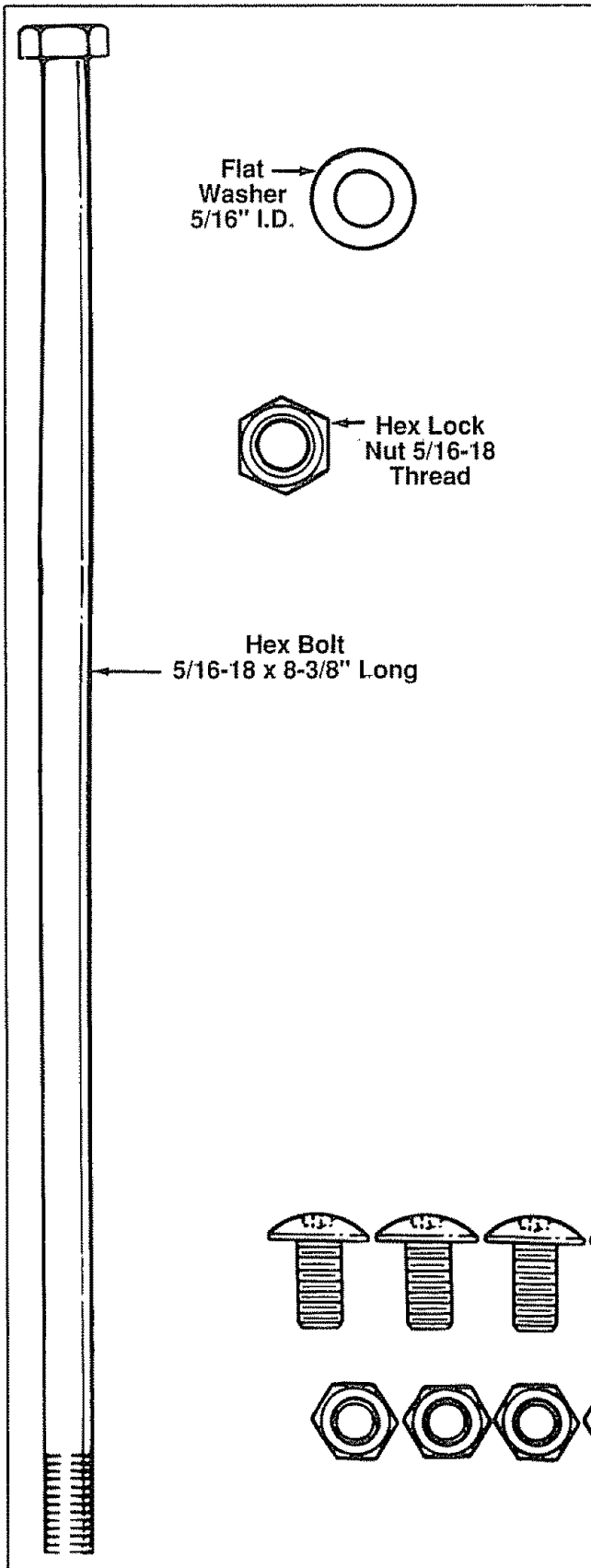

IMPORTANT: This unit is shipped WITHOUT GASOLINE or OIL in the engine. After assembly, see operation section of this manual for proper fuel and engine oil recommendations.

NOTE: To determine right and left hand sides of your chipper-shredder, stand behind and face the hopper (engine is at the front of the unit).

Your chipper-shredder has been completely assembled at the factory, except for the hopper assembly (hopper hood and upper leaf ramp section have been sub-assembled), upper guide assembly, chute deflector and the catcher bag. The hardware pack safety glasses and a bottle of oil are also included in the carton.

The hardware pack contains the parts shown in figure 1 (shown full size).

TO REMOVE CHIPPER-SHREDDER FROM CARTON

Cut the corners of the carton. Remove all packing inserts. Roll chipper-shredder out of the carton. Make certain all parts and literature have been removed before the carton is discarded.

TOOLS REQUIRED FOR ASSEMBLY

- (1) Phillips Screwdriver
- (2) 1/2" or Adjustable Wrenches
- (2) 7/16" or Adjustable Wrenches

FIGURE 1.

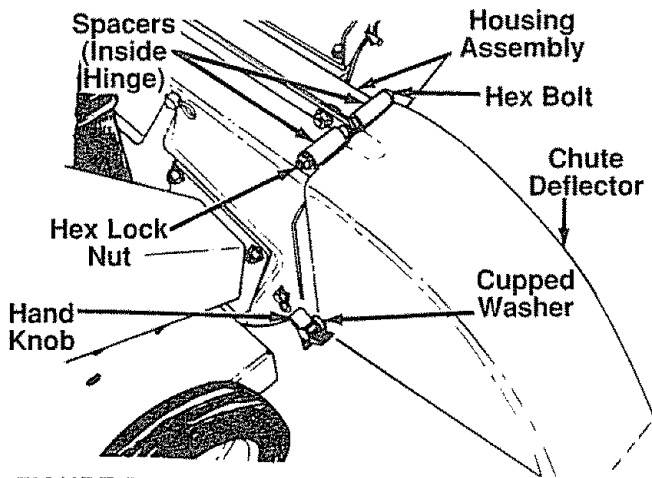

FIGURE 2.

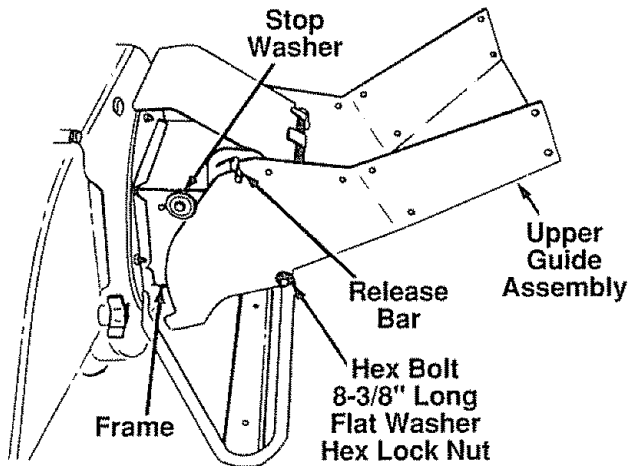

FIGURE 3.

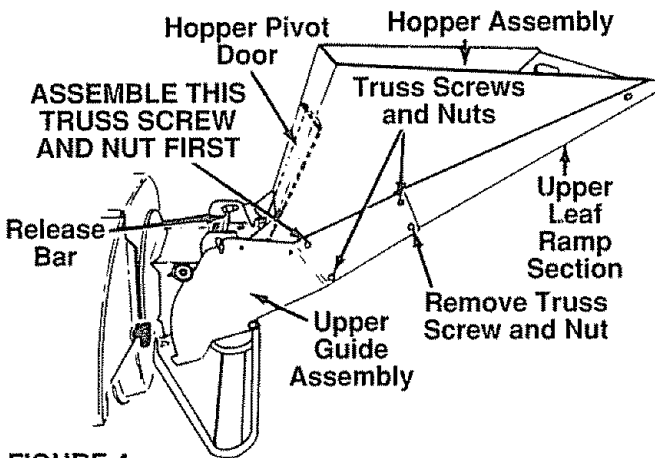

FIGURE 4.

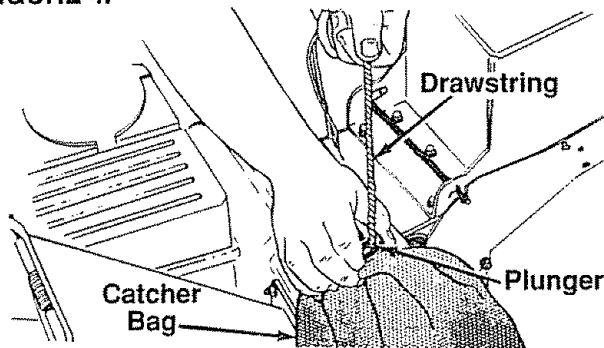

FIGURE 5.

HOW TO SET-UP YOUR CHIPPER-SHREDDER



WARNING: MAKE CERTAIN SPARK PLUG WIRE (LOCATED ON TOP OF ENGINE) IS DISCONNECTED AND MOVED AWAY FROM SPARK PLUG BEFORE ASSEMBLING THE CHIPPER-SHREDDER.

← ATTACHING THE CHUTE DEFLECTOR

- Remove the hand knobs and cupped washers from each side of the discharge opening on the left side of the chipper-shredder.
- Remove hex lock nut, two spacers and hex bolt from inside the hinge on top of the housing assembly. Do not remove one spacer from the hex bolt.
- Place the chute deflector in position on the discharge opening. Insert hex bolt and spacer through hinge on chute deflector and housing (spacer fits inside of hinge). See figure 2.
- Place second spacer over hex bolt, inside other part of hinge. Secure with hex lock nut. Tighten securely.
- Secure both sides of chute deflector to housing using hand knobs and cupped washers (cupped side of washers go against chute deflector).

← ATTACHING THE UPPER GUIDE ASSEMBLY

Place upper guide assembly in position on frame, making certain edges of the upper guide assembly are underneath stop washers, and the release bar is in the slots. See figure 3. Insert hex bolt 8-3/8" long through upper guide assembly and frame. Secure with flat washer and hex lock nut.

NOTE: Make certain upper guide assembly can pivot by pulling up on release bar and lowering upper guide assembly. If necessary, loosen hex lock nut a turn or two. Put the upper guide assembly back into the raised position.

← ATTACHING THE HOPPER ASSEMBLY

Your chipper-shredder has been shipped with the upper leaf ramp section attached to the hopper assembly. See figure 4. Attach the hopper assembly to the upper guide assembly as follows. Be certain to place heads of all truss machine screws **inside** of hopper assembly.

- Remove one truss machine screw and nut from each side of hopper assembly as shown in figure 4. **Push hopper pivot door down inside lower part of hopper** as you place hopper assembly (both pieces) **inside** upper guide assembly. Replace truss screws and nuts just removed, using the hole shown in figure 4, one on each side. Tighten finger tight only.
- Place the six truss machine screws and nuts found in hardware pack in the remaining holes of hopper assembly, alternating sides of the unit and tightening finger tight only.
- After assembling all eight screws, tighten them securely.

← ATTACHING THE CATCHER BAG

Your chipper-shredder is equipped with a catcher bag to catch the shredded material.

- To attach the bag, place the opening of the bag over the chute deflector so it completely covers the chute opening. Depress the plunger on the draw-

string, and pull on the drawstring until the bag is tight around the chute opening. Release plunger to lock it into position. See figure 5.

OPERATION

KNOW YOUR CHIPPER-SHREDDER

READ THIS OWNER'S MANUAL AND SAFETY RULES BEFORE OPERATING YOUR CHIPPER-SHREDDER. Compare the illustrations with your chipper-shredder to familiarize yourself with the location of various controls and adjustments. Save this manual for future reference.

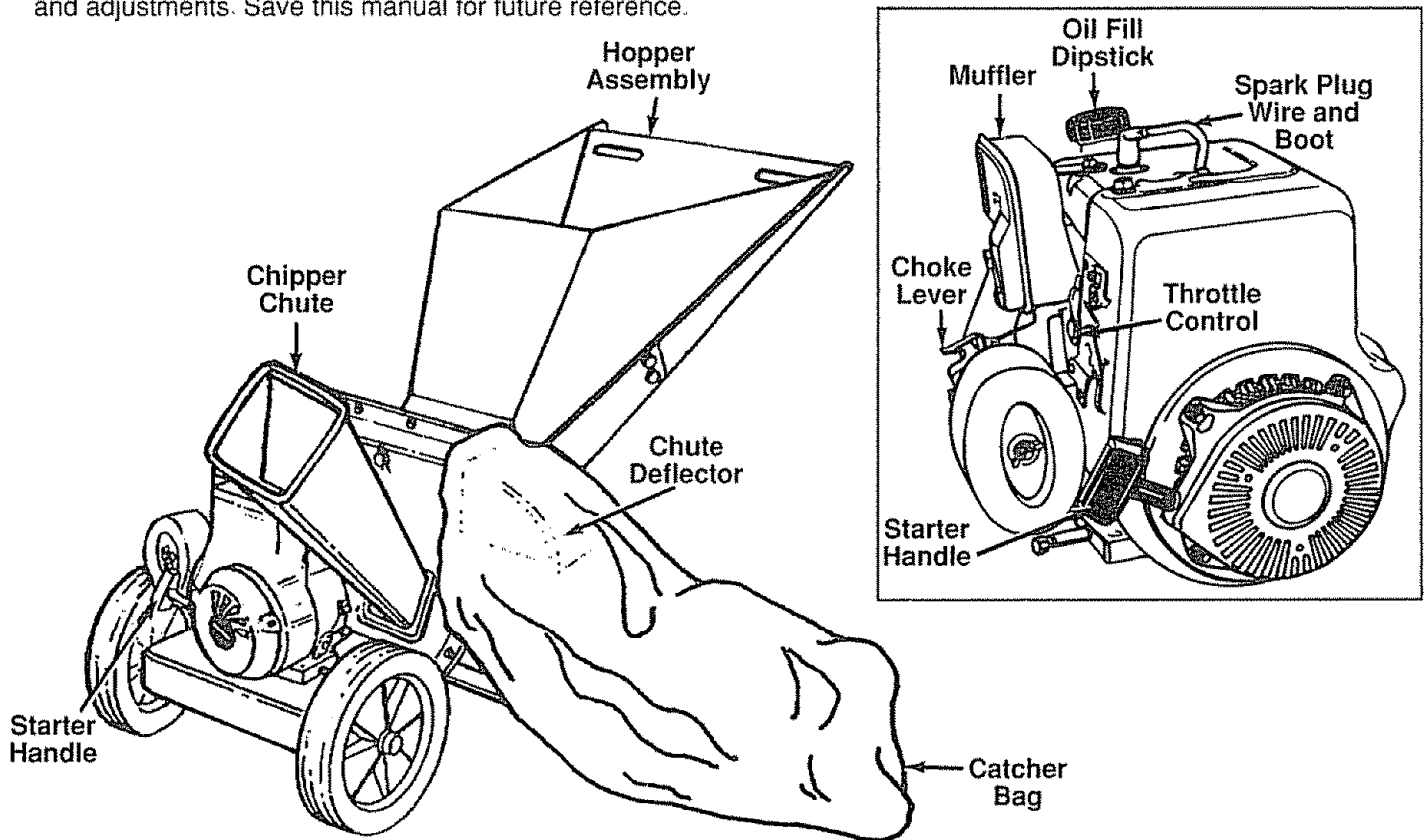

FIGURE 6.

MEETS ANSI SAFETY STANDARDS

Sears chipper-shredders conform to the safety standard B71.6-1982 of the American National Standards Institute.

OPERATING CONTROLS (See figure 6)

RELEASE BAR—Used to release the hopper when raising or lowering

CHOKE LEVER—Used to enrich the fuel mixture in the carburetor when starting a cold engine.

STARTER HANDLE—Used to manually start the engine.

THROTTLE CONTROL—Permits selection of fast or slow engine speed.

BEFORE USING YOUR CHIPPER-SHREDDER, AGAIN REFER TO THE "SAFETY RULES" AS SHOWN ON PAGE 2 OF THIS MANUAL. ALWAYS BE CAREFUL.



The operation of any chipper-shredder can result in foreign objects being thrown into the eyes, which can result in severe eye damage. Always wear the safety glasses provided with the chipper-shredder or eye shields before chipping or shredding, or while performing any adjustments or repairs. We recommend Wide Vision Safety Mask for over spectacles or standard glasses available at Sears Retail or Catalog Stores.

TO STOP ENGINE

- Move throttle control lever to OFF position. See figure 6.
- Disconnect spark plug wire and move away from spark plug to prevent accidental starting while equipment is unattended.

HOW TO USE YOUR CHIPPER-SHREDDER

Do not attempt to shred or chip any material other than vegetation found in a normal yard (i.e., branches, leaves, twigs, etc.).



WARNING: THE CHIPPER-SHREDDER DISCHARGES MATERIALS WITH CONSIDERABLE VELOCITY. KEEP AWAY FROM THE AREA AROUND THE CHUTE DEFLECTOR. ALWAYS STOP THE ENGINE AND DISCONNECT THE SPARK PLUG WIRE WHEN REMOVING OR ATTACHING THE BAG WHEN CHANGING CONTAINERS OR WHEN REMOVING THE SHREDDED MATERIAL. WEAR SAFETY GLASSES AND GLOVES WHENEVER USING YOUR CHIPPER-SHREDDER.

The chipper-shredder is designed for three different methods of operation.

- Leaves and small branches up to 1/2" diameter (recommended) or 1" diameter (maximum) can be fed into the hopper assembly when it is in the raised position. See figure 7. If it becomes necessary to push material into the chipper-shredder, use a small diameter stick—NOT YOUR HANDS. The stick should be small enough that it will be ground up if gets into the impeller assembly.



WARNING: DO NOT PUT MATERIAL LARGER THAN 1/2" IN DIAMETER (RECOMMENDED) or 1" DIAMETER (MAXIMUM) INTO THE HOPPER ASSEMBLY. MATERIAL UP TO A MAXIMUM OF 3" IN DIAMETER MATERIAL MAY BE FED INTO THE CHIPPER CHUTE. DO NOT ATTEMPT TO SHRED OR CHIP ANY MATERIAL LARGER THAN 3" IN DIAMETER. PERSONAL INJURY OR DAMAGE TO THE MACHINE COULD RESULT.

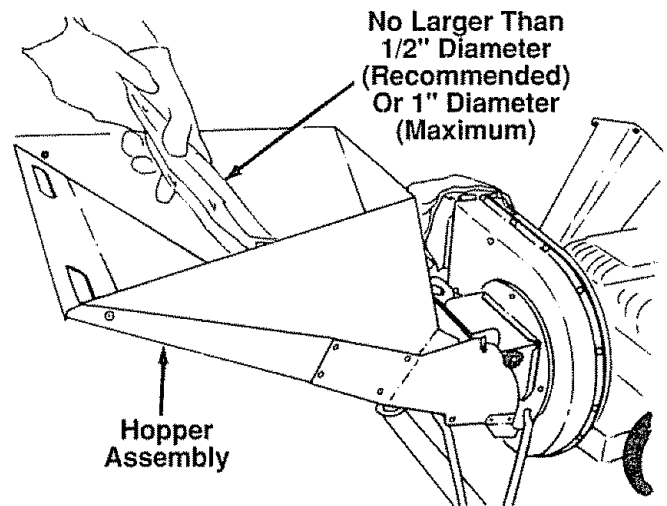

FIGURE 7.

- Leaves and small twigs can be raked into the hopper assembly when the hopper assembly is lowered to the ground. See figure 8. Small branches up to 1/2" diameter (recommended) or 1" diameter (maximum) can also be fed into the hopper assembly in this position. See figure 9.



FIGURE 8.

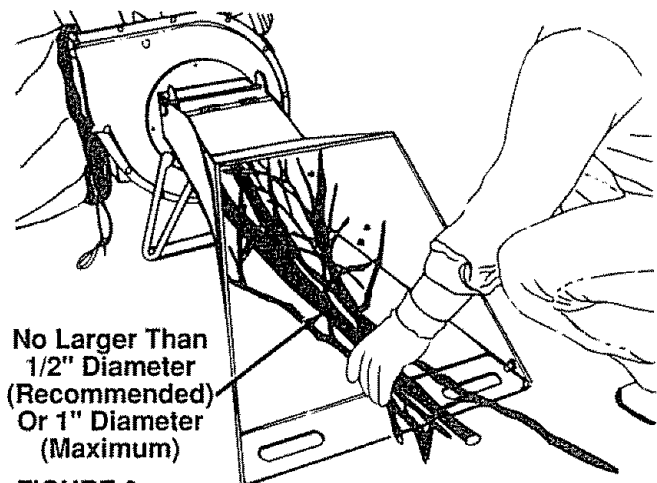

FIGURE 9.

- To lower the hopper assembly, use one hand to grasp the handle at the top of the hopper assembly and lift slightly. Pull up on the release bar, and lower the hopper assembly to the ground. Release the bar. See figure 10.

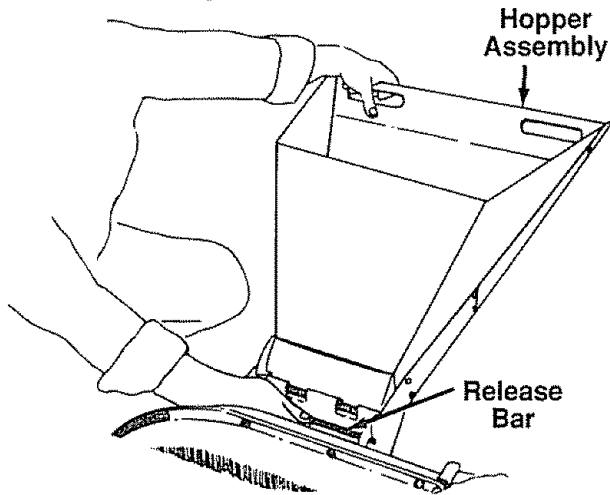

FIGURE 10.

- Bulky material, such as stalks or heavy branches, up to 3" in diameter, should be fed into the chipper chute. See figure 11.



WARNING: MAKE CERTAIN THE CHIPPER CHUTE DOOR IS CLOSED WHEN NOT IN USE.

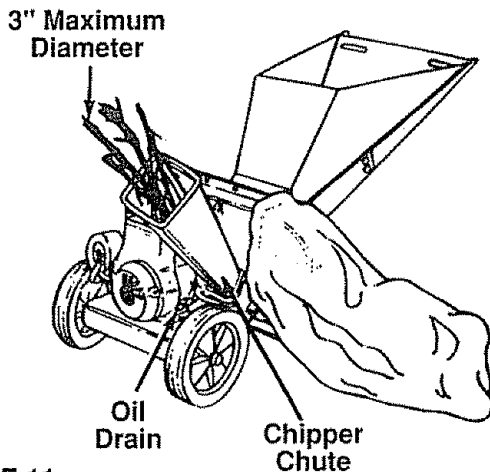

FIGURE 11.

IMPORTANT: There is a flail screen located inside the housing in the discharge area. **If the flail screen becomes clogged**, remove and clean as instructed in the Service and Adjustments section. For best performance, it is important to keep the shredding blade and the chipper blades sharp. If the composition of the material being discharged changes (becomes stringy, etc.) or if the rate at which the material is discharged slows down considerably, it is likely that the shredding blade and/or chipper blades are dull and need to be sharpened or replaced. Refer to Service and Adjustments section.

GAS AND OIL FILL-UP

OIL

Only use high quality detergent oil rated with API service classification SG or SH. Select the oil's viscosity grade according to your expected operating temperature.

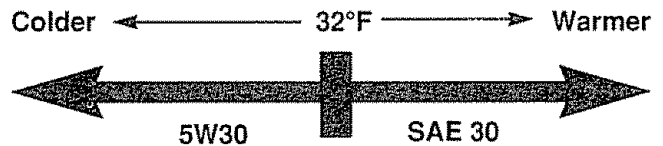

NOTE: Although multi-viscosity oils (5W30, 10W30, etc.) improve starting in cold weather, these multi-viscosity oils will result in increased oil consumption when used above 32°F. Check your oil level more frequently to avoid possible engine damage from running low on oil.

- Fill engine with oil as follows. Remove oil fill dipstick. See figure 12. With chipper-shredder level, use a funnel to fill engine with oil to FULL mark on dipstick. Capacity is approximately 26 ounces. Be careful not to overfill. Tilt chipper-shredder toward the left (from behind the hopper), then re-level. Check oil level. Refill to FULL mark on dipstick if necessary. Replace dipstick and tighten.

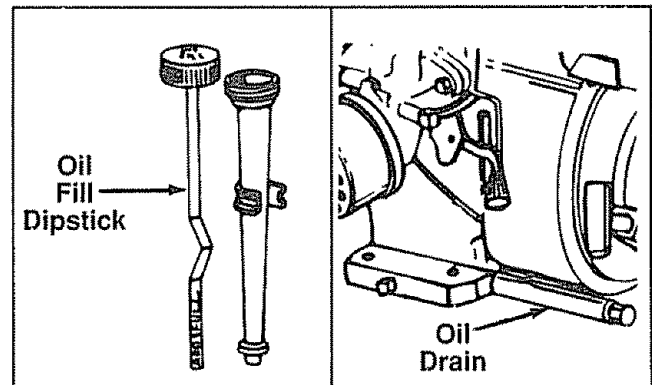

FIGURE 12.

GAS

- Remove fuel cap and fill fuel tank with about 1 gallon of clean, fresh, lead-free grade automotive gasoline. **DO NOT** use Ethyl or high octane gasoline. Be certain container is clean and free from rust or foreign particles. Never use gasoline that may be stale from long periods of storage in the container. Replace fuel cap.



WARNING: DO NOT FILL CLOSER THAN 1/2 INCH OF TOP OF FUEL TANK TO PREVENT SPILLS AND TO ALLOW FOR FUEL EXPANSION. IF GASOLINE IS ACCIDENTLY SPILLED, MOVE CHIPPER-SHREDDER AWAY FROM AREA OF SPILL. AVOID CREATING ANY SOURCE OF IGNITION UNTIL GASOLINE VAPORS HAVE DISAPPEARED.

Check the fuel level periodically to avoid running out of gasoline while operating the chipper-shredder. If the unit runs out of gas as it is shredding or chipping, it may be necessary to unclog the unit before it can be restarted. Refer to "Removing the Flail Screen" in SERVICE AND ADJUSTMENT section.

WARNING: EXPERIENCE INDICATES THAT ALCOHOL BLENDED FUELS (CALLED GASOHOL OR USING ETHANOL OR METHANOL) CAN ATTRACT MOISTURE WHICH LEADS TO SEPARATION AND FORMATION OF ACIDS DURING STORAGE. ACIDIC GAS CAN DAMAGE THE FUEL SYSTEM OF AN ENGINE WHILE IN STORAGE. TO AVOID ENGINE PROBLEMS, THE FUEL SYSTEM SHOULD BE EMPTIED OR TREATED WITH FUEL STABILIZER BEFORE STORAGE FOR 30 DAYS OR LONGER. USE FRESH FUEL NEXT SEASON. SEE "STORAGE" SECTION FOR ADDITIONAL INFORMATION.

NEVER USE ENGINE OR CARBURETOR CLEANER PRODUCTS IN THE FUEL TANK OR PERMANENT DAMAGE MAY OCCUR.

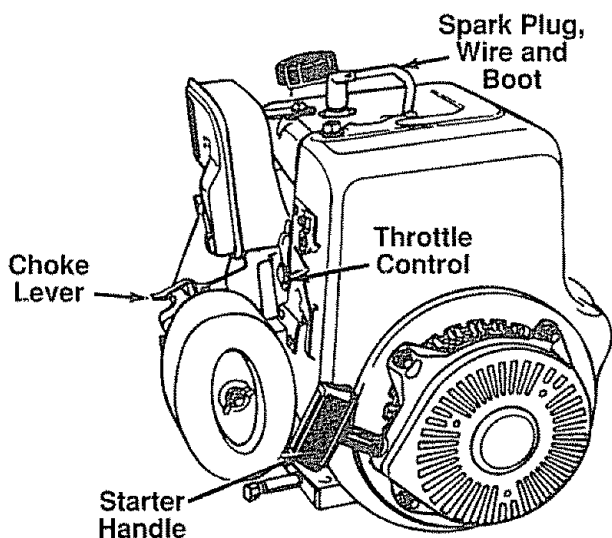

FIGURE 13.

TO START ENGINE



WARNING: BE SURE NO ONE OTHER THAN THE OPERATOR IS STANDING NEAR THE CHIPPER-SHREDDER WHILE STARTING OR OPERATING. DO NOT OPERATE THIS CHIPPER-SHREDDER UNLESS THE CHUTE DEFLECTOR HAS BEEN PROPERLY INSTALLED AND IS SECURED WITH THE HAND KNOBS.

- Attach spark plug wire and rubber boot to spark plug. See figure 13.
- Place the throttle control lever in FAST position.

- Move choke lever down to CHOKE position.
- Grasp starter handle (see figure 13) and pull rope out slowly until engine reaches start of compression cycle (rope will pull slightly harder at this point). Let the rope rewind slowly.

NOTE: A noise will be heard when finding the start of the compression cycle. This noise is caused by the flails and fingers which are part of the shredding mechanism falling into place, and should be expected. In addition, the flails and fingers will be noisy after the engine is started, until the impeller reaches full speed.

- Pull rope with a rapid, continuous, full arm stroke. Keep a firm grip on start handle. Let rope rewind slowly. Do not let starter handle snap back against starter.
- Repeat preceding two instructions until engine fires. When engine starts, move choke lever on engine halfway between CHOKE and OFF.

NOTE: If engine does not fire after three attempts, move choke lever halfway between CHOKE and OFF position and try again. See figure 14.

- Move throttle control to IDLE position for a few minutes warm-up. Move choke lever to OFF position as engine warms up.

NOTE: In order to idle smoothly, a new engine may require 3 to 5 minutes running above slow idle speed. Idle speed has been adjusted to be correct after this break-in period.

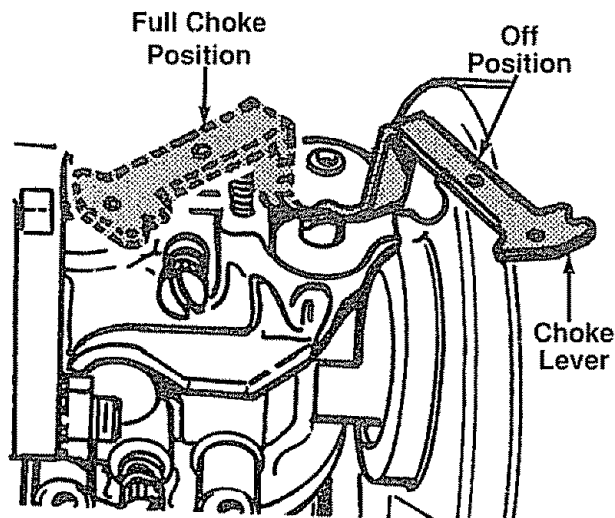

FIGURE 14.

TO STOP ENGINE

- Move throttle control lever to OFF position.
- Disconnect spark plug wire and move away from spark plug to prevent accidental starting while equipment is unattended.

CUSTOMER RESPONSIBILITIES

MAINTENANCE SCHEDULE FILL IN DATES AS YOU COMPLETE REGULAR SERVICE		BEFORE EACH USE	AFTER EACH USE	FIRST FIVE HOURS	EVERY 25 HOURS	EVERY 50 HOURS	BEFORE STORAGE	SERVICE DATES							
PRODUCT	Oil Pivot Points					✓									
	Clean Shredder		✓				✓								
ENGINE	Check Engine Oil	✓													
	Change Engine Oil			✓	✓										
	Service Air Cleaner				✓										
	Clean Engine Cylinder				✓		✓								
	Spark Plug				✓		✓								
	Muffler					✓									

✓ CHECK

GENERAL RECOMMENDATIONS



WARNING: ALWAYS STOP THE ENGINE AND DISCONNECT THE SPARK PLUG WIRE BEFORE PERFORMING ANY MAINTENANCE OR ADJUSTMENTS.

- Periodically check all fasteners and be sure they are tight.
- Follow the Maintenance Schedule above.

CHIPPER-SHREDDER LUBRICATION

Lubricate the pivot points on the release bar, hopper assembly, chute deflector and chipper chute once a season using a light oil.

CLEANING

- The chipper-shredder may be cleaned by running water from a hose through the hopper assembly and chipper chute with the engine running. Allow the chipper-shredder to dry thoroughly.
- Wash the bag periodically with water. Allow to dry thoroughly in the shade. Do not use heat.

ENGINE ENGINE OIL

Only use high quality detergent oil rated with API service classification SG or SH. Select the oil's viscosity grade according to your expected operating temperature.

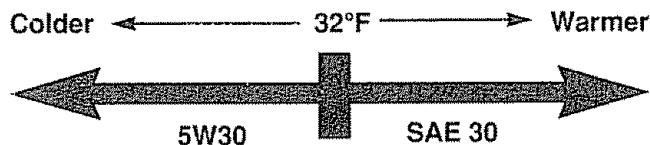

NOTE: Although multi-viscosity oils (SE30, 10W30, etc.) improve starting in cold weather, these multi-viscosity oils will result in increased oil consumption when used above 32°F. Check your oil level more frequently to avoid possible engine damage from running low on oil.

Your four-cycle engine will normally consume some oil—therefore, check engine oil level regularly approximately every five hours of operation and before each usage. Stop engine and wait several minutes before checking oil level. With engine level, the oil must be to FULL mark on dipstick (refer to figure 12). Change engine oil after the first five hours of operation, and every twenty-five hours thereafter.

To Drain Oil:

- Drain oil while engine is warm.
 - a. Remove oil drain plug. Refer to figure 11. Catch oil in a suitable container.
 - b. When engine is drained of all oil, replace drain plug securely.
- Refill with fresh oil. Refer to GAS AND OIL FILL-UP section.
- Replace dipstick.

AIR CLEANER

The air cleaner prevents damaging dirt, dust, etc., from entering the carburetor and being forced into the engine and is important to engine life and performance.

Never run your engine without air cleaner completely assembled.

To Service Air Cleaner:

Service pre-cleaner after every 25 hours of use, or at least once a season. Service filter every 100 hours of use, or at least once a season. Service pre-cleaner and filter more often under dusty conditions.

- Remove wing nut and cover. See figure 15.
- Slide pre-cleaner off filter. Clean the inside of base and cover thoroughly.
- Clean pre-cleaner as follows.
Wash in water and detergent solution, and squeeze (do not twist) until all dirt is removed.
Rinse thoroughly in clear water.
Wrap in a clean cloth and squeeze (do not twist) until completely dry, or allow to air dry.
- If necessary, replace filter (do not attempt to clean).
- Install new filter on base. Slide pre-cleaner over filter.
- Install cover and wing nut. Tighten wing nut securely.

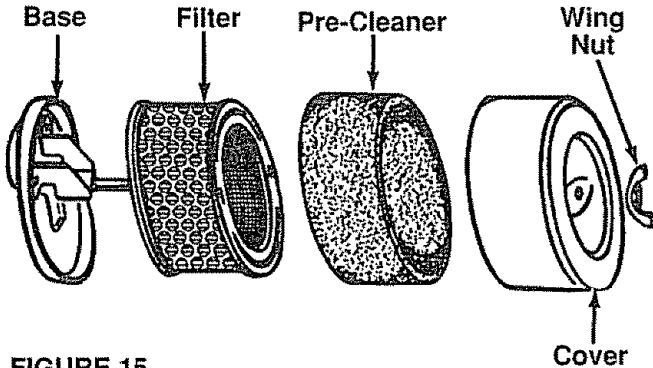

FIGURE 15.

CLEAN ENGINE

Clean engine periodically. Remove dirt and debris with a cloth or brush. Cleaning with a forceful spray of water is not recommended as water could contaminate the fuel system.

Yearly or every 25 hours, whichever occurs first, remove the blower housing and clean the areas shown in figure 16 to avoid overspeeding, overheating and engine damage. Clean more often if necessary.



WARNING: PERIODICALLY CLEAN MUFFLER AREA TO REMOVE ALL GRASS, DIRT AND COMBUSTIBLE DEBRIS.

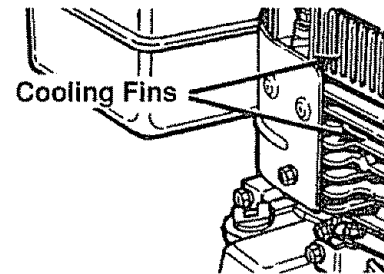

FIGURE 16.

SPARK PLUG

The spark plug should be cleaned and the gap reset to .030" at least once a season or every 50 hours of operation. See figure 17. Spark plug replacement is recommended at the start of each season. Refer to engine parts list for correct spark plug type.

NOTE: Do not sandblast spark plug. Spark plug should be cleaned by scraping or wire brushing and washing with a commercial solvent.

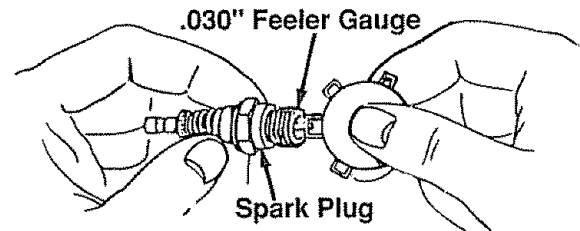

FIGURE 17.

MUFFLER

Do not operate the chipper-shredder without a muffler or tamper with the exhaust system. Damaged mufflers or spark arresters could create a fire hazard. Inspect periodically, and replace if necessary. If your engine is equipped with a spark arrester screen assembly, remove every 50 hours for cleaning and inspection. Replace if damaged.

STORAGE

Prepare your chipper-shredder for storage at the end of the season or if the unit will not be used for 30 days or more.



WARNING: NEVER STORE MACHINE WITH FUEL IN THE FUEL TANK INSIDE OF BUILDING WHERE FUMES MAY REACH AN OPEN FLAME OR SPARK, OR WHERE IGNITION SOURCES ARE PRESENT SUCH AS HOT WATER AND SPACE HEATERS, FURNACES, CLOTHES DRYERS, STOVES, ELECTRIC MOTORS, ETC.

NOTE: A yearly check-up by your local Sears Service Center is a good way to make certain your chipper-shredder will provide maximum performance for the next season.

CHIPPER-SHREDDER

- Clean the chipper-shredder thoroughly.
- Wipe unit with an oiled rag to prevent rust (use a light oil or silicone).

ENGINE

IMPORTANT: IT IS IMPORTANT TO PREVENT GUM DEPOSITS FROM FORMING IN ESSENTIAL FUEL SYSTEM PARTS SUCH AS CARBURETOR, FUEL FILTER, FUEL HOSE, OR TANK DURING STORAGE. ALSO, EXPERIENCE INDICATES THAT ALCOHOL BLENDED FUELS (CALLED GASOHOL OR USING ETHANOL OR METHANOL) CAN ATTRACT MOISTURE WHICH LEADS TO SEPARATION AND FORMATION OF ACIDS DURING STORAGE. ACIDIC GAS CAN DAMAGE THE FUEL SYSTEM OF AN ENGINE WHILE IN STORAGE.

- Drain the fuel tank.
- Start the engine and let it run until the fuel lines and carburetor are empty.
- Never use engine or carburetor cleaner products in the fuel tank or permanent damage may occur.
- Use fresh fuel next season.

NOTE: Fuel stabilizer is an acceptable alternative in minimizing the formation of fuel gum deposits during storage. Add stabilizer to gasoline in fuel tank or storage container. Always follow the mix ratio found on stabilizer container. Run engine at least 10 minutes after adding stabilizer to allow the stabilizer to reach the carburetor. Do not drain the gas tank and carburetor if using fuel stabilizer.

- Drain all the oil from the crankcase (this should be done after the engine has been operated and is still warm) and refill the crankcase with fresh oil.
- If you have drained the fuel tank, protect the inside of the engine as follows. Remove spark plug, pour approximately 1/2 ounce (approximately one tablespoon) of engine oil into cylinder and crank slowly to distribute oil. Replace spark plug.

OTHER

- Do not store gasoline from one season to another.
- Replace your gasoline can if your can starts to rust. Rust and/or dirt in your gasoline will cause problems.
- Store unit in a clean, dry area. Do not store next to corrosive materials, such as fertilizer.

NOTE: If storing in an unventilated or metal storage shed, be certain to rustproof the equipment by coating with a light oil or silicone.

SERVICE & ADJUSTMENT



WARNING: ALWAYS STOP ENGINE AND DISCONNECT SPARK PLUG WIRE AND MOVE IT AWAY FROM SPARK PLUG BEFORE PERFORMING ANY ADJUSTMENTS OR REPAIRS.

REMOVING THE FLAIL SCREEN

If the discharge area becomes clogged, remove the flail screen and clean area as follows.

- Stop the engine, make certain the chipper-shredder has come to a complete stop and disconnect spark plug wire from the spark plug before unclogging the chute.

- Loosen the two hand knobs on each side of the chute deflector. Lift the chute deflector up, and tie it out of the way.
- Remove two hairpin clips from the clevis pins which extend through the housing. Remove the clevis pins. Lift the flail screen from inside the housing. See figure 18.
- Clean the screen by scraping or washing with water. Reinstall the screen.

NOTE: Be certain to reassemble the flail screen with the curved side down as shown in figure 18.

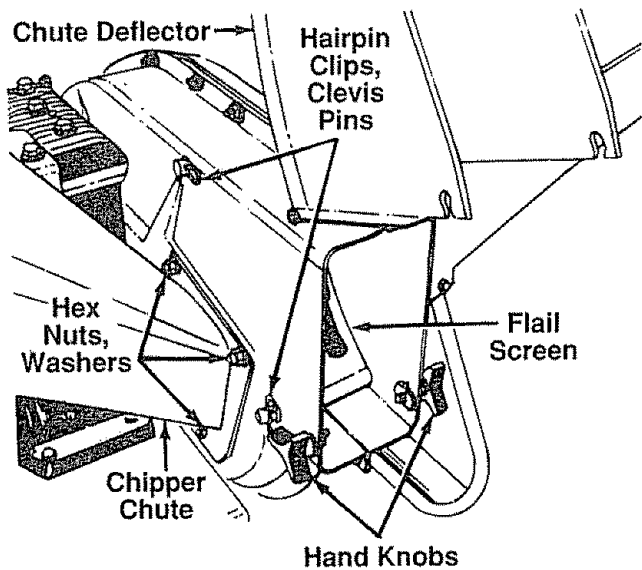

FIGURE 18.

SHARPENING OR REPLACING THE BLADES CHIPPER BLADES

- Disconnect spark plug wire and move it away from spark plug.
- Remove the flail screen as instructed in previous section.
- Remove the chipper chute by removing three hex nuts and washers. A 1/2" wrench is required. See figure 18.

NOTE: When reassembling, the cupped washer goes on the bottom of the chipper chute with the cupped side against the chute.

- Rotate the impeller assembly by hand until you locate one of the chipper blades in the chipper chute opening. Remove the blade, using a 3/16" allen wrench on the outside of the blade and 1/2" wrench on the impeller assembly (inside the housing). See figure 19.
- Remove the other blade in the same manner.

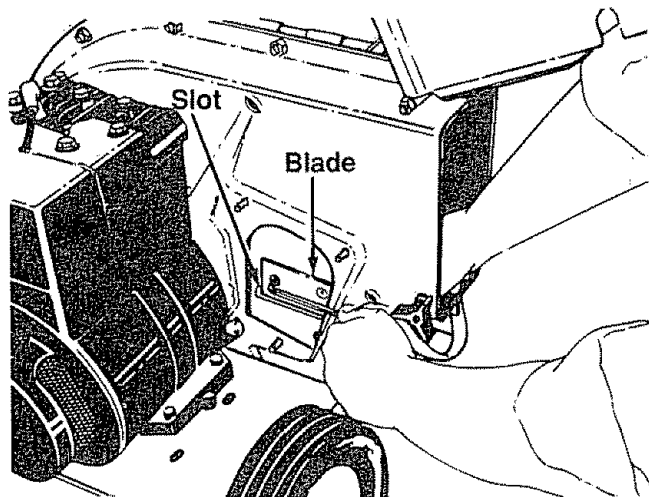

FIGURE 19.

Replace or sharpen blades. If sharpening, make certain to remove an equal amount from each blade. Reassemble in reverse order.

Make certain blades are reassembled with the sharp edge facing the direction shown in figure 18 (sharp edge is assembled toward the slotted opening in the impeller assembly).

SHREDDING BLADE

The shredding blade may be removed for sharpening or replacement as follows.

- Disconnect spark plug wire and move it away from spark plug.
- Lower the hopper assembly. Block up the housing. See figure 20.
- Remove the six hex lock nuts and lock washers from the housing weld bolts using a 1/2" wrench. Separate the chipper-shredder into two halves.
- Remove the back-up plate.

NOTE: When reassembling, make certain the opening on the back-up plate is toward the bottom of the unit. The back-up plate may be reversed to provide a new cutting edge.

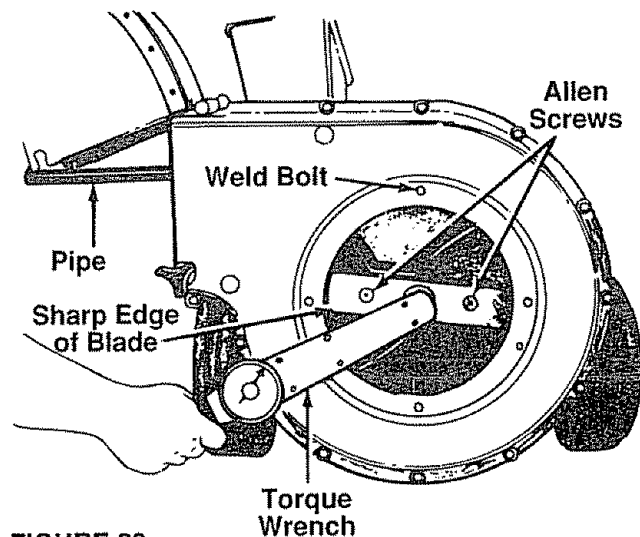

FIGURE 20.

- Loosen the two hand knobs and cupped washers which secure the chute deflector, and raise the chute deflector
- Insert a 1/2" or 3/4" diameter pipe through the flail screen into the impeller to keep it from turning, or remove the flail screen and insert a piece of wood (2 x 4) into the chute opening.
- Remove the two outside screws on the blade, using a 3/16" allen wrench and a 1/2" wrench.
- Remove the blade by removing the center bolt, lock washer and flat washer.

NOTE: Use caution when removing the blade to avoid contacting the weld bolts on the housing.

- When sharpening the blade, follow the original angle of grind as a guide. It is extremely important that each cutting edge receives an equal amount of grinding to prevent an unbalanced blade. An unbalanced blade will cause excessive vibration when rotating at high speeds and may cause damage to the unit.
- The blade can be tested for balance by balancing it on a round shaft screwdriver or nail. Remove metal from the heavy side until it is balanced evenly. See figure 21.

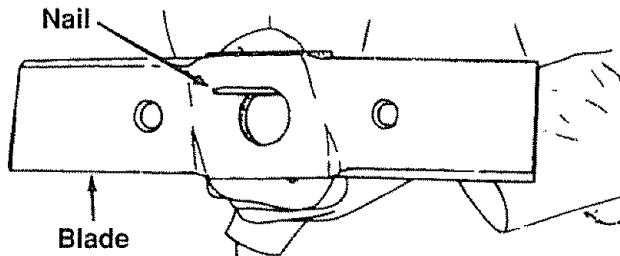

FIGURE 21.

- When reassembling the blade, tighten to between 550 and 650 inch pounds, or lacking torque wrench, tighten securely.

FLAILS

The flails, located inside the housing, may be reversed when they become dull. It is suggested that this procedure be performed by your nearest Sears Service Department.

CARBURETOR ADJUSTMENT



WARNING: IF ANY ADJUSTMENTS ARE MADE TO THE ENGINE WHILE THE ENGINE IS RUNNING (E.G. CARBURETOR), KEEP CLEAR OF ALL MOVING PARTS. BE CAREFUL OF HEATED SURFACES AND MUFFLER.

The carburetor has been pre-set at the factory and should not require adjustment. However, if your engine does not operate properly due to suspected carburetor problems, take your chipper-shredder to your nearest SEARS Service Center.

ENGINE SPEED

Your engine speed has been factory set. Do not attempt to increase engine speed or it may result in personal injury. If you believe the engine is running too fast or too slow, take your chipper-shredder to the nearest SEARS Service Center for repair and adjustment.

TIRES

Recommended operating tire pressure is 35 to 40 p.s.i. (sidewall of tire may give tire manufacturer's recommended pressure). Equal tire pressure should be maintained on both tires. When installing a tire to the rim, be certain rim is clean and free of rust. Lubricate both the tire and rim generously.



WARNING: EXCESSIVE PRESSURE WHEN SEATING BEADS MAY CAUSE TIRE/RIM ASSEMBLY TO BURST WITH FORCE SUFFICIENT TO CAUSE SERIOUS INJURY.

TROUBLE SHOOTING

PROBLEM	POSSIBLE CAUSE(S)	CORRECTIVE ACTION
Engine fails to start	<ul style="list-style-type: none"> • Fuel tank empty, or stale fuel. • Spark plug wire disconnected. • Faulty spark plug • Throttle control not in correct starting position. 	<ul style="list-style-type: none"> • Fill tank with clean, fresh fuel. • Connect wire to spark plug. • Clean, adjust gap or replace. • Move throttle control to FAST position.
Loss of power; operation erratic	<ul style="list-style-type: none"> • Spark plug wire loose. • Unit running on CHOKE. • Blocked fuel line or stale fuel, fresh gasoline. • Water or dirt in fuel system, tank. Refill with fresh fuel. • Carburetor out of adjustment. Service Center. • Dirty air cleaner, section of this manual. 	<ul style="list-style-type: none"> • Connect and tighten spark plug wire. • Move choke lever to OFF position. • Clean fuel line; fill tank with clean • Disconnect fuel line at carburetor to drain fuel • Adjust carburetor or contact your SEARS • Service air cleaner. See Customer Responsibilities
Engine overheats	<ul style="list-style-type: none"> • Carburetor not adjusted properly. • Engine oil level low. 	<ul style="list-style-type: none"> • Contact your SEARS Service Center. • Fill crankcase with proper oil.
Too much vibration	<ul style="list-style-type: none"> • Loose parts or damaged impeller. 	<ul style="list-style-type: none"> • Stop engine immediately and disconnect spark plug wire. Tighten all bolts and nuts. Make all necessary repairs. If vibration continues, have unit serviced by a SEARS Service Center.
Unit does not discharge	<ul style="list-style-type: none"> • Discharge chute clogged • Foreign object lodged in impeller. 	<ul style="list-style-type: none"> • Stop engine immediately and disconnect spark plug wire. Clean flail screen and inside of blower housing. See Service/Adjustments section of this manual. • Stop engine immediately and disconnect spark plug wire. Remove lodged object.
Rate of discharge slows considerably or composition of discharged material changes	<ul style="list-style-type: none"> • Shredding blade and/or chipper blades dull. 	<ul style="list-style-type: none"> • Sharpen or replace shredding and chipper blades.

NOTE: For repairs beyond the minor adjustments listed above, please contact your nearest SEARS Service Center.

SEARS CRAFTSMAN 9 H.P. CHIPPER-SHREDDER MODEL NO. 247.795890
Repair Parts

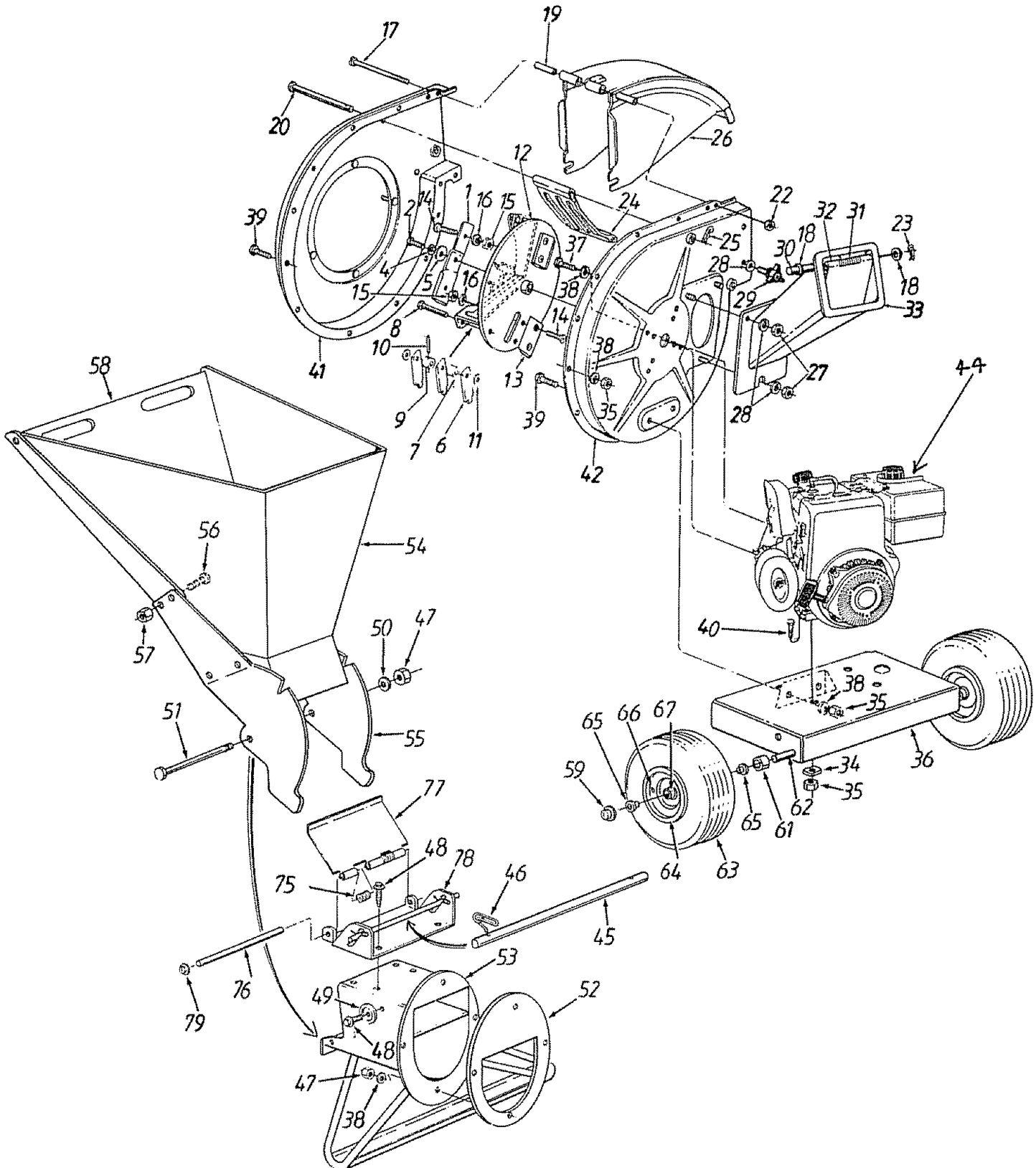

SEARS CRAFTSMAN 9 H.P. CHIPPER-SHREDDER MODEL NO. 247.795890

Repair Parts

KEY NO.	PART NO.	DESCRIPTION	KEY NO.	PART NO.	DESCRIPTION
1	742-0571	Blade	40	710-0442	Hex Bolt 5/16-18 x 1.5" Lg.*
2	710-1254	Hex Patch Bolt 3/8-24 x 2.25" Lg. (Gr. 8)	41	681-0004	Flail Housing Ass'y.—L.H.
4	736-0217	L-Wash. 3/8" I.D. H.D.	42	781-0474A	Flail Housing Ass'y.—R.H.
5	736-0247	Fl-Wash. .406" I.D. x 1.25" O.D. Hdn.	43	735-0639	Spark Plug Boot
6	11459B	Flail — 9 of them	44	143.959001	Engine—143.959001
7	711-0564	Flail Spacer	45	747-0531A	Release Bar
8	711-0833A	Clevis Pin .496" Dia.	46	742-0546	Torsion Spring 1.06" Lg.
9	711-0834	Flail Spacer w/ 160" Dia. Hole	47	712-0429	Elastic Lock Nut 5/16-18 Thd.
10	715-0249	Spring Roll Pin 1.12" Lg.	48	710-0601	Hex Wash. Hd. Self-Tap Scr. 5/16-18 x .75" Lg.
11	736-0192	Fl-Wash. .531" I.D. x .94" O.D.	49	11480	Stop Washer
12	681-0030	Impeller Ass'y. Comp.†	50	736-0264	Fl-Wash. 5/16" I.D.
13	781-0490	Chipper Blade	51	710-0542	Hex Bolt 5/16-18 x 8.38" Lg.
14	710-1054	Flat Hd. Scr. 5/16-24 x .75" Lg.	52	781-0487B	Back-Up Plate
15	712-0411	Hex Top L-Nut 5/16-24 (Gr. 5)	53	16522B	Inlet Guide Ass'y.
16	736-0119	L-Wash. 5/16" I.D.*	54	781-0494	Pivot Hopper Hood
17	710-0825	Hex Bolt 1/4-20 x 3.75" Lg.*	55	16524B	Upper Guide Ass'y.
18	736-0142	Fl-Wash. .281" I.D. x .50" O.D.	56	710-0286	Truss Mach. Scr. 1/4-20 x .5" Lg.
19	750-0793	Chute Hinge Spacer 1.66" Lg.	57	712-0107	Hex L-Nut 1/4-20 Thd.
20	711-0835	Clevis Pin .5" Dia. x 4.62" Lg.	58	11461B	Upper Leaf Ramp Section
22	712-0291	Hex Ctr. L-Nut 1/4-20 Thd.	59	726-0214	Push Cap 5/8" Dia. Rod
23	714-3010	Cotter Pin	61	750-0786	Spacer .64" I.D. x .38" Lg.
24	781-0457	Shredder Screen	62	738-0813	Shredder Axle
25	714-0149B	Internal Cotter Pin 3/8" Dia.	63	734-1597	Wheel Ass'y. Comp.
26	781-0480	Chute Deflector Ass'y.		734-1598	Tire Only
27	712-3010	Hex Nut 5/16-18 Thd. (Gr. 5)	64	734-1455	Rim Only
28	736-0242	Bell-Wash. .345" I.D. x .88"	65	741-0487	Flange Bearing .632" I.D.
29	720-0170	Hand Knob	66	734-0255	Air Valve
30	747-0744A	Chipper Door Rod	67	737-0280	Grease Fitting
31	732-0542	Torsion Spring 1.14" Lg.	75	732-0629	Torsion Spring
32	781-0489	Chipper Door	76	747-0747	Hopper Door Rod
33	781-0475	Chipper Chute Ass'y.	77	781-0492	Hopper—Pivot Door
34	736-0170	Spec. L-Wash. 5/16" I.D.	78	781-0493	Hopper Lockout Brkt.
35	712-3010	Hex Nut 5/16-18 Thd. (Gr. 5)	79	726-0106	Cap Speed Nut 1/4" Rod
36	781-0510A	Shredder Frame	—	764-0199A	Bag (Not Shown)
37	710-0157	Hex Bolt 5/16-24 x .75" Lg.	—	723-0400	Safety Glasses (Not Shown)
38	736-0119	L-Wash. 5/16" I.D.*	—	770-8902K	Owner's Manual
39	710-3008	Hex Bolt 5/16-18 x .75" Lg. (Gr. 5)			

†Incl. Ref. 1, 6, 7, 8, 9, 10, 11, 12, 13, 14

*Common Hardware—May Be Purchased Locally.

NOTE: Specifications subject to change without notice or obligation.

SEARS CRAFTSMAN 9 H.P. ENGINE MODEL NO. 143.959001

Repair Parts

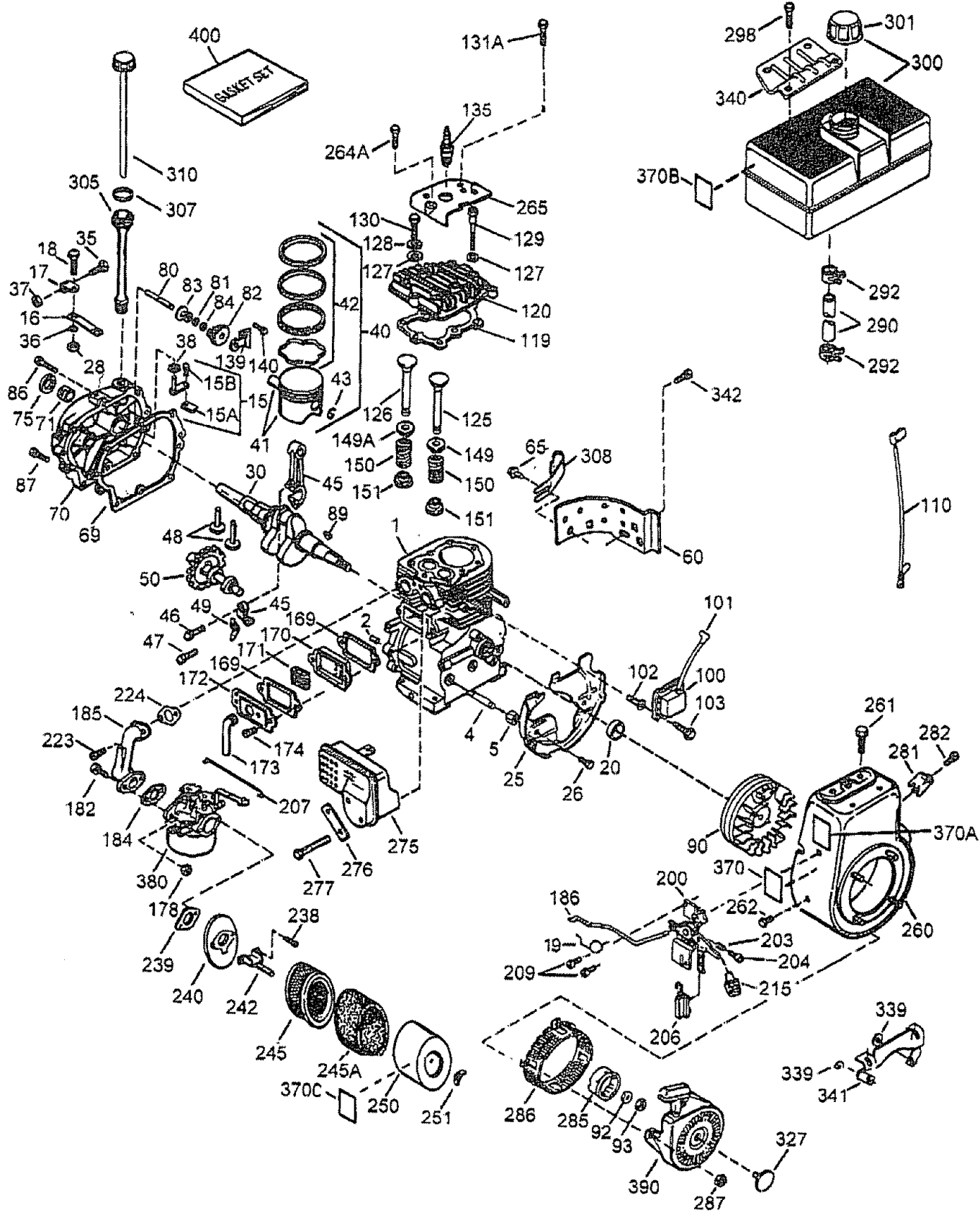

SEARS CRAFTSMAN 9 H.P. ENGINE MODEL NO. 143.959001

Repair Parts

KEY NO.	PART NO.	DESCRIPTION	KEY NO.	PART NO.	DESCRIPTION
1	35385	Cylinder (Incl. 2 & 20)	102	650872	Solid State Mounting Stud
2	27652	Dowel Pin	103	650814	Screw, Torx T-15, 10-24 x 1"
4	34171	Oil Drain Extension	110	35187	Ground Wire
5	30969	Extension Cap	119	36448	Cylinder Head Gasket
15	30699C	Governor Rod	120	36449	Cylinder Head
		(Incl. 15A & 15B)	125	27878A	Exhaust Valve (Std.) (Incl. 151)
15A	30700	Governor Yoke	125	27880A	Exhaust Valve (1/32" OS)
15B	650494	Screw, 6-40 x 5/16"			(Incl. 151)
16	33454	Governor Lever	126	34035	Intake Valve (Std.) (Incl. 151)
17	29916	Governor Lever Clamp	126	34036	Intake Valve (1/32" OS) (Incl. 151)
18	650548	Screw, 8-32 x 5/16"	127	650691	Washer
19	34663	Speed Control Spring	128	650690	Belleville Washer
20	35319	Oil Seal	129	650727	Screw, 5/16-18 x 1-3/4"
25	36460	Blower Housing Baffle	130	650694A	Screw, 5/16-18 x 2"
26	650561	Screw, 1/4-20 x 5/8"	131A	650273	Screw, 5/16-18 x 5/8"
28	30322	Lock Nut, 8-32	135	33636	Resistor Spark Plug (RJ17LM)
30	36283	Crankshaft	139	33369	Governor Gear Bracket
35	29826	Screw, 10-32 x 3/4"	140	650836	Screw, 10-24 x 1/2
36	29918	Lock Washer	149	27882	Valve Spring Cap
37	29216	Lock Nut, 10-32	149A	35862	Valve Spring Cap
38	29642	Retaining Ring	150	27881	Valve Spring
40	34552	Piston, Pin & Ring Set (Std.)	151	32581	Valve Spring Keeper
40	34553	Piston, Pin & Ring Set	169	27896A	Valve Cover Gasket
		(.010" OS)	170	28423	Breather Body
40	34554	Piston, Pin & Ring Set (.020" OS)	171	28424	Breather Element
41	34329A	Piston & Pin Ass'y. (Std.) (Incl. 43)	172	28425	Valve Cover
41	34330A	Piston & Pin Ass'y. (.010" OS)	173	35350	Breather Tube
		(Incl. 43)	174	650128	Screw, 10-24 x 1/2"
41	34331A	Piston & Pin Ass'y. (.020" OS)	178	29752	Nut & Lock Washer, 1/4-28
		(Incl. 43)	182	30088A	Screw, 1/4-28 x 1"
42	34332	Ring Set (Std.)	184	33263	Carburetor To Intake Pipe Gasket
42	34333	Ring Set (.010" OS)	185	34707	Intake Pipe
42	34334	Ring Set (.020" OS)	186	34667	Governor Link
43	27888	Piston Pin Retaining Ring	200	34677	Control Bracket (Incl. 203 & 204)
45	35373A	Connecting Rod Ass'y. (Incl. 46, 47 & 49)	203	31342	Compression Spring
			204	650549	Screw, 5-40 x 7/16"
46	650908	Connecting Rod Bolt	206	610973	Terminal
47	650882	Connecting Rod Bolt	207	33878	Throttle Link
48	34034	Valve Lifter	209	650821	Screw, 10-32 x 1/2"
49	35374	Oil Dipper	215	35882	Control Decal
50	35375	Camshaft (MCR)	223	650378	Screw, Torx T-30, 5/16-18 x 1-1/8"
60	33273A	Blower Housing Extension	224	27915A	Intake Pipe Gasket
65	650128	Screw, 10-24 x 1/2"	238	28820	Screw, 10-32 x 1/2"
69	35262A	Cylinder Cover Gasket	239	27272A	Air Cleaner Gasket
70	35376	Cylinder Cover (Incl. 71, 75 & 80)	240	33266	Air Cleaner Body
71	35377	Crankshaft Bushing	242	33267	Air Cleaner Bracket
72	27642	Oil Drain Plug	245	33268	Air Cleaner Filter
75	35319	Oil Seal	245A	35881	Air Cleaner Filter
80	31845	Governor Shaft	250	33269A	Air Cleaner Cover
81	30590A	Washer	251	650513	Wing Nut, 1/4-20
82	35378	Governor Gear Ass'y. (Incl. 81)	260	36250	Blower Housing
83	30588A	Governor Spool	261	650788	Screw, 5/16-18 x 3/4"
84	29193	Retaining Ring	262	29747B	Screw, Torx T-40, 5/16-24 x 21/32"
86	650833	Screw, 1/4-20 x 1-3/16"			Screw, 1/4-20 x 5/8"
87	650832	Screw, 1/4-20 x 1-11/16"	264A	650802	Cylinder Head Cover
89	32589	Flywheel Key	265	33272B	Muffler
90	611090	Flywheel	275	34185B	Locking Plate
92	650880	Lock Washer	276	31588	Screw, 5/16-18 x 3-3/16"
93	650881	Flywheel Nut	277	650729	Starter Cup
100	35135	Solid State Ignition	285	35985B	Starter Screen
101	610118	Spark Plug Cover	286	35446	

SEARS CRAFTSMAN 9 H.P. ENGINE MODEL NO. 143.959001

Repair Parts

KEY NO.	PART NO.	DESCRIPTION	KEY NO.	PART NO.	DESCRIPTION
287	29752	Nut & Lock Washer, 1/4-28	342	30063	Screw, Torx T-30, 1/4-20 x 1/2"
290	30962	Fuel Line	370	36261	Instruction Decal
292	26460	Fuel Line Clamp	370A	35703	Throttle Decal
298	650665	Screw, 1/4-15 x 3/4"	370B	35532	Logo Decal
300	34186A	Fuel Tank (Incl. 292 & 301)	370C	35274	Instruction Decal
301	35355	Fuel Cap	380	632689	Carburetor (Incl. 184)
305	35554	Oil Fill Tube	390	590671	Rewind Starter
307	35499	"O"-Ring			Note: This engine could have been built with 590704 starter. Refer to the design of the air intake louvers for part identification.
308	35540	Fill Tube Clip			Individual starter parts do not interchange.
310	36205	Dipstick	400	36454	Gasket Set (Incl. Part Nos. 27272A, 27896A, 27915A, 29673, 33263, 33629, 34698A, 35262 & 36448)
325	29443	Wire Clip			
327	35392	Starter Plug			
339	35880	Spacer			
340	34259	Fuel Tank Bracket			
341	34258A	Fuel Tank Bracket			

RPM Setting:
 High Speed: 3450 to 3750
 Low Speed: 1700

OPTIONAL SPARK ARRESTER
 Part No. 34479A ←

(Some as Muffler Cover)

SEARS CRAFTSMAN 9 H.P. ENGINE MODEL NO. 143.959001

Repair Parts

PARTS LIST FOR CARBURETOR

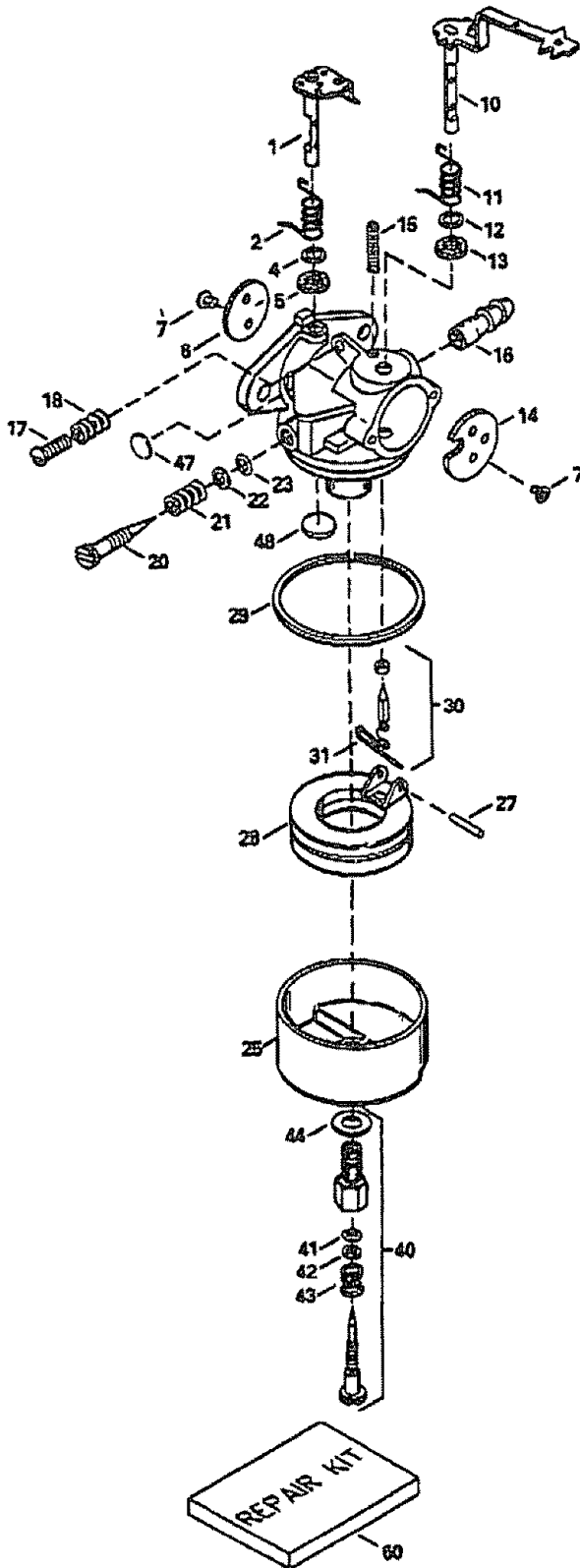

KEY NO.	PART NO.	DESCRIPTION
—	632689	Carburetor (Incl. 184 of Engine Parts List)
1	632243	Throttle Shaft & Lever Assembly
2	632244	Throttle Return Spring
4	631184	Dust Seal Washer
5	631183	Dust Seal (Throttle)
6	632517	Throttle Shutter
7	650506	Shutter Screw
10	632249	Choke Shaft & Lever Assembly
11	632043	Choke Return Spring
12	631184	Dust Seal Washer
13	631183	Dust Seal (Choke)
14	632248	Choke Shutter
15	630735	Choke Positioning Spring
16	632164	Fuel Fitting
17	650417	Throttle Crack Screw/Idle Speed Screw
18	630766	Tension Spring
20	632281	Idle Mixture Screw
21	630766	Tension Spring
22	630739	Idle Mixture Screw Washer
23	630740	Idle Mixture Screw "O"-Ring
25	631867	Float Bowl
27	631024	Float Shaft
28	632019	Float
29	631028	Float Bowl "O"-Ring
30	631021	Inlet Needle, Seat & Clip (Incl. 31)
31	631022	Spring Clip
40	632239	Main Adj. Screw Ass'y. (Incl. 41 thru 44)
41	630740	High Speed Mixture Screw "O"-Ring
42	630739	High Speed Mixture Screw Washer
43	630738	High Speed Mixture Screw Tension Spring
44	27110	Bowl Nut Washer
47	630748	Welch Plug, Idle Mixture Well
48	631027	Welch Plug, Atmospheric Vent
60	632347	Repair Kit* (Incl. Items Marked PK in Notes)

SEARS CRAFTSMAN 9 H.P. ENGINE MODEL NO. 143.959001

Repair Parts

PARTS LIST FOR RECOIL STARTER

KEY NO.	PART NO.	DESCRIPTION
—	590671	Recoil Starter
1	590599A	Spring Pin (Incl. 4)
2	590600	Washer
3	590679	Retainer
4	590601	Washer
5	590678	Brake Spring
6	590680	Starter Dog
7	590412	Dog Spring
8	590681	Pulley & Rewind Spring Ass'y.
11	590683	Starter Housing Ass'y.
12	590456	Starter Rope (114" x 11/64" Dia.)
13	590387	Starter Handle

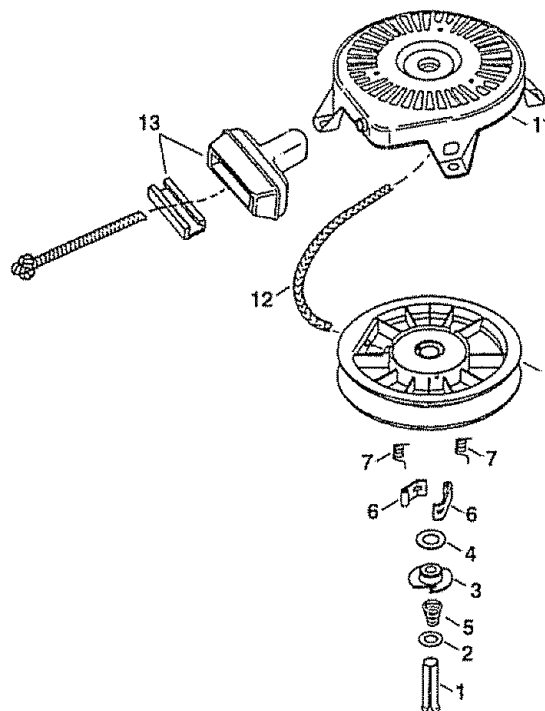

PARTS LIST FOR RECOIL STARTER (OPTIONAL)

KEY NO.	PART NO.	DESCRIPTION
—	590704	Recoil Starter
1	590599A	Spring Pin (Incl. 4)
2	590600	Washer
3	590696	Retainer
4	590601	Washer
5	590697	Brake Spring
6	590698	Starter Dog
7	590699	Dog Spring
8	590700	Pulley & Rewind Spring Ass'y.
11	590705	Starter Housing Ass'y.
12	590535	Starter Rope (98" x 9/64" Dia.)
13	590701	Starter Handle

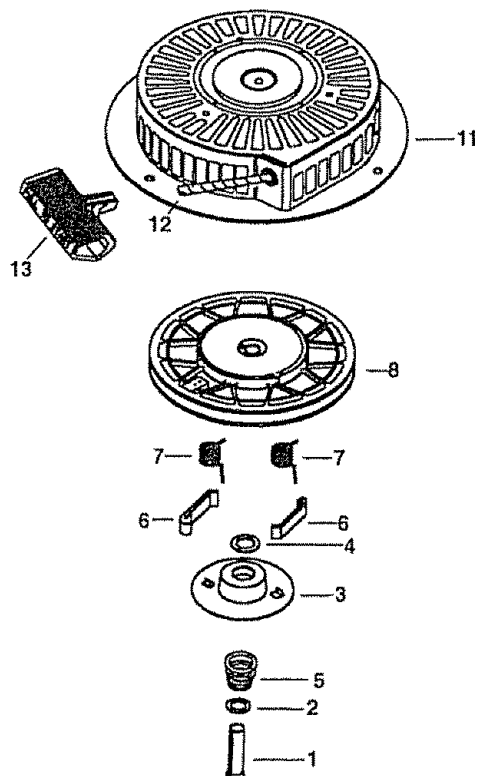

SEARS

OWNER'S MANUAL

MODEL NO.
247.795890

HOW TO ORDER REPAIR PARTS

IF YOU NEED REPAIR
SERVICE OR PARTS:

REPAIR SERVICE
1-800-4-REPAIR
(1-800-473-7247)

ORDERING PARTS
1-800-FON-PART
(1-800-366-7278)

CRAFTSMAN®

9 HORSEPOWER 3 CUTTING STAGE MULCHING AND BAGGING CHIPPER-SHREDDER

Each chipper-shredder has its own model number. Each engine has its own model number.

The model number for your chipper-shredder will be found on a label attached to the frame.

The model number for the engine will be found on the blower housing of the engine.

All parts listed herein may be ordered through Sears, Roebuck and Co. Service Centers and most Retail Stores.

WHEN ORDERING REPAIR PARTS, ALWAYS GIVE THE FOLLOWING INFORMATION:

*PRODUCT - "9 H.P. Chipper-Shredder"

*MODEL NUMBER - 247.795890

*ENGINE MODEL NO. - 143.959001

*PART NUMBER

*PART DESCRIPTION

Your Sears merchandise has added value when you consider that Sears has service units nationwide staffed with Sears trained technicians...professional technicians specifically trained on Sears products, having the parts, tools and the equipment to insure that we meet our pledge to you..."we service what we sell."