

SEARS

**OWNER'S
MANUAL**

**MODEL NOS.
247.885550
247.885680**

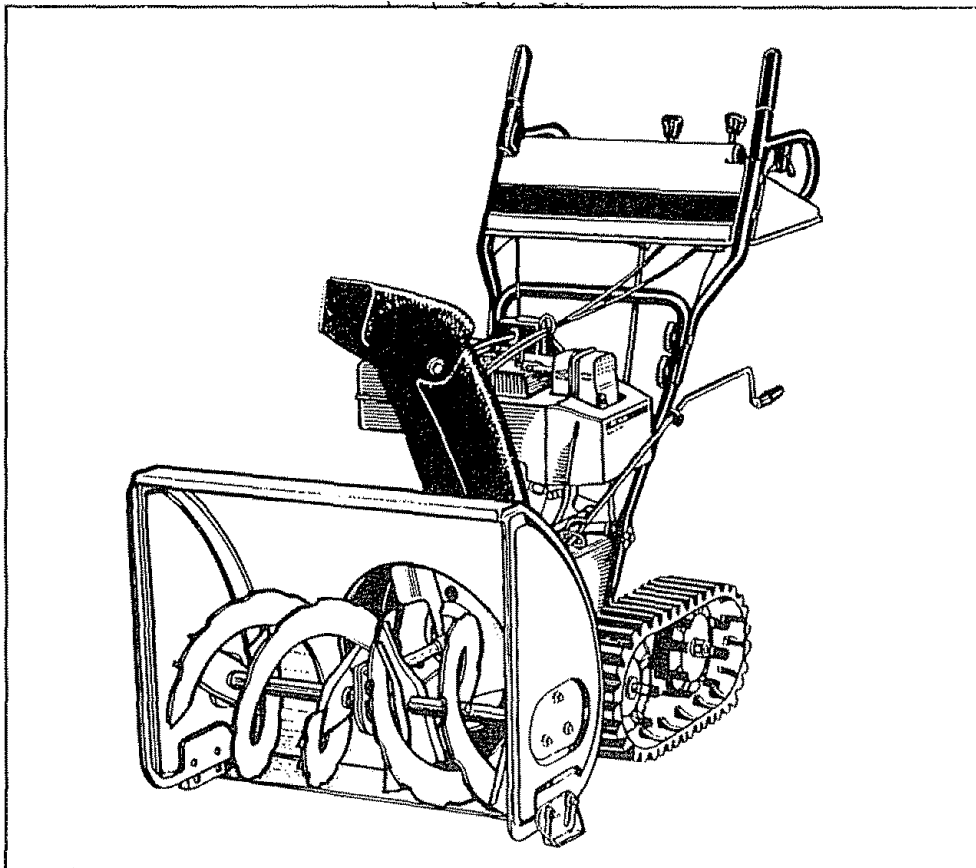

CRAFTSMAN®

**5 AND 8 HORSEPOWER
24" AND 26" WIDTH
TWO STAGE
TRACK DRIVE
SNOW THROWERS**

**Caution:
Read and Follow
All Safety Rules
and Instructions
Before Operating
This Equipment**

**Assembly
Operation
Customer Responsibilities
Service and Adjustment
Repair Parts**

SEARS, ROEBUCK AND CO., Chicago, IL 60684 U.S.A.

770-8738K

SAFETY RULES



WARNING: TO REDUCE THE POTENTIAL FOR ANY INJURY, COMPLY WITH THE FOLLOWING SAFETY INSTRUCTIONS. FAILURE TO COMPLY WITH THE INSTRUCTIONS MAY RESULT IN PERSONAL INJURY.



TRAINING

- Read this owner's guide carefully in its entirety before attempting to assemble or operate this machine. Be completely familiar with the controls and the proper use of this machine before operating it. Keep this manual in a safe place for future and regular reference and for ordering replacement parts.
- Never allow children under 14 years old to operate a snow thrower. Children 14 years old and over should only operate snow thrower under close parental supervision. Only persons well acquainted with these rules of safe operation should be allowed to use your snow thrower.
- No one should operate this unit while intoxicated or while taking medication that impairs the senses or reactions.
- Keep the area of operation clear of all persons, especially small children and pets.
- Exercise caution to avoid slipping or falling, especially when operating in reverse.



PREPARATION

- Thoroughly inspect the area where the equipment is to be used and remove all door mats, sleds, boards, wires and other foreign objects.
- Disengage all clutches and shift into neutral before starting engine.
- Do not operate equipment without wearing adequate winter outer garments. Do not wear jewelry, long scarfs or other loose clothing which could become entangled in moving parts. Wear footwear which will improve footing on slippery surfaces.
- Before working with gasoline, extinguish all cigarettes and other sources of ignition. Check the fuel before starting the engine. Gasoline is an extremely flammable fuel. Do not fill the gasoline tank indoors, while the engine is running, or until engine has been allowed to cool at least two minutes. Replace gasoline cap securely and wipe off any spilled gasoline before starting the engine as it may cause a fire or explosion.
- Use a grounded three wire plug-in for all units with electric drive motors or electric starting motors.
- Adjust collector housing height to clear gravel or crushed rock surface.
- Never attempt to make any adjustments while engine is running (except where specifically recommended by manufacturer).
- Let engine and machine adjust to outdoor temperature before starting to clear snow.
- Always wear safety glasses or eye shields during operation or while performing an adjustment or repair, to protect eyes from foreign objects that may be thrown from the machine in any direction.



OPERATION

- Do not put hands or feet near or under rotating parts. Keep clear of discharge opening and auger at all times.
- Exercise extreme caution when operating on or crossing gravel drives, walks, or roads. Stay alert for hidden hazards or traffic. Do not carry passengers.
- After striking a foreign object, stop the engine, remove wire from spark plug, and thoroughly inspect the snow thrower for any damage. Repair the damage before restarting and operating the snow thrower.
- If the snow thrower should start to vibrate abnormally, stop the engine and check immediately for the cause. Vibration is generally a warning of trouble.

- Stop engine whenever you leave the operating position, before unclogging the collector/impeller housing or discharge guide, and making any repairs, adjustments, or inspections. Never place your hand in the discharge or collector openings. Use a stick or wooden broom handle to unclog the discharge opening.
- Take all possible precautions when leaving the unit unattended. Disengage the collector/impeller, shift into neutral, stop the engine, and remove the key.
- When cleaning, repairing, or inspecting, make certain collector/impeller and all moving parts have stopped. Disconnect spark plug wire and keep away from plug to prevent accidental starting.
- Do not run engine indoors, except when starting engine and transporting snow thrower in or out of building. Open doors. Exhaust fumes are dangerous.
- Do not clear snow across the face of slopes. Exercise extreme caution when changing direction on slopes. Do not attempt to clear steep slopes.
- Never operate snow thrower without guards, plates, or other safety protection devices in place.
- Never operate snow thrower near glass enclosure, automobiles, window wells, drop off, etc., without proper adjustments of snow thrower discharge angle. Keep children and pets away.
- Do not overload machine capacity by attempting to clear snow at too fast a rate.
- Never operate the machine at high transport speeds on slippery surfaces. Look behind and use care when backing.
- Never direct discharge at bystanders or allow anyone in front of unit.
- Disengage power to collector/impeller when transporting or not in use.
- Use only attachments and accessories approved by the manufacturer of snow thrower (such as wheel weights, counter weights, cabs, etc.).
- Never operate the snow thrower without good visibility or light. Always be sure of your footing and keep a firm hold on the handles. Walk, never run.
- Muffler and engine become hot and can cause a burn. Do not touch.



MAINTENANCE AND STORAGE

- Check shear bolts, engine mounting bolts, etc., at frequent intervals for proper tightness to be sure equipment is in safe working condition.
- Never store the machine with fuel in the fuel tank inside a building where ignition sources are present, such as hot water and space heaters, clothes dryers, and the like. Allow engine to cool before storing in any enclosure.
- Always refer to owner's guide instructions for important details if snow thrower is to be stored for an extended period.
- Run machine a few minutes after throwing snow to prevent freeze up of collector/impeller.
- Check clutch controls periodically to verify they engage and disengage properly and readjust if necessary. Refer to owner's guide for adjustment instructions.



LOOK FOR THIS SYMBOL TO POINT OUT IMPORTANT SAFETY PRECAUTIONS. IT MEANS—ATTENTION!!! BECOME ALERT!!! YOUR SAFETY IS INVOLVED.

CONGRATULATIONS on your purchase of a Sears Craftsman snow thrower. It has been designed, engineered and manufactured to give you the best possible dependability and performance.

Should you experience any problem you cannot easily remedy, please contact your nearest Sears Service Center/Department in the United States. We have competent, well-trained technicians and the proper tools to service or repair this unit.

Please read and retain this manual. The instructions will enable you to assemble and maintain your snow thrower properly. Always observe the "SAFETY RULES."

MODEL NUMBER _____
SERIAL NUMBER _____
DATE OF PURCHASE _____
THE MODEL AND SERIAL NUMBERS WILL BE FOUND ON A LABEL ATTACHED TO THE FRAME OF THE SNOW THROWER.
YOU SHOULD RECORD BOTH SERIAL NUMBER AND DATE OF PURCHASE AND KEEP IN A SAFE PLACE FOR FUTURE REFERENCE.

CUSTOMER RESPONSIBILITIES

- Read and observe the safety rules.
- Follow a regular schedule in maintaining, caring for and using your snow thrower.
- Follow the instructions under "Customer Responsibilities" and "Storage" sections of this Owner's Manual.

PRODUCT SPECIFICATIONS

Horsepower:	5.0	8.0
Displacement:	13.53 cu. in.	19.43 cu. in.
Fuel Capacity:	2 Qts. (Unleaded)	1 Gal. (Unleaded)
Spark Plug (Gap .030 in.):	J-8C or Equivalent	J-8C or Equivalent
Ignition Air Gap:	.0125"	.0125"

MAINTENANCE AGREEMENT

A Sears Maintenance Agreement is available on this product. Contact your nearest Sears store for details.

WARNING: This unit is equipped with an internal combustion engine and should not be used on or near any unimproved forest-covered, brush-covered or grass-covered land unless the engine's exhaust system is equipped with a spark arrester meeting applicable local or state laws (if any). If a spark arrester is used, it should be maintained in effective working order by the operator.

In the State of California the above is required by law (Section 4442 of the California Public Resources Code). Other states may have similar laws. Federal laws apply on federal lands. A spark arrester for the muffler is available through your nearest Sears Authorized Service Center. (See the REPAIR PARTS section of this manual.)

ONE YEAR LIMITED WARRANTY ON CRAFTSMAN GAS SNOW THROWER

For one year from the date of purchase, when this Craftsman Snow Thrower is maintained, lubricated and tuned up according to the instructions in the owner's manual, Sears will repair, free of charge, any defect in material and workmanship.

If this Craftsman snow thrower is used for commercial or rental purposes, this warranty applies for only 30 days from the date of purchase.

This warranty does not cover:

- Expendable items which become worn during normal use, such as skid shoes, shave plate and spark plugs.
- Repairs necessary because of operator abuse or negligence, including bent crankshafts and the failure to maintain the equipment according to the instructions contained in the owner's manual.

WARRANTY SERVICE IS AVAILABLE BY RETURNING THE CRAFTSMAN SNOW THROWER TO THE NEAREST SEARS SERVICE CENTER/DEPARTMENT IN THE UNITED STATES. THIS WARRANTY APPLIES ONLY WHILE THIS PRODUCT IS IN USE IN THE UNITED STATES.

This warranty gives you specific legal rights, and you may also have other rights which may vary from state to state.

SEARS, ROEBUCK AND CO., D/817WA, Hoffman Estates, IL 60179

TABLE OF CONTENTS

SAFETY RULES	2	STORAGE	17
PRODUCT SPECIFICATIONS	3	SERVICE AND ADJUSTMENT	17
WARRANTY	3	TROUBLE SHOOTING	21
INDEX	4	REPAIR PARTS—SNOW THROWER	22
ASSEMBLY INSTRUCTIONS	5	REPAIR PARTS—ENGINE	31
OPERATION	10	PARTS ORDERING/SERVICE	BACK COVER
CUSTOMER RESPONSIBILITIES	15		

INDEX

<p style="text-align: center;">A</p> <p>Adjustments:</p> <ul style="list-style-type: none"> Auger Clutch Carburetor Shift Rod Skid Shoes Traction Drive Clutch <p>Assembly Instructions:</p> <ul style="list-style-type: none"> Chute Chute Crank Clutch Cables Final Adjustments Handle Hardware Pack Shift Rod Track Controls <p style="text-align: center;">C</p> <p>Controls</p> <p>Customer Responsibilities</p> <p style="text-align: center;">E</p> <p>Engine:</p> <ul style="list-style-type: none"> Lubrication Maintenance Starting Stopping Storage 	<p style="text-align: center;">F</p> <p>Fuel</p> <p style="text-align: center;">L</p> <p>Lubrication</p> <p style="text-align: center;">M</p> <p>Maintenance:</p> <ul style="list-style-type: none"> Agreement Schedule Engine <p style="text-align: center;">O</p> <p>Oil</p> <p>Operating Tips</p> <p style="text-align: center;">R</p> <p>Repair/Replacement Parts</p> <p>Responsibilities, Customer</p> <p style="text-align: center;">S</p> <p>Safety Rules</p> <p>Spark Plug</p> <p>Specifications</p> <p>Storage</p> <p style="text-align: center;">T</p> <p>Table of Contents</p> <p style="text-align: center;">W</p> <p>Warranty</p>
---	---

SNOW THROWER ACCESSORIES

These accessories were available when the snow thrower was purchased. They are also available at most Sears retail outlets, catalog and service centers. Most Sears stores can order repair parts for you, when you provide the model number of your snow thrower.

ENGINE

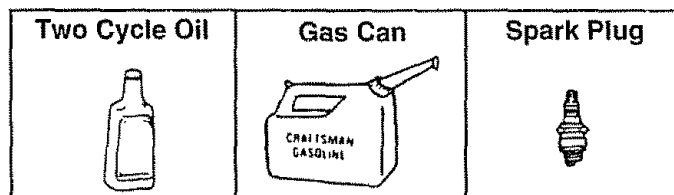

SNOW THROWER MAINTENANCE

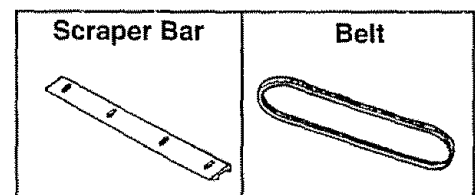

ASSEMBLY INSTRUCTIONS

IMPORTANT: This unit has been shipped **WITHOUT GASOLINE or OIL.** After assembly, see operation section of this manual for proper fuel and engine oil recommendations.

NOTE: To determine right and left hand sides of your snow thrower, stand behind it in the normal operating position.

TO REMOVE SNOW THROWER FROM CARTON

Cut the corners of the carton. Remove all packing inserts. Roll snow thrower out of the carton. Make certain all parts and literature have been removed before the carton is discarded.

Tools Required for Assembly:

- 1/2" Wrench*
- (2) 7/16" Wrenches*
- Pair of Pliers
- *or Adjustable Wrenches

Loose Parts in Carton:

- (1) Handle Panel and Chute Assembly (attached by cable)
- (1) Right Hand Handle
- (1) Left Hand Handle
- (1) Chute Crank Assembly
- (1) Shift Rod

CONTENTS OF HARDWARE PACK

Lay out the hardware according to the illustration for identification purposes. Part numbers are shown in parentheses.

<p>A ATTACHING THE HANDLE ASSEMBLY</p> <p>Hex Bolts 5/16-18 x 1-3/4" Long (710-3180)</p> <p>Hex Nuts* 1/4-20 Thread (736-0287)</p> <p>Hex Bolts 5/16-18 x 5/8" Long (710-0538)</p> <p>Lock Washers 5/16" I.D. (736-0119)</p> <p>Cupped Washers* 1/4" I.D. (736-0270)</p> <p>Hex Bolts* 1/4-20 x 7/8" Long (710-0252)</p> <p>Carriage Bolts 5/16-18 x 1-1/2" Long (710-1250)</p> <p>Cupped Washers* 5/16" I.D. (736-0242)</p> <p>Hex Nuts* 5/16-18 Thread (712-0267)</p> <p>*May be preassembled on your unit.</p>	<p>B ATTACHING THE CHUTE ASSEMBLY</p> <p>Hex Bolts 1/4-20 x 3/4" Long (710-3015)</p> <p>Hex Lock Nuts 1/4-20 Thread (712-3027)</p> <p>Chute Flange Keepers (731-0851)</p>
<p>C ATTACHING THE CHUTE CRANK</p> <p>Flat Washers 3/8" I.D. x 5/8" O.D. (736-0140)</p> <p>Hex Bolt 5/16-18 x 1-1/2" Long (710-0442)</p> <p>Lock Washer 5/16" I.D. (736-0119)</p> <p>Cotter Pin (714-0507)</p> <p>Hex Nut 5/16-18 Thread (712-0267)</p>	<p>D ATTACHING THE SHIFT ROD AND CLUTCH CABLES</p> <p>Ferrule (711-0677)</p> <p>Hairpin Clips (714-0104)</p> <p>Flat Washers 5/16" I.D. x 5/8" O.D. (736-0264)</p> <p>Spring Washer 5/16" I.D. (736-0271)</p> <p>Hex Nuts (Come with Clutch Cables)</p>
<p>E AUGER SHEAR BOLTS</p> <p>Hex Bolts 5/16-18 x 1-1/2" Long (710-0890)</p> <p>Hex Lock Nuts 5/16-18 Thread (712-0158)</p> <p>The augers are secured to the spiral shaft with two hex bolts and hex insert lock nuts. If you hit a foreign object or ice jam, the snow thrower is designed so that the hex bolts will shear. Two replacement hex bolts and nuts are provided for your convenience. Store in a safe place until needed.</p>	

ASSEMBLY INSTRUCTIONS

HOW TO SET-UP YOUR SNOW THROWER



WARNING: MAKE CERTAIN THE SPARK PLUG WIRE IS DISCONNECTED AND MOVED AWAY FROM THE SPARK PLUG BEFORE ASSEMBLING THE SNOW THROWER.

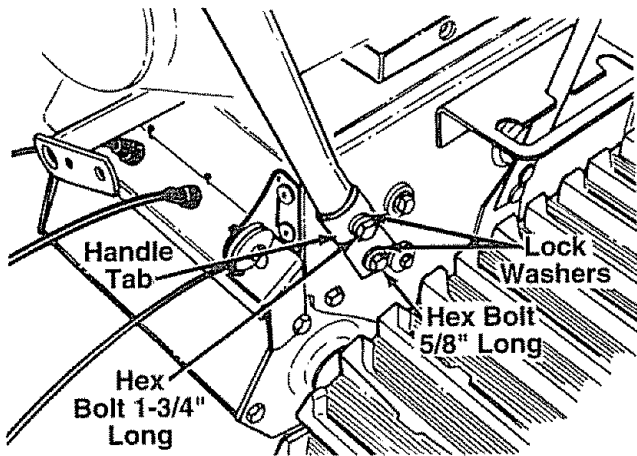

FIGURE 1.

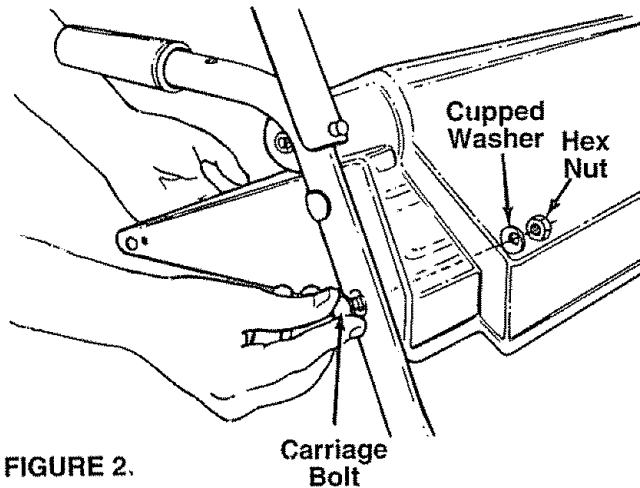

FIGURE 2.

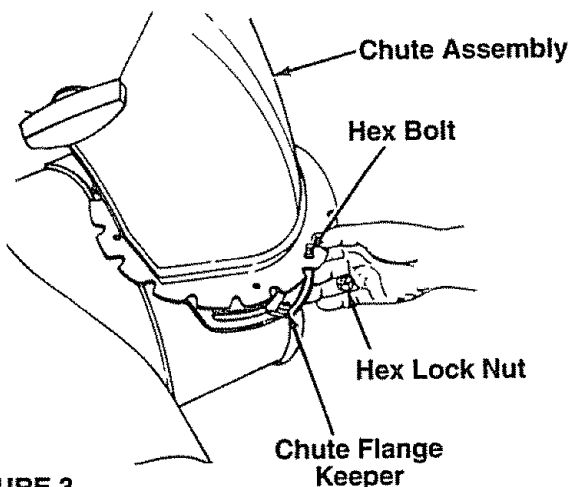

FIGURE 3.

ATTACHING THE HANDLE ASSEMBLY (Hardware A)

- Stretch out control cables and place on the floor.
- Place right handle in position with flat side against the snow thrower. Secure bottom holes in handle to snow thrower using hex bolts 5/8" long and lock washers. See figure 1. Do not tighten at this time.
- Place handle tabs over the upper holes in handle, so the curve in the handle tab matches the curve in the handles. Secure to the snow thrower using hex bolts 1-3/4" long and lock washers. Do not tighten at this time.
- Attach the left handle in the same manner. Do not tighten at this time.
- Place the handle panel in position between the handles. Secure with four carriage bolts, cupped washers (cupped side against the handle panel) and hex nuts as shown in figure 2.
- Tighten the four hex bolts used to attach the bottom of the handles to the snow thrower frame.

ATTACHING THE CHUTE ASSEMBLY (Hardware B)

- Grease the chute opening using a multi-purpose automotive grease or equivalent.
- Place chute assembly over chute opening, with the opening in the chute assembly facing the front of the unit. Place chute flange keepers beneath lip of chute assembly. Insert hex bolt up through chute flange keeper and chute assembly as shown in figure 3. Secure with hex lock nut. After assembling all three chute flange keepers, tighten then back off 1/4 turn to allow easier movement.

ASSEMBLY INSTRUCTIONS

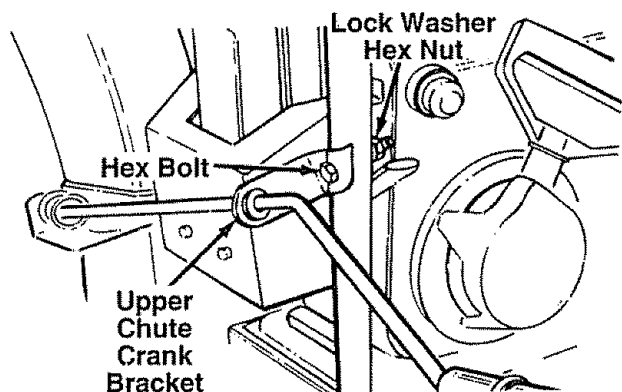

FIGURE 4.

ATTACHING THE CHUTE CRANK (Hardware C)

- Insert hex bolt through the upper chute crank bracket. See figure 4.
- Place the hex bolt into the hole provided in the left handle. Secure with lock washer and hex nut. Do not tighten until after attaching the other end of the chute crank.

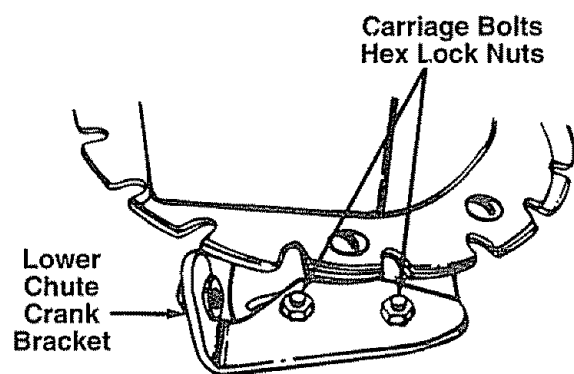

FIGURE 5.

- Loosen the carriage bolts and hex lock nuts which secure the lower chute crank bracket to the extension on the left side of the chute assembly. See figure 5.

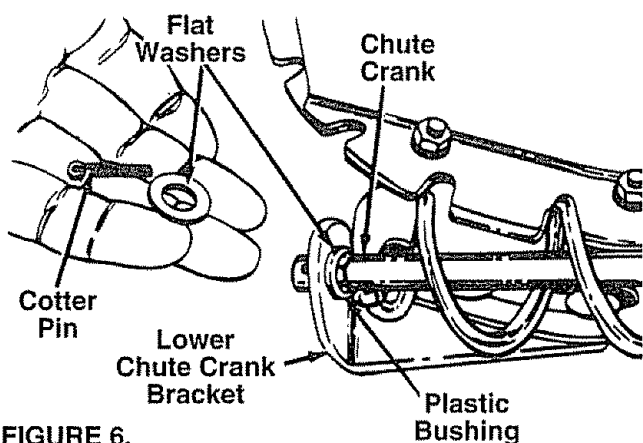

FIGURE 6.

- Place one flat washer on the end of the chute crank, then insert the end of the crank into the hole in the plastic bushing in the chute crank bracket. See figure 6. Place the other flat washer on the end of the chute crank, and insert cotter pin into hole in the end of crank. Secure by bending the ends of cotter pin in opposite directions.
- Adjust the chute bracket so that the spiral on the chute crank fully engages the teeth on the chute assembly. Tighten the nuts on the lower chute crank bracket securely. Tighten the hex bolt and nut on the upper chute crank bracket on the handle.

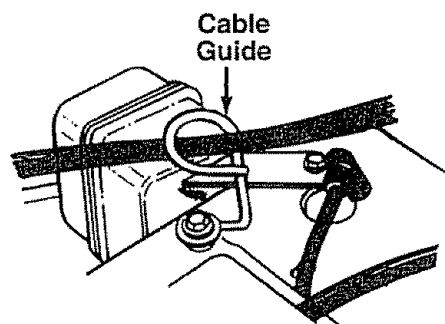

FIGURE 7.

- Slip the cables that run from the handle panel to the chute into the cable guide located on top of the engine. See figure 7.

ASSEMBLY INSTRUCTIONS

IMPORTANT: Attach the shift rod and clutch cables as follows. **THEN CHECK THE ADJUSTMENTS AS INSTRUCTED, AND MAKE ANY FINAL ADJUSTMENTS NECESSARY BEFORE OPERATING YOUR SNOW THROWER.** Failure to follow the instructions may cause damage to the snow thrower.

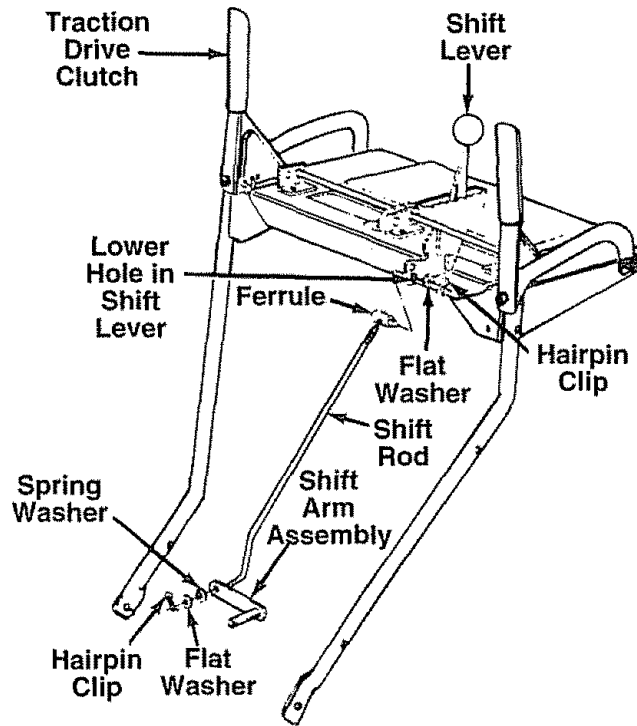

FIGURE 8.

ATTACHING THE SHIFT ROD (Hardware D)

- Insert the ferrule through the lower hole in the shift lever beneath the handle panel from the right side. Secure with flat washer and hairpin clip. See figure 8.
- Place the shift lever in the sixth (6) speed position (all the way forward).
- Start threading the shift rod into the ferrule. Push down on the shift arm assembly as far as it will go. Thread shift rod into the ferrule until the end of the shift rod lines up with the hole in the shift arm assembly. Secure with spring washer, flat washer and hairpin clip.

Make certain to check for correct adjustment of the shift rod as instructed in the Final Adjustment section before operating the snow thrower.

ATTACHING THE CLUTCH CABLES

The "Z" ends of the clutch cables are hooked into the clutch grips on each handle. Attach cables as follows.

- Thread the hex lock nuts (in hardware pack) all the way up the threaded portion of the "Z" ends of the clutch cables.
- Make certain each cable is in groove of cable roller guides. Place the clutch grip in the raised (up) position.
- Thread the cable onto the threaded portion of the "Z" and until there is no slack in the cable, but the cable is **NOT tight**. Do not overtighten cable.

See figure 9.

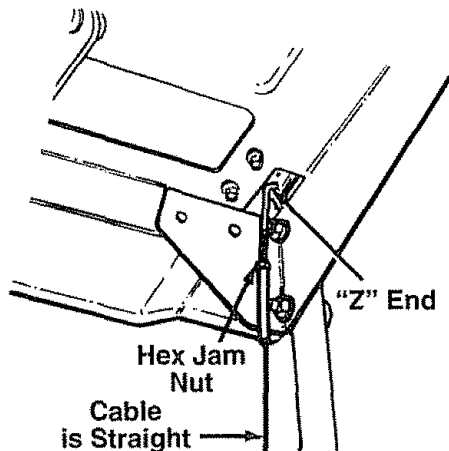

FIGURE 9.—Viewed from underside of handle panel.

WARNING: IF CABLE IS TIGHTENED SO THERE IS TENSION ON THE CABLE WITH THE CLUTCH GRIP RELEASED, THE SAFETY FEATURES OF THE SNOW THROWER MAY BE OVERRIDDEN.

- When correct adjustment is reached, tighten the hex nut against the bottom portion of the cable to lock it in position.

ASSEMBLY INSTRUCTIONS

ATTACHING THE LEFT AND RIGHT TRACK CONTROLS

- Remove the screw from the top of the right hand track control. Be careful not to lose the flat weld nut that is inside the control.
- Place the right track control in position underneath the right handle. Secure with screw just removed. See figure 10.
- Secure the left track control in the same manner.

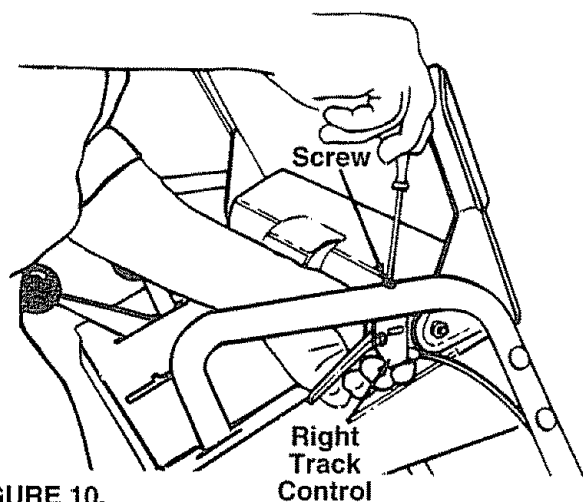

FIGURE 10.

FINAL ADJUSTMENTS

Auger Drive Clutch

To check the adjustment of the auger drive clutch, push forward on the left hand clutch grip (depress the rubber bumper). There should be slack in the cable. Release the clutch grip. The cable should be straight. Make certain you can depress the auger drive clutch grip against the left handle completely.

If necessary, loosen the hex jam nut and thread the cable in or out as necessary. Refer to figure 9. Recheck the adjustment. Tighten the jam nut against the cable when correct adjustment is reached.

Traction Drive Clutch and Shift Lever Adjustment

To check the adjustment of the traction drive clutch and shift lever, tip the snow thrower forward so that it rests on the auger housing. First move the shift lever all the way forward to sixth (6th) position. With the traction drive lever released, turn the snow thrower tracks by hand. They should turn freely. Then engage the traction drive clutch grip and try to turn the tracks. The tracks should not move.

Now release the traction drive clutch grip, and turn the tracks again. Move the shift lever back to the fast reverse position, then all the way forward again. There should be no resistance in the shift lever, and you should be able to turn the tracks by hand.

If you have resistance when moving the shift lever or you are unable to turn the tracks by hand, loosen the lock nut on the traction drive cable and unthread the cable one turn. If you are able to turn the tracks when you engage the traction drive clutch grip, loosen the lock nut on the traction drive cable and thread the cable in one turn. Recheck the adjustment and repeat adjustment as necessary. Tighten the lock nut to secure the cable when correct adjustment is reached.

Adjusting the Skid Shoes

The space between the shave plate and the ground can be adjusted. For close snow removal, place skid shoes in the low position. Use middle or high position when area to be cleared is uneven. See figure 11.

Adjust skid shoes by loosening the four hex nuts and carriage bolts and moving skid shoes to desired position. Make certain the entire bottom surface of skid shoe is against the ground to avoid uneven wear on the skid shoes. Retighten nuts and bolts securely.

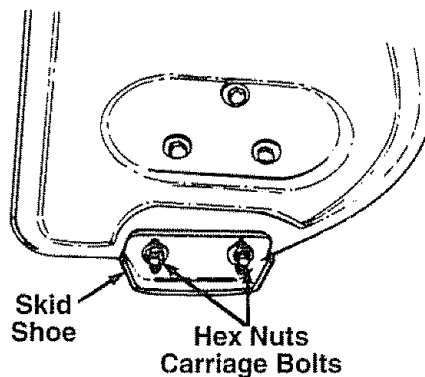

FIGURE 11.

OPERATION

KNOW YOUR SNOW THROWER

READ THIS OWNER'S MANUAL AND SAFETY RULES BEFORE OPERATING YOUR SNOW THROWER. Compare the illustrations with your snow thrower to familiarize yourself with the location of various controls and adjustments. Save this manual for future reference.

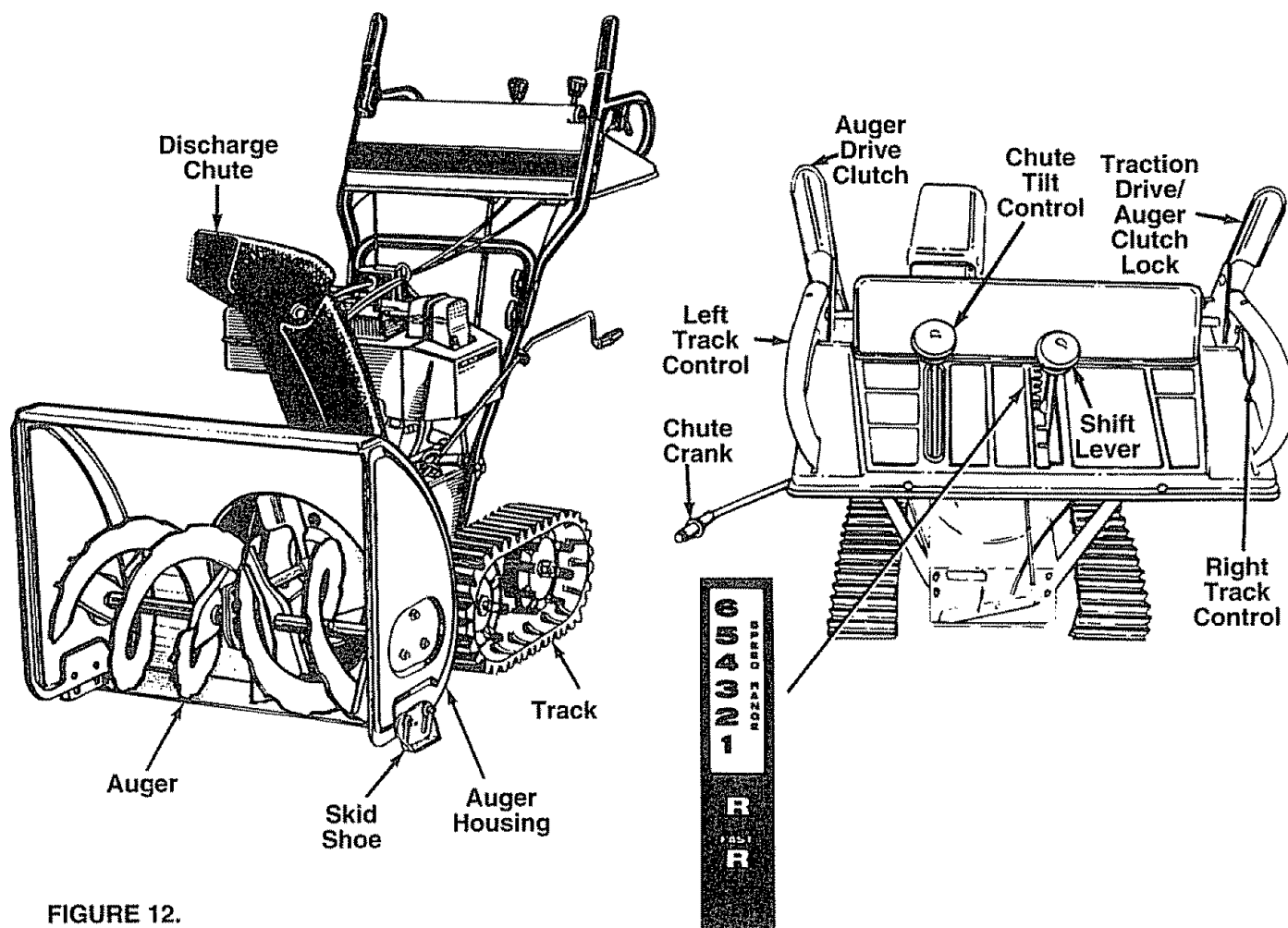

FIGURE 12.

MEETS ANSI SAFETY REQUIREMENTS

Sears snow throwers conform to the safety standards of the American National Standards Institute.

OPERATING CONTROLS

SHIFT LEVER (See figures 12)

The shift lever is located in the center of the handle panel. The shift lever may be moved into one of eight positions. Run engine with throttle in the fast position. Use the shift lever to determine ground speed.

Forward—one of six speeds. Position number one (1) is the slowest. Position number six (6) is the fastest.

Reverse—two reverse (R) speeds. "R" closest to the operator (all the way back) is the faster of the two.

AUGER DRIVE CLUTCH (See figure 12)

The auger drive clutch is located on the left handle. Squeeze the auger drive clutch against the handle to engage the augers. Release to stop the snow throwing action. (**Traction drive clutch must also be released.**)

OPERATION

TRACTION DRIVE/AUGER CLUTCH LOCK (See figure 12)

The traction drive clutch is located on the right handle. Squeeze the traction drive clutch to engage the wheel drive. Release to stop.

This same lever also locks the auger clutch so you can turn the chute crank without interrupting the snow throwing process. If the auger drive clutch is engaged with the traction drive clutch engaged, the operator can release the auger drive clutch (on the left handle) and the augers will remain engaged. Release the traction drive clutch to stop both the augers and wheel drive (**auger drive clutch must also be released**).

CHUTE CRANK (See figure 12)

The chute crank is located on left hand side of the snow thrower.

To change the direction in which snow is thrown, turn chute crank as follows:

1. Crank clockwise to discharge to the left.
2. Crank counterclockwise to discharge to the right.

LEFT AND RIGHT TRACK CONTROLS

The left and right track controls are located on the underside of the handles and are used to assist in steering your snow thrower. See figure 12. Squeeze the right track control when turning right, squeeze the left control when turning left. Operate your snow thrower in open areas until you become familiar with these controls.

CHUTE TILT CONTROL

The distance snow is thrown can be adjusted by adjusting the angle of the chute assembly. Move the chute tilt control forward to decrease the distance, toward the rear to increase. See figure 12.

TRACK LOCK LEVER

The track lock lever is located on the right side of the snow thrower and is used to select the position of the housing and the method of track operation. See figure 13. Move the lever to the right, then forward or backward to one of the three positions.

Transport—Raises the front end of the snow thrower for easy transport. May also be used on gravel driveways to clear snow and leave gravel undisturbed.

Normal Snow—Allows the tracks to be suspended independently for continuous ground contact.

Packed Snow—Locks the front end of the snow thrower down to the ground for hard-packed or icy snow conditions.

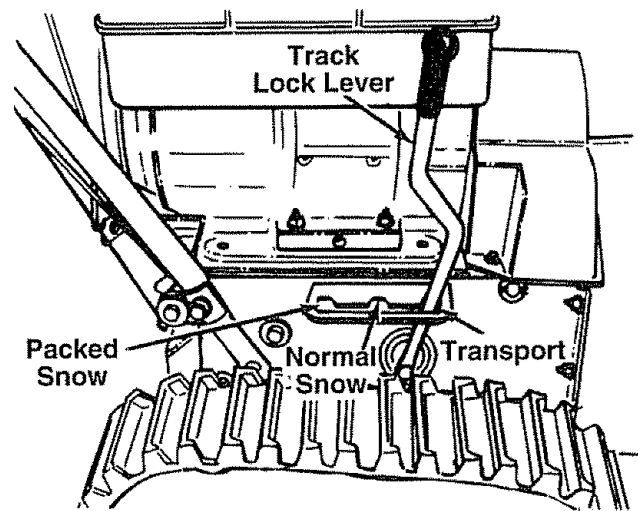

FIGURE 13.

THROTTLE CONTROL (See figure 14)

The throttle control is located on the engine. It regulates the speed of the engine.

SAFETY IGNITION SWITCH (See figure 14)

The ignition key must be inserted in the switch before the unit will start. Remove the ignition key when snow thrower is not in use.

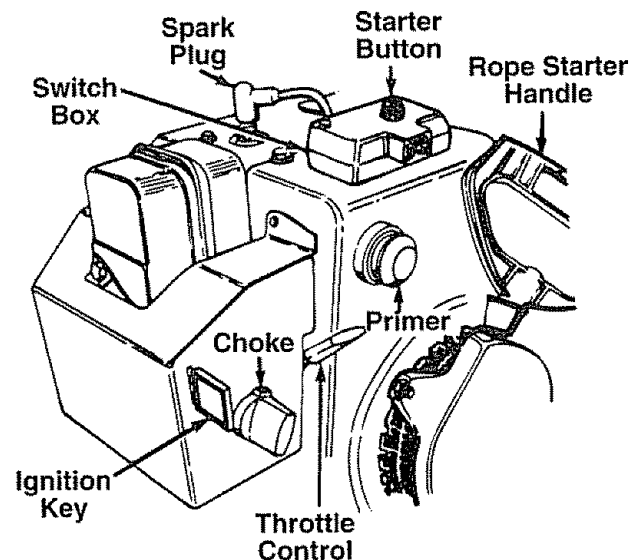

FIGURE 14.

HEAD LAMP (8 H.P. Only)

The head lamp is on whenever the engine is running.

OPERATION

BEFORE USING YOUR SNOW THROWER, AGAIN REFER TO THE "SAFETY RULES" AS SHOWN ON PAGE 2 OF THIS MANUAL. ALWAYS BE CAREFUL.



The operation of any snow thrower can result in foreign objects being thrown into the eyes, which can result in severe eye damage. Always wear safety glasses or eye shields before starting power tool operation or while performing any adjustments or repairs. We recommend Wide Vision Safety Mask for over spectacles or standard safety glasses available at Sears Retail or Catalog Stores.

TO STOP ENGINE

- Remove the ignition key from the carburetor cover on the engine (do not turn). See figure 14.
- Disconnect spark plug wire and move away from spark plug to prevent accidental starting while equipment is unattended.

HOW TO USE YOUR SNOW THROWER

The snow thrower is propelled by the two tracks.

TO ENGAGE DRIVE

- With the engine running near top speed, move shift lever into one of the six FORWARD positions or two REVERSE positions. Select a speed appropriate for the snow conditions that exist. Use the slower speeds until you are familiar with the operation of the snow thrower.
- Squeeze the left hand auger drive clutch to engage it.
- While the left hand auger drive clutch is engaged, engage the right hand traction drive/auger clutch lock.
- Release the left hand auger drive clutch only. The interlock mechanism should keep the left hand auger drive clutch engaged until the right hand traction drive/auger clutch lock is released. Release it and the drive motion will stop.

NOTE: NEVER move shift lever without first releasing the drive clutch.

- Set the track lock lever in one of the three positions: transport, normal snow or packed snow. See figure 13.

DISCHARGE CHUTE

The direction snow is thrown can be changed by turning the chute control crank.

- Turn clockwise to discharge to the left.
- Turn counterclockwise to discharge to the right.

The distance snow is thrown can be changed by adjusting the upper chute tilt control.

- Move the tilt control forward to decrease the distance.

- Move the tilt control to the rear to increase the distance.

BEFORE STARTING

OIL

- Only use high quality detergent oil rated with API service classification SF or SG. Use SAE 5W-30 oil.
- SAE 10W is an acceptable substitute. (Do not use 10W-40).
- Oil sump capacity:
5 H.P. Engine 1-1/4 pints (19 ounces)
8 H.P. Engine 1-5/8 pints (26 ounces)
- Maintain oil level between "FULL" and "ADD" marks on dipstick.
- Remove oil fill plug and dipstick.
- Wipe dipstick clean, insert it into oil fill hole and tighten securely. Remove dipstick. If oil is not up to "FULL" mark on dipstick, add recommended oil. POUR SLOWLY. Wipe dipstick clean each time oil level is checked.

IMPORTANT: DO NOT FILL ABOVE "FULL" MARK ON DIPSTICK.

- Install oil fill plug and dipstick. Tighten securely.

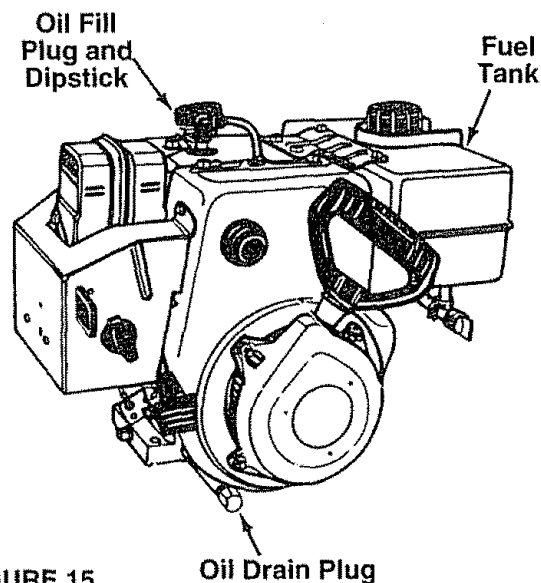

FIGURE 15.

OPERATION

GAS

- Remove fuel cap and fill fuel tank with about 3 quarts of clean, fresh, lead-free grade automotive gasoline. DO NOT use Ethyl or high octane gasoline. Be certain container is clean and free from rust or foreign particles. Never use gasoline that may be stale from long periods of storage in the container. Replace fuel cap.



WARNING: DO NOT FILL CLOSER THAN 1/2 INCH OF TOP OF FUEL TANK TO PREVENT SPILLS AND TO ALLOW FOR FUEL EXPANSION. IF GASOLINE IS ACCIDENTLY SPILLED, MOVE SNOW THROWER AWAY FROM AREA OF SPILL. AVOID CREATING ANY SOURCE OF IGNITION UNTIL GASOLINE VAPORS HAVE DISAPPEARED.

Check the fuel level periodically to avoid running out of gasoline while operating the snow thrower. If the unit runs out of gas, it may be necessary to unclog the unit before it can be restarted. Refer to Service and Adjustment section.

WARNING: EXPERIENCE INDICATES THAT ALCOHOL BLENDED FUELS (CALLED GASOHOL OR USING ETHANOL OR METHANOL) CAN ATTRACT MOISTURE WHICH LEADS TO SEPARATION AND FORMATION OF ACIDS DURING STORAGE. ACIDIC GAS CAN DAMAGE THE FUEL SYSTEM OF AN ENGINE WHILE IN STORAGE. TO AVOID ENGINE PROBLEMS, THE FUEL SYSTEM SHOULD BE EMPTIED OR TREATED WITH FUEL STABILIZER BEFORE STORAGE FOR 30 DAYS OR LONGER. USE FRESH FUEL NEXT SEASON. SEE "STORAGE" SECTION FOR ADDITIONAL INFORMATION.

NEVER USE ENGINE OR CARBURETOR CLEANER PRODUCTS IN THE FUEL TANK OR PERMANENT DAMAGE MAY OCCUR.

TO START ENGINE

USING THE ELECTRIC STARTER

- Make certain the auger control handle is disengaged (released).
- Insert ignition key into ignition switch. Do not turn.
- To start a cold engine, move choke lever to ON position. If you are starting an engine which has already been run for a few minutes, do not choke.

- To start a cold engine, push primer button one time. Use a firm push. This step is not necessary when starting an engine which has been run for a few minutes.
- Connect power cord to plug on snow thrower, then to a three-hole, grounded 120-volt AC household outlet.



WARNING: ALWAYS CONNECT POWER CORD TO PLUG ON SNOW THROWER FIRST, THEN PLUG THE OTHER END IN THE HOUSEHOLD OUTLET. WHEN DISCONNECTING, ALWAYS UNPLUG FROM THE HOUSEHOLD OUTLET FIRST.

- Push starter button to engage starter motor and crank engine.

IMPORTANT: THIS ELECTRIC STARTER IS NOT EQUIPPED WITH A THERMAL CUTOUT SWITCH. DO NOT CRANK ENGINE FOR MORE THAN A TOTAL OF 20 SECONDS WITHOUT ALLOWING ELECTRIC STARTER TO COOL DOWN FOR 10 MINUTES, OR SEVERE DAMAGE TO ELECTRIC STARTER CAN RESULT.

NOTE: If the starter motor runs but the engine does not turn over, the starter gear is apparently covered with ice and frozen. Place the unit in a warm atmosphere until the gear is free and the starter will engage.

- After engine starts, release starter button. Allow the engine to warm up for a few minutes. Then move choke gradually to OFF position. If engine falters, return to ON position, then slowly move to OFF position.
- Unplug the power cord from the household outlet, then from the plug on snow thrower.

USING THE RECOIL STARTER

- Make certain auger control handle is disengaged (released).
- Insert ignition key into ignition switch. Do not turn.
- To start a cold engine, move choke lever to ON position. If you are starting an engine which has already been run for a few minutes, do not choke.
- To start a cold engine, push primer button two or three times. Use a firm push. This step is not necessary when starting an engine which has been run for a few minutes.

OPERATION

NOTE: If the temperature is below 15°F., additional priming may be necessary for initial start only.

- Grasp starter handle and pull rope out slowly, until it pulls slightly harder. Let rope rewind slowly.
- Pull starter handle rapidly. Keep a firm hold on the handle and allow it to rewind slowly. Do not allow handle to snap back.
- If engine fails to start after 3 pulls on the starter handle, prime engine two times and pull starter handle again.
- After engine starts and begins to operate evenly, move choke lever gradually to OFF position. If engine falters, return to ON position, then slowly move to OFF position.



WARNING: TEMPERATURE OF MUFFLER AND SURROUNDING AREAS MAY EXCEED 150°F. AVOID THESE AREAS.

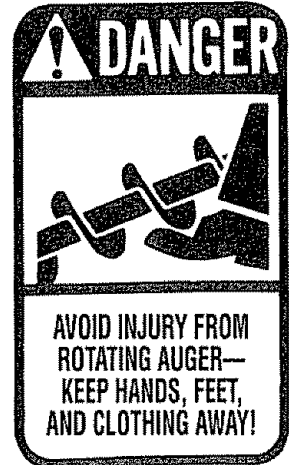
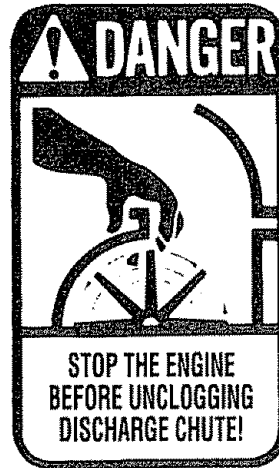

OPERATING TIPS

- Use your snow thrower to remove fresh snow before it is packed down by footprints or tire tracks.
- Discharge snow in the direction the wind is blowing whenever possible.
- Slightly overlap each previous swath.
- Snow up to about an 8 inch depth can be removed easily by walking at a moderate rate. Slow your pace for wet or deep snow.
- Run engine for a few minutes before stopping to help dry off any moisture on the engine.

CUSTOMER RESPONSIBILITIES

MAINTENANCE SCHEDULE FILL IN DATES AS YOU COMPLETE REGULAR SERVICE		BEFORE EACH USE / AFTER EACH USE / FIRST FIVE HOURS / EVERY 25 HOURS / EVERY 50 HOURS / BEFORE STORAGE						SERVICE DATES								
PRODUCT	Oil Pivot Points				√			√								
	Clean Snow Thrower		√						√							
	Shave Plate				√											
	Skid Shoes				√											
	V-Belts						√									
	Friction Wheel				√											
ENGINE	Check Engine Oil	√														
	Change Engine Oil			√	√											
	Service Air Cleaner				√											
	Spark Plug				√				√							
	Muffler						√									

√ CHECK

GENERAL RECOMMENDATIONS

WARNING: ALWAYS STOP THE ENGINE AND DISCONNECT THE SPARK PLUG WIRE BEFORE PERFORMING ANY MAINTENANCE OR ADJUSTMENTS.

- Periodically check all fasteners and be sure they are tight.
- Follow the Maintenance Schedule above.

LUBRICATION

Gear Shaft

Lubricate the gear shaft with grease at least once a season or after every 25 hours of operation.

IMPORTANT: Keep all grease and oil off of the friction wheel and drive plate.

Shifting Mechanism

Lubricate the shifting mechanism and pivot points on the shift rod with engine oil at least once a season or after every 25 hours of operation.

Traction Drive/Auger Clutch Lock

The cams on the ends of the control rods which interlock the traction drive and auger drive clutches must be lubricated at least once a season or every twenty-five hours of operation with grease. The cams can be accessed beneath the handle panel.

Gear Case

The gear case is lubricated with grease at the factory and does not require checking. If disassembled for any reason, lubricate with 2 ounces of Shell Alvania grease, part number 737-0168.

Bearings

Lubricate the auger bearings, wheel bearings and the bearings on the side of the frame once a season with light oil.

CUSTOMER RESPONSIBILITIES

AUGERS

The augers are secured to the spiral shaft with two hex bolts and hex lock nuts. See figure 16. If you hit a foreign object or ice jam, the snow thrower is designed so that the hex bolts will shear.

If the augers will not turn, check to see if the hex bolts have sheared. Two replacement hex bolts and hex lock nuts have been provided with the snow thrower. For future use, order part number 710-0890 (hex bolt 5/16-18 x 1.5" long) and 712-0429 (hex insert lock nut 5/16-18 thread).

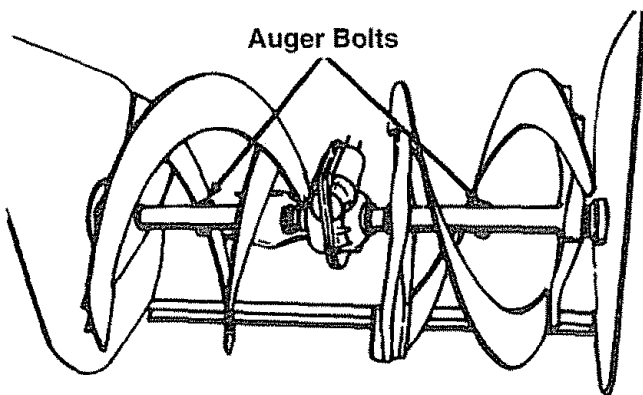

FIGURE 16.

ENGINE ENGINE OIL

- Only use high quality detergent oil rated with API service classification SF or SG. Use SAE 5W-30 oil.
- SAE 10W is an acceptable substitute. (Do not use 10W-40).
- Oil sump capacity:
5 H.P. Engine 1-1/4 pints (19 ounces)
8 H.P. Engine 1-5/8 pints (26 ounces)
- Maintain oil level between "FULL" and "ADD" marks on dipstick.
- Remove oil fill plug and dipstick.
- Wipe dipstick clean, insert it into oil fill hole and

tighten securely. Remove dipstick. If oil is not up to "FULL" mark on dipstick, add recommended oil. POUR SLOWLY. Wipe dipstick clean each time oil level is checked.

IMPORTANT: DO NOT FILL ABOVE "FULL" MARK ON DIPSTICK.

- Install oil fill plug and dipstick, tighten securely.

To Drain Oil:

- Drain oil while engine is warm.
 - a. Remove oil drain plug. Refer to figure 15. Catch oil in a suitable container.
 - b. When engine is drained of all oil, replace drain plug securely.
- Refill with fresh oil. Refer to before starting in the operation section.
- Replace dipstick.

SPARK PLUG

The spark plug should be cleaned and the gap reset to .030" at least once a season or every 50 hours of operation. See figure 17. Spark plug replacement is recommended at the start of each season. Refer to engine parts list for correct spark plug type.

NOTE: Do not sandblast spark plug. Spark plug should be cleaned by scraping or wire brushing and washing with a commercial solvent.

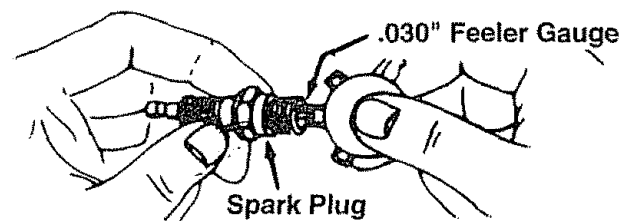

FIGURE 17.

STORAGE

Prepare your snow thrower for storage at the end of the season or if the unit will not be used for 30 days or more.



WARNING: NEVER STORE MACHINE WITH FUEL IN THE FUEL TANK INSIDE OF BUILDING WHERE FUMES MAY REACH AN OPEN FLAME OR SPARK, OR WHERE IGNITION SOURCES ARE PRESENT SUCH AS HOT WATER AND SPACE HEATERS, FURNACES, CLOTHES DRYERS, STOVES, ELECTRIC MOTORS, ETC.

NOTE: A yearly check-up by your local Sears Service Center is a good way to make certain your snow thrower will provide maximum performance for the next season.

SNOW THROWER

- Clean the snow thrower thoroughly.
- Wipe unit with an oiled rag to prevent rust (use a light oil or silicone).

ENGINE

IMPORTANT: IT IS IMPORTANT TO PREVENT GUM DEPOSITS FROM FORMING IN ESSENTIAL FUEL SYSTEM PARTS SUCH AS CARBURETOR, FUEL FILTER, FUEL HOSE, OR TANK DURING STORAGE. ALSO, EXPERIENCE INDICATES THAT ALCOHOL BLENDED FUELS (CALLED GASOHOL OR USING ETHANOL OR METHANOL) CAN ATTRACT MOISTURE WHICH LEADS TO SEPARATION AND FORMATION OF ACIDS DURING STORAGE. ACIDIC GAS CAN DAMAGE THE FUEL SYSTEM OF AN ENGINE WHILE IN STORAGE.

- Drain the fuel tank.
- Start the engine and let it run until the fuel lines and carburetor are empty.
- Never use engine or carburetor cleaner products in the fuel tank or permanent damage may occur.
- Use fresh fuel next season.

NOTE: Fuel stabilizer is an acceptable alternative in minimizing the formation of fuel gum deposits during storage. Add stabilizer to gasoline in fuel tank or storage container. Always follow the mix ratio found on stabilizer container. Run engine at least 10 minutes after adding stabilizer to allow the stabilizer to reach the carburetor. Do not drain the gas tank and carburetor if using fuel stabilizer.

- Drain all the oil from the crankcase (this should be done after the engine has been operated and is still warm) and refill the crankcase with fresh oil.
- If you have drained the fuel tank, protect the inside of the engine as follows. Remove spark plug, pour approximately 1/2 ounce (approximately one tablespoon) of engine oil into cylinder and crank slowly to distribute oil. Replace spark plug.

OTHER

- Do not store gasoline from one season to another.
- Replace your gasoline can if your can starts to rust. Rust and/or dirt in your gasoline will cause problems.
- Store unit in a clean, dry area. Do not store next to corrosive materials, such as fertilizer.

NOTE: If storing in an unventilated or metal storage shed, be certain to rustproof the equipment by coating with a light oil or silicone.

SERVICE & ADJUSTMENT



WARNING: ALWAYS STOP ENGINE AND DISCONNECT SPARK PLUG WIRE AND MOVE IT AWAY FROM SPARK PLUG BEFORE PERFORMING ANY ADJUSTMENTS OR REPAIRS.

SHAVE PLATE AND SKID SHOES

- The shave plate and skid shoes on the bottom of the snow thrower are subject to wear. They should be checked periodically and replaced when necessary.

- To remove skid shoes, remove the four carriage bolts, belleville washers and hex nuts which attach them to the snow thrower. Reassemble new skid shoes with the four carriage bolts, belleville washers (cupped side goes against skid shoes) and hex nuts. Make certain the skid shoes are adjusted to be level.
- To remove shave plate, remove the carriage bolts, belleville washers and hex nuts which attach it to the snow thrower housing. Reassemble new shave plate, making sure heads of the carriage bolts are to the inside of the housing. Tighten securely.

SERVICE & ADJUSTMENT

BELT REMOVAL AND REPLACEMENT

 **WARNING: DISCONNECT THE SPARK PLUG WIRE FROM THE SPARK PLUG AND GROUND.**

To remove and replace either the rear or front auger drive belt, proceed with the following instructions.

- Disconnect the chute crank at the chute assembly by removing the cotter pin and flat washer.
- Remove the plastic belt cover on the front of the engine by removing two self-tapping screws. See figure 18.

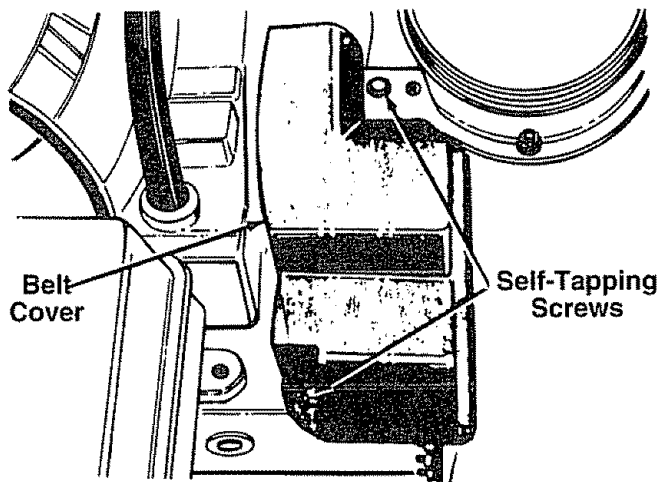

FIGURE 18.

- Unthread the bottom of the auger cable from the top of the cable, leaving the hex nut in place.
- Remove the six hex bolts, lock washers and hex nuts which attach the auger housing assembly to the frame. See figure 19.
- Separate the housing from the frame assembly by standing in the operating position and lifting up on the handles. The frame and housing will separate, and the rear auger drive belt will come off the pulleys. See figure 20.
- To remove the front auger drive belt, push the idler pulley to the left, and lift front auger drive belt from the front auger pulley. See figure 21. Replace both auger drive belts by following instructions in reverse order.

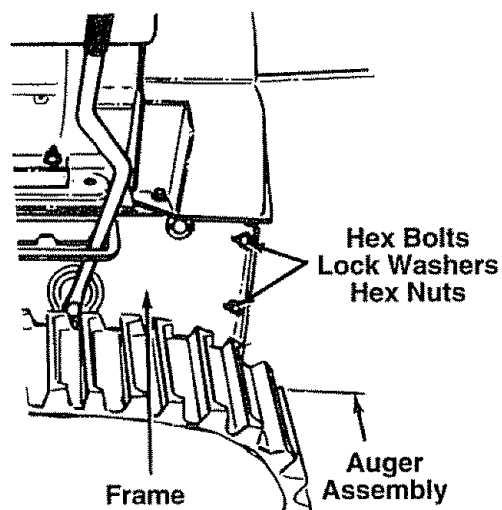

FIGURE 19.

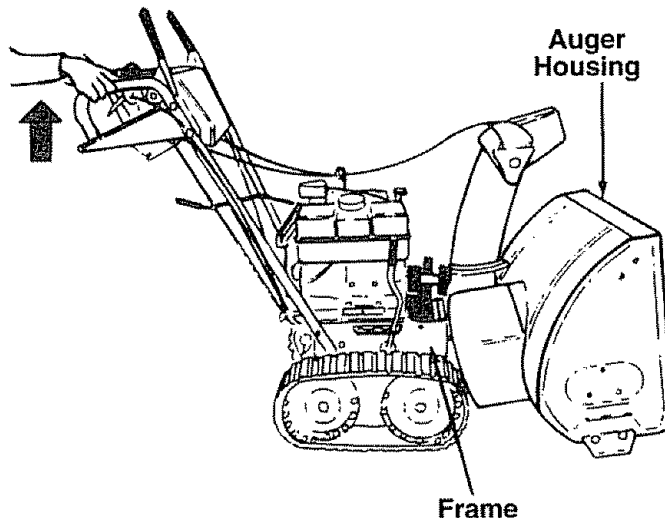

FIGURE 20.

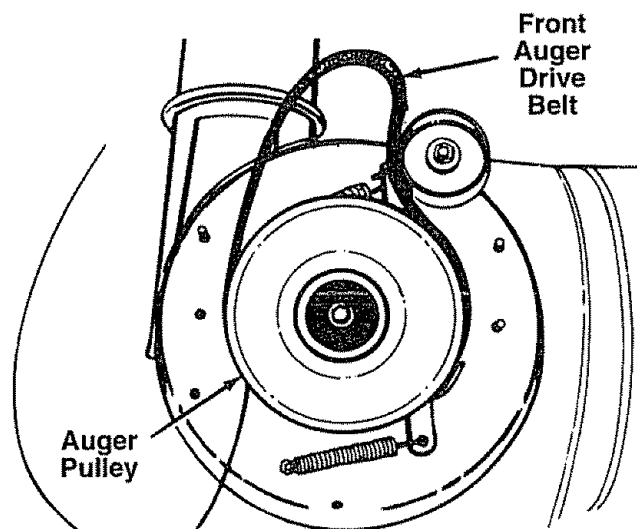

FIGURE 21.

SERVICE & ADJUSTMENT

- If a replacement drive belt is needed, follow previous instructions. Pull idler pulley up and lift belt off friction wheel disc. See figure 22. Reassemble in reverse order.

NOTE: When reassembling the two halves of the unit, the auger drive cable must be routed through the cable roller guides as shown in figure 22.

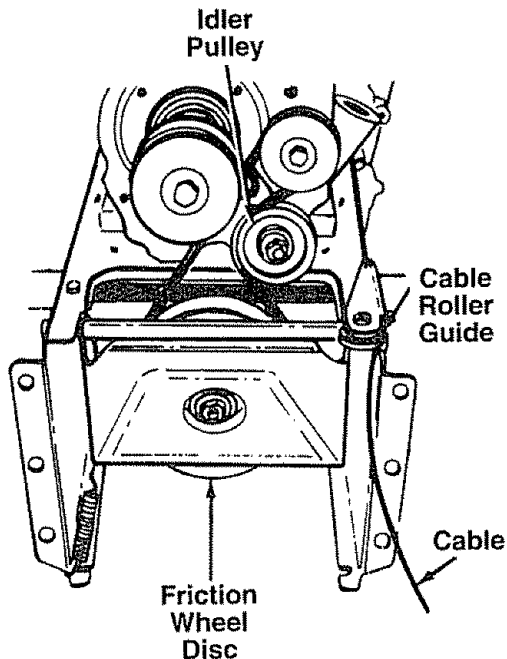

FIGURE 22.

CHANGING THE FRICTION WHEEL RUBBER

The rubber on the friction wheel is subject to wear and should be checked after 25 hours of operation, and periodically thereafter. Replace the friction wheel rubber if any signs of wear or cracking are found.

- Drain the gasoline from the snow thrower, or place a piece of plastic under the gas cap.
- Tip the snow thrower up and forward, so that it rests on the housing.
- Remove four self-tapping screws from the frame cover underneath the snow thrower.
- Remove the gear shaft from the unit by removing the bolts, lock washers and flat washers from each side of the frame. See figure 23. Hold the friction wheel assembly, and slide the gear shaft out of the unit toward the right hand side. Refer to figure 24.

- Remove the six screws from the friction wheel assembly (three from each side). Remove the friction wheel rubber from between the friction wheel plate.
- Reassemble new friction wheel rubber to the friction wheel assembly, tightening the six screws in rotation and with equal force.
- Slide the friction wheel assembly up onto the shift mechanism as shown in figure 24, and slide the gear shaft back into the unit. Reassemble in reverse order.

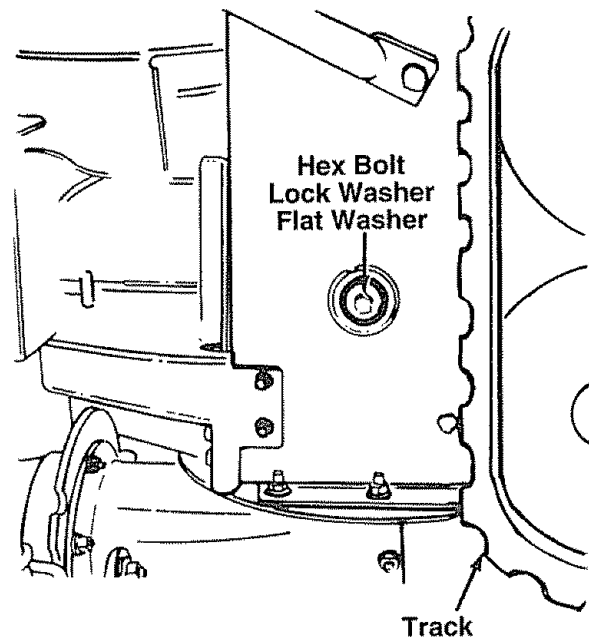

FIGURE 23.

TRACTION DRIVE CLUTCH ADJUSTMENT

Refer to the Final Adjustment section of the Assembly Instructions to adjust the traction drive clutch. If you are uncertain that you have reached the correct adjustment, the adjustment can be physically checked as follows.

With the snow thrower tipped forward (be certain to drain the gasoline or place plastic film under the gas cap if the snow thrower has already been operated), remove the frame cover underneath the snow thrower by removing four self-tapping screws. With the traction drive clutch released, there must be clearance between the friction wheel and the drive plate in all positions of the shift lever. With the traction drive clutch engaged, the friction wheel must contact the drive plate. See figure 24.

SERVICE & ADJUSTMENT

If adjustment is necessary, loosen the lock nut on the traction drive cable and thread the cable in or out as necessary. Tighten the lock nut to secure the cable when correct adjustment is reached. Reassemble the frame cover.

NOTE: If you placed plastic under the gas cap, be certain to remove it.

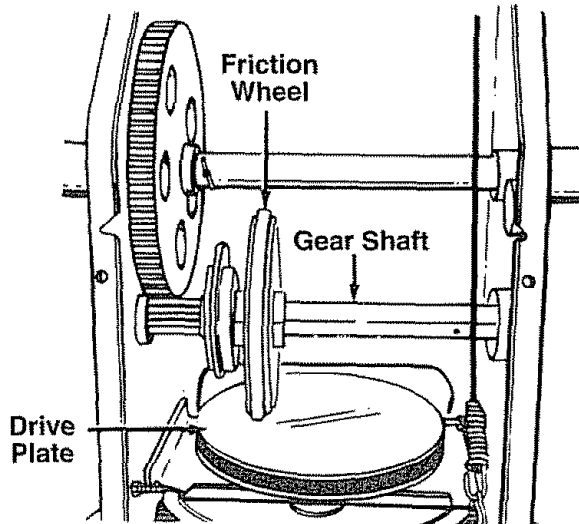

FIGURE 24.

AUGER CLUTCH ADJUSTMENT

To adjust the auger clutch, refer to Final Adjustment section of Assembly Instructions.

SHIFT ROD ADJUSTMENT

To adjust the shift rod, remove the hairpin clip and flat washer which secure the shift rod to the shift arm assembly. Refer to figure 8. Adjust as specified in Assembly Instructions.

CARBURETOR ADJUSTMENT



WARNING: IF ANY ADJUSTMENTS ARE MADE TO THE ENGINE WHILE THE ENGINE IS RUNNING (E.G. CARBURETOR), KEEP CLEAR OF ALL MOVING PARTS. BE CAREFUL OF HEATED SURFACES AND MUFFLER.

Minor carburetor adjustment may be required to compensate for differences in fuel, temperature, altitude or load.

Never attempt to change maximum engine speed. It is pre-set at the factory and should be changed only by a qualified service technician who has the necessary equipment.

5 H.P. ENGINE

Idle Speed Adjustment. This screw is located on top of the carburetor and contacts the throttle. To initially pre-adjust this speed, back out the screw, then turn in until the screw just touches the throttle lever, then turn screw in 1 turn. When the engine is run, the final idle R.P.M. can be adjusted with a tachometer.

Idle and Main Adjustment. Turn these adjustment screws in finger tight, then back them out to the pre-set figure on the chart.

TECUMSEH CARBURETOR PRE-SETS

ENGINE MODELS	MAIN PRE-SET	IDLE PRE-SET
5 H.P.	1-1/4	1

Final Carburetor Adjustments

Allow engine to warm up to a normal running temperature. With engine running at maximum recommended R.P.M., loosen main adjustment screw until engine starts to cut out. Then turn screw opposite direction until engine starts to cut out. Note the number of turns from one extreme to the other. Loosen screw to a point midway between the extremes.

After the main system is adjusted, move the speed control lever to the idle position and follow the same procedure for adjusting the idle system.

Test the engine by running it under a normal load. The engine should respond to load pick-up immediately. An engine that "dies" is too lean.

An engine which ran rough before picking up the load, is adjusted too rich.

If adjustment seems too "touchy" check float for proper setting and for sticking.

8 H.P. ENGINE

Preset the carburetor by turning both idle and main adjustment screw closed (clockwise) fingertight. Open the main adjustment screw 2 turns (counterclockwise) and the idle adjustment screw 1-3/4 turns.

Generally, the engine will perform well with these settings. If further adjustment is required, perform the following adjustments with the engine running and fully warmed up.

With speed control lever at idle or slow speed, turn the idle adjustment screw slowly, clockwise 1/8 turn at a time until the lean drop off point is reached. (The engine will miss and run erratically due to lack of fuel.) Now turn the screw counterclockwise 1/4 to 3/8 turn from that position. This will be the best setting.

TROUBLE SHOOTING GUIDE

Trouble	Possible Cause(s)	Corrective Action
Engine fails to start	<ol style="list-style-type: none"> 1. Fuel tank empty, or stale fuel. 2. Blocked fuel line. 3. Key not in switch on engine. 4. Spark plug wire disconnected. 5. Faulty spark plug. 	<ol style="list-style-type: none"> 1. Fill tank with clean, fresh gasoline. 2. Clean fuel line. 3. Insert key. 4. Connect wire to spark plug. 5. Clean, adjust gap or replace.
Engine runs erratic	<ol style="list-style-type: none"> 1. Unit running on CHOKE. 2. Blocked fuel line or stale fuel. 3. Water or dirt in fuel system. 4. Carburetor out of adjustment. 	<ol style="list-style-type: none"> 1. Turn choke knob to OFF position. 2. Clean fuel line; fill tank with clean fresh gasoline. 3. Use carburetor bowl drain to drain fuel tank. Refill with fresh fuel. 4. Adjust carburetor. See separate engine manual.
Loss of power	<ol style="list-style-type: none"> 1. Spark plug wire loose. 2. Gas cap vent hole plugged. 	<ol style="list-style-type: none"> 1. Connect and tighten spark plug wire. 2. Remove ice and snow from cap. Be certain vent hole is clear.
Engine overheats	<ol style="list-style-type: none"> 1. Engine oil level low. 2. Carburetor not adjusted properly. 	<ol style="list-style-type: none"> 1. Fill crankcase with proper oil. 2. Adjust carburetor. See separate engine manual.
Excessive vibration	Loose parts or damaged impeller.	Stop engine immediately and disconnect spark plug wire. Tighten all bolts and nuts. Make all necessary repairs. If vibration continues, have unit serviced by Sears Service Center.
Hard to shift, or will not shift	Shift rod misadjusted.	Readjust shift rod. See Adjustment section of this manual.
Unit fails to propel itself	<ol style="list-style-type: none"> 1. Incorrect adjustment of drive clutch. 2. Drive belt loose or damaged. 	<ol style="list-style-type: none"> 1. Adjust drive clutch. Refer to Adjustment section. 2. Replace drive belt. Refer to Maintenance section.
Unit fails to discharge snow	<ol style="list-style-type: none"> 1. Auger shear bolt broken. 2. Discharge chute clogged. 3. Foreign object lodged in auger. 4. Incorrect adjustment of auger drive clutch 5. Auger drive belt loose or damaged. 	<ol style="list-style-type: none"> 1. Replace auger shear bolt. Refer to Maintenance section. 2. Stop engine immediately and disconnect spark plug wire. Clean discharge chute and inside of auger housing. 3. Stop engine immediately and disconnect spark plug wire. Remove object from auger. 4. Adjust auger clutch. Refer to Adjustment section. 5. Replace auger drive belt. Refer to Maintenance section.

NOTE: For repairs beyond the minor adjustments listed above, please contact your nearest Sears Service Center.

SEARS CRAFTSMAN 5 AND 8 H.P. SNOW THROWERS MODEL NOS. 247.885550
247.885680

Repair Parts

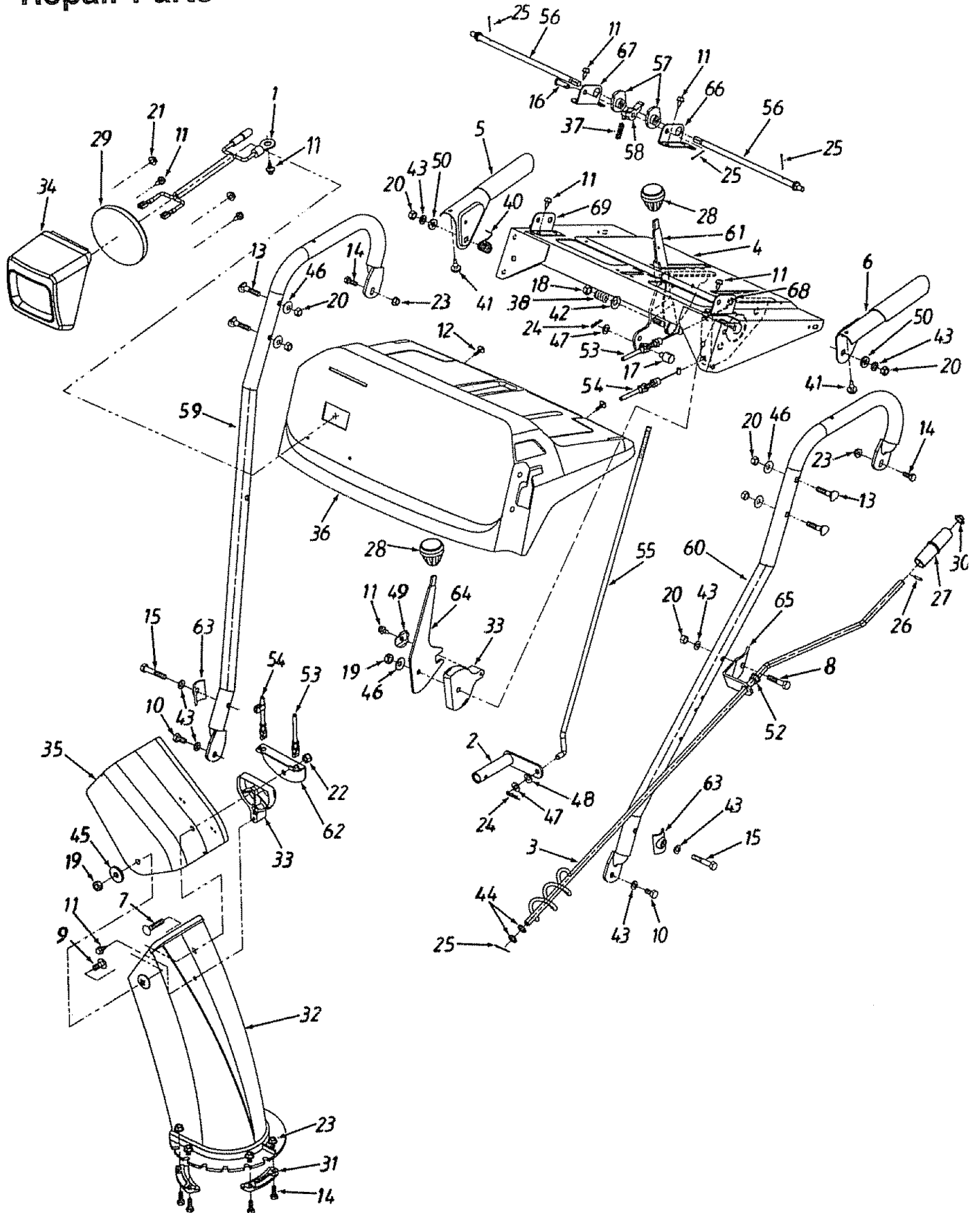

**SEARS CRAFTSMAN 5 AND 8 H.P. SNOW THROWERS MODEL NOS. 247.885550
247.885680**

Repair Parts

KEY NO.	PART NO.	DESCRIPTION	KEY NO.	PART NO.	DESCRIPTION
1	629-0058	Light Harness†	34	731-1317	Headlight Bezel†
2	684-0008	Shift Arm Ass'y.	35	731-1320	Upper Chute
3	684-0022	Chute Crank Ass'y.	36	731-1327	Handle Panel (247.885550)
4	684-0032A	Handle Panel Ass'y.		731-1580	Handle Panel (247.885680)
5	684-0036	Engagement Handle Ass'y.— R.H.	37	732-0145	Compression Spring 1" Lg.
			38	732-0193	Compression Spring .88" Lg.
6	684-0037	Engagement Handle Ass'y.— L.H.	40	732-0746	Torsion Spring .8" Lg.
			41	735-0199A	Rubber Bumper
7	710-0262	Carriage Bolt 5/16-18 x 1.5" Lg.	42	736-0105	Bell.-Wash. .38" I.D. x .88"
8	710-0442	Hex Bolt 5/16-18 x 1.5" Lg.*	43	736-0119	L-Wash. 5/16" I.D.*
9	710-0451	Carriage Bolt 5/16-18 x .75" Lg.	44	736-0140	Fl.-Wash..385" x .62" O.D.
10	710-0538	Hex L-Bolt 5/16-18 x .62" Lg.	45	736-0231	Washer .344" x 1.125" O.D.
11	710-0776A	Hex AB-Tap Scr. 1/4 x .62" Lg.	46	736-0242	Bell.-Wash. .345" I.D. x .88"
12	710-1003	Hex B-Tap Scr. #10-16 x .62" Lg.	47	736-0264	Fl.-Wash. .33" x .63" O.D.
13	710-1250	Curved Carriage Bolt 5/16-18 x 1.0" Lg.	48	736-0271	Spr. Wash. .62" O.D.
			49	736-0506	Washer .286" I.D. x 1.25" O.D.
14	710-3015	Hex Bolt 1/4-20 x .75" Lg.	50	736-0509	Washer .35" I.D. x .72" O.D.
15	710-3180	Hex Bolt 5/16-18 x 1.75" Lg.	52	741-0475	Plastic Bushing .38" I.D.
16	711-0653	Clevis Pin 1" Lg.	53	746-0896	Chute Control Cable w/Clip
17	711-0677	Engagement Ferrule	54	746-0901	Chute Control Cable
18	712-0116	Hex Ins. L-Nut 3/8-24 Thd.	55	747-0798	Shift Rod
19	712-0158	Hex L-Nut 5/16-18 Thd.	56	747-0877	Cam Rod
20	712-0267	Hex Nut 5/16-18 Thd.*	57	748-0362	Handle Lock Cam
21	712-0415	Stud†	58	748-0363	Handle Lock Pawl
22	712-0429	Hex Ins. L-Nut 5/16-18 Thd.	59	749-0908A	Handle—R.H.
23	712-3027	Hex Fl. L-Nut 1/4-20 Thd.	60	749-0909	Handle—L.H.
24	714-0104	Cotter Pin 1.12" Lg.	61	784-0297	Shift Handle
25	714-0507	Cotter Pin 3/32"	62	784-5594	Cable Brkt.
26	715-0138	Roll Pin 1/8" O.D.	63	784-5599	Handle Tab
27	720-0201A	Chute Crank Knob	64	784-5604	Chute Tilt Handle
28	720-0232	Shift Knob	65	784-5678	Chute Crank Brkt. Reinforce.
29	725-1300	Headlight 18 Watt†	66	784-5679	Handle Support Brkt.—L.H.
30	726-0100	Push Cap	67	784-5680	Handle Support Brkt.—R.H.
31	731-0851A	Chute Flange Keeper	68	784-5681	Handle Support Brkt.—L.H.
32	731-1300A	Lower Chute	69	784-5682	Handle Support Brkt.—R.H.
33	731-1313	Cable Guide			

† Model 247.885680 only.

*Common Hardware—May be Purchased Locally.

NOTE: Specifications subject to change without notice or obligation.

SEARS CRAFTSMAN 5 AND 8 H.P. SNOW THROWERS MODEL NOS. 247.885550
 247.885680
Repair Parts

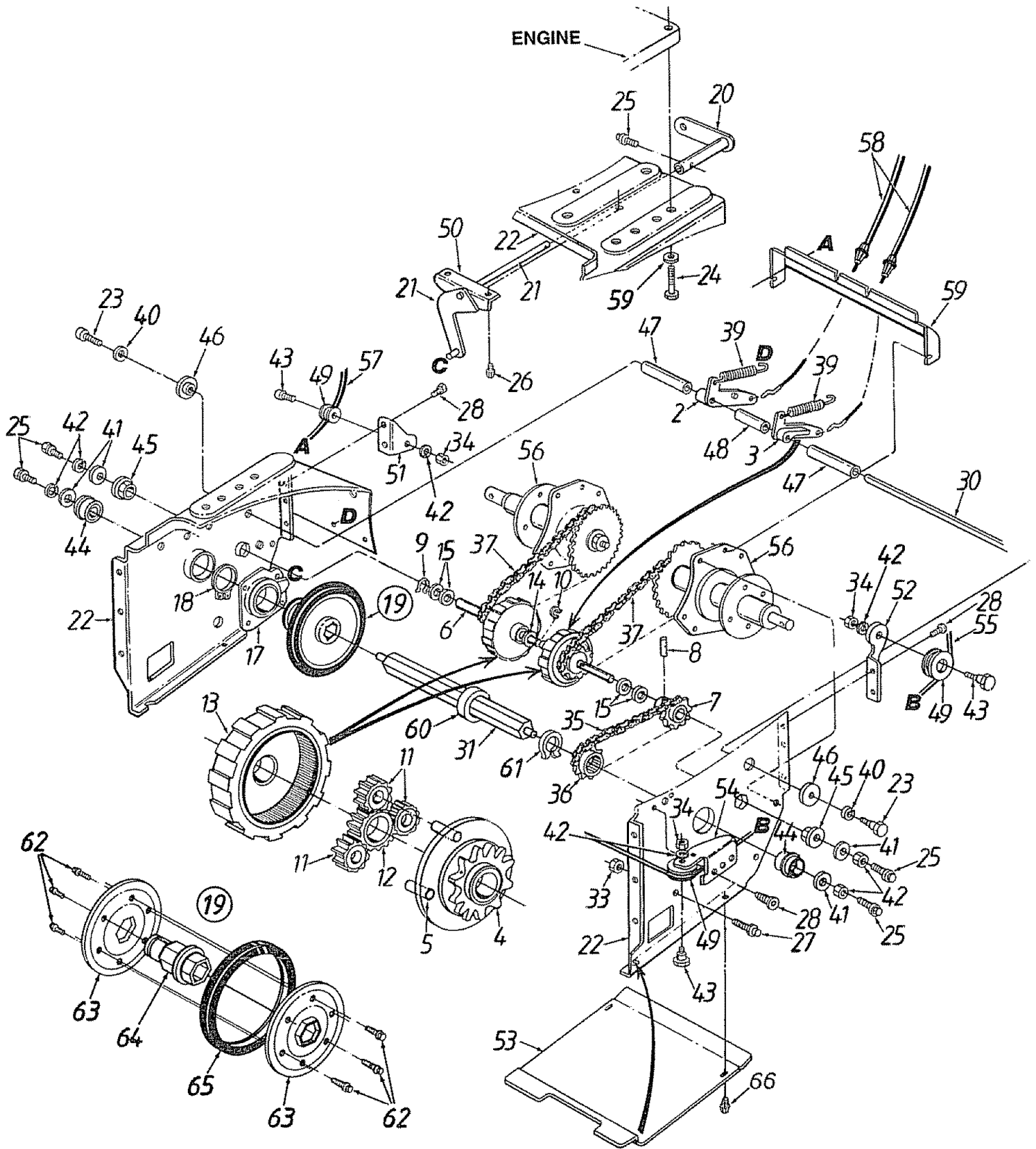

SEARS CRAFTSMAN 5 AND 8 H.P. SNOW THROWERS MODEL NOS. 247.885550

247.885680

Repair Parts

KEY NO.	PART NO.	DESCRIPTION	KEY NO.	PART NO.	DESCRIPTION
2	618-0043	R.H. Dog Ass'y.	34	712-0298	Hex Jam Nut 1/4-20 Thd.
3	618-0044	L.H. Dog Ass'y.	35	713-0267	#420 Chain—1/2 Pitch x 30 Links (Endless)
4	718-0188	Carrier			
5	741-0542	5/16" Dowel Pin	36	713-0415	11 Tooth Sprocket
6	711-0912	Drive Shaft	37	713-0437	#420 Chain—32 Links (Endless)
7	713-0411	12 Tooth Sprocket	39	732-0209	Extension Spring 2.03" Lg.
8	715-0247	Spring Pin 3/16" Dia. x 1" Lg.	40	736-0119	L-Wash. 5/16" I.D.*
9	716-0114	Snap Ring .56" Dia.	41	736-0176	FI-Wash. 1/4" I.D. x .93" O.D.
10	716-0115	Snap Ring .625" Shaft	42	736-0329	L-Wash. 1/4" I.D.*
11	717-1209	12 Tooth Gear	43	738-0870	Shld. Bolt 5/16" Dia. x .35" Lg.
12	717-1210	18 Tooth Gear	44	741-0563	Ball Brg. w/Snap Ring
13	717-1211	Ring Gear	45	741-0597	Hex Flange Bearing
14	736-0336	FI-Wash. 5/8" I.D. x 1" O.D.	46	748-0234	Shld. Spacer .5" Dia. x .27" Lg.
15	736-0502	FI-Wash. .57" I.D. x 1.12" O.D.	47	750-0903	Split Shld. Spacer 2.69" Lg.
17	618-0063	Friction Wheel Brg. Ass'y.	48	750-0904	Split Shld. Spacer 1.77" Lg.
18	716-0185	Retaining Ring 1.375" Dia. Shaft	49	756-0625	Cable Roller
19	684-0042	Friction Wheel	50	784-5590	Shift Brkt. Frame
20	684-0008	Shift Arm Ass'y.	51	784-5644	Drive Cable Roller Brkt.
21	684-0014	Shift Rod Ass'y.	52	784-5646	Auger Cable Guide Brkt.
22	684-0031	Frame Ass'y.	53	784-5648	Frame Cover
23	710-0118	Hex Bolt 5/16-18 x .75" Lg.*	54	784-5658	Front Support Brkt. Guide
24	710-0502A	Hex L-Wash. TT-Tap Scr. 3/8-16 x 1.25" Lg.	55	746-0897	Auger Clutch Cable
25	710-0642	Hex TT-Tap Scr. 1/4-20 x .75" Lg.	56	683-0023	Track Hub Ass'y.
			57	746-0898	Drive Clutch Cable
			58	746-0900	Track Steer Cable w/Trigger
26	710-0653	Hex Wash. Hd. Tap Scr. 1/4-20 x .38" Lg.	59	736-3052	FI-Wash. .406" I.D. x 1" O.D.
			60	750-0920	Spacer 1.02" I.D. x 1.25" O.D.
27	710-0788	Hex Wash. TT-Tap Scr. 1/4-20 x 1" Lg.	61	716-0102	Snap Ring
			62	710-0599	Hex Wash Hd. TT—Tap Screw 1/4-20 x .5" lg.
28	710-1017	Torx Mach. AB-Tap Scr. 1/4 x .62" Lg.	63	784-5677	Friction Plate
30	711-0911	Actuator Shaft	64	718-0240	Friction Wheel Hub
31	711-0944	Drive Shaft	65	735-0243	Friction Wheel Rubber
33	712-0287	Hex Nut 1/4-20 Thd.*	66	710-3007	Hex Wash. Tap Scr. .38" Lg.

*Common Hardware—May be Purchased Locally.

**SEARS CRAFTSMAN 5 AND 8 H.P. SNOW THROWERS MODEL NOS. 247.885550
247.885680**

Repair Parts

KEY NO.	PART NO.	DESCRIPTION	KEY NO.	PART NO.	DESCRIPTION
1	618-0120	Worm Drive Ass'y. Comp. †	36	710-0812	Hex Bolt 1/4-20 x .75" Lg. (Gr. 5)
	618-0121	Worm Drive Ass'y. Comp. ††	37	712-0116	Hex Ins. L-Nut 3/8-24 Thd.
2	719-0292	Reducer Housing—L.H.	38	712-0181	Hex Top L-Nut 3/8-16 Thd.
3	721-0179	Oil Seal	40	712-0291	Hex L-Nut 1/4-20 Thd.
4	741-0339	Flange Bearing .75" I.D.	41	732-0611	Ext. Spring 3.6" Lg.
5	719-0293	Reducer Housing—R.H.	42	736-0167	Fl-Wash. 5/8" I.D. x 1.25"
6	737-3000	Grease Fitting	43	736-0329	L-Wash. 1/4" I.D.*
7	710-0642	Hex TT-Tap Scr. 1/4-20 x .75" Lg.	44	738-0281	Shld. Bolt .625" Dia x .170" Lg.
			45	756-0178	Fl-Idler 2.75" O.D.
8	711-0908	24" Auger Shaft†	46	784-5632	Auger Idler Brkt.
	711-0909	26" Auger Shaft††	47	710-1087	Hex Bolt 5/16-18 x 5/8" Lg.
9	714-0388	#61 Hi-Pro Key 3/16" x 5/8" Dia.	50	741-0309	Ball Bearing .75" I.D.
10	715-0143	Spiral Pin 1.25" Lg.	51	705-5187A	Blower Fan Ass'y.
11	717-0526	Impeller Shaft	52	715-0114	Spiral Pin 1.5" Lg.
12	717-0528	Worm Gear	53	710-0890	Shear Bolt 5/16-18 x 1.5" Lg.
13	718-0186	Thrust Collar	54	712-0158	Hex Cent. L-Nut 5/16-18 Thd.
14	721-0327	Oil Seal	55	736-0188	Fl-Wash. .76" I.D. x 1.49"
15	736-0351	Fl-Wash. .76" I.D. x 1.5" O.D.	56	741-0493A	Flange Bushing .8" I.D.
16	736-0369	Fl-Wash. .5" I.D. x 1" O.D.	57	684-0022	Chute Crank Ass'y.
17	736-0445	Fl-Wash. .76" I.D. x 1.49" O.D.	59	712-0429	Hex Ins. L-Nut 5/16-18 Thd.
19	741-0376	Flange Bearing .75" I.D.	60	714-0507	Cotter Pin 3/32" Dia. x .75"
20	748-0108	Flange Bearing .503" I.D.	64	705-5189	Spiral Ass'y.—L.H.†
21	684-0039	24" Auger Housing Ass'y.†		705-5188	Spiral Ass'y.—R.H. (Not Shown)†
	684-0040	26" Auger Housing Ass'y.††			
22	710-0157	Hex Bolt 5/16-24 x .75" Lg.*		705-5193	Spiral Ass'y.—L.H.††
23	710-0260	Carriage Bolt 5/16-18 x .62" Lg.		705-5192	Spiral Ass'y.—R.H. (Not Shown)††
24	710-0451	Carriage Bolt 5/16-18 x .75" Lg.			
25	712-0123	Hex Nut 5/16-24 Thd.*	65	736-0140	Fl-Wash. .385" I.D. x .62" O.D.
26	712-0267	Hex Nut 5/16-18 Thd.*	68	784-5647	Lower Chute Crank Brkt.
27	736-0119	L-Wash. 5/16" I.D.*	70	05845A	Bearing Housing
28	736-0242	Bell-Wash. .345" I.D. x .88" O.D.	75	741-0300	Plastic Bearing w/Flats
29	784-5580	Slide Shoe	76	05931	Bearing Housing
30	784-5581	24" Shave Plate†	78	684-0045	Plate Reinforcement Ass'y.—L.H.
	784-5579	26" Shave Plate††			
31	710-0286	Truss Mach. Scr. 1/4-20 x .5" Lg.	79	684-0046	Plate Reinforcement Ass'y.—R.H.
32	712-0287	Hex Nut 1/4-20 Thd.*			
33	731-1379	Chute Adapter	80	710-0442	Hex Bolt 5/16-18 x 1.5" Lg.
34	736-0175	Spring Washer 1/4" I.D.	81	705-5225	Chute Reinforcement Ass'y.
35	710-0459	Hex Bolt 3/8-24 x 1.5" Lg. (Gr. 5)	82	721-0325	Plug

† Model 247.885550 only.

†† Model 247.885680 only.

*Common Hardware—May be Purchased Locally.

SEARS CRAFTSMAN 5 AND 8 H.P. SNOW THROWERS MODEL NOS. 247.885550
 247.885680
Repair Parts

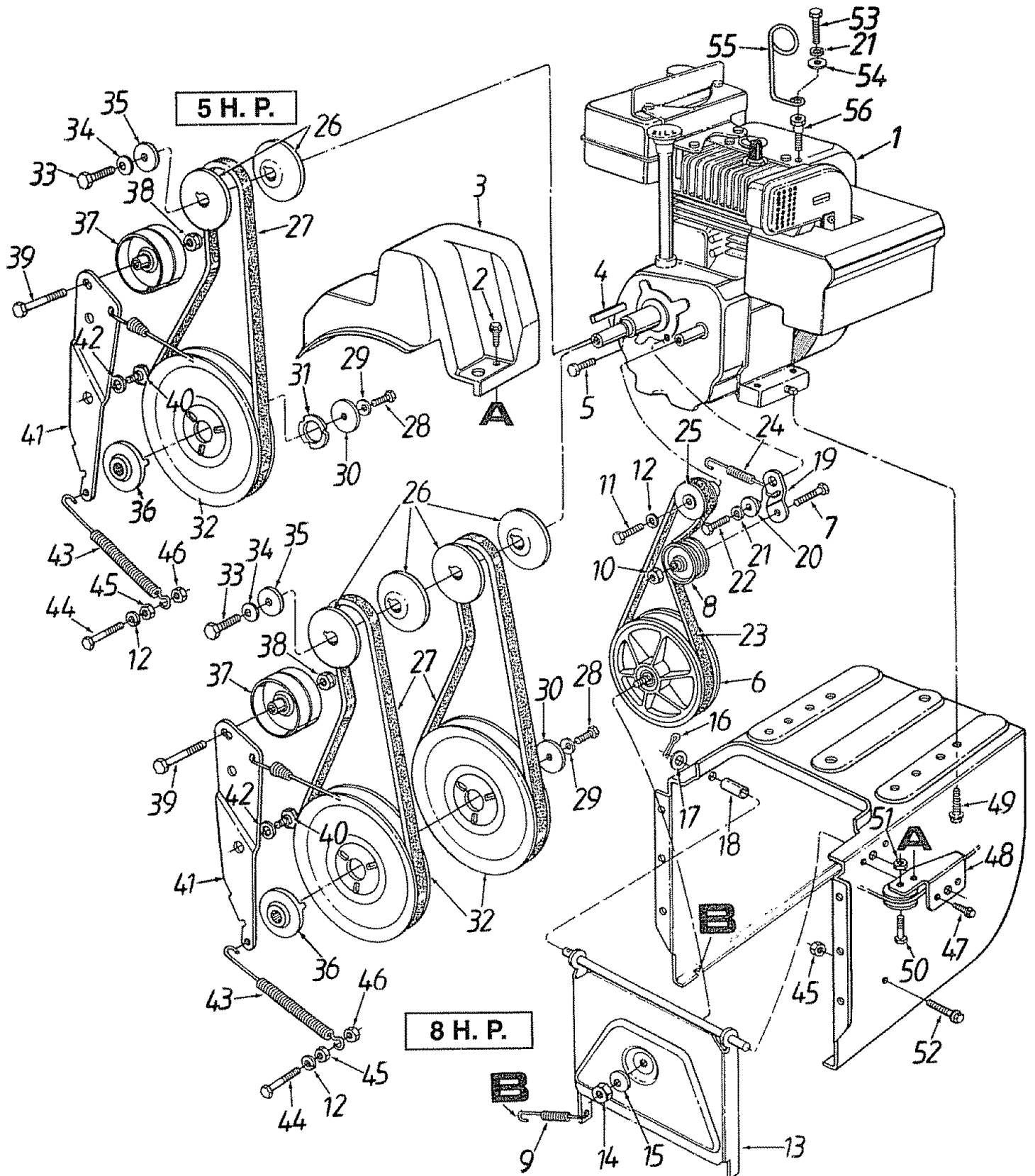

**SEARS CRAFTSMAN 5 AND 8 H.P. SNOW THROWERS MODEL NOS. 247.885550
247.885680**

Repair Parts

KEY NO.	PART NO.	DESCRIPTION	KEY NO.	PART NO.	DESCRIPTION
1	HSSK50-67353N HMSK80-1555245	Engine—Tec. HSSK50-67353N† Engine—Tec. HMSK80-1555245††	27	754-0431 754-0430	"V"-Belt† "V"-Belt††
2	710-0599	Hex Wash. Hd. TT-Tap Scr. 1/4-20 x .5" Lg.	28	710-0627	Hex 5/16-24 x .75" Lg.
3	731-1324	Belt Cover	29	736-0242	Bell-Wash. .345" I.D. x .88" O.D.
4	714-0133 714-0122	Sq.-Key 3/16 x 1.5" Lg.†† Sq.-Key 3/16 x .75" Lg.†	30	736-0505	Fl-Wash. .34" I.D. x 1.5" O.D.
5	710-3166	Hex Patch Bolt 5/16-24 x 1" Lg. (Gr. 5)	31	736-0507	Brg. Retaining Washert†
6	656-0009	Friction Wheel Disc Ass'y.	32	756-0967	Auger Pulley
7	710-0342	Hex Bolt 3/8-16 x 1.25" Lg.	33	710-0696	Hex Bolt 3/8-24 x .88" Lg.
8	756-0313	Fl-Idler 2.12" O.D.	34	736-0331	Bell-Wash. .39" I.D. x 1.13" O.D.
9	732-0264	Ext. Spring 2.5" Lg.	35	736-0247	Fl-Wash. .406" I.D. x 1.25" O.D.
10	712-0181	Hex Top L-Nut 3/8-16 Thd.	36	748-0360	Adapter Pulley
11	710-0230	Hex Bolt 1/4-28 x .5" Lg.	37	756-0178	Fl-Idler 2.75" O.D.
12	736-0329	L-Wash. 1/4" I.D.*	38	712-0116	Hex Ins. L-Nut 3/8-24 Thd.
13	684-0021	Friction Wheel Support Brkt. Ass'y.	39	710-0459	Hex Bolt 3/8-24 x 1.5" Lg. (Gr. 5)
14	712-0711	Hex Jam Nut 3/8-24 Thd.	40	738-0281	Shld. Bolt .625" Dia. x .170" Lg.
15	736-0105	Bell-Wash. .38" I.D. x .88" O.D.	41	784-5632	Auger Idler Brkt.
16	714-0474	Cotter Pin 1/8" x .75" Lg.	42	736-0174	Wave Wash. .66" I.D. x .88"
17	736-0160	Fl-Wash. .531" I.D. x .93" O.D.	43	732-0611	Ext. Spring 3.6" Lg.
18	748-0190	Spacer .508" I.D. x .75" O.D.	44	710-0812	Hex Bolt 1/4-20 x .75" Lg. (Gr. 5)
19	05896	Drive Clutch Idler Bracket	45	712-0287	Hex Nut 1/4-20 Thd.*
20	748-0234	Shld. Spacer .5" Dia. x .27" Lg.	46	712-0291	Hex L-Nut 1/4-20 Thd.
21	736-0119	L-Wash. 5/16" I.D.*†	47	710-1017	Torx Mach. AB-Tap Scr. 1/4 x .62" Lg.
22	710-0117 710-0604	Hex Bolt 5/16-24 x 1" Lg.† Hex Wash. Hd. Tap Scr. 5/16-18 x .62" Lg.††	48	784-5658	Front Support Brkt. Guide
23	754-0343 754-0346	"V"-Belt† "V"-Belt††	49	710-0502	Hex L-Wash. TT-Tap Scr. 3/8-16 x 1.25" Lg.
24	732-0339 732-0710	Extension Spring† Extension Spring††	50	738-0870	Shld. Bolt 5/16" Dia. x .35" Lg.
25	756-0959	2" Dia. Pulley	51	712-0298	Hex Jam Nut 1/4-20 Thd.
26	756-0569	3/8 "V"-Pulley Half	52	710-0788	Hex Wash. Hd. TT-Tap Scr. 1/4-20 x 1" Lg.
			53	710-1087 710-0602	Hex Bolt 5/16-18 x 5/8" Lg.† Hex Wash. Hd. Tap Scr. 5/16-18 x 1" Lg.††
			54	736-0159	Fl-Wash. .349" I.D. x .879" O.D.
			55	732-0705	Cable Control Wire
			56	711-0953	Engine Stud†

† Model 247.885550 only.
†† Model 247.885680 only.

*Common Hardware—May be Purchased Locally.

SEARS CRAFTSMAN 5 AND 8 H.P. SNOW THROWERS MODEL NOS. 247.885550
247.885680
Repair Parts

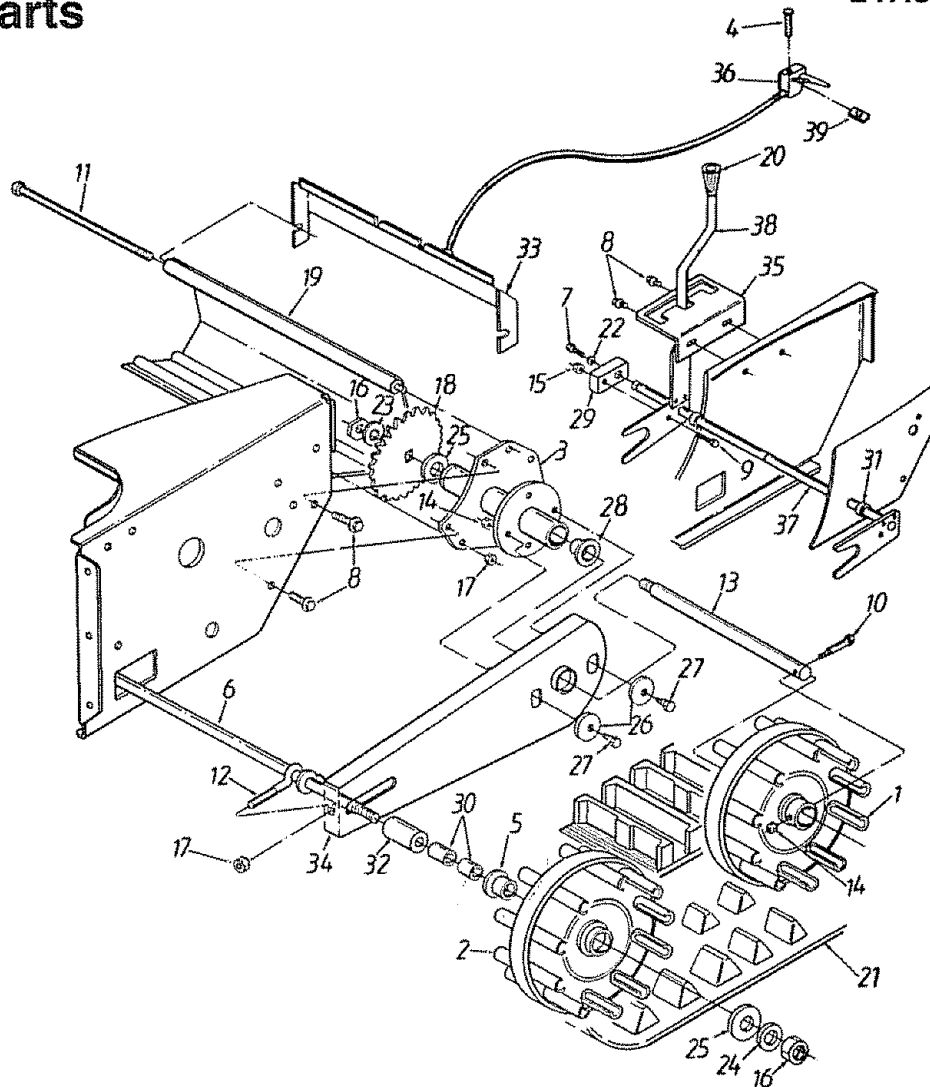

KEY NO.	PART NO.	DESCRIPTION	KEY NO.	PART NO.	DESCRIPTION
1	631-0002	Drive Wheel Ass'y.	19	719-0295	Track Housing
2	631-0004	Idler Wheel Ass'y.	20	720-0223	Grip
3	683-0024	Track Hub Ass'y.	21	731-1292	Snow Track
4	710-1233	Oval C-Sunk Hd. Scr. 10-24 x 1.375" Lg.	22	736-0119	L-Wash. 5/16" I.D.*
5	741-0339	Flange Bearing 3/4" I.D. x 15/16"	23	736-0255	Bell-Wash. .515" I.D. x 1.14" O.D.
6	684-0024	Idler Axle Ass'y.	24	736-0257	Fl-Wash. .628" I.D. x 1.25" O.D.
7	710-0157	Hex Bolt 5/16-24 x .75" Lg.	25	736-0287	Fl-Wash. .793" I.D. x 1.24" O.D.
8	710-0604	Hex Wash. TT-Tap Scr. 5/16-18 x .62" Lg.	26	736-0406	Fl-Wash. 3/8" I.D. x 7/16" O.D.
9	710-0459	Hex Bolt 3/8-24 x 1.5" Lg. (Special)	27	738-0155	Shld. Bolt .437" Dia. x .162
10	710-1227	Bolt 5/16-18 x 1.5" Lg.	28	741-0339	Flange Bearing 3/4" I.D. x 15/16"
11	710-1230	Hex Bolt Ass'y. 5/16-18 x 9.81"	29	748-0353A	Lift Shaft Drive
12	710-1231	Eyebolt 5/16-18 x 3" Lg.	30	750-0499	Spacer .5" I.D. x .78" Lg.
13	711-0941	Drive Axle	31	750-0547	Spacer .628" I.D. x 5" Lg.
14	712-0158	Hex Cent. L-Nut 5/16-18 Thd.	32	750-0909	Spacer .51" I.D. x 1.34" Lg.
15	712-0214	Hex Cent. L-Nut 3/8-24 Thd.	33	784-5609	Steering Cable Brkt.
16	712-0346	Hex Ins. Jam L-Nut 1/2-20 Thd.	34	784-5639	Track Side Plate
17	712-0429	Hex L-Nut 5/16-18 Thd.	35	784-5642	Track Lockout Plate
18	713-0115	24 Tooth Sprocket	36	746-0900	Track Steer Cable w/Trigger
			37	684-0009	Track Pivot Rod Ass'y.
			38	684-0038	Track Lock Handle Ass'y.
			39	712-0127	Flat Weld Nut #10-24 Thd.

TECUMSEH 5 H.P. ENGINE MODEL NO. HSSK50-67353N

Repair Parts

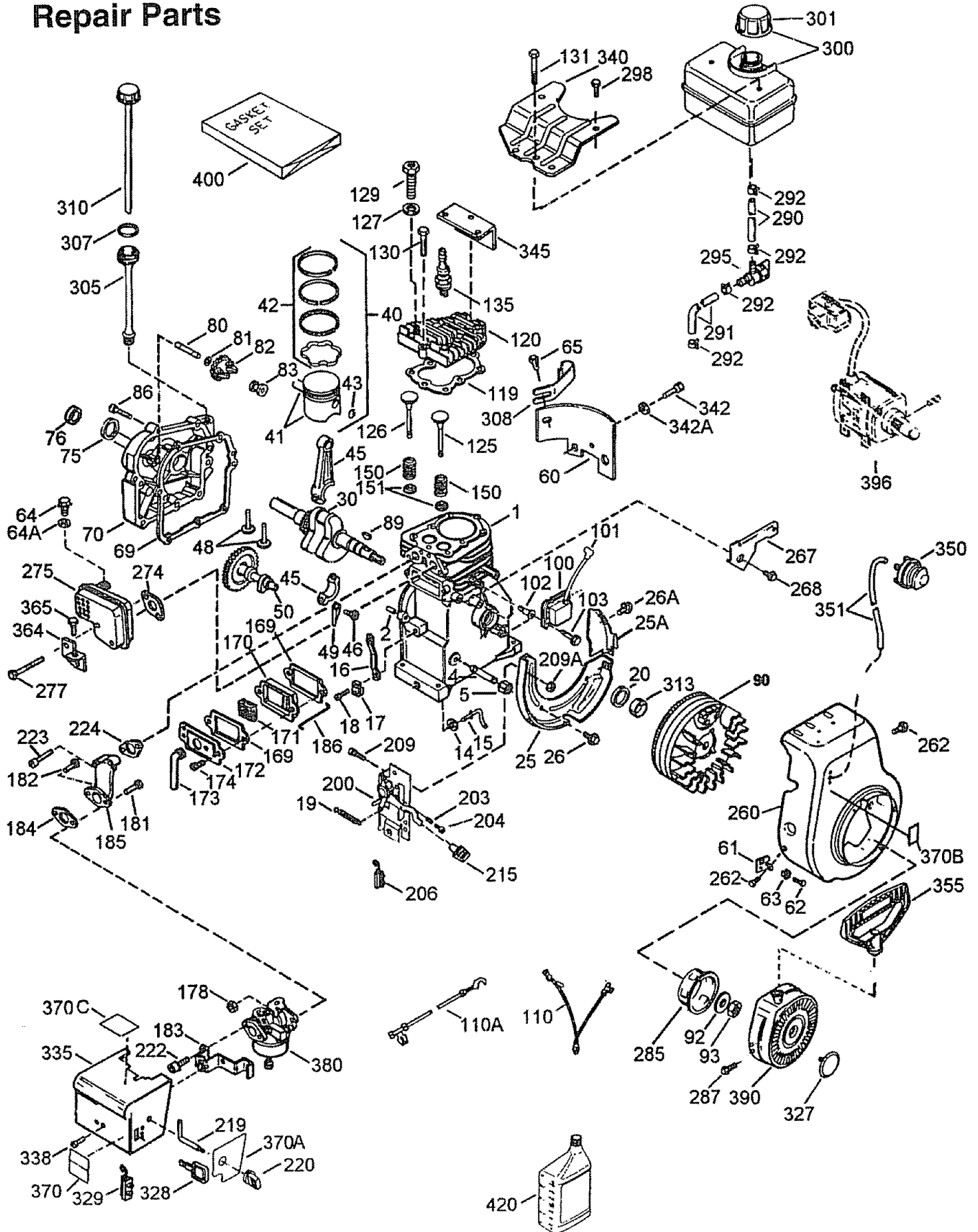

TECUMSEH 5 H.P. ENGINE MODEL NO. HSSK50-67353N

Repair Parts

KEY NO.	PART NO.	DESCRIPTION	QTY.	KEY NO.	PART NO.	DESCRIPTION	QTY.
1	36469	Cylinder (Incl. 2 & 20)	1	110A	35285	Ground Wire	1
2	26727	Dowel Pin	2	119	36443	Cylinder Head Gasket	1
4	34171	Oil Drain Extension	1	120	36441	Cylinder Head (Incl. 131)	1
5	30969	Extension Cap	1	125	29313C	Exhaust Valve (Std.) (Incl. 151)	1
14	28277	Washer	1	125	29315C	Exhaust Valve (1/32" OS)	1
15	31334	Governor Rod	1			(Incl. 151)	1
16	31510	Governor Lever	1	126	32644A	Intake Valve (Std.) (Incl. 151)	1
17	31335	Governor Lever Clamp	1	126	32645A	Intake Valve (1/32" OS)	1
18	650548	Screw, 8-32 x 5/16"	1			(Incl. 151)	1
19	31426	Extension Spring	1	127	650691	Washer	1
20	32600	Oil Seal	1	129	650818	Screw, 5/16-18 x 1-1/2"	1
25	33342	Blower Housing Baffle	1	130	6021A	Screw, 5/16-18 x 1-1/2"	2
25A	35883	Baffle Extension	1	131	650694A	Screw, 5/16-18 x 2"	5
26	650802	Screw, 1/4-20 x 5/8"	2	135	35395	Resistor Spark Plug (RJ19LM)	1
26A	650926	Screw, 8-32 x 21/64"	1	150	31672	Valve Spring	2
30	35975	Crankshaft	1	151	31673	Valve Spring Cap	2
40	36073	Piston, Pin & Ring Set (Std.)	1	169	27234A	Valve Cover Gasket	2
40	36074	Piston, Pin & Ring Set (.010" OS)	1	170	27666	Breather Body	1
40	36075	Piston, Pin & Ring Set (.020" OS)	1	171	31410	Breather Element	1
41	36070	Piston & Pin Ass'y. (Std.)	1	172	34146	Valve Cover	1
		(Incl. 43)	1	173	35350	Breather Tube	1
41	36071	Piston & Pin Ass'y. (.010" OS)	1	174	30200	Screw, 10-24 x 9/16"	2
		(Incl. 43)	1	178	29752	Nut & Lock Washer, 1/4-28	2
41	36072	Piston & Pin Ass'y. (.020" OS)	1	181	650870	Screw, 1/4-28 x 1-11/16"	1
		(Incl. 43)	1	182	6201	Screw, 1/4-28 x 7/8"	1
42	36076	Ring Set (Std.)	1	183	34583	Choke Bracket	1
42	36077	Ring Set (.010" OS)	1	184	26756	Carburetor To Intake Pipe	1
42	36078	Ring Set (.020" OS)	1			Gasket	1
43	20381	Piston Pin Retaining Ring	2	185	33691	Intake Pipe	1
45	32875	Connecting Rod Ass'y. (Incl. 46 & 49)	1	186	32698	Governor Link	1
46	32610A	Connecting Rod Bolt	2	200	33858A	Control Bracket	1
48	27241	Valve Lifter	2	203	31342	Compression Spring	1
49	32654	Oil Dipper	1	204	650549	Screw, 5-40 x 7/16"	1
50	35976	Camshaft (BCR)	1	206	610973	Terminal	1
60	29745	Blower Housing Extension	1	209	650139	Screw, 8-32 x 1/2"	2
61	34126	Grommet Mounting Bracket	1	209A	30322	Lock Nut, 8-32	2
62	650760	Screw, 8-32 x 3/8"	1	215	35440	Control Knob	1
63	28545	Grommet	1	219	34582	Choke Rod	1
64	30063	Screw, Torx T-30, 1/4-20 x 1/2"	1	220	35438	Choke Knob	1
64A	8345	Washer	1	222	28820	Screw, 10-32 x 1/2"	2
65	650128	Screw, 10-24 x 1/2"	1	223	650664	Screw, 1/4-20 x 1-19/32"	2
69	27677A	Cylinder Cover Gasket	1	224	33673A	Intake Pipe Gasket	1
70	34678A	Cylinder Cover (Incl. 75,76 & 80)	1	260	35656A	Blower Housing	1
75	27897	Oil Seal	1	262	29212	Screw, 1/4-28 x 7/16"	2
76	30318	Camshaft Seal	1	267	34212	Hold Down Bracket	1
80	30574A	Governor Shaft	1	268	30200	Screw, 10-24 x 9/16"	1
81	30590A	Washer	1	274	33670A	Exhaust Gasket	1
82	30591	Governor Gear Ass'y. (Incl. 81)	1	275	35771	Muffler (Incl. 274)	1
83	30588A	Governor Spool	1	277	650327	Screw, 1/4-20 x 2-1/2"	2
86	650488	Screw, 1/4-20 x 1-1/4"	7	285	36476	Starter Cup	1
89	610961	Flywheel Key	1	287	650926	Screw, 8-32 x 21/64"	2
90	611199	Flywheel (w/Ring Gear)	1	290	29774	Fuel Line	1
92	650815	Belleville Washer	1	291	30705	Fuel Line	1
93	650863	Flywheel Nut	1	292	26460	Fuel Line Clamp	4
100	34443A	Solid State Ignition	1	295	35857	Fuel Shut-Off Valve	1
101	610118	Spark Plug Cover	1	298	650665	Screw, 1/4-15 x 7/8"	2
102	650872	Solid State Mounting Stud	2	300	35584	Fuel Tank (Incl. 292 & 301)	1
103	650814	Screw, Torx T-15, 10-24 x 1"	2	301	35355	Fuel Cap	1
110	35557	Ground Wire	1	305	35554	Oil Fill Tube	1

TECUMSEH 5 H.P. ENGINE MODEL NO. HSSK50-67353N

Repair Parts

KEY NO.	PART NO.	DESCRIPTION	QTY.	KEY NO.	PART NO.	DESCRIPTION	QTY.
307	35499	"O" Ring	1	364	33333	Carburetor Cover Bracket	1
308	35539	Fill Tube Clip	1	365	650735	Screw, 10-24 x 3/8"	1
310	35556	Dipstick	1	370	36261	Lubrication Decal	1
313	34080	Spacer	1	370A	35282	Control Decal	1
327	35392	Starter Plug	1	370B	36501	Primer Decal	1
328	35062	Switch Key	2	370C	34414	Warning Decal	1
329	610973	Terminal	1	380	632107A	Carburetor (Incl. 184)	1
335	35072	Carburetor Cover	1	390	590646	Rewind Starter	1
338	650257	Screw, 8-32 x 5/16"	2	396	33290D	Electric Starter Motor (110 Volt) (Optional)	0
340	36247	Fuel Tank Bracket	1	400	36444	Gasket Set	1
342	30063	Screw, Torx T-30, 1/4-20 x 1/2"	1	420	730226	SAE 5W30 4-Cycle Engine Oil (Quart)	1
342A	650675	Washer	2			RPM High 3450 to 3750	
345	33344	Heat Baffle	1			RPM Low 2000 to 2300	
350	570682	Primer Ass'y.	1				
351	32180C	Primer Line	1				
355	590574	Starter Handle	1				

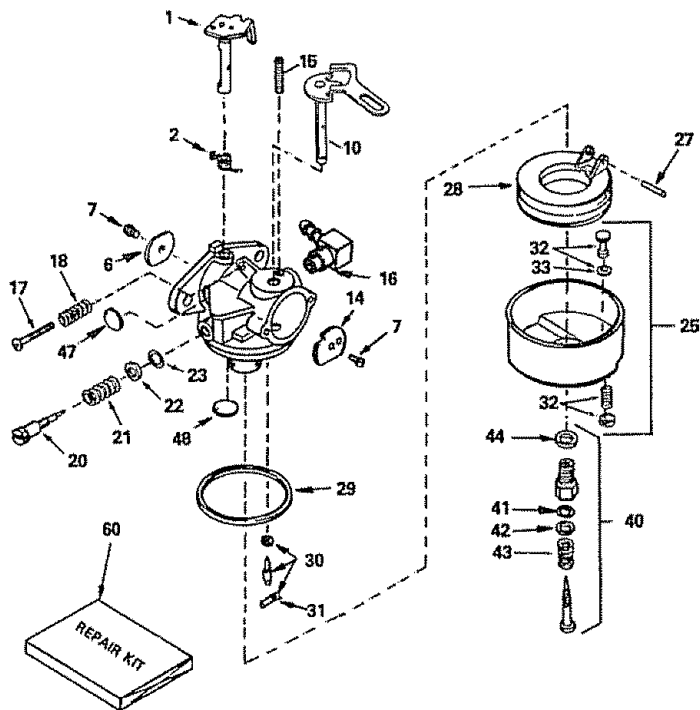

KEY NO.	PART NO.	DESCRIPTION	QTY.
0	632107A	Carburetor (Incl. 184 of Engine Parts List)	1
1	631615	Throttle Shaft & Lever Assembly	1
2	631767	Throttle Return Spring	1
6	631036	Throttle Shutter	1
7	650506	Shutter Screw	2
10	632108	Choke Shaft & Lever Assembly	1
14	631815	Choke Shutter	1
15	630735	Choke Positioning Spring	1
16	631807	Fuel Fitting	1
17	650417	Throttle Crack Screw/Idle Speed Screw	1
18	630766	Tension Spring	1
20	631838	Idle Mixture Screw	1
21	630766	Tension Spring	1
22	630739	Idle Mixture Screw Washer	1
23	630740	Idle Mixture Screw "O" Ring	1
25	631951	Float Bowl Ass'y. (Incl. 32 & 33)	1
27	631024	Float Shaft	1
28	632019	Float	1
29	631028	Float Bowl "O" Ring	1
30	631021	Inlet Needle, Seat & Clip (Incl. 31)	1
31	631022	Spring Clip	1
32	27136A	Bowl Drain Assembly	1
33	27554	Drain Plunger Gasket	1
40	31839	Main Adj. Screw Ass'y. (Incl. 41 thru 44)	1
41	630740	High Speed Mixture Screw "O" Ring	1
42	630739	High Speed Mixture Screw Washer	1
43	630738	High Speed Mixture Screw Tension Spring	1
44	27110	Bowl Nut Washer	1
47	630748	Welch Plug, Idle Mixture Well	1
48	631027	Welch Plug, Atmospheric Vent	1
60	31840	Repair Kit	1

TECUMSEH 5 H.P. ENGINE MODEL NO. HSSK50-67353N
Repair Parts

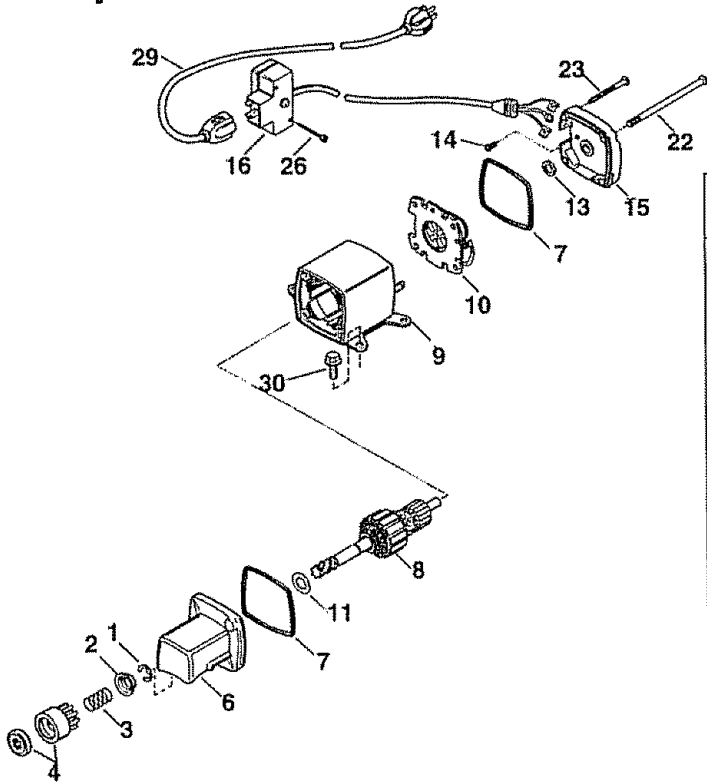

KEY NO.	PART NO.	DESCRIPTION	QTY.
0	33290D	Electric Starter (110 Volt)	1
1	31749	Retainer Ring	1
2	33522	Spring Retainer	1
3	33769	Anti-drift Spring	1
4	33524	Nut & Gear	1
5	35911	Thrust Washer	1
6	35461	Drive End Cap Ass'y. (Incl. 7)	1
7	35450	"O" Ring	2
8	35912	Armature	1
9	35459A	Housing Ass'y.	1
10A	35452A	Brush & Spring Card Ass'y.	1
13	590500	Thrust Washer	1
14	33441	Ground Screw	1
15	35453	Commutator End Cap Ass'y. (Incl. 7)	1
16A	35454	Switch Box Ass'y. (Incl. 21)	1
24	35462	Case Bolt	2
25	35456	Grounding Screw	1
27A	650819	Screw, 6-32 x 2-1/2"	2
30	32450B	Extension Cord (10'6")	1
31	650759	Screw, Torx T-30, 1/4-20 x 23/32"	3

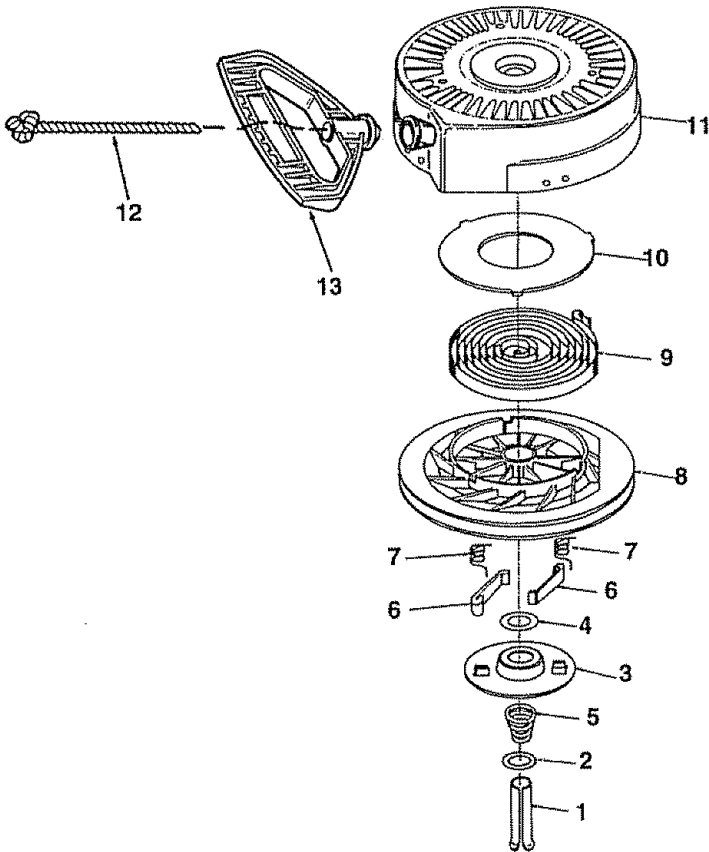

KEY NO.	PART NO.	DESCRIPTION	QTY.
0	590646	Recoil Starter	1
1	590599A	Spring Pin (Incl. 4)	1
2	590600	Washer	1
3	590615	Retainer	1
4	590601	Washer	1
5	590598	Brake Spring	1
6	590616	Starter Dog	2
7	590617	Dog Spring	2
8	590645A	Pulley Ass'y. (Incl. 9 & 10)	1
9	590619	Rewind Spring	1
10	590620	Spring Cover	1
11	590647	Starter Housing Ass'y.	1
12	590535	Starter Rope (Length 98" x 9/64" dia.)	1
13	590574	Mitten Grip Handle (Not included with starter)	1

TECUMSEH 8 H.P. ENGINE MODEL NO. HMSK80-155524S

Repair Parts

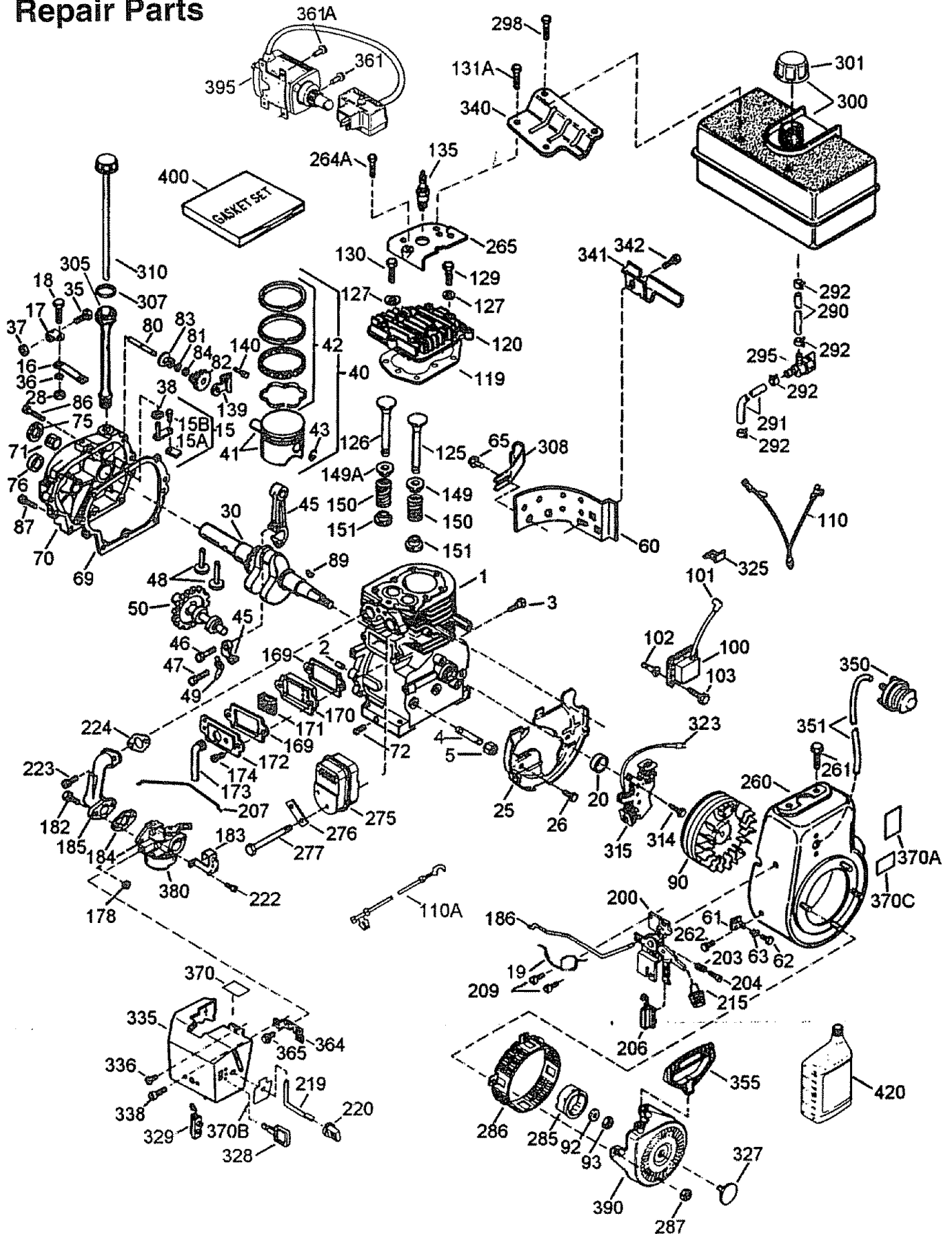

TECUMSEH 8 H.P. ENGINE MODEL NO. HMSK80-155524S

Repair Parts

KEY NO.	PART NO.	DESCRIPTION	QTY.	KEY NO.	PART NO.	DESCRIPTION	QTY.
1	35385	Cylinder (Incl. 2, 20 & 72)	1	92	650880	Lock Washer	1
2	27652	Dowel Pin	2	93	650881	Flywheel Nut	1
3	650820	Screw, 1/4-20 x 1/2"	2	100	35135	Solid State Ignition	1
4	34171	Oil Drain Extension	1	101	610118	Spark Plug Cover	1
5	30969	Extension Cap	1	102	650872	Solid State Mounting Stud	2
15	30699C	Governor Rod (Incl. 15A & 15B)	1	103	650814	Screw, Torx T-15, 10-24 x 1"	2
15A	30700	Governor Yoke	1	110	35253	Ground Wire	1
15B	650494	Screw, 6-40 x 5/16"	1	110A	35305	Ground Wire	1
16	33454	Governor Lever	1	119	36448	Cylinder Head Gasket	1
17	29916	Governor Lever Clamp	1	120	36449	Cylinder Head	1
18	650548	Screw, 8-32 x 5/16"	1	125	27878A	Exhaust Valve (Std.) (Incl. 151)	1
19	34663	Speed Control Spring	1	125	27880A	Exhaust Valve (1/32" OS)	1
20	35319	Oil Seal	1			(Incl. 151)	1
25	36460	Blower Housing Baffle	1	126	34035	Intake Valve (Std.) (Incl. 151)	1
26	650561	Screw, 1/4-20 x 5/8"	2	126	34036	Intake Valve (1/32" OS)	1
28	30322	Lock Nut, 8-32	1			(Incl. 151)	1
30	35980A	Crankshaft	1	127	650691	Washer	2
35	29826	Screw, 10-32 x 3/4"	1	129	650727	Screw, 5/16-18 x 1-3/4"	2
36	29918	Lock Washer	1	130	6021A	Screw, 5/16-18 x 1-1/2"	7
37	29216	Lock Nut, 10-32	1	131A	650713	Screw, 5/16-18 x 5/8"	2
38	29642	Retaining Ring	1	135	35395	Resistor Spark Plug (RJ17LM)	1
40	34552	Piston, Pin & Ring Set (Std.)	1	139	33369	Governor Gear Bracket	1
40	34553	Piston, Pin & Ring Set (.010" OS)	1	140	650836	Screw, 10-24 x 1/2"	2
40	34554	Piston, Pin & Ring Set (.020" OS)	1	149	27882	Valve Spring Cap	1
41	34329A	Piston & Pin Ass'y. (Std.)	1	149A	35862	Valve Spring Cap	1
		(Incl. 43)	1	150	27881	Valve Spring	2
41	34330A	Piston & Pin Ass'y. (.010" OS)	1	151	32581	Valve Spring Keeper	2
		(Incl. 43)	1	169	27896A	Valve Cover Gasket	2
41	34331A	Piston & Pin Ass'y. (.020" OS)	1	170	28423	Breather Body	1
		(Incl. 43)	1	171	28424	Breather Element	1
42	34332	Ring Set (Std.)	1	172	28425	Valve Cover	1
42	34333	Ring Set (.010" OS)	1	173	35350	Breather Tube	1
42	34334	Ring Set (.020" OS)	1	174	650128	Screw, 10-24 x 1/2"	2
43	27888	Piston Pin Retaining Ring	2	178	29752	Nut & Lock Washer, 1/4-28	2
45	35373A	Connecting Rod Ass'y. (Incl. 46, 47, 49)	1	182	30088A	Screw, 1/4-28 x 1"	2
			1	183	34587	Choke Bracket	1
46	650908	Connecting Rod Bolt	1	184	33263	Carburetor To Intake Pipe	1
47	650882	Connecting Rod Bolt	1			Gasket	1
48	34034	Valve Lifter	2	185	33877	Intake Pipe	1
49	35374	Oil Dipper	1	186	34667	Governor Link	1
50	35981	Camshaft (MCR)	1	200	34677	Control Bracket (Incl. 19, 203, 204 & 206)	1
60	33273A	Blower Housing Extension	1				1
61	34126	Grommet Mounting Bracket	1	203	31342	Compression Spring	1
62	650760	Screw, 8-32 x 3/8"	1	204	650549	Screw, 5-40 x 7/16"	1
63	28545	Grommet	1	206	610973	Terminal	1
65	650128	Screw, 10-24 x 1/2"	1	207	33878	Throttle Link	1
69	35262	Cylinder Cover Gasket	1	209	650821	Screw, 10-32 x 1/2"	2
70	35445A	Cylinder Cover (Incl. 71, 75 & 80)	1	215	35440	Control Knob	1
71	35377	Crankshaft Bushing	1	219	34586	Choke Rod	1
75	35319	Oil Seal	1	220	35438	Choke Knob	1
76	28926	Camshaft Seal	1	222	28820	Screw, 10-32 x 1/2"	2
80	31845	Governor Shaft	1	223	650378	Screw, Torx T-30, 5/16-18 x 1-1/8"	2
81	30590A	Washer	1				1
82	35378	Governor Gear Ass'y. (Incl. 81)	1	224	27915A	Intake Pipe Gasket	1
83	30588A	Governor Spool	1	260	35447A	Blower Housing	1
84	29193	Retaining Ring	1	261	650788	Screw, 5/16-18 x 3/4"	2
86	650833	Screw, 1/4-20 x 1-3/16"	7	262	29747B	Screw, Torx T-40, 5/16-24 x 21/32"	1
87	650832	Screw, 1/4-20 x 1-11/16"	1				1
89	32589	Flywheel Key	1	264A	650802	Screw, 1/4-20 x 5/8"	1
90	611093	Flywheel (w/Ring Gear)	1	265	33272B	Cylinder Head Cover	1

TECUMSEH 8 H.P. ENGINE MODEL NO. HMSK80-155524S

Repair Parts

KEY NO.	PART NO.	DESCRIPTION	QTY.	KEY NO.	PART NO.	DESCRIPTION	QTY.
275	35056	Muffler	1	335	35057A	Carburetor Cover	1
276	31588	Locking Plate	1	336	650765	Screw, 10-32 x 1/2"	1
277	792093	Screw, 5/16-18 x 4-3/16"	2	338	28942	Screw, 10-32 x 3/8"	2
285	35985A	Starter Cup	1	340	34155	Fuel Tank Bracket	1
286	35446	Starter Screen	1	341	34154	Fuel Tank Bracket	1
287	29752	Nut & Lock Washer, 1/4-28	4	342	650561	Screw, 1/4-20 x 5/8"	1
290	29774	Fuel Line	1	350	570682	Primer Ass'y.	1
291	30705	Fuel Line	1	351	32180C	Primer Line	1
292	26460	Fuel Line Clamp	4	355	590574	Starter Handle	1
295	35857	Fuel Shut-Off Valve	1	361	30063	Screw, Torx T-30, 1/4-20 x 1/2"	2
298	650665	Screw, 1/4-15 x 7/8"	2	361A	650819	Screw, 6-32 x 2-1/2"	2
300	34156A	Fuel Tank (Incl. 292 & 301)	1	364	33377	Carburetor Cover Bracket	1
301	35355	Fuel Cap	1	365	650767	Screw, 8-32 x 27/64"	2
305	35554	Oil Fill Tube	1	370	35077	Control Decal	1
307	35499	"O" Ring	1	370A	36501	Primer Decal	1
308	35540	Fill Tube Clip	1	370B	36261	Instruction Decal	1
310	36205	Dipstick	1	370C	34414	Warning Decal	1
314	650873	Screw, 1/4-20 x 3/4"	1	380	632334A	Carburetor (Incl. 184)	1
315	611111	Alternator Coil (18 Watt) (Incl. 323)	1	390	590672	Rewind Starter	1
323	611118	Terminal	1	395	33329D	Electric Starter Motor (120 Volt)	1
325	29443	Wire Clip	1	400	36450	Gasket Set	1
327	35392	Starter Plug	1	420	730226	SAE 5W30 4-Cycle Engine Oil (Quart)	1
328	35062	Ignition Key	2			RPM Low 1700	
329	610973	Terminal	1			RPM High 3450 to 3750	

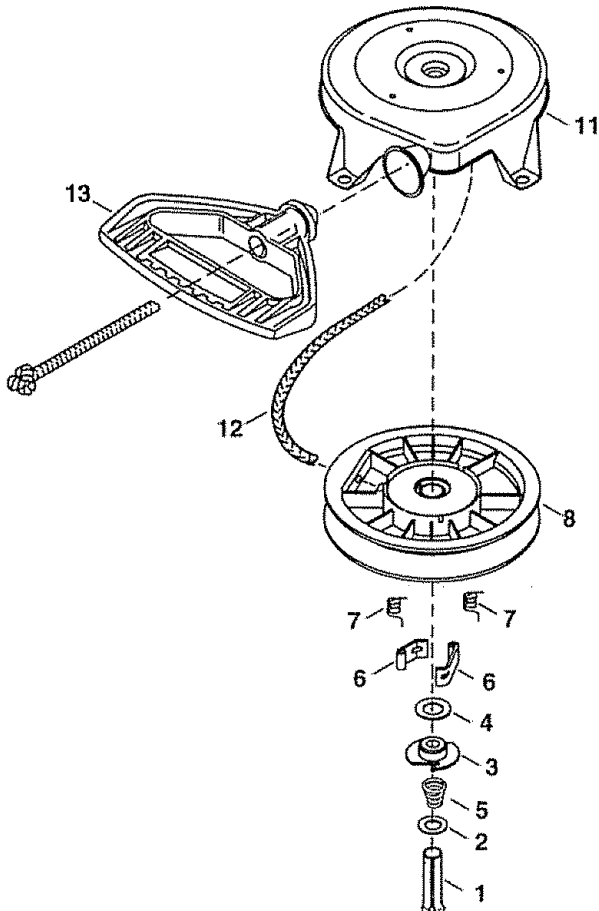

KEY NO.	PART NO.	DESCRIPTION	QTY.
0	590672	Rewind Starter	1
1	590599A	Spring Pin (Incl. 4)	1
2	590600	Washer	1
3	590679	Retainer	1
4	590601	Washer	1
5	590678	Brake Spring	1
6	590680	Starter Dog	2
7	590412	Dog Spring	2
8	590682	Pulley & Rewind Spring Ass'y.	1
11	590684	Starter Housing Ass'y.	1
12	590456	Starter Rope (Length 114" x 1 1/64" dia.)	1
13	590574	Mitten Grip Handle (Not included with starter)	1

TECUMSEH 8 H.P. ENGINE MODEL NO. HMSK80-155524S
Repair Parts

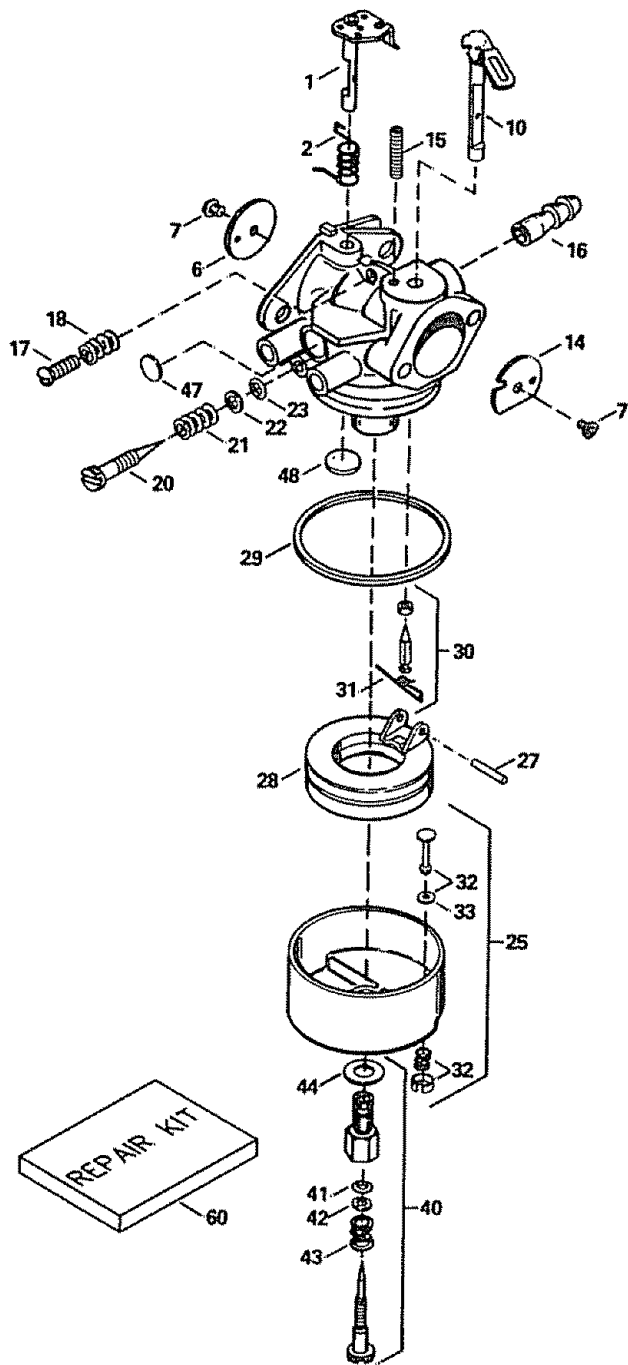

KEY NO.	PART NO.	DESCRIPTION	QTY.
0	632334A	Carburetor (Incl. 184 of Engine Parts List)	1
1	631776A	Throttle Shaft & Lever Assembly	1
2	631970	Throttle Return Spring	1
6	631778	Throttle Shutter	1
7	650506	Shutter Screw	2
10	632112	Choke Shaft & Lever Assembly	1
14	632174	Choke Shutter	1
15	630735	Choke Positioning Spring	1
16	632164	Fuel Fitting	1
17	650417	Throttle Crack Screw/Idle Speed Screw	1
18	630766	Tension Spring	1
20	632281	Idle Mixture Screw	1
21	630766	Tension Spring	1
22	630739	Idle Mixture Screw Washer	1
23	630740	Idle Mixture Screw "O" Ring	1
25	631951	Float Bowl Ass'y. (Incl. 32 & 33)	1
27	631024	Float Shaft	1
28	632019	Float	1
29	631028	Float Bowl "O" Ring	1
30	631021	Inlet Needle, Seat & Clip (Incl. 31)	1
31	631022	Spring Clip	1
32	27136A	Bowl Drain Assembly	1
33	27554	Drain Plunger Gasket	1
40	632239	Main Adj. Screw Ass'y. (Incl. 41 thru 44)	1
41	630740	High Speed Mixture Screw "O" Ring	1
42	630739	High Speed Mixture Screw Washer	1
43	630738	High Speed Mixture Screw Tension Spring	1
44	27110	Bowl Nut Washer	1
47	630748	Welch Plug, Idle Mixture Well	1
48	631027	Welch Plug, Atmospheric Vent	1
60	632347	Repair Kit	1

TECUMSEH 8 H.P. ENGINE MODEL NO. HMSK80-155524S
Repair Parts

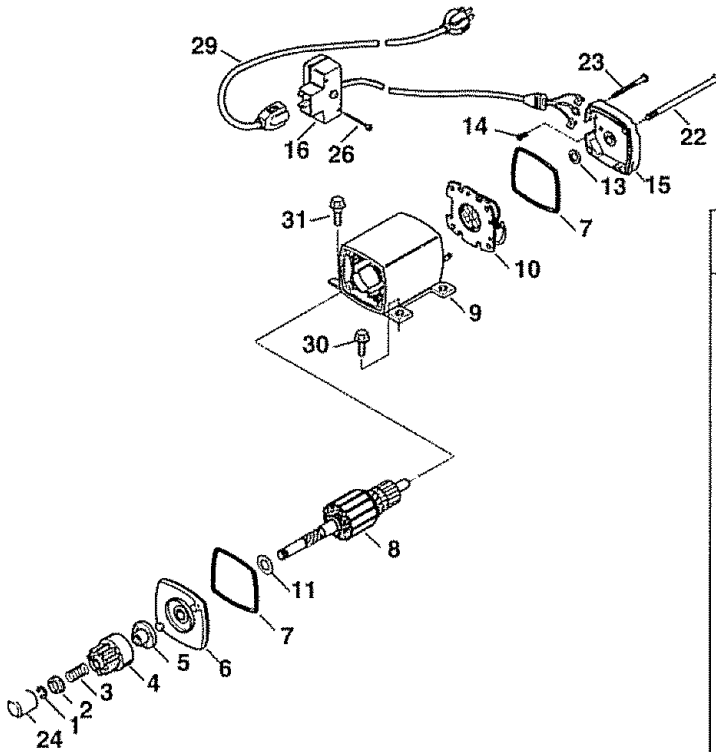

KEY NO.	PART NO.	DESCRIPTION	QTY.
0	33329D	Electric Starter (110 Volt)	1
1	33842	Retainer Ring	1
2	33430	Spring Retainer	1
3	33431	Anti-drift Spring	1
4	33432	Gear	1
5	35893	Retainer & Nut (Incl. 1)	1
6	35449	Drive End Cap Ass'y. (Incl. 7)	1
7	35450	"O" Ring	2
8	35915	Armature	1
9	35451A	Housing Ass'y.	1
10	35452A	Brush Card Ass'y.	1
11	35911	Thrust Washer	1
13	590500	Thrust Washer	1
14	33441	Ground Screw	1
15	35453	Commutator End Cap Ass'y. (Incl. 7)	1
16	35454	Switch Box Ass'y. (Incl. 26)	1
22	35455	Case Bolt	2
23	35456	Grounding Screw	1
24	33451	Dust Cover	1
26	650819	Screw, 6-32 x 2-1/2"	2
29	32450B	Extension Cord (10'6")	1
30	30063	Screw, T-30 Torx, 1/4-20 x 1/2"	2
31	650820	Screw, 1/4-20 x 1/2"	2

SEARS

**OWNER'S
MANUAL**

**MODEL NOS.
247.885550
247.885680**

**HOW TO ORDER
REPAIR PARTS**

CRAFTSMAN®

Each snow thrower has its own model number. Each engine has its own model number.

The model number for your snow thrower will be found on a label attached to the frame.

The model number for the engine will be found on the blower housing of the engine.

All parts listed herein may be ordered through Sears, Roebuck and Co. Service Centers and most Retail Stores.

WHEN ORDERING REPAIR PARTS, ALWAYS GIVE THE FOLLOWING INFORMATION:

***PRODUCT—5 H.P. Snow Thrower
8 H.P. Snow Thrower**

***MODEL NUMBER - 247.885550
247.885680**

***ENGINE MODEL NO. - HSSK50-67353N
HMSK80-155524S**

***PART NUMBER**

***PART DESCRIPTION**

Your Sears merchandise has added value when you consider that Sears has service units nationwide staffed with Sears trained technicians...professional technicians specifically trained on Sears products, having the parts, tools and the equipment to insure that we meet our pledge to you...“we service what we sell.”