

# INSTALLATION INSTRUCTIONS

## 30" (76.2 CM) FREESTANDING GAS RANGE

with standard clean oven

---

Table of Contents.....2

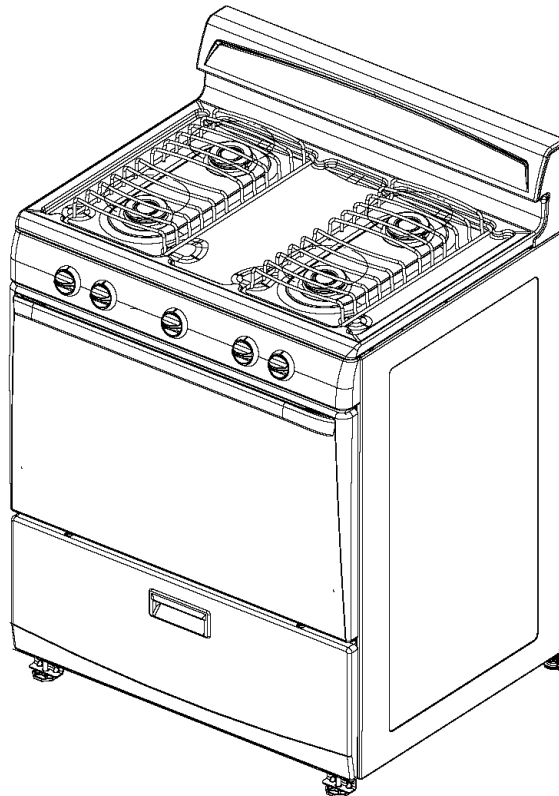

To the installer: Please leave this instruction book with the unit.

To the consumer: Please read and keep this book for future reference.

---

# TABLE OF CONTENTS

<b>RANGE SAFETY</b> .....	2
<b>INSTALLATION REQUIREMENTS</b> .....	4
Tools and Parts .....	4
Location Requirements.....	4
Electrical Requirements .....	6
Gas Supply Requirements .....	6
<b>INSTALLATION INSTRUCTIONS</b> .....	8
Unpack Range .....	8
Install Anti-Tip Bracket .....	8
Verify Anti-Tip Bracket Location .....	9
Level Range .....	9
Make Gas Connection.....	9
Check Operation .....	10
Complete Installation .....	11
<b>GAS CONVERSIONS</b> .....	12
LP Gas Conversion .....	12
Complete Conversion .....	13
Natural Gas Conversion.....	14
Complete Conversion .....	15

---

## RANGE SAFETY

### Your safety and the safety of others are very important.

We have provided many important safety messages in this manual and on your appliance. Always read and obey all safety messages.



This is the safety alert symbol.

This symbol alerts you to potential hazards that can kill or hurt you and others.

All safety messages will follow the safety alert symbol and either the word "DANGER" or "WARNING."

These words mean:

**⚠ DANGER**

You can be killed or seriously injured if you don't immediately follow instructions.

**⚠ WARNING**

You can be killed or seriously injured if you don't follow instructions.

All safety messages will tell you what the potential hazard is, tell you how to reduce the chance of injury, and tell you what can happen if the instructions are not followed.

**WARNING:** If the information in this manual is not followed exactly, a fire or explosion may result causing property damage, personal injury or death.

- Do not store or use gasoline or other flammable vapors and liquids in the vicinity of this or any other appliance.
- **WHAT TO DO IF YOU SMELL GAS:**
  - Do not try to light any appliance.
  - Do not touch any electrical switch.
  - Do not use any phone in your building.
  - Immediately call your gas supplier from a neighbor's phone. Follow the gas supplier's instructions.
  - If you cannot reach your gas supplier, call the fire department.
- Installation and service must be performed by a qualified installer, service agency, or the gas supplier.

In the State of Massachusetts, the following installation instructions apply:

- Installations and repairs must be performed by a qualified or licensed contractor, plumber, or gasfitter qualified or licensed by the State of Massachusetts.
- If using a ball valve, it shall be a T-handle type.
- A flexible gas connector, when used, must not exceed 3 feet.

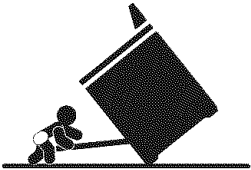

## **⚠ WARNING**

### **Tip Over Hazard**

- A child or adult can tip the range and be killed.
- Connect anti-tip bracket to rear range foot.
- Reconnect the anti-tip bracket, if the range is moved.
- Failure to follow these instructions can result in death or serious burns to children and adults.

# INSTALLATION REQUIREMENTS

## Tools and Parts

Gather the required tools and parts before starting installation. Read and follow the instructions provided with any tools listed here.

### Tools needed

- Level
- 3/8" drive ratchet
- Tape measure
- Flat-blade screwdriver
- Phillips screwdriver
- Hand or electric drill
- Slip-joint pliers
- 7 mm combination wrench
- Pipe wrench
- 1/8" (3.2 mm) drill bit (for wood floors)
- 3/16" (4.8 mm) carbide-tipped masonry drill bit (for concrete/ceramic floors)
- Pipe joint compound resistant to LP gas
- Non-corrosive leak-detection solution

### Parts supplied

Check that all parts are included.

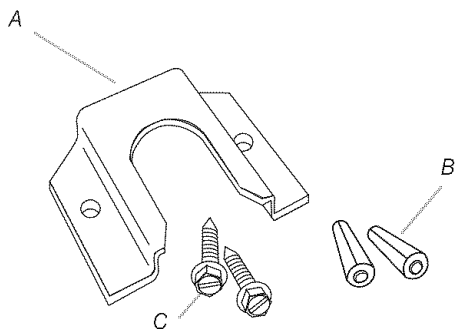

A. Anti-tip bracket  
B. Plastic anchors (2)  
C. #10 x 1 1/2" screws (2)

- Anti-tip brackets must be securely mounted to subfloor. Thickness of flooring may require longer screws to anchor bracket to subfloor. Longer screws are available from your local hardware store.

### Parts needed

Check local codes and consult gas supplier. Check existing gas supply and electrical supply. See "Electrical Requirements" and "Gas Supply Requirements" sections.

## Location Requirements

**IMPORTANT:** Observe all governing codes and ordinances. Do not obstruct flow of combustion and ventilation air.

- It is the installer's responsibility to comply with installation clearances specified on the model/serial rating plate. The model/serial rating plate is located on the oven frame behind the left side of the broiler door.

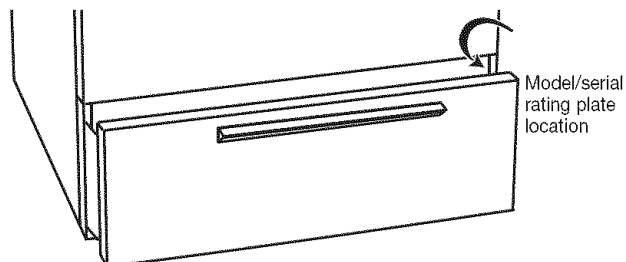

- The range should be located for convenient use in the kitchen.
- Recessed installations must provide complete enclosure of the sides and rear of the range.
- To eliminate the risk of burns or fire by reaching over heated surface units, cabinet storage space located above the surface units should be avoided. If cabinet storage is to be provided, the risk can be reduced by installing a range hood that projects horizontally a minimum of 5" (12.7 cm) beyond the bottom of the cabinets.
- All openings in the wall or floor where range is to be installed must be sealed.
- Do not seal the range to the side cabinets.
- Cabinet opening dimensions that are shown must be used. Given dimensions are minimum clearances.
- The floor anti-tip bracket must be installed. To install the anti-tip bracket shipped with the range, see "Install Anti-Tip Bracket" section.
- Grounded electrical supply is required. See "Electrical Requirements" section. Proper gas supply connection must be available. See "Gas Supply Requirements" section.
- Contact a qualified floor covering installer to check that the floor covering can withstand at least 200°F (93°C).
- Use an insulated pad or 1/4" (0.64 cm) plywood under range if installing range over carpeting.

**IMPORTANT:** Some cabinet and building materials are not designed to withstand the heat produced by the oven for baking and self-cleaning. Check with your builder or cabinet supplier to make sure that the materials used will not discolor, delaminate or sustain other damage.

### Mobile Home - Additional Installation Requirements

The installation of this range must conform to the Manufactured Home Construction and Safety Standard, Title 24 CFR, Part 3280 (formerly the Federal Standard for Mobile Home Construction and Safety, Title 24, HUD Part 280). When such standard is not applicable, use the Standard for Manufactured Home Installations, ANSI A225.1/NFPA 501A or with local codes.

### Mobile home installations require:

- When this range is installed in a mobile home, it must be secured to the floor during transit. Any method of securing the range is adequate as long as it conforms to the standards listed above.

## Product Dimensions

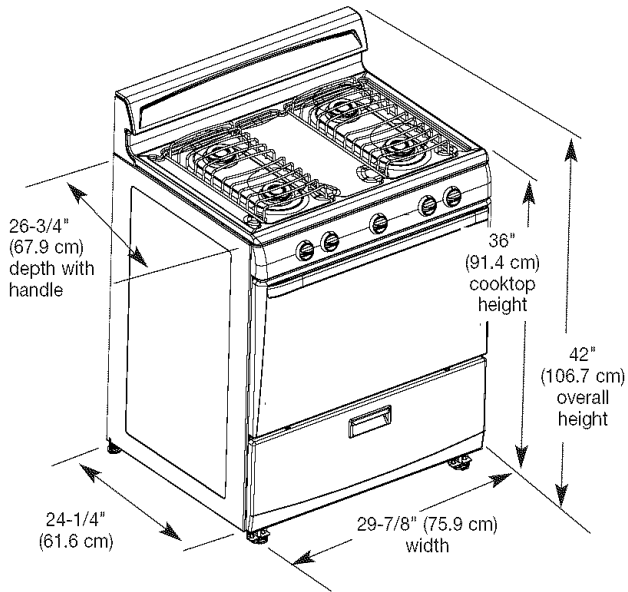

## Installation Clearances

Cabinet opening dimensions shown are for 25" (64 cm) counter-top depth, 24" (61 cm) base cabinet depth and 36" (91.4 cm) countertop height.

If the cabinet depth is greater than 24" (61 cm), the oven frame must extend beyond cabinet fronts by 1/2" (13 mm) minimum.

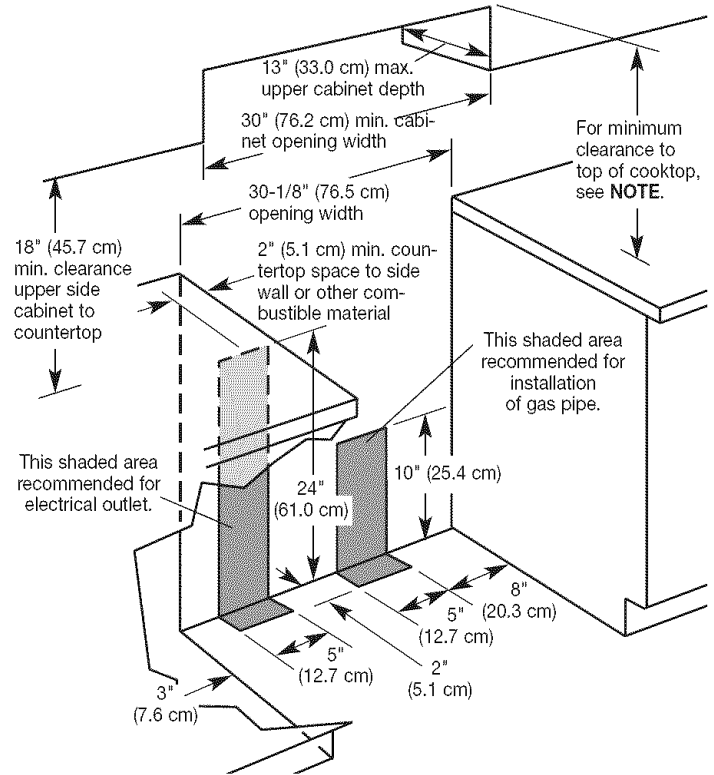

**NOTE:** 24" (61 cm) minimum when bottom of wood or metal cabinet is protected by not less than 1/4" (0.64 cm) flame retardant millboard covered with not less than No. 28 MSG sheet steel, 0.015" (0.4 mm) stainless steel, 0.024" (0.6 mm) aluminum or 0.020" (0.5 mm) copper.

30" (76.2 cm) minimum clearance between the top of the cooking platform and the bottom of an unprotected wood or metal cabinet.

If installing a range hood or microwave hood combination above the range, follow the range hood or microwave hood combination installation instructions for dimensional clearances above the cooktop surface.

## Electrical Requirements

### **⚠ WARNING**



#### Electrical Shock Hazard

- Plug into a grounded 3 prong outlet.
- Do not remove ground prong.
- Do not use an adapter.
- Do not use an extension cord.
- Failure to follow these instructions can result in death, fire, or electrical shock.

**IMPORTANT:** The range must be electrically grounded in accordance with local codes and ordinances, or in the absence of local codes, with the National Electrical Code, ANSI/NFPA 70, latest edition.

If codes permit and a separate ground wire is used, it is recommended that a qualified electrical installer determine that the ground path is adequate.

A copy of the above code standards can be obtained from:

National Fire Protection Association  
One Batterymarch Park, Quincy, MA 02269

CSA International  
8501 East Pleasant Valley Road  
Cleveland, Ohio 44131-5575

- A 120-volt, 60-Hz, AC-only, 15-amp, fused electrical circuit is required. A time-delay fuse or circuit breaker is also recommended. It is recommended that a separate circuit serving only this range be provided.
- This range is equipped with a power supply cord having a 3 prong ground plug. To minimize possible shock hazard, the cord must be plugged into a mating 3 prong, grounded outlet.
- Electronic ignition systems operate within wide voltage limits, but proper grounding and polarity are necessary. Check that the outlet provides 120-volt power and is correctly grounded.  
This range is equipped with an electronic ignition system that will not operate if plugged into an outlet that is not properly polarized.
- The wiring diagram is located on the back of the range.

**NOTE:** The metal chassis of the range must be grounded in order for the control panel to work. If the metal chassis of the range is not grounded, no keypads will operate. Check with a qualified electrician if you are in doubt as to whether the metal chassis of the range is grounded.

## Gas Supply Requirements

### **⚠ WARNING**



#### Explosion Hazard

- Use a new CSA International approved gas supply line.
- Install a shut-off valve.
- Securely tighten all gas connections.
- If connected to LP, have a qualified person make sure gas pressure does not exceed 14" (36 cm) water column.
- Examples of a qualified person include:  
licensed heating personnel,  
authorized gas company personnel, and  
authorized service personnel.
- Failure to do so can result in death, explosion, or fire.

Observe all governing codes and ordinances.

**IMPORTANT:** This installation must conform with all local codes and ordinances. In the absence of local codes, installation must conform with American National Standard, National Fuel Gas Code ANSI Z223.1 - latest edition.

### Type of Gas

#### Natural Gas:

This range is design-certified by the CSA International for use with natural gas or, after proper conversion, for use with LP gas.

- This range is factory set for use with natural gas. See "Gas Conversions" section. The model/serial rating plate located on the frame behind the broiler door has information on the types of gas that can be used. If the types of gas listed do not include the type of gas available, check with the local gas supplier.

#### LP Gas conversion:

**Conversion must be done by a qualified service technician.**

No attempt shall be made to convert the appliance from the gas specified on the model/serial rating plate for use with a different gas without consulting the serving gas supplier. See "Gas Conversions" section.

### Gas Supply Line

- Provide a gas supply line of ¾" rigid pipe to the range location. A smaller size pipe on longer runs may result in insufficient gas supply. Pipe joint compounds that resist the action of LP gas must be used. Do not use TEFLON<sup>®</sup> tape. With LP gas, piping or tubing size can be ½" minimum. Usually, LP gas suppliers determine the size and materials used in the system.

### Flexible metal appliance connector:

- If local codes permit, a new CSA design-certified, 4-5 ft (122-152.4 cm) long, ½" (1.3 cm) or ¾" (1.9 cm) I.D., flexible metal appliance connector may be used for connecting range to the gas supply line.

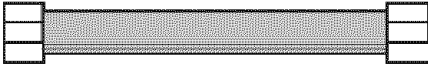

- A ½" (1.3 cm) male pipe thread is needed for connection to the female pipe threads of the inlet to the appliance gas pressure regulator.
- Do not kink or damage the flexible metal tubing when moving the range.

### Rigid pipe connection:

The rigid pipe connection requires a combination of pipe fittings to obtain an in-line connection to the range. The rigid pipe must be level with the range connection. All strains must be removed from the supply and fuel lines so range will be level and in line.

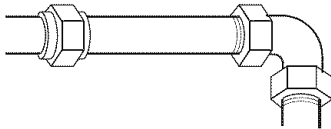

- Must include a shutoff valve:

The supply line must be equipped with a manual shutoff valve. This valve should be located in the same room but external to the range. It should be in a location that allows ease of opening and closing. Do not block access to shutoff valve. The valve is for turning on or shutting off gas to the range.

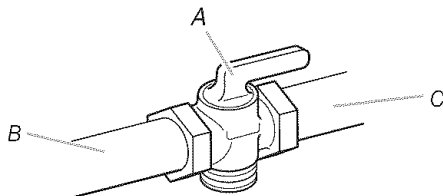

A. Shutoff valve in "open" position  
B. Gas supply line  
C. To range

### Burner Input Requirements

Input ratings shown on the model/serial rating plate are for elevations up to 2,000 ft (609.6 m).

For elevations above 2,000 ft (609.6 m), ratings are reduced at a rate of 4% for each 1,000 ft (304.8 m) above sea level.

### Gas Supply Pressure Testing

#### Line pressure testing above ½ psi gauge (14" WCP)

The range and its individual manual shutoff valve must be disconnected from the gas supply piping system during any pressure testing of that system at test pressures greater than ½ psi (3.5 kPa).

#### Line pressure testing at ½ psi gauge (14" WCP) or lower

The range must be isolated from the gas supply piping system by closing its individual manual shutoff valve during any pressure testing of that system at test pressures equal to or less than ½ psi (3.5 kPa).

### Gas Pressure Regulator

The gas pressure regulator supplied with this range must be used. The inlet pressure to the regulator should be as follows for proper operation:

#### Natural Gas:

Minimum pressure: 5" WCP

Maximum pressure: 14" WCP

#### LP Gas:

Minimum pressure: 11" WCP

Maximum pressure: 14" WCP

Contact local gas supplier if you are not sure about the inlet pressure.

†®TEFLON is a registered trademark of E.I. Du Pont De Nemours and Company.

# INSTALLATION INSTRUCTIONS

## Unpack Range

### **! WARNING**

#### **Excessive Weight Hazard**

**Use two or more people to move and install range.**  
**Failure to do so can result in back or other injury.**

1. Do not use oven door handle to lift or move the range.
2. Remove shipping materials, tape and protective film from range. Keep cardboard bottom under range. Remove oven racks and parts package from inside oven.
3. Take 4 cardboard corners from the carton. Stack one cardboard corner on top of another. Repeat with the other 2 corners. Place them lengthwise on the floor behind the range to support the range when it is laid on its back. Using 2 or more people, firmly grasp the range and gently lay it on its back on the cardboard corners.
4. Pull cardboard bottom firmly to remove.
5. Use an adjustable wrench to loosen the leveling legs. Adjust the leveling legs to the correct height. Leveling legs can be loosened to add up to a maximum of 1" (2.5 cm). A maximum of 3/16" (5 mm) is needed to engage the anti-tip bracket.

NOTE: If height adjustment is made when range is standing, tilt the range back to adjust the front legs, then tilt forward to adjust the rear legs.

6. Place cardboard or hardboard in front of range. Using 2 or more people, stand range back up onto cardboard or hardboard.

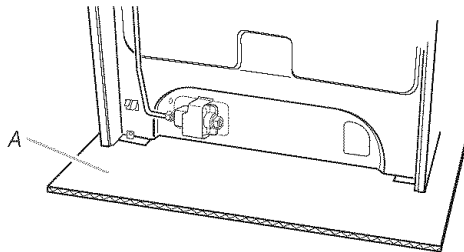

A. Cardboard shipping base

## Install Anti-Tip Bracket

### **! WARNING**

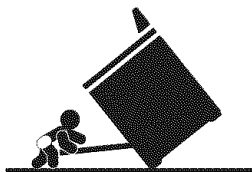

#### **Tip Over Hazard**

**A child or adult can tip the range and be killed.**  
**Connect anti-tip bracket to rear range foot.**  
**Reconnect the anti-tip bracket, if the range is moved.**  
**Failure to follow these instructions can result in death or serious burns to children and adults.**

Contact a qualified floor covering installer for the best procedure for drilling mounting holes through your type floor covering.

Before moving range, slide range onto shipping base, cardboard or hardboard.

1. Remove template from the anti-tip bracket kit (found inside the oven cavity).
2. Place template on the floor in the cabinet opening so that the left edge is against the cabinet and the top edge is against the rear wall, molding or cabinet.
3. Tape template in place.
4. If the countertop is not flush with the cabinet opening edge, align the template with the overhang.

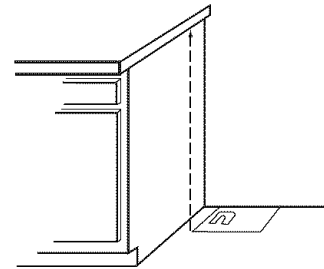

If the cabinet opening is wider than specified in the "Location Requirements" section, adjust the template so the range will be centered in the cabinet opening.

5. To mount the anti-tip bracket to a wood floor, drill two 1/8" (3.2 mm) holes at the positions marked on the bracket template. Remove the template from the floor.

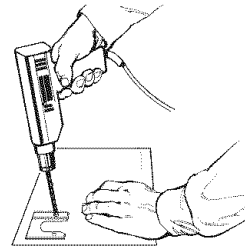

To mount the anti-tip bracket to a concrete or ceramic floor, use a 3/16" (4.8 mm) masonry drill bit to drill 2 holes at the positions marked on the bracket template. Remove the template from the floor.

6. Tap plastic anchors into holes with a hammer.
7. Align the anti-tip bracket holes with the holes in the floor. Fasten the anti-tip bracket with the screws provided.

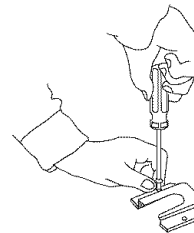

Depending on the thickness of your flooring, longer screws may be necessary to anchor the bracket to the subfloor. Longer screws are available from your local hardware store.



8. Move the range close to the opening. Remove the shipping base, cardboard or hardboard from under the range.
9. Open the broiler door. Use a 3/8" drive ratchet to lower the rear leveling legs one-half turn. Use flip-joint pliers to lower the front leveling legs one-half turn.

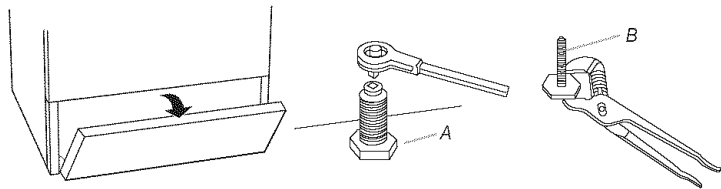

10. Adjust the leveling legs to the correct height. Leveling legs can be loosened to add up to a maximum of 1" (2.5 cm). A minimum of 3/16" (5 mm) is needed to engage the anti-tip bracket.
11. Move the range into final position making sure the rear leveling leg slides into the anti-tip bracket.

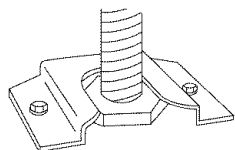

12. If installing the range in a mobile home, you must secure the range to the floor. Any method of securing the range is adequate as long as it conforms to the standards in the "Location Requirements" section.
13. Continue installing your range using the following installation instructions.

### Verify Anti-Tip Bracket Location

1. Make sure the anti-tip bracket is installed:
  - Look for the anti-tip bracket securely attached to the floor.
  - Slide the range back so the rear range foot is under the anti-tip bracket.
2. If installing the range in a mobile home, you must secure the range to the floor. Any method of securing the range is adequate as long as it conforms to the standards in the "Location Requirements" section.

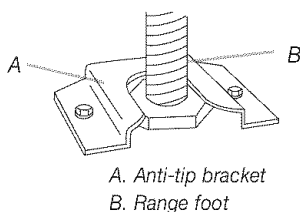

3. Continue installing your range using the following installation instructions.

### Level Range

1. Place rack in oven.
2. Place level on rack and check levelness of range, first side to side; then front to back.

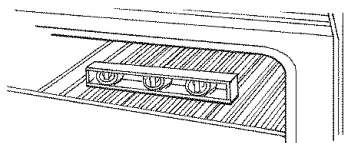

3. If range is not level, pull range forward until rear leveling leg is removed from the anti-tip bracket. Use 3/8" drive ratchet and slip-joint pliers to adjust leveling legs up or down until range is level.
  4. Push range back into position.
  5. Check that rear leveling leg is engaged in anti-tip bracket.
- NOTE:** Range must be level for satisfactory baking performance.

## Make Gas Connection

### Typical rigid pipe connection

A combination of pipe fittings must be used to connect the range to the existing gas line. Your connection may be different; according to the supply line type, size, and location.

1. Apply pipe joint compound made for use with LP gas to all pipe thread connections.
2. Using a pipe wrench to tighten, connect the gas supply to the range.

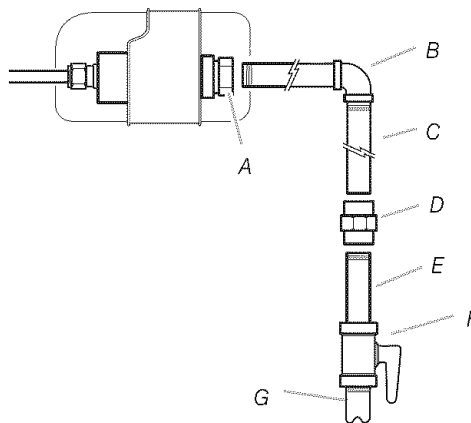

- |  |                          |
|--|--------------------------|
| A. Pressure regulator connection fitting | D. Union                 |
| B. 90° elbow                             | E. Nipple                |
| C. Black iron pipe                       | F. Manual shutoff valve  |
|  | G. 1/2" to 3/4" gas pipe |

### Typical flexible connection

1. Use a combination wrench to attach the flexible connector to the adapters. Check that connector is not kinked.

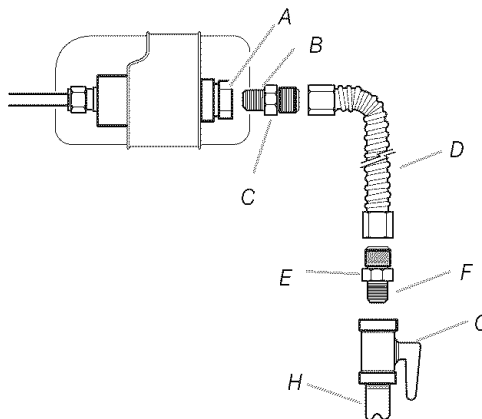

- |  |                            |
|--|----------------------------|
| A. Pressure regulator connection fitting | E. Adapter                 |
| B. Use pipe joint compound               | F. Use pipe joint compound |
| C. Adapter                               | G. Manual shutoff valve    |
| D. Flexible connector                    | H. 1/2" to 3/4" gas pipe   |

## Complete Connection

1. Locate gas pressure regulator in the broiler.

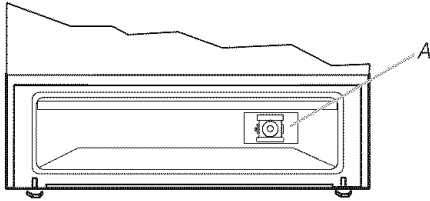

A. Gas pressure regulator

**IMPORTANT:** Do not remove the gas pressure regulator.

2. Check that the gas pressure regulator shutoff valve is in the "ON" position.

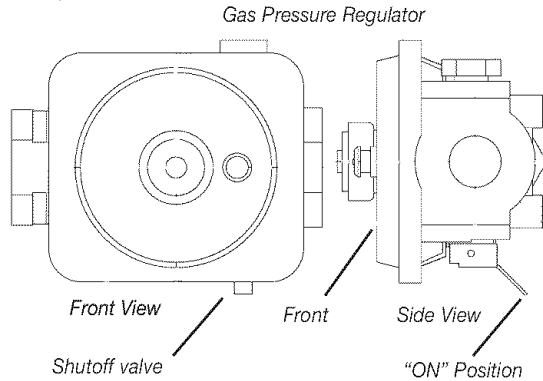

3. Open the manual shutoff valve in the gas supply line. The valve is "open" when the handle is parallel to the gas pipe.

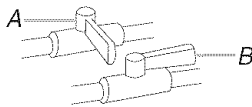

A. Closed valve  
B. Open valve

4. Test all connections by brushing on an approved noncorrosive leak-detection solution. Bubbles will show a leak. Correct any leak found.
5. Close the broiler door.
6. Place burners, burner caps and grates on the cooktop.

## ⚠ WARNING



### Electrical Shock Hazard

Plug into a grounded 3 prong outlet.

Do not remove ground prong.

Do not use an adapter.

Do not use an extension cord.

Failure to follow these instructions can result in death, fire, or electrical shock.

7. Plug into a grounded 3-prong outlet.

## Check Operation

### Electronic Ignition System

Cooktop and oven burners use electronic ignitors in place of standing pilots. When a cooktop control knob is turned to the "LITE" position, the system creates a spark to light the burner. This sparking continues until the control knob is turned to the desired setting.

When the oven control is turned to the desired setting, a hot surface ignitor heats to a bright orange and ignites the gas. No sparking occurs. The glow bar remains on while the burner operates.

### Check Operation of Cooktop Burners

1. If control panel and knobs were removed earlier, reinstall knobs.
2. Push in and turn each surface unit control knob to "LITE" position. The flame should light within 4 seconds.
3. Turn control knob to "HI" position after burner lights.
4. Check each cooktop burner for proper flame. The small inner cone should have a very distinct blue flame  $\frac{1}{4}$ " (6.4 mm) to  $\frac{1}{2}$ " (13 mm) long. The outer cone is not as distinct as the inner cone.

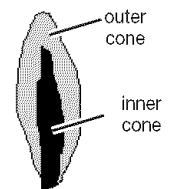
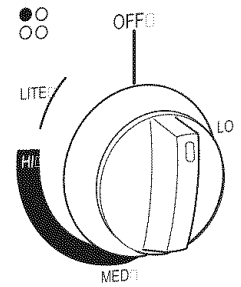

5. Turn the control knob quickly to the "LO" position after the burner lights. If the flame goes out, turn the control knob to the "OFF" position.
6. Check each cooktop burner for proper low flame. The low flame should be a minimum, steady blue flame. The flame size should be  $\frac{1}{4}$ " to  $\frac{3}{8}$ " (6.4 mm to 9.5 mm) high.

#### If the low flame needs adjusting:

1. Turn control knob to the "LO" setting and remove control knob.
2. Insert a small flat-blade screwdriver into the valve stem. Turn the valve adjusting screw to obtain the smallest flame that will not go out when the control of a cold burner is quickly turned from "HI" to "LO". Turn right to decrease flame height. Turn left to increase flame height. Repeat for other cooktop burners as needed.

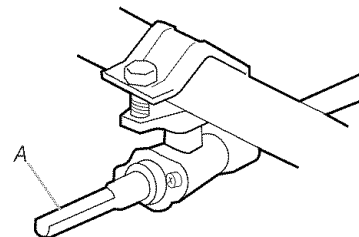

A. Valve stem

3. Replace control knob.

## Check Operation of Oven/Broil Burner

1. Open broiler door.
2. Push in and turn the oven control knob to "350°F." The oven pilot should now be larger with the flame burning against a small metal bulb. The oven burner should light in 20–40 seconds; this delay is normal. The oven valve requires a certain time before it will open and allow gas to flow.

To avoid damaging the hot surface ignitor, do not insert any object into the openings of the protective shield that surrounds the ignitor or clean that area.

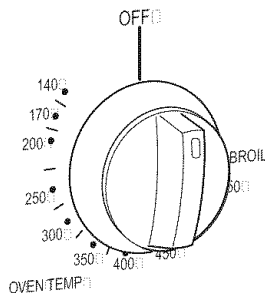

3. Check the oven burner for proper flame. The flame should be ½" (13 mm) long, with inner cone of bluish-green, and outer mantle of dark blue, and should be clean and soft in character. No yellow tips (not enough air), blowing or lifting (too much air) of flame should occur.

### If the flame needs adjusting:

1. Turn the oven off. Wait for the oven burner to cool down.
2. Open oven door and remove oven racks, oven tray, flame spreader and set aside.

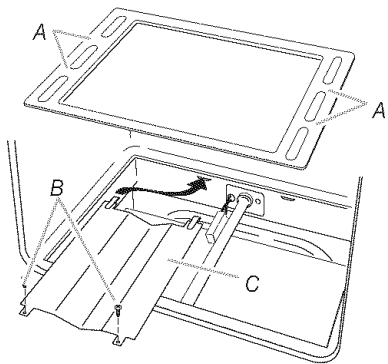

A. Oven tray (lift up at area shown to remove)  
B. Screws  
C. Flame spreader

3. Locate the air shutter near the rear wall of oven and loosen the shutter screw.

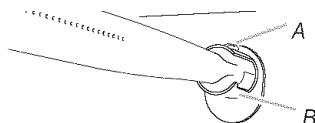

A. Shutter screw  
B. Air shutter

4. Adjust the air shutter.

5. Turn the oven back on and check for proper flame. If the flame is still not properly adjusted, turn the oven off, wait for the oven burner to cool down and repeat step 4 until flame is properly adjusted.
6. When the flame has been properly adjusted, turn the oven off, wait for the burner to cool down.
7. Tighten the shutter screw.
8. Reinstall flame spreader and oven tray. Reinstall the oven racks and close oven door.
9. Close the broiler door.

## Complete Installation

1. Check to be sure all parts are now installed. If there is an extra part, go back through the steps to see which step was skipped.
2. Check to be sure you have all of your tools.
3. Dispose of/recycle all packaging materials.
4. Check to be sure the range is level. See "Level Range."
5. Use a mild solution of liquid household cleaner and warm water to remove waxy residue caused by protective shipping material. Dry thoroughly with a soft cloth.
6. For range use and cleaning, read the range Use and Care Guide.
7. Turn on surface burners and oven.

### If range does not operate, check the following:

- Household fuse is intact and tight; or circuit breaker has not tripped.
- Range is plugged in to a grounded 3 prong outlet.
- Electrical supply is connected.
- See "Troubleshooting" in your Use and Care Guide.
- When the range has been on for 5 minutes, feel for heat. If you do not feel heat, turn the range off and check to see that the gas supply line shutoff valve is open.
  - If the gas supply line shutoff valve is closed, open it, then repeat the 5-minute test as outlined above.
  - If the gas supply line shutoff valve is open, contact a qualified technician.

# GAS CONVERSIONS

## ⚠ WARNING



### Explosion Hazard

Use a new CSA International approved gas supply line.

Install a shut-off valve.

Securely tighten all gas connections.

If connected to LP, have a qualified person make sure gas pressure does not exceed 14" (36 cm) water column.

Examples of a qualified person include:

licensed heating personnel,  
authorized gas company personnel, and  
authorized service personnel.

Failure to do so can result in death, explosion, or fire.

**NOTE:** Gas conversions (from natural gas to LP gas or from LP gas to natural gas) must be done by a qualified person.

## LP Gas Conversion

## ⚠ WARNING

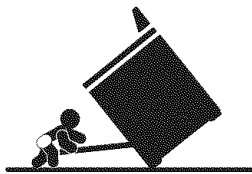

### Tip Over Hazard

A child or adult can tip the range and be killed.

Connect anti-tip bracket to rear range foot.

Reconnect the anti-tip bracket, if the range is moved.

Failure to follow these instructions can result in death or serious burns to children and adults.

## To Convert Gas Pressure Regulator

1. Ensure that the manual shutoff valve is in the closed position.

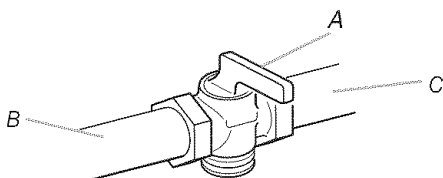

A. Shutoff valve in "closed" position  
B. Gas supply line  
C. To range

2. Unplug or disconnect power.
3. Open broiler door and remove broiler pan. The gas pressure regulator is located in the back right hand corner of the broiler compartment.

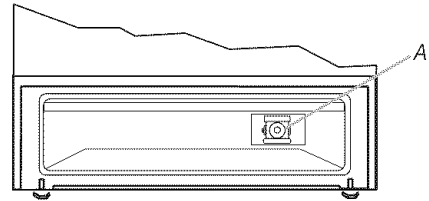

A. Gas pressure regulator

**IMPORTANT:** Do not remove the gas pressure regulator.

**NOTE:** Do not remove the spring beneath the cap.

4. Remove the cap from the gas pressure regulator using a flat-blade screwdriver.

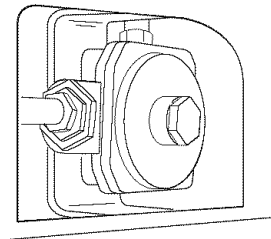

5. Turn the cap over so that LP is visible.

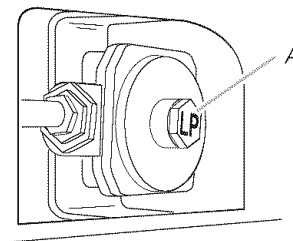

A. Cap

6. Reinstall the cap.

## To Convert Surface Burners

1. Remove burner grate, burner caps, and burners.

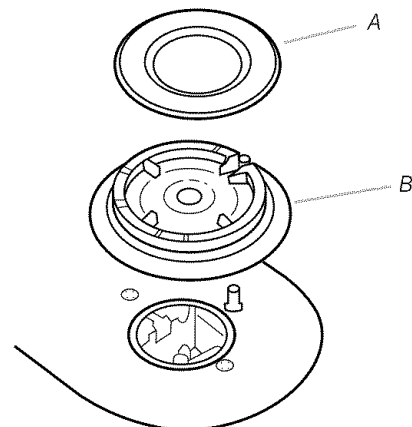

A. Burner cap  
B. Burner

2. Locate LP gas orifice spuds for top burners in the bag containing literature included with the range. Three LP gas spuds are stamped "88" and one "96."
3. Remove natural gas orifice spuds using a 7mm combination wrench.
4. Install LP gas orifice spuds.

**NOTE:** Depending on model, the range cooktop may be equipped with 4 standard burners or 3 standard burners and 1 power burner. Spud size/location remain the same.

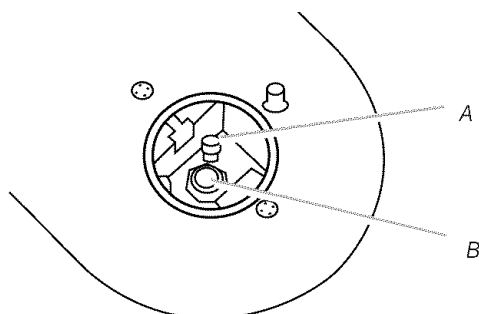

A. Spud  
B. Holder

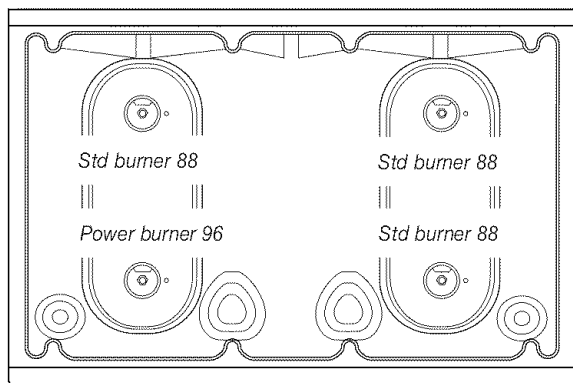

5. Place the natural gas orifice spuds in the parts bag for future use and keep with bag containing literature.
6. Reinstall burners, burner caps and burner grates.

## To Convert Oven Burner

1. Open oven door and remove oven racks, oven tray, flame spreader and set aside.
2. Lift oven burner. The orifice spud is behind the oven burner air shutter.

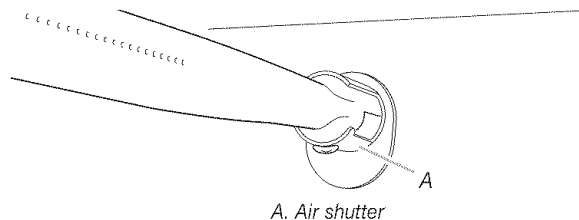

3. Locate LP gas orifice spud stamped "56" in literature package supplied with range.
4. Use a 3/8" combination wrench and remove the natural gas orifice spud.
5. Install the number "56" LP gas spud.

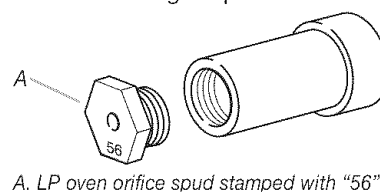

A. LP oven orifice spud stamped with "56"

**IMPORTANT:** Do not over tighten.

6. Place natural gas oven burner spud in plastic parts bag along with natural gas cooktop burner spuds for future use and keep with bag containing literature.
7. Reinstall oven burner.
8. Reinstall oven racks, oven tray and flame spreader.

## Complete Conversion

1. Refer to the "Make Gas Connection" section for properly connecting the range to the gas supply.
2. Turn the manual shutoff valve in the gas supply line to the open position.
3. Refer to the "Check Operation" section for proper burner ignition, operation, and burner flame adjustments.

**IMPORTANT:** You may have to adjust the "LO" setting for each cooktop burner.

Checking for proper cooktop and oven burner flames is very important. The small inner cone should have a very distinct blue flame 1/4" to 1/2" (6.4 mm to 13 mm) long. The outer cone is not as distinct as the inner cone. LP gas flames have a slightly yellow tip.

4. Close the broiler door and turn the knob to "OFF".
5. Refer to the "Complete Installation" section to complete this procedure.

## Natural Gas Conversion

### **⚠ WARNING**

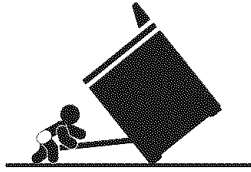

#### Tip Over Hazard

A child or adult can tip the range and be killed.

Connect anti-tip bracket to rear range foot.

Reconnect the anti-tip bracket, if the range is moved.

Failure to follow these instructions can result in death or serious burns to children and adults.

### To Convert Gas Pressure Regulator

1. Ensure that the manual shutoff valve is in the closed position.

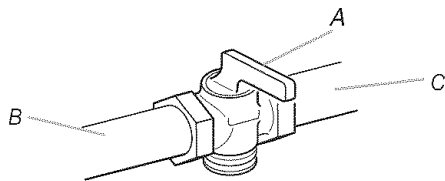

- A. Shutoff valve in "closed" position
- B. Gas supply line
- C. To range

2. Unplug or disconnect power.
3. Open broiler door and remove broiler pan. The gas pressure regulator is located in the back right hand corner of the broiler compartment.

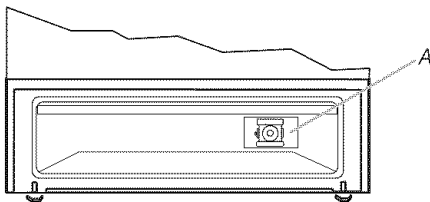

A. Gas pressure regulator

**IMPORTANT:** Do not remove the gas pressure regulator.

**NOTE:** Do not remove the spring beneath the cap.

4. Remove the cap from the gas pressure regulator using a flat-blade screwdriver.

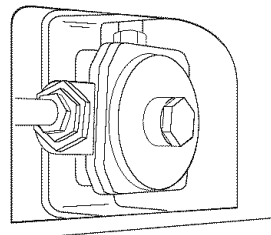

5. Turn the cap over so that N or NAT is visible.

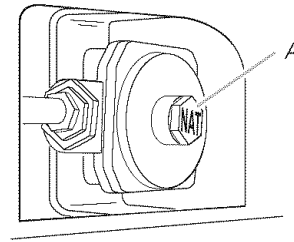

A. Cap

6. Reinstall the cap.

### To Convert Surface Burners

1. Remove burner grates, burner caps, and burners.

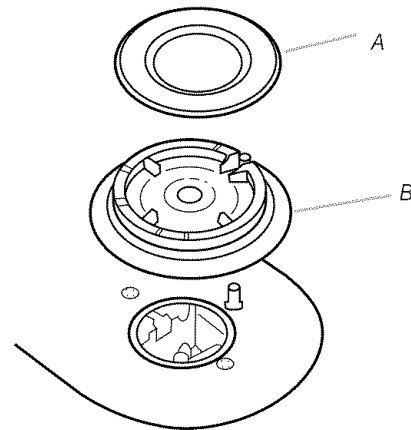

A. Burner cap  
B. Burner

2. Locate the natural gas orifice spuds for the top burners in the bag containing literature included with the range. Three natural gas spuds are stamped "149" and one "165."
3. Remove the LP gas orifice spuds using a 7mm combination wrench.

4. Install natural gas orifice spuds.

**NOTE:** Depending on model, the range cooktop may be equipped with 4 standard burners or 3 standard burners and 1 power burner. Spud size/location remain the same.

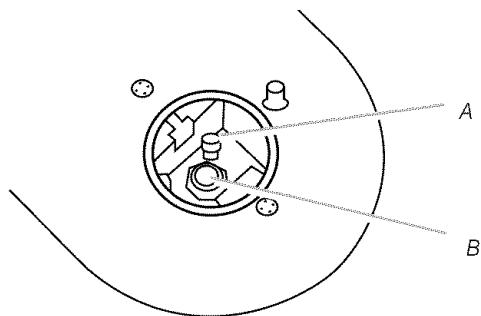
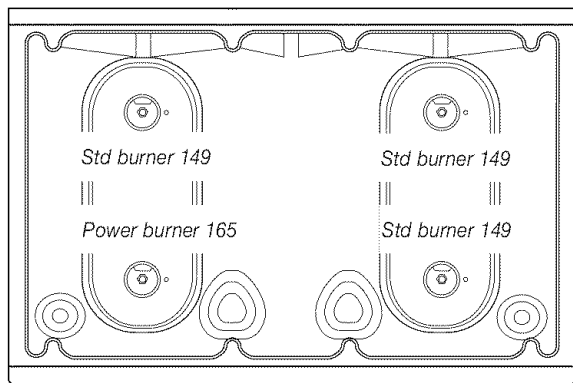

A. Spud  
B. Holder

5. Place LP gas orifice spuds in the plastic parts bag for future use and keep with the bag containing literature.
6. Reinstall burners, burner caps and burner grates.

---

### To Convert Oven Burner

---

1. Open oven door and remove oven racks, oven tray, flame spreader and set aside.
2. Lift oven burner. The orifice spud is behind the oven burner air shutter.

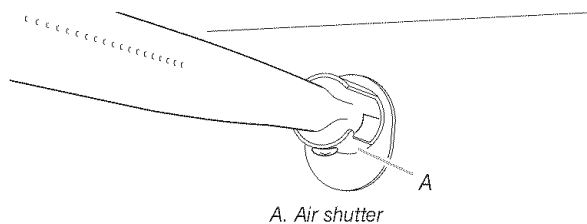

A. Air shutter

3. Locate natural gas orifice spud stamped "47" in literature package supplied with range.

4. Use a 3/8" combination wrench and remove the LP gas orifice spud.

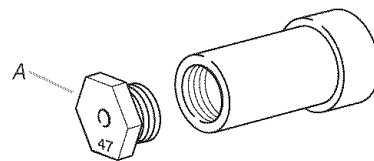

A. Natural gas oven orifice spud stamped with "47"

5. Install the number "47" natural gas spud.

**IMPORTANT:** Do not over tighten.

6. Place LP gas oven burner spud in plastic parts bag along with LP gas cooktop burner spuds for future use and keep with bag containing literature.
7. Reinstall oven burner.
8. Reinstall oven racks, oven tray and flame spreader.

### Complete Conversion

1. Refer to the "Make Gas Connection" section for properly connecting the range to the gas supply.
2. Turn the manual shutoff valve in the gas supply line to the open position.
3. Refer to the "Check Operation" section for proper burner ignition, operation, and burner flame adjustments.

**IMPORTANT:** You may have to adjust the "LO" setting for each cooktop burner.

Checking for proper cooktop and oven burner flames is very important. The small inner cone should have a very distinct blue flame 1/4" to 1/2" (6.4 mm to 13 mm long). The outer cone is not as distinct as the inner cone. Natural gas flames do not have yellow tips.

4. Close the broiler door and press the "OFF" pad.
  5. Refer to the "Complete Installation" section to complete this procedure.
-

**W10130752A**

©2007 Whirlpool Corporation  
All rights reserved.

Printed in Mexico  
03/2007