

OWNER'S MANUAL

DieHard®

BATTERY CHARGER
60/20/2 Amp
Fully Automatic

275/125 AMP
ENGINE STARTER
With Battery Tester and
GFCI Outlets

Model No.
200.71234



CAUTION:
Read all Safety Rules and Operating Instructions,
and follow them with each use of this product.

Sears, Roebuck and Co., Hoffman Estates, IL 60179 U.S.A.

00-99-000539/0206

Table Of Contents

| | | | |
|--|---|--------------------------------------|-----------|
| Warranty | 1 | Using Your Battery Charger | 7 |
| Important Safety Instructions | 2 | Setting the controls | 7 |
| Parts | 3 | Charging your battery | 9 |
| Wiring Diagram | 3 | Calculating charge times | 11 |
| Before Using Your Battery Charger | 4 | Using the engine start feature | 12 |
| Assembling your charger | 4 | Maintenance and care | 12 |
| Plugging it in | 5 | Troubleshooting | 13 |
| Using the GFCI outlets | 6 | | |
| Using an extension cord | 6 | | |
| Preparing your battery to be charged | 6 | | |

Please read this Manual before using your Battery Charger

The DieHard model 71234 Automatic Battery Charger/Engine Starter and Battery Tester with GFCI outlets, offers a wide range of features to accommodate the needs for home or light commercial use. This manual will show you how to use your charger safely and effectively. Please read and follow these instructions and precautions carefully.

For information about troubleshooting, call toll-free from anywhere in the U.S.A. 7 am to 4:30 pm Central Time Monday through Friday.

1-800-SEARS-64 (1-800-732-7764).

Warranty

THREE-YEAR FULL WARRANTY

If this Battery Charger fails due to a defect in material or workmanship within three years from the date of purchase, RETURN IT TO ANY SEARS STORE or OTHER DIEHARD OUTLET IN THE UNITED STATES FOR FREE REPLACEMENT.

This warranty gives you specific legal rights, and you may also have other rights which vary from state to state.

Sears, Roebuck and Co.
Hoffman Estates, IL 60179

Important Safety Instructions

– SAVE THESE INSTRUCTIONS –



WARNING

To reduce the risk of explosion, explosive gases, or injury while using your battery charger, follow the precautions listed below:

- Read **all** instructions and cautions printed on the battery charger, battery, and vehicle or equipment using battery.
- Use charger only on **lead-acid** type rechargeable batteries, such as those used in cars, trucks, tractors, airplanes, vans, RV's, trolling motors, etc. This charger is not intended to supply power to a low voltage electrical system other than in an automotive application.
- **Use only** attachments recommended or sold by manufacturer. The use of attachments not recommended by the manufacturer may result in fire, electric shock, or injury.
- **Do not** disassemble charger. Take it to a qualified service professional if service or repair is required. Incorrect assembly may result in fire or electrical shock.
- To reduce risk of electrical shock, **unplug** the charger from the outlet before attempting any maintenance or cleaning.
- **Always** charge battery in a well ventilated area.

Help us help you

Remember:

- **Place** charger as far away from battery being charged as the charger cables will permit.
- **Do not** expose charger to rain or snow.
- **Never** charge a frozen battery. If battery fluid (electrolyte) becomes frozen, bring battery into a warm area to thaw before you begin charging.
- **Never** allow battery acid to drip on charger when reading specific gravity or filling battery.
- **Never** set a battery on top of the charger.
- **Never** place charger directly above battery being charged. The gases from the battery will corrode and damage the charger.
- **Never** use charger for charging dry-cell batteries that are commonly used with home appliances. These batteries may burst and cause personal injury.
- **Never** touch the battery clamps together when the charger is energized.
- **Never** operate charger if it has received a hard blow, been dropped, or otherwise damaged. Take it to a qualified professional for inspection and repair.
- **Be sure** to position the charger power cord to prevent it from being stepped on, tripped over, or damaged.
- **Never** pull out the plug by the cord when unplugging the charger. Pulling on the cord may cause damage to the cord or the plug.
- **Do not** operate the charger if it has a damaged power cord or plug. Have the cord replaced.
- **Wear complete eye and clothing protection** when working with lead-acid batteries.
- **Be sure** that someone is within range of your voice to come to your aid if needed while you work with or are near a lead-acid battery.
- **Have plenty of fresh water and soap** nearby for use in case battery acid contacts your eyes, skin, or clothing. If this happens, wash immediately with soap and water. Then get medical attention.
- **Avoid touching your eyes** while working with a battery. Acid particles (corrosion) may get into your eyes. If this occurs, flush eyes immediately with running cold water for at least 10 minutes. Then immediately get medical attention.
- **Remove all personal metal items** from your body, such as rings, bracelets, necklaces, and watches while working with a lead-acid battery. A battery can produce a short circuit current high enough to weld a ring (or the like) to metal, causing a severe burn.
- **Take care** not to drop any metal tool or metal object onto the battery. This may spark or short circuit the battery or another electrical device that may cause an explosion.
- **Always** operate your battery charger in an open, well ventilated area.
- **Never** smoke or allow a spark or flame in the vicinity of the battery or engine. Batteries generate explosive gases.
- **Neutralize** any acid spills thoroughly with baking soda before attempting to clean up.
- **WARNING:** Handling the cord on this product or cords associated with accessories sold with this product, may expose you to lead, a chemical known to the State of California to cause cancer and birth defects or other reproductive harm. **Wash hands after handling.**

Personal Safety Precautions

For your own personal safety, please follow the following precautions:

Parts

This section shows an illustration of your battery charger. Use it to become familiar with where all the parts are located, and what they look like.

| Replacement Parts List DieHard 71234 | | |
|--------------------------------------|---------------------------------|-------------|
| ITEM | DESCRIPTION | PART NUMBER |
| 1 | Plastic Top | 3799004100 |
| 2 | Rocker Switch SPST | 0499000050 |
| 3 | Rocker Switch DPDT | 0499000053 |
| 4 | Control Board Assembly | 2299001465 |
| 5 | Faceplate | 0899002622 |
| 6 | Handle | 3599000262 |
| 7 | Receptacle, GFCI, 15A | 0099000587 |
| 8 | Circuit Breaker | 3999000108 |
| 9 | Positive (RED) Cable w/clamps | 3899001165 |
| 10 | Negative (BLACK) Cable w/clamps | 3899001164 |
| 11 | Power Cord | 90026177 |
| 12 | Power Board/Heatsink Assembly | 2299001467 |
| 13 | Transformer | 93026585 |
| 14 | Fan Motor | 0099000604 |
| 15 | Hardware Kit | 2299001078 |
| 16 | Wheel | 0099000120 |
| 17 | Handle Grip | 0399000018 |
| 18 | Mounting Foot | 1199005112 |
| 19 | Axle | 0099000066 |
| 20 | Owner's Manual | 0099000539 |

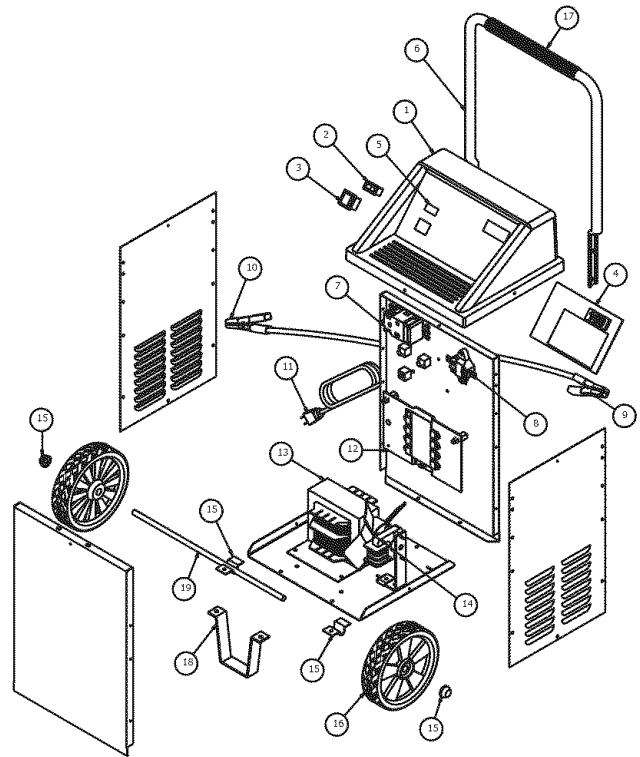

Wiring Diagram

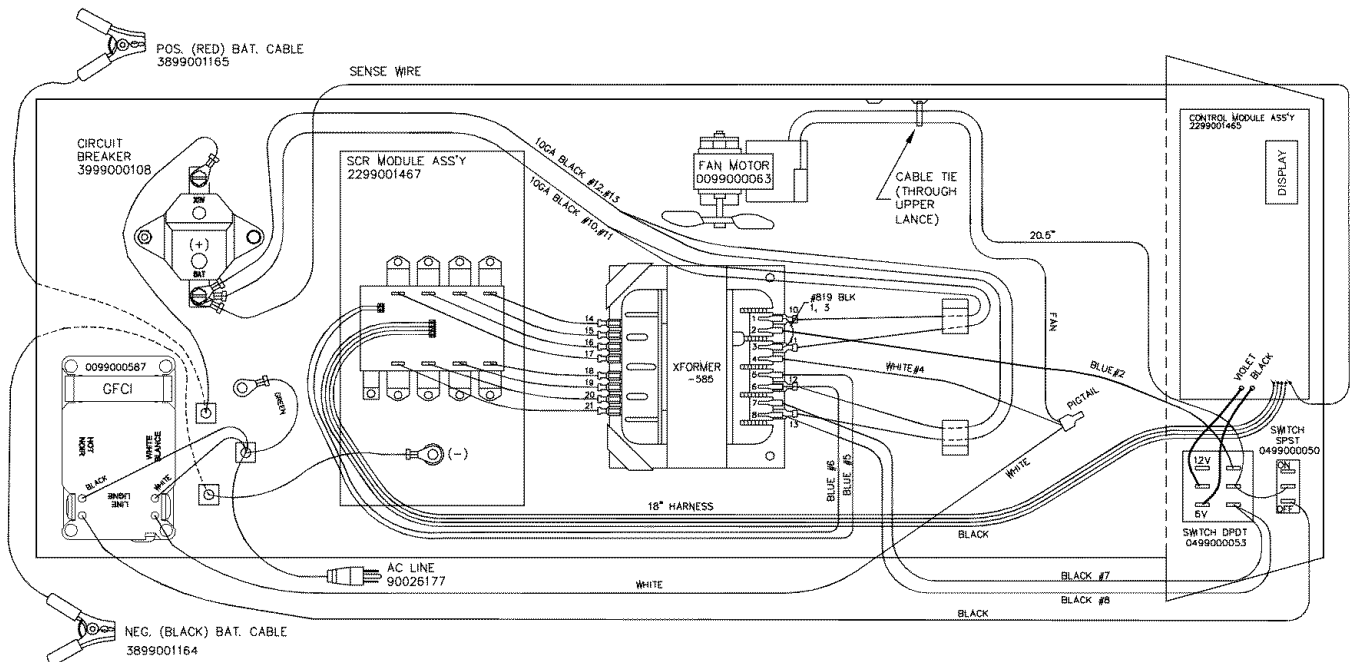

Before Using Your Battery Charger

It is important to prepare your charger for use. This section will tell you how to assemble the charger, ground and connect the power cord, and prepare to charge a battery.

Assembling your charger

It is important to fully assemble your charger before use. Follow these instructions for easy assembly.

| PARTS: | TOOLS NEEDED: |
|-----------------------------------|------------------------------------|
| Two, 10-32 thread cutting screws | 3/8" wrench (for mounting foot) |
| Two, 1/4-20 thread cutting screws | 5/16" wrench (for wheels) |
| Two wheels | Hammer |
| One axle | Phillips screwdriver |
| Two axle caps | |
| Two axle brackets | |
| One handle | |
| One handle grip | |
| One mounting foot | |

Attach Foot:

Remove charger from packing materials and place charger on its side. Attach mounting foot and secure with the two, 1/4-20 thread cutting screws provided.

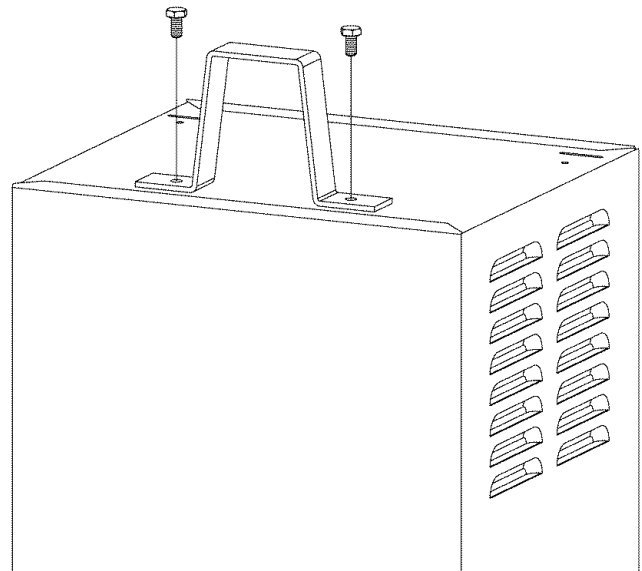

Axle Assembly:

Hold axle upright on floor or work surface. Then, using a hammer, tap one of the axle caps onto the top end of the axle. Be sure to tap the hub on straight. Slide both wheels onto the axle with the hubs facing inward. Tap the other axle cap onto the opposite end of the axle and place the axle assembly onto the bottom of the charger.

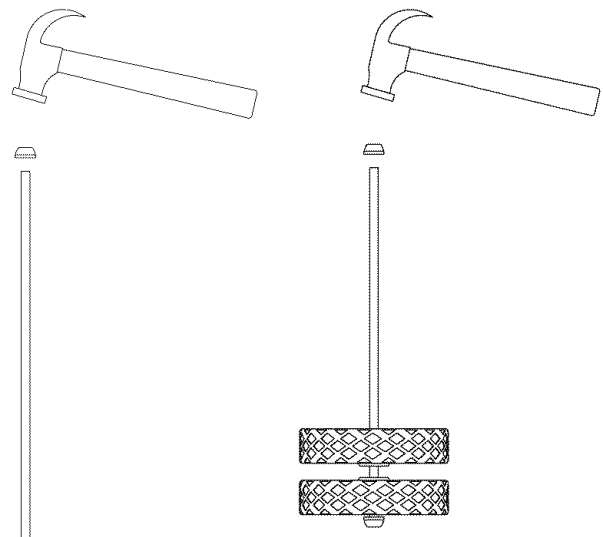

continued on next page

Axle Assembly (continued):

Place the charger on its side. Place one end of each bracket into slot, then place the axle assembly under each bracket. Fasten the other side of each bracket using the two, 10-32 thread cutting screws provided.

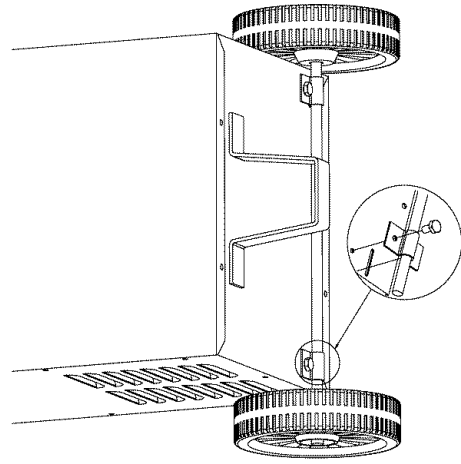

Handle:

Turn the charger right side up onto its foot and wheels. Remove the two top screws from each side of the charger. Slide handle grip over handle tubing. Align the handle so the screw holes are aligned with the screw holes on each side of the wheel charger. Attach handle using the same screws.

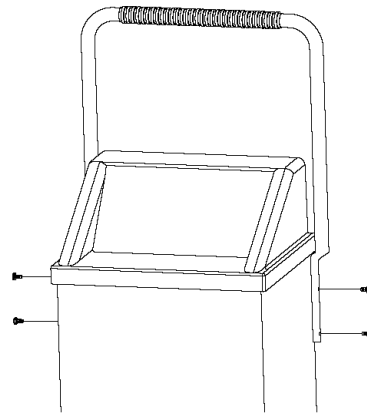

Plugging it in

⚠ WARNING

Electrical Shock Hazard

Be sure that power cord fits properly into outlet. If not, have a qualified technician install a proper outlet. Never alter the AC cord or plug provided. Improper connection can result in electrical shock.

Your charger should be grounded to reduce the risk of electrical shock.

Your charger is equipped with an electrical cord that has an equipment grounding conductor and a ground-plug designed to be used on a 120V circuit. The plug must be plugged into an outlet that has been properly installed and grounded in accordance with all local codes and ordinances.

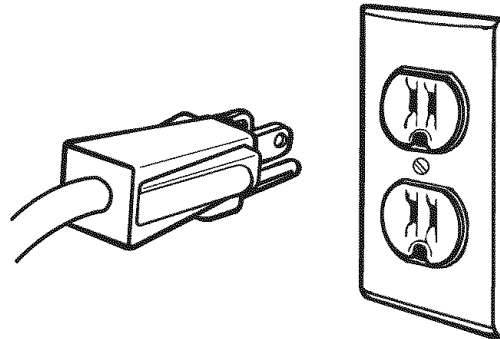

A 3-Prong Grounded Wall Outlet

This Battery Charger includes GFCI protected outlets. Proper grounding is required for correct GFCI operation.

⚠ WARNING

DO NOT exceed 15 Amps on GFCI Outlets. If using Battery Charger **DO NOT** exceed 3 Amps.

Using the GFCI Outlet

- This charger includes two – GFCI (Ground Fault Circuit Interrupter) outlets located on its back. The purpose of a GFCI outlet is to quickly stop the flow of electricity in the event a ground fault occurs on the device plugged into the battery charger's GFCI outlet. Ground fault circuit interrupters (GFCI) can help prevent electrical shock or electrocution.
- The GFCI outlets provide auxiliary power to 120V devices that require less than 15 amps.

The GFCI must be tested before each use. To test:

1. Push the "Reset" button located on the GFCI receptacle, first to assure normal GFCI operation.
2. Plug a nightlight (with an "ON/OFF" switch) or other product (such as a lamp) into the GFCI receptacle and turn the product "ON."
3. Push the "Test" button located on the GFCI receptacle. The nightlight or other product should go "OFF."

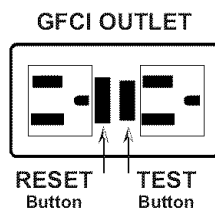

4. Push the "Reset" button, again. The light or other product should go "ON" again.

NOTE: If the light or other product remains "ON" when the "Test" button is pushed, the GFCI is not working properly and should not be used. Call Customer Service at 1-800-SEARS-64 (1-800-732-7764).

- The power cord must be plugged into a 3-prong grounded 120V AC wall outlet for the GFCI operation to function. Ground fault circuit interrupters (GFCI) can help prevent electrical shock or electrocution.
- If you are charging a battery, the GFCI outlet should be limited to 3 amps of current draw until the charging functions are complete.
- The GFCI outlet should not be used while the charger is in the ENGINE START mode.
- If using both GFCI outlets at the same time, the amperage cannot exceed 15 amps of both devices combined.

Using an extension cord

The use of an extension cord is not recommended. If you must use an extension cord, please make sure that you follow these guidelines:

- Make sure the pins on the plug of the extension cord are the same number, size, and shape as those of the plug on the charger.
- Use only 3-conductor (grounded) extension cord when necessary.
- Check that the extension cord is properly wired and in good electrical condition.

- Use the recommended minimum AWG (American Wire Gauge) to be sure that wire size is large enough for the rating of the charger.

| MINIMUM RECOMMENDED EXTENSION CORD | | | | |
|------------------------------------|----|----|-----|-----|
| Length of Cord, in Feet | 25 | 50 | 100 | 150 |
| AWG* Size of Cord | 14 | 12 | 10 | 8 |

*AWG=American Wire Gauge

Preparing your battery to be charged

It is important that you read and follow these guidelines while you are preparing to charge your battery.

- Make sure that you have a 12 volt or 6 volt lead-acid battery. Set the volt/amp selector switch to match the voltage rating of the battery to be charged.
- Clean the battery terminals. Be careful to keep corrosion from getting in or around your eyes or on your hands.
- If you have a battery with removable cell caps, if required, add distilled water to each cell until the battery acid reaches the level recommended by the manufacturer. This will help purge excessive gases from the cells. Be careful not to overfill. If you have a sealed battery without cell caps, no action is necessary. Continue to the next step listed below.
- Take time to read all battery manufacturer's specific precautions, such as removing or not removing

cell caps while charging, and recommended rates of charge.

- Wear safety glasses. See additional "Personal Safety Precautions" on page 2.
- Be sure that the area around the battery is well ventilated while it is being charged. If ventilation is poor, any gases emitted from the battery can be manually blown away by using a piece of cardboard or other non-metallic material as a fan.
- If it is necessary to remove the battery from the vehicle to charge it, always remove the grounded terminal from the battery first. A spark may be caused if all accessories in the vehicle are not completely turned off.

NOTE: A marine battery installed in a boat must be removed and charged on shore.

Using Your Battery Charger

For best results from your battery charger, learn to use it properly. This section tells how to set the controls, charge a battery in or out of the vehicle, use the ENGINE START feature and test the battery.

Setting the controls

All the controls for your charger are located on the front. Follow these instructions to obtain the accurate charge level for your battery.

POWER ON/OFF SWITCH

Make sure your charger is OFF when connecting or disconnecting your charger from the vehicle and power source. Turn your charger ON only when it is connected to the vehicle and plugged into a 3-prong grounded wall outlet.

BATTERY VOLTAGE SELECT

When charging, testing or starting 12 volt systems, select 12 VOLT. Select 6 VOLT when charging, testing or starting 6 volt systems.

TOUCH-PAD CONTROLS

With your charger connected to the vehicle and power source, the battery voltage (6 or 12 volt) selected, and the power turned ON, select either AUTOMATIC or MANUAL charge and the rate at which you want to charge your battery (2, 20, or 60 amp).

- **AUTO (Automatic):** When first turned ON, the charger will be in the Manual mode. Touch the AUTO pad and either the 2, 20, or 60 AMP Charge Rate Selector pad. Charging will start after a short delay. It will stop when the battery is fully charged. While charging, the METER will show battery voltage. Touch the VOLTS/AMPS pad to see the amount of amps being drawn by the battery.

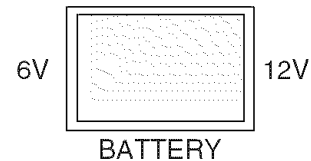
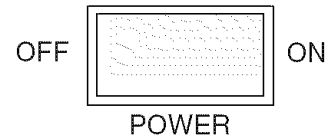

- **MANUAL:** When first turned on, the charger will be in the Manual mode - there will be no need to select MANUAL. Select a charge rate and time. The charger will start charging after a short delay. **It will stop charging only when the selected time or maximum time is up.** For this reason, it is IMPORTANT to check the charger frequently to avoid overcharging the battery. While charging, the METER will show battery voltage. To see how much of the selected charge time is remaining, touch the TIME pad. The METER will show the time and, after a short delay, return to showing voltage. To see the amount of amps being drawn by the battery, touch the VOLTS/AMPS pad.

- **TIME:** To select a charging time, you must be in the MANUAL mode and have selected a charge rate. Touch the TIME pad until the desired time shows on the meter. The following chart shows the amount of time available for each charge rate and the amount of time, in hours, added for each touch of the TIME pad.

| RATE | 2 Amps | 20 Amps | 60 Amps |
|--------------------|----------|----------|----------|
| Maximum Time | 18 Hours | 10 Hours | 5 Hours |
| Increment Settings | 1 Hour | 1 Hour | 1/2 Hour |

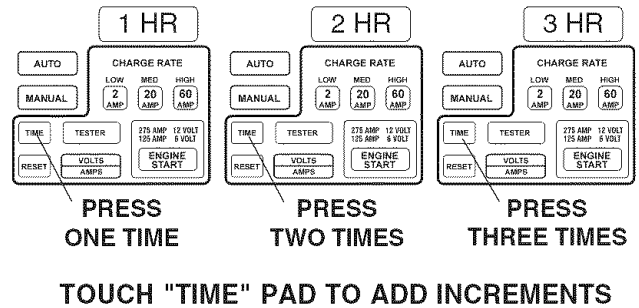

If you do not set a time, the charger will run for the maximum time. After selecting the charge rate and proper time, the charger will start charging after a short delay. To see how much time remains during the charging process, touch the TIME pad.

- **RESET:** To stop charging or to change settings once charging has begun, touch the RESET pad. Then proceed as if you've just turned on the charger.
- **VOLT/AMP:** When the charger is turned on the METER will display battery voltage. Touch the VOLTS/AMPS pad to display the charge rate in amps.
- **TESTER:** To check the battery's state-of-charge during charging, touch the RESET pad and then the TESTER pad. The METER will show the voltage of the battery. Wait about 5 minutes before taking a reading. To continue charging, proceed as if you've just turned the charger ON.
- **ENGINE START:** To use the starter feature to help crank the engine of your vehicle, touch RESET, MANUAL, and ENGINE START - in that order. Wait for the display to show RDY. The ENGINE START feature will deliver 275 amps to help crank a 12-volt system or 125 amps to help crank a 6-volt system. Crank the engine for **no more than 5 seconds**. If it does not start, **wait three minutes** before cranking again. During extremely cold weather, or if the battery is severely exhausted, charge the battery for about 5 minutes in the 60 AMP setting before cranking the engine.

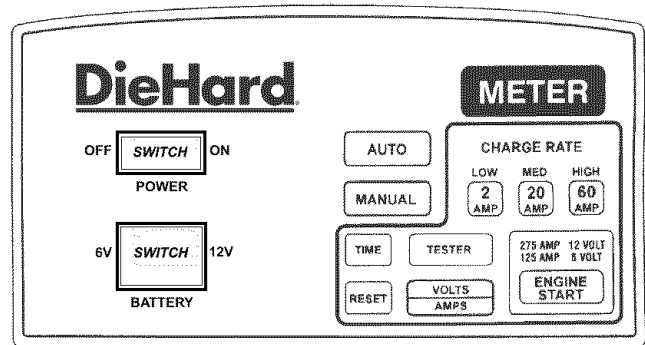

CAUTION: DO NOT try to crank an engine without a battery installed. You may damage the vehicle's electrical system.

- **METER:** Besides showing amps, volts, and time, the meter displays information:

| | |
|----------|---|
| —A— | Charge Rate in amps |
| —V— | Voltage |
| MAN | Charger is in Manual mode |
| AUTO | Charger is in Automatic mode |
| RDY | Charger is ready for cranking (Engine Start) |
| WAIT | Wait until the charger is ready before cranking again |
| FULL | Battery is charged (Automatic mode) |
| OFF | Time has expired (Manual or Timer mode) |
| HR | Hour(s) |
| CHK BATT | There is a problem with the battery or connections |
| OL | Too high a charging rate; lower rate to continue |

Charging Your Battery

NOTE: A marine (boat) battery must be removed and charged on shore. To charge it on board requires equipment specially designed for marine use.

Charging your battery in the vehicle:

1. Arrange the power cord and charging leads carefully in order to avoid damage that could be caused by the hood, door, or moving engine parts.
2. Keep hands, hair, clothing and jewelry clear of the fan blades, belts, pulleys, and other parts that can cause injury.
3. Check the polarity of the battery posts using the identification marks on the battery case: POSITIVE (POS, P, +) and NEGATIVE (NEG, N, -).
4. Identify which battery post is grounded or connected to the chassis. **THE NEGATIVE POST IS NORMALLY THE ONE THAT IS GROUNDED.**
5. **To charge a negative grounded post system:** Connect the red (POSITIVE) charger clamp to the ungrounded POSITIVE (POS, P, +) post of the battery. Next, connect the black (NEGATIVE) clamp to an unpainted, heavy metal part of the chassis or engine block, away from the battery. Do not connect clamp to carburetor, fuel lines, or sheet metal parts.

To charge a positive grounded post system: Connect the black (NEGATIVE) charger clamp to the ungrounded NEGATIVE (NEG, N, -) post of the battery. Then connect the red (POSITIVE) clamp to an unpainted, heavy metal part of the

chassis or engine block, away from the battery. Do not connect clamp to carburetor, fuel lines or sheet metal parts.

IMPORTANT: Wear safety glasses and face away from the battery while making connections.

6. Twist or rock clamps back and forth to make a solid connection. This will help make better contact and help keep them from slipping off and causing sparks.
7. Make sure the POWER switch is set to the OFF position. Next plug the power cord into a 3-prong grounded 120V AC electrical wall outlet.

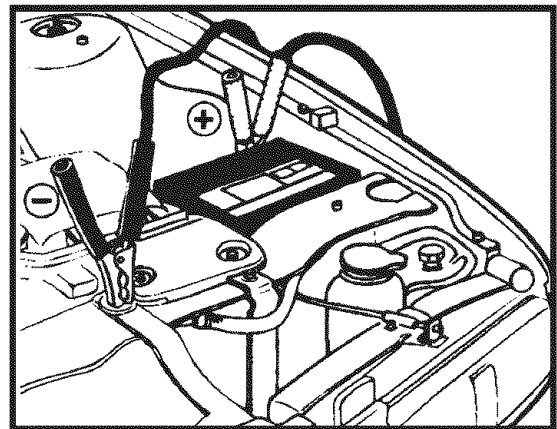

NEGATIVE GROUNDED SYSTEM

8. For automatic charging, touch AUTO then a charge-rate pad 2, 20, or 60 Amps. The charging will stop when the battery is fully charged.
 9. For manual charging, touch a charge rate pad then select a charge time up to 18 hours. If more than 18 hours of charging time is needed, reset the time when the original time runs out. Refer to the Time Chart in the "Setting the Controls" on page 8 of "Using your Battery Charger."
 10. In the MANUAL mode, at the 60-Amp charging rate, the METER will show a charge rate of 25 to 30 amps or less when the battery is at or near full charge. At the 20-Amp charging rate, the METER will show a charge rate of 8 to 10 amps or less when the battery is at or near full charge. At the 2-Amp charging rate, the METER will show a charge rate of .75 to 1 amp when the battery is at or near full charge.
 11. TO AVOID OVERCHARGING in the Manual mode, monitor the METER frequently.
 12. When the battery is fully charged, turn the POWER switch to the OFF position and unplug the charger power cord from the wall outlet.
 13. Facing away from the battery, remove the charger clamps in this order: (1) from the chassis connection and, (2) from the battery post or terminal.
 14. Clean and store the battery charger in a dry location.
6. Make sure the POWER switch is set to the OFF position. Next plug the power cord into a grounded AC outlet.
 7. For automatic charging, touch AUTO then a charge-rate pad. The charger will quit when the battery is fully charged.
 8. For manual charging touch a charge rate pad then select a charge time, up to 18 hours. If more than 18 hours of charging time is needed, reset the time when the original time runs out. Refer to the Time Chart in the "Setting the Controls" on page 8 of "Using Your Battery Charger Time Chart."
 9. In the MANUAL mode at the 60-Amp charging rate, the METER will show a charge rate of 25 to 30 amps or less when the battery is at or near full charge. At the 20-Amp charging rate, the METER will show a charge rate of 8 to 10 amps or less when the battery is at or near full charge. At the 2-Amp charging rate, the METER will show a charge rate of .75 to 1 amp when the battery is at or near full charge.
 10. TO AVOID OVERCHARGING in the Manual Mode, monitor the METER frequently.
 11. When the battery is fully charged, turn the POWER switch to the OFF position and unplug the charger power cord from the wall outlet.
 12. Stand away from battery and remove the charger clamps from the NEGATIVE end of the cable first, then from the POSITIVE post.
 13. Clean and store the battery charger in a dry location.

Charging your battery outside the vehicle:

NOTE: A marine (boat) battery must be removed and charged on shore. To charge it on board requires equipment specially designed for marine use.

1. Remove the battery from vehicle, making sure to disconnect grounded terminal first with all accessories and lights turned off in the vehicle.
2. Check the polarity of the battery posts as indicated on the battery case: POSITIVE (POS, P, +) and NEGATIVE (NEG, N, -).
NOTE: On top-post batteries, the positive battery terminal usually has a larger diameter post than the negative one.
3. Connect the red (POSITIVE) charger clamp to the POSITIVE post of the battery. Be sure to rock the clip back and forth to make a solid connection.
4. Attach at least a 6-gauge (AWG) insulated battery cable of at least 24-inches in length to the NEGATIVE battery post. This cable will provide a safer connection because arcing and sparking will occur away from the battery. (The battery cable is not provided with the charger, but may be purchased at most automotive accessory outlets.)
5. Standing as far away from the battery as possible, connect the black (NEGATIVE) lead of the charger to the free end of the cable. Rock the clamp to make a solid connection. **IMPORTANT:** Wear safety glasses and face away from the battery while making this final connection.

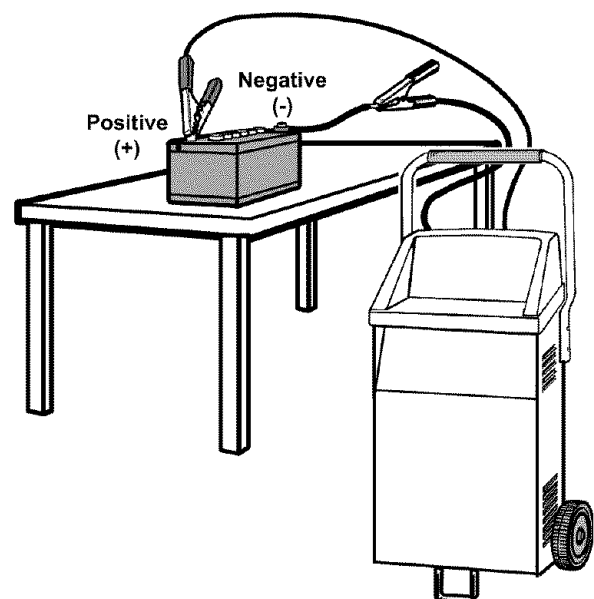

Calculating charge times

The Chart Method

Use the following table to more accurately determine the time it will take to bring a battery to full charge. First, identify where your battery fits into the chart.

- Small batteries — motorcycles, garden tractors, etc. — are usually rated in Ampere Hours (**AH**). For example: 6, 12, 32 AH etc.
- Batteries in cars and smaller trucks are usually rated in Reserve Capacity (**RC**), Cold-Cranking Amps (**CCA**), or both.

- Marine, or deep-cycle batteries are usually rated in Reserve Capacity (**RC**).
- **NR** means that the charger setting is **NOT RECOMMENDED**.

Find your battery's rating on the chart below and note the charge time given for each charger setting. The times given are for batteries with a **50-percent charge** prior to recharging. Add more time for severely discharged batteries.

| BATTERY SIZE/RATING | | | CHARGE RATE/CHARGING TIME - HOURS | | |
|---------------------|----------------------------------|-------------|-----------------------------------|-----------------|--------------|
| | | | 2 AMP | 20 AMP | 60 AMP |
| SMALL BATTERIES | Motorcycle, garden tractor, etc. | 6 - 12 AH | 2 - 4 | NR | NR |
| | | 12 - 32 AH | 4 - 10 | NR | NR |
| CAR/TRUCKS | 200 - 315 CCA | 40 - 60 RC | 11 - 14 | 60 - 90 min. | 20 - 30 min. |
| | 315 - 550 CCA | 60 - 85 RC | 14 - 18 | 90 - 120 min. | 30 - 40 min. |
| | 550 - 1000 CCA | 85 - 190 RC | 18 - 35 | 2 - 3.5 hrs. | 45 - 60 min. |
| MARINE/DEEP CYCLE | | 80 RC | 18 | 105 min. | NR |
| | | 140 RC | 27 | 2 hrs., 45 min. | NR |
| | | 160 RC | 30 | 3.0 hrs. | NR |
| | | 180 RC | 33 | 3.5 hrs. | NR |

The Hydrometer or Electronic Method

To find the time needed to fully charge your battery, determine the battery's charge level with a hydrometer or electronic Percent-of-Charge Tester. The following table will help you convert hydrometer readings to percent of charge values.

| SPECIFIC GRAVITY | PERCENT OF CHARGE | PERCENT OF CHARGE NEEDED |
|------------------|-------------------|--------------------------|
| 1.265 | 100% | 0% |
| 1.225 | 75% | 25% |
| 1.155 | 25% | 75% |
| 1.120 | 0% | 100% |

When you know the percent of charge and the Amp Hour (AH) rating of your battery, you can calculate the approximate time needed to bring your battery to a full charge.

To **convert** Reserve Capacity to Amp Hours, divide Reserve Capacity by 2, and add 16:

$$\text{Amp Hours} = \frac{\text{Reserve Capacity}}{2} + 16$$

NOTE: The Reserve Capacity can be obtained from the battery specification sheet or the owner's manual.

To calculate time needed for a charge:

- Find the percent of charge needed. (A battery at 50 percent charge that will be charged to 100 percent needs another 50 percent (.50)).
- Multiply the Amp Hour rating by the charge needed (.50) and divide by the charger setting (2, 20 or 60 amps).
- Multiply the result by 1.25 and you'll have the time needed, in hours, to bring the battery to full charge.
- Add one additional hour for a deep-cycle battery.

Example:

$$\frac{\text{Amp Hour Rating} \times \% \text{ of charge needed} \times 1.25}{\text{Charger Setting}} = \text{hours of charge}$$

$$\frac{100 \text{ (AH Rating)} \times .50 \text{ (charge needed)} \times 1.25}{20 \text{ (Charger Setting)}} = 3.125 \text{ hours}$$

$$\frac{100 \times .50}{20} = 2.5 \times 1.25 = 3.125$$

You would need to charge your 100-Ampere Hour Battery for a little more than 3 hours at the 20-Amp charge rate using the above example.

Using the engine start feature

Your battery charger can be used to jump-start your car if the battery is low. Follow these instructions when using the ENGINE START feature.

1. Set the POWER switch to the OFF position. Then follow the instructions for connecting the charger to the battery and power source in the section "Charging a battery in the vehicle."
2. Set the BATTERY switch to 6V or 12V to match the battery's voltage.
3. Set the POWER switch to the ON position. The METER display will show MAN (manual mode).
4. Touch RESET, MANUAL and ENGINE START pads in that order. Wait for the display to show RDY. The charger is now ready to have the engine cranked.
5. Crank the engine for **no more than 5 seconds**. If it does not start, wait 3 minutes. (The display will show WAIT during this time and RDY when the time is up.)
6. During extremely cold weather, or if the battery is severely exhausted, charge the battery for about 5 minutes in 60 amp setting before cranking the engine.
7. If the engine still does not start, charge the battery for five more minutes before cranking it again for five seconds.
8. After the engine starts, unplug the charger power cord from the wall outlet. Then move the POWER switch to the OFF position before disconnecting from the battery.

Important:

Do not try to start the engine without a battery in it. You could cause damage to the electrical system.

If the engine does turn over, but never starts up, there is not a problem with the starting system, there is a problem somewhere else with the vehicle.

STOP cranking the engine until the other problem has been diagnosed and corrected.

NOTE: The GFCI outlet should not be used while the Charger is in the Engine Start Mode.

Maintenance and care

A minimal amount of care can keep your battery charger working properly for years.

1. Clean the clamps each time you are finished charging. Wipe off any battery fluid that may have come in contact with the clamps to prevent corrosion.
2. Coil the input and output cords neatly when storing the charger. The cords can be wrapped around the handle of the charger. This will help prevent accidental damage to the cords and charger.
3. Occasional cleaning of the case with a soft cloth will keep the finish shiny and help prevent corrosion.

Troubleshooting

Performance problems often result from little things that you can fix yourself. Please read through this table for a possible solution if a problem occurs.

| PROBLEM | POSSIBLE CAUSE | SOLUTION/REASONS |
|--|--|---|
| No reading on the Display. | Clamps are not making a good connection. | Check for poor connections at battery and frame. Make sure connecting points are clean. |
| No reading on meter. Charger fan not working. or In MANUAL Mode, circuit breaker in charger cycles on and off with a clicking sound. | AC cord and/or extension cord is loose. No power at receptacle. Shorted battery clamps. Shorted battery. Charger leads reversed. Charger set at the START position. | Check power cord and extension cord for loose fitting plug. Check for open fuse or circuit breaker supplying AC outlet. Circuit breaker cycles when current draw is too high. Check for shorted cables and replace if needed. Have a Sears Service Center test the battery. Correct connections. Correct touch-pad settings. |
| Short start cycle when cranking engine. | Drawing more than 275 amps. (12V) Failure to wait for 3 minutes (180 seconds) between cranks. | Crank time varies with the amount of current drawn. If cranking draws more than 275 amps, crank time may be less than 5 seconds. Wait until the METER displays RDY. |
| Meter reads less than selected charge rate when charging a discharged battery. | Extension cord too long. Weak cell or sulfated plate in battery. Battery is only partially discharged. | Use shorter or heavier gauge extension cord. Sulfated battery will eventually take a normal charge if left connected. If the battery will not take a charge, have it tested by a Sears Service Center. Continue to charge battery. |
| Charger makes a loud buzz or hum. | Transformer laminations vibrate (buzz). | Continue charging. Buzz is not abnormal. |
| METER reading stays high. | Battery severely discharged. Wrong battery voltage selected. | Continue charging battery for two more hours. If problem continues, call Sears Service at 1-800-SEARS-64. Make sure BATTERY Voltage Select switch is in proper 6 or 12 volt position. |
| A 120V device plugged into the GFCI outlet will not operate. | The GFCI has "tripped". The charger's AC power or extension cord is loose. Devices exceed 15 amps of the battery charger. | Reset the GFCI outlet by pressing the "RESET" button on the outlet face. See complete test procedure on page 6 for details. Make sure the charger's power cord or extension cord is connected to the AC wall outlet. Check for open (blown) fuse or circuit breaker supplying AC wall outlet. |

**If the above solutions do not eliminate the problem...
call toll-free from anywhere in the U.S.A.**

**1-800-SEARS-64
(1-800-732-7764)**

7 AM to 4:30 PM Central Time Monday through Friday

For information about troubleshooting, call toll-free from anywhere in the
U.S.A. 7 am to 4:30 pm Central Time Monday through Friday.
1-800-SEARS-64 (1-800-732-7764).