

RCA

VideoCassette
Recorder

Owner's Manual

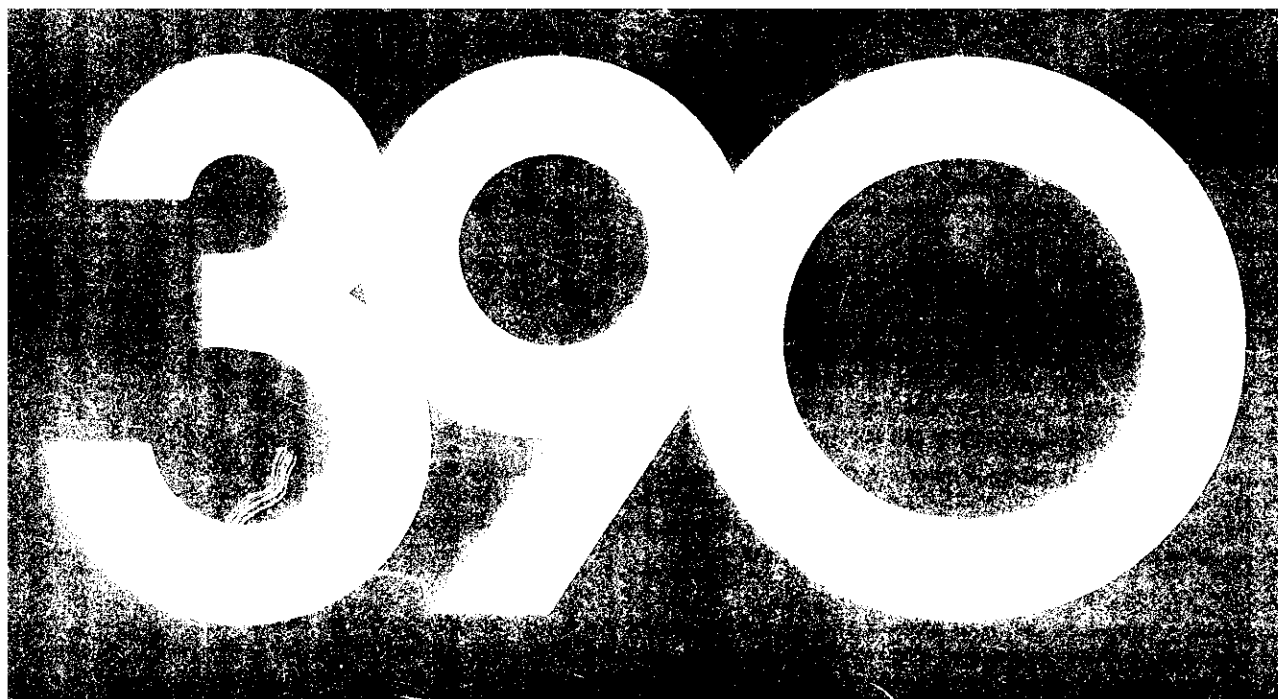

Warranty Registration

No other RCA Video Cassette Recorder has the same serial number as yours. It is important that you record the number and other vital information here, in case your VCR is stolen or in case you need a complete description for any other reason. You will find the model and serial numbers on the back of the VCR. You will also find both numbers recorded on your registration form.

Purchase Date _____

Dealer _____

Model: _____ Serial Number _____

VCR registration is very important so that you can be contacted should there be a safety inspection, modification, or product recall under applicable laws or regulations or otherwise. The dealer who sold you the VCR should have registered it and given you a copy of the registration form.

If your dealer did not give you a copy of the registration, contact him promptly and ask for it. You must be able to show your registration or evidence of purchase date to any RCA Authorized VCR Servicenter or the RCA Service Company to receive warranty parts and service. We suggest you attach your sales slip and warranty registration to this booklet and keep them in a safe place for future reference.

This owner's manual can be used for both VMT390A and VMT390.

Safety Precautions

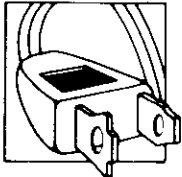



Your VCR operates on 120 volts, 60 Hz (normal household current) and has a polarized plug. Because one blade of the plug is wider than the other, the plug fits in the wall socket only one way. Do not defeat the safety feature of this plug. If you need an extension, use a polarized cord.

Caution: To prevent electric shock do not use the polarized plug on this Video Cassette Recorder with an extension cord, receptacle, or other outlet unless the blades can be fully inserted to prevent blade exposure.

Mise en garde: Pour prévenir les chocs électriques, ne pas utiliser la fiche polarisée de cet appareil avec une rallonge, une prise de courant ou une autre sortie, à moins que les lames ne puissent être insérées à fond sans qu'aucune partie ne soit laissée à découvert.

WARNING: To prevent fire or shock hazard, do not expose this VCR to rain or moisture.

Illustrated below is the label on the back of your Video Cassette Recorder.

| | | |
|---|---|--|
| CAUTION RISK OF ELECTRIC SHOCK DO NOT OPEN |   | MISE EN GARDE RISQUE DE CHOC ELECTRIQUE NE PAS OUVRIR |
|---|---|--|

The symbol of a lightning flash within a triangle is intended to alert the user to the presence of uninsulated "dangerous voltage" within the product's enclosure that may be of sufficient magnitude to constitute a risk of electric shock.

An exclamation point within a triangle is intended to alert the user to the presence of important operating and maintenance (service) instructions in the literature accompanying the product.

Caution: To reduce the risk of electric shock, do not remove the cover or back. No user-serviceable parts are inside. If you spill liquid on the VCR disconnect the power cord to prevent possible fire or shock hazard and consult authorized service personnel. Moisture can damage internal parts. Refer all service to RCA Authorized Servicenter personnel or the RCA Service Company only.

Caution: Maintain electrical safety. Powerline-operated equipment or accessories connected to this unit should bear the UL listing mark or CSA certification mark on the accessory itself and should not have been modified so as to defeat the safety features. This will help avoid any potential hazard from electric shock or fire. If in doubt, contact qualified service personnel.

Note to Cable TV Installer:

This reminder is provided to call your attention to Article 820-22 of the National Electric Code, that provides guidelines for proper grounding and, in particular, specifies that the cable ground shall be connected to the grounding system of the building as close to the point of cable entry as practical.

Caution: The unauthorized recording of television programs and other materials may infringe the rights of others.

Using This Manual

Congratulations on your choice of an RCA VCR. You have selected a high-quality, precision-engineered instrument designed to give you years of trouble-free video and audio enjoyment.

To get best performance from your new VCR, it is important that you carefully read and follow the operating instructions in this manual in the sequence in which they are presented.

Should you experience a problem, please follow the "Things to Check" near the end of this manual. The warranty on the back cover describes what RCA will do for you should your new VCR need service during the warranty period. It also tells you how and from whom you should request service.

Contents

| | |
|--|--------------------|
| Warranty Registration | Inside Front Cover |
| Safety Precautions | Inside Front Cover |
| Installation | |
| • Unpacking, Choosing Location | 2 |
| • General Installation Information | 2 |
| • Antenna Connections | 3-4 |
| • Cable-TV Connections | 5-6 |
| • TV Monitor/Receiver Connections | 7 |
| What Your VCR Will Do | 8 |
| Video Cassettes | 9 |
| Basic Operation | |
| • Basic Operating Controls and Displays | 10 |
| • Inserting and Removing Cassettes | 10 |
| • Turning on Your VCR for the First Time | 11 |
| • Programming Active Channels into Tuner | 11 |
| • Deleting Channels from the Scan List | 11 |
| • Adding Channels to the Scan List | 11 |
| • Setting Your TV to the VCR Channel | 12 |
| • Setting the VCR/TV Switch | 12 |
| • Simplified Installation Checklist | 12 |
| Remote Control | |
| • Battery Installation | 13 |
| Setting the Clock | 14 |
| First Recording and Playback | 15 |
| Operating Controls (Detailed) | 16 |
| Special Effects and Features | |
| • Pause During Recording | 17 |
| • Pause for Stop-Action Playback | 17 |
| • Frame Advance | 17 |
| • Slow Motion | 17 |
| • Picture Search | 17 |
| • Tape Counter | 17 |
| • Memory Stop | 17 |
| • Tracking Control | 17 |
| Quick-Reference Operating Guides | |
| • Normal TV Viewing | 18 |
| • Recording With TV Off | 18 |
| • Recording and Viewing the Same Program | 18 |
| • Recording and Viewing Different Programs | 19 |
| • Basic Playback | 19 |
| • Recording from Another VCR | 20 |
| • Camera Recording | 21 |
| Express Recording | 22 |
| Programming the Timer | 23-24 |
| Timer Recording | 25 |
| Alternate Remote Control Units | 26 |
| Optional Accessories | 27 |
| Cabinet Cleaning | 28 |
| Things To Check Before You Call for Service | 28 |
| Index (Alphabetical) | 29 |
| Specifications | Back Cover |
| Warranty | Back Cover |



Installation

Unpacking

When you unpack your new VCR, be sure you have removed all the accessories and information sheets. We recommend that you save the packing materials and box in case you ever need to ship or store your VCR.

The accessories supplied for connecting your antenna, VCR, and TV set are shown here. The remote control unit and its batteries are also packed in with the VCR.

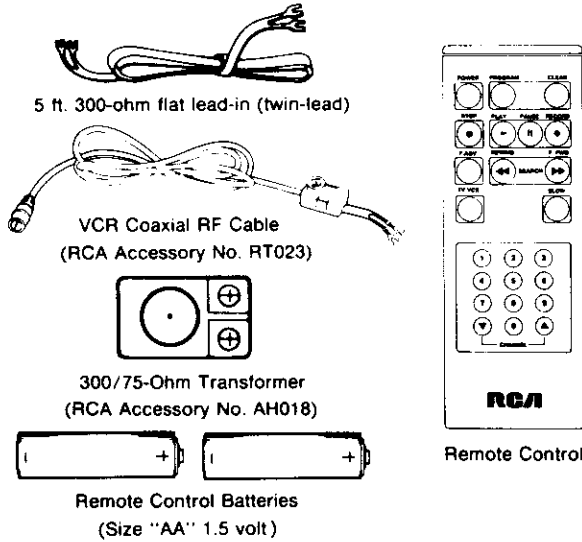

Location

- Choose a location that is convenient, but away from sources of heat such as direct sunlight and heating units.
- If the VCR is to be installed in an equipment rack or cabinet with other devices, be sure that there is adequate ventilation at the back and around the sides of the components. The VCR should not be placed on or directly above a stereo amplifier because of the heat that rises from the amplifier.
- Choose a flat surface at least as large as the VCR so that it rests on its mounting feet. It is important that air can pass through the ventilation holes in the bottom of the unit to prevent it from overheating. Do not operate the VCR on a rug or carpet because the pile will obstruct these holes.

Some TV sets may cause interference in home VCR's. To avoid interference and get the best performance from your VCR, follow these guidelines:

- When placing the VCR under a TV, keep at least 18 inches between the bottom of the TV and the top of the VCR.
- If interference is present when the VCR is used on top of the TV or at the 18-inch distance below the set, move the VCR to a position beside the TV.
- If interference continues after all the above, call your dealer or service representative.

General Installation Information

IMPORTANT

There are two basic steps for connecting your new VCR to your present TV and antenna(s) or cable-TV. The first step is to disconnect the antenna(s) or cable-TV from the TV and reconnect it to the VCR. The second step is to connect the VCR to the TV. Be sure you do both steps.

Since there are many different types of antennas and TV's, there are several ways to make the above connections. Therefore, the instructions have been divided into two sets, one set for connections to your own antenna(s) on pages 3 and 4, and another set for connections to a cable-TV system on pages 5 and 6. If you have a TV monitor/receiver, you may want to make the additional connections described on page 7.

The antenna is the "signal receiver" that picks up TV broadcasts. Some modern antennas receive both VHF (Very High Frequency) channels 2 through 13, and UHF (Ultra High Frequency) channels 14 through 83. Some antennas are designed only for VHF reception and others are designed only for UHF reception.

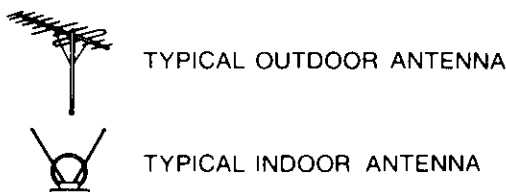

Signals from your antenna are conducted through flat "twin-lead" cable, or through round "coaxial" cable.

TYPES OF ANTENNA CABLES

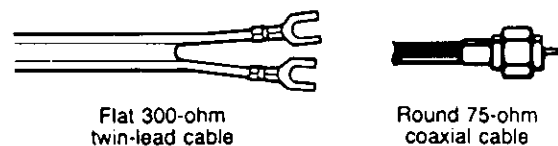

Cable-TV (CATV) supplies television signals directly by round cable without the need for a home antenna. Cable-TV delivers both VHF and UHF channels and programs not available from a home antenna. Although Cable-TV systems vary, most require use of a converter box for TV's that are not Cable-TV compatible.

In most situations you will get better picture quality if you use an outdoor antenna or connect your TV and VCR to a cable-TV system. If this is not possible, use a good quality indoor antenna. Your indoor antenna should have separate leads for VHF and UHF if you are in an area with both VHF and UHF stations — or you may use separate VHF and UHF indoor antennas.

Because you usually must reposition an indoor antenna when you change channels, it seldom is convenient to use the same indoor antenna for both TV viewing and VCR recording, especially if you wish to view one channel while recording another. For this reason, it is recommended that, if you must use an indoor antenna, buy two and use one for your TV and one for your VCR.

Antenna Connections

1. Disconnect Existing Antenna from TV and Connect it to VCR.

(Your antenna will probably resemble one of the diagrams on this page.)

A. If your existing antenna is connected to your TV like this:

Disconnect the antenna from your TV and connect it to your VCR like this:

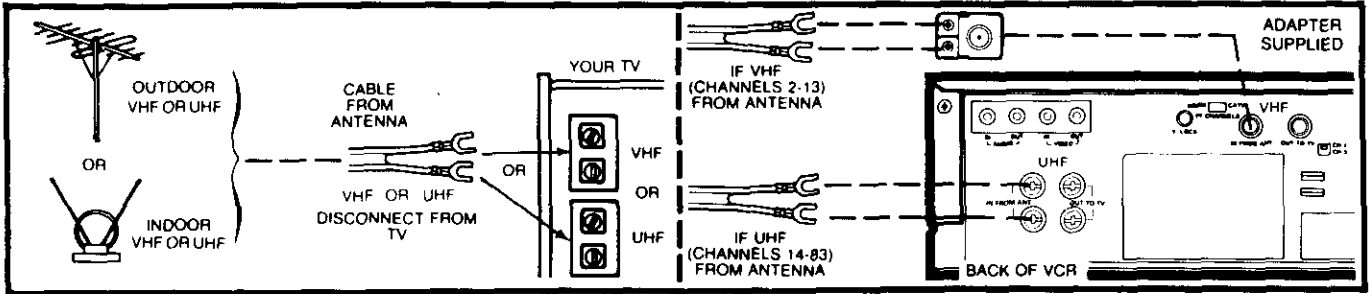

B. If your existing antenna is connected to your TV like this:

Disconnect the antenna from your TV and connect it to your VCR like this:

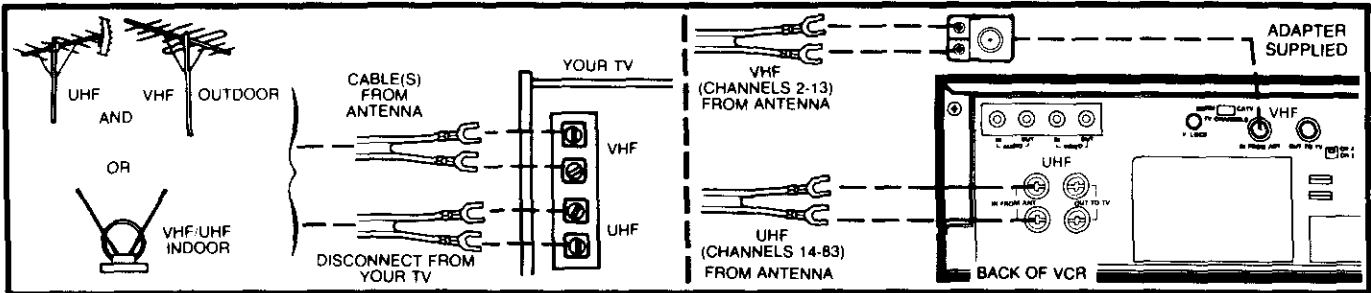

C. If your existing antenna is connected to your TV like this:

Disconnect the antenna from your TV and connect it to your VCR like this:

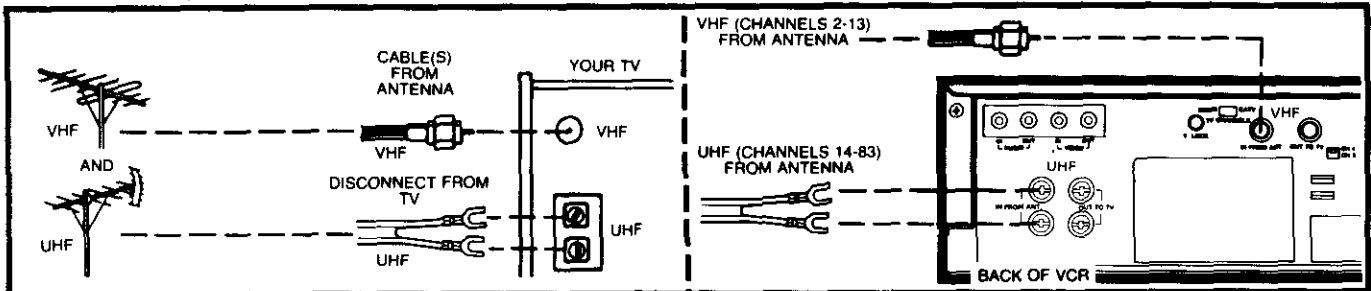

D. If your existing antenna is connected to your TV like this:

Disconnect the antenna from your TV and connect it to your VCR like this:

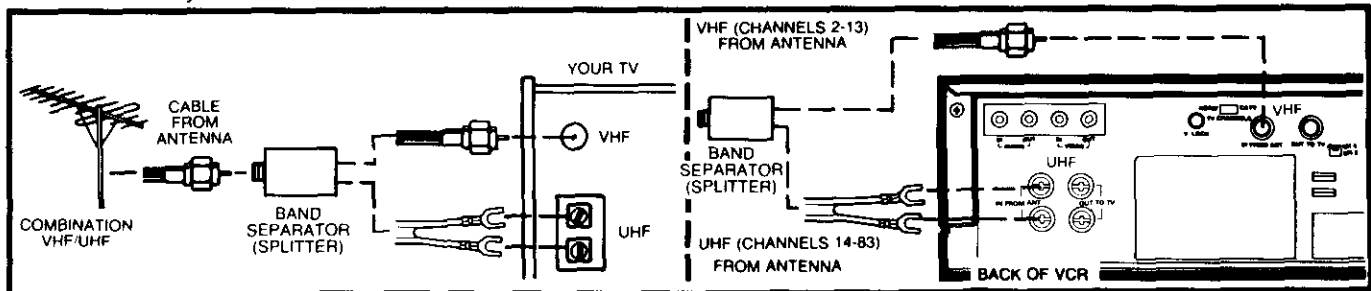

(Continued on next page)

Antenna Connections (continued)

2. Connect VCR to back of TV. (The back of your TV will probably resemble one of the diagrams below.)

A. If the antenna connection on the back of your TV looks like this:

Connect the VCR to your TV like this:

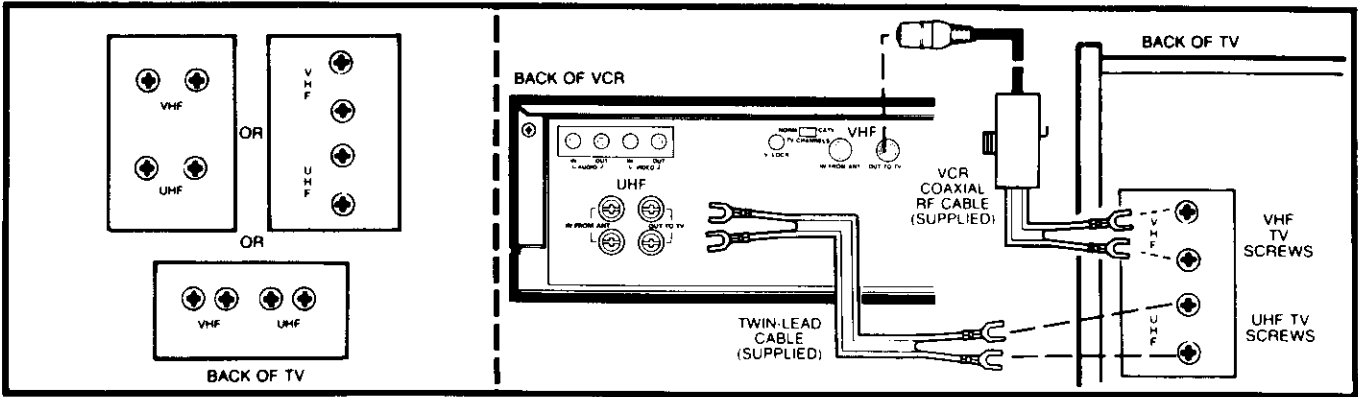

B. If the antenna connection on the back of your TV looks like this:

Connect the VCR to your TV like this:

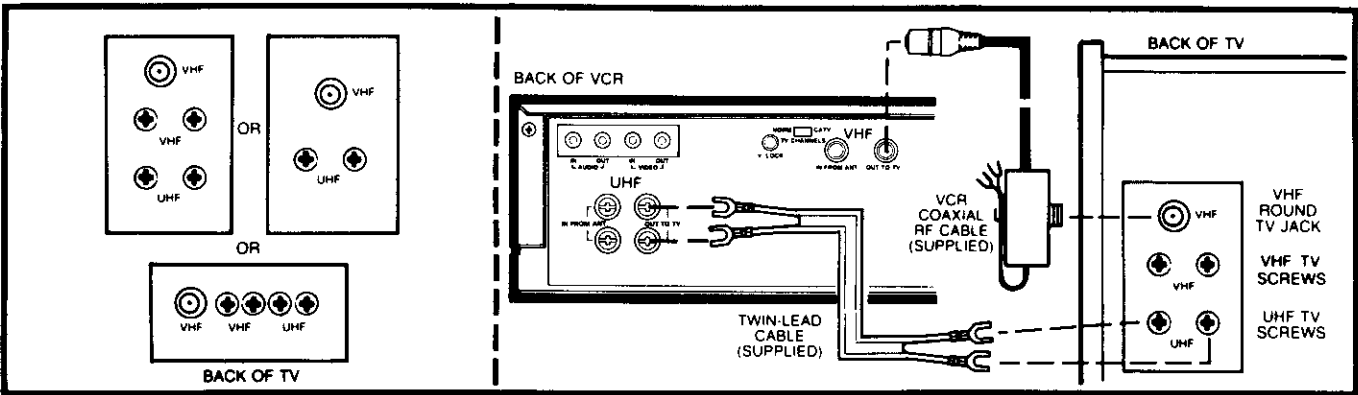

C. If the antenna connection on the back of your TV looks like this:

Connect the VCR to your TV like this:

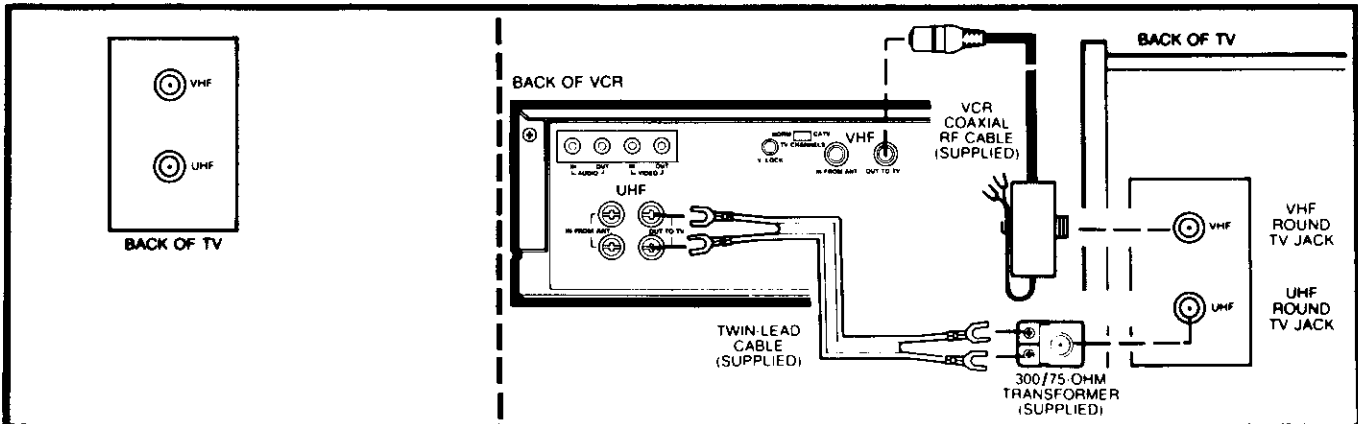

Cable-TV Connections

Your VCR is designed to receive **unscrambled** cable channels 2 through 48 plus 98 and 99 without a "converter box." (These channels are sometimes designated 2 through 13, A through W, W+1 through W+12, and A-2 and A-1.) There are several ways to hook up your VCR and TV, depending on the type of TV you have, the cable channels you receive, and whether or not some of the cable channels must be "unscrambled." One of the five methods shown on this page and the next will likely fit your requirements. You may want to change from one hookup to another, depending on what you want to do with your VCR.

| IF YOUR TV IS: | AND YOUR CABLE-TV SYSTEM HAS: | THEN USE DIAGRAM(S): |
|----------------------|--------------------------------|----------------------|
| cable-compatible | no scrambled channels | A |
| | some or all channels scrambled | D |
| not cable-compatible | no scrambled channels | B or C |
| | some or all channels scrambled | D |

Note: If you wish to also record one or more local UHF channels that your Cable-TV system does not offer, first follow the appropriate cable-TV connection instructions described below, then connect your UHF antenna to your VCR as described in the section titled "Antenna Connections".

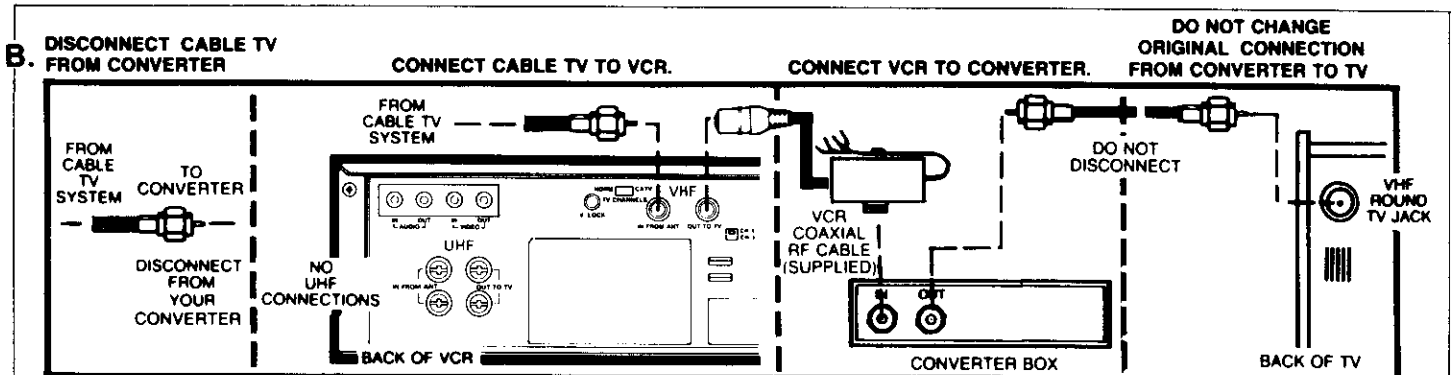
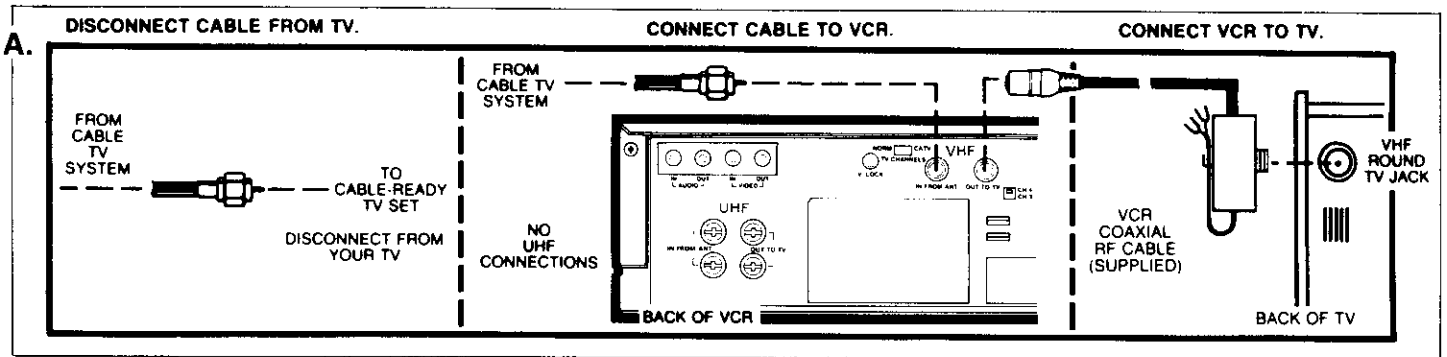

When you use this set of connections, keep your TV tuned to the channel you have been using (usually channel 3 or 4) and use the converter box as you always have for normal TV viewing and for viewing some other channel while you are recording.

When you want to view the channel you are recording, or when you play the VCR, tune the "converter box" to the same channel that you have set the channel switch on the back of the VCR, either channel 3 or 4. (This is called the "VCR channel" throughout the operating instructions in this manual.)

(Continued on next page)

Cable-TV Connections (Continued)

C.

When you use these connections the A-B switch is used to select either the converter output or the VCR output.

This arrangement will let you use your VCR as a "remote-controlled converter box" when you are not recording.

- | | | |
|--|------------------------------------|------------------------------|
| 1 Disconnect Cable-TV from converter. | 4 Connect splitter to converter. | 7 Connect VCR to A-B switch. |
| 2 Disconnect TV from converter cable. | 5 Connect splitter to VCR. | 8 Connect A-B switch to TV. |
| 3 Connect Cable-TV to input of splitter. | 6 Connect converter to A-B switch. | |

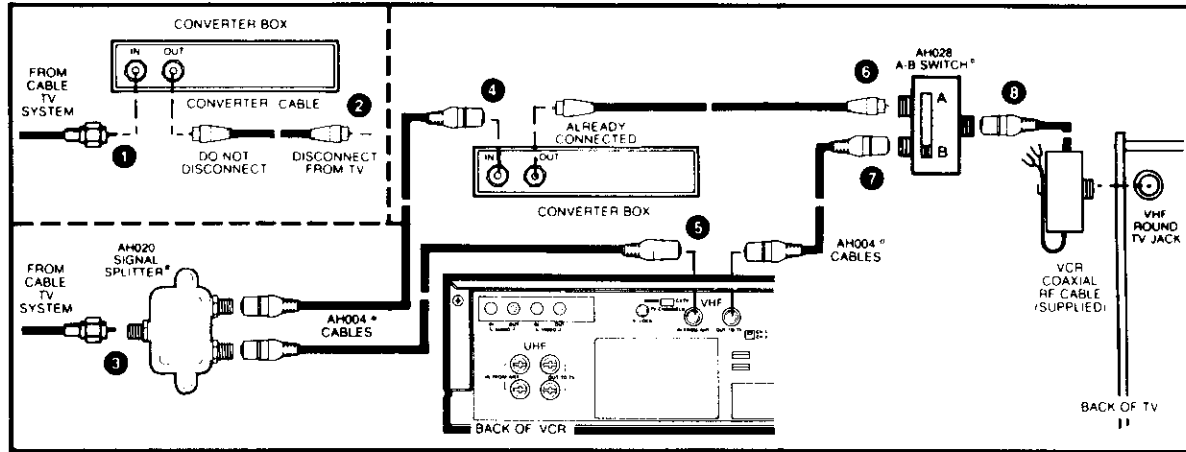

* Optional accessory available from your RCA Dealer.

Use "A" Position of A-B Switch For:

- Viewing any cable-TV channel while you record some other channel with the VCR.
- Viewing all scrambled channels.
- Viewing cable channels when the VCR is turned off. (Cable channels 2 through 13 can also be viewed with the VCR turned off and the A-B switch set to position "B.")

Use "B" Position of A-B Switch For:

- Playing a recording.
- Viewing a nonscrambled channel at the same time you are recording it (channel selected with the VCR tuner).

D.

This system requires two "converter boxes" from your cable-TV company, and there may be an additional

charge. All channels must be selected with the converter boxes, both for recording and normal TV viewing.

- | | | |
|--|---|------------------------------|
| 1 Disconnect Cable-TV from converter. | 4 Connect splitter to each of the converters. | 7 Connect VCR to A-B switch. |
| 2 Disconnect TV from converter cable. | 5 Connect one converter to A-B switch. | 8 Connect A-B switch to TV. |
| 3 Connect Cable-TV to input of splitter. | 6 Connect other converter to VCR. | |

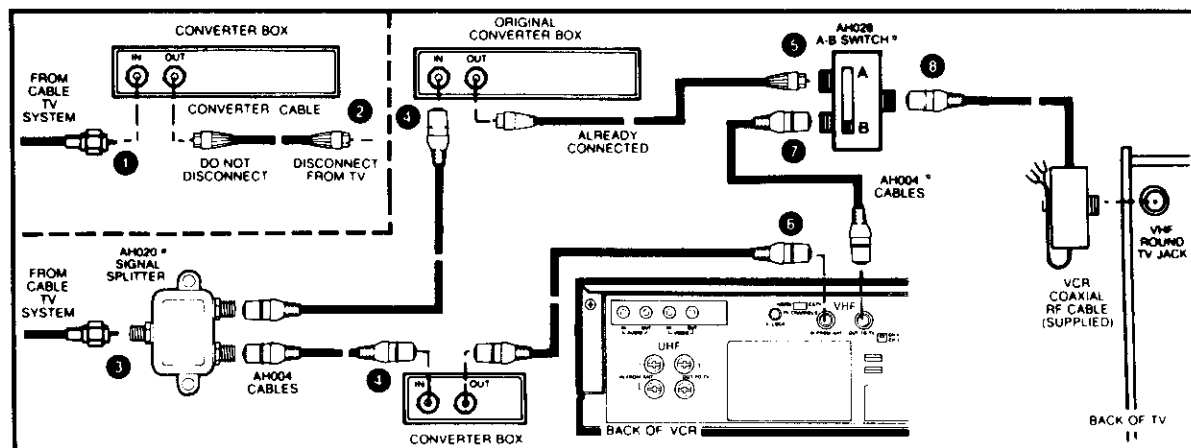

* Optional accessory available from your RCA Dealer.

Use "A" Position of A-B Switch For:

- Viewing any cable-TV channel while you record some other channel with the VCR.
- Viewing any cable-TV channel when your VCR is turned off.

Use "B" Position of A-B Switch For:

- Playing a recording.
- Viewing any channel at the same time you are recording it. Select the channel with the converter that is connected to the VCR, and tune the VCR to the output channel of the converter (usually 3 or 4).

Note: When you set the A-B switch to "B," tune your TV to the same channel that you have selected on the back of your VCR (3 or 4). This is called the "VCR channel" throughout this manual.

What Your VCR Will Do

Recording Sources

The built-in VHF/UHF/Cable-compatible tuner can tune in any of the standard broadcast channels and up to 49 Cable-TV channels. Since your VCR has its own tuner, you can use it to record one program while you watch another one selected with your TV tuner. Also you can view and record the same program if you prefer. Your VCR also has special video and audio input connectors for recording from a camera or another VCR.

Automatic Tuner Programming

Available channels can be automatically preset into the tuner for selection with the *CHANNEL-UP* and *CHANNEL-DOWN* buttons. "Automatic Programming" searches through the channel numbers for broadcast or cable-TV reception, finds the channels that are available from your antenna or cable-TV system, and permanently stores them in the tuner's memory. Afterwards, you can select any of these channels with the *CHANNEL Up* and *Down* buttons on the VCR or the remote control, simply by pressing the button until the channel number appears in the display. If you prefer, you can select a channel number directly with the numbered buttons on the remote control.

Recording Speeds and Times

You can choose any one of the three standard speeds when you make a recording. The recording times for various cassettes and the reason for using each recording speed are explained on page 9.

Unattended Recording with Remote Programming/On-Screen Display

The VCR timer can be preset up to one year in advance to record up to four different programs. You can record the same program every week day or on the same day of every week until you cancel the program. The VCR will turn on automatically at the time you have selected, record your program, and turn off automatically.

All programming is done using the infrared remote control. Programming instructions are displayed on your TV screen, leading you step-by-step through the programming sequence.

Express Recording (XPR)

XPR lets you record for up to four hours without programming the timer. Simply select the channel and the starting time (immediately or up to 24 hours delayed start) and select the length of time you wish to record. The rest is automatic.

Conventional Playback

Your VCR uses the standard **VHS** recording system so that pre-recorded VHS tapes and tapes recorded on another VHS-type VCR can also be played. Your VCR will play VHS cassettes recorded at any of the three standard speeds. It automatically selects the same speed for playback that was used for recording the cassette. By using the electronic tape counter and the *FAST-FORWARD* and

REWIND controls, you can "cue" to any starting point on the tape before you begin playback.

Picture Search

The *FAST-FORWARD* and *REWIND* buttons can be used for "Picture Search" when you play a tape. When you press one of these buttons the playing speed is increased so that you can quickly locate the picture you want to view. Normal playing speed resumes and sound is restored when you release the button. A picture is displayed when you search a tape recorded at any speed, but quality is best for tapes recorded at SLP.

Pause - Stop Action - Frame Advance

Pressing the *PAUSE* button stops the tape's forward motion for "stop-action" viewing during playback, or to eliminate unwanted material when you are recording. After you have stopped the action during playback, the *FRAME ADVANCE* button on the remote control lets you advance the tape one frame at a time so that you can see all the motion details. Stop-action and frame advance are designed for use at the SLP speed. They may be used on tapes recorded at other speeds, but the picture quality will not be as good as that at SLP.

Slow Motion

Press *SLOW* on the remote unit or press *PLAY* during play/pause to change from normal playing speed to slow motion. The *PLAY* button will restore normal playing speed. Slow Motion is designed for use at the SLP speed. It may be used on tapes recorded at other speeds, but the picture quality will not be as good as that at SLP.

Memory Stop

When the tape counter is displayed instead of time, fast-forward and rewind will stop when the counter reads 0000. By resetting the counter to 0000 at the desired point on the tape, you can stop at this point for repeated viewing of a certain scene.

Automatic Rewind

Your VCR automatically rewinds and then stops when it comes to the end of the tape. To avoid accidental erasure during Unattended Recording and Express Recording, the VCR stops at the end of the tape but does not rewind.

Power Off from Rewind

You can turn off the power during rewind, and the VCR will finish rewinding and turn off automatically.

Infrared Remote Control

The remote hand unit may be used instead of the front-panel buttons to control the major functions of the VCR. The remote control has additional buttons for selecting any tuner channel by number, setting the clock, programming the timer, and operating Slow Motion and Frame Advance.

VHS HQ Picture Quality

This VCR incorporates VHS HQ (High Quality) circuitry for improved picture quality. It is fully compatible with earlier VHS VCRs.

TV Monitor/Receiver Connections

Direct Video and Audio Connections

Connecting the video output and audio output jacks of your VCR to the corresponding video and audio input jacks of your TV monitor/receiver may produce a slightly better picture during playback. These "direct" signal connections bypass the TV tuner during playback, thus reducing the probability of "noise" and other "extra" signals that may degrade picture quality.

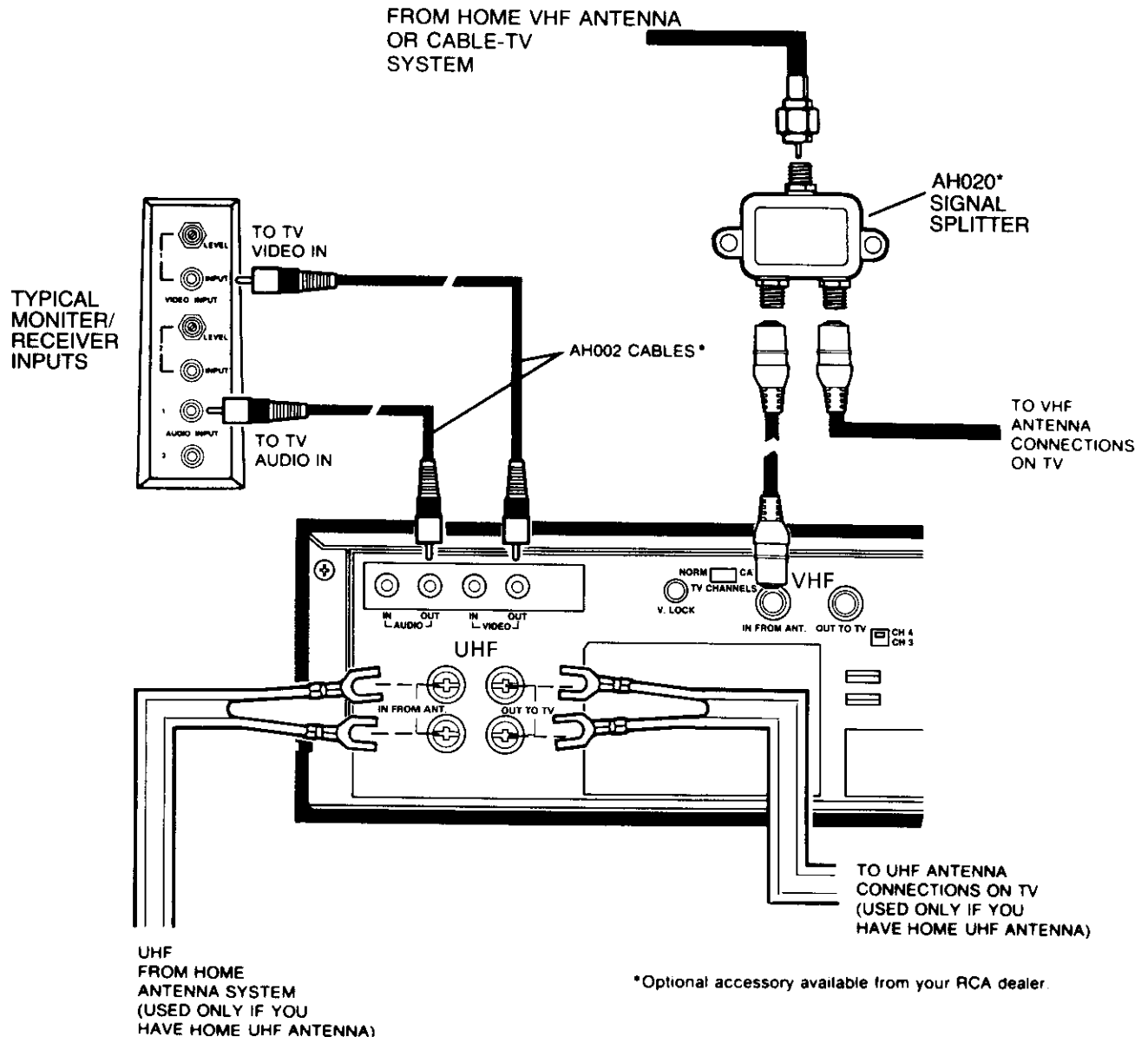

Operating Instructions:

- For normal VHF or cable-TV viewing independent of VCR, place TV Monitor/Receiver in **TUNER** operational mode and select channels with TV Monitor/Receiver tuner.
- For viewing of channel being recorded, place TV Monitor/Receiver in **VIDEO INPUT** operational mode. Use VCR tuner to select channel.
- For recording one channel while viewing another, place TV Monitor/Receiver in **TUNER** operational mode. Use VCR tuner to select channel to be recorded. Use TV Monitor/Receiver tuner to select channel to be viewed.
- For playback of recorded program, place TV Monitor/Receiver in **VIDEO INPUT** operational mode.

Video Cassettes

RCA recommends that RCA cassettes be used with this unit. The tape in RCA cassettes is of high-quality formulation, intended for use with multi-speed VHS video cassette recorders. It has been manufactured to RCA's critical specifications for excellent performance with RCA VCR's. Use of tape not meeting these specifications could considerably reduce the performance of your VCR.

Use of poor quality tapes or tapes that have been damaged or mishandled can contaminate the VCR heads. This can cause a snowy picture or a missing picture during playback. Because RCA has no control over the type of tape purchased or rented by consumers, **head cleaning is not covered by RCA's warranty.** It is considered normal maintenance.

Playing a new RCA tape for approximately 30 minutes often will clean the VCR heads and improve your picture. If a snowy picture or missing picture condition persists, consider the use of a chemical non-abrasive head cleaning tape (RCA Stock No. AV009). It is available from your dealer and many electronic supply stores.

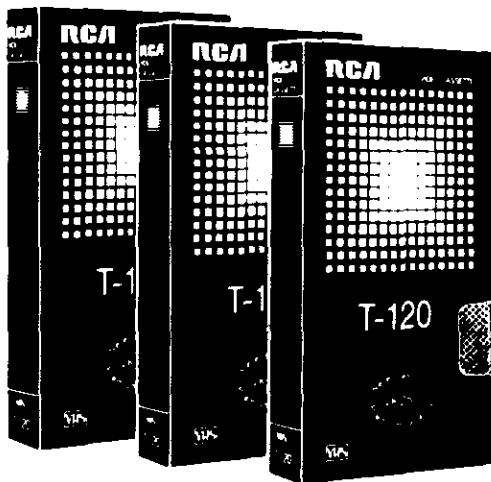

Erase Protection

To prevent erasing a recording you want to keep, remove the safety tab from the back of the cassette as shown in the illustration. Recording is impossible when this tab is removed. To record again on a cassette that has the tab removed, simply cover the hole with vinyl tape.

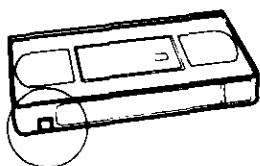

Safety tab

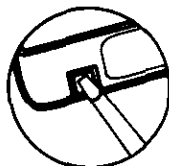

To prevent erasure, break off the tab.

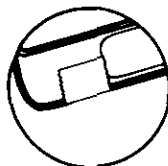

To record again, cover the hole with vinyl tape.

Cassette Playing Times and Speeds

The playing times and counter readings below are approximate. Also, it is assumed the counter is set to 0000 at the start of the tape.

| SPEED | T-60 CASSETTE (VK125) | | |
|---------|-----------------------|--------------------|---------------------|
| | SP Counter Reading | LP Counter Reading | SLP Counter Reading |
| Time | | | |
| 1 hour | 2080 (end) | 1120 | 760 |
| 2 hours | | 2080 (end) | 1460 |
| 3 hours | | | 2080 (end) |

| SPEED | T-120 CASSETTE (VK250) | | |
|---------|------------------------|--------------------|---------------------|
| | SP Counter Reading | LP Counter Reading | SLP Counter Reading |
| Time | | | |
| 1 hour | 3520 | 2100 | 1520 |
| 2 hours | 5680 (end) | 3520 | 2600 |
| 3 hours | | 4660 | 3520 |
| 4 hours | | 5680 (end) | 4300 |
| 5 hours | | | 5000 |
| 6 hours | | | 5680 (end) |

| SPEED | T-160 CASSETTE (VK330) | | |
|---------|------------------------|--------------------|---------------------|
| | SP Counter Reading | LP Counter Reading | SLP Counter Reading |
| Time | | | |
| 1 hour | 3740 | 2160 | 1560 |
| 2 hours | 6120 | 3740 | 2740 |
| 3 hours | | 5020 | 3740 |
| 4 hours | | 6120 | 4640 |
| 5 hours | | | 5400 |
| 6 hours | | | 6120 |
| 7 hours | | | 6760 |
| 8 hours | | | 7420 (end) |

Recording Speed

This information will help you decide which tape speed to use when recording.

- **SP:** Standard Play uses the most tape. Video recorded at this speed has the least "picture noise" (snow) in normal playback. Pre-recorded tapes use SP for this reason and also because all VHS recorders have this speed.
- **LP:** Long Play uses one-half as much tape as SP. This speed is provided primarily for playing tapes recorded on older machines that do not have SLP.
- **SLP:** Super Long Play uses one-third as much tape as SP. SLP has slightly more "picture noise" than LP in normal playback (which may not be noticeable). **Your VCR's special effects (search, stop action, slow motion, and frame advance) are designed for optimum performance at the SLP speed.**

Cassette Care and Storage

Follow these directions for continued high-quality performance from your cassettes.

- When you are finished with a cassette, rewind it and remove it from the VCR.
- Never attempt to force open the cassette door.
- Store cassettes vertically in their protective boxes at normal room temperatures. Avoid extreme heat and humidity. Extreme heat can warp the cassette or cause the tape to stretch excessively.
- Be especially careful to keep dust from entering the cassette and the VCR mechanism. All dust is abrasive and it will cause excessive wear of both the tape and the VCR's recording/playback heads.

Basic Operation

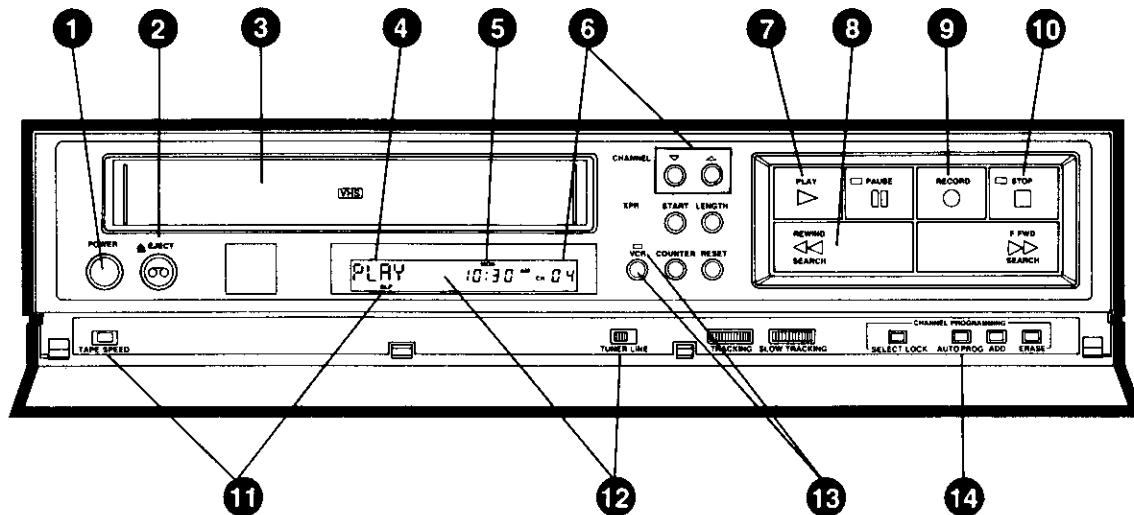

Basic Operating Controls and Displays

Now that you have connected your VCR to your TV and antenna or cable-TV system, you are ready to turn it on. You don't need to know all the details about the controls and display before you begin using your new VCR, so only those you will be using immediately are discussed here. (Additional information about the controls is on pages 16-17.)

- 1 **POWER:** Turns the VCR on and off.
- 2 **EJECT:** Ejects the cassette from the VCR. The light in the *EJECT* button is on when a cassette is in place.
- 3 **Cassette Compartment:** Push the cassette through the door to load it.
- 4 **Status Display:** Tells what the VCR is doing: *PLAY* for playback, Search or Slow Motion; *REC* for record; *REW* for rewind; *FF* for fast forward; blinking *PLAY* for Play/Pause or Frame Advance; blinking *REC* for Record/Pause. This area is blank at other times.
- 5 **Time Display:** The time and day of the week are normally shown here. If the clock has stopped you will see "--:--" in this area.
- 6 **CHANNEL selector buttons and display:** ▼ selects the next lower channel and ▲ selects the next higher channel. The channel number appears in the display unit.

- 7 **PLAY:** Starts playback.
- 8 **REWIND:** Rewinds the tape when the VCR is stopped.
- 9 **RECORD:** Press *RECORD* and *PLAY* at the same time to begin recording.
- 10 **STOP:** Stops whatever the VCR is doing (record, playback, rewind, or fast forward).
- 11 **TAPE SPEED and Indicators:** Press the button to change recording speed. The lighted indicator tells the tape speed. (Use "SLP" for normal recording.)
- 12 **TUNER/LINE:** Be sure it is set to *TUNER* for recording TV programs. *LINE* is for recording from a camera or another VCR. The *LINE* light is off when the switch is set to *TUNER*.
- 13 **VCR:** Selects the signal source that is fed to the VHF antenna connection on your TV. When the light above the button is off, your TV receives signals from your VHF antenna or from the Cable-TV system. When the light is on, signals come from the VCR tuner or the tape that is playing. (This switch is called the "VCR/TV switch" in this manual to avoid confusion with the VCR itself.)
- 14 **CHANNEL PROGRAMMING:** Explained on page 11.

Inserting and Removing Cassettes

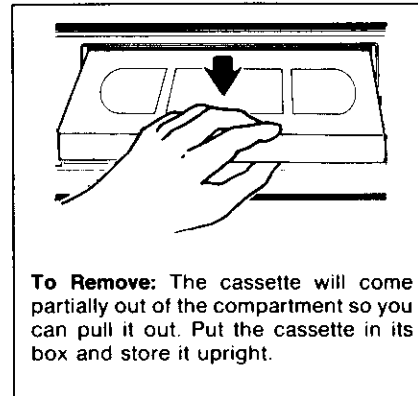
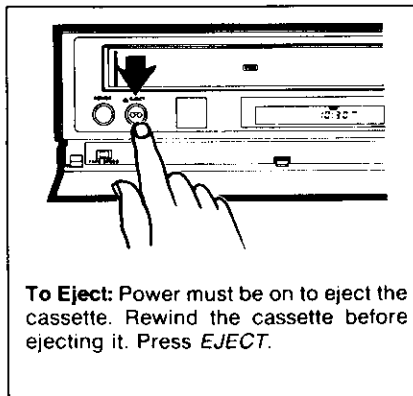
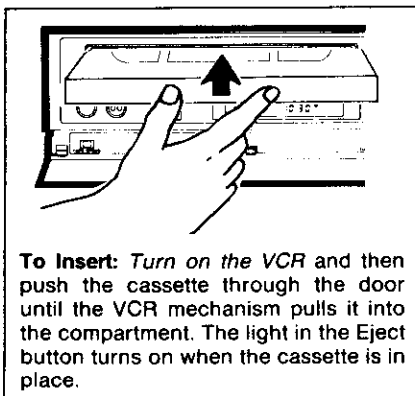

Basic Operation (continued)

Turning on Your VCR for the First Time

When you have finished connecting the cables to your antenna and TV, plug in the VCR's power cord and press **POWER**. The light in the **STOP** button should come on. If it flashes, too much moisture has collected inside the unit for it to operate. Leave the VCR turned on until the internal heat dries it and the light stops flashing. Proceed below when the light in the **STOP** button is on and not flashing.

Programming Active Channels into VCR's Tuner

The **AUTO PROG** (Automatic Programming) button makes it easy and convenient to program TV stations into the VCR's scan list. The scan list is the list of channels that your VCR tuner stops on when you press the **CHANNEL UP** or **CHANNEL DOWN** button. The scan list is empty, however, until you program active channels as described below.

Automatic programming is usually a "one-time" procedure, but you will need to repeat it if you move to a location that has different channels, or if power is interrupted for an extended period.

To program active channels:

1. Turn on VCR by pressing **POWER** button.
2. Set the **NORM/CATV** switch on the back of the VCR to the **NORM** position if your VCR is connected to a home antenna system. Set the switch to the **CATV** position if your VCR is connected to a cable-TV system.

Note: Your VCR was shipped from the factory with this switch set to **NORM**.



3. Press and release the **SELECT LOCK** button. (The channel number will be flashing.)
4. Press and release the **AUTO PROG** button.
 - The tuner will automatically cycle through all available channels in the area and place them in the scan list. This takes about a minute. The channel numbers will stop changing when the tuner is finished cycling.
5. Press **SELECT LOCK**. (The channel number will stop flashing.) Programming is now complete and you can use the **CHANNEL ▲/▼** buttons to select channels.
6. If you want to delete or add individual channels from the scan list, refer to the instructions at the right.

Deleting Channels from the Scan List

You may want to have only a few favorite channels in the scan list so you can select them more quickly with the **CHANNEL ▲** and **▼** buttons. (Use the numbered buttons on the remote control to select channels you deleted from the scan list.) Occasionally Automatic Programming may include a vacant channel in the scan list if there happened to be some sort of "noise" or "stray signal" on the channel when the tuner was programmed. This procedure explains how to delete any unwanted channels from the scan list.

1. Use the **CHANNEL ▲** or **▼** button to select the channel that you want to remove from the scan list.
2. Press **SELECT LOCK**. The channel number will begin flashing.
3. Press **ERASE**. The sound will go off, which tells you that the channel number has been deleted from the scan list.
4. Press **SELECT LOCK** again to return the tuner to normal operation. The tuner will immediately skip to the next channel in the scan list and the number will not flash.
5. Repeat the procedure for each channel you want to delete from the scan list.

Notes:

- Channel numbers flash when the **SELECT/LOCK** switch is in **SELECT**, and the **CHANNEL ▲/▼** buttons will select every channel, whether or not it is in the scan list.
- Channel numbers do not flash when the **SELECT/LOCK** switch is in **LOCK**, and the **CHANNEL ▲/▼** buttons will select only those channels that are in the scan list.

Adding Channels to the Scan List

You may have deleted a channel from the scan list and want to put it back. Occasionally Automatic Programming may "miss" an active channel because the signal is very weak or because the channel happened to be "off the air" when the tuner was programmed. Use this procedure to put any channel in the scan list.

1. Press **SELECT LOCK**.
2. Use the **CHANNEL** or digit (0-9) buttons on the hand unit to select the channel you want to add to the scan list. There will be picture but no sound at this time, and the channel number will flash.
3. Press **ADD**. The sound will come on to tell you the channel has been added to the scan list.
4. Press **SELECT LOCK**. The channel number will stop flashing to tell you the tuner is in its normal operating mode.

Basic Operation (continued)

Setting Your TV to the VCR Channel

The "VCR Channel" is the TV channel you use for viewing what the VCR is recording or playing, and for viewing the signal from the VCR tuner when it is stopped. Your TV must be set to this channel, and the light above the *VCR/TV* switch on your VCR must be on.

Selecting the VCR channel is normally a one-time procedure, since there is little reason ever to change it. Proceed as follows:

1. Be sure the *TUNER/LINE* Switch behind the auxiliary control door is set to *TUNER*.
2. Decide whether you want to view your VCR on Channel 3 or Channel 4 of the TV. If one of these channels is vacant in your area, you should use it. Otherwise, pick the channel you view less.
3. Set the channel switch on the back of the VCR to whichever channel you have chosen, and then turn on your TV and tune it to the same channel. This is the "VCR channel."

Setting the VCR/TV Switch

1. Push the *VCR/TV* switch so that the indicator light above the switch is on. When the light is on, the VCR is in the "VCR mode" and your TV must be tuned to the VCR Channel (channel 3 or 4). Your TV will then display whatever tape the VCR is playing or whatever channel the VCR is tuned to.
2. Push the *VCR/TV* switch again so that the indicator light above the switch is out. When the light is out, the VCR is in the "TV mode" and your TV will work like it always did before you connected the VCR.

The *VCR/TV* switch allows you to record one program with the VCR while you watch another program on your TV. To do this, first put the VCR in the "VCR mode" (light on) and start recording the program. Then press the *VCR/TV* switch to the "TV mode" (light out) and tune your TV to the other channel you want to watch.

Simplified Installation Checklist

This simplified checklist will help you quickly determine if you have completed all the basic installation steps.

- [] Make sure your VCR is connected properly as explained on pages 2-7.
- [] Press *POWER* to turn on VCR.
- [] Set *NORM/CATV* switch on the back of the VCR to the *NORM* position if you have a home antenna system. Set the switch to the *CATV* position if you have cable-TV.
- [] Program active channels into VCR's scan list (press *SELECT LOCK*, then press *AUTO PROG*, wait about one minute, and then press *SELECT LOCK* again).
- [] Delete or add individual channels into scan list as desired. (Detailed instructions on page 11.)
- [] Select "VCR Channel".
First set the *CH3/CH4* switch on the back of the VCR to either channel 3 or 4 and then tune your TV to the same channel. This is called the "VCR Channel".
- [] Learn how to use the *VCR/TV* switch.
 - When you press the *VCR/TV* switch and the indicator light above the switch turns on, the VCR is in the "VCR mode" and your TV must be tuned to the VCR Channel (channel 3 or 4). Your TV will then display on channel 3 or 4 whatever tape the VCR is playing or whatever channel the VCR is tuned to.
 - When the indicator light above the *VCR/TV* switch is out, the VCR is in the "TV mode" and your TV will work like it always did before you connected the VCR.

Remote Control

Before you use the remote control unit supplied with your VCR, install the batteries (instructions below). Most of the remote's buttons do the same things as the buttons with the same names on the front of your VCR, and you can use whichever one is more convenient at the moment. The remote control is also used for setting the clock and programming the timer.

Since the remote control operates the VCR by infrared light, it is immune to electrical and sound interference. However, you must aim the remote unit directly at the VCR. There cannot be any obstructions between them.

Battery Installation

The batteries supplied with your remote control are packed separately. To install them in the hand unit:

1. Turn the hand unit over and remove the cover of the battery compartment.
2. Insert the batteries so that their positive (+) ends contact the positive terminals in the battery compartment. These are marked (+) in the bottom of the compartment.
3. Replace the cover.

Remote Unit
(Back View)

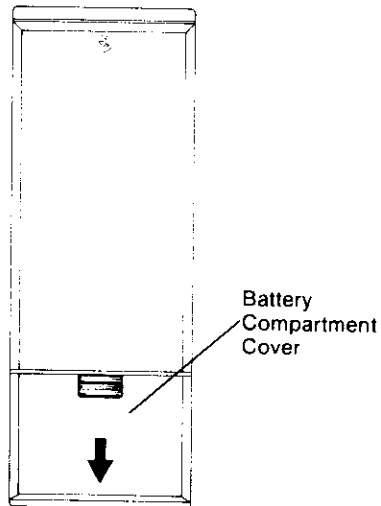

Replace the batteries when your VCR fails to respond to the remote control. Replacement batteries are widely available. Use size "AA" 1.5 volt cells. Alkaline type batteries are preferred. Good batteries should last a year or more in normal service.

Avoid laying the remote control upside down or placing things on top of it. This could depress the buttons and discharge the batteries. If you are not going to use the hand unit for a month or more, it is wise to remove the batteries to avoid leakage.

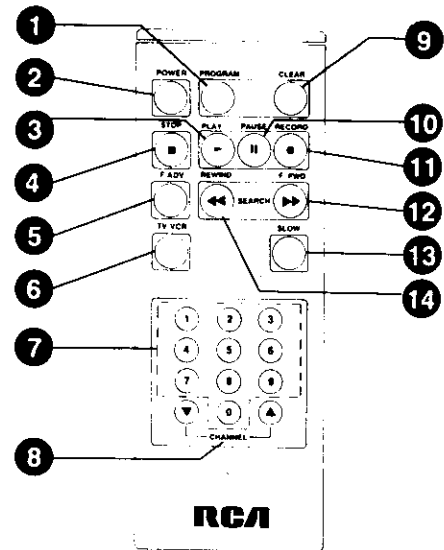

- 1 **PROGRAM:** Used for setting the clock and programming the timer.
- 2 **POWER:** Same as the *POWER* button on the VCR.
- 3 **PLAY:** Same as the *PLAY* button on the VCR.
- 4 **STOP:** Same as the *STOP* button on the VCR.
- 5 **F. ADV.:** (Frame Advance) Advances the picture from frame to frame during stop-action viewing. This is explained on page 17.
- 6 **TV VCR:** Same as the *VCR* button on the VCR.
- 7 **Number buttons:** Select any channel (whether or not it is in the "Tuner Scan List") by pressing two buttons. (Press 0 and then 8 for channel 8). The number buttons are also used for setting the clock and programming the timer.
- 8 **CHANNEL ▲ and ▼:** Same as the *CHANNEL* buttons on the VCR.
- 9 **CLEAR:** Used for setting the clock and programming the timer.
- 10 **PAUSE:** Same as the *PAUSE* button on the VCR.
- 11 **RECORD:** Same as the *RECORD* button on the VCR. (Press both *PLAY* and *RECORD* to begin recording.)
- 12 **F. FWD/SEARCH ►►:** Same as the *F. FORWARD/SEARCH ►►* button on the VCR.
- 13 **SLOW:** Used to begin Slow-Motion play. Press *PLAY* to resume normal playing speed.
- 14 **REWIND/SEARCH ◄◄:** Same as the *REWIND/SEARCH ◄◄* button on the VCR.

Note: Selected models of RCA color TV receivers and monitor/receivers feature hand units that will also remotely control your VCR. See page 26 for details.

Setting the Clock

Here are some things you should know before you set the clock:

- When you first plug in your VCR, the clock will read "----".
- The buttons for setting the clock are on the remote hand unit.
- While you are setting the clock, the display on the TV screen will prompt you through the procedure.
- If you press a wrong digit, press *CLEAR* repeatedly until the incorrect digit flashes, and then enter the correct digit.
- If you enter an illogical time or date (13th month for example) a question mark will appear instead of the illogical entry. Simply enter the correct digit to replace the question mark.
- The clock must be set to the correct time before you can program the timer for unattended recordings or use Express Recording (XPR)
- If power is interrupted for an extended period, you will have to reset the clock and re-enter your programs in the timer.

[1] Turn on your TV and tune it to the VCR Channel (channel 3 or 4). The VCR Channel is explained on page 11.

Press *PROGRAM* on the remote hand unit

This "menu" will appear on the TV.

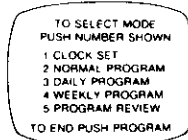

Press "1" to set the clock

[2] The display prompts you to set the time.

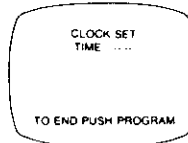

Set the time by pressing two digit buttons on the remote for the current hour and two more for the minute.

(For example, press 0 2 1 5 for 2:15.)

[3] The display prompts you to select AM or PM.

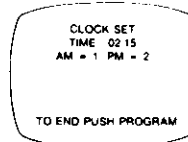

Press "1" for AM or press "2" for PM.

[4] The display prompts you to set the date.

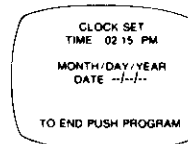

Set the date by pressing six digits in order for the month, day, and year. (For example, press 0 7 0 6 8 6 for July 6, 1986.)

Always press "0" before single-digit months and days.

[5] The day of the week will appear when you have entered all six digits for the date.

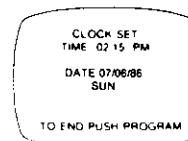

Press *PROGRAM* to start the clock. (Note that the display on the VCR will show the correct time after you press *PROGRAM*.)

Press *PROGRAM* again to return to the program you were watching.

First Recording and Playback

First Recording and Playback

This page gives the basic steps for recording and playback. You should practice them until you can do them without referring to the manual. To save time, we suggest you record for only two or three minutes.

The first drawing shows how to make a recording and the second one shows how to play it back and turn off the VCR. The operating notes at the bottom of the page are keyed to the step numbers for quick reference if you have a problem or need more information.

Making a Recording

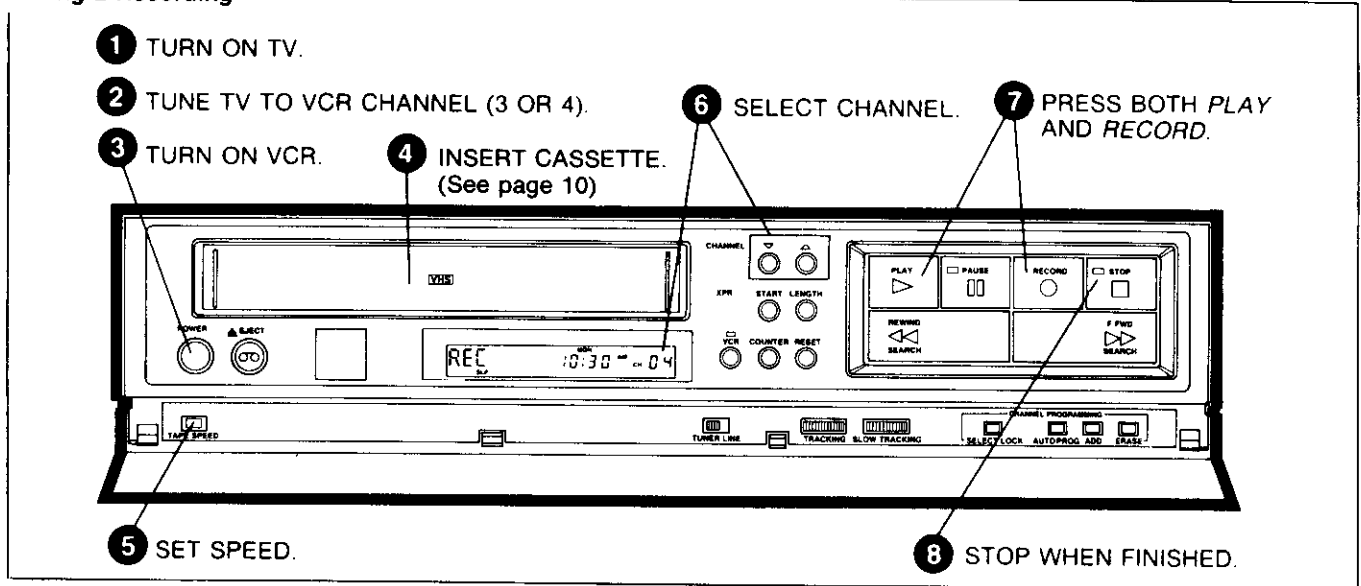

Playing It Back

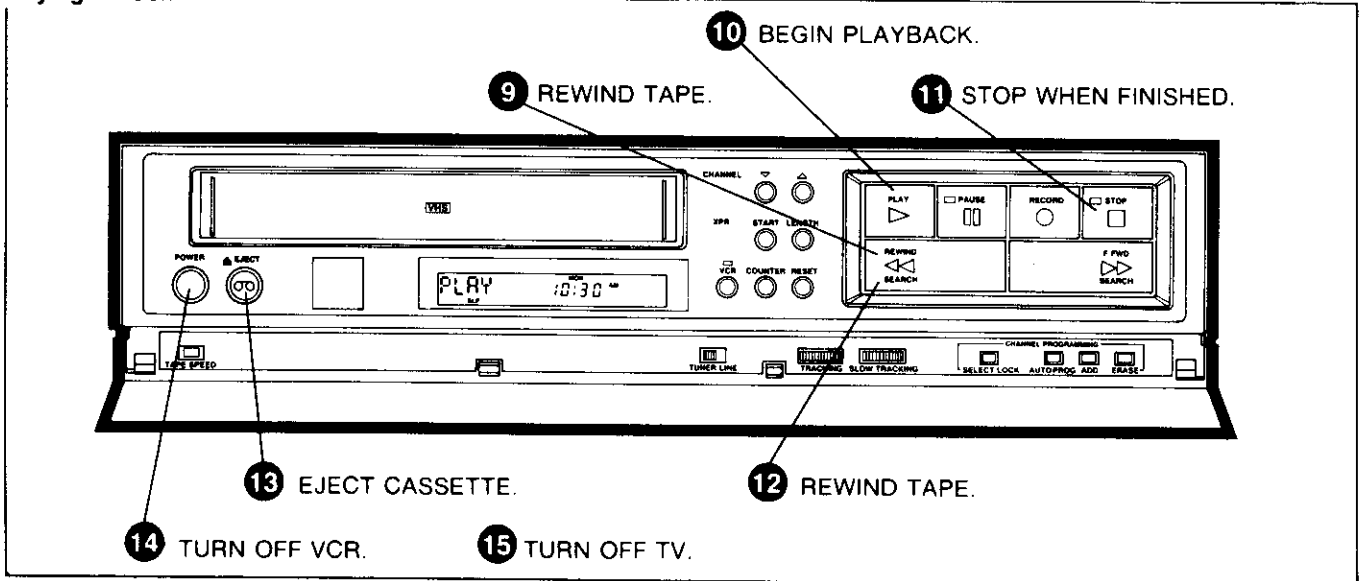

Operating Notes

- 2 The channel switch on the back of the VCR and the channel selector on your TV must be set to the same channel.
- 3 If the light in the *STOP* button flashes, wait until it lights continuously.
- 5 Normally record at *SLP*. Recording speeds are compared on page 9.
- 6 If there is no picture on the TV and no channel numbers in the display, check that the *TUNER/LINE* switch is set to *TUNER*. It may be necessary to fine tune the TV for best picture and sound.
- 7 *REC* appears in the display when the VCR is recording.
- 8 If you don't want to play back the tape, skip to Step 12 in the second drawing.
- 9 *REW* appears in the display during rewind. When rewinding is finished this display goes off and the light in the stop button turns on again.
- 10 *PLAY* appears in the display when the VCR is playing.

Operating Controls (Detailed Information)

The uses of the controls for basic operation are on page 10. Now that you are familiar with the basic procedure for recording a TV program and playing it back, you are ready to learn the rest of the control functions.

The controls of your VCR are designed so that:

- Accidentally pressing a wrong button will not damage the VCR or the cassette.
- Non-essential buttons are disabled during recording to help you avoid accidental interruptions.

- Operation of the VCR is automatic whenever this is feasible.
- Automatic recording functions (Timer and XPR) will not disturb normal TV viewing.
- If you run out of tape during playback or normal recording, the VCR rewinds it and stops automatically. If tape runs out during Timer or Express Recording, the VCR stops without rewinding.
- Because of these features, the functions of some control buttons depend on the condition of the VCR at the time they are used.

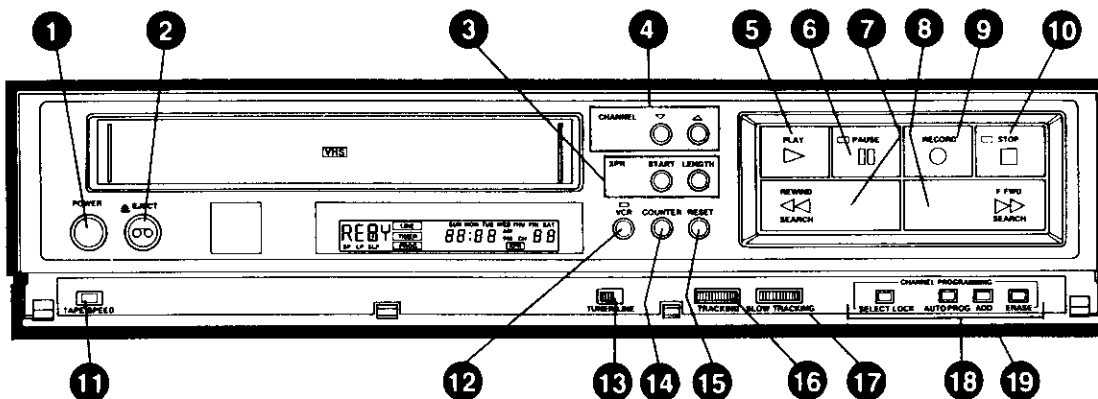

1 POWER: When the VCR is turned off, the timer is automatically turned on if it has been programmed. When the VCR is turned on, the timer is automatically turned off. Your VCR will not make a timer recording if it is already turned on at the time.

The power button operates differently during Timer and Express recording. Press **POWER**, **STOP**, **POWER** in that order to stop and turn off the VCR.

The VCR will stop and turn off if you press the **POWER** button during Recording, Playback, or Fast Forward. If you press it during rewind, the VCR will continue rewinding until it is finished and then turn off.

2 EJECT: The **EJECT** button will not operate when the VCR is recording. It will eject the cassette in any other mode of operation.

3 XPR: Complete information is on page 22.

4 CHANNEL: Complete information is on page 10.

5 PLAY: The **PLAY** button is normally used to begin playback when the VCR is stopped. It is also used to switch to slow-motion operation when the VCR is paused during playback for stop-action viewing. Slow Motion and Stop Action are explained on the next page. The **PLAY** button is inactive when the VCR is recording.

6 PAUSE: Pausing during a recording stops the tape so that nothing will be recorded. When you press the **PAUSE** button a second time, recording resumes immediately. Pausing during playback produces a Stop-Action picture and pressing it again resumes normal playback. **REC** or **PLAY** in the display unit flashes during a pause. Additional information about Recording Pause and Stop Action is on the next page.

7 REWIND/SEARCH ◀◀: This is the **REWIND** button when the VCR is stopped. Once you have pressed it, the VCR will rewind to the beginning of the tape (or to a counter reading of 0000) unless you press the **STOP** button.

This same button becomes **SEARCH ◀◀** when the VCR is playing. Picture Search is explained on page 17.

The **REWIND/SEARCH** button is inactive during recording.

8 F.FWD/SEARCH ▶▶: This is the **FAST FORWARD** button when the VCR is stopped. Once you have pressed it, the tape will continue to "fast forward" until you press the **STOP** button. If you do not press the **STOP** button, the VCR will "fast forward" to the end of the tape and then automatically rewind to the beginning of the tape and stop. Refer to "Memory Stop" on the page 17 for more information.

This same button becomes **SEARCH ▶▶** when the VCR is playing. Picture Search is explained on page 17.

The **FAST FORWARD** button is inactive during recording.

9 RECORD: The **RECORD** button never functions unless you press **PLAY** at the same time. Normally you press both buttons to begin recording when the VCR is stopped. You can switch directly from Playback to Recording by pressing both buttons when the VCR is playing.

10 STOP: The **STOP** button will stop whatever the VCR is doing, both the normal functions of Record, Play, Rewind, and Fast Forward; and the Special-Effects functions described on the next pages.

11 TAPE SPEED: The Special Effects features of your VCR (Stop Action, Picture Search, and Slow Motion) work best on tapes recorded at the lowest tape speed — Super Long Play or SLP. Since this speed also uses the least tape, it is generally preferred for all the recording you do.

12 VCR: Complete information is on pages 10 and 12.

13 TUNER/LINE: Selects the program source to be recorded. The **TUNER** position is used for recording from the VCR's built-in tuner. The **LINE** position is for recording video and audio connected to the input jacks on the back of the recorder. When the switch is in the **LINE** position, the warning light comes on in the display unit and the channel indicator is turned off. Always check that this switch is set to **TUNER** when you are going to make a timer recording.

14 COUNTER: Press this button once to turn on the tape counter and press it again to restore the normal clock display. Refer to "Tape Counter" and "Memory Stop" on the next page.

15 RESET: Refer to "Tape Counter" and "Memory Stop" on the next page.

16 TRACKING: Refer to "Tracking Adjustment" on the next page.

17 SLOW TRACKING: Refer to "Slow Motion" on page 17.

18 CHANNEL PROGRAMMING: See page 11 for complete details.

19 DISPLAY RESET: Push the switch within the hole located on the bottom of VCR if the indication or operation of the display appears abnormal.

Special Effects and Features

Pause During Recording

Press the *PAUSE* button when you are recording to prevent recording short passages of unwanted material. Press the *PAUSE* button again when you are ready to resume recording. Avoid pausing for more than three or four minutes, because the spinning heads that do the recording are still in contact with the tape and will eventually wear off the active material. This will cause streaks or spots in the picture when you play the worn part of the tape (called dropouts).

Pause for Stop-Action Playback

Press the *PAUSE* button during playback to stop the action. This lets you examine all the details of the scene, similar to looking at a single frame of a movie film. When you are ready to resume normal playback, press the *PAUSE* button again.

The following suggestions will help you get the most out of this feature:

- Your VCR is designed to give the best picture when you use stop-action on tapes recorded at SLP. If you expect to use stop-action frequently during playback, a sports event, for instance, be sure to record at SLP speed.
- The stop-action picture may tend to jump up and down slightly. Adjust the control marked *V LOCK* on the back of the VCR to reduce this jitter. Once you have made this adjustment, you probably won't have to do it again unless you use stop-action on a tape that was recorded on a different VCR. (A small amount of vertical jitter is normal.)
- Using stop-action on a single frame of the picture for a long time can wear the tape, as explained in "Pause During a Recording." For this reason you should use *STOP* instead of *PAUSE* to interrupt playback for an extended time. The VCR will automatically switch from Pause to Stop after five minutes.

Frame Advance

Frame Advance is a special feature that lets you view one Stop-Action "frame" after another. Press *PAUSE* to begin stop-action viewing. Then press *F. ADV* on the remote control each time you want to go on to the next "frame" of the scene. Press *PAUSE* to resume playback at normal speed.

Slow Motion

If a tape is playing, press *SLOW* on the remote control to begin slow-motion viewing. When you are using Stop-Action viewing (Pause during Play) press *PLAY* to begin Slow Motion. Sound is turned off during slow motion.

To return to normal viewing speed, press *PLAY*.

It is normal to see some streaks and spots in the picture during slow motion. Use *SLOW TRACKING* to eliminate them as much as possible. Turn the control first in one direction and then in the other until you get the best picture. Notice that the center position of the control is marked. You should return it to this position when you are through with the tape.

The VCR will automatically switch from Slow Motion to normal play after about five minutes.

Picture Search

The buttons for Rewind and Fast Forward become the Picture-Search buttons when you are playing a tape. When you press *SEARCH ►►* the VCR plays at a higher speed until you release the button. When you press *SEARCH ◄◄* the VCR reverses from the normal direction and plays the tape backward at high speed until you release the button. The sound is turned off during picture search because it would not be understandable at the high speed.

Expect to see some streaks in the picture when you are searching. The picture will be best for tapes recorded at SLP speed, although it can be viewed from tapes recorded at the other speeds.

Tape Counter

If you always reset the tape counter when you insert a tape, you can note the counter reading at the beginning of each program you record for future reference. The label kit provided with RCA tapes can be used to list programs and counter readings.

1. Press *COUNTER* to display the tape counter in place of the time.
2. Press *RESET* to set the counter to 0000.

Note: It is normal for tape to stretch slightly when it passes through the VCR. For this reason, the counter may not return exactly to 0000 after rewind, and it is likely to read 9998 or 9999. This is normal.

Memory Stop

When you press *COUNTER* to turn on the counter display, you automatically turn on the "Memory Stop" feature. When the counter is displayed, the VCR will stop automatically at 0000 whenever you use *REWIND* or *FAST FORWARD*. If you are rewinding, simply press the Rewind button again to continue to the end of the tape.

If you press *FAST FORWARD* and the counter never reads 0000 between that point and the end of the tape, the VCR will continue to the end of the tape, switch to Rewind, and then stop when the counter reads 0000.

Since you can reset the counter to 0000 at any point on the tape, Memory Stop is convenient for finding the beginning of a recording, or the beginning of a particular segment you want to repeat.

This is the procedure to use when you are going to start recording somewhere beyond the start of the tape.

1. Turn on the VCR and press *COUNTER* to obtain the counter reading. (Pressing it again returns the clock display).
2. Use *FAST FORWARD* and *STOP* to locate the point where you will begin recording. Then press *RESET* before you begin recording.
3. Press *STOP* when you are finished recording and then press *REWIND*. The cassette will rewind to counter reading 0000 and stop.
4. Press *PLAY* to view the segment you have selected, or press *REWIND* to rewind the cassette completely.

Use this procedure during playback to mark a point to be repeated.

1. When you see the beginning of the part you want to view several times, use *SEARCH ◄◄* to locate a point slightly before the desired scene.
2. Release the *SEARCH* button to resume normal playback, and press *RESET* just before the desired scene appears.
3. When you have played to the end of the scene in question, press *STOP* and then *REWIND*. The tape will rewind to the beginning of the scene and stop.
4. Press *PLAY* to view the scene again.
5. Repeat Steps 3 and 4 as many times as you like.

Tracking Adjustment

When you play tapes that were not recorded on the same VCR, black and white streaks may appear in the picture. Adjust the *TRACKING* control, located behind the auxiliary control door, in either direction to remove them. Return it to its center position when the tape has finished playing.

Quick Reference Guides

Recording With TV Off

It is not necessary to have your TV on when you record.

- 1 TURN ON VCR.
- 2 INSERT CASSETTE.
- 3 SELECT SPEED.
- 4 SET TO TUNER.
- 5 SELECT CHANNEL.
- 6 PRESS BOTH *PLAY* AND *RECORD*.
- 7 STOP WHEN FINISHED.

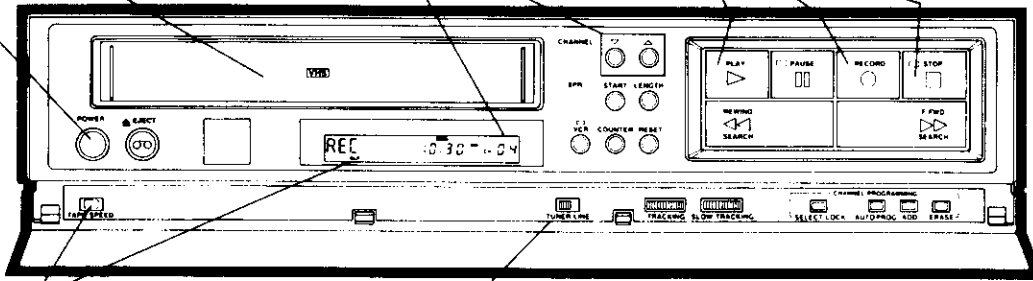

Normal TV Viewing

Follow the two steps in the drawing for normal TV viewing. To view UHF stations, just tune your TV to the channel, regardless of what the VCR is doing. If you have a TV Monitor/Receiver and the VCR's audio and video outputs

are connected to it, switch the TV to "Tuner Input" and select the channel you want, regardless of what the VCR is doing.

- 1 TURN POWER OFF OR TURN VCR LIGHT OFF
- 2 OPERATE TV AS USUAL.

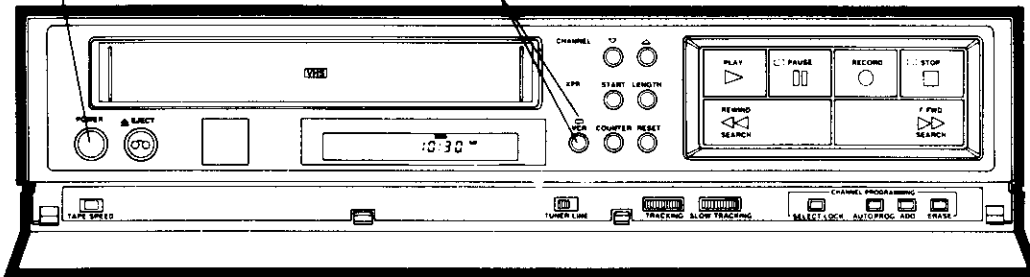

Recording and Viewing the Same Program

- 1 TURN ON TV.
- 2 TUNE TV TO VCR CHANNEL (3 OR 4).
- 3 TURN ON VCR.
- 4 INSERT CASSETTE.
- 5 SET SPEED.
- 6 VCR LIGHT ON.
- 7 SET TO TUNER. PRESS PAUSE TO INTERRUPT RECORDING. PRESS IT AGAIN TO RESUME.
- 8 SELECT CHANNEL.
- 9 PRESS BOTH *PLAY* AND *RECORD*.
- 10 STOP WHEN FINISHED.

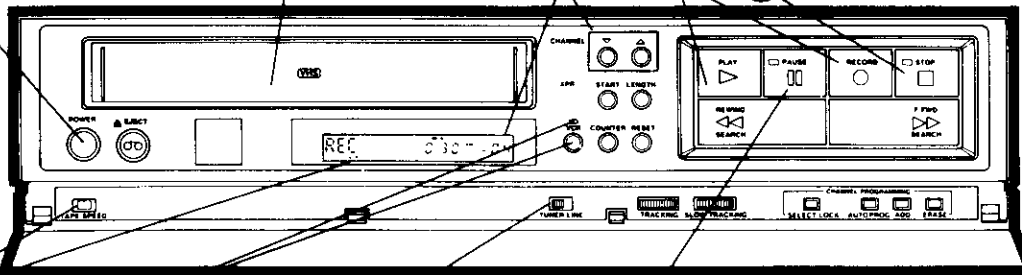

Note: If you want to view another VHF or Cable-TV channel after you start recording, press the VCR/TV switch so the light above it goes off. Then select the channel on the

TV. If you want to view a UHF channel after you start recording, simply tune the TV to the channel.

Quick Reference Guides (continued)

Recording and Viewing Different Programs

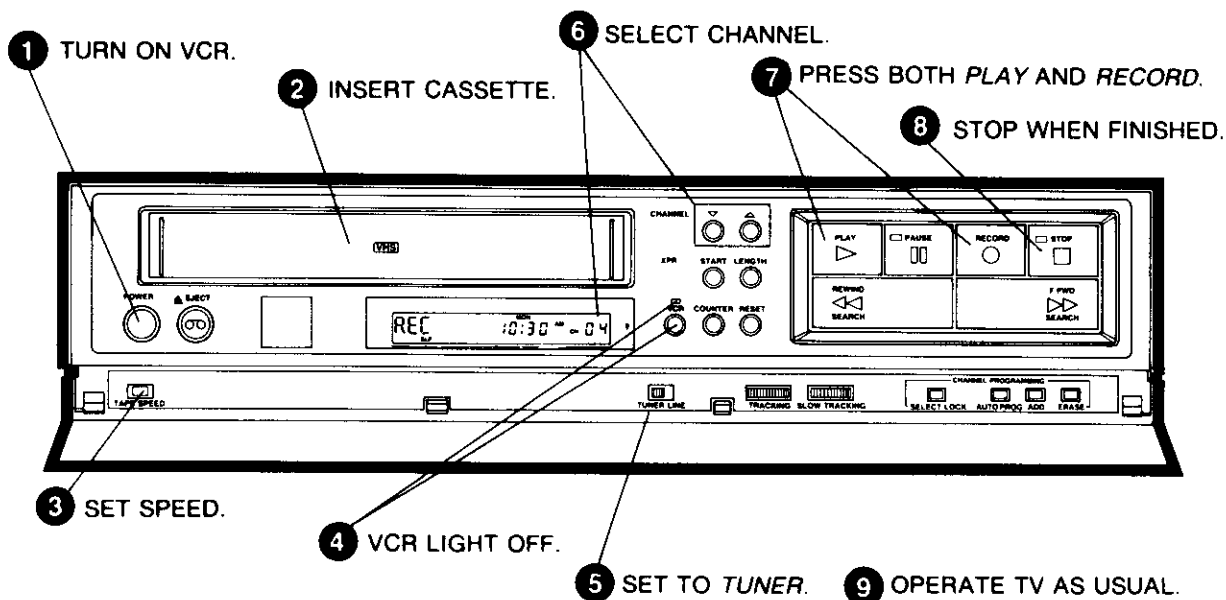

Note: If you want to view what is being recorded, press the *VCR/TV* switch to turn on the light and then tune your TV to the VCR channel (3 or 4).

Basic Playback

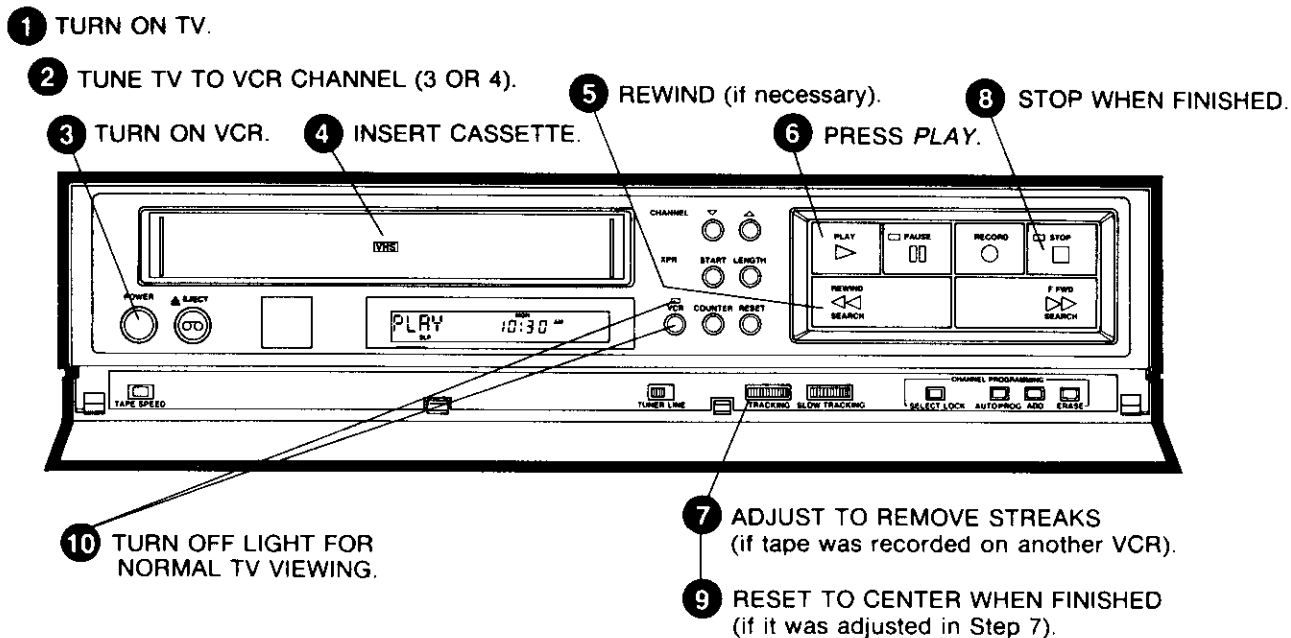

Note: The VCR light automatically comes on when you start playback so you do not need to press the *VCR/TV* switch.

Recording from Another VCR

To copy (dub) tapes, connect the two VCR's as shown below. Use shielded audio/video cables (such as RCA #AH002 or #AH005). The connections from the recording VCR to your TV are the ones you normally use. It is preferable to play the original tape on the same machine that was used to record it.

CAUTION: The unauthorized recording of television programs and other materials may infringe the rights of others.

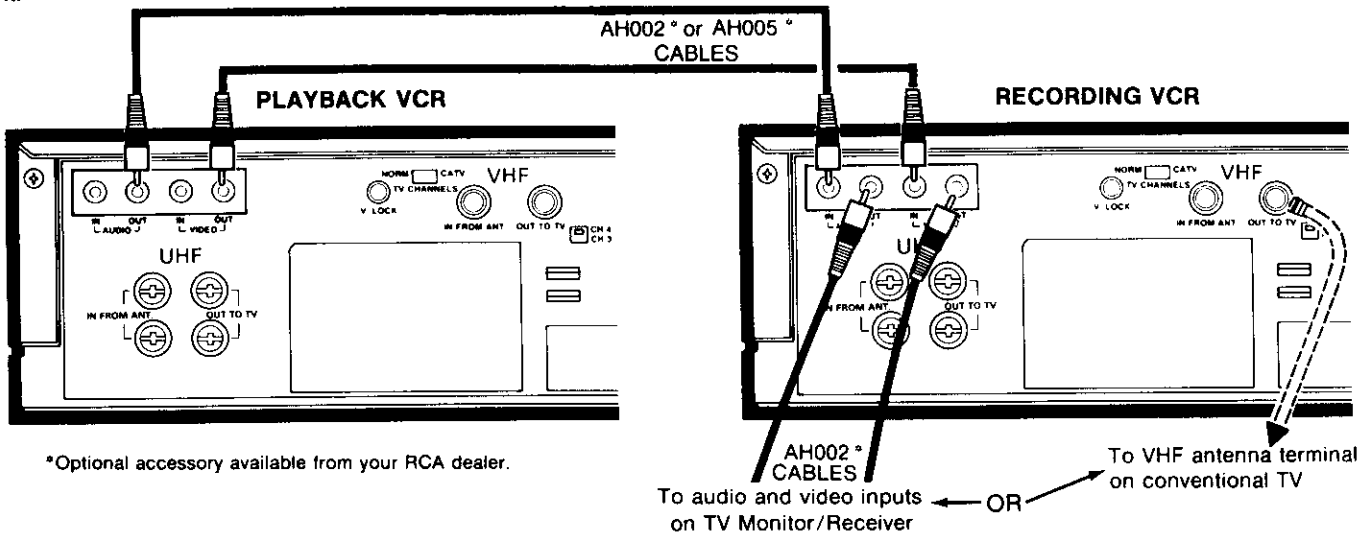

*Optional accessory available from your RCA dealer.

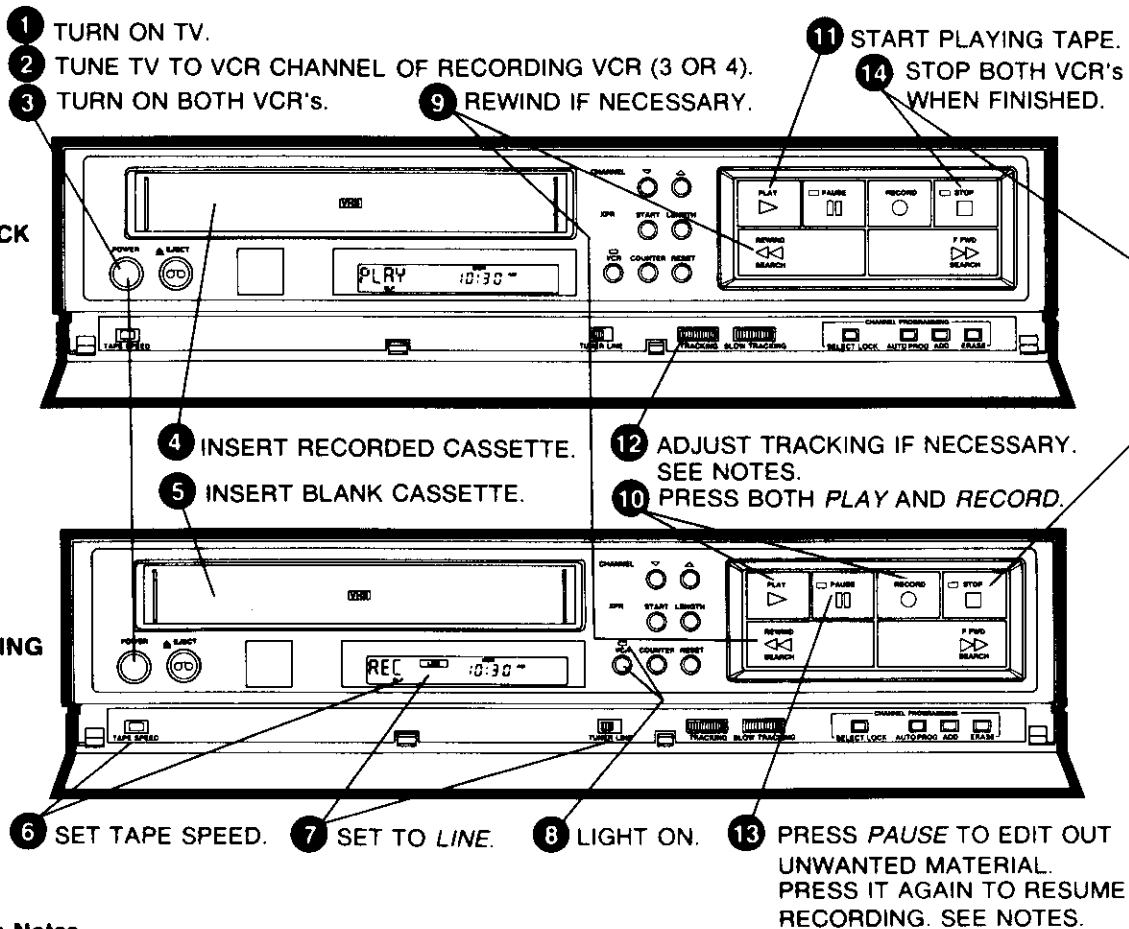

Operating Notes

Adjust the *TRACKING* control (Step 12) if streaks appear in the TV picture. This may happen if the cassette was not originally recorded on the same VCR that you are using to play it. After you adjust the tracking, stop both VCR's and start over with Step 9.

Use the *PAUSE* button (Step 13) for brief pauses. If you want to pause for more than three or four minutes, stop the VCR by pressing *STOP*. When you are ready to resume, press both *PLAY* and *RECORD*.

Camera Recording

In addition to the camera itself, you will need a **Camera AC Power Supply** (RCA Model CPS03 for use with RCA cameras). Plug the camera cable into the power supply and then connect the cables from the power supply to the VCR as the drawing shows. The connections from the VCR to your TV are the same ones you normally use.

To start recording press *PLAY* and *RECORD* on the VCR. Use the *PAUSE* button on the VCR to start and stop recording. If you want to pause for more than three or four minutes, stop the VCR by pressing *STOP*. When you are ready to resume, press both *PLAY* and *RECORD*.

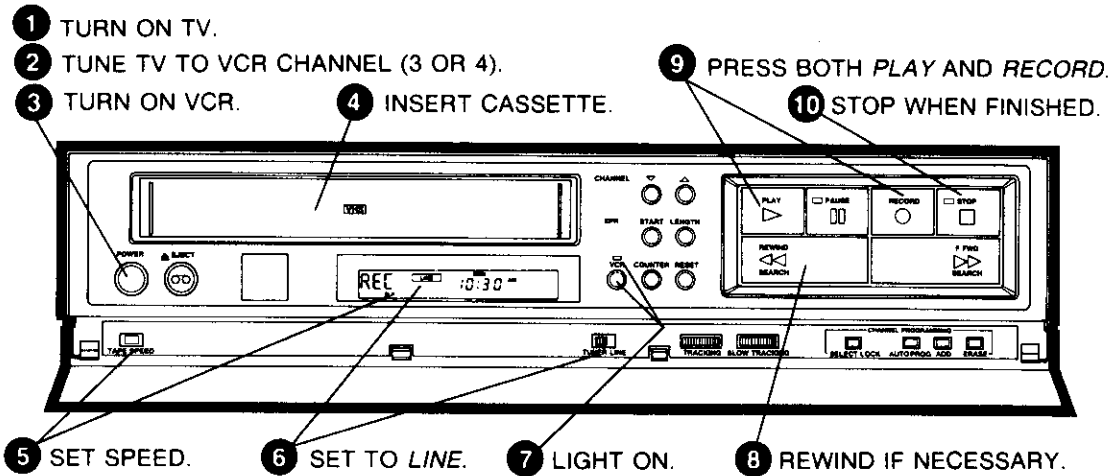
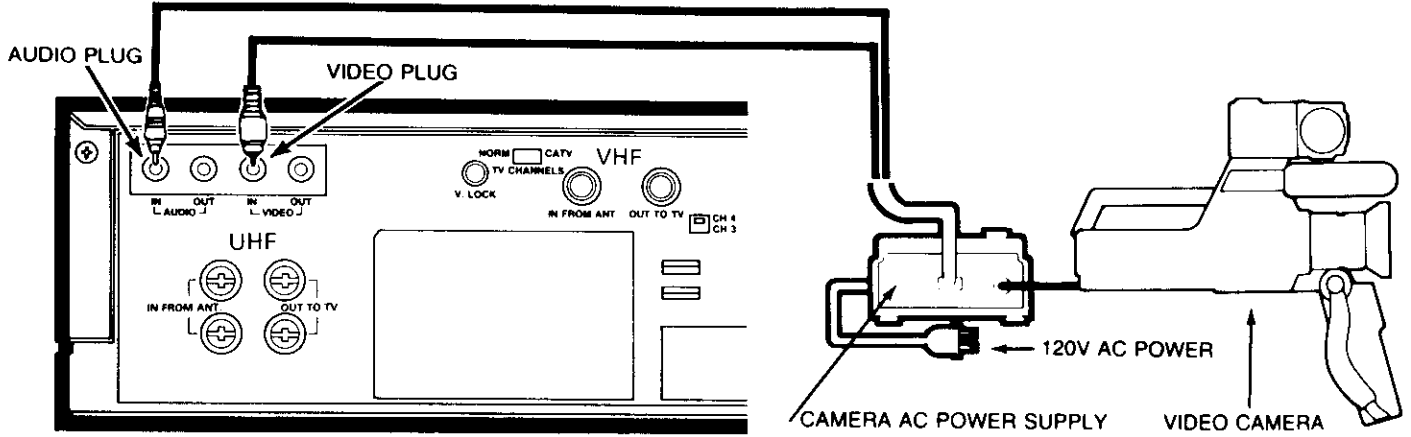

Express Recording

Express Recording (*XPR*) lets you record up to four hours without programming the timer. It also allows you to start (or continue) recording immediately or to delay recording up to 24 hours. When the recording is finished, the VCR will turn off automatically.

Note: Although you do not have to program the timer, the clock must be set before you can Express Record.

IMMEDIATE START

If you want the VCR to start recording immediately or to continue a recording you've already started, follow the simplified instructions at the right labeled "Immediate Start".

DELAYED START

If you want the VCR to delay recording, follow the simplified instructions at the right labeled "Delayed Start".

Only two buttons are used to Express Record:

XPR

START

LENGTH



Simplified Instructions

Immediate Start

1. Press **LENGTH** twice.
2. Press **LENGTH** to select desired recording time [0:30 (30 minutes) to 4:00 (4 hours)].

Delayed Start

1. Press **START** (Clock will skip to next half-hour).
2. Keep pressing **START** until desired start time appears in display.
3. Press **LENGTH** to select desired recording time [0:30 (30 minutes) to 4:00 (4 hours)].
4. Press **POWER** to turn off VCR.

To Cancel Delayed-Start XPR (Before Recording Begins)

- Press **LENGTH** until the display shows 0:00.

To Stop XPR (After Recording Starts)

- Press **LENGTH** until display shows 0:00.
- or—
- Press **POWER** and then **STOP** within ten seconds.

Detailed Instructions

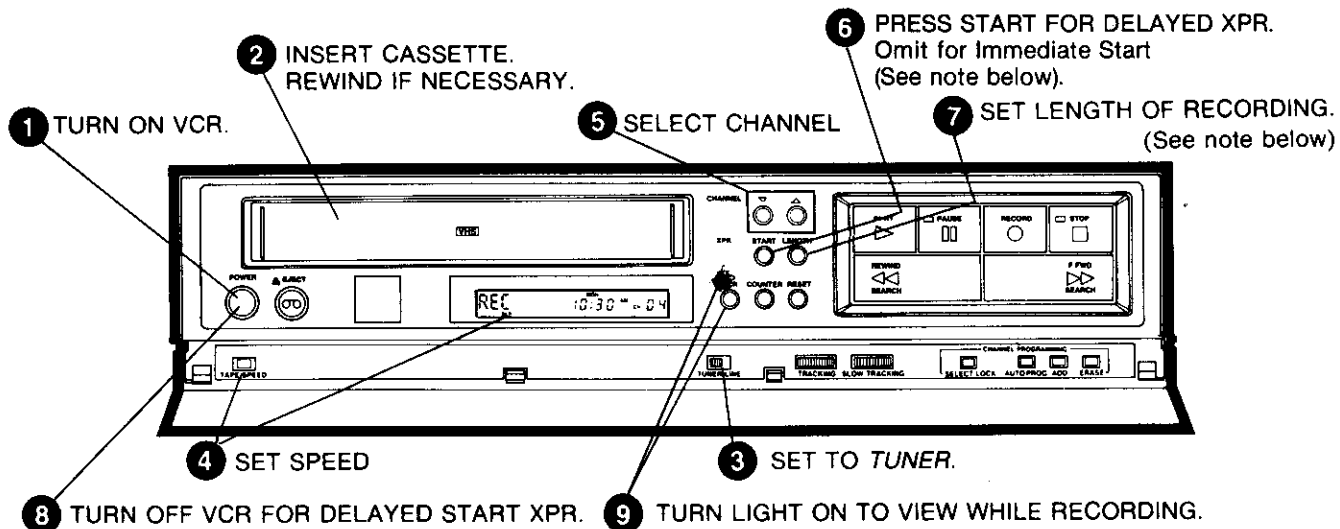

Note for Step 6

- The first time you press the **START** button, *XPR* will appear in the display and the clock will skip to the next half-hour. Examples: If you press the button at 9:35 AM the clock will skip to 10:00 AM; if you press it at 8:15 PM the clock will skip to 8:30 PM.
- Each additional time you press **START**, the clock will advance another 30 minutes. The time that is displayed is the time when the recording will start.
- After you have set the starting time, you must set **LENGTH** within 8 seconds. Otherwise, *XPR* will disappear and the clock will return to the actual time. Then you must reset the start time.

Note for Step 7

- Press the **LENGTH** button at least twice. The first keypress only starts the *XPR* recording; it does not advance the recording length.
- Increase the recording time by pressing the **LENGTH** button additional times. The clock display shows the amount of recording time you have set. [from 0:30 (30 minutes) to 4:00 (4 hours)]
- The time remaining is constantly displayed during *XPR*. You can extend the time whenever you want by pressing **LENGTH**.
- When the recording time has expired, the VCR turns off and the clock display returns to current time.

Programming the Timer

The programmable clock/timer permits unattended recording of up to four different TV programs. The timer is actually a small computer which will turn on the VCR at the time you select, record for a selected length of time, and then turn off the VCR . . . all automatically without you being there.

You can program the timer to do the following:

- Record a program on a single day up to one year away. [NORMAL PROGRAM]
- Record a program at the same time Monday thru Friday. [DAILY PROGRAM]
- Record a program on one certain day of every week. [WEEKLY PROGRAM]

Things to know before you start:

- You can program the timer up to one year before the TV program is to be recorded.
- You can correct an error in the program any time before the last step by pressing CLEAR repeatedly until the digit to be corrected is flashing. Then enter the correct digit and continue the programming sequence.

Simplified Programming Instructions

1. Turn on VCR and Tune your TV to the VCR channel (channel 3 or 4).
2. Press PROGRAM on remote hand unit.
3. Watch the display on the TV screen—it will prompt you through the rest of the programming exercise.
4. Turn off the VCR.

- [1] Turn on the TV and tune it to the VCR channel (channel 3 or 4) so you'll be able to see the programming display on the TV screen. Make sure the VCR's clock is set to the correct time. The timer cannot record at the right time if the clock is set incorrectly. Reset the clock if necessary.

Press PROGRAM on the remote hand unit.

The programming "menu" appears on the TV screen.

TO SELECT MODE
PUSH NUMBER SHOWN
1 CLOCK SET
2 NORMAL PROGRAM
3 DAILY PROGRAM
4 WEEKLY PROGRAM
5 PROGRAM REVIEW
TO END PUSH PROGRAM

Press "2" to enter a Normal Program, "3" to enter a Daily Program, or "4" to enter a Weekly Program.

- [2] The display will prompt you to select a Program Number.

Four program numbers are available and you can enter different programming instructions in each one. All four program numbers will be flashing because none of them have been used. If the timer has been programmed, the number that was used will stay on instead of flashing. You must clear a program number before the same number can be used again. See "Clearing a Timer Program" on the next page.

NORMAL PROGRAM
PROGRAM 1 2 3 4
SELECT PROG NUMBER

Press a digit from 1 to 4 on the remote to select the program number you want to program.

- [3] The display will prompt you to select a channel number.

NORMAL PROGRAM
PROGRAM 1
CH . . .
TO END PUSH PROGRAM

Press two digits for the channel to be recorded. (for example, press 0 4 for channel 4).

- [4] The display will prompt you to enter the recording start time.

NORMAL PROGRAM
PROGRAM 1
CH 04
TIME ON . . .
TO END PUSH PROGRAM

Press four digits, two for the hour and two more for the minute. For example, press 0 6 0 0 for 6:00. (Always press "0" before a single-digit hour or minute.)

Programming the Timer (continued)

- [5] The display will prompt you to select either AM or PM.

NORMAL PROGRAM
PROGRAM 1
CH 04
TIME ON 06 00
AM 1 PM 2
TO END PUSH PROGRAM

Press "1" for AM or "2" for PM.

- [6] The display will prompt you to select the stopping time.

NORMAL PROGRAM
PROGRAM 1
CH 04
TIME ON 06 00 PM
TIME OFF
TO END PUSH PROGRAM

Press four digits, two for the hour and two more for the minute. For example, press 0 8 0 5 for 8:05. (Always press "0" before a single-digit hour or minute.)

- [7] The display will prompt you to select either AM or PM.

NORMAL PROGRAM
PROGRAM 1
CH 04
TIME ON 06 00 PM
TIME OFF 08 05
AM=1 PM=2
TO END PUSH PROGRAM

Press "1" for AM or "2" for PM.

- [8] The display will show "START DATE" followed by the current date and day.

NORMAL PROGRAM
PROGRAM 1
CH 04
TIME ON 06 00 PM
TIME OFF 08 05
START DATE 07/19/88
SAT
TO END PUSH PROGRAM

If you want to start recording on a future date, press four digits (two for the month and two for the day). Press "0" first for a single-digit month or day. For example, press 0 8 0 5 to begin recording on August 5.

If you want to start recording on the current day, skip to Step 9.

The year and day of the week are displayed automatically when you finish.

- [9] Press PROGRAM to enter your program and return to the original display. Additional programs may be entered by repeating steps 2-9.

TO SELECT MODE
PUSH NUMBER SHOWN
1 CLOCK SET
2 NORMAL PROGRAM
3 DAILY PROGRAM
4 WEEKLY PROGRAM
5 PROGRAM REVIEW
TO END PUSH PROGRAM

If you have no other programs to enter, press PROGRAM again.

- [10] Turn off the VCR.

Checking the Timer Programs

Programs can be checked whenever the VCR is not recording.

1. Press PROGRAM on the remote hand unit to display the programming menu.
2. Press 5 (Program Review).
The TV screen will display for ten seconds the information you entered for the lowest program number. Then the display changes to the next higher program number, and so on until all program information has been displayed.
3. Press 5 again if you want to view the next program information without waiting ten seconds.
4. When you are finished, press PROGRAM to erase the on-screen display.

Clearing a Timer Program

1. Press PROGRAM on the remote hand unit to display the programming menu.
2. Press 5 (Program Review).
The TV screen will display for ten seconds the information you entered for the lowest program number. Then the display changes to the next higher program number, and so on until all program information has been displayed.
3. Press 5 again if you want to view the next program information without waiting ten seconds.
4. Press CLEAR when the program information you want to clear is displayed.
5. Press PROGRAM to erase the on-screen display.

Notes:

- Normal timer programs clear automatically when the recording is finished, but daily and weekly programs remain in the timer indefinitely.
- All programs are erased if power is interrupted for more than approximately ten minutes.

Timer Recording

The information on this page tells you how to set up your VCR for Timer Recording *after you have programmed the timer.* (The programming instructions are on pages 23-24.) When you have finished programming the timer, follow the steps in the drawing to prepare for timer recording. We suggest that you make one or more short timer

recordings for practice so you won't be disappointed later on.

If you have a Daily or Weekly program in the VCR timer, you should check the steps in the drawing sometime before the recording time to be sure that your VCR is ready to record.

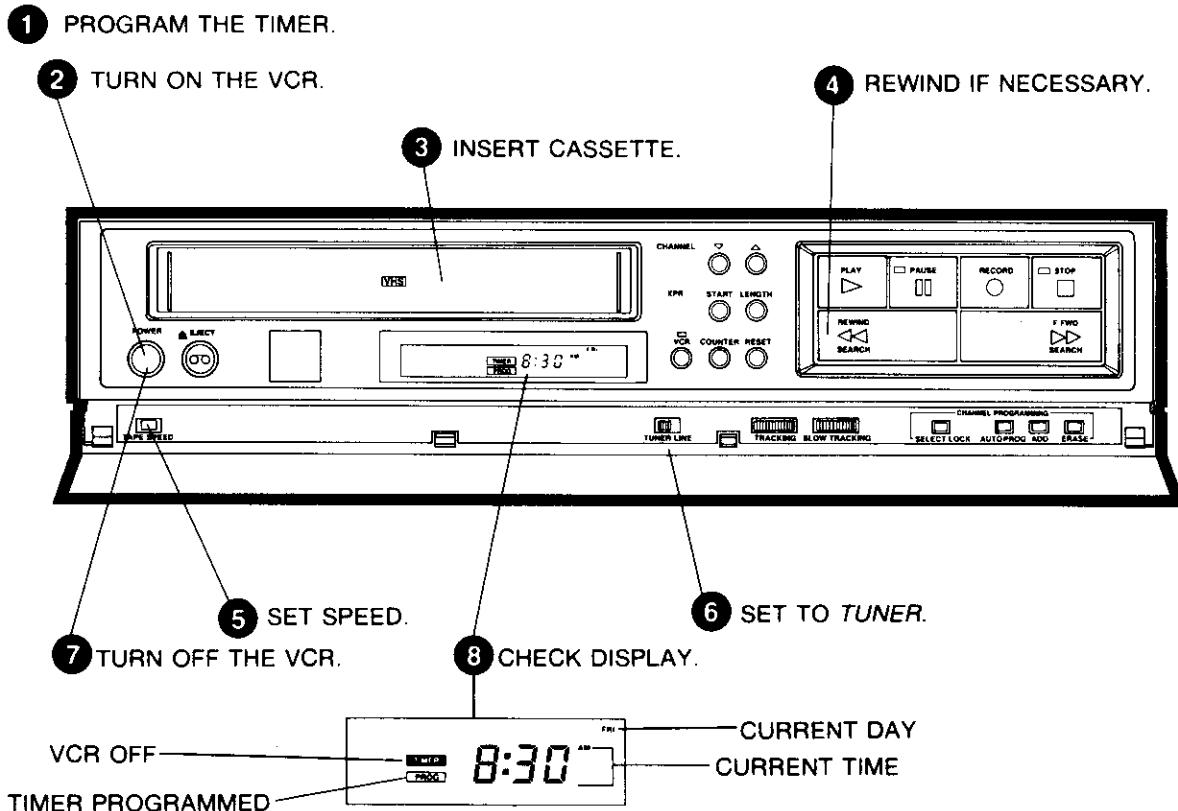

Timer Recording Checklist

Before your VCR timer can record a TV broadcast, all the conditions listed here must be fulfilled. They are presented as a checklist you can use until you are familiar with your VCR.

- Cassette inserted in the VCR. ("TIMER" flashes if not.)
- Cassette has its safety tab in place. (If not, the cassette is ejected.) (See page 9.)
- Cassette length and recording speed are adequate for program(s) to be recorded.
- Cassette rewound to beginning or to desired place on tape.
- Tuner/Line switch set to *TUNER*.
- Clock set to correct time and date.
- Timer has been programmed. ("PROG" will be displayed.)
- Power has been turned off. ("TIMER" appears only if the timer is programmed and the VCR is off.)

Programming Reminders

- The timer light will flash if you have programmed the VCR but forgotten to insert a cassette.
- The VCR will automatically eject the cassette after you have programmed the timer and turned off the VCR if the cassette has its safety tab removed. This is to remind you to put in a new cassette or cover the safety tab. (See page 9.)

TV Viewing During a Timer Recording

When the VCR turns on automatically to make a timer recording, it does not disturb whatever program you may be watching at the time. Press the *VCR/TV* switch to turn on the VCR light if you want to monitor the recording.

Stopping a Timer Recording While in Progress

Press *POWER* and then press *STOP* within 10 seconds. (Press *POWER* once more to turn off the VCR). This erases a Normal program from the timer's memory, but a Daily or Weekly program will record on the next scheduled day.

Alternate Remote Control Units

Selected models of RCA color TV receivers and monitor/receivers feature infrared hand units that will also remotely control your VCR. Only the buttons that are used for controlling your VCR are described here. These buttons have generally the same functions as the ones with the same names on the front panel of the VCR, but there are some differences.

- Any VCR tuner channel may be selected by pressing two of the Digit buttons on the hand unit. Press **0** first to select tuner channels 1 through 9.

- Separate buttons turn the VCR on and off.
- Simply press the Record button to record. It is not necessary to press the Play button at the same time.

Note: When you use *CHANNEL UP* or *DOWN* on the Digital Command Center hand unit, the VCR uses its internal scan list of channels, not the scan list that you programmed into the hand unit for controlling the TV.

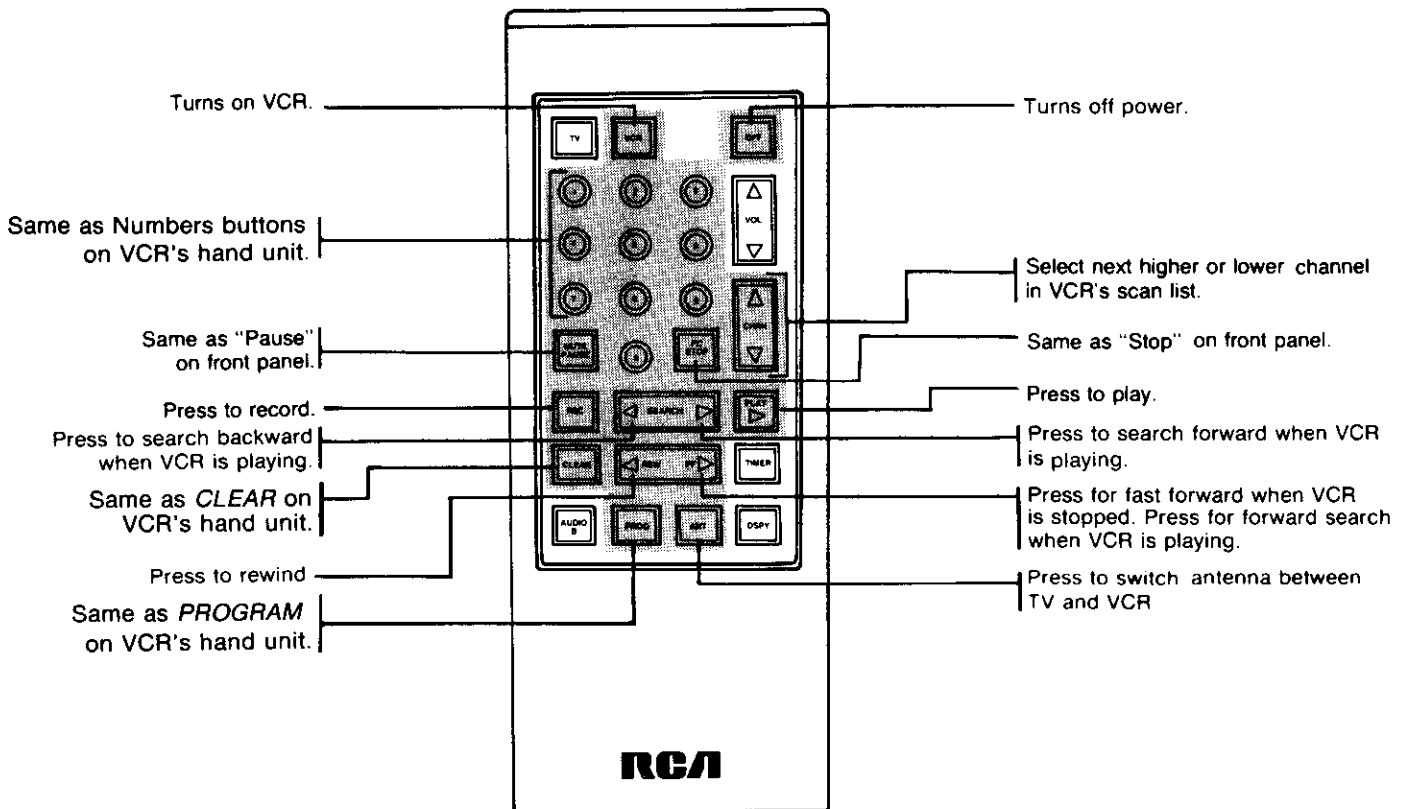
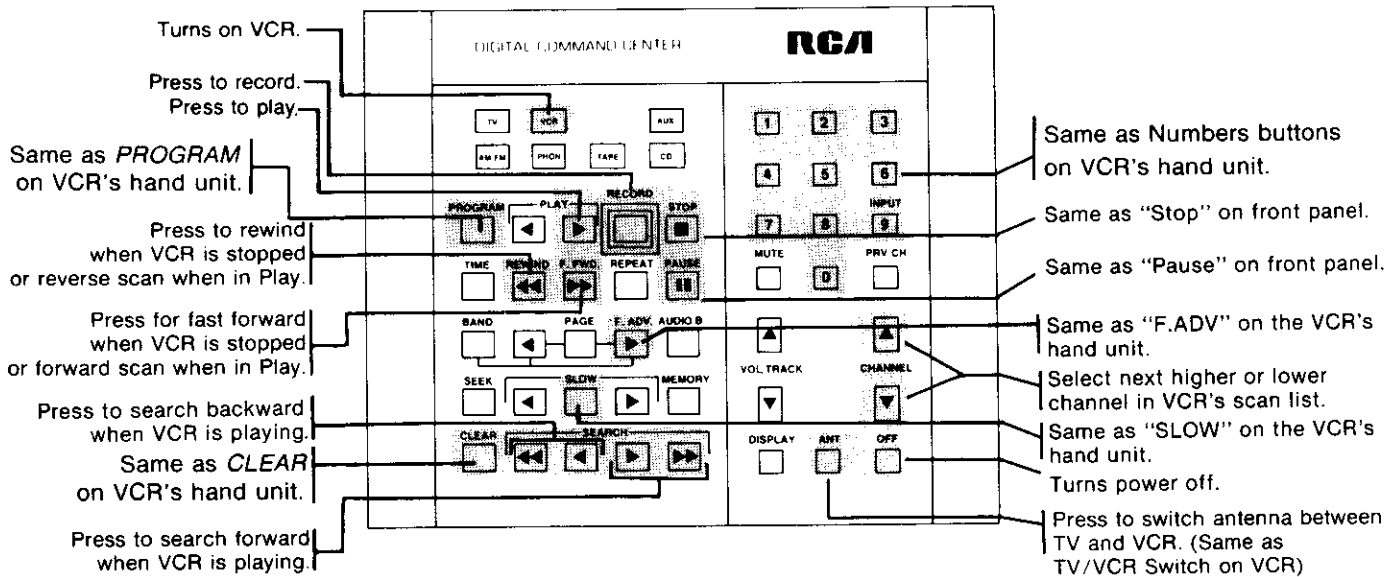

Optional Accessories

Several accessories are available that will enable you to expand your home video system. You may also find some of these items helpful when installing your VCR. A few accessories are pictured here to briefly familiarize you with the different types that are available. Although RCA Part Numbers are listed for your convenience, other accessory brands are available through most electronic supply stores and RCA video dealers.

Video Cameras and Camcorders

See your RCA dealer for complete details on the wide selection of Color Video Cameras and Camcorders (combination camera/recorder) that is available for use with your new VCR.

CABLES

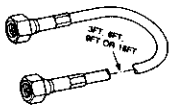

Cable designed for use with VCRs, Video Cameras, or any other equipment requiring 75-ohm "F"-type interconnecting cables.

**AH037 - 3 ft; AH008 - 9 ft;
AH007 - 6 ft; AH009 - 16 ft**

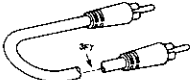

AH036

3' general-purpose coaxial cable for use in audio and video applications. It is fitted with RCA phono-type connectors and is used with VCRs, Monitors, and other related audio and video equipment.

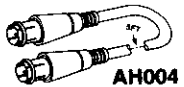

AH004

Provides quick-connect application of 75-ohm "F"-type cable. Used with VCRs, Video Cameras, TV receivers, and other electronic devices.



AH002

A 5' shielded audio/video cable specifically designed for video and audio use with video cameras and VCR equipment.

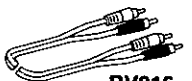

RV016

A twin-jacketed dual-conductor audio cable used for connection of stereo speakers to stereo video instruments. It is two color-coded and is equipped with RCA phono-plugs at each end.

SWITCHES



AH028

This is an economy two-position 75-ohm coaxial switch which performs the same functions outlined for the AH041 switch, shown below.

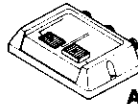

AH041

This is a 2-position 75-ohm coaxial switch (sometimes referred to as an A-B switch) used for switching a single signal source to two separate output devices, such as a cable-TV input to a TV set or VCR.

SPLITTER /COMBINER

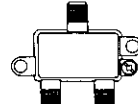

AH047

Used as a splitter to divide a signal from a single 75-ohm source so that it may be fed to two separate devices. For example, a single 75-ohm antenna lead-in signal split to feed two TV receivers. When used as a combiner, signals from two sources are fed through two inputs to a single output.

HEAD CLEANING CASSETTE

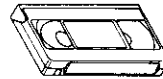

The AV009W head-cleaning kit uses a special cleaning cassette which you insert in the VCR just as you would a standard tape cassette.

Specifications

| | |
|--------------------------------|--|
| Format | VHS |
| Record/Playback System: | 3-Head: 2 video record/ playback heads, 1 special effects head |
| Video Signal: | EIA standard: NTSC color |
| Antenna | 75-ohm external VHF antenna terminal 300-ohm external UHF antenna |
| Tuner | |
| Type | Auto-programming frequency synthesis, 119 channels |
| Broadcast Channels: | VHF 2 - 13, UHF 14-83 |

| | |
|---------------------------|--|
| Cable-TV Channels: | Midband A-1 and A-2 Midband A through I (14 - 22) Superband J through W (23 - 36) Hyperband W+1 through W+12 (37 - 48) |
| Power Requirements | 120V AC, 60Hz |
| Power Consumption | 32 watts |
| Weight | 15.9 lbs. |
| Dimensions | 3-7/8" High 17-1/8" Wide 12-9/16" Deep |

Note: Specifications subject to change without notice.

RCA Limited Warranty Video Cassette Recorder

What does your warranty cover:

- Any defect in material or workmanship.

For how long after purchase:

- Ninety days for labor charges.
- One year for parts.

The warranty period for rental VCR's begins with the first rental.

What will RCA do:

- Pay any RCA Authorized Servicenter the labor charges to repair your VCR.
- Provide new or, at out option, rebuilt replacement parts for the RCA Authorized VCR Servicenter to make the repairs.

How do you get service:

- Take your VCR to any RCA Authorized VCR Servicenter or to the RCA Service Company. For their names and locations, ask your dealer or RCA Distributor, or look in the Yellow Pages.
- Show the service technician your Warranty Registration or evidence of purchase date.
- Pick up your VCR when repairs are completed.

What does your warranty *not* cover:

- Transportation to and from the Servicenter.
- Customer instruction. Your Owner's Manual provides information regarding operating instructions and user controls. For additional information ask your dealer.
- Installation and set-up service adjustments.
- Signal reception problems caused by external antenna or cable systems.
- Damage from misuse or neglect.
- Cleaning of video/audio heads, which is normal maintenance.
- VCR's which have been modified or incorporated into other products.
- VCR's purchased or serviced outside the USA.

How does state law relate to this warranty:

- This warranty gives you specific legal rights, and you may also have other rights which vary from state to state.

What if you purchased your VCR in Canada:

- Refer to the Canadian Warranty.

Si un livret d'instructions en français n'est pas inclus avec votre appareil, vous pouvez en obtenir un (INDIQUER LE NUMÉRO DE MODÈLE VOTRE NOM ET VOTRE ADRESSE) en vous adressant à:

RCA Inc.

Service des données techniques
5575 av. Royalmount
Ville Mont-Royal, Quebec, Canada
H4P 1 J8



RCA Corporation
Consumer Electronics Division
600 N Sherman Dr, PO Box 1976
Indianapolis, Indiana 46206

Trademark(s) © Registered
Marca(s) Registrada(s)
Part Number 2822 432-1
Printed in Japan
E72118
4649574