

Trinitron® Color TV

KV-27HSR10

KV-32HSR10

Operating Instructions

Before operating the unit, please read this manual thoroughly and retain it for future reference.

Owner's Record

The model and serial numbers are located at the rear and the unit. Record these numbers in the spaces provided below. Refer to them whenever you call upon your Sony dealer regarding this product.

Model No. KV-32HSR10 Serial No. 123456789

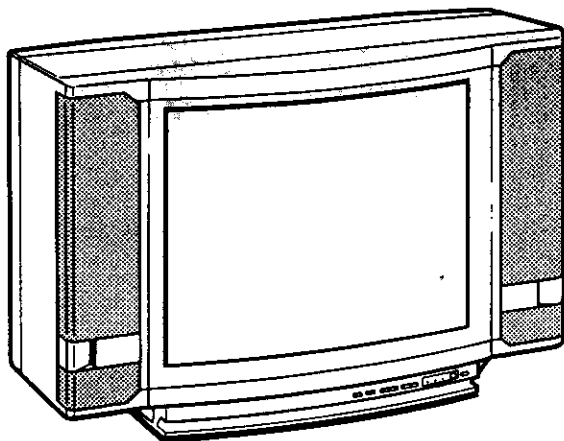

WARNING

To prevent fire or shock hazard, do not expose the unit to rain or moisture.

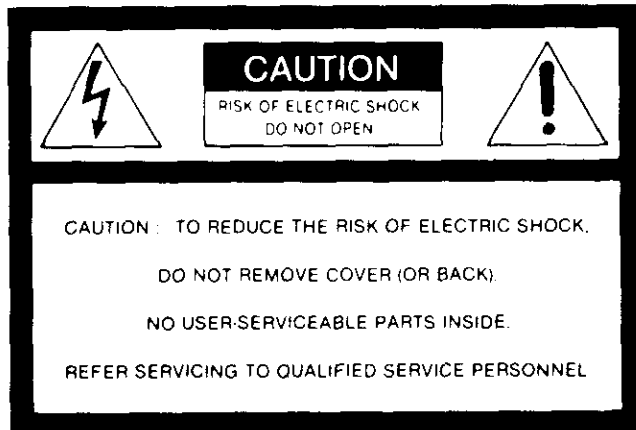

CAUTION:

TO PREVENT ELECTRIC SHOCK, DO NOT USE THIS POLARIZED AC PLUG WITH AN EXTENSION CORD, RECEPTACLE OR OTHER OUTLET UNLESS THE BLADES CAN BE FULLY INSERTED TO PREVENT BLADE EXPOSURE.

Note to CATV system installer in the U.S.A.

This reminder is provided to call the CATV system installer's attention to Article 820-22 of the NEC that provides guidelines for proper grounding and, in particular, specifies that the cable ground shall be connected to the grounding system of the building, as close to the point of cable entry as practical.

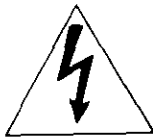

This symbol is intended to alert the user to the presence of uninsulated "dangerous voltage" within the product's enclosure that may be of sufficient magnitude to constitute a risk of electric shock to persons.



This symbol is intended to alert the user to the presence of important operating and maintenance (servicing) instructions in the literature accompanying the appliance.

Table of Contents

Before Use

Features	4
Precautions	5
Location of controls	6

Set up

Connecting the TV antenna/cable	10
Connecting other equipment	12
Presetting TV channels	16

Operation

Watching TV programs	18
Enjoying the convenient features	20
Receiving a Multichannel TV Sound program	20
Muting the sound	20
Keeping the channel displayed	20
Using the SLEEP timer	20
Switching quickly between two channels	20
For more natural sound reproduction	20
Adjusting the picture and sound	21
Adjusting the picture	22
Adjusting the sound	24
Using the GUIDE function	25
Setting the clock	26
Setting the ON/OFF timer	28
Setting the channel block	30

General

Specifications	31
Troubleshooting	back cover

This instruction manual covers two models: KV-27HSR10 and KV-32HSR10. The difference between them is only the picture size.

Features

This color TV features a Microblack™ TRINITRON® picture tube for a high resolution, high contrast picture.

- **Sound Retrieval System (SRS®)*** enhances the natural sound of any stereo source.
- **Multi-band VHF/UHF/CATV tuner** receives up to 125 cable channel for a total of 181 possible off-air and cable channels.
- **Built-in MTS (Multichannel TV Sound) decoder** enables reception of stereo programs and Second Audio Program (SAP) broadcasts.
- **S VIDEO IN** jack which is connected to the S video output jack on the VCR allows superior playback pictures.
- **Variable audio output jacks** enable reproduction of TV or video sound through an audio system.
- **Monitor output jacks** allow VTR recording of the picture and sound being monitored on the TV.

* Sound Retrieval system (SRS) reproduces the ambience and dynamic of the original live performance so that you can enjoy the sound as if you were at the concert hall or in the recording studio. SRS enables you to enjoy the optimum sound from anywhere in the room.

(●) SOUND RETRIEVAL SYSTEM

The (●) Sound Retrieval System is manufactured by Sony Corporation under license from the Hughes Aircraft Company, a subsidiary of GM Hughes Electronics. It is covered by U.B. Patent No. 4, 748, 669. Other U.S. and foreign patents pending.

(●), Sound Retrieval System and SRS® are trademarks of the Hughes Aircraft Company, a subsidiary of GM Hughes Electronics.

Supplied Remote Commander provides you many other convenient features.

- **Commander** allows you to operate the TV, a Sony VCR and a multi disc player from a distance.
- **Guide function** allows you to set the clock, timer, channel block, while reading the instructions of the on-screen guide.
- **Automatic programming** to preset all receivable channels instantly.
- **JUMP** button enables switching quickly between two channels.
- **Sleep timer** automatically turns off the TV after approximately one hour.
- **ANT/AUX button** permits one-touch selection of pay cable TV channels when a converter is connected.
- **Internal clock** for the current time display

And other features for a high quality picture...

- **New Dynamic picture™ system** adjusts picture contrast automatically to produce more detail in both bright and dark areas of every scene.
- **New Dynamic Color™ system** assures accurate, life-like skin tones and pure whites.
- **Colorpure Filter™** produces fine picture detail without color spill or color noise.
- **VM (VELOCITY MODULATION) circuitry** produces clean and sharp black and white contrasts. (Only for KV-32HSR10)
- **Dynamic Focus™ circuitry** automatically focuses the scanning electron beam for enhanced sharpness over the entire picture, especially in the corners. (Only for KV-32HSR10)
- **Trinitone™ control** allows you to adjust the color temperature (tint) of the picture for the most pleasing color.

Precautions

Safety

- Operate the unit only on 120 AC.
 - One blade of the plug is wider than the other for purpose of safety and will fit into the power outlet only one way. If you are unable to insert the plug fully into the outlet, contact your dealer.
 - Should any liquid or solid object fall into the cabinet, unplug the unit and have it checked by qualified personnel before operating it any further.
 - Unplug the unit from the wall outlet if it is not going to be used for several days or more. To disconnect the cord, pull it out by the plug. Never pull the cord itself.
-

Installation

- To prevent internal heat build-up, do not block the ventilation openings.
 - Do not install the unit in a hot or humid place or in a place subject to excessive dust or mechanical vibration.
-

Cleaning

Clean the unit with a slightly damp soft cloth. Use a mild household detergent. Never use strong solvents such as thinner or benzene as they might damage the finish of the cabinet.

Repacking

Retain the original carton and packing materials for safe transport of this unit in the future.

Use of this television receiver for other than private viewing of programs broadcast on UHF or VHF or transmitted by cable companies for the use of the general public may require authorization from the broadcaster/cable company and/or program owner.

If you have any questions or problems concerning your unit, please contact your nearest Sony dealer.

For details safety precautions, see the leaflet "IMPORTANT SAFEGUARDS".

Location of Controls

Refer to the pages indicated in ● for details.

Front panel

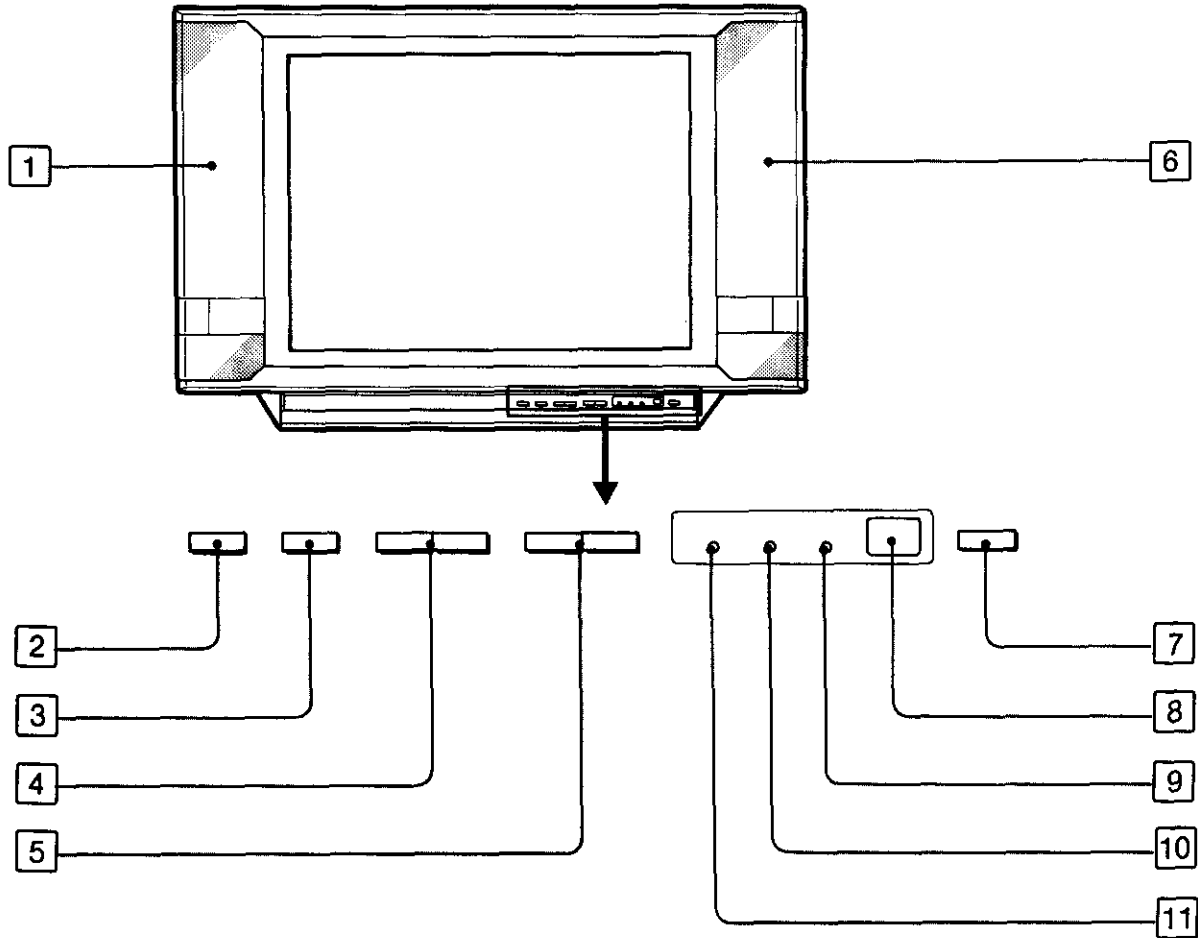

1 Left speaker (tweeter and woofer)

2 (●) SRS (Sound Retrieval System) button ●

3 TV/VIDEO button ●

4 VOLUME buttons ●

5 CHANNEL buttons ●

6 Right speaker (tweeter and woofer)

7 POWER switch ●

8 Remote sensor ●

9 SLEEP indicator ●

10 STEREO indicator ●

11 TIMER indicator ●

Rear panel

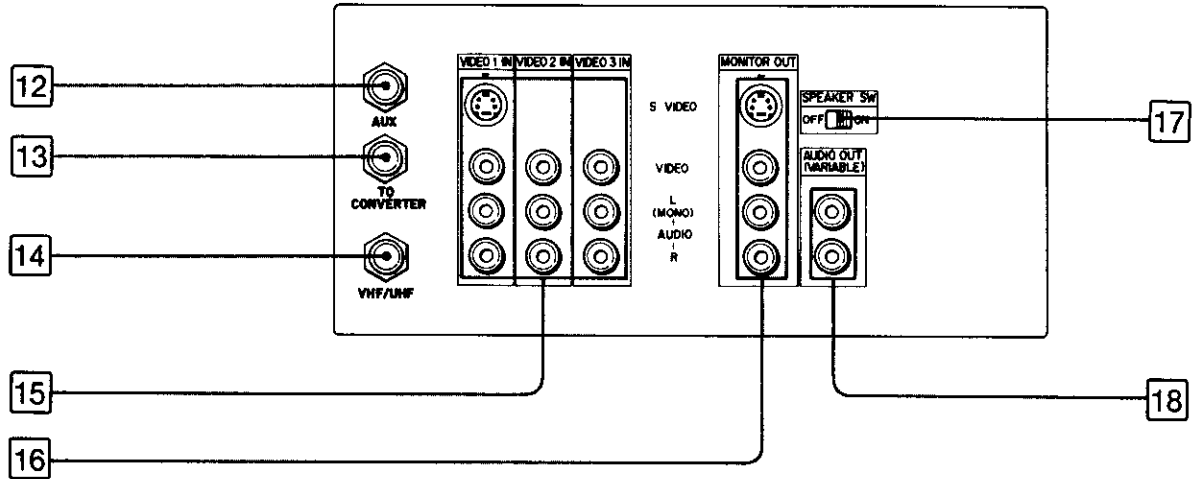

12 AUX (auxiliary) terminal ①

13 TO CONVERTER terminal ②

14 VHF/UHF antenna terminal ③

15 VIDEO 1, 2, 3 IN jacks (phono jacks) ④

16 MONITOR OUT jacks (phono jacks) ⑤

17 SPEAKER SW (switch) ⑥

18 AUDIO OUT (VARIABLE) jacks (phono jacks) ⑦

Remote Commander RM-763

Refer to the pages indicated in ● for details.
The buttons with * mark have the same function as the buttons with the same or similar mark on the TV.

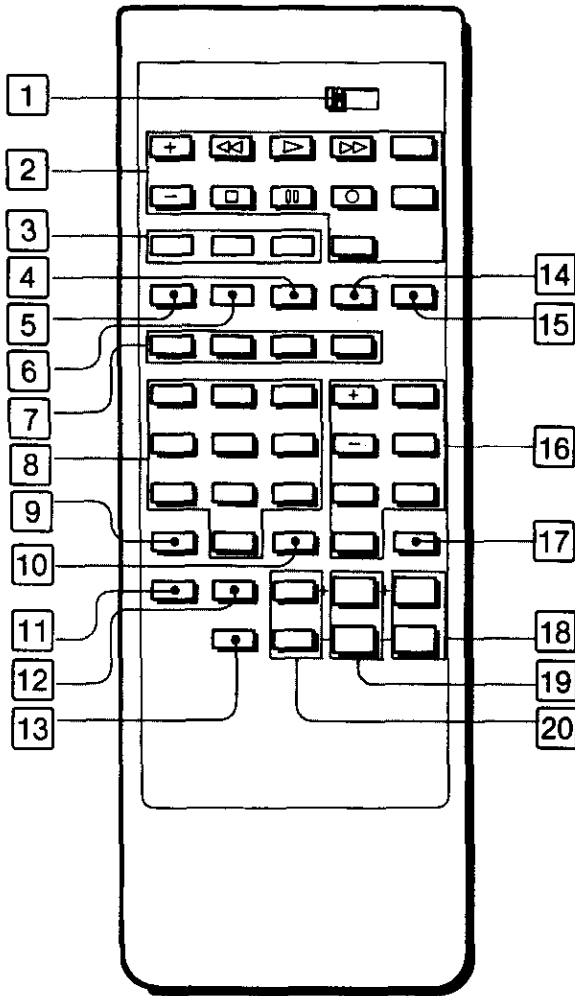

- 1 VTR 1/2/3/MDP (multi disc player) selector ●
- 2 Sony VCR/multi disc player operation buttons ●
- 3 Channel presetting buttons ● ●
- 4 ANT/AUX (antenna/auxiliary) button ●
- 5 MUTING button ●
- 6 CABLE button ●
- 7 Input select buttons (TV, VIDEO 1, VIDEO 2, VIDEO 3)* ●
- 8 Channel number buttons ●
- 9 DISPLAY button ●
- 10 ENTER button ● ●
- 11 TIME button ●
- 12 MTS (multichannel TV sound) button ●
- 13 SRS (sound retrieval system) button* ●
- 14 SLEEP button ●
- 15 POWER button*
- 16 A/V WINDOW (audio and video adjusting) buttons ●
- 17 JUMP button ●
- 18 CH (channel) scan buttons*
- 19 VOL (volume) control buttons*
- 20 PICTURE buttons ●

Installing Batteries

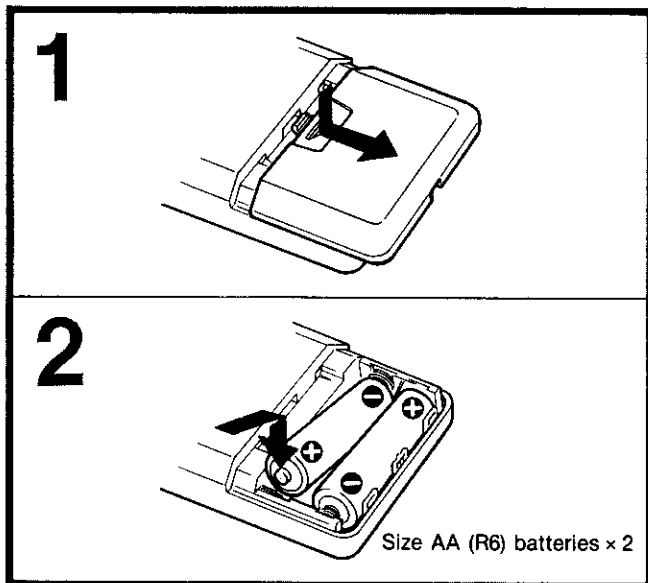

Battery life

In normal operation, batteries will last up to half a year. If the unit does not operate properly, the batteries might be exhausted. Replace both batteries with new ones.

To avoid damage from possible battery leakage

Remove the batteries when the commander will not be used for a long time.

Connecting the TV Antenna/Cable

Either an indoor antenna or outdoor antenna can be connected. For better quality picture, connecting an outdoor antenna is recommended.

Cable TV reception is only possible by connecting a cable supplied by your local cable operator.

To Connect a VHF, UHF, or VHF/UHF Combination Antenna* or CATV Cable

- 1** Check the cable type and prepare the cable end using the appropriate connector.

75-ohm coaxial cable (round)

Attach an optional F-type connector.

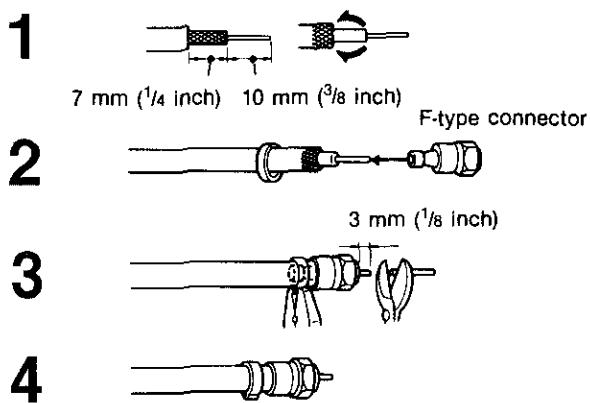

300-ohm twin-lead cable (flat)

Attach the supplied antenna connector.

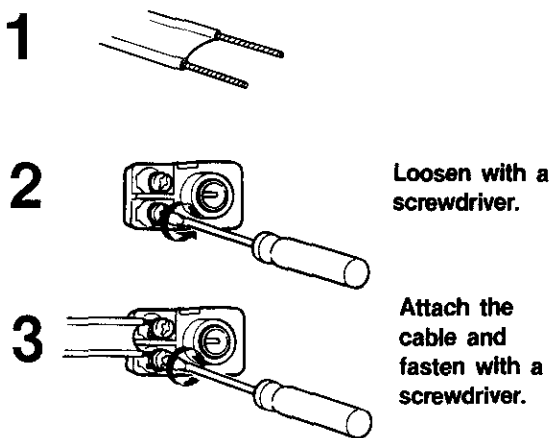

- 2** Plug the connector into VHF/UHF on the rear of the TV.

75-ohm coaxial cable (round)

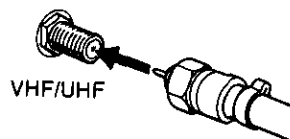

300-ohm twin-lead cable (flat)

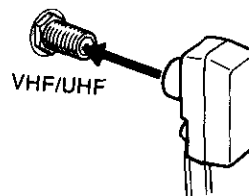

* Most combination antennas are equipped with a signal splitter. Remove the splitter and attach the appropriate connector.

When you connect both VHF and UHF antennas

Use the optional EAC-66 U/V mixer.

- 1** Prepare the VHF antenna end using the appropriate connector.
- 2** Connect the cables to the mixer.
- 3** Plug the mixer to VHF/UHF.

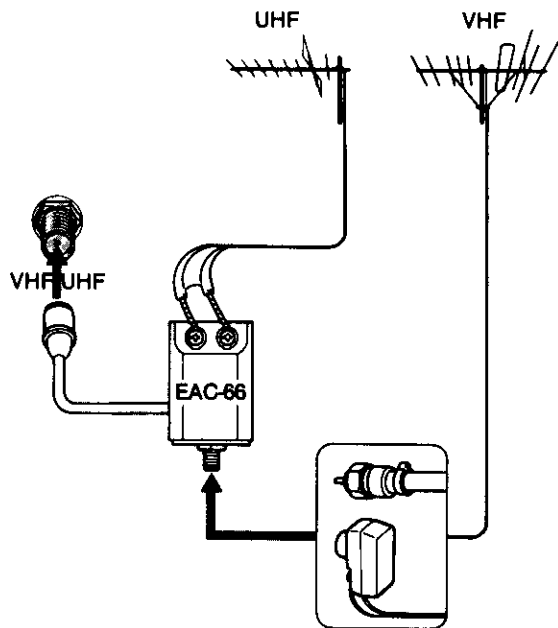

When you connect a cable with a special converter/decoder* for pay cable TV systems

Pay cable TV systems use scrambled or encoded signals and require special converters (decoders) in addition to the normal cable connection.

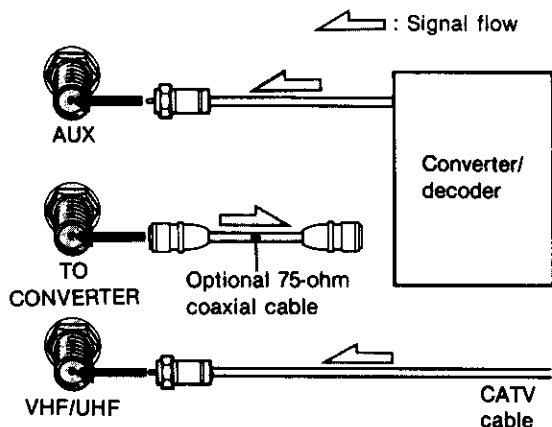

When you connect both VHF/UHF antennas and a CATV cable

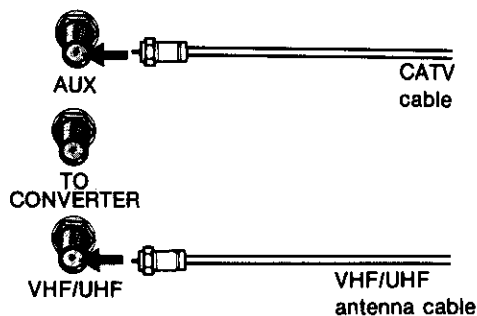

Note

In this case, do not connect anything to the TO CONVERTER terminal.

When the U/V mixer is used

Snow and noise may appear in the pictures of the cable TV channels over 37 (W + 1).

*The special converter/decoder will be supplied by the cable system operator.

Connecting Other Equipment

Connecting a VCR

With this connection, you will be able to...

- View the playback of video tapes
- Record TV programs
- Record a TV program while viewing another

1

Connecting VCRs with an S video output jack

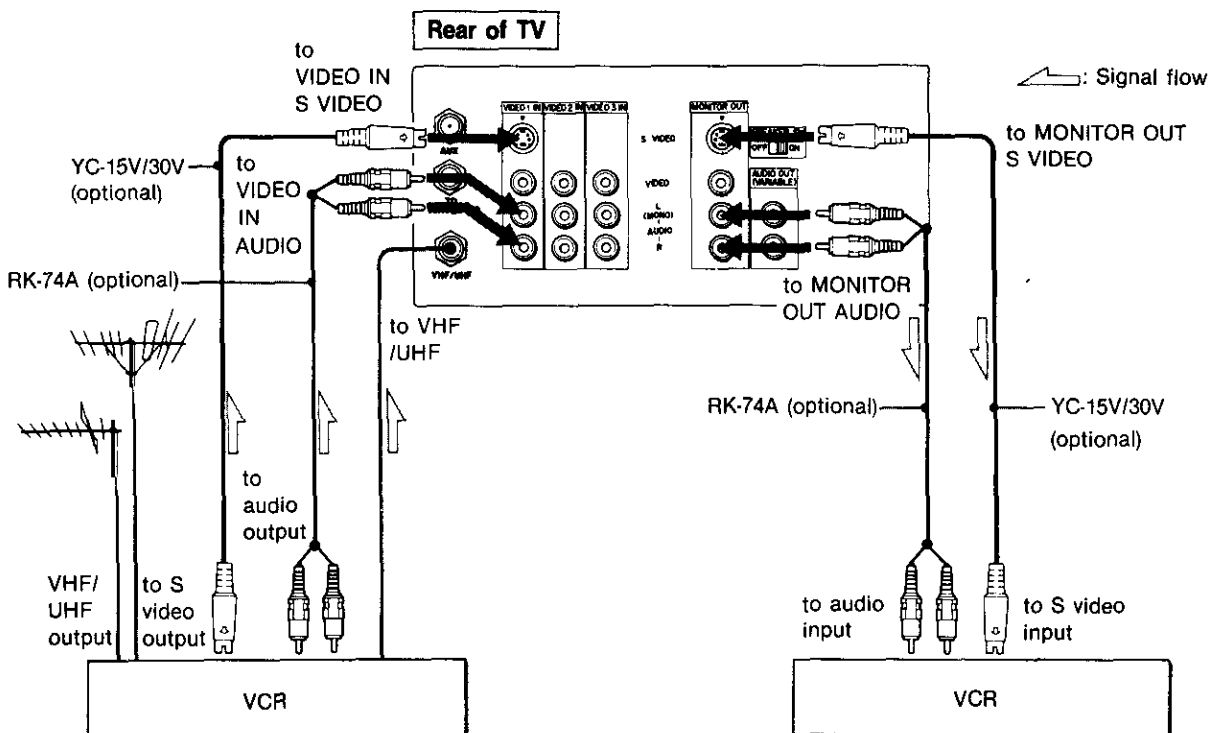

Note: The signal input to VIDEO IN cannot be output from S VIDEO OUT.
The signal input to S VIDEO IN can only be output from S VIDEO OUT.

Notes

- If you connect a monaural VCR, connect the audio output of the VCR to the L (MONO) jack of VIDEO 1/2/3 IN of the TV. The monaural sound will be heard from both speakers.
- For operation, refer to the instruction manual furnished with the VCR.
- The signal input to S VIDEO IN can only be output from S VIDEO OUT.
- Keep the VCR away from the TV if the picture or sound is affected.

About S video input

Video input and output signals can be separated into Y (luminance or brightness) and C (chroma or color) signals. Usually these two signals are combined in a VCR and sent as one signal to a TV. Separation of the Y and C signals prevents them from interfering with one another, thereby improving picture (especially in color) quality. This unit is equipped with an S video input jack through which these separated signal can be input directly.

2

Connecting VCRs/video disc players, etc. not equipped with an S video output jack

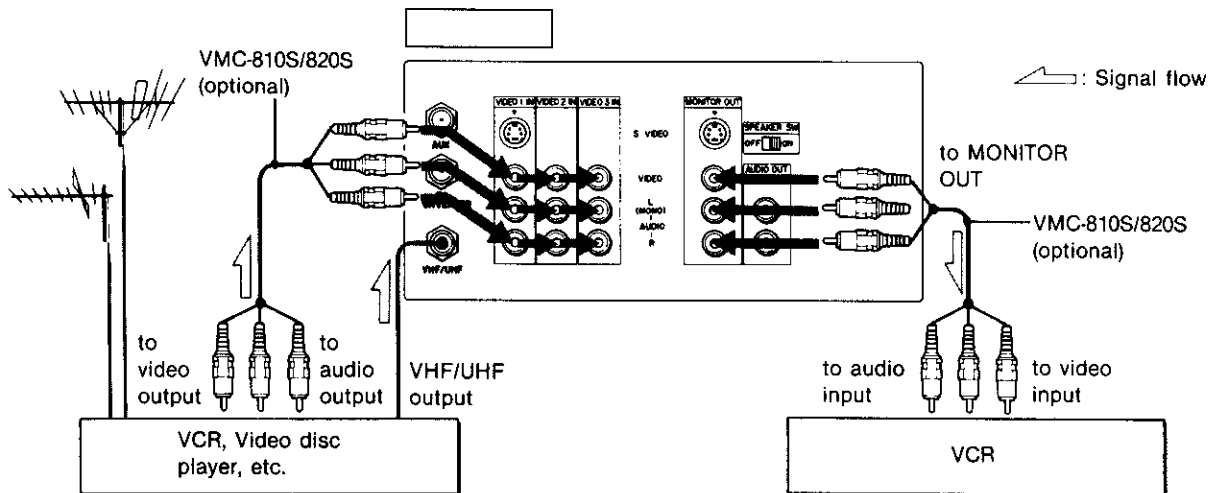

Preparations

- 1 Turn on the TV.
- 2 Press the TV/VIDEO button on the TV or an input select button on the commander so that the "VIDEO 1", "VIDEO 2" or "VIDEO 3" indication appears on the screen.
 VIDEO 1: for equipment connected to VIDEO 1 IN
 VIDEO 2: for equipment connected to VIDEO 2 IN
 VIDEO 3: for equipment connected to VIDEO 3 IN

Operation

When using a Sony infrared remote control VCR, video disc player or multi disc player, the equipment can be operated with the supplied Remote Commander.

- 1 Set the VTR1-2-3-MDP selector to the desired position according to the equipment to be operated.
 VTR 1: Sony Betamax VCR
 VTR 2: Sony 8 mm VCR
 VTR 3: Sony VHS VCR
 MDP: Sony Video disc player or multi disc player
- 2 Press the VCR/multi disc player operation button on the commander.

To return to the TV mode

- Press the TV/VIDEO button on the TV so that a channel number appears on the screen.
- Press the TV button on the Remote Commander.

To view one TV program while recording another
 Press the TV/VTR mode select button on the VCR or commander so that the VCR will be in the TV mode. Press the TV button on the commander, and select the channel you want to view.

When you cannot obtain a clear picture and/or sound
 Make sure that the TV/VTR mode select button on the VCR is set to TV. Re-select the desired channel with the buttons on the TV or the Remote Commander.

Connecting an Audio System

—To listen to the TV or connected VCR sound through an audio system

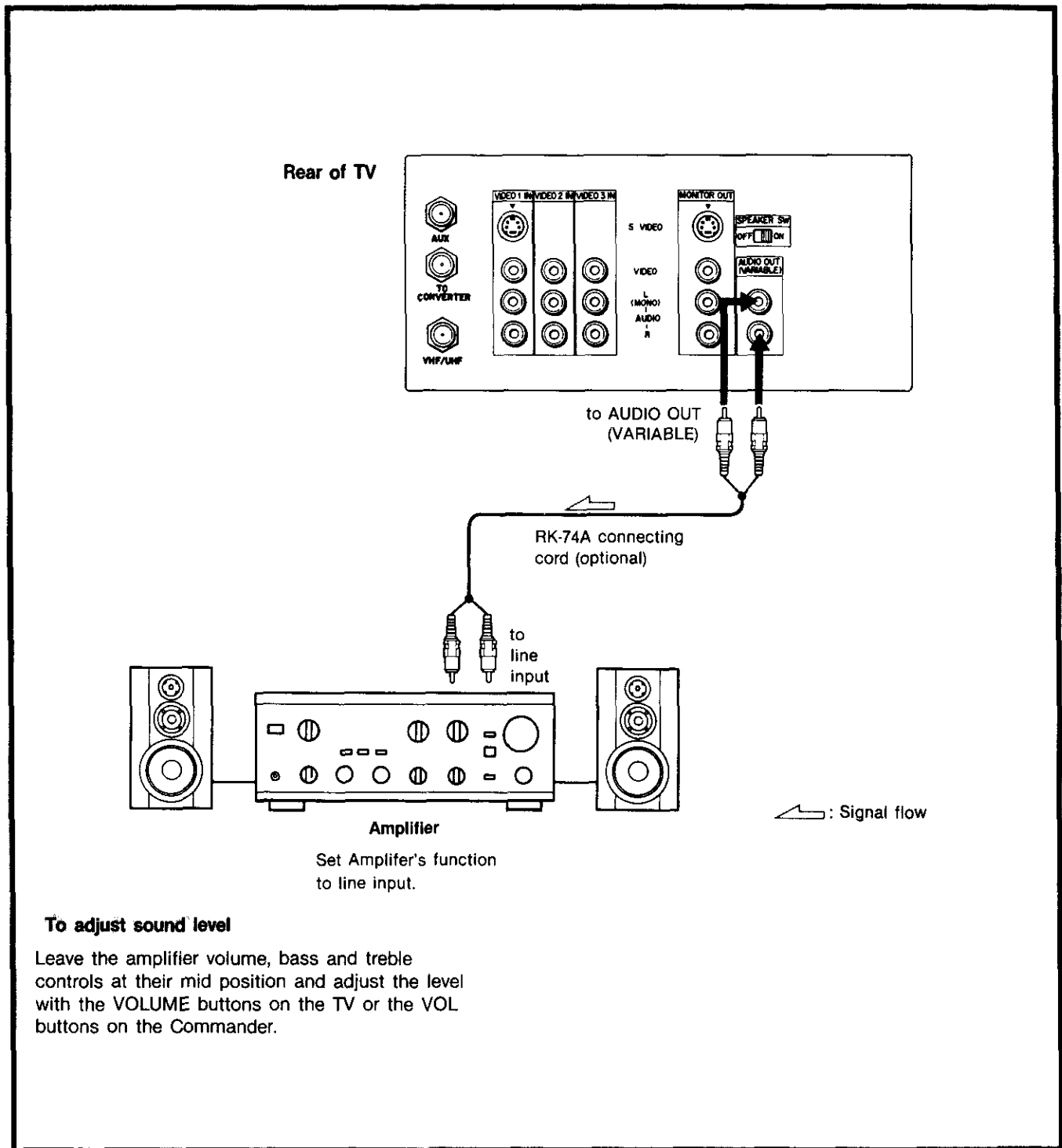

When an audio system is connected to AUDIO OUT, be sure to set the SPEAKER SW (switch) on the TV to OFF. The sound from the TV's speakers will be cut off.

For better sound
We recommend that you use the optional video rack (see page 31).



Presetting TV Channels

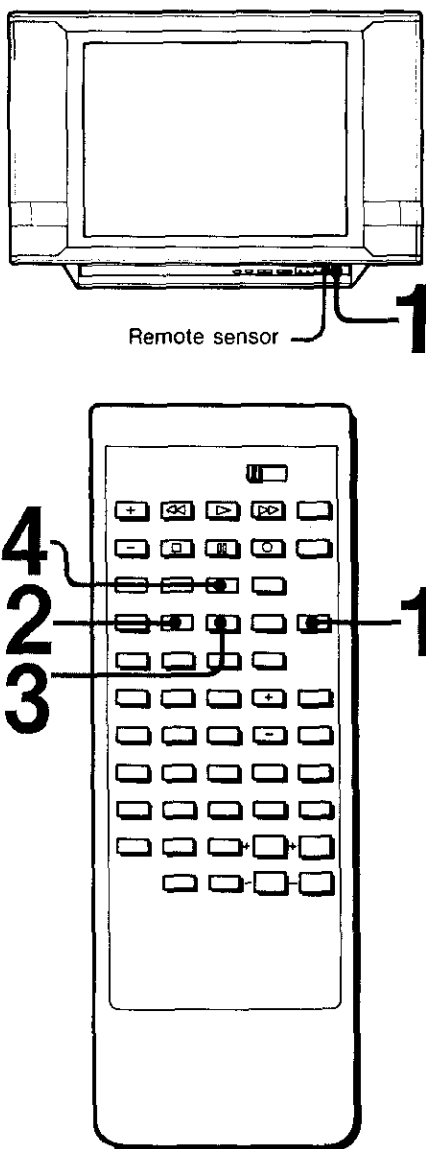

1 Press **POWER** on the TV or the Remote Commander to turn the TV on.

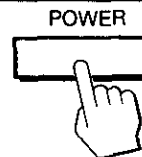

2 Press **CABLE** so that the appropriate mode appears.

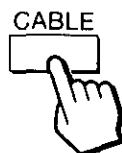

To preset VHF or UHF channels

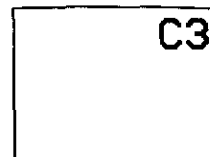

To preset cable TV channels

3 Press **ANT/AUX** according to the channel to be preset.

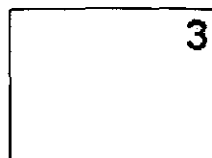

To preset VHF, UHF or regular cable TV channels

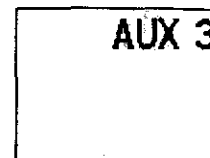

To preset pay cable TV channels

4 Press **AUTO PGM.**



"AUTO PROGRAM" is displayed on the screen and receivable channels (other than the channels already preset) will be preset in numerical sequence. The channels previously preset remain in the unit's memory.

When no more channels can be found, the programming stops and the lowest numbered channel is displayed.

Receivable channels of this TV are:

VHF: 2-13
UHF: 14-69
Cable: 1-125

To add the channels that could not be preset with automatic programming because their signal strength was too weak, or to erase unnecessary channels.

Follow the steps in "To preset only the desired channels or to erase unnecessary channels" on the next page.

To check preset channels

Press CH +/-.

If the indication "VIDEO 1, VIDEO 2, VIDEO 3" is displayed on the screen

Press the TV/VIDEO button on the TV, or the TV button on the Remote Commander so that a channel number appears.

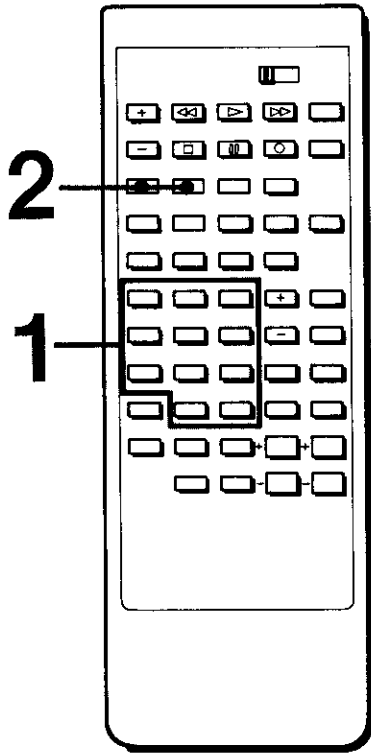

1 Press the channel number button(s) and then ENTER to select the channel to be added or erased.

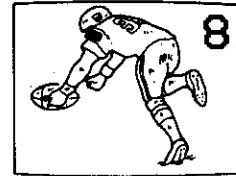
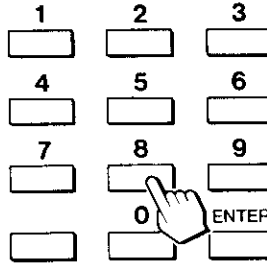

2 To add channels — Press ADD.

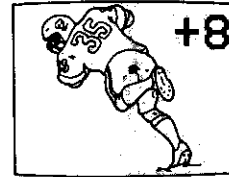

A "+" appears for a moment.
This channel has now been added to the channel scan memory.

To erase channels — Press ERASE.



A "-" appears for a moment.
This channel has now been erased from the channel scan memory.
The next time the CH +/- button is pressed, this channel will be skipped.

Repeat steps 1 and 2 for other channels to be added or erased.

When a VHF or UHF channel is erased

The cable TV channel with the same number is also erased and vice versa.

Cable TV channel chart*

Cable TV systems use letters or numbers to designate channels. To tune in a channel, refer to the chart below.

Number on this TV	1	5	6	14	15	16	17	18	19	20	21	22	23	24	25	26	27	28	29	30		
Corresponding CATV channel	A-8	A-7	A-6	A	B	C	D	E	F	G	H	I	J	K	L	M	N	O	P	Q		
	31	32	33	34	35	36	37	38	39	93	94	95	96	97	98	99	100	101	102	123	124	125
	R	S	T	U	V	W	W+1	W+2	W+3	W+57	W+58	A-5	A-4	A-3	A-2	A-1	W+59	W+60	W+61	W+82	W+83	W+84

Check with your local cable TV company for more complete information on the available channels.

*The designation of the cable TV channels conforms to the EIA/NCTA recommendation.

Watching TV Programs

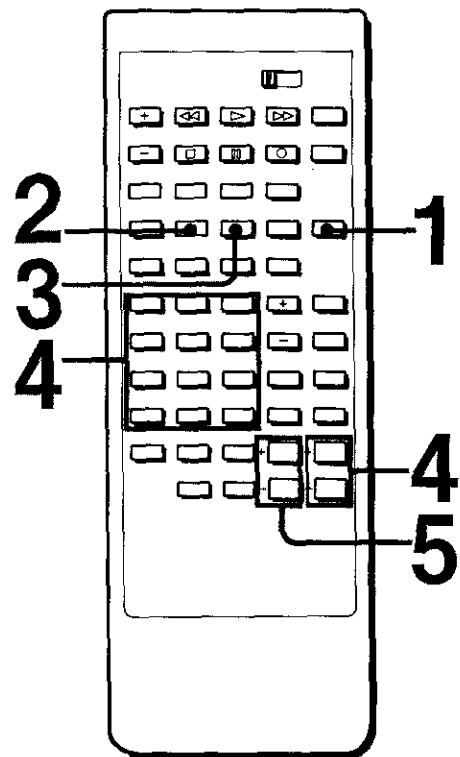
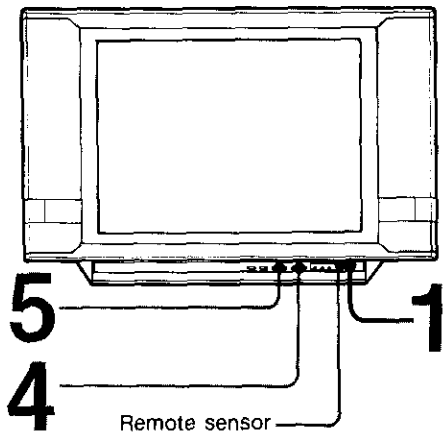

1 Press **POWER** on the TV or the Remote Commander to turn the TV on.

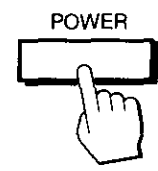

2 Press **CABLE** so that the appropriate mode appears.

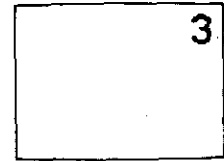
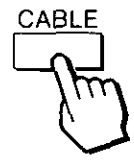

To view VHF or UHF channels

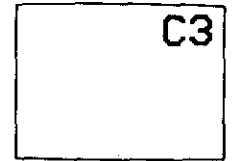

To view cable TV channels

3 Press **ANT/AUX** according to the channel to be watched.

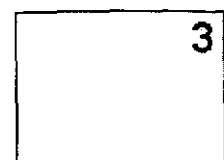

To view VHF, UHF or regular cable TV channels

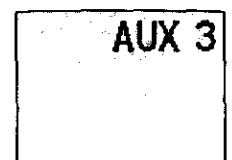

To view pay cable TV channels

4 Select a channel in one of the following two ways:

To scan the preset channels in numerical sequence, press CH +/-.

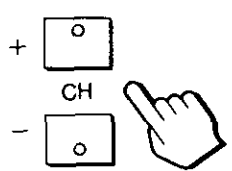

To select a channel directly, press the channel number button(s) and then ENTER. For example, to select channel 10, press 1,0 and ENTER.

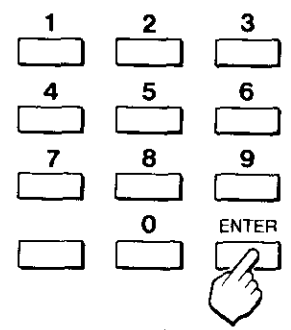

5 Press **VOL +** or **-** to adjust the volume.

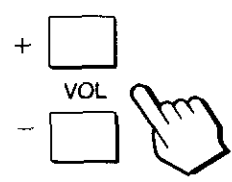

Notes

To turn off the unit

Press POWER on the TV or the Remote Commander again.

If the indication "VIDEO 1, VIDEO 2, VIDEO 3" is displayed on the screen

Press the TV/VIDEO button on the TV or the TV button on the Remote Commander so that a channel number appears.

Enjoying Convenient Features

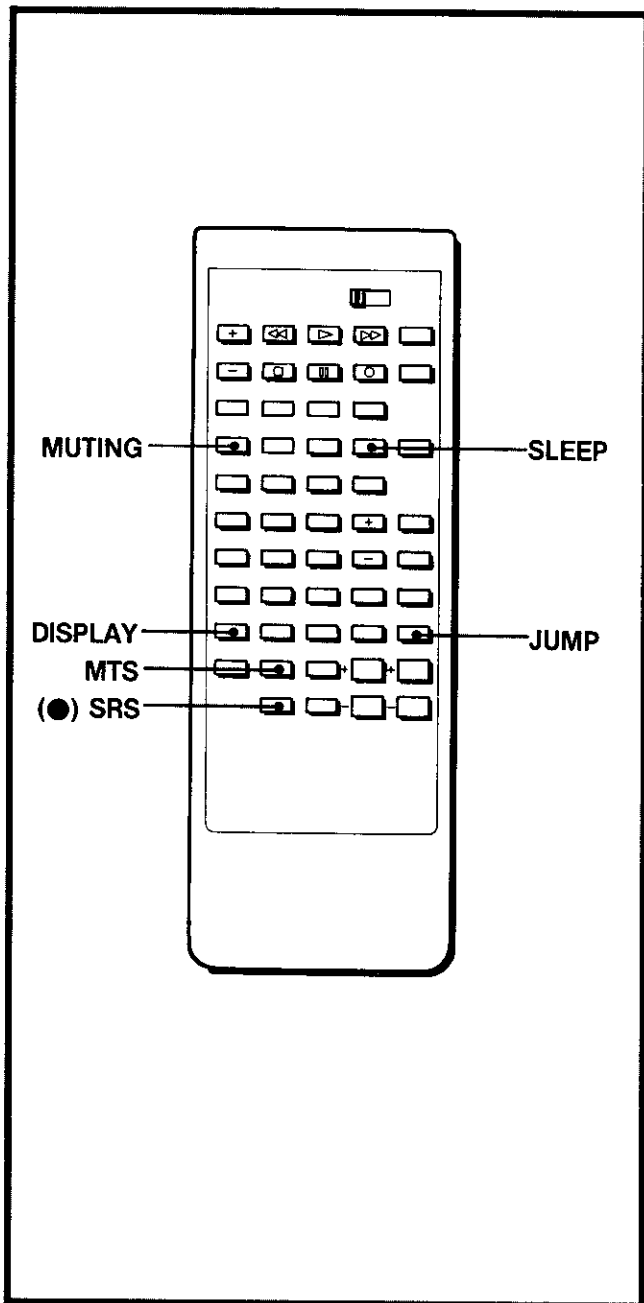

Receiving a Multichannel TV Sound program

Each time **MTS** is pressed, **MAIN**, **SAP** (Second Audio Program), or **MONO** are selected in sequence.

To listen to stereo sound, select the **MAIN** mode so that the on-screen **MAIN** indication appears. The **STEREO** indicator on the TV lights up whenever a stereo broadcast is received.

When the reception of the stereo sound is noisy, select the **MONO** mode. The reception will be easy at the sacrifice of the stereo effect.

Muting the sound

Press **MUTING**. The "MUTING" indication will appear on the screen. To restore the sound, press **MUTING** again or **VOL +**.

Keeping the channel displayed

Press **DISPLAY**. To make the channel display disappear, press **DISPLAY** again.

Using the SLEEP timer

Press **SLEEP**. The TV will be turned off automatically after about 1 hour. The "SLEEP" indication will appear on the screen for a few seconds and the **SLEEP** indicator on the TV will remain lit until the TV is turned off. To cancel the **SLEEP** timer, press **SLEEP** again so that the **SLEEP** indicator goes out, or turn off the TV.

Switching quickly between two channels

Press **JUMP**. Each time **JUMP** is pressed, the channel which appeared on the screen directly before is recalled. This button enables you to keep track of two programs alternately.

JUMP also switches programs in the **ANT/AUX** mode.

For more natural sound reproduction

Press **SRS** (sound retrieval system). The "(●) **SRS**" indication will appear on the screen. To cancel **SRS**, press **SRS** again.

Adjusting the Picture and Sound

You can adjust the picture and sound levels and have the unit store them for each input mode (TV/VIDEO 1/2/3).

Buttons used for adjustment

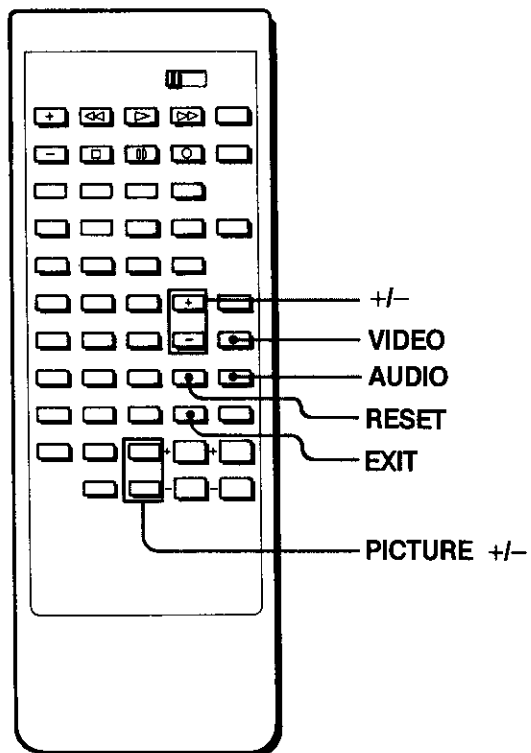

For operation, see the next pages.

Adjusting the Picture Press VIDEO repeatedly until the on-screen display of the item to be adjusted appears.

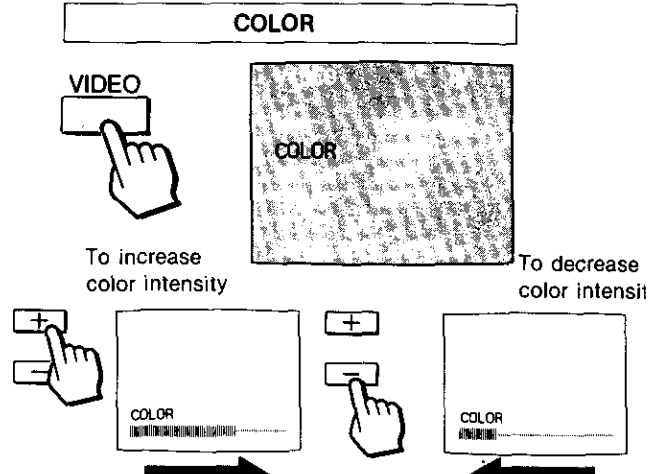
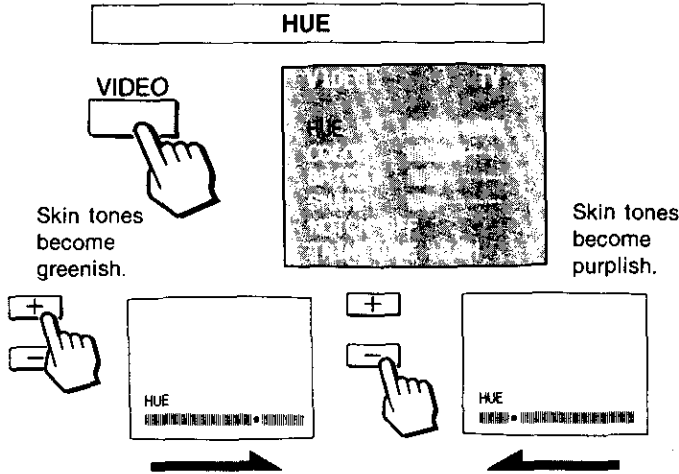

To adjust picture contrast

Press to increase picture contrast with vivid color

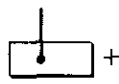

PICTURE

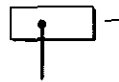

Press to decrease picture contrast with soft color

The picture contrast level cannot be memorized under each input mode.

To restore the factory preset levels

Press RESET.
The adjustment levels will be cleared at once.

To restore the normal picture

Press EXIT.

*** TRINITONE adjustment**

Usually color picture tubes are manufactured with a fixed color temperature (tint) that determines the "warmness (reddish)" or "coolness (bluish)" of the picture it produces. With Sony's Trinitone feature, you can adjust the color of the picture to your preference.

TRINITONE LOW
A touch of red will be added to the white part of the picture.

↔ **TRINITONE HIGH**
The factory preset whiteness level will be restored.

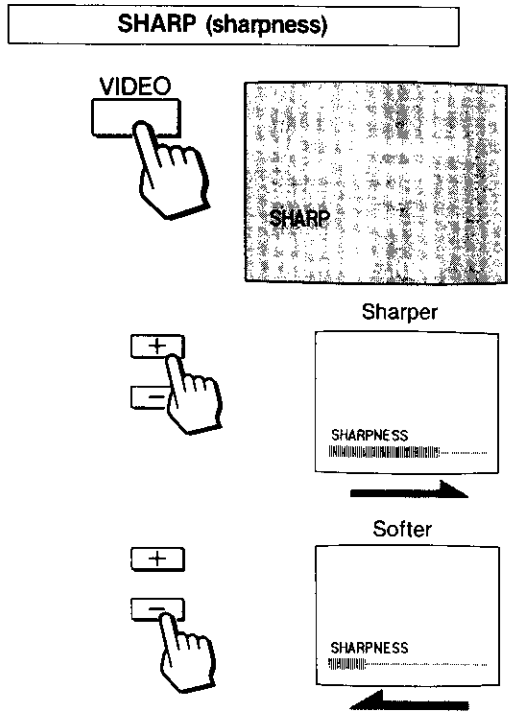
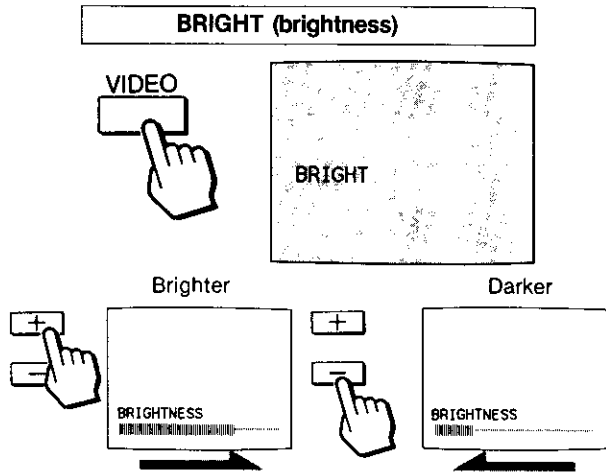

NOTCH filter setting
 Normally, set to NOTCH OFF.
 If dots or stripes appear while you are watching a picture from a computer or a video source, set to NOTCH ON.

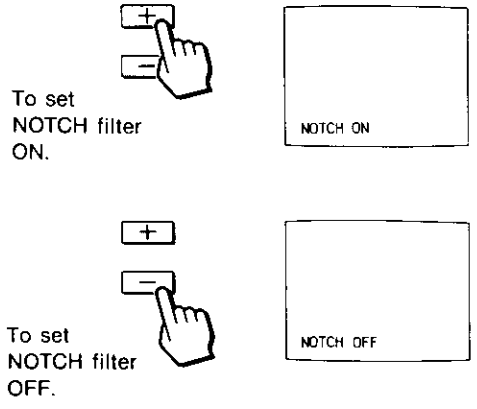
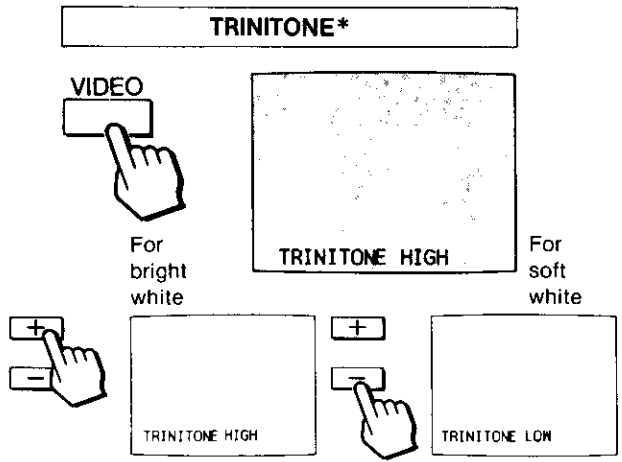
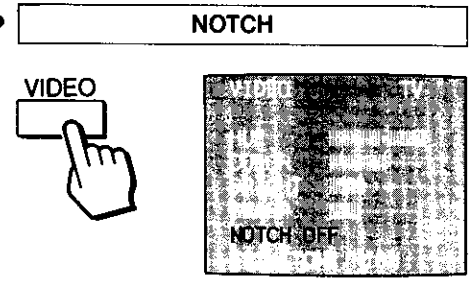

Adjusting the Sound

Press AUDIO repeatedly until the on-screen display of the item to be adjusted appears.

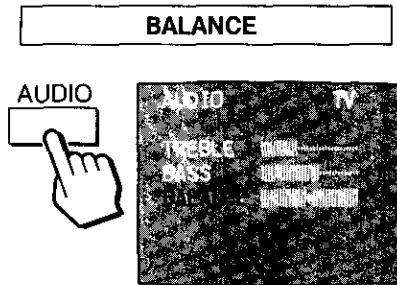
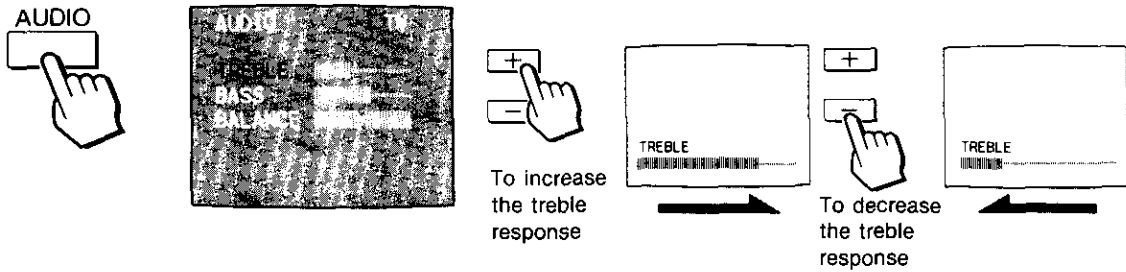

To restore the factory preset levels
Press RESET.
The adjustment levels will be cleared at once.

To restore the normal picture
Press EXIT.



Using the GUIDE Function

The GUIDE function calls up the on-screen menu and instructions on how to set the current time, timer, channel block.

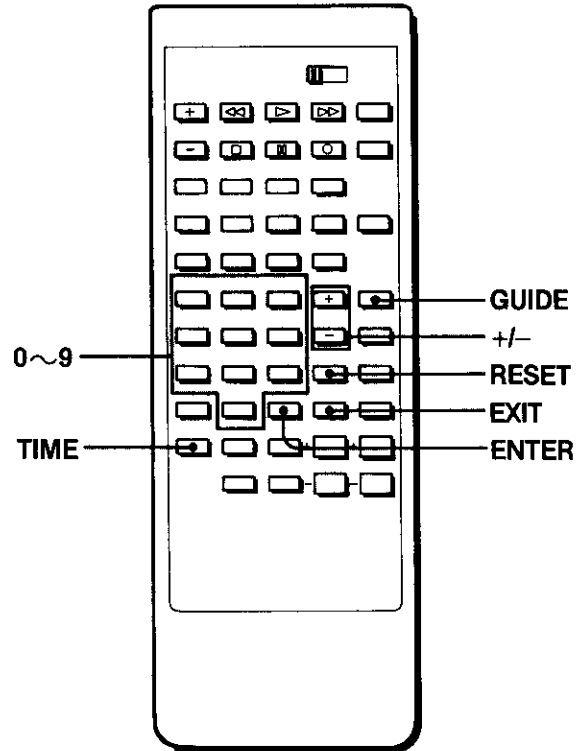

Buttons used for GUIDE function



- All setting will be erased from the unit's memory if the unit is unplugged, or if a power failure occurs.
- The ON/OFF TIMER and CHANNEL BLOCK will operate only if the clock is set correctly.

Setting the Clock

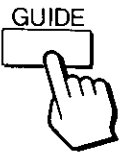
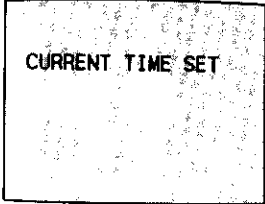
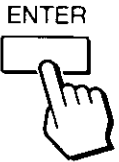
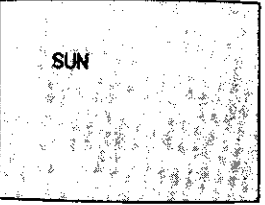
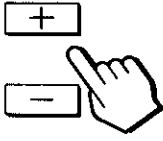
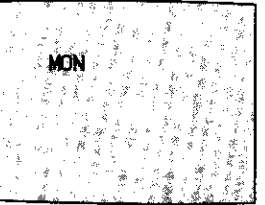
Example: To set the clock to 5:30 PM, Monday.

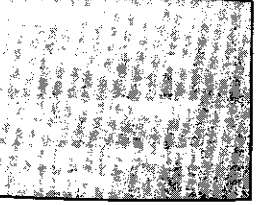
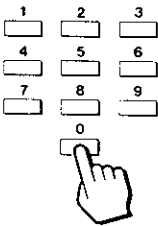
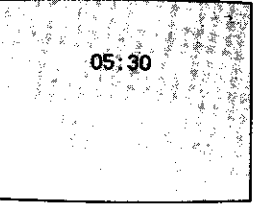
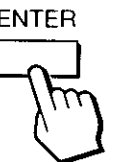
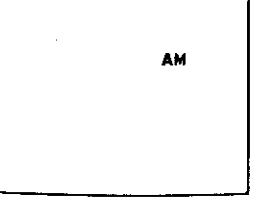
<p>1 Press GUIDE. Press repeatedly until "CURRENT TIME SET" turns red.</p>		
<p>2 Press ENTER.</p>		
<p>3 Press +/- until the desired day of the week appears.</p>		
<p>4 Press ENTER. If the time is already set, the current set time will appear. To clear these numbers, press any number.</p>		
<p>5 Press 0-9 to set the desired time. (For 5:30, press 0,5,3,0)</p>		
<p>6 Press ENTER.</p>		

7

Press +/- to set AM or PM.

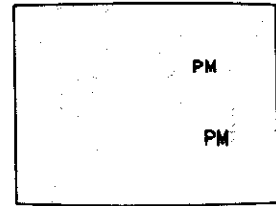
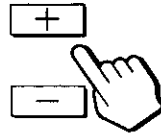

8

Press ENTER.

The moment ENTER is pressed, the clock will start.

Now, the clock is set. The indication will disappear after approx. 5 seconds.

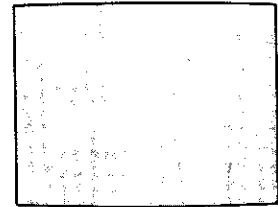
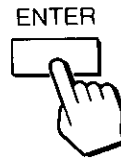

To restore the normal picture

Press EXIT.

To clear the current time setting

Display the "CURRENT TIME SET" page and press RESET, then EXIT.

To reset the setting

Display the "CURRENT TIME SET" page and press RESET, then repeat steps 3 to 8.

To display the current time

Press TIME.

Notes







- The internal clock of this TV operates on a 12-hour cycle. If a 24-hour cycle number is entered, it will be cleared when ENTER is pressed.

12:00 AM stands for midnight.
12:00 PM stands for noon.

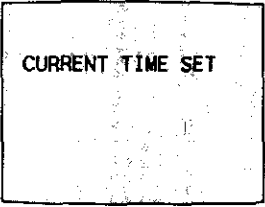
Setting the ON/OFF Timer

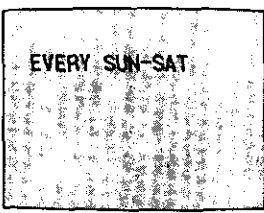
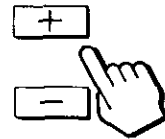
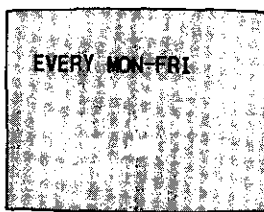
ON/OFF TIMER allows the program of your choice to appear on the screen at the desired time.

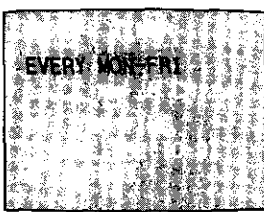
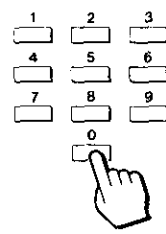
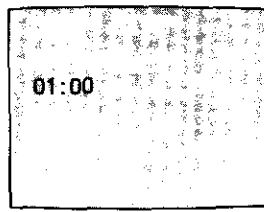
Example: Set the timer to turn on the TV to channel 8 at 1:00 PM for 3 hours every Monday through Friday.

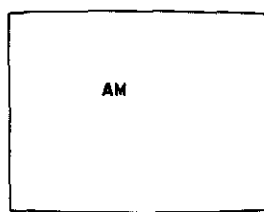
<p>1 Press GUIDE. Press repeatedly until "ON/OFF TIMER" turns red.</p>		
<p>2 Press ENTER. If the clock has not been set, "PLEASE SET CURRENT TIME FIRST" appears on the screen. Go back to page 26.</p>		
<p>3 Press +/- until the desired day of the week appears.</p>		
<p>4 Press ENTER.</p>		
<p>5 Press 0-9 to set the desired time. (For 1:00, press 0,1,0,0.)</p>		
<p>6 Press ENTER.</p>		

7

Press +/- to set AM or PM.

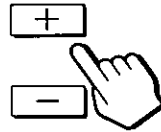

8

Press ENTER.

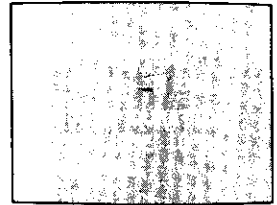
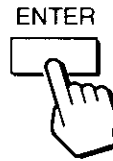

9

Press a number button to set the duration.
(Up to 9 hours can be set).

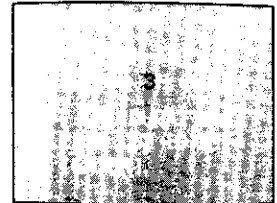
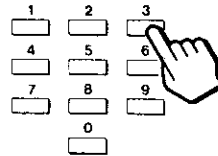

10

Press ENTER.

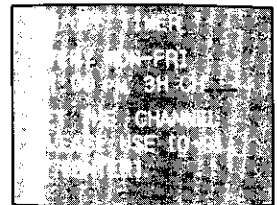

11

Press 0-9 to set the desired channel number.

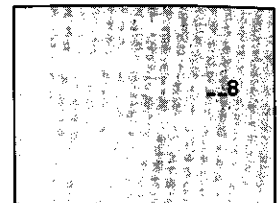
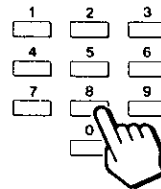

12

Press ENTER.
Now ON/OFF timer is set.
The TIMER indicator on the TV lights up.

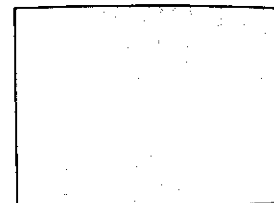

Setting the Channel Block

CHANNEL BLOCK prevents a channel from appearing on the screen for preset hours. We suggest you use this function to prevent children from watching undesirable programs.

Example: Set the CHANNEL BLOCK at 4:00 PM (for 1 hour), every Saturday, at channel 12.

- 1** **Press GUIDE.**
Press repeatedly until "CHANNEL BLOCK" turns red.

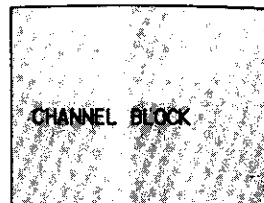

Step 2-11 Same as Setting the ON/OFF Timer.
(See page 28.)

- 12** **Press ENTER.**
Now CHANNEL BLOCK is set.
At the preset time, the picture of the selected channel will be blocked from view and the sound will be muted. A red "BLOCKED" indication will appear on the screen while the channel is blocked.

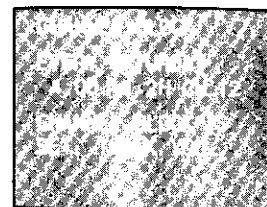

To restore the normal picture
Press EXIT.

To clear the setting
Display the "CHANNEL BLOCK" page and press RESET, then EXIT.

To reset the setting
Display the "CHANNEL BLOCK" page and repeat steps from the beginning.

Specifications

Television system	American TV standards
Channel coverage	VHF: 2–13 UHF: 14–69 Cable TV: 1–125
Picture tube	Microblack Trinitron tube 27-inch picture measured diagonally 28-inch picture tube measured diagonally (KV-27HSR10) 32-inch picture measured diagonally 34-inch picture tube measured diagonally (KV-32HSR10)
Antenna	75-ohm external antenna terminal for VHF/UHF
Input	VIDEO 1, 2 and 3 IN S VIDEO IN (4-pin mini DIN) Y: 1 Vp-p, 75-ohms unbalanced, sync negative C: 0.286 Vp-p (Burst signal), 75-ohms Video (phono jacks): 1 Vp-p, 75-ohms unbalanced, sync negative Audio (phono jacks): 500 mVrms (100% modulation) Impedance: 47 kilohms
Output	MONITOR OUTPUT S VIDEO OUTPUT (4-pin mini DIN) Y: 1 Vp-p, 75-ohms unbalanced, sync negative C: 0.286 Vp-p (Burst signal) 75-ohms Video (phono jacks): 1 Vp-p, 75-ohms unbalanced, sync negative Audio (phono jacks): 500 mVrms (100% modulation) Impedance: 10 kilohms AUDIO OUTPUT (VARIABLE) (phono jacks) More than 408 mVrms at the maximum volume setting (variable) Impedance: 5 kilohms

Power requirements	120V AC, 60Hz
Power consumption	KV-27HSR10 225W (max.) 1.5W (in standby condition) KV-32HSR10 240W (max.) 1.5W (in standby condition)

Accessories supplied

Remote Commander RM-763
with 2 size AA EVEREADY
batteries.
Antenna connector (1)



Optional accessories

U/V mixer EAC-66
Connecting cable
VMC-810/820S
YC-15V/30V
Video rack
SU-235X (with super-woofer)
SU-235X (with super-woofer)
SU-251 (black)
SU-330 (black)

Design and specifications are subject to change without notice.

Troubleshooting

Disturbances in picture and sound can often be eliminated by checking the symptoms and following the suggestions listed below.

SYMPTOM	CHECK AND ADJUST
<p>Poor or no picture (Screen not lit), good sound</p>	<ul style="list-style-type: none"> • Adjust PICTURE. • Adjust BRIGHT. • Check antenna/cable connections.
<p>Good picture, no sound</p>	<ul style="list-style-type: none"> • Press VOLUME + on the TV or VOL + on the Remote Commander. • Press MUTING on the Remote Commander. • Check that the MTS button is set correctly. • Check that the TV/VIDEO button is set correctly. • Set the SPEAKER SW (switch) to ON.
<p>No picture (screen not lit), no sound</p>	<ul style="list-style-type: none"> • Is POWER switched on? • Plug the unit into a wall outlet. • Check that the TV/VIDEO button is set correctly.
<p>No color</p>	<ul style="list-style-type: none"> • Is it a color program? • Adjust COLOR.
<p>Snow and noise only</p>	<ul style="list-style-type: none"> • Is it an active or the correct channel? • Check the CABLE setting. • Check the ANT/AUX button setting. • Check antenna/cable connections.
<div style="display: flex; align-items: center;">  <div style="font-size: small;"> <p>Dotted lines or stripes</p> </div> </div>	<p>This is often caused by local interference. (e.g. cars, neon signs, hairdryers etc.) Adjust antenna for minimum interference.</p>
<div style="display: flex; align-items: center;">  <div style="font-size: small;"> <p>Double images or ghosts</p> </div> </div>	<p>Reflections from nearby mountains or buildings often cause this problem. A highly directional outdoor antenna or a CATV cable may improve the picture.</p>
<p>Try another channel. It could be station trouble.</p>	

If the problem persists, contact your nearest service facility.