

# SEARS

## operator's manual

MODEL NO. 143.999011

SOLID STATE IGNITION

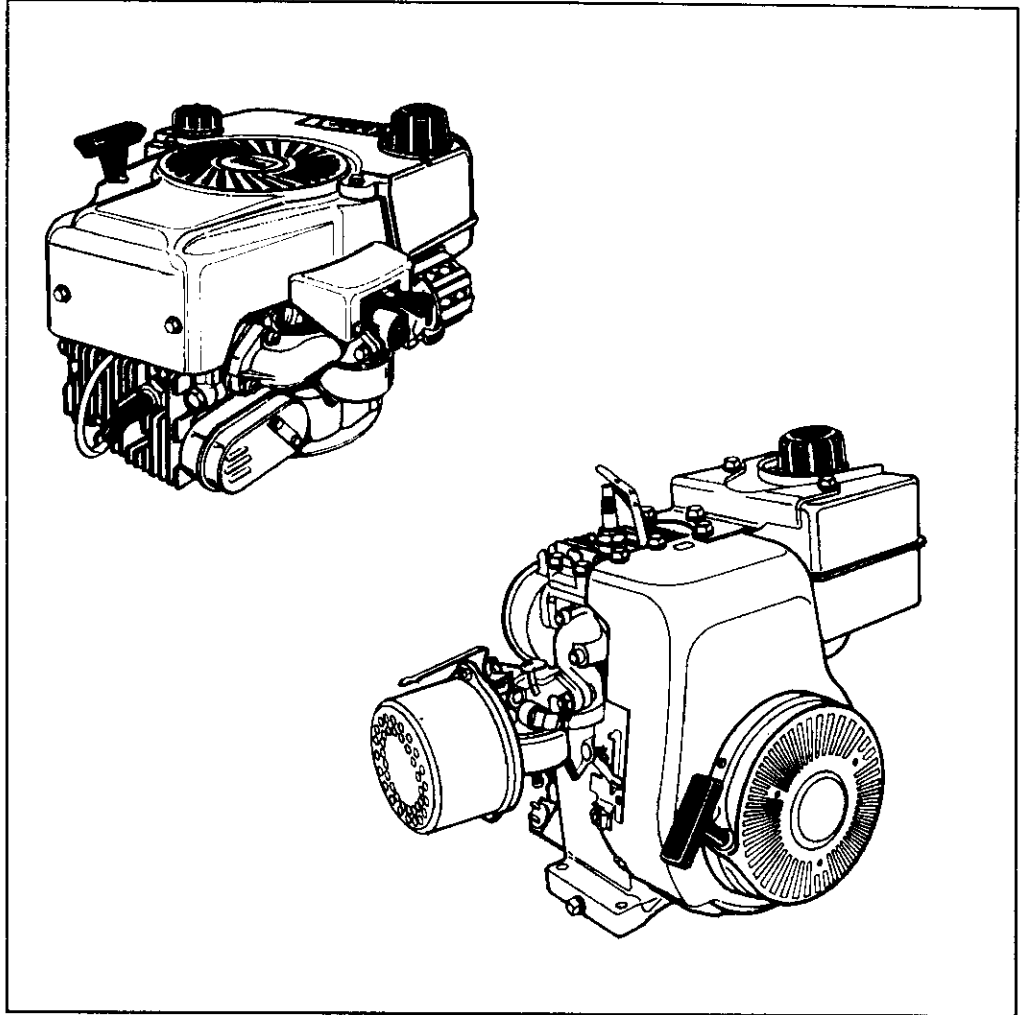

LIBRARY:

Received

10/19/99 ccc

Checked

10/19/99 ccc

Entered

LIS

MRPDS

Received

OCT 20 1999

# ENGINE

**CAUTION:**  
Read **RULES** for  
Safe **OPERATION**  
and **INSTRUCTIONS**  
Carefully

- Operating
- Maintenance
- Repair Parts



California Proposition 65 **WARNING:** The engine exhaust from this product contains chemicals known to the State of California to cause cancer, birth defects or other reproductive harm.

Sold by SEARS, ROEBUCK AND CO., CHICAGO, IL 60684 U.S.A.  
and SEARS CANADA, INC., TORONTO, ONTARIO, CANADA

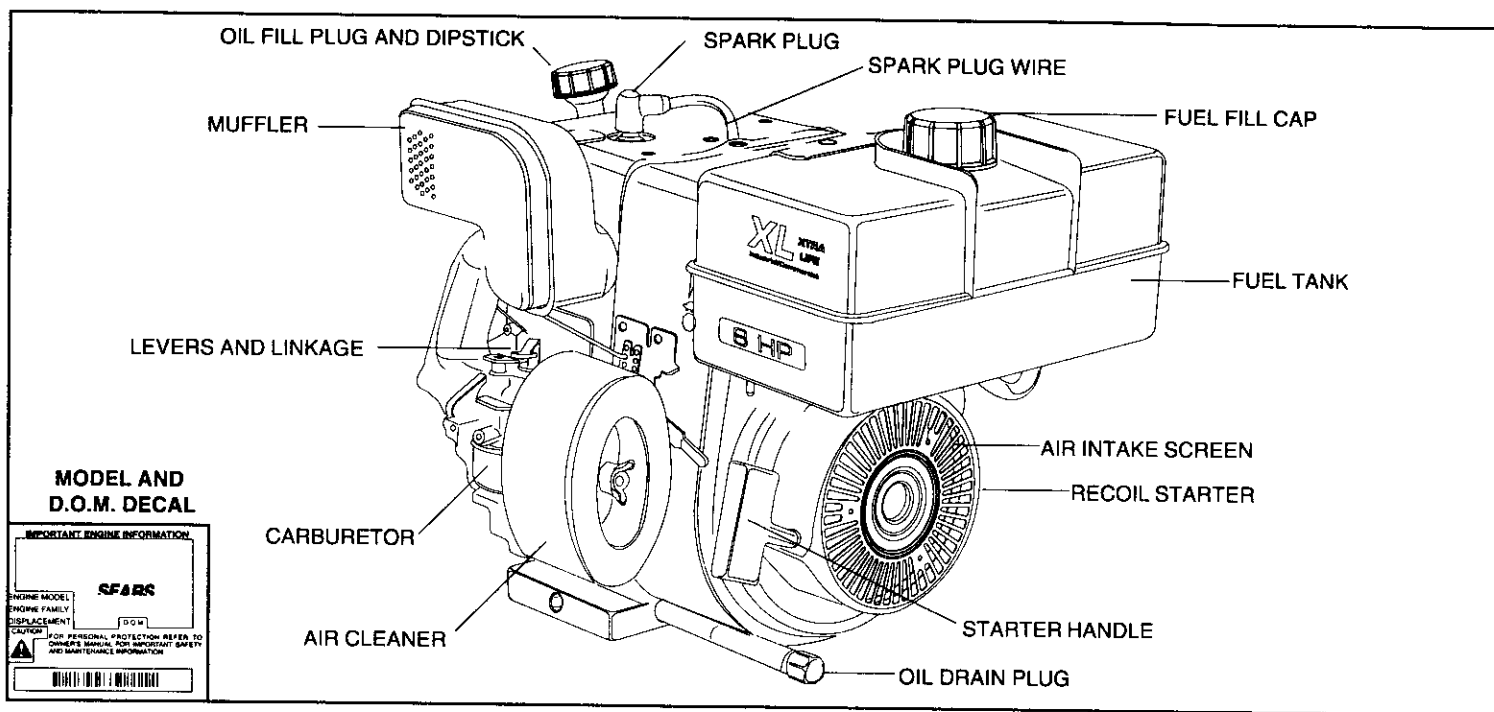

Figure 1



**THIS SYMBOL POINTS OUT IMPORTANT SAFETY INSTRUCTIONS WHICH IF NOT FOLLOWED COULD ENDANGER THE PERSONAL SAFETY AND/OR PROPERTY OF YOURSELF AND OTHERS. READ AND FOLLOW ALL INSTRUCTIONS IN THIS MANUAL AND ANY PROVIDED WITH THE EQUIPMENT ON WHICH THIS ENGINE IS USED BEFORE ATTEMPTING TO OPERATING.**



**THESE SYMBOLS MAY APPEAR ON THE ENGINE:**



**FAST**



**SLOW**



**STOP**



**OFF**



**CHOCKE**



**FULL**

**ENGINES WHICH ARE CERTIFIED TO COMPLY WITH CALIFORNIA AND US EPA EMISSION REGULATIONS FOR ULGE ENGINES:** Are certified to operate on regular unleaded gasoline. Include the following emission control system(s): EM, TWC (if so equipped); Do not include any user adjustable features - therefore no other adjustments are needed.

## OIL & FUEL RECOMMENDATIONS

TO OPERATE ENGINE, YOU WILL NEED THE FOLLOWING:

- ① Be sure original container is marked:  
A.P.I. service "SF"- "SJ".  
**FOR SUMMER (ABOVE 32°F; 0°C) USE SAE 30 OIL.**  
Using multigrade oil will increase oil consumption.  
**FOR WINTER (BELOW 32°F; 0°C) USE SAE 5W30 OIL.**  
(SAE 10W is an acceptable substitute.)  
**DO NOT USE SAE 10W40 OIL.**  
**OIL SUMP CAPACITY:** 24 ounces (1-1/2 pints)  
.71 liter
- ② **A FRESH, CLEAN, UNLEADED REGULAR, UNLEADED PREMIUM, OR REFORMULATED AUTOMOTIVE GASOLINE ONLY. DO NOT USE LEADED GASOLINE.**  
**NOTE:** DO NOT USE GASOLINE CONTAINING METHANOL (WOOD ALCOHOL). Gasoline containing up to 10% ethanol or grain alcohol ("Gasohol"), or up to 15% MTBE (Methyl Tertiary Butyl Ether), may be used but requires special care when engine is unused for extended periods.  
See "STORAGE" instruction on Page 4.  
**NOTE:** Use clean oil and fuel and store in approved, clean covered containers. Use clean fill funnels.  
Never use "stale" gasoline left over from last season or stored for long periods.

## IMPORTANT

**KEEP THIS MANUAL HANDY AT ALL TIMES FOR FUTURE REFERENCE. READ IT CAREFULLY AND FAMILIARIZE YOURSELF WITH THE OPERATING, MAINTENANCE AND SAFETY INSTRUCTIONS. THIS MANUAL ALSO CONTAINS A COMPLETE PARTS LISTING.**

## BEFORE STARTING

- ① READ ALL INSTRUCTIONS PROVIDED WITH THE EQUIPMENT ON WHICH THIS ENGINE IS USED.
- ② **CHECK OIL LEVEL:**  
**CAUTION: NEVER RUN ENGINE UNLESS OIL LEVEL IS BETWEEN "FULL" AND "ADD" MARKS ON DIPSTICK.**  
**CHECK OIL LEVEL OFTEN DURING ENGINE BREAK-IN.**  
**NEVER RUN ENGINE UNLESS OIL FILL PLUG IS TIGHTENED SECURELY INTO OIL FILL HOLE.**
  - A. POSITION EQUIPMENT SO ENGINE IS LEVEL.
  - B. Clean area around oil fill plug (see Figure 1).
  - C. Remove oil fill plug and dipstick.
  - D. Wipe dipstick clean, insert it into oil fill hole and tighten securely.
  - E. Remove oil fill plug and check oil level. If level is not up to "FULL" mark on dipstick, add recommended oil, until it is. **POUR SLOWLY.**  
Wipe dipstick clean each time oil level is checked.  
**DO NOT FILL ABOVE "FULL" MARK ON DIPSTICK.**
  - F. Replace oil fill plug and tighten securely.  
See "MAINTENANCE" section for any future oil level and oil change instructions (see Page 3).

## BEFORE STARTING (Continued)

- ③ **FILL FUEL TANK** with gasoline as specified in the preceding "OIL & FUEL RECOMMENDATIONS" item 2.

### NEVER MIX OIL WITH GASOLINE

Never use "stale" gasoline left over from last season or stored for long periods.

**NEVER FILL FUEL TANK INDOORS. NEVER FILL FUEL TANK WHEN ENGINE IS RUNNING OR HOT. DO NOT SMOKE WHEN FILLING FUEL TANK.**

**NEVER FILL FUEL TANK COMPLETELY. FILL TANK TO 1/2" BELOW BOTTOM OF FILLER NECK TO PROVIDE SPACE FOR FUEL EXPANSION. WIPE ANY FUEL SPILLAGE FROM ENGINE AND EQUIPMENT BEFORE STARTING ENGINE.**

**ANY LIQUEFIED PETROLEUM (LPG) OR NATURAL GAS FUEL SYSTEM MUST BE LEAKPROOF AND MEET ALL APPLICABLE CODES AND REGULATIONS.**

## ④ CHECK THE FOLLOWING:

**A. BE SURE EQUIPMENT IS IN NEUTRAL GEAR WITH CLUTCHES, BELTS, CHAINS AND SAFETY SWITCHES DISENGAGED. (FOLLOW EQUIPMENT MANUFACTURER'S INSTRUCTIONS.) THIS SHOULD PLACE ANY SAFETY SWITCHES IN SAFE STARTING POSITION.**

B. Be sure spark plug wire is attached to spark plug (see Figure 1).

C. Be sure stop switch (see Figure 1) next to spark plug is not contacting spark plug.

D. Be sure any ignition switch on engine or equipment is in ON, RUN or START position.

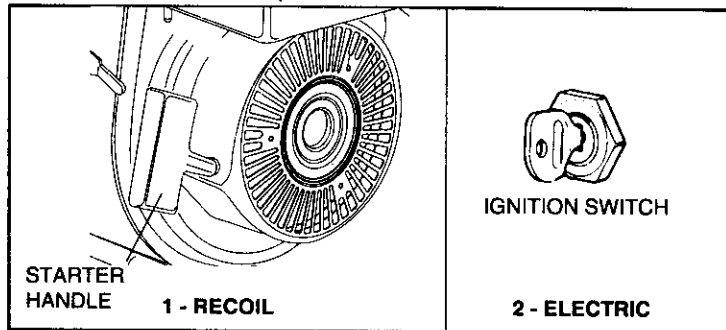

Figure 2

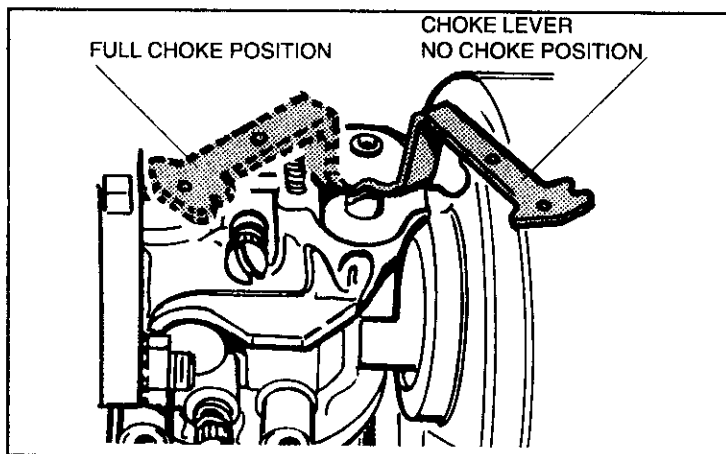

Figure 3

## STARTING

**NEVER RUN ENGINE INDOORS OR IN ENCLOSED, POORLY VENTILATED AREAS. ENGINE EXHAUST CONTAINS CARBON MONOXIDE, AN ODORLESS AND DEADLY GAS (CARBON MONOXIDE IS ALSO PRESENT IN ENGINE EXHAUST FROM LIQUID PETROLEUM (LPG) AND NATURAL GAS FUEL SYSTEMS).**

**KEEP HANDS, FEET, HAIR AND LOOSE CLOTHING AWAY FROM ANY MOVING PARTS ON ENGINE AND EQUIPMENT.**

**WARNING: TEMPERATURE OF MUFFLER AND NEARBY AREAS MAY EXCEED 150°F (65°C). AVOID THESE AREAS.**

## ① RECOIL STARTER (see Figures 2 and 3):

A. Move CHOKE LEVER to FULL CHOKE POSITION.

**NOTE: IF RESTARTING A WARM ENGINE AFTER A SHORT SHUTDOWN, MOVE CHOKE LEVER TO "NO CHOKE POSITION."**

B. Move EQUIPMENT CONTROL to START (see equipment manufacturer's instructions).

C. Grasp starter handle (see Figure 2) and pull rope out, slowly, until it pulls slightly harder. Let rope rewind slowly. Then pull rope with a rapid full arm stroke. Let rope rewind SLOWLY. Do not let starter handle snap back against starter.

D. Repeat instruction C until engine fires. When engine starts, move CHOKE LEVER to 1/2 CHOKE until engine runs smoothly and then to NO CHOKE POSITION.

If engine falters, move CHOKE LEVER to 1/2 CHOKE until engine runs smoothly and then to NO CHOKE POSITION.

**NOTE: If engine fires, but does not continue to run, move CHOKE LEVER to NO CHOKE POSITION and repeat instruction C until engine starts.**

If engine again fires, but does not continue to run, move CHOKE LEVER to FULL CHOKE POSITION and repeat instruction C and D until engine starts.

## ② ELECTRIC STARTER (see Figures 2 and 3):

A. Move CHOKE LEVER to FULL CHOKE POSITION.

**NOTE: IF RESTARTING A WARM ENGINE AFTER A SHORT SHUTDOWN, MOVE CHOKE LEVER TO "NO CHOKE POSITION."**

B. Move EQUIPMENT CONTROL to START (see equipment manufacturer's instructions).

C. Push starter button or turn ignition switch key (see equipment manufacturer's instructions) to crank engine.

D. Crank engine until it fires. When it starts, release starter button or ignition switch key and move choke lever to 1/2 CHOKE until engine runs smoothly and then to NO CHOKE POSITION.

If engine falters, move CHOKE LEVER to 1/2 CHOKE until engine runs smoothly and then to NO CHOKE POSITION.

**NOTE: If engine fires, but does not continue to run, move CHOKE LEVER to NO CHOKE POSITION and repeat instructions C and D until engine starts.**

## STOPPING

- 1 Move equipment control or any ignition stop switch on engine to STOP or OFF (see equipment manufacturer's instructions).
- 2 Push stop switch (see Figure 1) located next to spark plug on engine against spark plug and hold it in this position until engine is completely stopped.
- 3 **AFTER ENGINE IS STOPPED:**

**A. DISCONNECT SPARK PLUG WIRE FROM SPARK PLUG AND KEEP IT AWAY FROM SPARK PLUG.**

**B. TURN IGNITION SWITCH KEY (IF SO EQUIPPED) TO "OFF" POSITION AND REMOVE KEY FROM SWITCH. THIS WILL REDUCE THE POSSIBILITY OF UNAUTHORIZED STARTING OF ENGINE WHILE EQUIPMENT IS NOT IN USE.**

**NEVER STORE ENGINE WITH FUEL IN TANK INDOORS OR IN ENCLOSED, POORLY VENTILATED AREAS WHERE FUEL FUMES MAY REACH AN OPEN FLAME, SPARK OR PILOT LIGHT AS ON A FURNACE, WATER HEATER, CLOTHES DRYER OR OTHER GAS APPLIANCE.**

## MAINTENANCE

**WARNING: TEMPERATURE OF MUFFLER AND NEARBY AREAS MAY EXCEED 150°F (65°C). AVOID THESE AREAS.**

### 1 CHECK OIL LEVEL:

Check oil level every five (5) operating hours or each time engine is used. See "2 CHECK OIL LEVEL" in "BEFORE STARTING" on Page 1.

### 2 CHANGE OIL:

Change oil after first two (2) operating hours and every 25 operating hours thereafter, more often if operated in extremely dusty or dirty conditions. Change oil while engine is still warm from recent running.

- A. Position equipment so engine oil drain plug is lowest point on engine (see Figure 1).
- B. Remove oil drain plug and oil fill plug to drain oil.
- C. Replace oil drain plug and tighten securely.
- D. Fill oil sump with recommended oil. See "OIL & FUEL RECOMMENDATIONS" and "CHECK OIL LEVEL" on Page 1.
- E. Replace oil fill plug and tighten securely.
- F. Wipe up any spilled oil.

### 3 AIR CLEANER (see Figure 4):

**NEVER RUN ENGINE WITHOUT COMPLETE AIR CLEANER INSTALLED ON ENGINE.**

**A. TO SERVICE FILTER(S) (see Figure 4):**

#### 1. FOAM FILTER:

Clean and re-oil every three (3) months or every 25 operating hours. Clean and re-oil daily if used in extremely dusty conditions.

- a. Wash in water and detergent solution and squeeze (don't twist) until all dirt is removed.
- b. Rinse thoroughly in clear water.
- c. Wrap in a clean cloth and squeeze (don't twist) until completely dry.
- d. Saturate with engine oil and squeeze (don't twist) to distribute oil and remove excess oil.

#### 2. PAPER FILTER:

**DO NOT ATTEMPT TO CLEAN OR OIL FILTER.**

Replace once a year or every 100 operating hours, more often if used in extremely dusty conditions.

Replacement filters are available at any Sears Roebuck and Co. (or Sears Canada, Inc.) Service Center.

## MAINTENANCE (Continued)

### B. TO REMOVE AND INSTALL FILTER(S)

1. Remove wing nut and cover.
2. Slide foam filter off paper filter.
3. Inspect filters for discoloration or dirt accumulation. If either is present, service per preceding "TO SERVICE FILTER(S)" instructions.
4. Clean inside of base and cover thoroughly.
5. Install new paper filter on base.
6. Slide foam filter over paper filter.
7. Install cover and wing nut. Tighten wing nut securely.

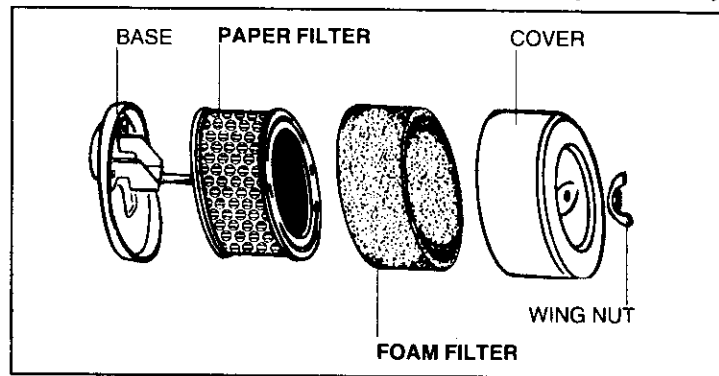

Figure 4

### 4 SPARK PLUG (see Figure 5):

This spark ignition system meets all requirements of the Canadian Interference-Causing Equipment Regulations. This engine complies with all current Australian and New Zealand limitations regarding electromagnetic interference. Check spark plug yearly or every 100 operating hours.

- A. Clean area around spark plug.
- B. Remove and inspect spark plug.
- C. Replace spark plug if electrodes are pitted, burned or porcelain is cracked. For replacement use Champion RJ17LM.  
**NOTE:** A resistor spark plug must be used for replacement.
- D. Check electrode gap with wire feeler gauge and set gap at .030 if necessary.
- E. Install spark plug, tighten securely.

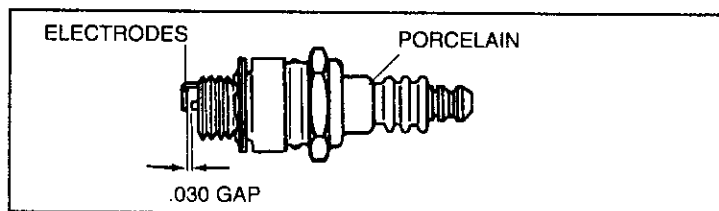

Figure 5

### 5 COOLING SYSTEM

**IMPORTANT:** Frequently remove any grass clippings, dirt and debris from cooling fins, air intake screen and levers and linkage (see Figure 6). This will help ensure adequate cooling and correct engine speed.

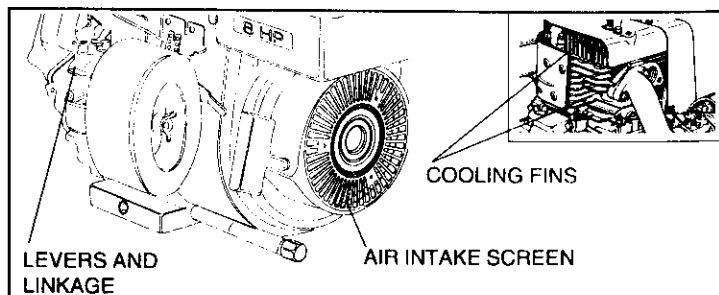

Figure 6

## MAINTENANCE (Continued)

- ⑥ **CHECK ENGINE AND EQUIPMENT OFTEN FOR LOOSE NUTS, BOLTS AND ATTACHMENTS AND KEEP THESE ITEMS TIGHTENED.**

## ADJUSTMENTS

DO NOT MAKE UNNECESSARY ADJUSTMENTS. FACTORY SETTINGS ARE SATISFACTORY FOR MOST APPLICATIONS AND CONDITIONS. IF ADJUSTMENTS ARE NEEDED, PROCEED AS FOLLOWS:

### ① CARBURETOR (see Figure 7):

If you think your carburetor needs adjusting, see your nearest SEARS, ROEBUCK AND CO. (OR SEARS CANADA, INC.) SERVICE CENTER. Engine performance should not be affected at altitudes up to 7,000 feet. For operation at higher elevations, contact your nearest SEARS, ROEBUCK AND CO. (OR SEARS CANADA, INC.) SERVICE CENTER.

### ② ENGINE SPEED:

- ⚠ **NEVER TAMPER WITH ENGINE GOVERNOR WHICH IS FACTORY SET FOR PROPER ENGINE SPEED. OVERSPEEDING ENGINE ABOVE FACTORY HIGH SPEED SETTING CAN BE DANGEROUS.**

**CHANGING OF ENGINE-GOVERNED SPEED WILL VOID ENGINE WARRANTY.**

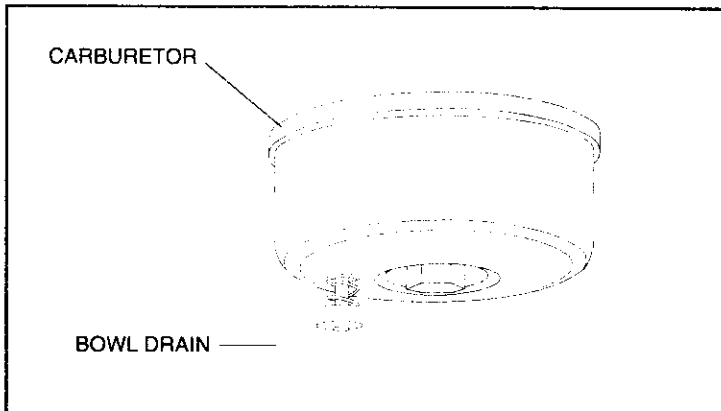

Figure 7

## STORAGE

- ⚠ **NEVER STORE ENGINE WITH FUEL IN TANK INDOORS OR IN ENCLOSED, POORLY VENTILATED AREAS WHERE FUEL FUMES MAY REACH AN OPEN FLAME, SPARK OR PILOT LIGHT AS ON A FURNACE, WATER HEATER, CLOTHES DRYER OR OTHER GAS APPLIANCE.**

IF ENGINE IS TO BE UNUSED FOR 30 DAYS OR MORE, PREPARE AS FOLLOWS:

### ① DRAIN FUEL SYSTEM:

Remove all gasoline from carburetor and fuel tank to prevent gum deposits from forming on these parts and causing possible malfunction of engine.

- ⚠ **DRAIN FUEL INTO APPROVED CONTAINER OUTDOORS, AWAY FROM OPEN FLAME. BE SURE ENGINE IS COOL. DO NOT SMOKE.**

Run engine until fuel tank is empty and engine stops due to lack of fuel.

**NOTE:** Fuel stabilizer (such as STA-BIL) is an acceptable alternative in minimizing the formation of fuel gum deposits during storage. Add stabilizer to gasoline in fuel tank or storage container. Always follow mix ratio found on stabilizer container. Run engine at least 10 minutes after adding stabilizer to allow it to reach carburetor.

### ② CHANGE OIL:

Change oil if it has not been changed in the last three (3) months. See "CHANGE OIL" instructions in "MAINTENANCE" section.

### ③ OIL CYLINDER BORE:

- Remove spark plug and pour one (1) ounce (30 ml) of clean engine oil into spark plug hole.
- Cover spark plug hole with a rag.
- Crank engine over, slowly, several times.

- ⚠ **AVOID SPRAY FROM SPARK PLUG HOLE WHEN CRANKING ENGINE OVER SLOWLY.**

- Install spark plug. Do not connect spark plug wire.

### ④ CLEAN ENGINE:

Remove any clippings, dirt, or chaff from exterior of engine.

## GENERAL

Just as your automobile needs professional mechanical maintenance from time to time, so does your Craftsman engine. Replacement of the spark plug and air cleaner is made necessary by NORMAL use. Professional Air-Cooled Engine Service is as close as your nearest Sears Roebuck and Co. (or Sears Canada, Inc.) Service Center.

A yearly check-up or tune-up by Sears is a good idea to avoid breakdowns or delay . . . do it at the end of the season, then you're ready for the next. We even prepare it for storage for you.

# TROUBLESHOOTING

**THE FOLLOWING MAY HELP AVOID A DELAY IN YOUR WORK OR  
SAVE THE EXPENSE OF A SERVICE CALL.**

<b>ENGINE FAILS TO START OR STARTS WITH DIFFICULTY</b>	
<b>CAUSE</b>	<b>REMEDY</b>
<p>Controls not in start position.</p> <p>Spark plug wire disconnected from spark plug.</p> <p>Spark plug fouled.</p> <p>Spark plug porcelain cracked.</p> <p>Insufficient fuel.</p> <p>Water or dirt in fuel.</p> <p>Improper carburetor adjustment</p>	<p>Move ENGINE CONTROL or equipment control to "HI" or START position. See "STARTING" instructions in this manual.</p> <p>Connect SPARK PLUG WIRE to SPARK PLUG.</p> <p>Remove SPARK PLUG and clean it. See "SPARK PLUG" instructions in "MAINTENANCE" section in this manual.</p> <p>Install new spark plug.</p> <p>Fill FUEL TANK per "BEFORE STARTING" instructions.</p> <p>Drain FUEL TANK and re-fill with clean, fresh gasoline. See "BEFORE STARTING" instructions in this manual.</p> <p>Adjust carburetor (if applicable). See "ADJUSTMENTS" section in this manual.</p>
<b>ENGINE LACKS POWER</b>	
<b>CAUSE</b>	<b>REMEDY</b>
<p>Dirty air cleaner.</p> <p>Improper carburetor adjustment.</p> <p>Lack of lubricaiton.</p>	<p>Replace or clean air cleaner per "AIR CLEANER" instructions in "MAINTENANCE" section in this manual.</p> <p>Adjust carburetor (if applicable). See "ADJUSTMENTS" section in this manual.</p> <p>Fill oil sump to proper level. See "BEFORE STARTING" instructions section in this manual.</p>
<b>ENGINE MISSES UNDER LOAD</b>	
<b>CAUSE</b>	<b>REMEDY</b>
<p>Spark plug fouled.</p> <p>Spark plug porcelain cracked.</p> <p>Improper spark plug gap.</p> <p>Improper carburetor adjustment</p>	<p>Remove SPARK PLUG and clean it. See "SPARK PLUG" instructions in "MAINTENANCE" section in this manual.</p> <p>Install new SPARK PLUG.</p> <p>Regap SPARK PLUG electrodes. See "SPARK PLUG" instructions in "MAINTENANCE" section in this manual.</p> <p>Adjust carburetor (if applicable). See "ADJUSTMENTS" section in this manual.</p>

# Federal and California Emission Control Systems Limited Warranty

## Utility and Lawn and Garden Engines

### CALIFORNIA & US EPA EMISSION CONTROL WARRANTY STATEMENT

The U. S. Environmental Protection Agency ("EPA"), the California Air Resources Board ("CARB") and Sears, Roebuck and Co. are pleased to explain the Federal and California Emission Control Systems Warranty on your new utility or lawn and garden equipment engine. In California, new 1995 and later utility and lawn and garden equipment engines must be designed, built and equipped to meet the State's stringent anti-smog standards. In other states, new 1997 and later model year engines must be designed, built and equipped, at the time of sale, to meet the U.S. EPA regulations for small non-road engines. Sears, Roebuck and Co. will warrant the emission control system on your utility or lawn and garden equipment engine for the periods of time listed below, provided there has been no abuse, neglect, unapproved modification, or improper maintenance of your utility or lawn and garden equipment engine.

Your emission control system may include parts such as the carburetor, ignition system and exhaust system. Also included may be the compression release system and other emission-related assemblies.

Where a warrantable condition exists, Sears, Roebuck and Co. will repair your utility or lawn and garden equipment engine at no cost to you for diagnosis, parts and labor.

### MANUFACTURER'S EMISSION CONTROL SYSTEM WARRANTY COVERAGE

Emission control systems on 1995 and later model year California utility and lawn and garden equipment engines are warranted for two years as hereinafter noted. In other states, 1997 and later model year engines are also warranted for two years. If, during such warranty period, any emission-related part on your engine is defective in materials or workmanship, the part will be repaired or replaced by Sears, Roebuck and Co.

### OWNER'S WARRANTY RESPONSIBILITIES

As the utility or lawn and garden equipment engine owner, you are responsible for the performance of the required maintenance listed in your Owner's Manual, but Sears, Roebuck and Co. will not deny warranty solely due to the lack of receipts or for your failure to provide written evidence of the performance of all scheduled maintenance.

As the utility or lawn and garden equipment engine owner, you should, however, be aware that Sears, Roebuck and Co. may deny you warranty coverage if your utility or lawn and garden equipment or a part thereof has failed due to abuse, neglect, improper maintenance or unapproved modifications.

You are responsible for presenting your utility or lawn and garden equipment engine to a Sears, Roebuck and Co. Authorized Service Outlet as soon as a problem exists. The warranty repairs should be completed in a reasonable amount of time, not to exceed 30 days.

Warranty service can be arranged by contacting either a Sears, Roebuck and Co. Authorized Service Outlet, or by contacting Sears, Roebuck and Co. at 1-800-473-7247.

### IMPORTANT NOTE

This warranty statement explains your rights and obligations under the Emission Control System Warranty ("ECS Warranty") which is provided to you by Sears, Roebuck and Co. pursuant to California law. See also the Sears, Roebuck and Co. Limited Warranties for Sears, Roebuck and Co. which is enclosed therewith on a separate sheet and also is provided to you by Sears, Roebuck and Co. The ECS Warranty applies only to the emission control system of your new engine. To the extent that there is any conflict in terms between the ECS Warranty and the Sears, Roebuck and Co. Warranty, the ECS Warranty shall apply except in any circumstances in which the Sears, Roebuck and Co. Warranty may provide a longer warranty period. Both the ECS Warranty and the Sears, Roebuck and Co. Warranty describe important rights and obligations with respect to your new engine.

Warranty service can only be performed by a Sears, Roebuck and Co. Authorized Service Outlet. At the time of requesting warranty service, evidence must be presented of the date of sale to the original purchaser. The purchaser shall pay any charges for making service calls and/or for transporting the products to and from the place where the inspection and/or warranty work is performed. The purchaser shall be responsible for any damage or loss incurred in connection with the transportation of any engine or any part(s) thereof submitted for inspection and/or warranty work.

If you have any questions regarding your warranty rights and responsibilities, you should contact Sears, Roebuck and Co. at 1-800-473-7247.

### EMISSION CONTROL SYSTEM WARRANTY

Emission Control System Warranty ("ECS Warranty") for 1995 and later model year California utility and lawn and garden equipment engines (for other states, 1997 and later model year engines):

**A. APPLICABILITY:** This warranty shall apply to 1995 and later model year California utility and lawn and garden equipment engines (for other states, 1997 and later model year engines). The ECS Warranty Period shall begin on the date the new engine or equipment is delivered to its original, end-use purchaser, and shall continue for 24 consecutive months thereafter.

**B. GENERAL EMISSIONS WARRANTY COVERAGE:** Sears, Roebuck and Co. warrants to the original, end-use purchaser of the new engine or equipment and to each subsequent purchaser that each of its utility and lawn and garden equipment engines is:

1. Designed, built and equipped so as to conform with all applicable regulations adopted by the Air Resources Board pursuant to its authority in Chapters 1 and 2, Part 5, Division 26 of the Health and Safety Code, and
2. Free from defects in materials and workmanship which, at any time during the ECS Warranty Period, will cause a warranted emissions-related part to fail to be identical in all material respects to the part as described in the engine manufacturer's application for certification.

**C. The ECS Warranty only pertains to emissions-related parts on your engine, as follows:**

1. Any warranted, emissions-related parts which are not scheduled for replacement as required maintenance in the Owner's Manual shall be warranted for the ECS Warranty Period. If any such part fails during the ECS Warranty Period, it shall be repaired or replaced by Sears, Roebuck and Co. according to Subsection 4 below. Any such part repaired or replaced under the ECS Warranty shall be warranted for any remainder of the ECS Warranty Period.
2. Any warranted, emissions-related part which is scheduled only for regular inspection as specified in the Owner's Manual shall be warranted for the ECS Warranty Period. A statement in such written instructions to the effect of "repair or replace as necessary", shall not reduce the ECS Warranty Period. Any such part repaired or replaced under the ECS Warranty shall be warranted for the remainder of the ECS Warranty Period.
3. Any warranted, emissions-related part which is scheduled for replacement as required maintenance in the Owner's Manual, shall be warranted for the period of time prior to the first scheduled replacement point for that part. If the part fails prior to the first scheduled replacement, the part shall be repaired or replaced by Sears, Roebuck and Co. according to Subsection 4 below. Any such emissions-related part repaired or replaced under the ECS Warranty, shall be warranted for the remainder of the ECS Warranty Period prior to the first scheduled replacement point for such emissions-related part.
4. Repair or replacement of any warranted, emissions-related part under this ECS Warranty shall be performed at no charge to the owner at a Sears, Roebuck and Co. Authorized Service Outlet.
5. The owner shall not be charged for diagnostic labor which leads to the determination that a part covered by the ECS Warranty is in fact defective, provided that such diagnostic work is performed at a Sears, Roebuck and Co. Authorized Service Outlet.
6. Sears, Roebuck and Co. shall be liable for damages to other original engine components or approved modifications proximately caused by a failure under warranty of an emission-related part covered by the ECS Warranty.
7. Throughout the ECS Warranty Period, Sears, Roebuck and Co. shall maintain a supply of warranted emission-related parts sufficient to meet the expected demand for such emission-related parts.
8. Any Sears, Roebuck and Co. authorized and approved emission-related replacement part may be used in the performance of any ECS Warranty maintenance or repair and will be provided without charge to the owner. Such use shall not reduce Sears, Roebuck and Co. ECS Warranty obligations.
9. Unapproved add-on or modified parts may not be used to modify or repair a Sears, Roebuck and Co. engine. Such use voids this ECS Warranty and shall be sufficient grounds for disallowing an ECS Warranty claim. Sears, Roebuck and Co. shall not be liable hereunder for failures of any warranted parts of a Sears, Roebuck and Co. engine caused by the use of such an unapproved add-on or modified part.

### EMISSION-RELATED PARTS INCLUDE THE FOLLOWING:

1. Carburetor Assembly and its Internal Components
  - a) Fuel filter
  - b) Carburetor gaskets
  - c) Intake pipe
2. Air Cleaner Assembly
  - a) Air filter element
3. Ignition System, including:
  - a) Spark plug
  - b) Ignition module
  - c) Flywheel assembly
4. Catalytic Muffler (if so equipped)
  - a) Muffler gasket (if so equipped)
  - b) Exhaust manifold (if so equipped)
5. Crankcase Breather Assembly and its Components
  - a) Breather connection tube

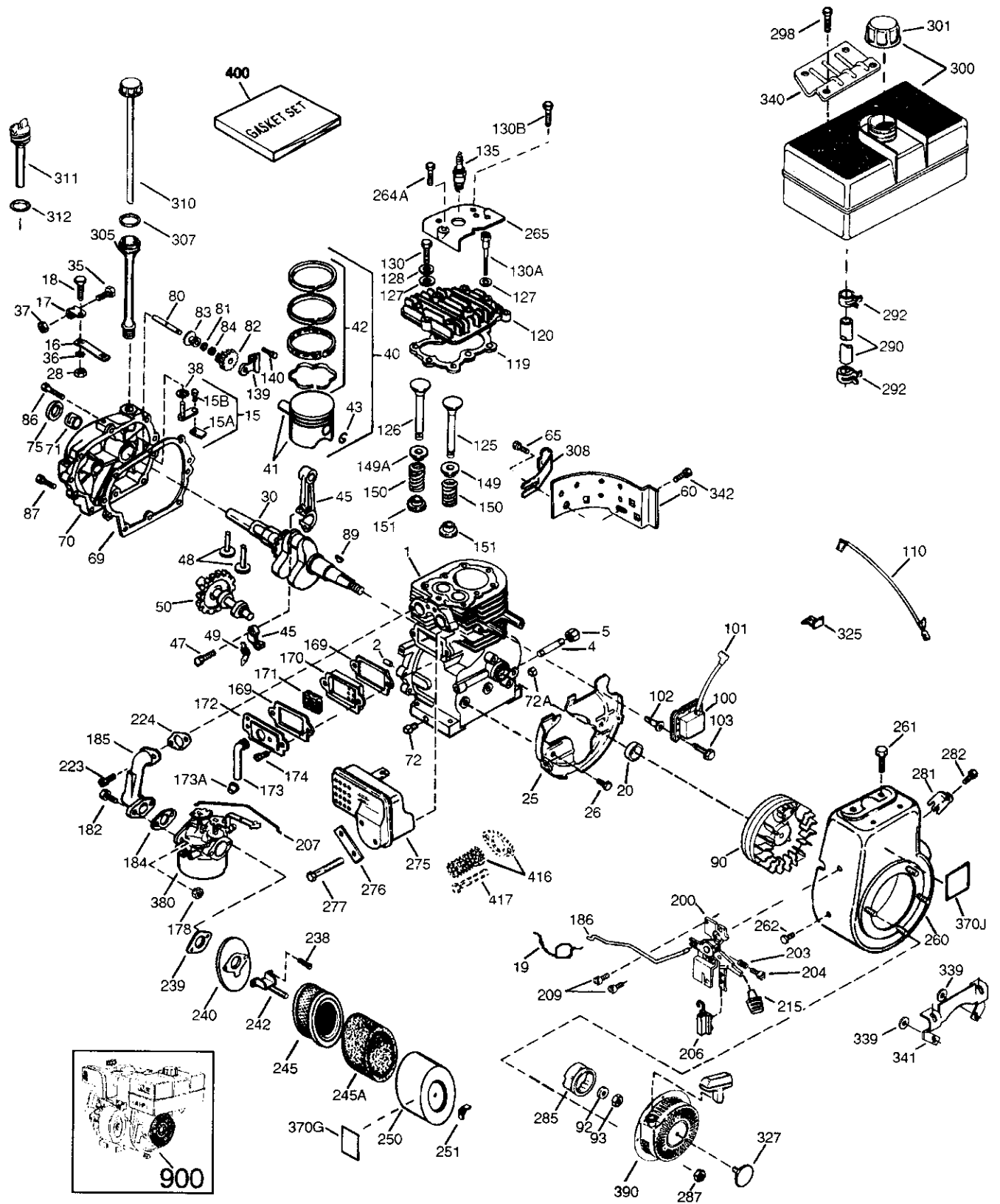



# CRAFTSMAN 4-CYCLE ENGINE

MODEL: 143.999011

Ref. No.	Part No.	Part Name	Ref. No.	Part No.	Part Name
1	35385	Cylinder (Incl. 2, 20, 72 & 72A)	126	34036	Intake Valve (1/32" OS) (Incl. 151)
2	27652	Dowel Pin	127	650691	Washer
4	0	Oil Drain Extension (Purchase Locally)	128	650690	Belleville Washer
5	30969	Extension Cap	130	650694A	Screw, 5/16-18 x 2"
15	30699C	Governor Rod (Incl. 15A & 15B)	130A	651031	Screw, 1/4-20 x 9/16"
15A	30700	Governor Yoke	130B	650273	Screw, 5/16-18 x 5/8"
15B	650494	Screw, 6-40 x 5/16"	135	33636	Resistor Spark Plug (RJ17LM)
16	33454	Governor Lever	139	33369	Governor Gear Bracket
17	29916	Governor Lever Clamp	140	650836	Screw, 10-24 x 1/2"
18	651028	Screw, Torx T-15, 8-32 x 3/8"	149	27882	Valve Spring Cap
19	34663	Speed Control Spring	149A	35862	Valve Spring Cap
20	35319	Oil Seal	150	27881	Valve Spring
25	36460	Blower Housing Baffle	151	32581	Valve Spring Keeper
26	650561	Screw, 1/4-20 x 5/8"	169	*27896A	Valve Cover Gasket
28	30322	Lock Nut, 8-32	170	28423	Breather Body
30	36283A	Crankshaft	171	28424	Breather Element
35	29826	Screw, 10-32 x 3/4"	172	28425	Valve Cover
36	29918	Lock Washer	173	36675A	Breather Tube
37	29216	Lock Nut, 10-32	173A	32446	Breather Tube Grommet
38	29642	Retaining Ring	174	650128	Screw, 10-24 x 1/2"
40	40011	Piston, Pin & Ring Set (Std.)	178	29752	Nut & Lock Washer, 1/4-28
40	40012	Piston, Pin & Ring Set (.010" OS)	182	30088A	Screw, 1/4-28 x 1"
41	40009	Piston & Pin Ass'y. (Std.) (Incl. 43)	184	*33263	Carburetor To Intake Pipe Gasket
41	40010	Piston & Pin Ass'y. (.010" OS) (Incl. 43)	185	34707	Intake Pipe
42	40013	Ring Set (Std.)	186	34667	Governor Link
42	40014	Ring Set (.010" OS)	200	34677	Control Bracket (Incl. 203 & 204)
43	27888	Piston Pin Retaining Ring	203	31342	Compression Spring
45	36897	Connecting Rod Ass'y. (Incl. 47 & 49)	204	651029	Screw, Torx T-10, 5-40 x 7/16"
47	651033	Connecting Rod Bolt	206	610973	Terminal
48	34034	Valve Lifter	207	33878	Throttle Link
49	36896	Oil Dipper	209	650821	Screw, 10-32 x 1/2"
50	35375	Camshaft (MCR)	215	35882	Control Knob
60	33273A	Blower Housing Extension	223	650378	Screw, Torx T-30, 5/16-18 x 1-1/8"
65	650128	Screw, 10-24 x 1/2"	224	*27915A	Intake Pipe Gasket
69	*35262A	Cylinder Cover Gasket	238	28820	Screw, 10-32 x 1/2"
70	35376	Cylinder Cover (Incl. 71, 75 & 80)	239	*27272A	Air Cleaner Gasket
71	35377	Crankshaft Bushing	240	37104	Air Cleaner Body
72	27642	Oil Drain	242	33267	Air Cleaner Bracket
72A	28534	Oil Drain	245	33268	Air Cleaner Filter
75	35319	Oil Seal	245A	35881	Air Cleaner Filter
80	31845	Governor Shaft	250	33269A	Air Cleaner Cover
81	30590A	Washer	251	650513	Wing Nut, 1/4-20
82	35378	Governor Gear Ass'y. (Incl. 81)	260	36250	Blower Housing
83	30588A	Governor Spool	261	650788	Screw, 5/16-18 x 3/4"
84	29193	Retaining Ring	262	29747B	Screw, Torx T-40, 5/16-24 x 21/32"
86	650833	Screw, 1/4-20 x 1-3/16"	264A	650802	Screw, 1/4-20 x 5/8"
87	650832	Screw, 1/4-20 x 1-11/16"	265	33272B	Cylinder Head Cover
89	32589	Flywheel Key	275	34185B	Muffler
90	611090	Flywheel	276	31588	Locking Plate
92	650880	Lock Washer	277	650729	Screw, 5/16-18 x 3-3/16"
93	650881	Flywheel Nut	281	33013	Starter Bubble Cover
100	35135	Solid State Ignition	282	650760	Screw, 8-32 x 3/8"
101	610118	Spark Plug Cover	285	35985B	Starter Cup
102	651024	Solid State Mounting Stud	287	29752	Nut & Lock Washer, 1/4-28
103	651007	Screw, Torx T-15, 10-24 x 15/16"	290	30962	Fuel Line
110	35187	Ground Wire	292	26460	Fuel Line Clamp
119	*36448	Cylinder Head Gasket	298	650665	Screw, 1/4-15 x 3/4"
120	36449	Cylinder Head	300	34186A	Fuel Tank (Incl. 292 & 301)
125	27878A	Exhaust Valve (Std.) (Incl. 151)	301	36246	Fuel Cap
125	27880A	Exhaust Valve (1/32" OS) (Incl. 151)			
126	34035	Intake Valve (Std.) (Incl. 151)			

\*Indicates Parts Included in Gasket Set, Ref. No. 400.

# CRAFTSMAN 4-CYCLE ENGINE

MODEL: 143.999011

Ref. No.	Part No.	Part Name	Ref. No.	Part No.	Part Name
305	35554	Oil Fill Tube	390	590746	Rewind Starter
307	35499	"O" Ring			(Note: This engine could have been built with 590704 starter.)
308	35540	Fill Tube Clip	400	36450B	Gasket Set (Incl. Items Marked *)
310	36205	Dipstick	416	34479A	Spark Arrestor Kit (Incl. 417)
311	35941	Dipstick (Incl. 312)	417	650696	Screw, 5/16-18 x 2-3/4"
312	*29673	"O" Ring	900		Replacement Engine 756332, Order From 71-999
325	29443	Wire Clip	900		Replacement Short Block 756331A, Order From 71-999
327	35392	Starter Plug		181-1199-11	Operator's Manual
339	35880	Spacer			*Indicates Parts Included in Gasket Set, Ref. No. 400.
340	34259	Fuel Tank Bracket			RPM High 3450 to 3750
341	34258A	Fuel Tank Bracket			RPM Low 1700
342	30063	Screw, Torx T-30, 1/4-20 x 1/2"			
370G	35274	Oil Instruction Decal			
370J	35703	Throttle Decal			
380	640112	Carburetor (Incl. 184)			

## CARBURETOR NO. 640112

Ref. No.	Part No.	Part Name
	640112	Carburetor (Incl. 184 of Engine Parts List)
1	631776A	Throttle Shaft & Lever Assembly
2	631970	Throttle Return Spring
4	631184	Dust Seal Washer
5	631183	Dust Seal (Throttle)
6	640109	Throttle Shutter
7	650506	Shutter Screw
10	632740	Choke Shaft & Lever Assembly
11	632043	Choke Return Spring
12	631184	Dust Seal Washer
13	631183	Dust Seal (Choke)
14	631753	Choke Shutter
15	630735	Choke Positioning Spring
16	632164	Fuel Fitting
17	651025	Throttle Crack Screw/Idle Speed Screw
18	630766	Tension Spring
20	640016	Idle Restrictor Screw
20A	640053	Idle Restrictor Screw Cap
25	631867	Float Bowl
27	631024	Float Shaft
28	632019	Float
29	631028	Float Bowl "O" Ring
30	631021	Inlet Needle, Seat & Clip (Incl. 31)
31	631022	Spring Clip
36	640113	Main Nozzle Tube
37	632547	"O" Ring, Main Nozzle Tube
40	640114	High Speed Bowl Nut
44	27110	Bowl Nut Washer
47	630748	Welch Plug, Idle Mixture Well
48	631027	Welch Plug, Atmospheric Vent

## REWIND STARTER NO. 590746

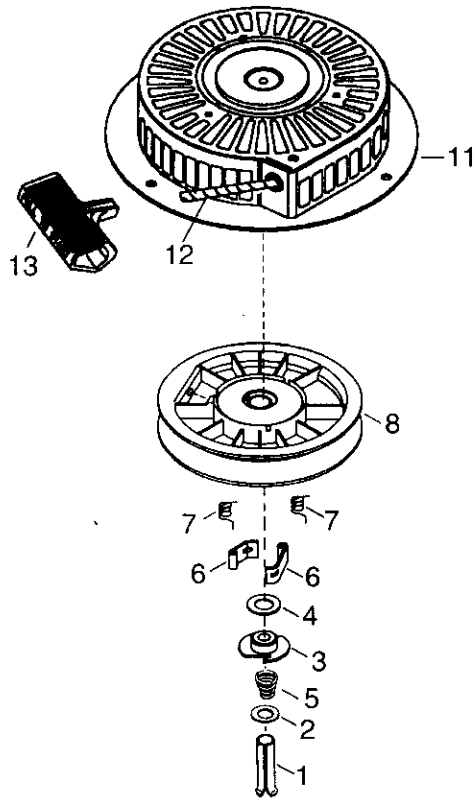

Ref. No.	Part No.	Part Name
	590746	Recoil Starter
1	590599A	Spring Pin (Incl. 4)
2	590600	Washer
3	590679	Retainer
4	590601	Washer
5	590678	Brake Spring
6	590680	Starter Dog
7	590412	Dog Spring
8	590681	Pulley & Rewind Spring Ass'y.
11	590747	Starter Housing Ass'y.
12	590535	Starter Rope ( 98" X 9/64" dia.)
13	590701	Starter Handle

## STARTER NO. 590704

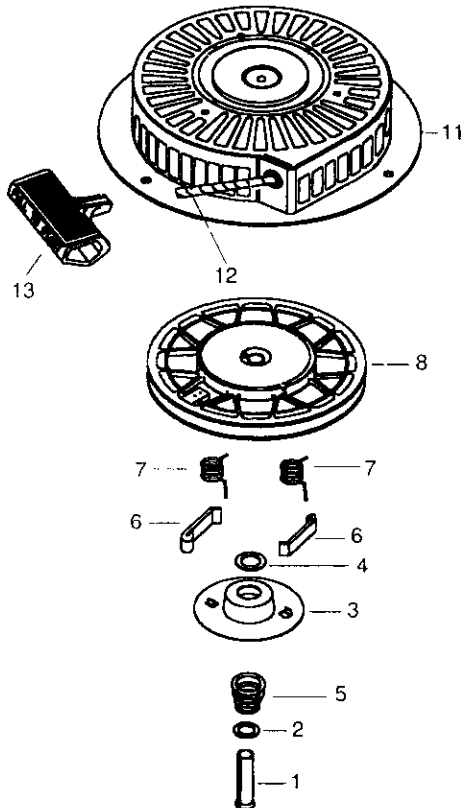

Ref. No.	Part No.	Part Name
	590704	Recoil Starter
1	590599A	Spring Pin (Incl. 4)
2	590600	Washer
3	590696	Retainer
4	590601	Washer
5	590697	Brake Spring
6	590698	Starter Dog
7	590699	Dog Spring
8	590700	Pulley & Rewind Spring Ass'y.
11	590705	Starter Housing Ass'y.
12	590535	Starter Rope ( 98" x 9/64" dia.)
13	590701	Starter Handle

# **SEARS**

## **operator's manual**

**MODEL NO. 143.999011**

**SOLID STATE IGNITION**

### **CAUTION:**

Read **RULES** for  
Safe **OPERATION**  
and **INSTRUCTIONS**  
Carefully

### ***How to ORDER Repair Parts***

The Model Number will be found on a decal on the blower housing (See Figure 1). Always mention the Model Number when requesting service or repair parts for your Craftsman Engine.

All parts listed herein may be ordered from any SEARS, ROEBUCK AND CO. or SEARS CANADA, INC. retail or catalog store. If the parts you need are not stocked locally, your order will be electronically transmitted to a Sears Repair Parts Distribution Center for expedited handling.

**WHEN ORDERING REPAIR PARTS, ALWAYS GIVE THE FOLLOWING INFORMATION AS SHOWN IN THIS LIST.**

1. The PART NUMBER
2. The PART DESCRIPTION
3. The MODEL NUMBER
4. The NAME OF ITEM - ENGINE

"Your Sears merchandise has added value when you consider that Sears has service units nationwide staffed with Sears trained technicians... professional technicians specifically trained on Sears products, having the parts, tools and equipment to insure that we meet our pledge to you ... we service what we sell."

**Sold by SEARS, ROEBUCK AND CO., CHICAGO, IL 60684 U.S.A.  
and SEARS CANADA, INC., TORONTO, ONTARIO, CANADA**