

SEWING MACHINE CABINET

OWNER'S MANUAL

Model Number 272.98200.491 Oak
272.98201.491 White

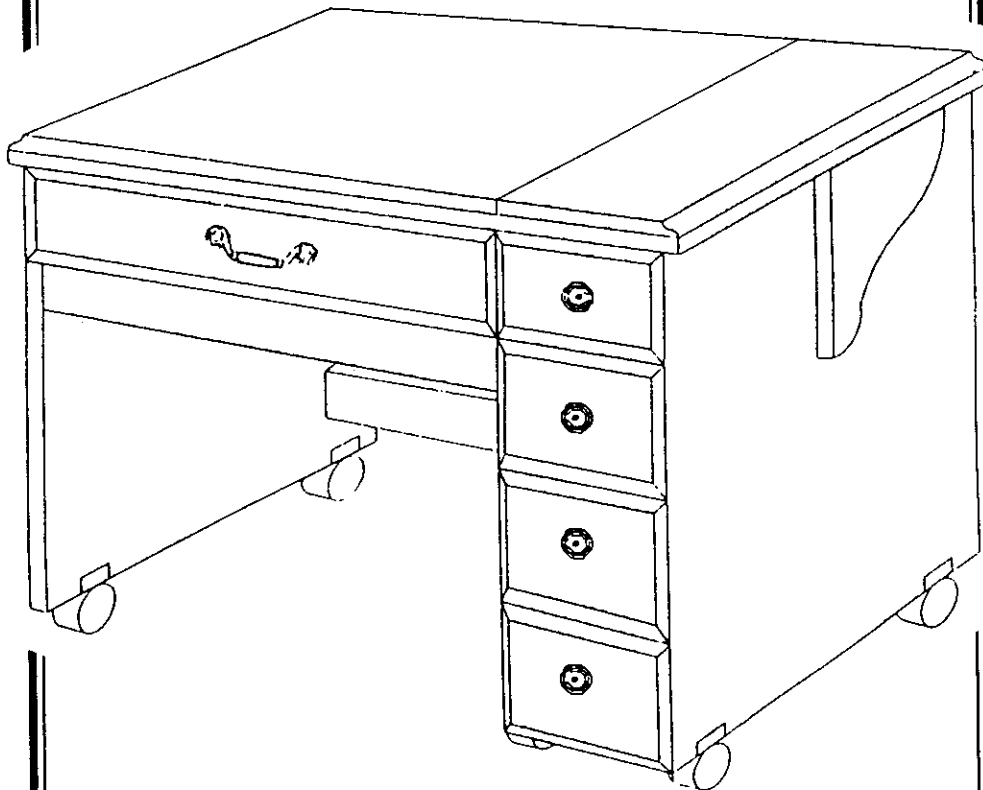

- **ASSEMBLY**
- **PARTS LIST**

IMPORTANT:
Read instructions before assembling.

98200-FC
98201-FC

Notice to Customer:

Before beginning assembly, remove all parts from the carton. Check closely with illustrations below to determine that all the parts are included.

For assembly or operating assistance, or to report any missing or damaged parts, you may call or write to:

1-800-533-7347

Arrow Specialty Furniture

(A division of ARROW Products Inc.)

P.O. Box 410, Elkhorn, WI 53121

TO ORDER REPLACEMENT PARTS CALL 1-800-366-7278

PLEASE NOTE: To assure proper handling of replacement parts please include the following information:

Model Number of Unit - **98200.491 (Oak)**

98201.491 (White)

Production ID Number

Number of Parts Required

Your Name, Address, and Phone Number

Top Assembly

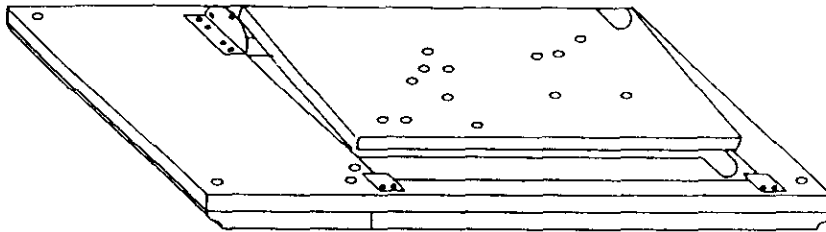

Right Leaf

Left Leaf

Right

Left

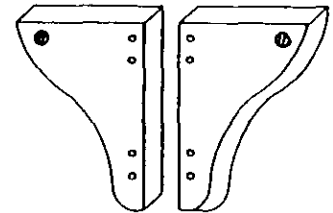

Leaf Supports

**Partition
(Right View)**

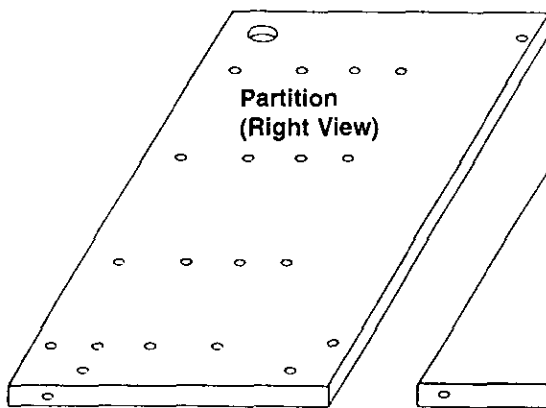

**Left Side
Panel**

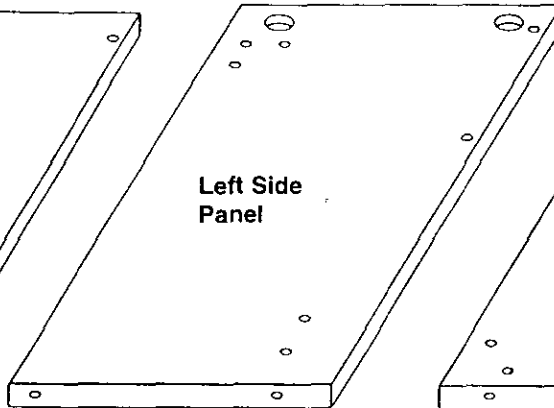

**Right Side
Panel**

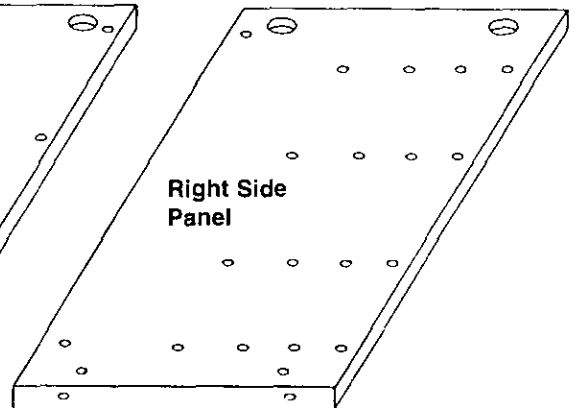

Front

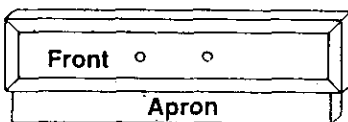

Apron

Compartment Back

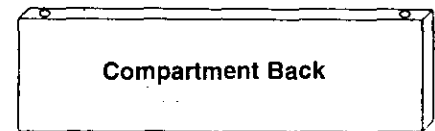

Top Drawer Front

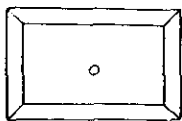

Front Brace



Compartment Bottom



**Lower Drawer Fronts
(3)**

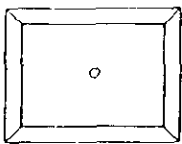







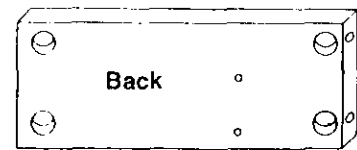



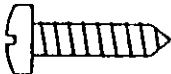

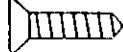
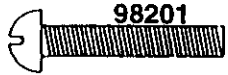
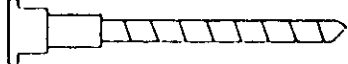
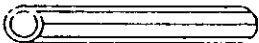



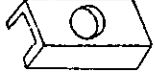



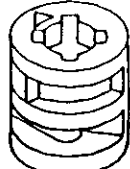

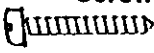
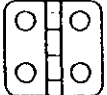

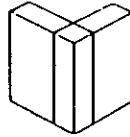
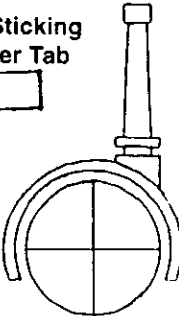
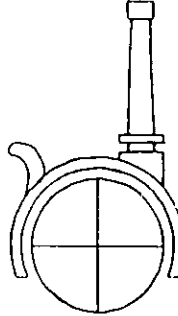
Back Brace

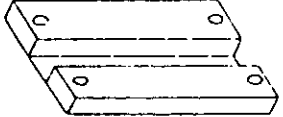
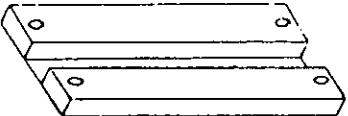
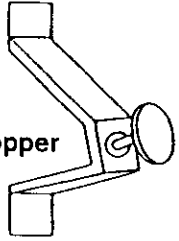
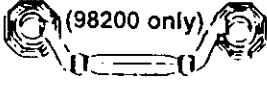

Back

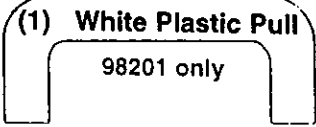
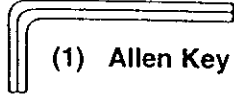

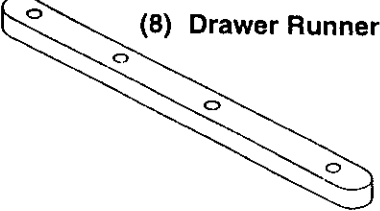
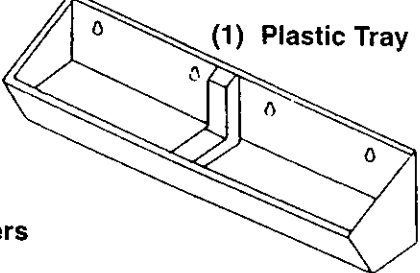
Hardware Included

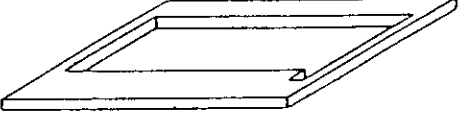
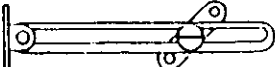
- (6) #8x1/2" Panhead Screws 
- (6) #5x1/2" Flathead Screws 
- (32) #6x1" Flathead Screws 
- (16) #8x5/8" Flathead Screws 
- (4) #8x7/8" Machine Screw 98201 
- (3) 1-1/2" Screw 
- (6) Wood Dowels 
- (2) Mounting Bolts 
- (2) Wing Nuts 
- (2) Zinc Flat Washers 
- (5) Caster Clips 
- (5) Caster Insert 
- (21) Connecting Bolts 
- (2) #6x5/8" Brass Panhead Screws 
- (21) Cams 
- (4) 2 PC. Knobs (98200 Metal) 
- (98201 Ceramic) 
- (2) #6x1" Panhead Screw (98201) 
- (4) Support Hinge 
- (4) 8/32x1" Knob Bolt (98200 only) 
- (16) Drawer Connectors 
- (3) Non-locking Casters 
- (2) Locking Casters 
- (2) Self Sticking Rubber Tab 
- (2) Bronze Strike Washers 
- (2) Round Magnet 
- (4) Drawer Backs 
- (8) Drawer Sides 
- (1) Platform Stopper 
- (1) Metal Handle (98200 only) 
- (2) 8/32x3/4" Handle Bolt (98200 only) 
- (1) White Plastic Pull (98201 only) 
- (1) Allen Key 
- (2) Rubber Bumpers 
- (8) Drawer Runners 
- (1) Plastic Tray 
- (4) Drawer Bottoms 
- (1) Sewing Insert 
- (1) Front Support 

Understanding How the "ARROW-LOC" Cam Fastener Works.

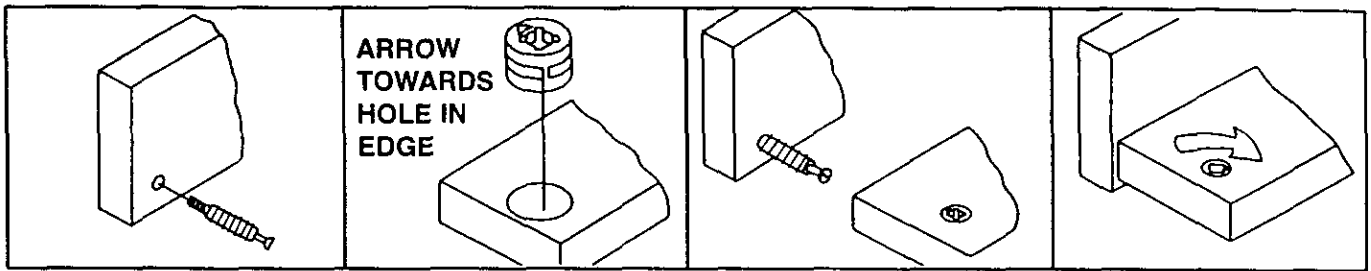

1. Position bolt in pre-drilled hole and turn until tight.
2. Press cam into pre-drilled hole until flush with surface.
3. Insert bolt through pre-drilled hole in edge of panel.
4. To lock, rotate cam until tight, using allen key provided.

Cabinet Assembly

Step 1. Place Top, Partition and Left and Right Sides on a flat protected surface (to prevent scratching of parts) and thread connecting bolts (21 total) into pre-drilled holes (as shown in FIG. 1). Turn Partition over and thread in the remaining bolts as indicated below (FIG. 1A).

NOTE:
● = Connecting Bolt

FIG. 1

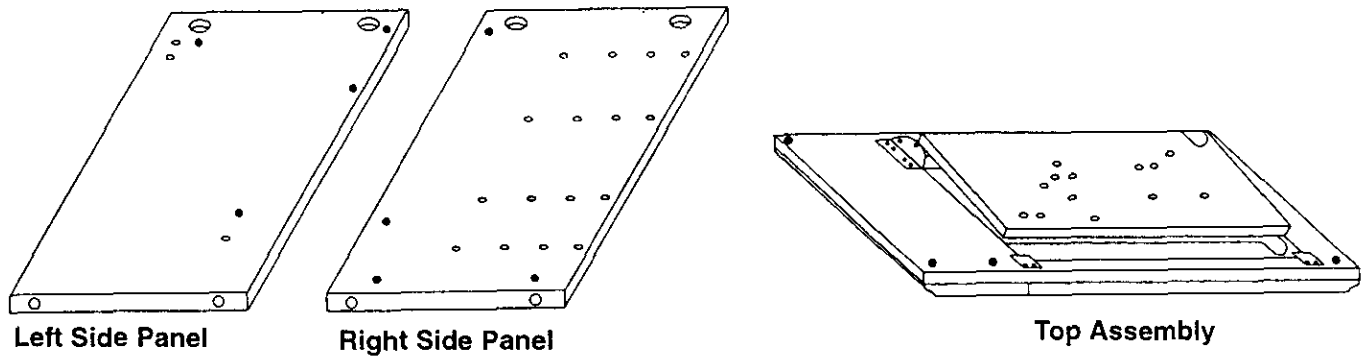
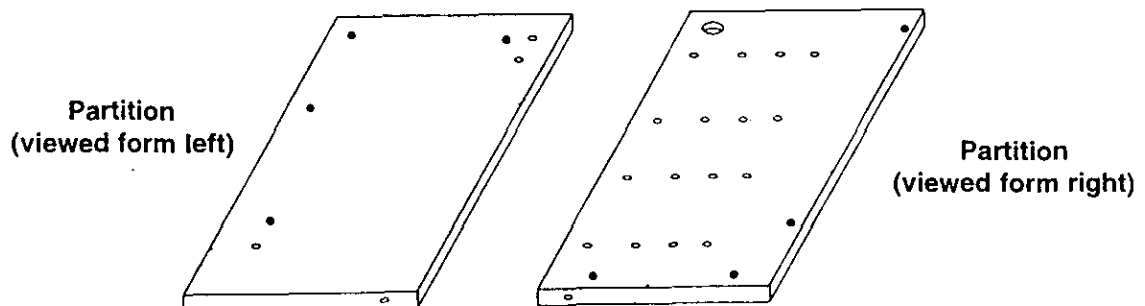



FIG. 1A



Step 2. Place parts shown below on a flat surface and press cam into pre-drilled holes provided (as illustrated in FIG. 2). After cams have been inserted (21 total), you may now attach the eight (8) drawer runners using (32) #6x1" Flathead Screws (FIG. 2A). After attaching the runners, insert the wood dowels (6) in the Front Assembly, Front Brace and Back Brace, (as shown in FIG. 2B).

NOTE:
 = Cam

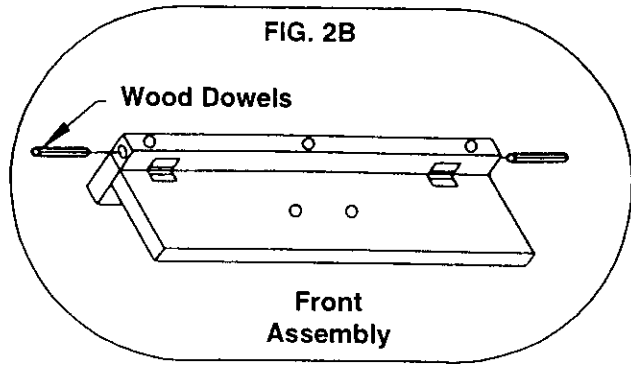
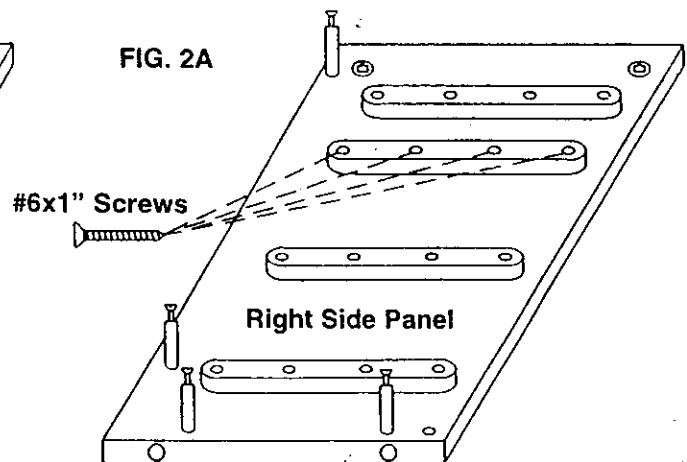
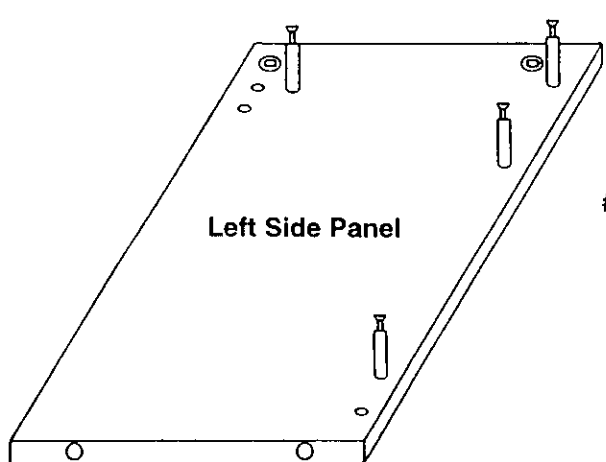
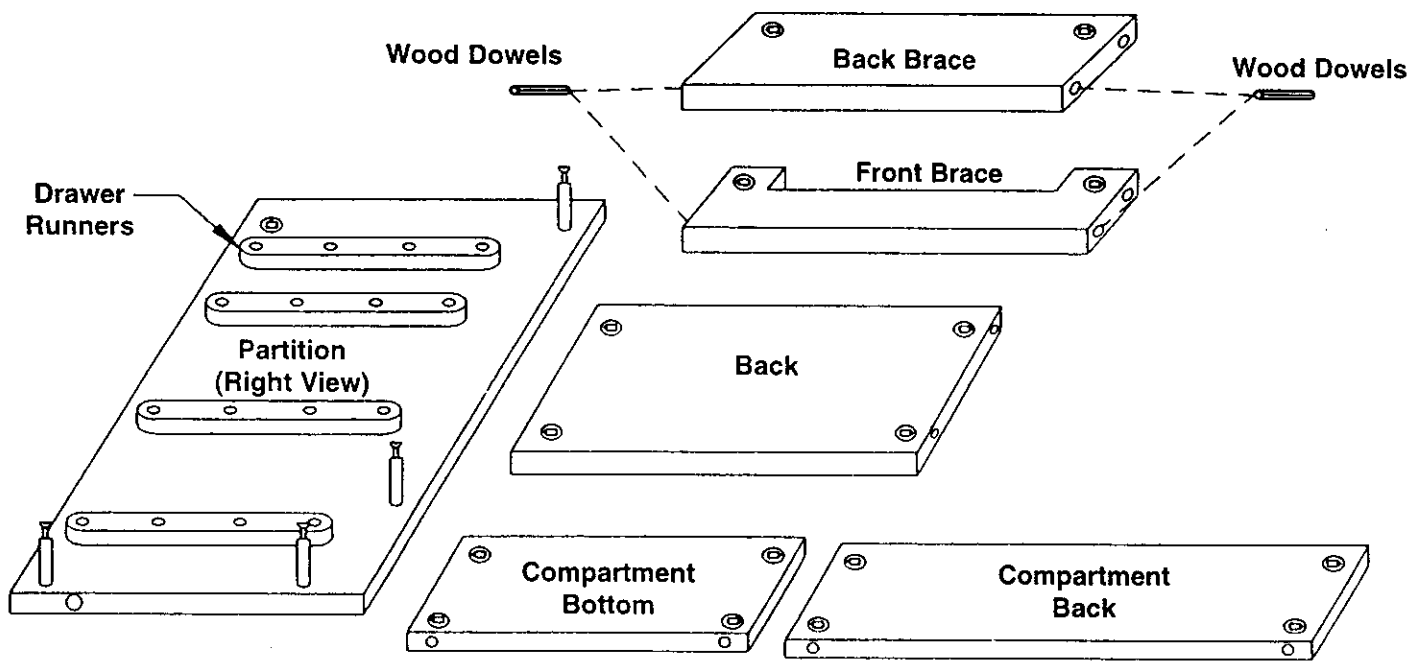
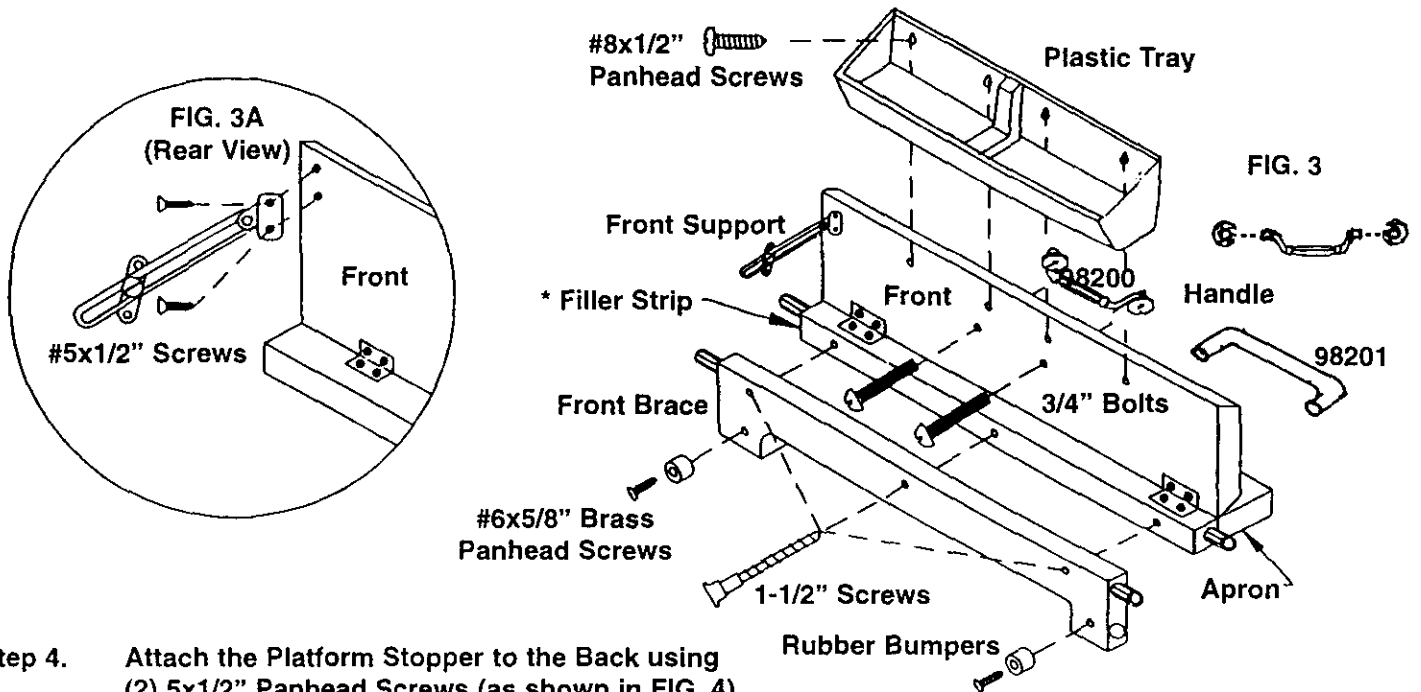

FIG. 2



Step 3. Attach Front Brace to Filler Strip on back side of Front using (3) 1-1/2" Screws. Be sure to position Brace as shown, cut-out down. Attach the Handle with (2) 8/32x3/4" Bolts (see note below) for Metal or (2) #6x1" Panhead Screws for White Plastic Handle to the Front. Attach Rubber Bumpers to the Front Brace using (2) #6x5/8" Panhead Screws (as shown in FIG. 3). Attach the Front Support to the back side of the Front using (2) #5x1/2" Flathead Screws (as shown in FIG. 3A). Attach the Plastic Tray to the inside of Front (as shown in FIG. 3). with (4) #8x1/2" Panhead Screws.



Step 4. Attach the Platform Stopper to the Back using (2) 5x1/2" Panhead Screws (as shown in FIG. 4). Rubber rest should be closer to edge.

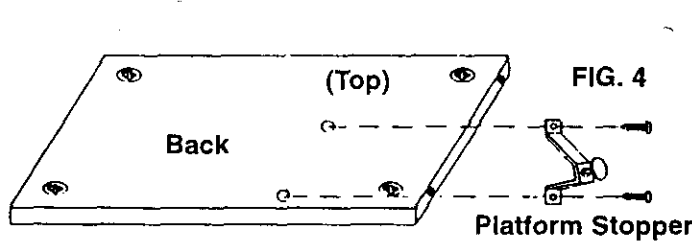

Step 5. Begin assembly by guiding the Back, Front Assembly and Back Brace onto the connecting bolts and dowels in the Left Side (as shown at right in FIG. 5); turn the back upside down and attach it FIRST to help support Left Side during assembly. Turn cams to Locked Position.

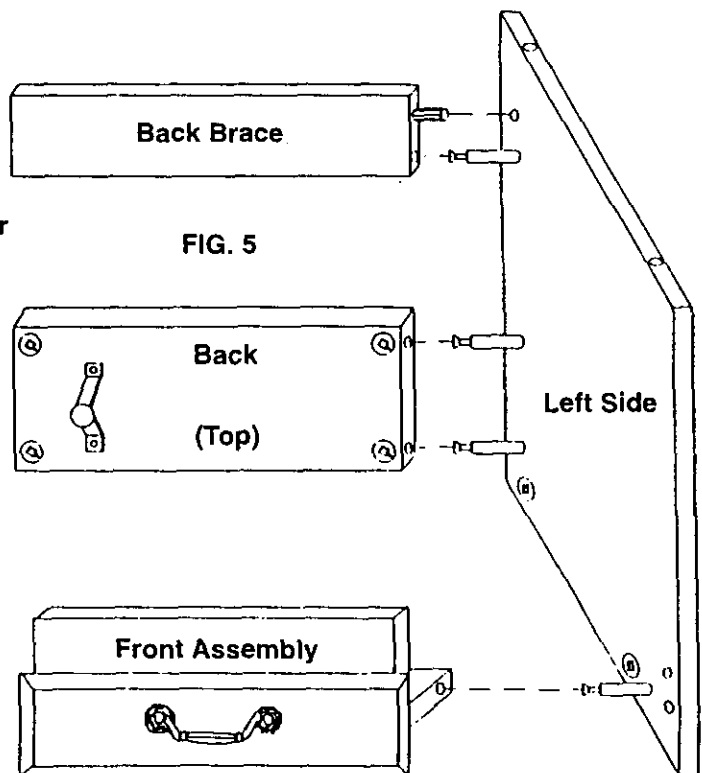

NOTE: The Metal Handle pull is a 3 piece pull, 2 Rosettes and Handle. Attach the 2 Rosettes loosely on front. Insert handle into end holes and tighten.

* Not previously identified; part of Front Assembly.

Step 6. Attach Partition by guiding the Connecting Bolts into holes in the Back Brace, Back, and Front Assembly; also allow Dowels in the Front Assembly and Back Brace to enter holes in the Partition (as shown in FIG. 6).

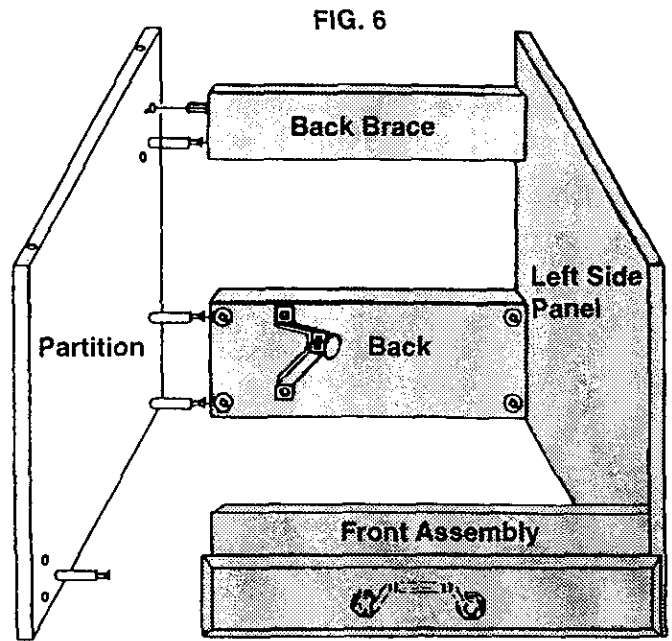

Step 7. Attach Compartment Back to Partition, aligning Cam holes with Bolts. Panel should be flush at top and bottom, when aligned with Bolts, turn Cams to locked position. Attach Compartment Bottom to partition, (taped edge to front) again aligning with Bolts, turn Cams to locked position. Attach Right Side to Compartment Back and Bottom; turn Cams to locked position (see FIG. 7).

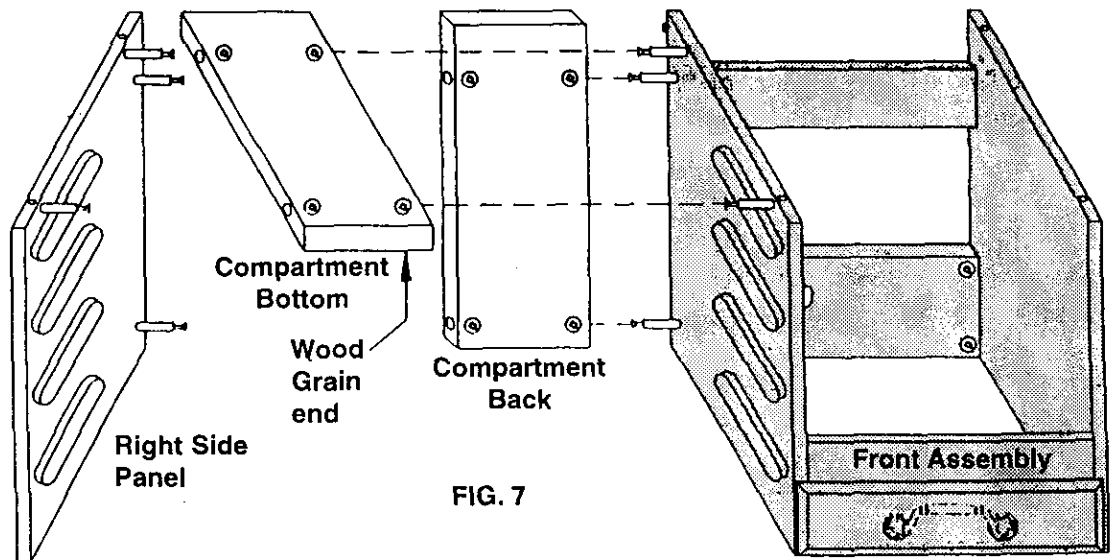

Step 8. Place Clips and Inserts, in that order, (5) where indicated on bottom of Side Panels and Partition. Tap in Casters (as shown in FIG. 7A), "LOCKING" type in front, "NON-LOCKING" in the rear and on Partition.

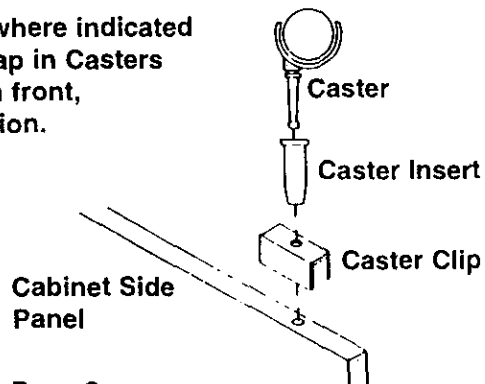
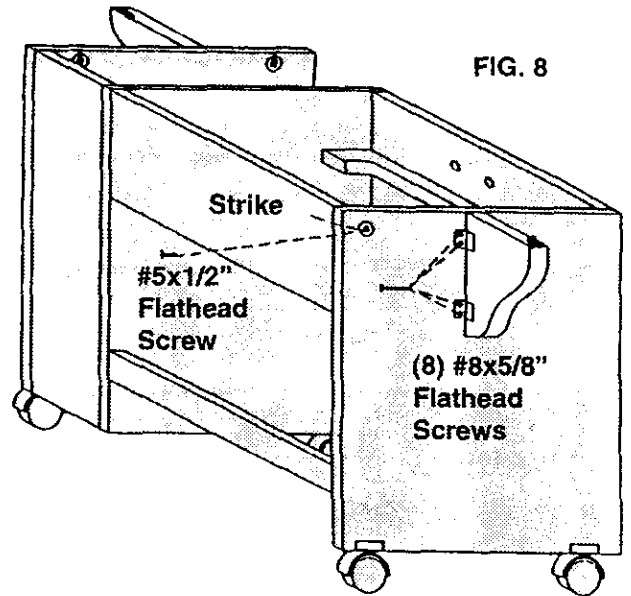
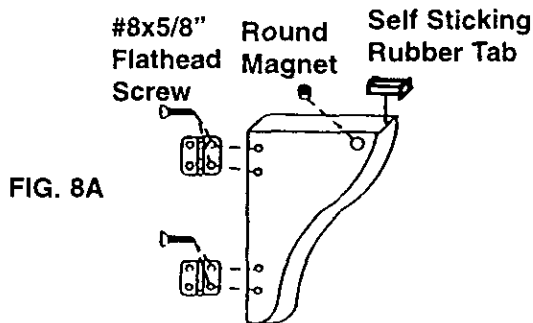

FIG. 7A

NOTE: The following assemblies should be done with Cabinet upright.

Step 9. Attach Hinges to Leaf Supports with (4) #8x5/8" Flathead screws each, tap Magnet with hammer, (as shown in FIG. 8A). Attach Bronze Strikes to outside of Left and Right sides with #5x1/2" Flathead Screw as in FIG. 8. Attach Self Sticking Rubber Tab to the top outside edge of each Leaf Support, as in FIG. 8A. Attach Leaf Support to right and Left Sides with (8) #8x5/8" Flathead Screws. Wings should fold to back of cabinet (see FIG. 8).



CAUTION: When applying the SELF STICKING RUBBER TAB, CAREFULLY REMOVE THE WHITE PAPER BACKING ONLY.

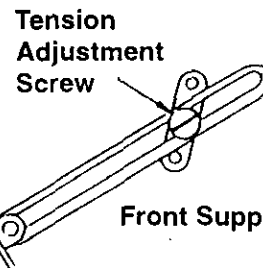

Step 10. Attach the Front Support to the cabinet Partition using (2) #5x1/2" Flathead Screws (as shown in FIG. 9). Tension can be adjusted on the Front Support by tightening the adjustment screw (as shown in FIG. 9A).

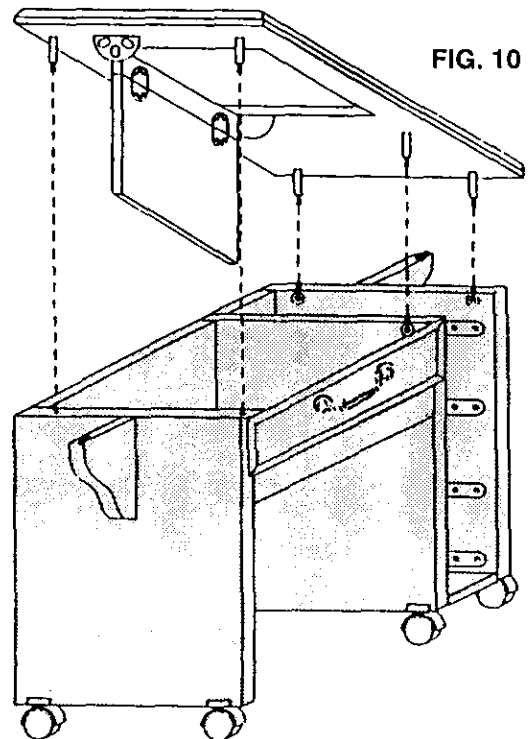
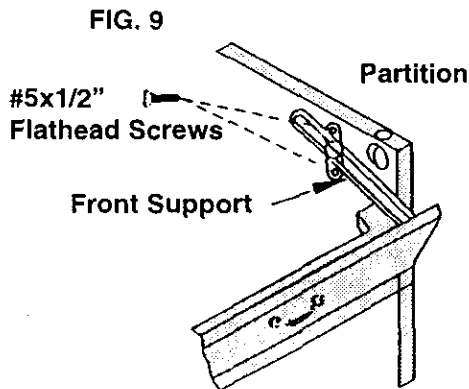

Step 11. Turn the Top over (with Platform hanging down) and guide the Connecting Bolts into the holes on the top edge of the Sides and Partition. Open leaves to rest on Leaf Supports. Reach through the opening in the Top and turn Cams to the Locked position (as shown in FIG. 10). Now reach into the Compartment and Lock the Cams in the same manner.

Top/Base Assembly

98200-7
98201-7

Assembling the Drawer

Begin Drawer assembly by inserting Drawer Connectors into the ends of the (4) Drawer Backs. (as shown in FIG. A). Push Connectors all the way into the Drawer Back until the tabs lock into place.

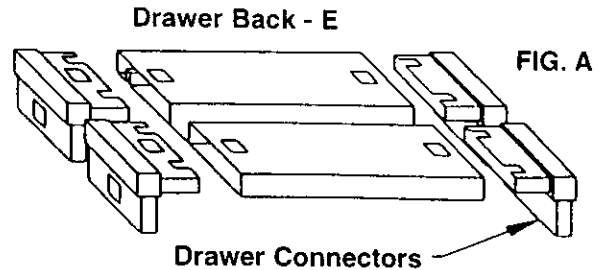
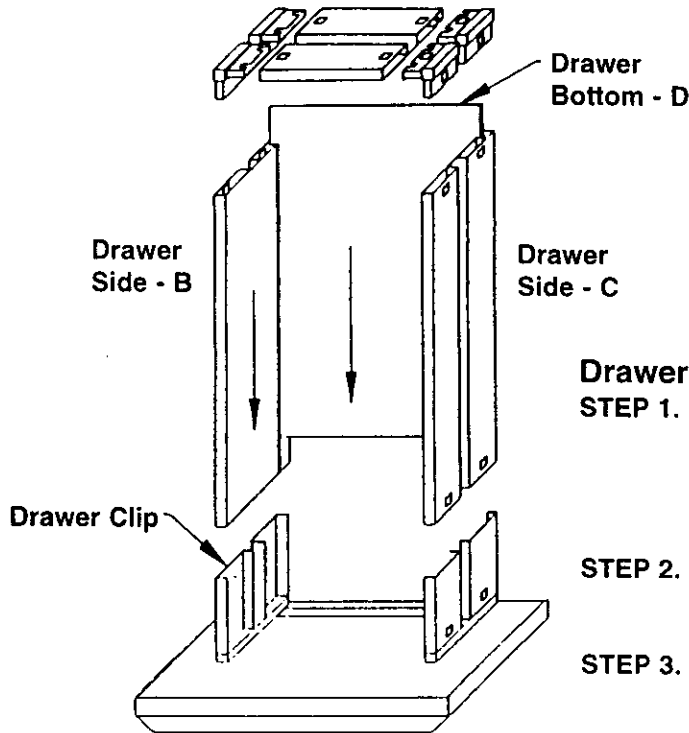

Drawer Assembly

- STEP 1. Attach DRAWER Sides B and C to Drawer Front-A. Align Drawer Bottom grooves in Sides with Drawer Bottom groove in Drawer Front. Snap Drawer Sides onto clips on Drawer Front (see FIG. B).
- STEP 2. Slide Drawer Bottom-D along grooves on the Sides into the Groove in Drawer Front.
- STEP 3. Align groove in Back-E with the Drawer Bottom-D and snap Back corner clips into Sides-B and C.
- STEP 4. Attach the Knobs to the Molded Drawer Fronts using (4) 7/8" Bolts for Ceramic Knobs or (4) 8/32x1" Bolts for Metal Knobs.

PLEASE NOTE:

BE SURE TO KEEP THE GROOVES IN DRAWER PARTS (FOR DRAWER BOTTOM) ALIGNED WHEN ASSEMBLING THE DRAWER.

Assemble Knob and Sleeve as Shown in FIG. C-A

The Drawers may now be installed into your cabinet as shown, with the Smaller Drawer at the top and the (3) Larger Drawers on the bottom Runners (as shown in FIG. C).

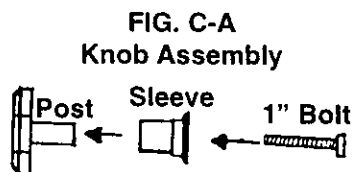

Smaller Drawer

3-Larger Drawers

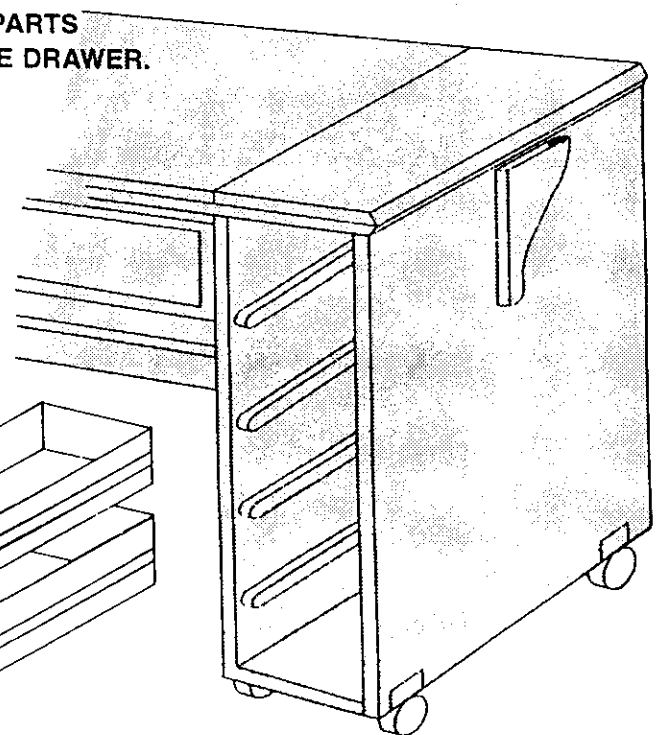
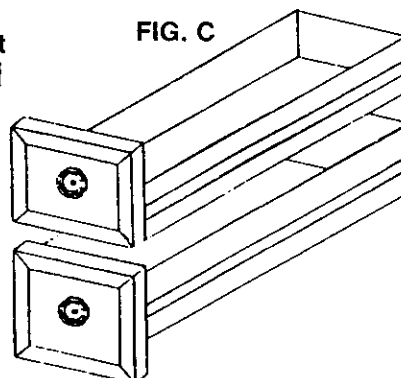

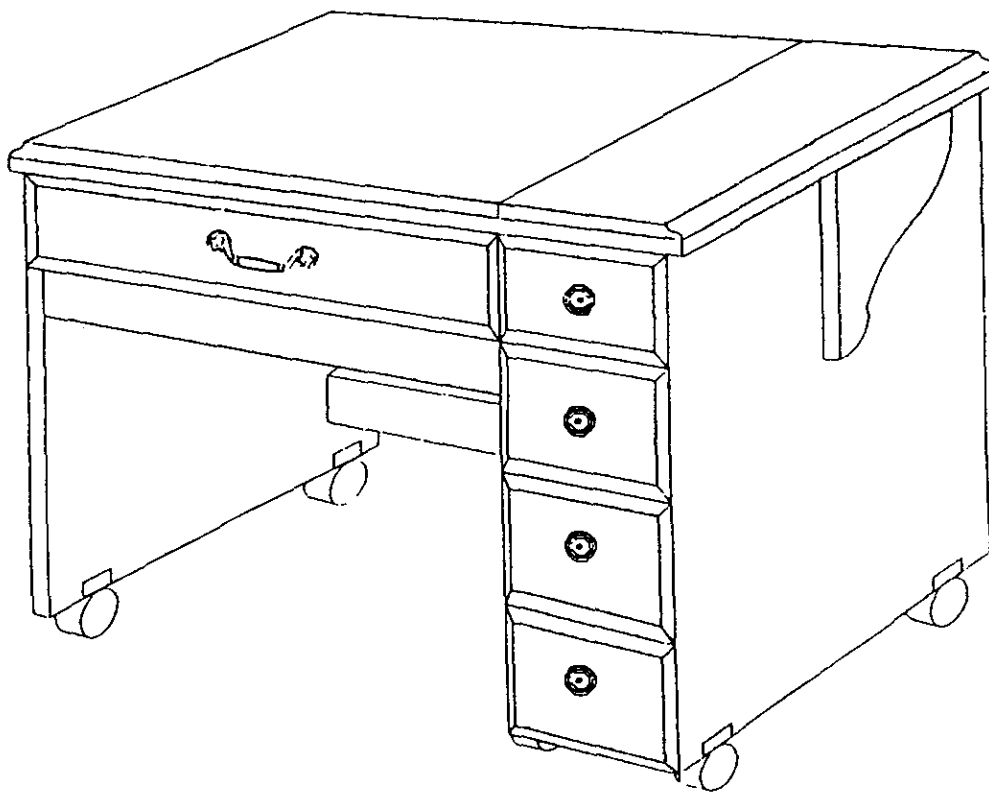

CONGRATULATIONS

Your Sewing Cabinet is Now Ready for the Machine

Installing Sewing Machine in your new Cabinet.

It may be helpful to read the directions for operating the mechanism before proceeding with the following steps. See page 11, and FIG. 12, on this page.

- STEP 1. To prevent damage to Cabinet surface, place cushioning material just to the left of cut-out. Lay the sewing machine on its back, on top of cushioning material.
- STEP 2. With Platform in the flatbed position, place Plastic insert into position, making sure the ruler is facing front. This will aid you in positioning the sewing machine.
- STEP 3. Feed machine receptacle cord from the machine control pedal, up through the slot on the right side of the machine platform.
- STEP 4. Insert machine receptacle into terminals provided on the right side of the machine; (this may vary with some machines).
- STEP 5. Thread the two Headmounting Bolts (provided) into the two threaded holes located on the bottom of your machine; twist tight to the collar; (number and type of Bolts may vary with some machines).
- STEP 6. With the plastic insert in place (see page 11) and the front left corner of the machine almost touching the front left corner of the insert, lower machine onto the Platform, aligning bolts with machine onto the Platform; (some machines may require new holes to be drilled). Next, secure machine to Platform with Washers and Wing Nuts, from underneath Platform. See. FIG. 11 and 11A.

While holding machine, lower it into storage position, raise it up to free the arm (to check its operation) then lower it back to the flatbed position. Read operating instructions on page 11 first.

Maintenance of Cabinet:

Clean as you do your other fine furniture, using a soft cloth and polish.

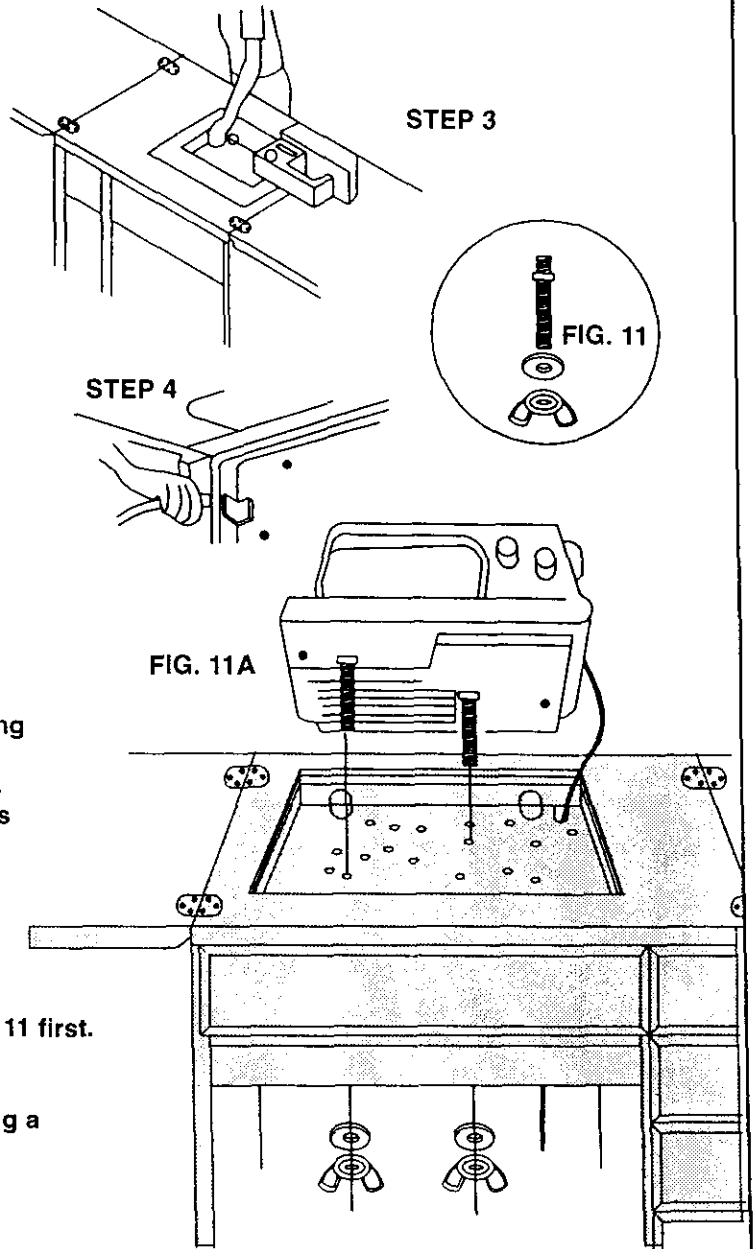

Understanding How Your Mechanism Works:

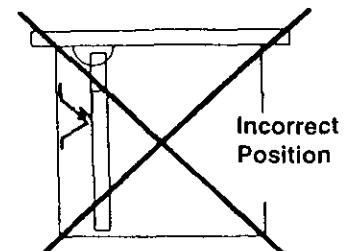
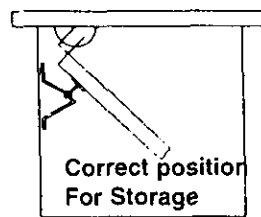
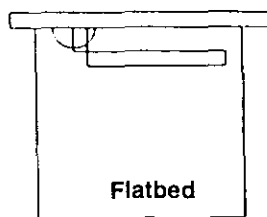
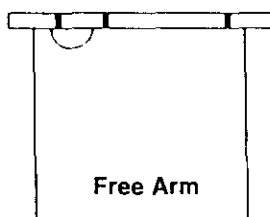

IMPORTANT: To move smoothly from one position to another, make sure you do so slowly with both hands, and always make sure you hear the **CLICK** after each position change. The machine may be lowered for proper clearance from closed leaf while in the storage position by adjusting stopper bolt on back panel.

Operating the Mechanism in your Cabinet

To move from **FLATBED POSITION TO FREE-ARM position:** (See FIG. 13, 14 and 15.)

- (1.) Remove **INSERT**
- (2.) Lift and tilt machine slightly backwards.
- (3.) Rotate release lever to the right, (clockwise) to unlock.
- (4.) Lift and bring machine forward until it locks into the new position. Listen for **CLICK**. Let platform rest on tabs.

To move your machine from **FREE-ARM position to FLATBED position:** (See FIGS. 13, 14 and 15).

- (1.) Lift and tilt machine slightly forward.
- (2.) Rotate release lever to the right, (clockwise) to unlock.
- (3.) Allow the machine to lower into cabinet. When you hear the **CLICK** you will know it is in the **FLATBED** position. Let platform rest on front brace.
- (4.) Replace **INSERT**.

FIG. 13

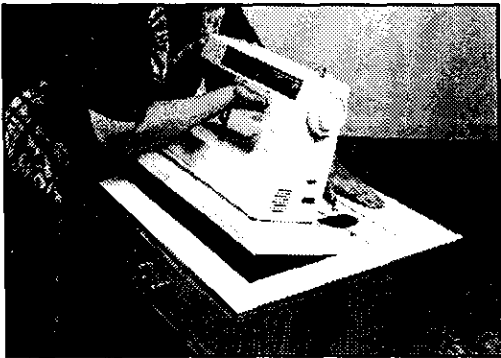

FIG. 15

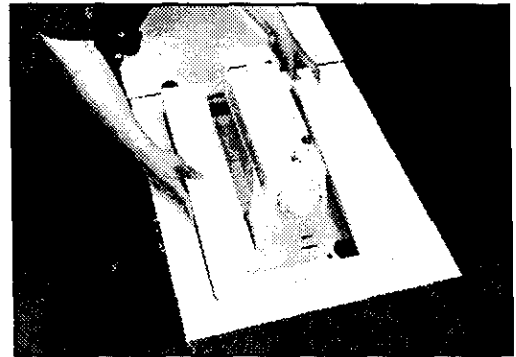

FIG. 14

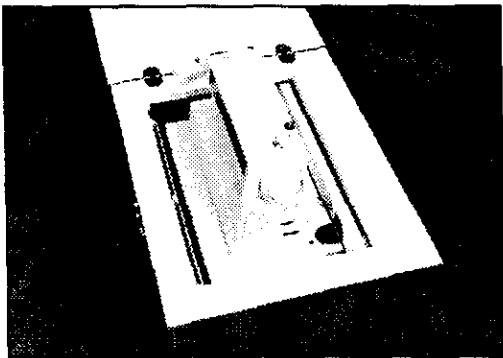

FIG. 16

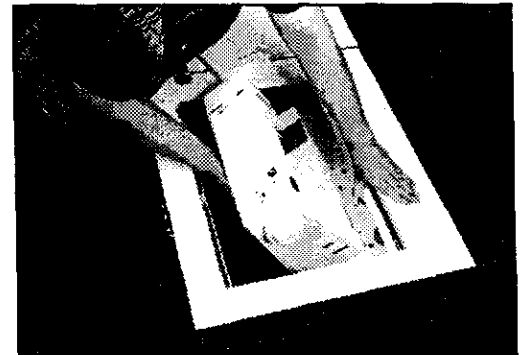
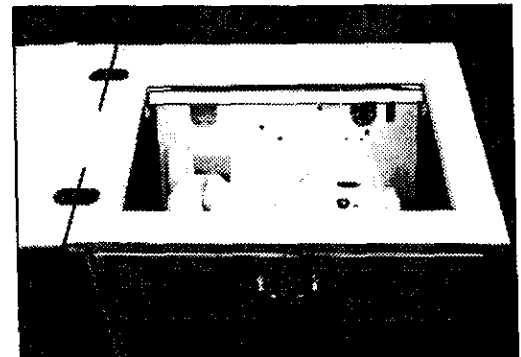

FIG. 17



To move machine from **FLATBED position to STORAGE position:** (See FIGS. 15, 16 and 17).

- (1.) Remove **INSERT**.
- (2.) Once again, lift and tilt machine backwards.
- (3.) Rotate release lever to the right, (clockwise) to unlock
- (4.) Lower and push machine backwards and up until it locks into position. **MAKE SURE YOU HEAR THE CLICK**. See FIGS. 16 and 17.
- (5.) Replace **INSERT** in top opening. Should the Insert not sit flush to the cabinet top, adjust the Stop Bolt on the back of the cabinet to lower the machine sufficiently.

Wood Parts List

Top Assembly

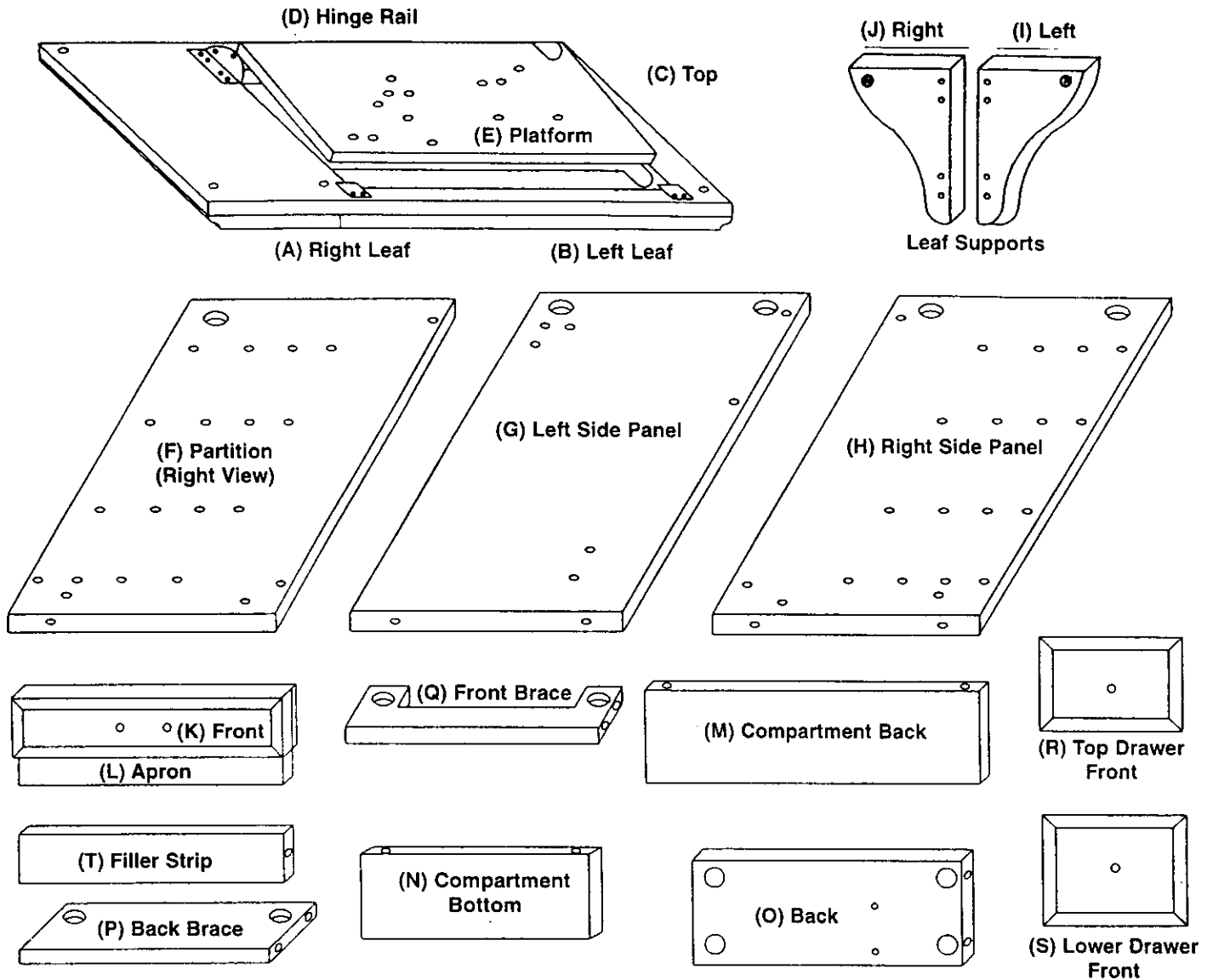

REF.	DESCRIPTION	PART #	PART #
		98200(OAK)	98201(WHITE)
A	Right Leaf	003272	003200
B	Left Leaf	003273	003201
C	Top	003276	003206
D	Hinge Rail	003266	003211
E	Platform	003265	003209
F	Partition	003275	003204
G	Left Side	003260	003202
H	Right Side	003274	003203
I	Left Leaf Support	003271	003218
J	Right Leaf Support	003282	003219
K	Front	003278	003208

REF.	DESCRIPTION	PART #	PART #
		98200(OAK)	98201(WHITE)
L	Apron Rail	003267	003212
M	Compartment Back	003279	003210
N	Compartment Bottom	003277	003207
O	Back	003262	003205
P	Back Brace	003269	003214
Q	Front Brace	003270	003215
R	Drawer Front (Small)	003280	003216
S	Drawer Front (Large)	003281	003217
T	Filler Strip	003268	003213

OTHER PARTS LIST



(HHH) 8x5/8" FL-ZN-YW
Leaf Screw

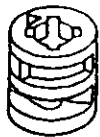

(A) Cam



(B) Connecting Bolts



(C) Rubber Bumper



(D) Mounting Bolts



(E) Zinc Flat Washers



(F) Wing Nut



(G) Round Magnet



(H) Leaf Support Hinge



(I) Bronze Strike Washer

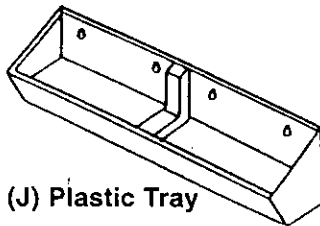

(J) Plastic Tray

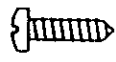

(K) #8x1/2" Panhead Screw



(L) Knob Screw (98201)



(M) #8x5/8" Ant. Brass FH Screw



(N) #5x1/2" Flathead Screw



(HH) Knob Ceramic (98201)

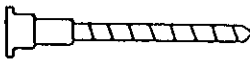

(O) 1-1/2" Wood Screw



(ZZZ) 6x5/8" Brass Panhead

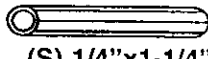

(S) 1/4"x1-1/4" Wood Dowel

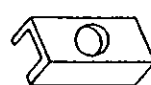

(T) 3/4" Caster Clip

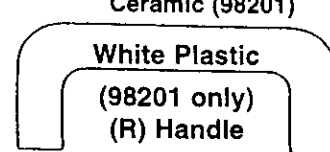

White Plastic (98201 only)
(R) Handle

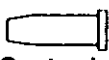

(U) Caster Insert

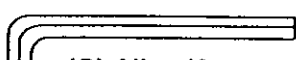

(Q) Allen Key

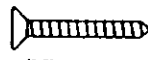

(Y) #6x1" Flathead Screw



(Z) Spring Hinge

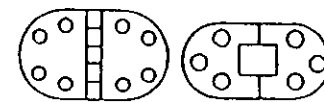

(AA) Platform Hinge (BB) Leaf Hinge

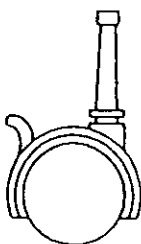

(V) Locking Caster

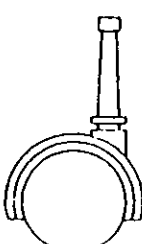

(W) Non-Locking Caster

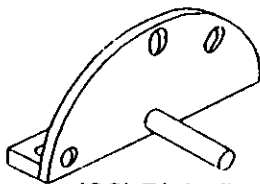

(CC) Right Bracket

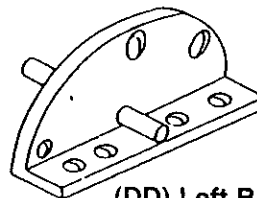

(DD) Left Bracket

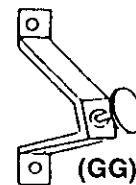

(GG) Platform Stopper

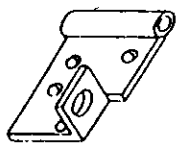

(EE) Left Hinge

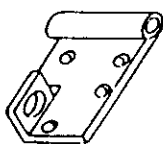

(FF) Right Hinge

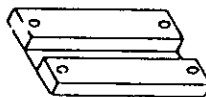

(II) Drawer Back

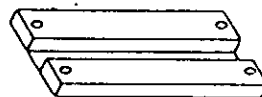

(JJ) Drawer Side

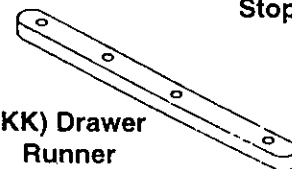

(KK) Drawer Runner

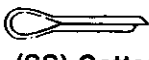

(SS) Cotter Pin

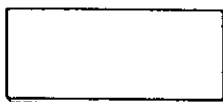

(MM) Drawer Bottom



(NN) Front Hinge

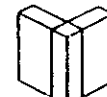

(QQ) Drawer Connector



(RR) Mechanism Spring

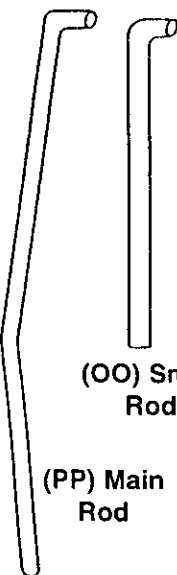

(OO) Small Rod

(PP) Main Rod



(LL) Drawer Clip

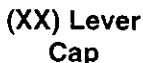

(XX) Lever Cap

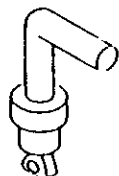

(YY) Release Lever

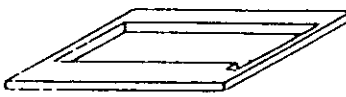

(TT) Sewing Insert

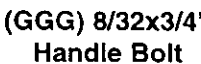

(GGG) 8/32x3/4" Handle Bolt



(UU) Adjustment Screw



(VV) Pivot

(FFF) Self Sticking Rubber Tab



(ZZ) Plastic Spacer



(WW) 1/4"-20 Hex Nut

(HH) 2 PC. Knob Metal (98200)

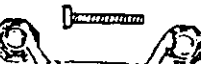

(AAA) Handle (98200 only)

98201

(DDD) #6x1" Panhead Screw



(BBB) Platform Tab

(EEE) 8/32x1" Knob Bolt 98200

Other Parts List and Numbers

Ref. No.	Description	Part No.
A	19mm Cam	000709
B	Connecting Bolts	002892
C	Rubber Bumpers	002466
D	Mounting Bolts	002890
E	Zinc Flat Washers	000220
F	Wing Nut	000488
G	Round Magnet	002854
H	Leaf Support Hinge	002734
I	Bronze Strike Washer	000839
J	Plastic Tray	003146
K	#8x1/2" Panhead Screw	002614
L	7/8" Bolt, Ceramic Knob	000185
M	#8x5/8" Ant Brass FH	002570
N	#5x1/2" Flathead Screw	000916
O	1-1/2" Wood Screw	001222
Q	Allen Key	000712
R	Handle (98201 only) Plastic	003145
S	1/4" x 1-1/4" Wood Dowel	002549
T	3/4" Caster Clip	000324
U	Caster Insert	000368
V	Locking Caster	001135
W	Non-Locking Caster	001136
X	Front Support	002547
Y	#6x1" Flathead Screw	001325
Z	Spring Hinge	000264

Ref. No.	Description	Part No.
AA	Platform Hinge	002553
BB	Leaf Hinge	002733
CC	Bracket Right	000151
DD	Bracket Left	000150
EE	Hinge Left	000152
FF	Hinge Right	000153
GG	Platform Stopper	000157
HH	Knob (#98200 only) Metal	003170
HH	Knob (#98201 only) White Ceramic	003165
II	Drawer Back	003141
JJ	Drawer Side	003140
KK	Drawer Runner	002397
LL	Drawer Clip	003138
MM	Drawer Bottom	003160
NN	Front Hinge	002551
OO	Small Rod	000155
PP	Main Rod	000154
QQ	Drawer Connector	003142
RR	Mechanism Spring	000166
SS	Cotter Pin	000163
TT	Sewing Insert (98200 only)	003159
TT	Sewing Insert (98201 only)	002644
UU	Adjustment Screw	000159
VV	Pivot	000156
WW	1/4" x 20 Hex Nut	000158
XX	Lever Cap	000165
YY	Release Lever	000164
ZZ	Release Spacer	000167
ZZZ	#6x5/8" Brass Panhead	000083
AAA	Handle (98200 only) Metal	003169
BBB	Platform Tab	000086
CCC	Manual	003148A
DDD	#6x1" Panhead Screw (Plastic Handle)	003177
EEE	8/32x1" Metal Knob Bolt	003192
FFF	Self Sticking Rubber Tab	003174
GGG	8/32x3/4" Metal Handle Bolt	003191
HHH	#8x5/8" FH-ZN/ Yellow Leaf Screw	003173

API Specialty Furniture

(A Division of ARROW PRODUCTS, Inc.)

P.O. Box 410, Elkhorn, WI 53121

1-800-533-7347

09-99

**98200-BC
98201-BC**