

SEWING MACHINE CABINET

OWNER'S MANUAL

Model Number 272.98300.490 Oak
272.98301.490 White
272.98302.490 Cherry

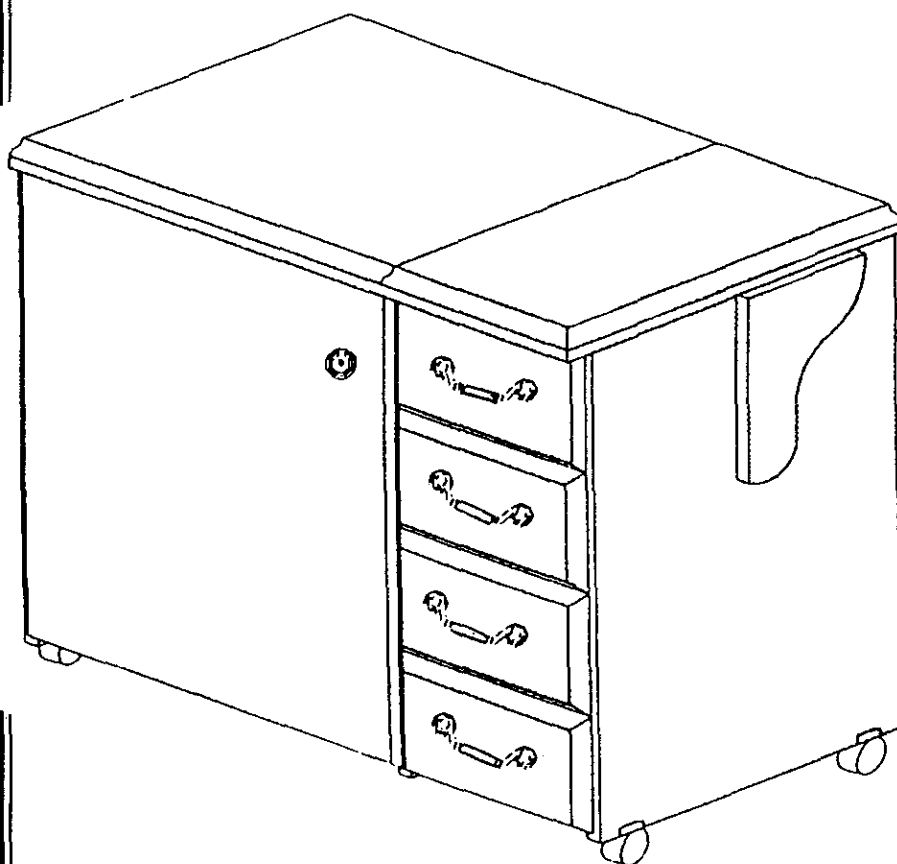

- ASSEMBLY
- PARTS LIST

IMPORTANT:
Read instructions before assembling.

98300-FC
98301-FC
98302-FC

Hardware Included

(20) #8x1/2" Panhead Screws

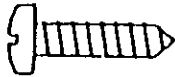

(2) #6x5/8" Panhead Screws



(9) #5x1/2" Flathead Screws

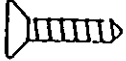

(32) #6x1" Flathead Screws

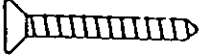

(16) #8x5/8" Flathead Screws
Bronze



(1) 7/8" Bolt



(8) #6x1" Panhead Handle
Screws

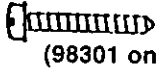

(8) 6mm Hex Nuts



(8) Washers



(3) Non-locking
Casters

(2) Locking
Casters

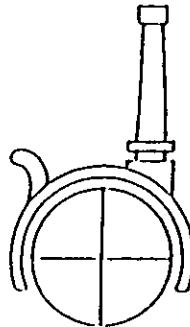
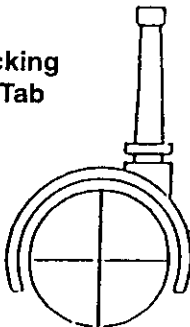

(8) 6mm Hex Bolt

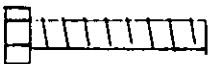

(2) Self Sticking
Rubber Tab



(2) Mounting Bolts



(2) Wing Nuts



(2) Zinc Flat Washers



(5) Caster Clips

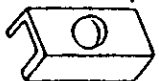

(5) Caster Insert

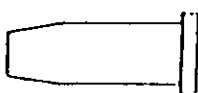

(25) Connecting Bolts

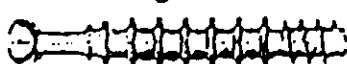

(8) Drawer Sides

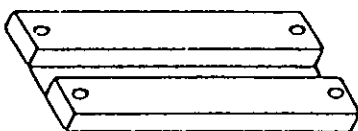

(4) Metal Handle
98300
98302



(25) Cams

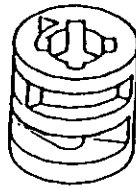

(6) #5x5/8" Flathead
Screws



(1) 2 pc. Knob

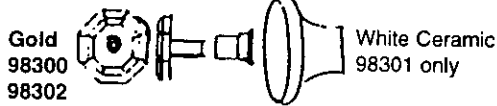

(4) Support Hinge

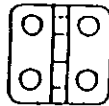

(1) Custom
Fit Insert
Hook



(16) Drawer Connectors

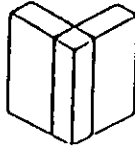

(1) Right Wing

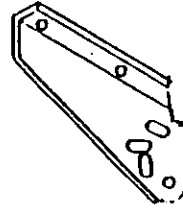

(1) Left Wing

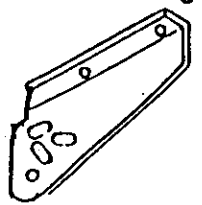

(2) Door Hinge

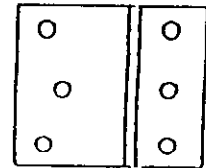

(1) Magnet



(1) Tote Tray

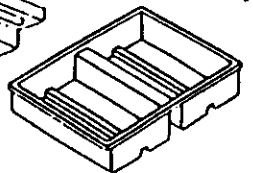

(8) Drawer Runners

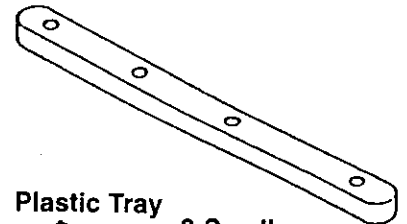

(1) Plastic Tray

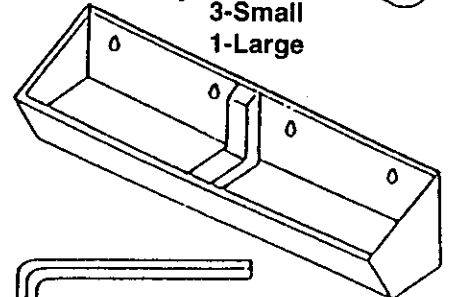

(2) Bronze Strike Washers



(4) Drawer Backs

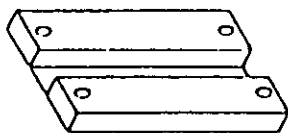

(4) White Plastic Pulls
98301 only

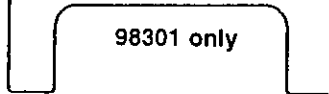

(1) Allen Key

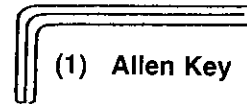

(1) Strike Plate



(2) Round Magnet



(1) Lift Mechanism

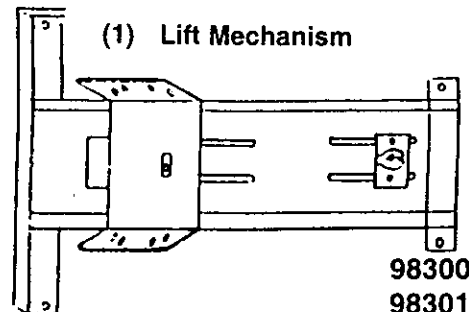

98300-2
98301-2
98302-2

Understanding How the "ARROW-LOC" Cam Fastener Works.

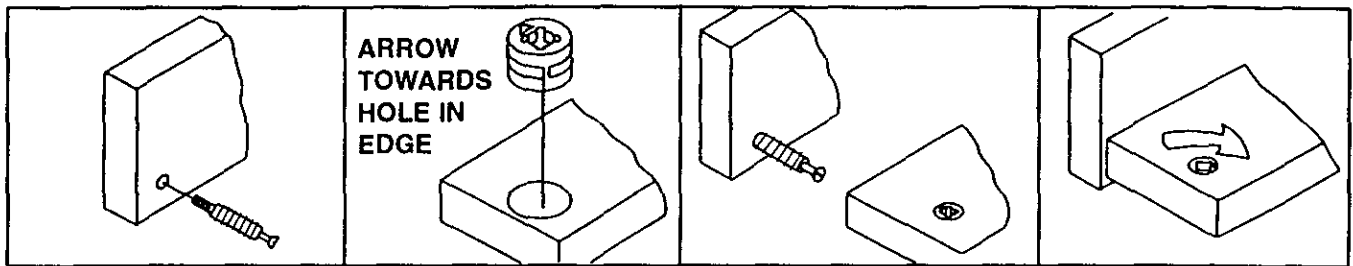

1. Position bolt in pre-drilled hole and turn until tight.
2. Press cam into pre-drilled hole until flush with surface.
3. Insert bolt through pre-drilled hole in edge of panel.
4. To lock, rotate cam until tight, using allen key provided.

Cabinet Assembly

Step 1. Place Top, Partition and Left and Right Sides on a flat protected surface (to prevent scratching of parts) and thread connecting bolts (25 total) into pre-drilled holes (as shown in FIG. 1). Turn Partition over and thread in the remaining bolts as indicated below (FIG. 1A).

NOTE:

● = Connecting Bolt

FIG. 1

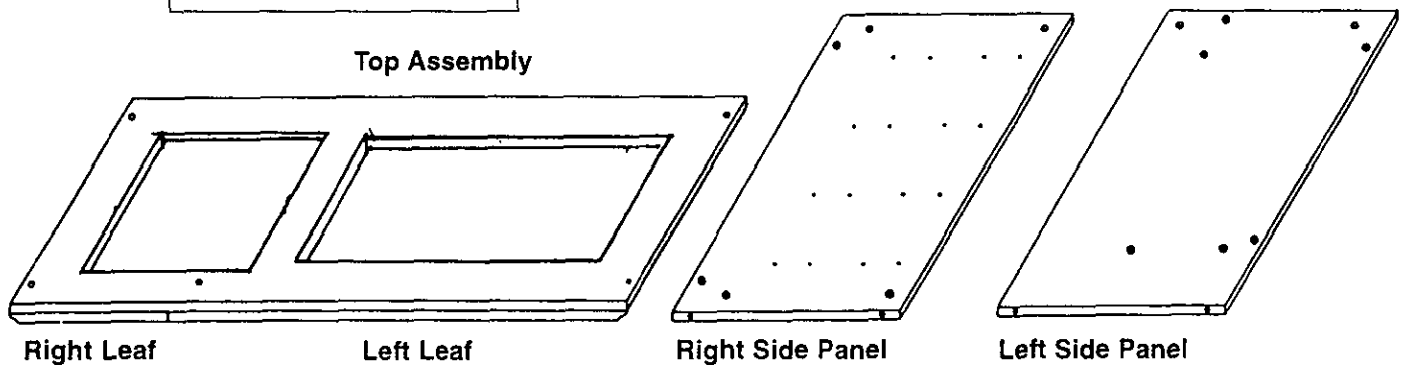
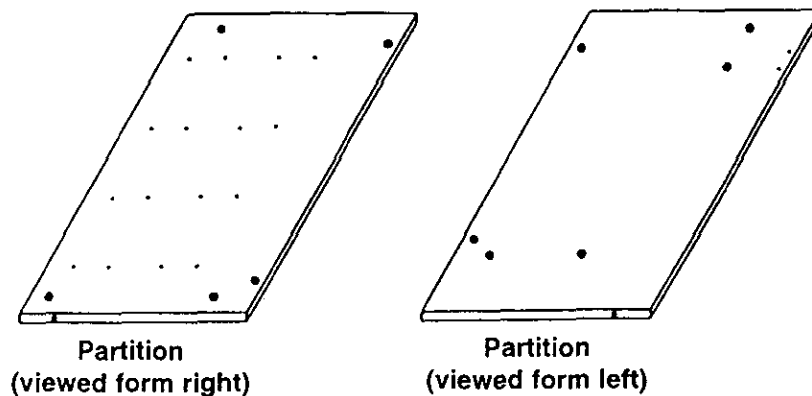

FIG. 1A



98300-3
98301-3
98302-3

Cabinet Assembly Continued:

Step 2. Install Cams (25 total) into the holes provided in the cabinet parts shown below, pushing a cam into each hole until flush with the surface. The arrow on the Cams should be turned (using a regular screwdriver or Allen Key Provided) to face the hole in each edge where the Connecting Bolts will enter.

Step 2A. We are providing (1) white plastic hook to be used, to store your custom fit sewing head insert, (Sears #9801) to be mounted on the inside left side panel in Hole (A) or (B). **CAUTION** Do not attach hook until you know the cutout size of your insert. Use Hole (A) for cutout 3" or less & (B) for cutout larger than 3".

NOTE:
☉ = Cam

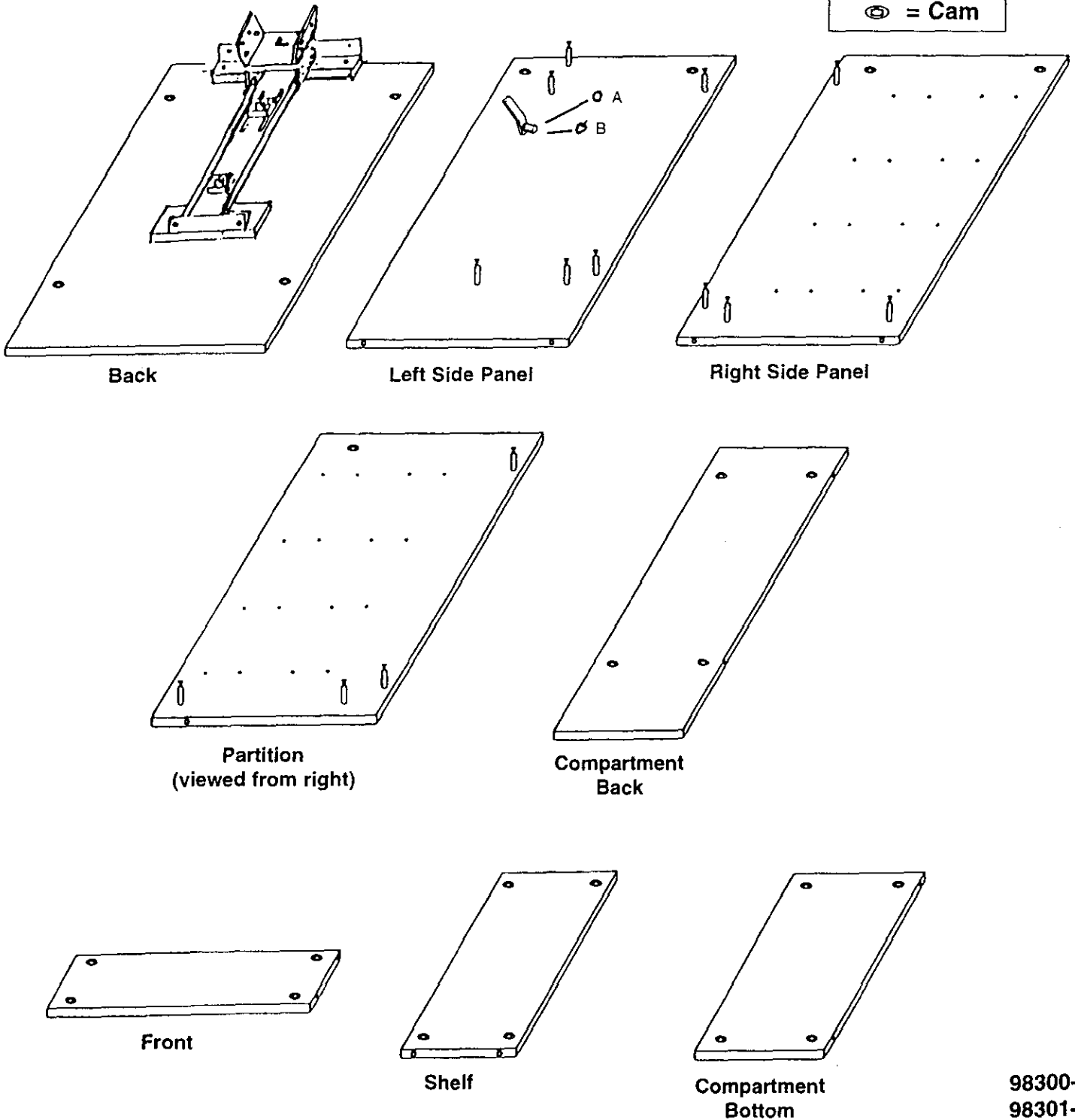

Step 3. Attach the Magnet to the Partition by using (2) #6x5/8" Screws. Be sure to keep the magnet Strikes (metal) facing towards the front edge of the Partition (as shown in FIG. 2.)

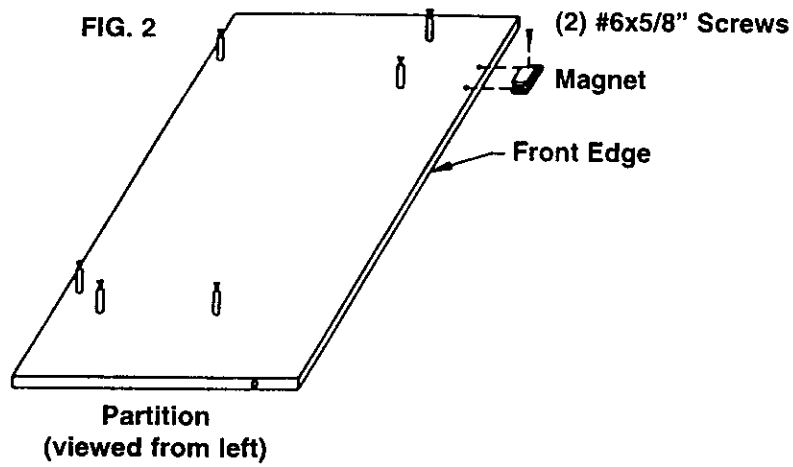

Step 4. Next, attach the plastic Drawer Runners by using (32) #6x1" Flathead Screws (as shown in FIG. 4). DO NOT OVER TIGHTEN.

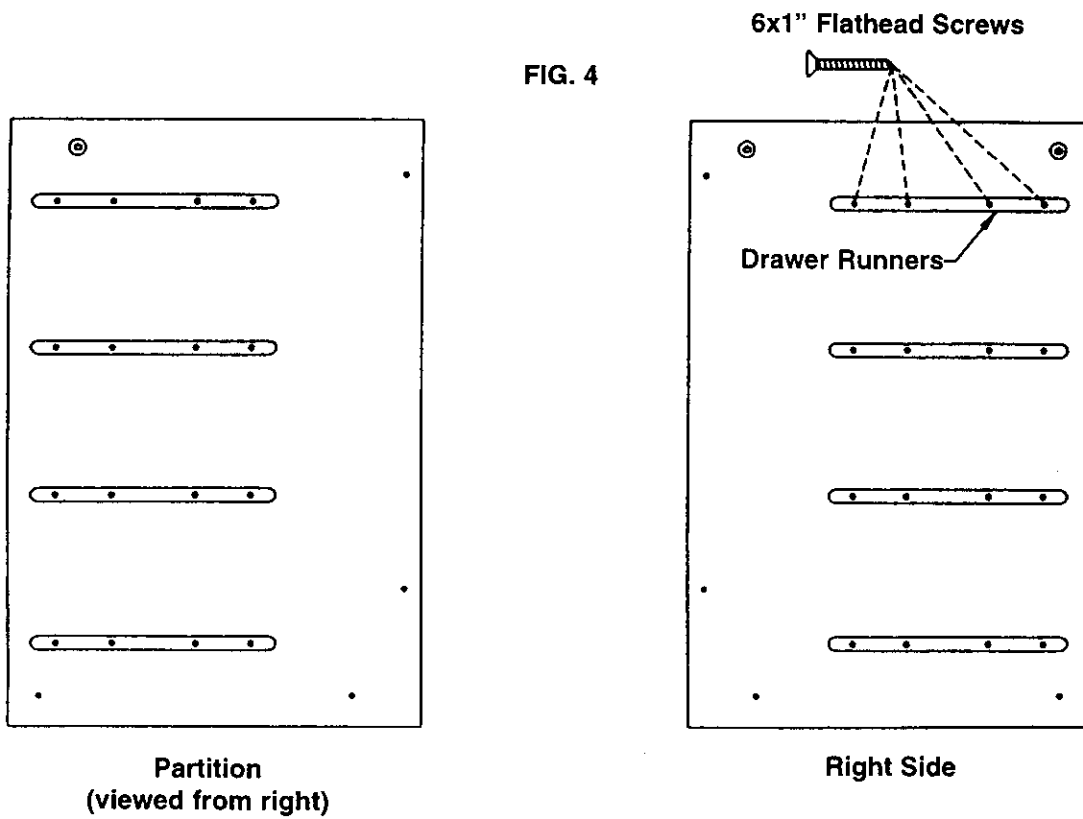

Step 5. Attach the Left and Right Wings to the Platform using (4) #8x1/2" Panhead Screws (as shown in FIG. 5). The long flanges facing outward and toward edge of Platform.

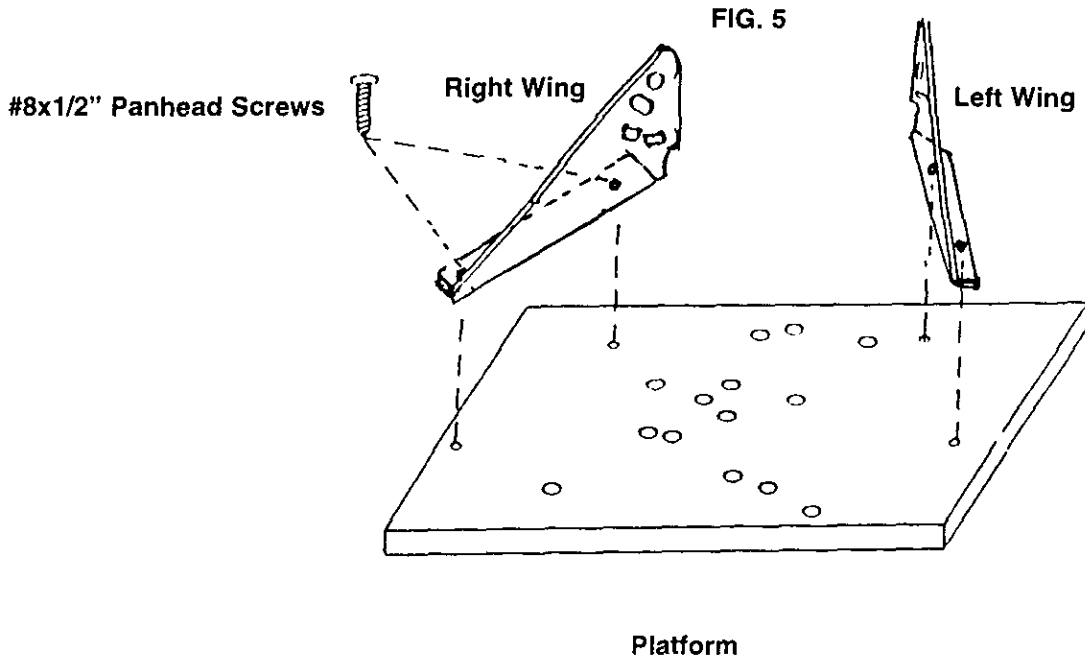

Step 6. Attach the Wings (with Platform) to the Carriage of the Lift Mechanism by laying the Back (with Lift attached) in a flat position and aligning the top and bottom holes in Wing flanges with the holes in the Lift Carriage. Insert the (8) 6mm Hex Head Bolts through the Wings and Carriage and attach a Washer & Hex Nut to each Bolt (as shown in FIG. 6). Before tightening the Nuts and Bolts using a 10mm wrench or adjustable wrench or pliers, use a square or the bottom shelf of cabinet to square the platform with the back (as shown in FIG. 6B). Final assembly should look like FIG. 6A.

FIG. 6A

FIG. 6

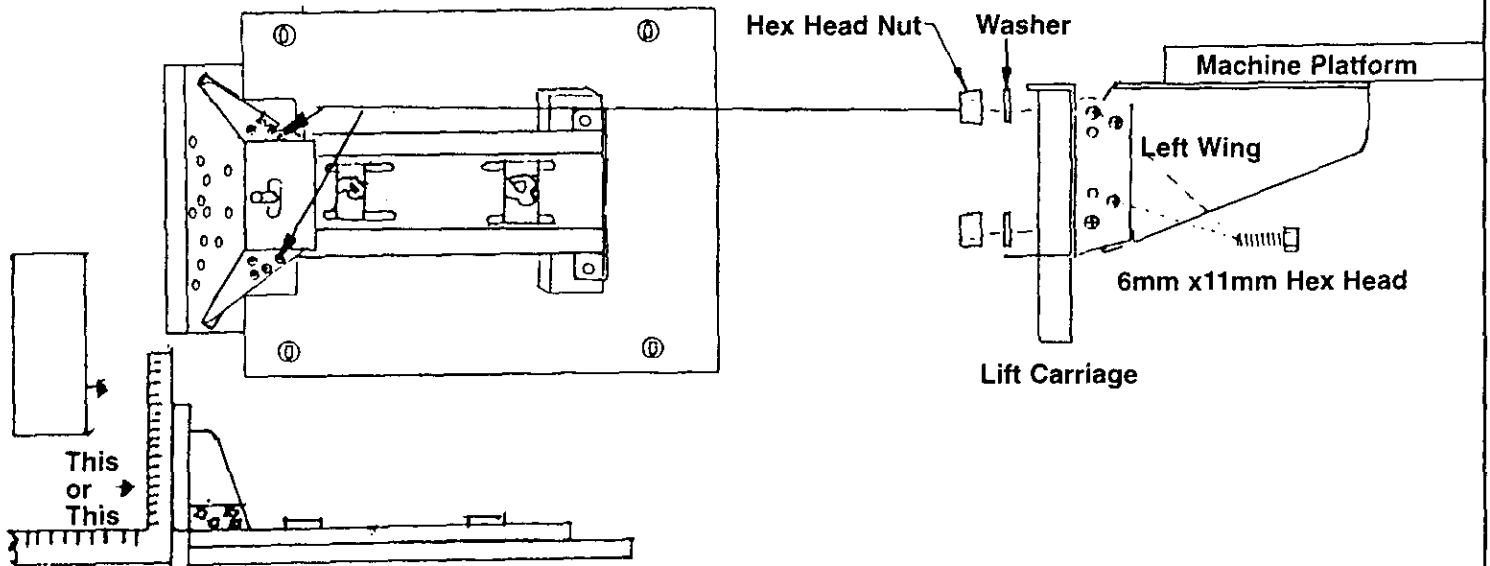
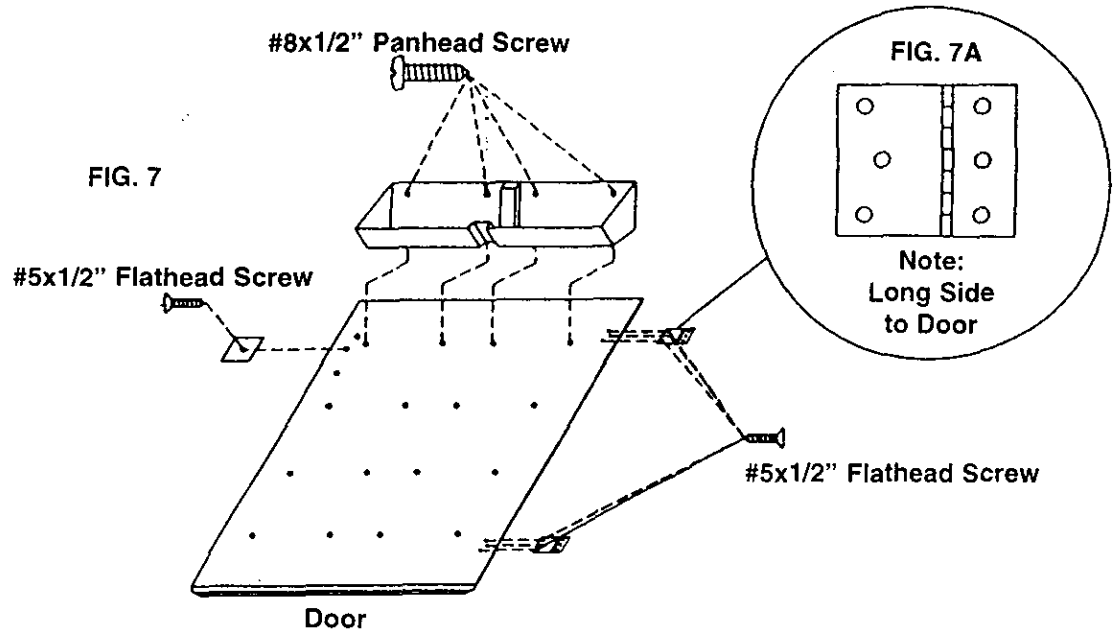

FIG. 6B

Step 7. Attach the (4) plastic Trays to the Door by inserting the (16) #8x1/2" Panhead Screws into the Door. The (3) smaller trays are mounted in the three top rows of predrilled holes, with larger tray mounted in bottom row. Attach Magnet Strike Plate with (1) #5x1/2" Flathead Screw. Attach (2) door hinges to Door with (6) #5x1/2" Screws (as shown in FIGS. 7 AND 7A). Long end attaches to door.



Step 8. Attach (4) Support Hinges to Left and Right Supports with (8) #8x5/8" Flathead Screws; insert (2) Round Magnets into holes in Leaf Supports (as shown in FIG. 8).

Step 8A. Attach Self-Sticking rubber tabs to outer edge of each leaf support.

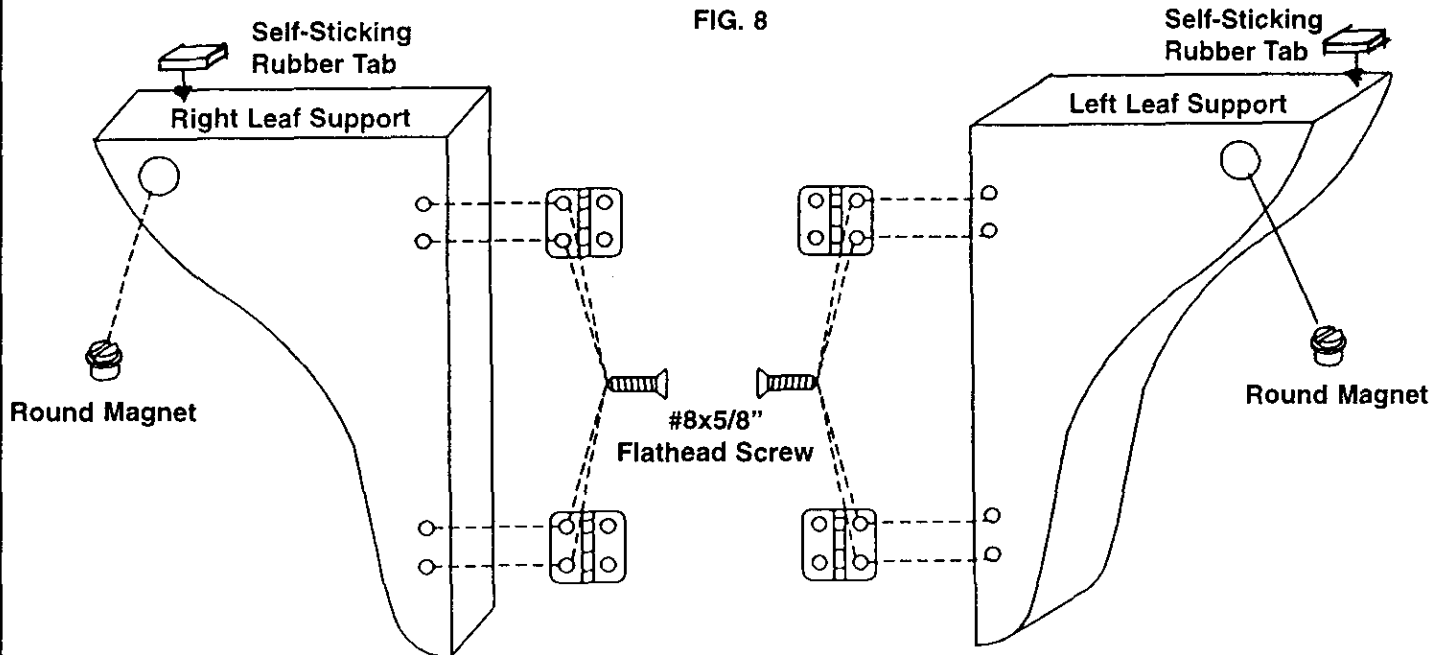

Step 9. Place or tap Caster Clips, Inserts, (1) Locking Caster, and (1) Non-Locking Caster into Left Side (as shown in FIG. 9 below). Attach the back to Left Side by guiding Back onto Connecting Bolts in Left Side (as shown in FIG. 9), turn Cams to the Locked Position. Attach the Shelf and Front by guiding each piece onto the appropriate Bolts in the side, and turn the Cams to the Locked Position.

FIG. 9

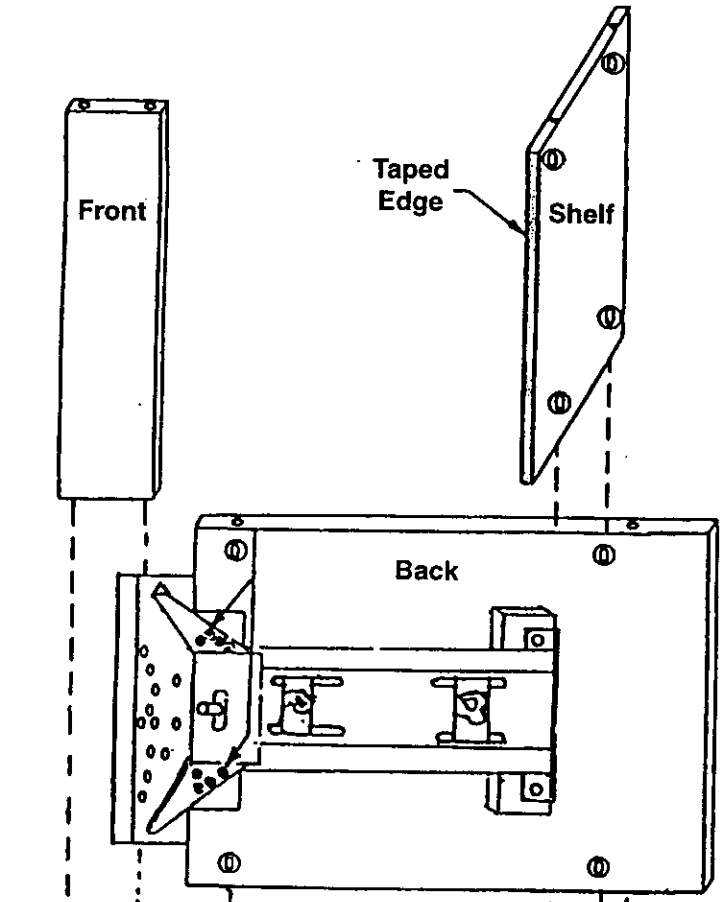
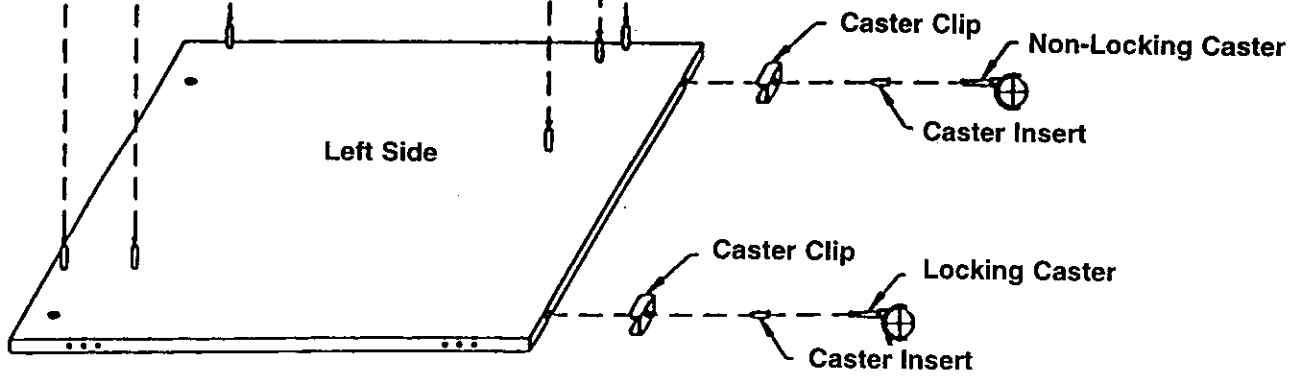

FIG. 9A



98300-8
98301-8
98302-8

Step 10. Place or tap Caster Clip, Insert and Non-Locking Caster into the Partition (as shown in Fig. 10. below). Align the Connecting Bolts in Partition with corresponding holes in Front, Shelf and Back. Now, making sure the Partition is completely on the Connecting Bolts, turn Cams to Locked Position.

FIG. 10

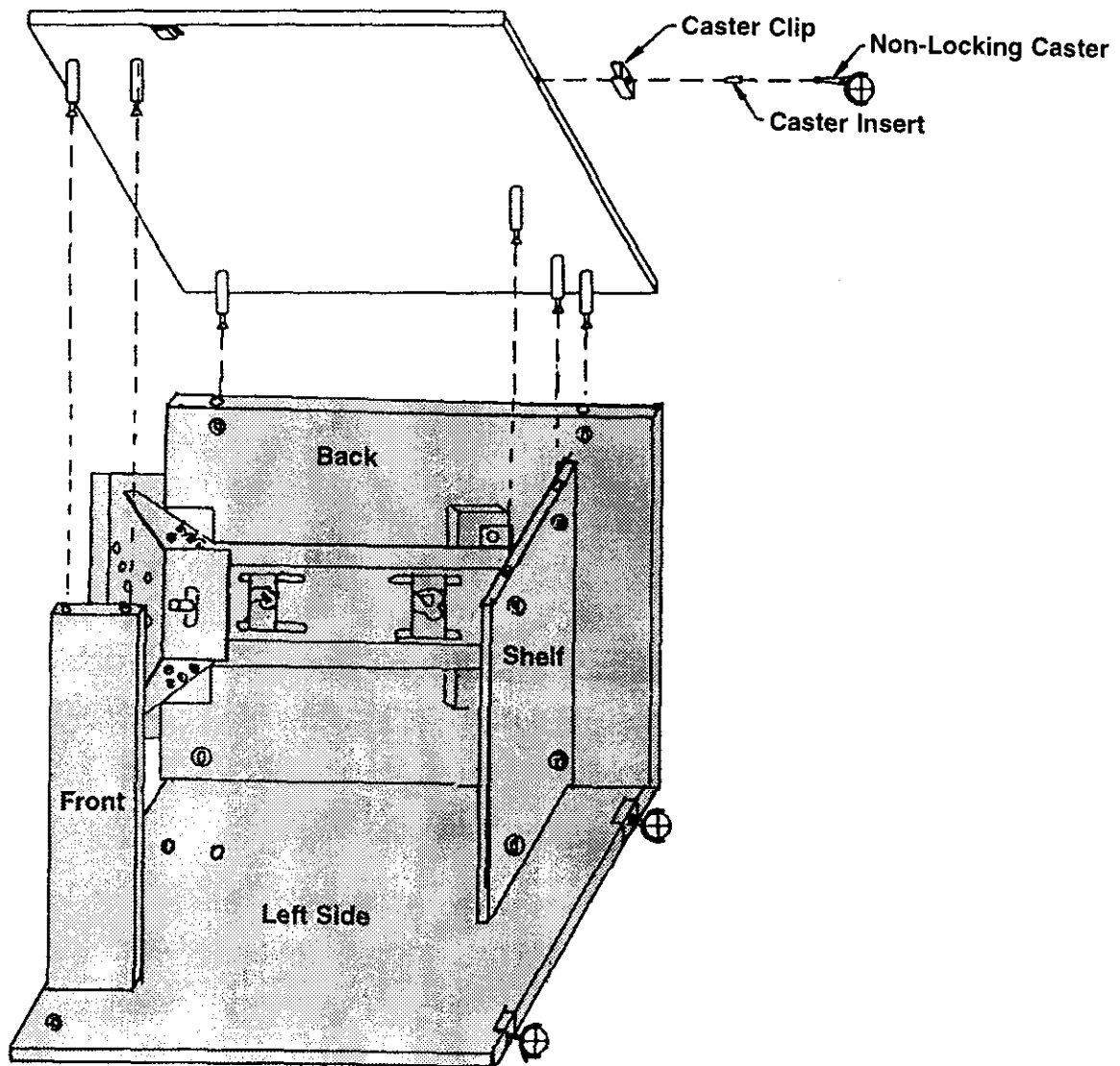

Step 11. Attach Compartment Bottom and Compartment Back to Partition by guiding each piece onto Connecting Bolts in the Partition (as shown in FIG. 11). Turn Cams to Locked Position.

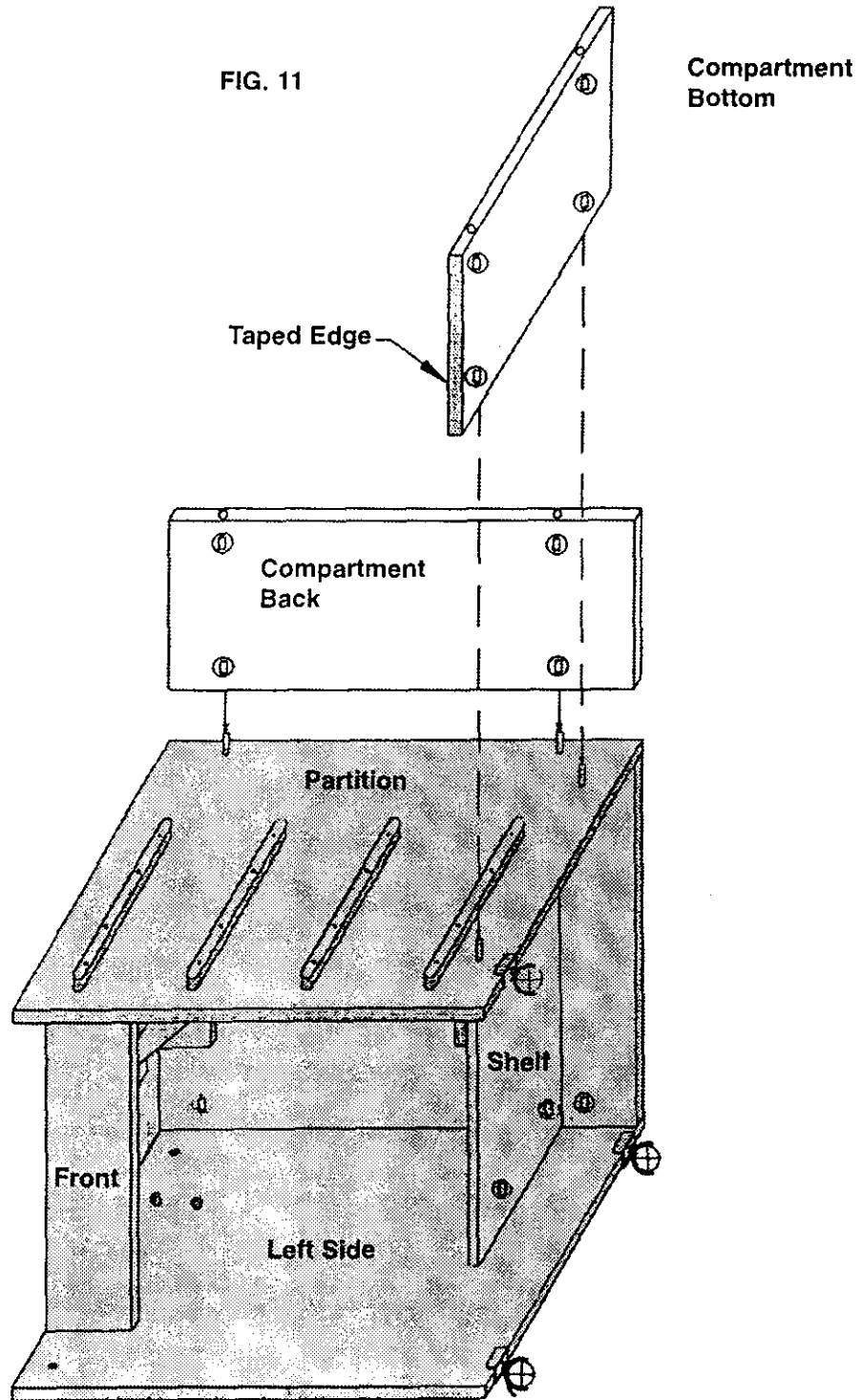

Step 12. Place or tap Caster Clips, Inserts, (1) Locking Caster, and (1) Non-Locking Caster into Right Side (as shown in FIG. 12A below). Attach Right Side by Aligning the Connecting Bolts in the Right Side to the holes in the Compartment Back and the Compartment Bottom (as shown in FIG.12). Turn Cams to Locked Position.

After completing Step 12, carefully turn the Cabinet upright onto the Casters

FIG. 12

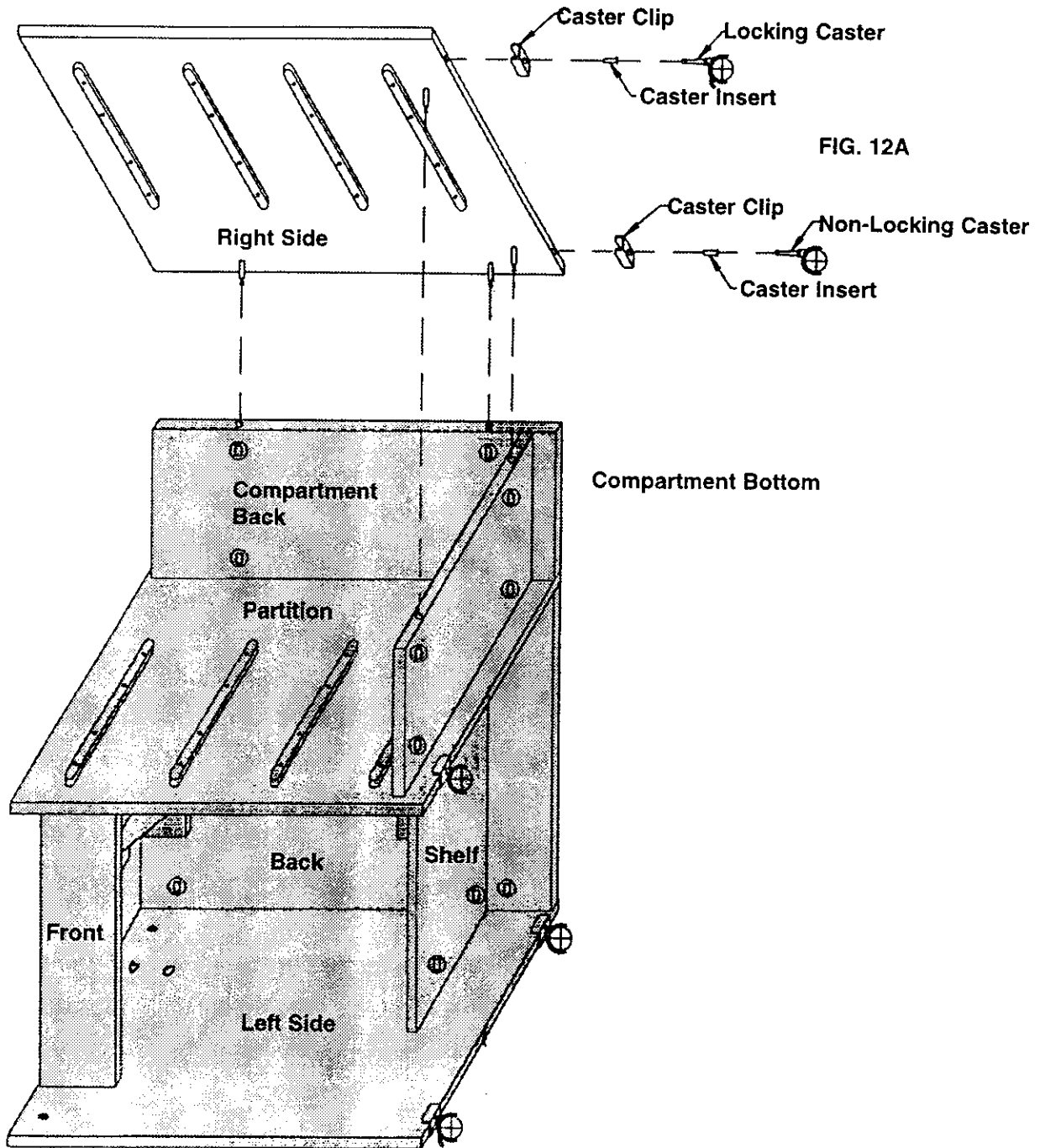

Step 13. Attach the (2) Leaf Support Wings to outside of Right and Left Sides, on right and one Left with (8) #8 x 5/8" Flathead Screws. Now, attach the (2) Bronze Strike Washers for the Round Magnet to each side with (2) #5 x 1/2" Flathead Screws (as shown in FIG. 13).

FIG. 13

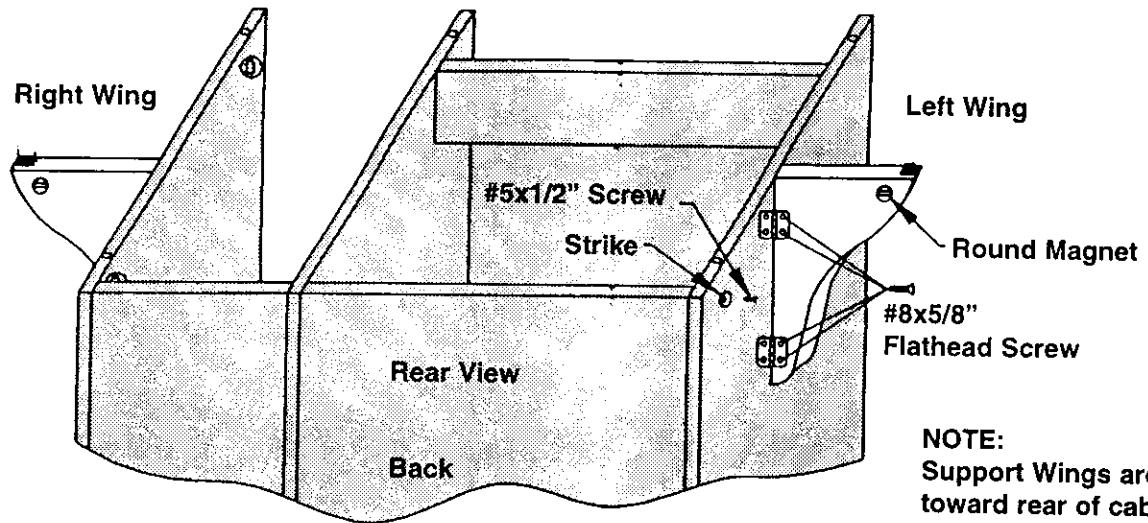

NOTE:
Support Wings are to fold toward rear of cabinet.

Step 14. With an assistant, grasp the Top and Leaves together (top assembly) and turn the Top over and guide the Connecting Bolts into the corresponding holes in the Sides and Partition (as shown FIG. 14). Turn the Cams to the locking position. Some adjustment in the location of the Platform can be made so as to permit Frearm position (see page 15). Just loosen the Screws holding the Platform to the Wings; align and retighten.

FIG. 14

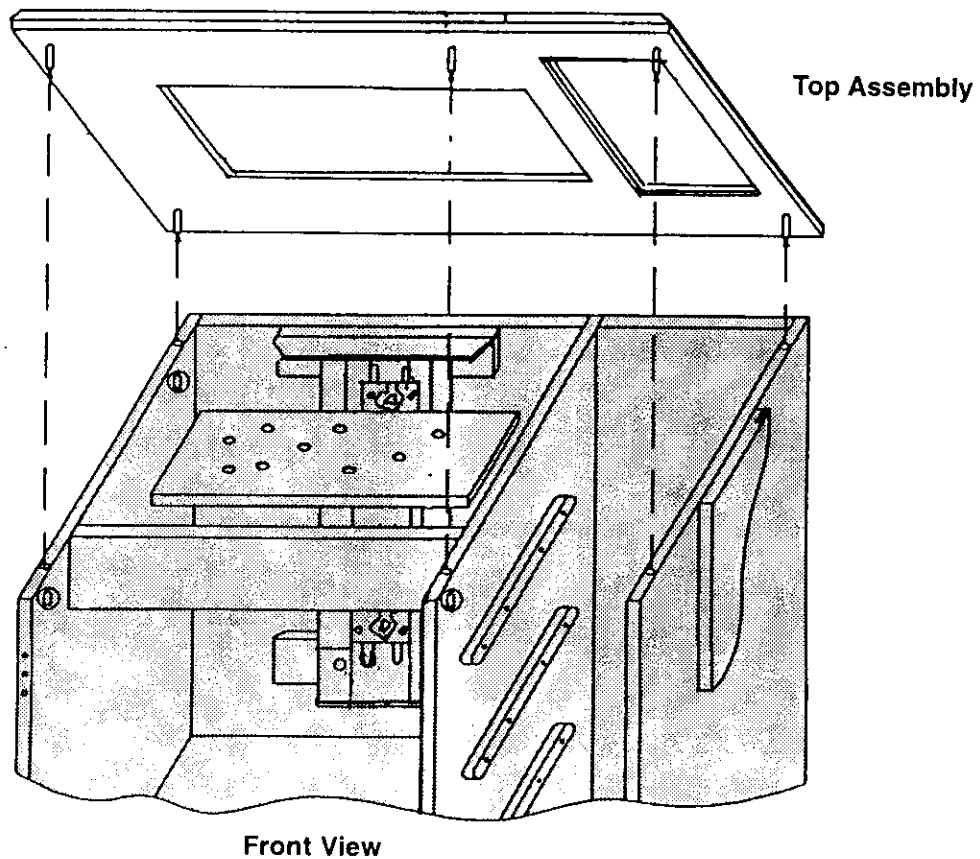

98300-12
98301-12
98302-12

Step 15. The Door may be hung using (6) #5 x 5/8" Flathead Screws (as shown in FIG. 15). Next attach the Door Knob using (1) 7/8" Bolt for Ceramic Knob or (1) 8/32 x 1" Bolt For Metal Knob, this is a 2 pc. Knob Assembly as shown in FIG. 15. A.

White Ceramic Knob
(98301 only)

2 pc. Metal Knob
(98300 + 98302 only)

FIG. 15.A

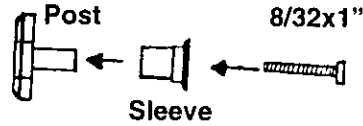
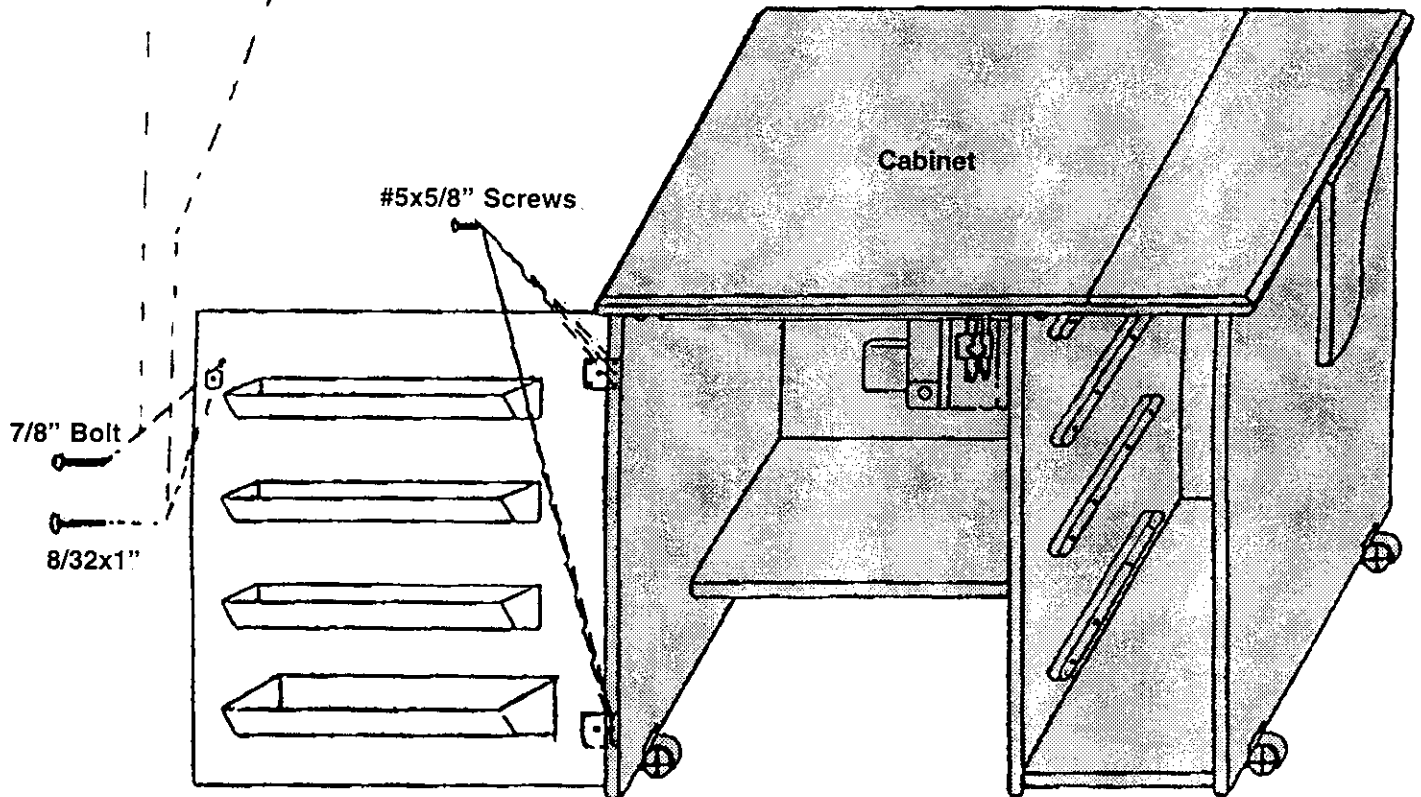

FIG. 15



98300-13
98301-13
98302-13

PLEASE NOTE:

BE SURE TO KEEP GROOVES IN DRAWER PARTS (FOR DRAWER BOTTOM) ALIGNED WHEN ASSEMBLING THE DRAWER.

Assembling the Drawer

Begin Drawer assembly by inserting Drawer Connectors into the ends of the (4) Drawer Backs, (as shown in FIG. A). Push Connectors all the way into the Drawer Backs until the tabs lock into place.

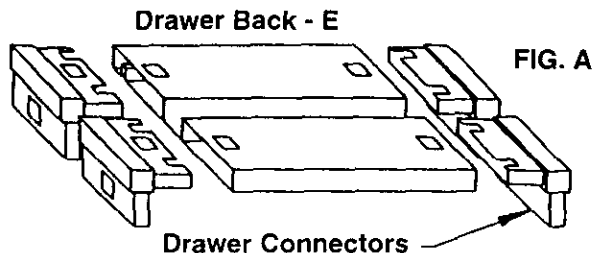
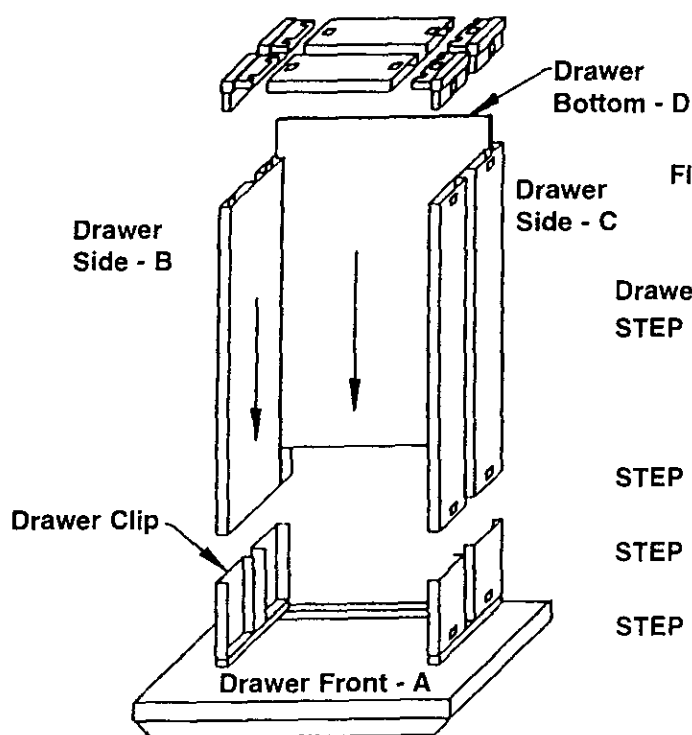

Drawer Assembly

- STEP 1. Attach DRAWER Sides B and C to Drawer Front-A. Align Drawer Bottom grooves in Sides with Drawer Bottom groove in Drawer Front. Snap Drawer Sides onto clips on Drawer Front (see FIG. B).
- STEP 2. Slide Drawer Bottom-D along grooves on the Sides into the groove in Drawer Front.
- STEP 3. Align groove in Back-E with the Drawer Bottom-D and snap Back corner clips into Sides-B and C.
- STEP 4. Attach the Pulls to Molded Drawer Fronts Using (8) #6X1" Screws for White Plastic Pulls or (8) 8/32X3/4" Bolts for Metal Pulls (see Note Below)

The Drawer may now be installed into your cabinet as shown.

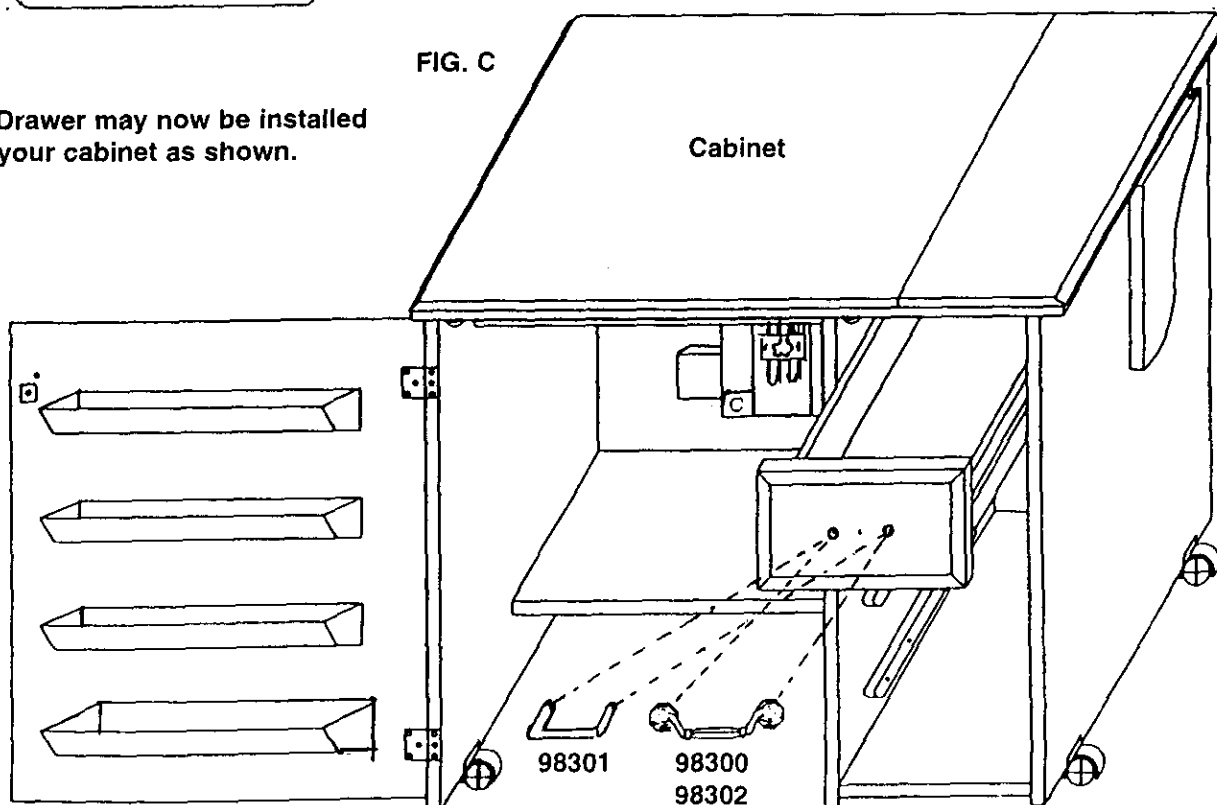

98300-14
98301-14
98302-14

Installing Sewing Machine into Your new Cabinet.

It may be helpful to read the directions for operating the mechanism before proceeding with the following steps. See page 16, and FIG. 19 on next page.

- Step 1.** Swing out the Leaf Support Wings and open leaves. To prevent damage to Cabinet surface, place cushioning material just to the left of cut-out. Lay the machine on its back, on top of cushioning material.
- Step 2.** Take the cord from the foot control up from the bottom through the slot on the right end of the cabinet Platform (see FIG. 16).
- Step 3.** Plug the cord into the right end of the sewing machine (see FIG. 17).

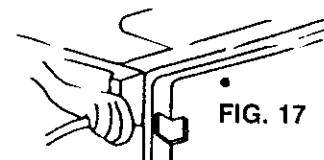
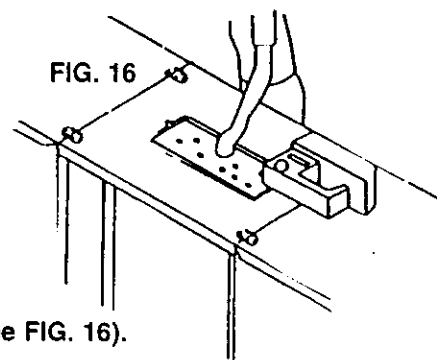

IMPORTANT: Do not place sewing machine too far out onto the Leaf. The extra weight may cause the cabinet to flip over. This could cause personal injury or damage to the cabinet and sewing machine.

Installing Sewing Machine Head

VERY CAREFULLY ATTACH THE SEWING MACHINE TO THE CABINET IN THE FOLLOWING MANNER:

- Step 4.** Remove the extension table on the left side of the sewing machine (Free Arm Position). If it is detachable.
- Step 5.** Thread the (2 provided) Headmounting Bolts into the two threaded holes located on the bottom of your machine; twist tight to the collar. Number and type of Bolts may vary with different machines (see FIG. 18).
- Step 6.** Locate the appropriate platform holes which position your machine in the top opening to allow for use of the CUSTOM FIT plastic insert (Sears Item #9801) when sewing in the flatbed position. See Fig. 18 and Photo C on Page 17. For assistance in locating the appropriate platform holes please refer to FIG. 18B. on page 16.

Next, secure machine to Platform with Washers and Wing Nuts by tightening into place from underneath Platform (see FIG. 18A).

- Step 7.** Lower machine onto the platform, aligning bolts with the holes selected in the platform. Some Machines may require new holes to be drilled.
- Step 8.** Pushing the machine down, lower it into the storage position; lift back into the free-arm position, to check operation.

Refer to operating instructions of the Air Lift Mechanism on page 16.

Maintenance of Cabinet:

Clean as you do your other fine furniture. using a soft cloth and polish.

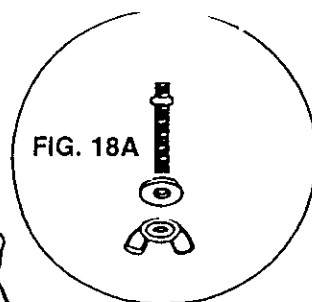

FIG. 18A

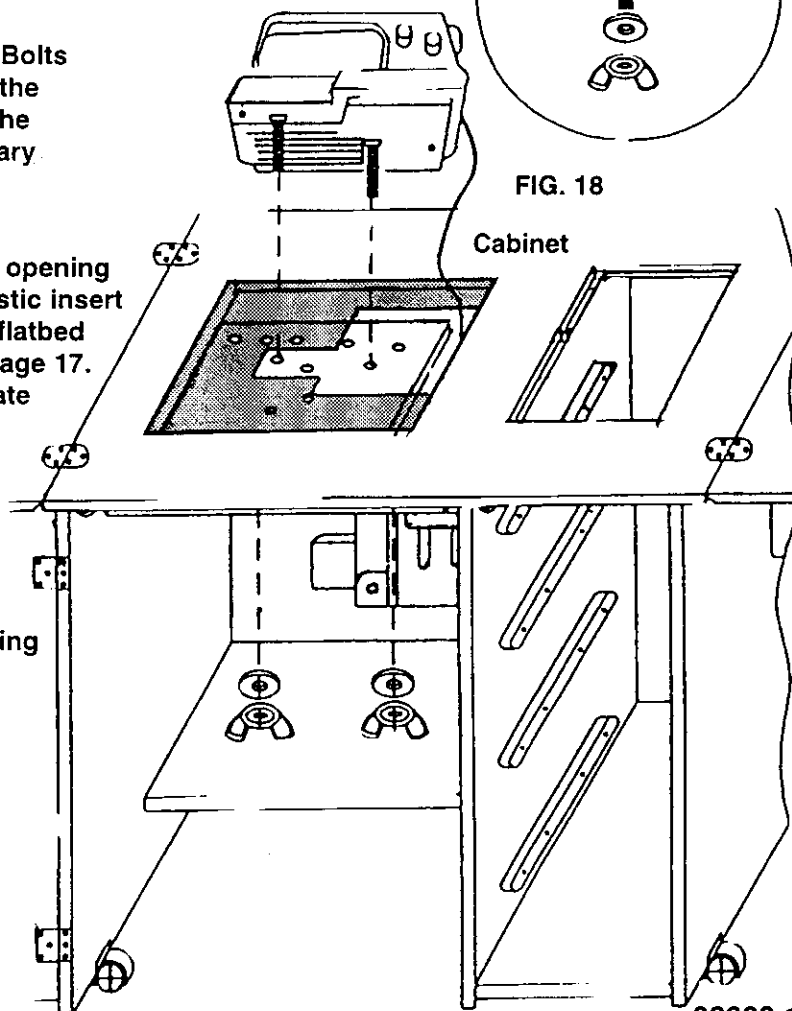
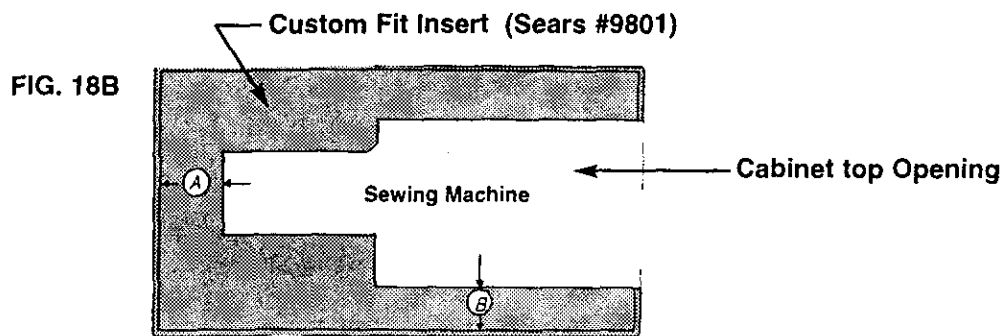

FIG. 18

98300-15
98301-15
98302-15

To assist in selecting the platform holes best suited to properly position your sewing machine, refer to FIG. 18B below.



Determine measurement A & B on your custom-fit plastic insert and select platform holes which will properly place your machine in the cabinet top opening to allow it to fit with the insert when sewing in the flatbed position.

CAUTION:

This cabinet is equipped with a vertical Air-Lift Mechanism which is powered by gas filled cylinder to aid in raising and lowering the sewing machine. PLEASE DO NOT OPERATE THE MECHANISM UNTIL YOU HAVE MOUNTED YOUR SEWING MACHINE ON THE PLATFORM (SEE PAGE 15).

Because gas filled cylinder is heavy duty do not let go of machine and platform when moving from one position to the other.

To move the Platform to any position please follow the instructions on page 17.

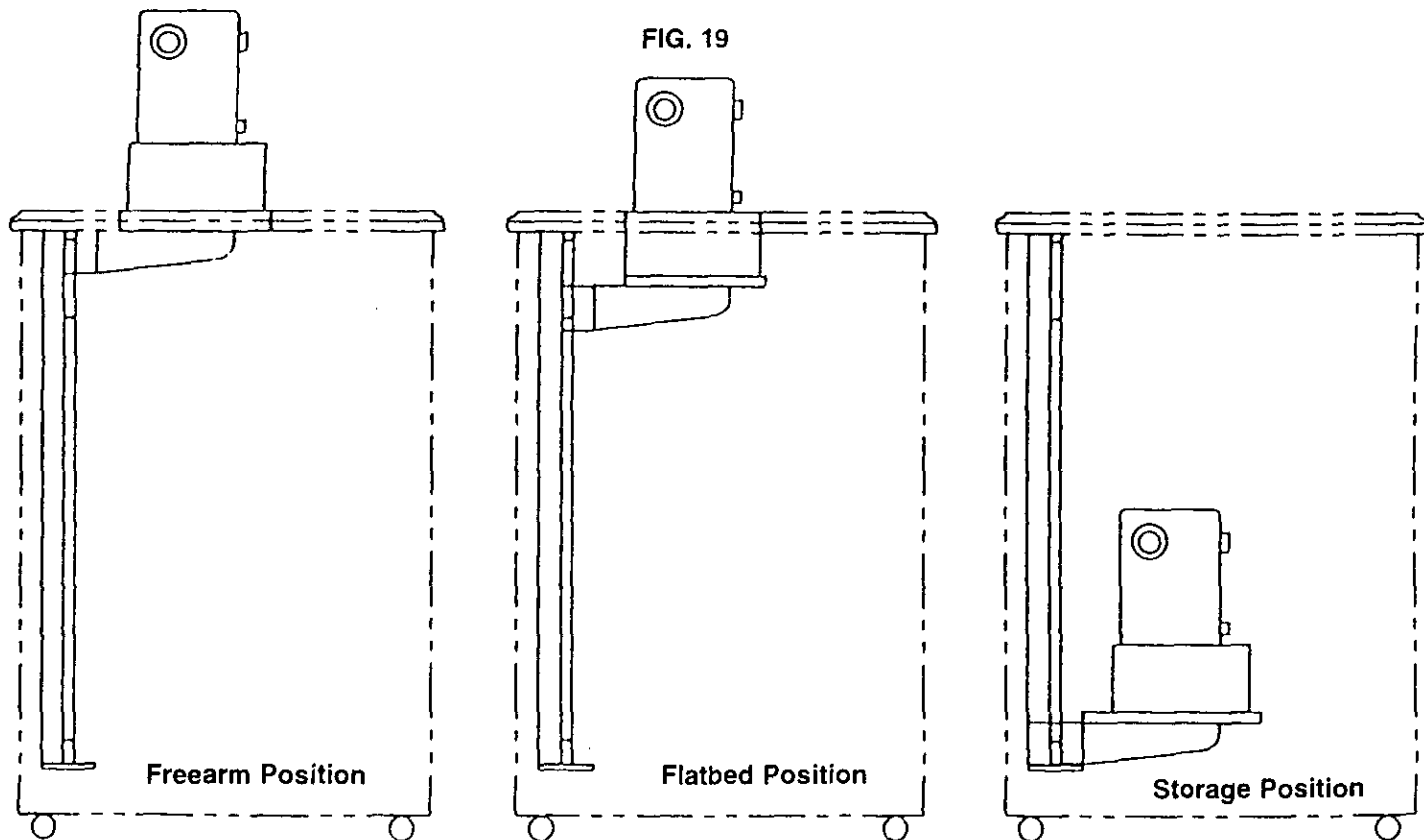

98300-16
98301-16
98302-16

HOW TO MOVE YOUR MACHINE FROM ONE POSITION TO ANOTHER

To move machine from free arm to flatbed (see Photos A, B & C).

GENTLY push down on sewing machine until you hear a "click."

The sewing machine is now locked in place at the flatbed position.

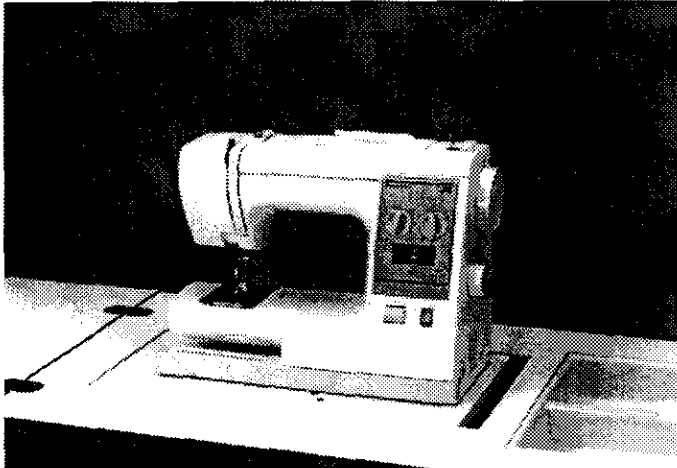

PHOTO A-FREE ARM POSITION

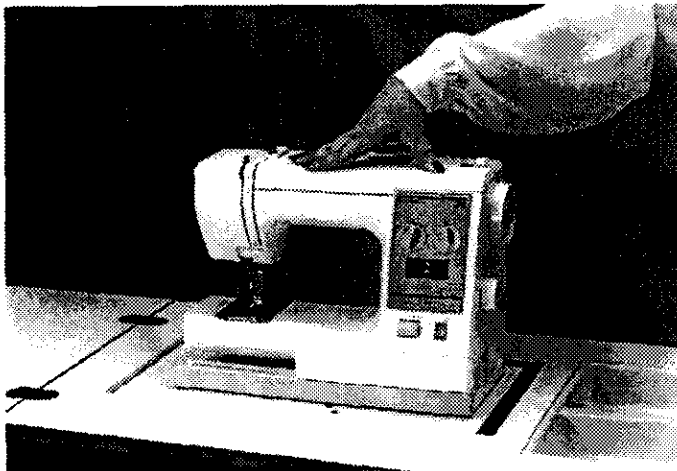

PHOTO B

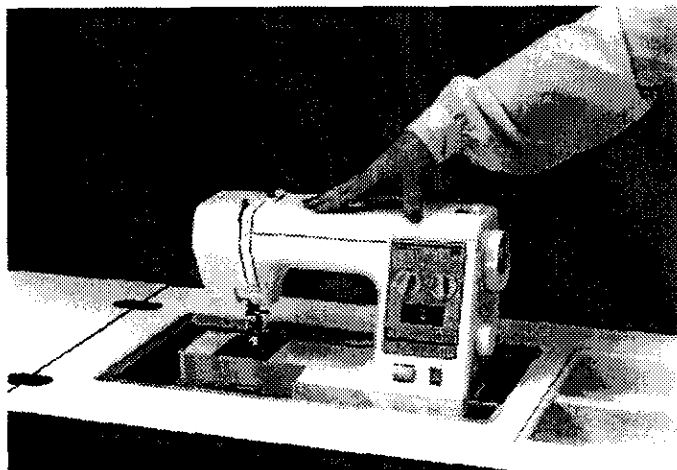

PHOTO C-FLATBED POSITION

To move machine from flatbed to storage (see Photos C,D & E).

GENTLY push down on sewing machine until you hear a "click."

The sewing machine is now locked in place at the storage position.

NOTE: Your mechanism is adjustable. You can adjust up or down by loosening the 2 hex nuts on the cam lock. After moving to the desired position retighten.

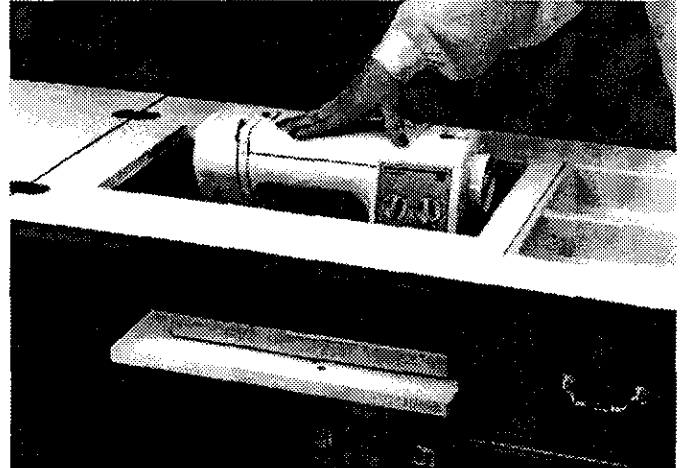
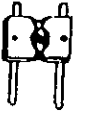

PHOTO D

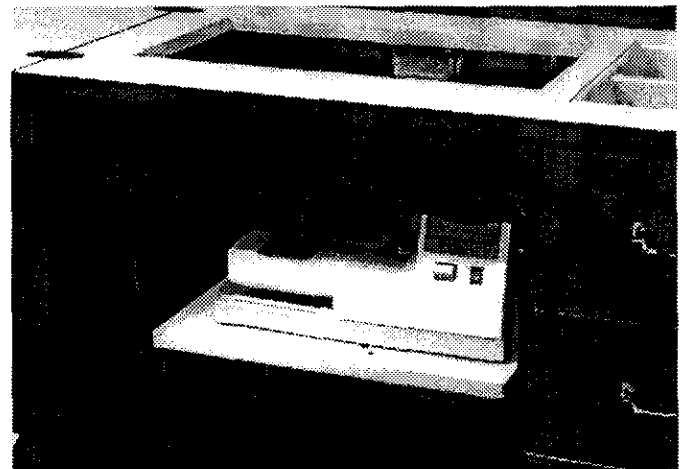

PHOTO E-STORAGE POSITION

To move machine from storage to flatbed (see Photos E & C).

VERY GENTLY push down until you hear a "click" and release.

The sewing machine will now move up to the flatbed position.

To move machine from flatbed to free arm (see Photos C & B).

VERY GENTLY push down until you hear a click and release.

The sewing machine will now move up to the the free arm position. For some machines you may have to lift slightly to lock into the freearm position.

Wood Parts and Part Numbers

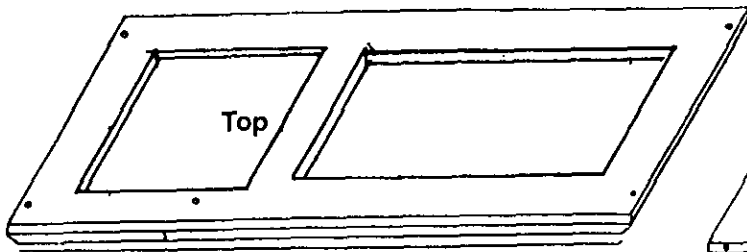

A-Right Leaf

B-Left Leaf

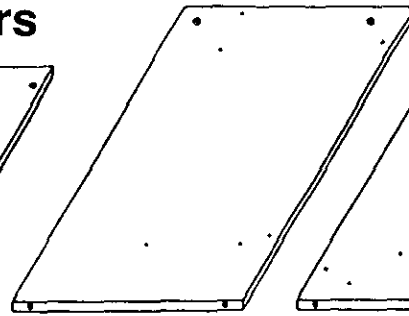

D-Left Side Panel

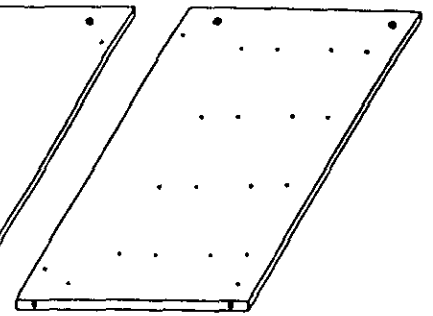

E-Right Side Panel

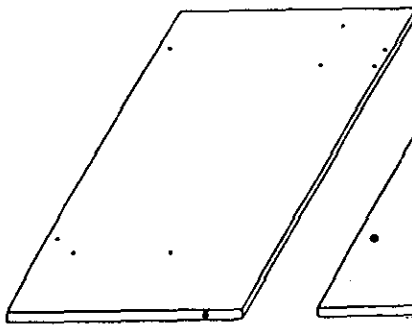

F-Partition
(Left View)

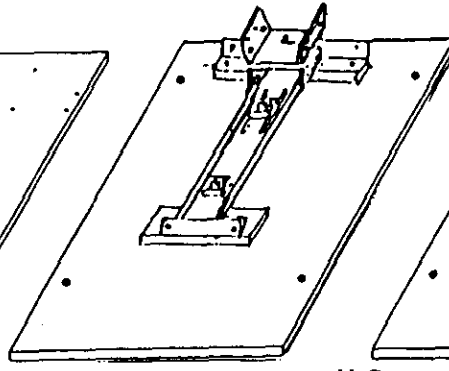

G-Back

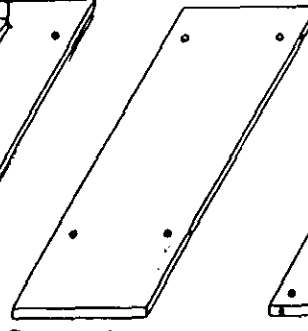

H-Compartment
Back

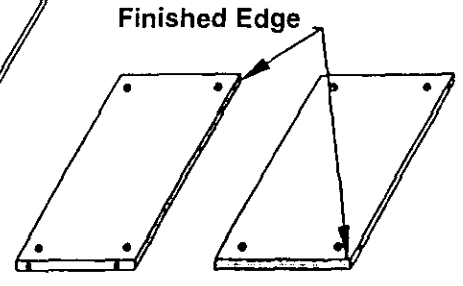

I-Shelf

J-Compartment
Bottom

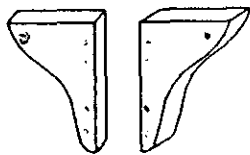

L-Right K-Left
Leaf Supports



M-Platform

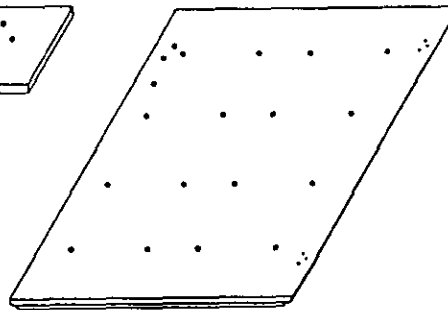

O-Door

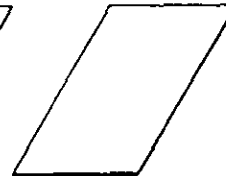

Q-Drawer
Bottom



P-Drawer
Front

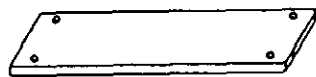

N-Front

Ref. No.	Description	Part No.		
		Oak	White	Cherry
A	Right Leaf	003024	003079	003103
B	Left Leaf	003025	003080	003104
C	Top	003029	003084	003108
D	Left Side	003027	003082	003106
E	Right Side	003026	003081	003105
F	Partition	003028	003083	003107
G	Back	003038	003134	003119
H	Compartment Back	003033	003088	003112
I	Shelf	003030	003085	003109
J	Compartment Bottom	003031	003086	003110
K	Left Leaf Support Wing	003012	003077	003116
L	Right Leaf Support Wing	003023	003078	003117
M	Platform	003037	003133	003118
N	Front	003036	003091	003115
O	Door	003035	003090	003114
P	Drawer Front	003034	003089	003113
Q	Drawer Bottom	003161	003161	003161

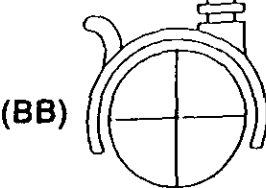
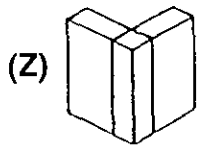
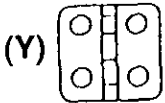
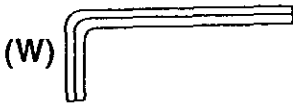
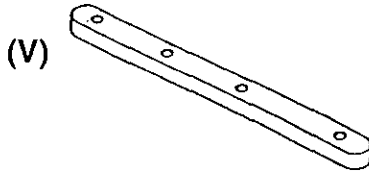
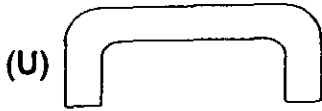
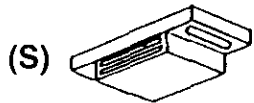
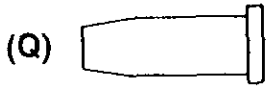
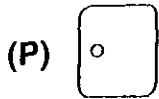
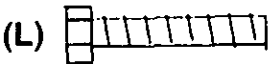
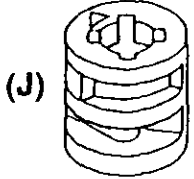
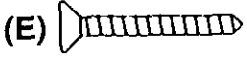
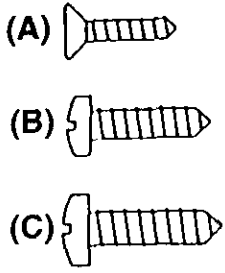

98300-19
98301-19
98302-19

Part Numbers

Ref. No.	Description	Part No.
A	#5x1/2" Flathead Screws	000916
B	#6x5/8" Panhead Screws	000083
C	#8x1/2" Panhead Screws	002614
D	#8x5/8" Flathead Screws Bronze	002570
E	#6x1" Flathead Screws	001325
F	7/8" Knob Bolt (98301)	000185
G	Head Mounting Bolt	002890
H	Wing Nut	000488
I	Zinc Flat Washer	000220
J	19mm Cams	000709
K	Connecting Bolts	002892
L	6mm Hex Head Bolt	003175
M	6mm Hex Nut	003176
N	Round Magnet	002854
O	Bronze Strike Washer	000839
P	Strike Plate	002192
Q	Caster Insert	000368
R	Caster Clip	000324
S	Magnet	001644
T	Handle (#98300-98302 only)	003169
U	Handle (#98301 only)	003145
V	Drawer Runner	002397
W	Allen Key	000712
X	#5x5/8" Flathead Screws	002899
Y	Hinge (Leaf Support)	002734
Z	Drawer Corner Connectors	003142

Ref. No.	Description	Part No.
AA	Knob White Ceramic (#98301 only)	003165
AA	Knob Gold (#98300-98302 only)	003170
BB	Locking Caster	001135
CC	Non-Locking Caster	001136
DD	Right Wing	003193
EE	Left Wing	003194
FF	Plastic Tray	003146
GG	Drawer Side	003140
HH	Drawer Back	003152
II	Lift Mechanism	003167
JJ	Door Hinge	002613
KK	Leaf Hinge	002733
LL	Drawer Front Clip	003138
MM	Large Tray	003158
NN	Tote Tray	002869
OO	#6x1" Panhead Handle Screw (98301)	003177
PP	#8/32x1" Knob Bolt (98300-302)	003192
QQ	Custom Fit Insert Hook	002251
RR	Self Sticking Rubber Tab	003174
SS	6mm Lift-Wing Washer	003190
TT	Manual	003149
UU	#8x5/8" Leaf Hinge Screws Yellow	003270
VV	#8/32x3/4" Metal Handle Bolt (98300-302)	003191

98300-20
98301-20
98302-20

API Specialty Furniture

(A Division of ARROW PRODUCTS, Inc.)

P.O. Box 410, Elkhorn, WI 53121

1-800-533-7347

12-98

98300-BC
98301-BC
98302-BC