

**OWNER'S MANUAL  
SEWING  
MACHINE  
CABINET**

**Model No. 272.98100.491**

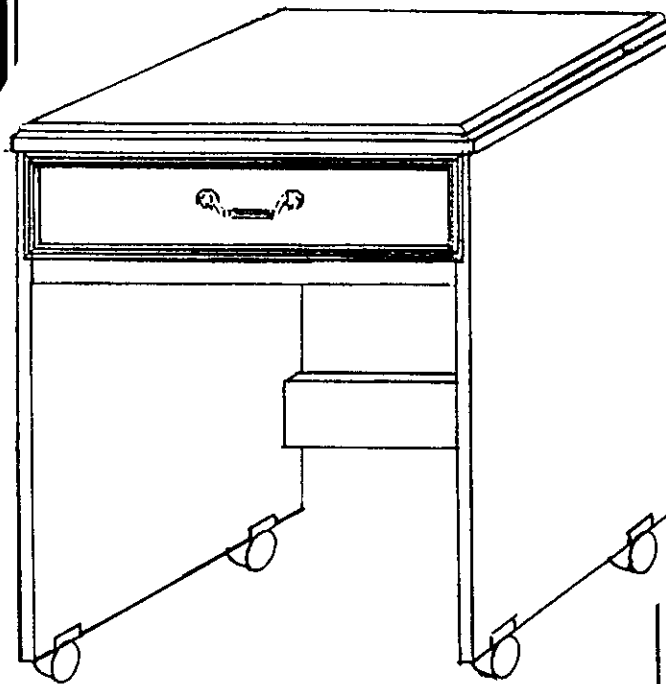

- **ASSEMBLY**
- **PARTS LIST**

**IMPORTANT:**  
Read instructions before assembling.

**Notice to Customer:**

Before beginning assembly, remove all parts from the carton. Check closely with illustrations below to determine that all the parts are included.

For assembly or operating assistance, or to report any missing or damaged parts, you may call or write to:  
**1-800-533-7347**

**Arrow Specialty Furniture**  
 (A division of ARROW Products Inc.)  
 P.O. Box 410, Elkhorn, WI 53121

**TO ORDER REPLACEMENT PARTS CALL 1-800-366-7278**

**MANUALS DE ASAMBLEA EN ESPAÑOL.**

Gracias por comprar su gabinete de costura. Si usted necesita el "Manual en Español" favor de llamar al numero 1-800-533-7347

**PLEASE NOTE:** To assure proper handling of replacement parts please include the following information:

Model Number of Unit - 98100.491

Production ID Number

Number of Parts Required

Your Name, Address, and Phone Number

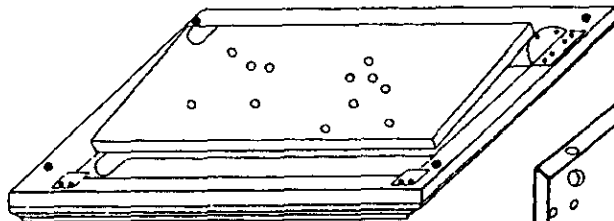

Top Assembly

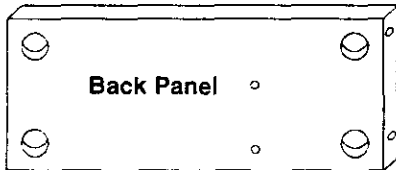

Back Panel



Front/Apron



Back Brace



Front Brace



(6) #8x1/2" PH Screws



(8) #8x5/8" Bronze FH Screws

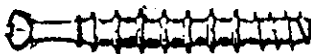

(12) Connecting Bolts

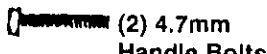

(2) 4.7mm Handle Bolts

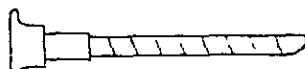

(3) 1-1/2" Screws



(2) Mounting Bolts

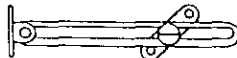

(1) Front Support



(2) Wing Nuts



(2) Zinc Flat Washers



(12) Cams

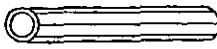

(6) Wood Dowels

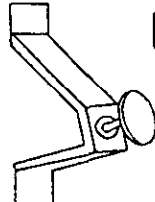

(1) Platform Stopper

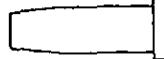

(4) Caster Inserts

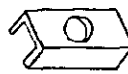

(4) Caster Clips



(1) Handle

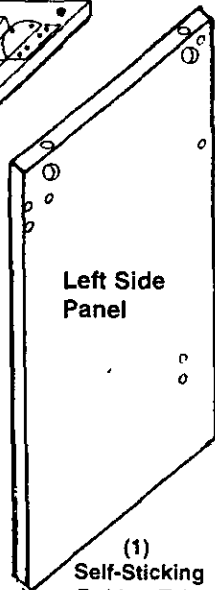

Left Side Panel

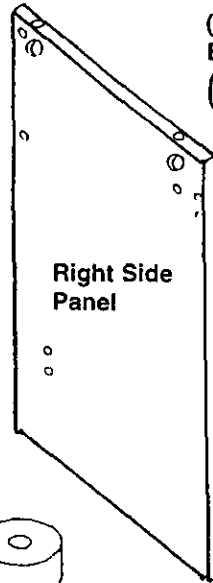

Right Side Panel

(1) Self-Sticking Rubber Tab



(2) Rubber Bumpers

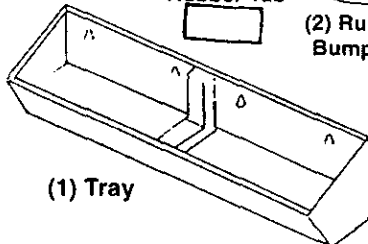

(1) Tray

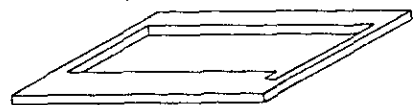

(1) Plastic Insert

(2) #6x5/8" Brass Panhead Screw

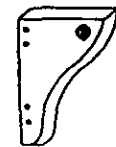

(1) Leaf Support

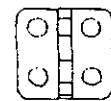

(2) Support Hinge



(5) #5x1/2" Flathead Screw



(1) Bronze Strike Washers

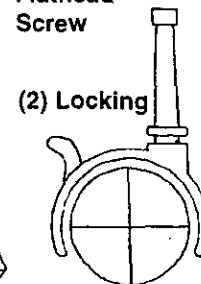

(2) Locking Casters



(2) Non Locking Casters

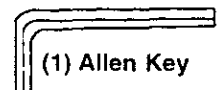

(1) Allen Key

# Understanding How the "ARROW-LOC" Cam Fastener Works

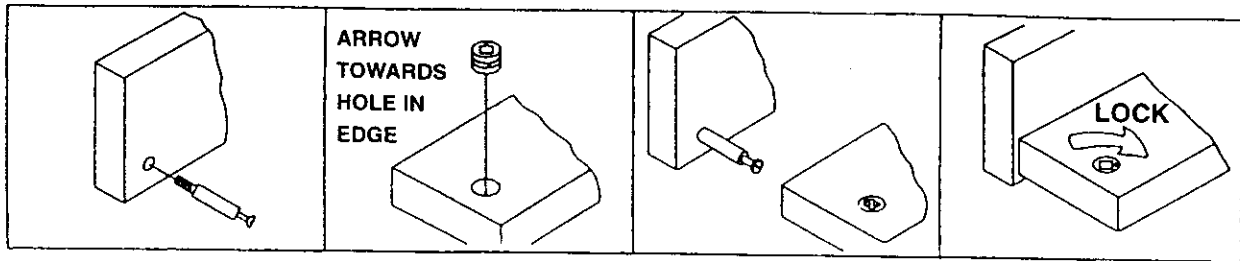

1. Position bolt in pre-drilled hole and turn until tight.
2. Press cam into pre-drilled hole until flush with surface.
3. Insert bolt through pre-drilled hole in edge of panel.
4. To lock, rotate cam until tight, using allen key provided.

## Cabinet Assembly

Place Left Side Panel, Right Side Panel, Back Brace, Back Panel and Front Brace on a flat surface. Press the 12 Cams into holes provided (as shown in FIG. B). Point arrow on Cam towards hole Connecting Bolt will enter. Insert (1) Wood Dowel into pre-drilled holes on each end of Back Brace, Front Brace and Filler Strip (as shown in FIG. C).

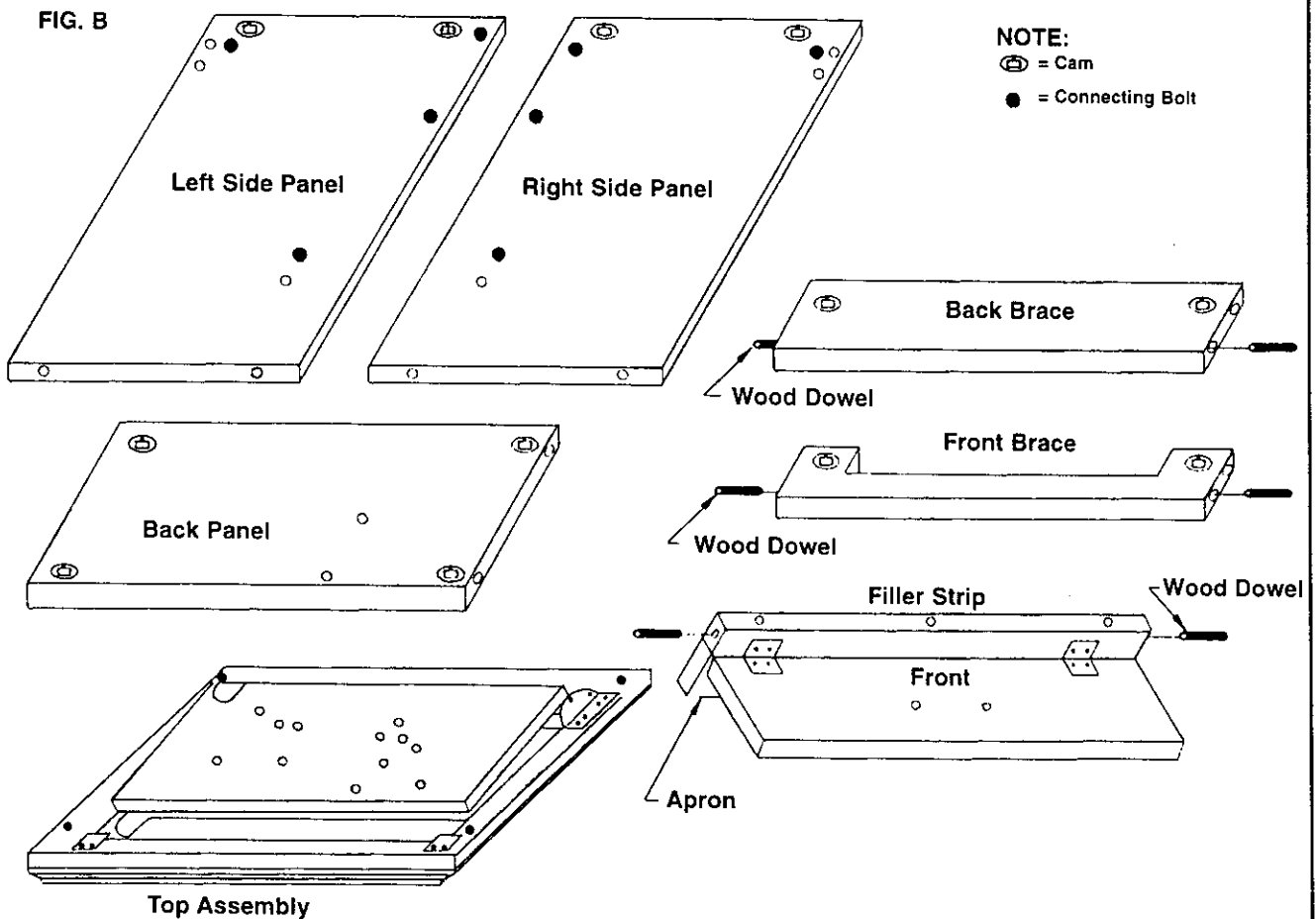

# Assembly Instructions

**STEP 1.** Place Top and Sides on flat surface to thread the (12) Connecting Bolts into the pre-drilled holes (as shown in FIGS. 1 and 2).

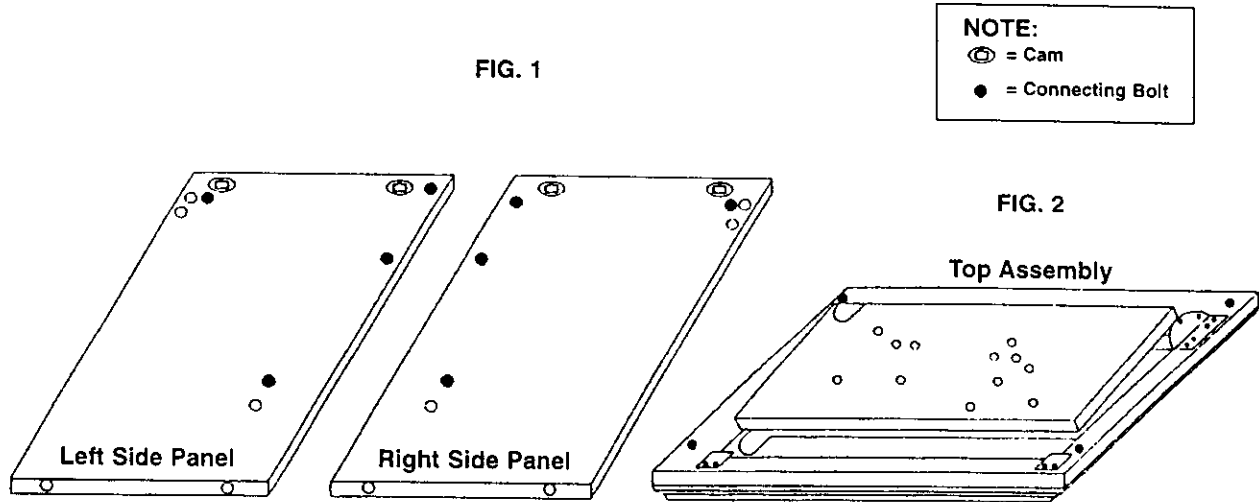

**STEP 2.** Attach Front Brace to Filler Strip (on back side of Front) using (3) 1-1/2" Screws, be sure to position Brace as shown, cut-out down. Attach the Handle with (2) 4.7mm Bolts to the Front. Attach the Rubber Bumpers to the Front Brace using (2) #6x5/8" Panhead Screws, (as shown in FIG. 3). Attach the Front Support to the back side of the Front using (2) #5x1/2" Flathead Screws (as shown in FIG. 3A). Attach the Plastic Tray to the inside of Front (as shown in FIG. 3) with (4) #8x1/2" Panhead Screws.

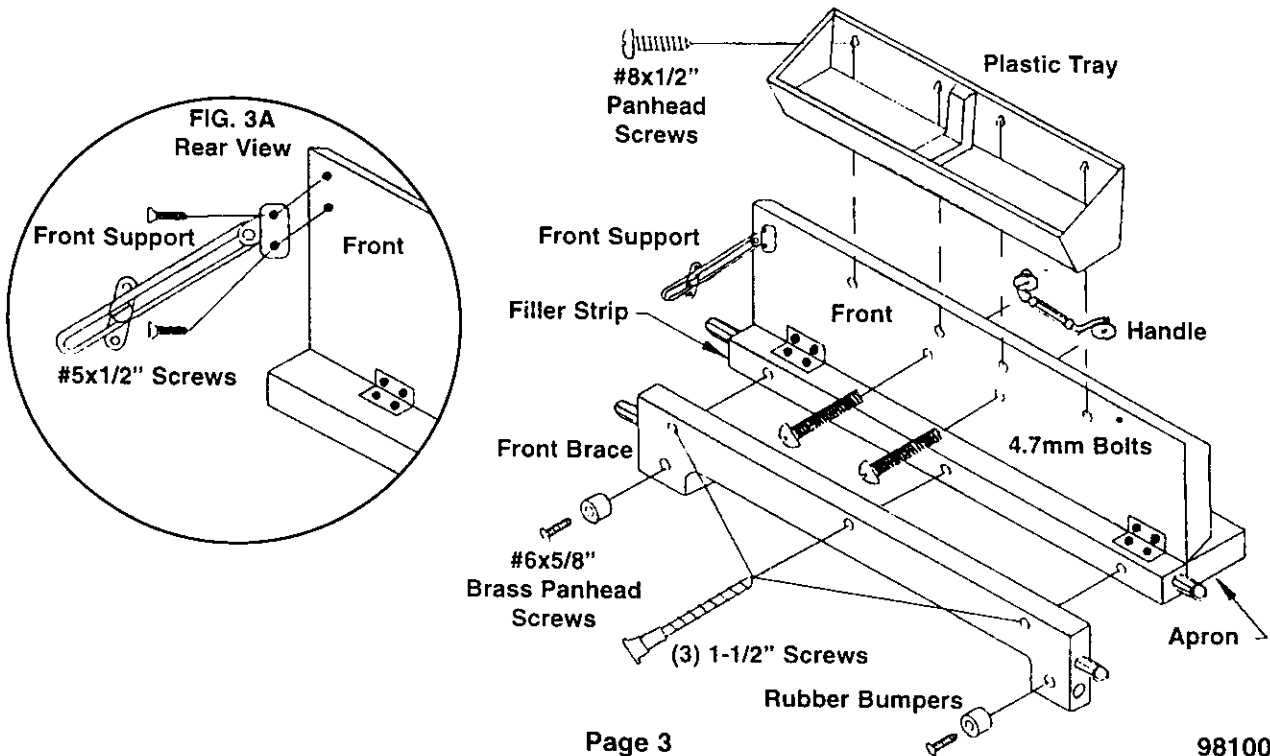

**STEP 3. Attach the Platform Stopper to the Back using (2) #8x1/2" Panhead Screws (as shown in FIG. 4).**

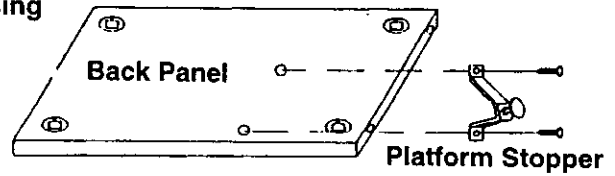

**FOLLOWING ASSEMBLY DONE WITH CABINET UPSIDE DOWN:**

**STEP 4. Attach the Back Panel, Front assembly and Back Brace onto the Connecting Bolts in the Right Side Panel (as shown in FIG. 5 below). (Attach the Back Panel first, to help support unit when assembling). Turn Cams into locked position. Next attach Left Side Panel (upside down) by guiding the Connecting Bolts into the parts attached to the Right Side Panel (as shown in FIG. 6); then Lock Cams. Place Clips and Inserts, in that order, in Side Panel. Tap in Casters (as shown in FIG. 6A), "Locking type in front, "Non-Locking" in the rear.**

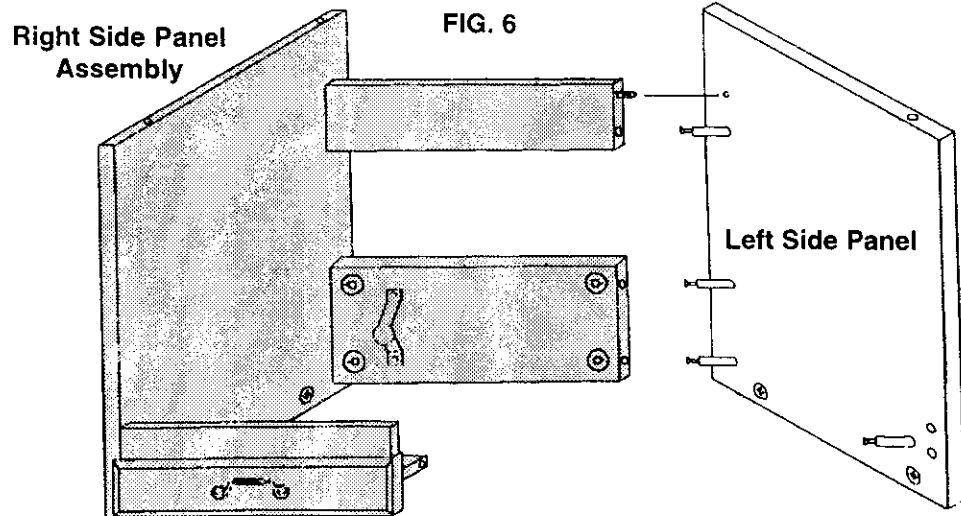
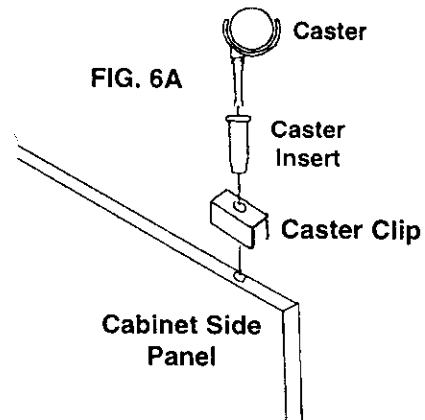
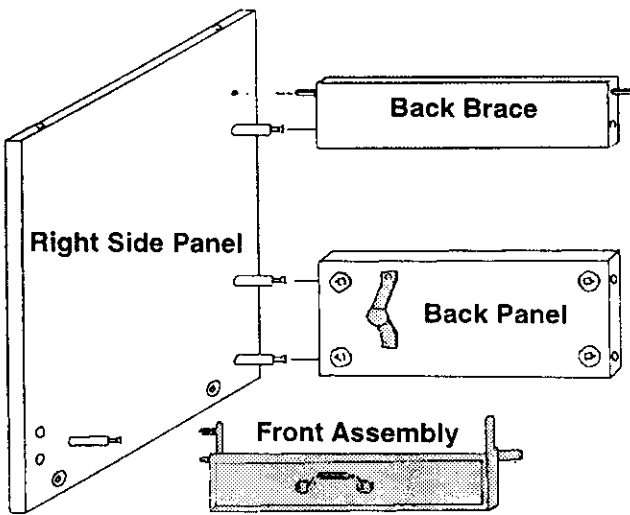

**NOTE: The following assemblies should be done with the Cabinet upright.**

- STEP 5. Attach Hinges to Leaf Supports with (4) #8x5/8" Flathead Screws each, tap in Magnet with hammer, (as shown in FIG. 8B).
- STEP 6. Attach the Leaf Support to Left Side Panel with (4) #8x5/8" Flathead Screws, (as shown in FIG. 7). Attach the Bronze Strike to Side Panel with (1) #5x1/2" Screw.
- STEP 6A. Attach the Front Support to the Left side with (2) #5x1/2" Flathead Screws (as shown in FIG. 8). Tension can be adjusted on the Front Support by tightening the Adjustment Screw (as shown in FIG. 8A). Attach Self Sticking Rubber Tab on top edge of Leaf Support (as shown in FIG. 8B).

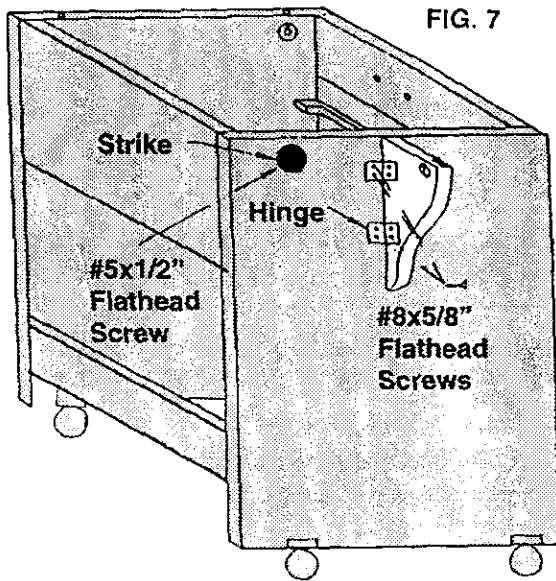

FIG. 7

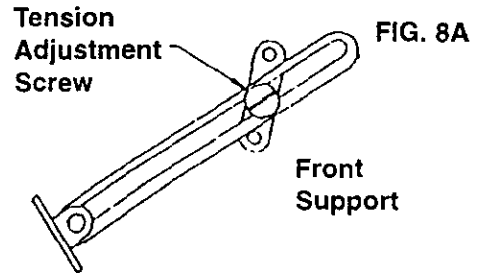

FIG. 8A

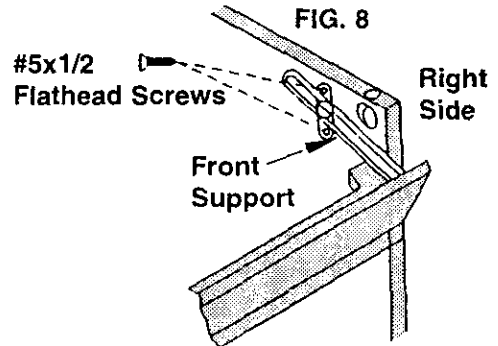

FIG. 8

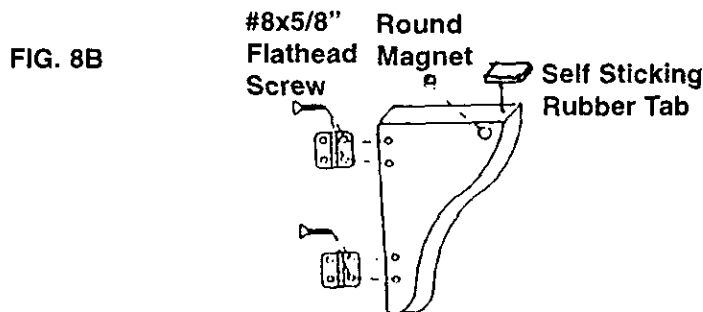
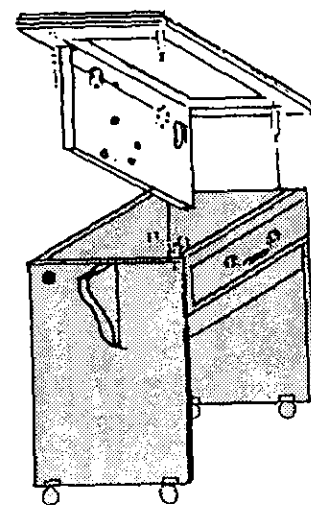

FIG. 8B

FIG. 9



Top / Base Assembly

- STEP 7. Turn Top over (with Platform hanging down and guide the Connecting Bolts into the holes on top edge of Sides. Swing out the Leaf Support and rest the Leaf on the Leaf Support. Reach through the opening in the Top and Turn Cams to the locked position, (as shown in FIG. 9).

# Installing Sewing Machine in your new Cabinet.

It may be helpful to read the directions for operating the mechanism before proceeding with the following steps. See page 7, and FIG. 12, on this page.

- STEP 1. To prevent damage to Cabinet surface, place cushioning material just to the left of cut-out. Lay the sewing machine on its back, on top of cushioning material.
- STEP 2. With Platform in the flatbed position, place Plastic insert into position, making sure the ruler is facing front. This will aid you in positioning the sewing machine.
- STEP 3. Feed machine receptacle cord from the machine control pedal, up through the slot on the right side of the machine platform.
- STEP 4. Insert machine receptacle into terminals provided on the right side of the machine; (this may vary with some machines).
- STEP 5. Thread the two Headmounting Bolts (provided) into the two threaded holes located on the bottom of your machine; twist tight to the collar; (number and type of Bolts may vary with some machines).
- STEP 6. With the plastic insert in place (see page 7) and the front left corner of the machine almost touching the front left corner of the Insert, lower machine onto the Platform, aligning bolts with machine onto the Platform; (some machines may require new holes to be drilled). Next, secure machine to Platform with Washers and Wing Nuts, from underneath Platform. See. FIG. 10 and 11.

While holding machine, lower it into storage position, raise it up to free the arm (to check its operation) then lower it back to the flatbed position. Read operating instructions on page 7 first. Maintenance of Cabinet:

Clean as you do your other fine furniture, using a soft cloth and polish.

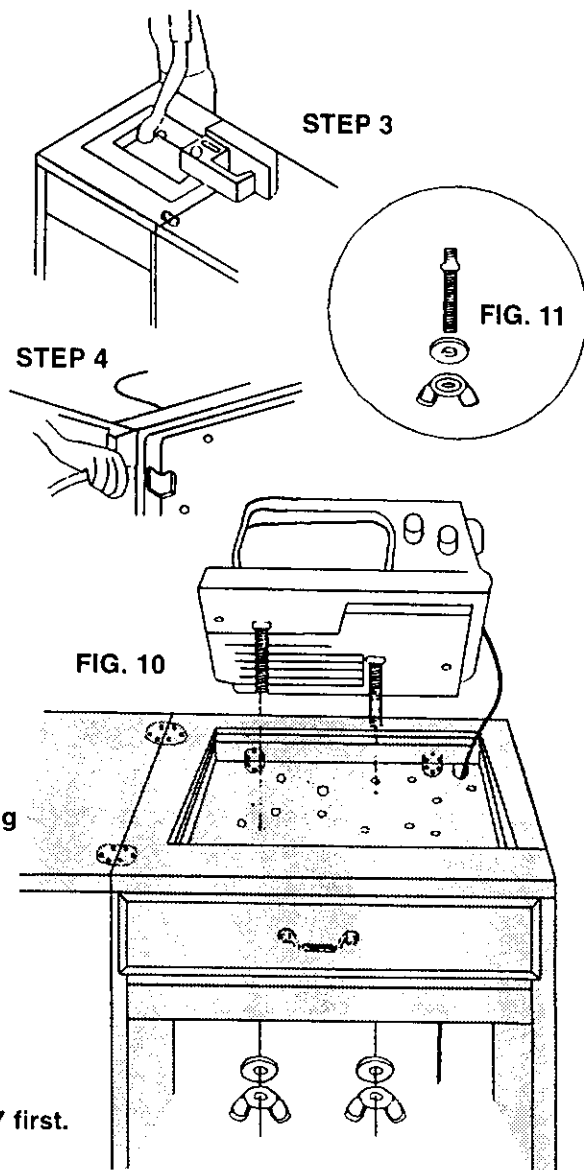

## Understanding How Your Mechanism Works:

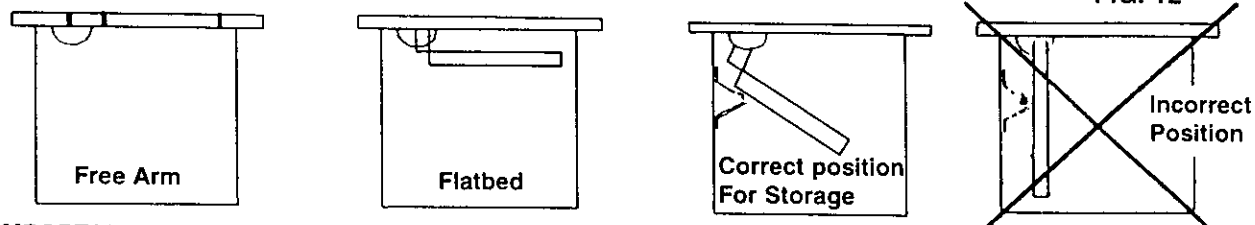

**IMPORTANT:** To move smoothly from one position to another, make sure you do so slowly with both hands, and always make sure you hear the CLICK after each position change. The machine may be lowered for proper clearance from closed leaf while in the storage position by adjusting stopper bolt on back panel.

## Operating the Mechanism in your Cabinet

To move from **FLATBED POSITION TO FREE-ARM position:** (See FIG. 13, 14 and 15.)

- (1.) Remove **INSERT**
- (2.) Lift and tilt machine slightly backwards.
- (3.) Rotate release lever to the right, (clockwise) to unlock.
- (4.) Lift and bring machine forward until it locks into the new position. Listen for **CLICK**. Let platform rest on tabs.

FIG. 13

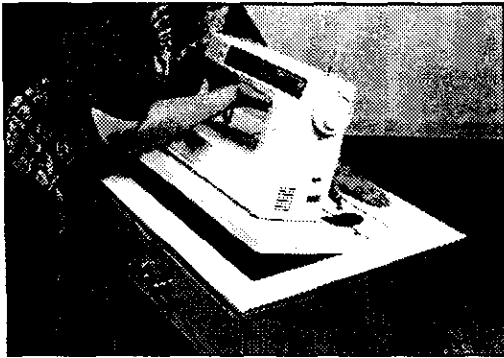
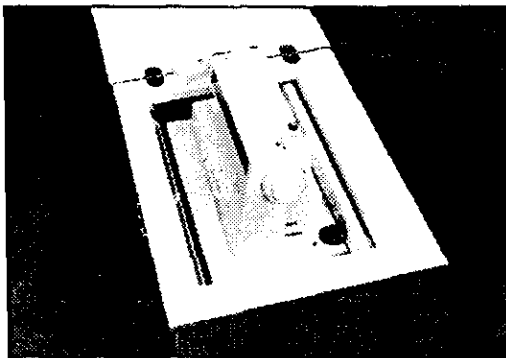

FIG. 14



To move your machine from **FREE-ARM position to FLATBED position:** (See FIGS. 13, 14 and 15).

- (1.) Lift and tilt machine slightly forward.
- (2.) Rotate release lever to the right, (clockwise) to unlock.
- (3.) Allow the machine to lower into cabinet. When you hear the **CLICK** you will know it is in the **FLATBED** position. Let platform rest on front brace.
- (4.) Replace **INSERT**.

FIG. 15

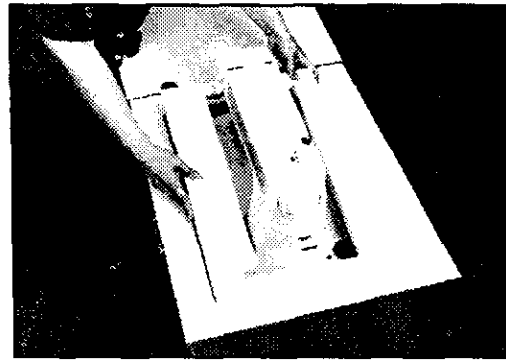

FIG. 16

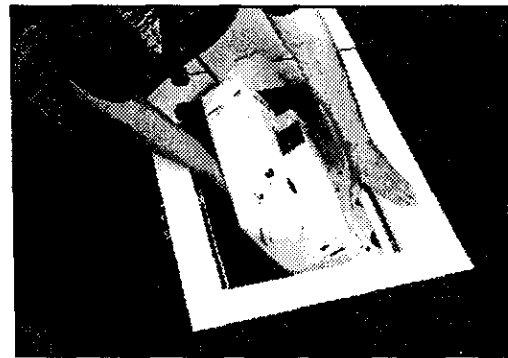
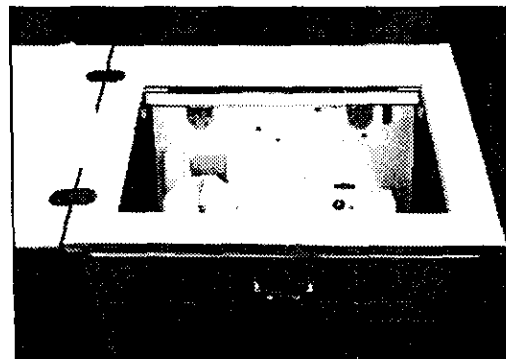

FIG. 17



To move machine from **FLATBED position to STORAGE position:** (See FIGS. 15, 16 and 17).

- (1.) Remove **INSERT**.
- (2.) Once again, lift and tilt machine backwards.
- (3.) Rotate release lever to the right, (clockwise) to unlock
- (4.) Lower and push machine backwards and up until it locks into position. **MAKE SURE YOU HEAR THE CLICK**. See FIGS. 16 and 17.
- (5.) Replace **INSERT** in top opening. Should the Insert not sit flush to the cabinet top, adjust the **Stop Bolt** on the back of the cabinet to lower the machine sufficiently.



# Wood Parts List

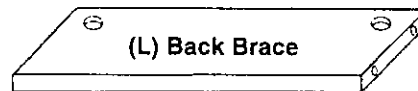
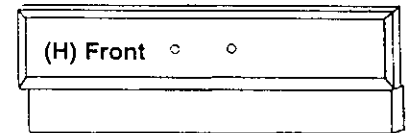
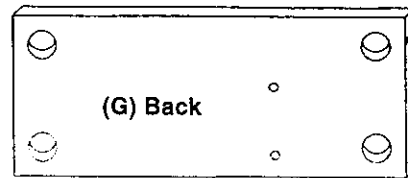
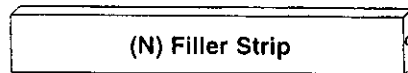
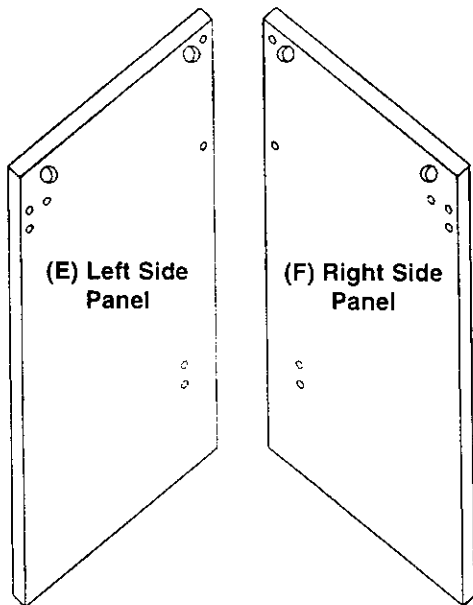
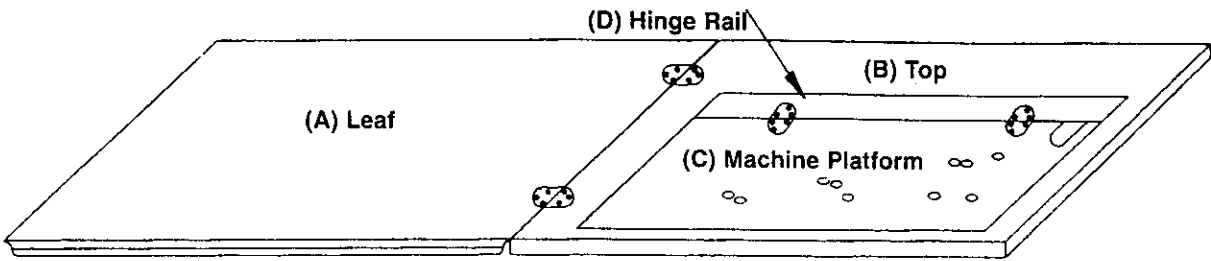

(J) Insert (Plastic)

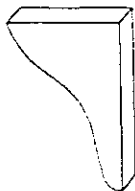

(M) Leaf Support Panel

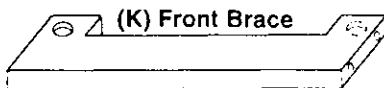

(K) Front Brace

| REF. | DESCRIPTION        | PART # |
|------|--------------------|--------|
| A    | Leaf               | 003259 |
| B    | Top                | 003263 |
| C    | Machine Platform   | 003265 |
| D    | Hinge Rail         | 003266 |
| E    | Left Side Panel    | 003260 |
| F    | Right Side Panel   | 003261 |
| G    | Back               | 003262 |
| H    | Front              | 003264 |
| I    | Apron              | 003267 |
| J    | Insert (Plastic)   | 003159 |
| K    | Front Brace        | 003270 |
| L    | Back Brace         | 003269 |
| M    | Leaf Support Panel | 003271 |
| N    | Filler Strip       | 003268 |

# Hardware Parts List

(A) 19mm Cam (B) Connecting Bolt (C) Rubber Bumpers

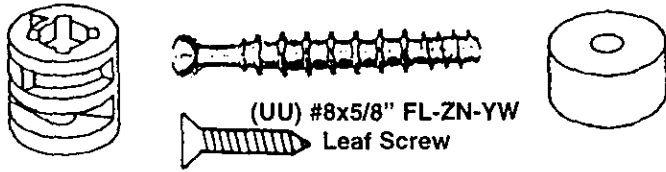

(D) Mounting Bolt (E) Washer (F) Wing Nut



(H) Support Panel Hinge (J) Plastic Tray

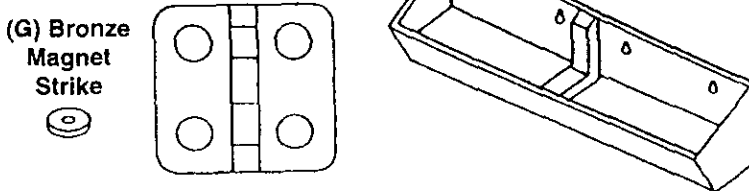

(K) Handle Bolt (L) #8x1/2" Screw (M) #5x1/2" Screw

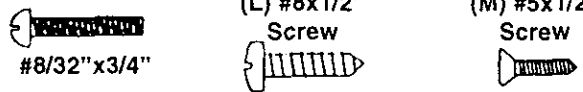

(N) 1-1/2" Flathead Screw (P) Allen Key

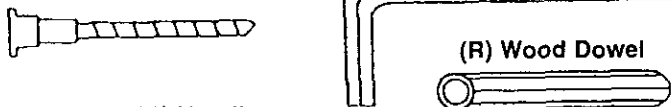

(Q) Handle

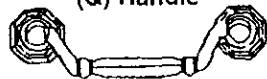

(T) Caster Insert (W) Front Support (S) Caster Clip

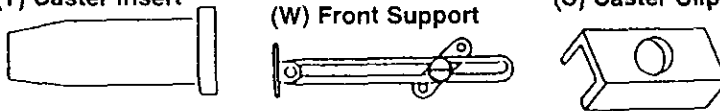

(U) Caster(Locking)

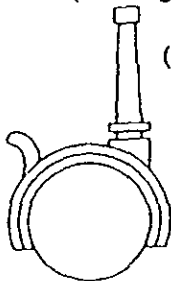

(V) Caster (Non-Locking)

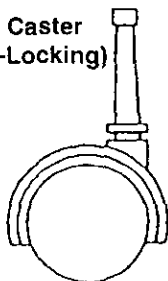

(Z) Platform Hinge

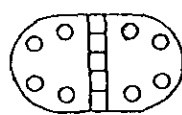

(AA) Leaf Hinge

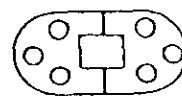

(BB) Front Hinge



(X) #8x5/8" Brz. Screw

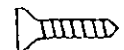

(FF) Self Sticking Rubber Tab



(CC) Round Magnet (DD) Platform Tab

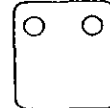

(TT) Manual

| REF. | DESCRIPTION                    | PART#   |
|------|--------------------------------|---------|
| A    | 19mm Cam                       | 000709  |
| B    | Connecting Bolt                | 002892  |
| C    | Rubber Bumper                  | 002466  |
| D    | Mounting Bolt                  | 002890  |
| E    | 1/4" Washer                    | 000220  |
| F    | 1/4" - 20 Wing Nut             | 000488  |
| G    | Bronze Magnet Strike           | 000839  |
| H    | Support Panel Hinge            | 002734  |
| J    | Plastic Tray                   | 003146  |
| K    | Handle Bolt                    | 003191  |
| L    | #8x1/2" Screw                  | 002614  |
| M    | #5x1/2" Screw                  | 000916  |
| N    | 1-1/2" Flathead Screw          | 001222  |
| P    | Allen Key                      | 000712  |
| Q    | Handle                         | 003169  |
| R    | Wood Dowel                     | 002549  |
| S    | Caster Clip                    | 000324  |
| T    | Caster Insert                  | 000368  |
| U    | Caster (Locking)               | 001135  |
| V    | Caster (Non-Locking)           | 001136  |
| W    | Front Support                  | 002547  |
| X    | #8x5/8" Brz. Screw             | 002570  |
| Y    | Spring Hinge                   | 000264  |
| Z    | Platform Hinge                 | 002553  |
| AA   | Leaf Hinge                     | 002733  |
| BB   | Front Hinge                    | 002551  |
| CC   | Round Magnet                   | 002854  |
| DD   | Platform Tab                   | 000086  |
| EE   | #6x5/8" Brass Panhead          | 000083  |
| FF   | Self Sticking Rubber Tab       | 003174  |
| TT   | Manual                         | 003147A |
| UU   | 8x5/8" FH-ZN/Yellow Leaf Screw | 003173  |

(EE) #6x5/8" Brass Panhead



# 3-Position Mechanism Parts

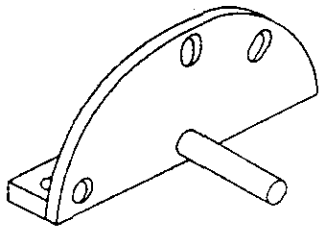

(EE) Right Bracket

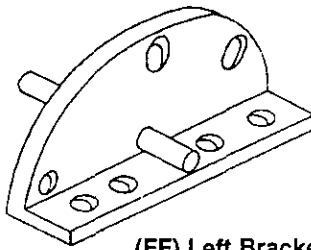

(FF) Left Bracket

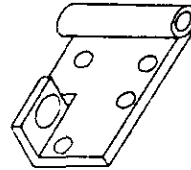

(GG) Right Hinge

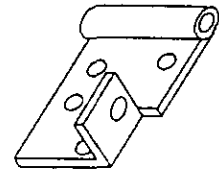

(HH) Left Hinge

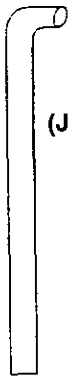

(JJ) Small Rod

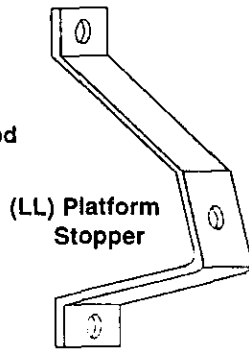

(LL) Platform Stopper



(MM) 1/4" 20 Hex Nut

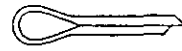

(OO) Cotter Pin



(RR) Spring

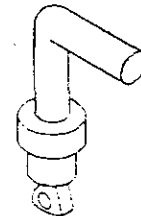

(PP) Release Lever



(SS) Plastic Spacer

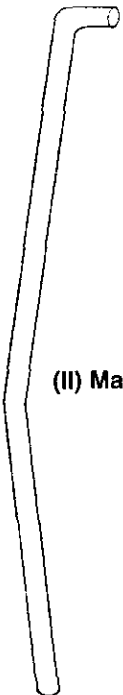

(II) Main Rod



(QQ) Lever Cap



(NN) Adjustment Screw

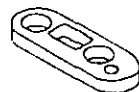

(KK) Pivot

| Item | Description      | Part Number |
|------|------------------|-------------|
| EE   | Right Bracket    | 000151      |
| FF   | Left Bracket     | 000150      |
| GG   | Right Hinge      | 000153      |
| HH   | Left Hinge       | 000152      |
| II   | Main Rod         | 000154      |
| JJ   | Small Rod        | 000155      |
| KK   | Pivot            | 000156      |
| LL   | Platform Stopper | 000157      |
| MM   | 1/4" 20 Hex Nut  | 000158      |
| NN   | Adjustment Screw | 000159      |
| OO   | Cotter Pin       | 000163      |
| PP   | Release Lever    | 000164      |
| QQ   | Lever Cap        | 000165      |
| RR   | Spring           | 000166      |
| SS   | Plastic Spacer   | 000167      |

**API Specialty Furniture**

(A Division of ARROW PRODUCTS, Inc.)

P.O. Box 410, Elkhorn, WI 53121

**1-800-533-7347**

09-99

98100-BC