

® PRO·FORM 590QS

Model No. 831.299240

Serial No. _____

Find the serial number in the location shown below. Write the serial number in the space above for reference.

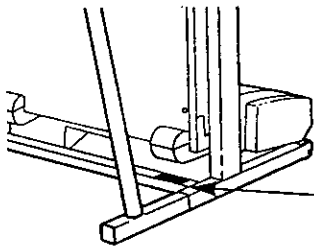

Serial
Number
Decal

USER'S MANUAL

EXERCISE
EQUIPMENT

QUESTIONS

HELPLINE!

1-800-736-6879

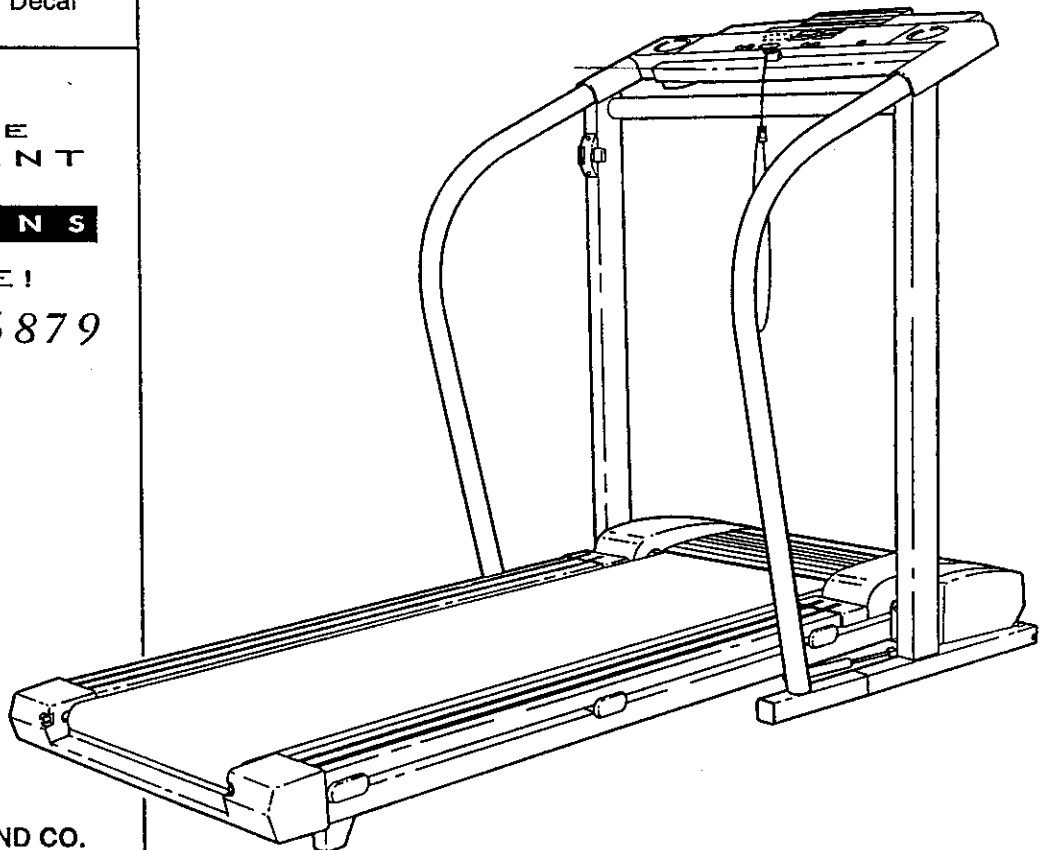

SEARS, ROEBUCK AND CO.
HOFFMAN ESTATES, IL 60179

▲ CAUTION

Read all precautions and instructions in this manual before using this equipment. Save this manual for future reference.

PRO-FORM 590QS

TABLE OF CONTENTS

IMPORTANT PRECAUTIONS	3
BEFORE YOU BEGIN	5
ASSEMBLY	6
OPERATION AND ADJUSTMENT	8
HOW TO FOLD AND MOVE THE TREADMILL	15
MAINTENANCE AND TROUBLE-SHOOTING	16
CONDITIONING GUIDELINES	18
PART LIST	19
ORDERING REPLACEMENT PARTS	Back Cover
FULL 90-DAY WARRANTY	Back Cover

Note: An EXPLODED DRAWING is attached in the center of this manual.

IMPORTANT PRECAUTIONS

⚠ WARNING: To reduce the risk of burns, fire, electric shock, or injury to persons, read the following important precautions and information before operating the treadmill.

1. It is the responsibility of the owner to ensure that all users of this treadmill are adequately informed of all warnings and precautions.
2. Use the treadmill only as described in this manual.
3. Place the treadmill on a level surface, with at least eight feet of clearance behind it. Do not place the treadmill on any surface that blocks air openings. To protect the floor or carpet from damage, place a mat under the treadmill.
4. Keep the treadmill indoors, away from moisture and dust. Do not put the treadmill in a garage or covered patio, or near water.
5. Do not operate the treadmill where aerosol products are used or where oxygen is being administered.
6. Keep children under the age of 12 and pets away from the treadmill at all times.
7. The treadmill should not be used by persons weighing more than 250 pounds.
8. Never allow more than one person on the treadmill at a time.
9. Wear appropriate exercise clothing when using the treadmill. Do not wear loose clothing that could become caught in the treadmill. Athletic support clothes are recommended for both men and women. *Always wear athletic shoes. Never use the treadmill with bare feet, wearing only stockings, or in sandals.*
10. When connecting the power cord (see page 8), plug the power cord into a surge suppressor (not included) and plug the surge suppressor into a grounded circuit capable of carrying 15 or more amps. No other appliance should be on the same circuit. Do not use an extension cord.
11. Use only a single-outlet surge suppressor that is UL 1449 listed as a transient voltage surge suppressor (TVSS). The surge suppressor must have a UL suppressed voltage rating of 400 volts or less and a minimum surge dissipation of 450 joules. The surge suppressor must be electrically rated for 120 volts AC and 15 amps.
12. Keep the power cord and the surge suppressor away from heated surfaces.
13. Never move the walking belt while the power is turned off. Do not operate the treadmill if the power cord or plug is damaged, or if the treadmill is not working properly. (See **BEFORE YOU BEGIN** on page 5 if the treadmill is not working properly.)
14. Never start the treadmill while you are standing on the walking belt. Always hold the handrails while using the treadmill.
15. The treadmill is capable of high speeds. Adjust the speed in small increments to avoid sudden jumps in speed.
16. The pulse sensor is not a medical device. Various factors, including the user's movement, may affect the accuracy of heart rate readings. The pulse sensor is intended only as an exercise aid in determining heart rate trends in general.
17. Never leave the treadmill unattended while it is running. Always remove the key, unplug the power cord and move the on/off switch to the off position when the treadmill is not in use. (See the drawing on page 5 for the location of the on/off switch.)
18. Do not attempt to raise, lower, or move the treadmill until it is properly assembled. (See **ASSEMBLY** on page 6, and **HOW TO FOLD AND MOVE THE TREADMILL** on page 15.) You must be able to safely lift 45 pounds (20 kg) in order to raise, lower, or move the treadmill.
19. Do not change the incline of the treadmill by placing objects under the treadmill.
20. When folding or moving the treadmill, make sure that the storage latch is fully closed.

21. When using i-Fit.com CD's and videos, an electronic "chirping" sound will alert you when the speed and/or incline of the treadmill is about to change. Always listen for the "chirp" and be prepared for speed and/or incline changes. In some instances, the speed and/or incline may change before the personal trainer describes the change.

22. When using i-Fit.com CD's and videos, you can manually override the speed and incline settings at any time by pressing the speed and incline buttons. However, when the next "chirp" is heard, the speed and/or incline will change to the next settings of the CD or video program.

23. Always remove i-Fit.com CD's and videos from your CD player or VCR when you are not using them.

24. Inspect and tighten all parts of the treadmill regularly.

25. Never insert or drop any object into any opening.

26. **DANGER:** Always unplug the power cord immediately after use, before cleaning the treadmill, and before performing the maintenance and adjustment procedures described in this manual. Never remove the motor hood unless instructed to do so by an authorized service representative. Servicing other than the procedures in this manual should be performed by an authorized service representative only.

27. This treadmill is intended for in-home use only. Do not use this treadmill in any commercial, rental, or institutional setting.

WARNING: Before beginning this or any exercise program, consult your physician. This is especially important for persons over the age of 35 or persons with pre-existing health problems. Read all instructions before using. SEARS assumes no responsibility for personal injury or property damage sustained by or through the use of this product.

SAVE THESE INSTRUCTIONS

The decals shown below have been placed on your treadmill. If a decal is missing, or if it is not legible, please call our toll-free HELPLINE to order a free replacement decal (see the back cover of this manual). Apply the decal in the location shown.

WARNING: Protect yourself and others from risk of serious injury. Read the user's manual and:

- Fully engage storage latch before treadmill is moved or stored.
- Reduce incline to lowest level before folding treadmill into storage position.
- Stand only on side rails when starting or stopping treadmill.
- Change speed in small increments.
- Hold handrails to prevent falling, and always wear the safety clip while operating treadmill.
- Stop if you feel faint, dizzy, or short of breath.
- Never allow children on or around treadmill.
- Remove key when not in use.
- Keep clothing, fingers, and hair away from moving belt.
- Never try to adjust or fix the belt while it is moving.
- Always wear athletic shoes while operating treadmill.





Note: This decal is shown at 38% of actual size.

CAUTION
 KEEP HANDS AND FEET AWAY FROM THIS AREA WHILE THE TREADMILL IS IN OPERATION.

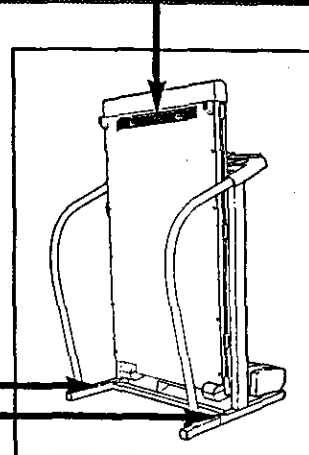

BEFORE YOU BEGIN

Thank you for selecting the revolutionary PROFORM® 590QS treadmill. The 590QS treadmill combines advanced technology with innovative design to help you get the most from your exercise program in the convenience and privacy of your home. And when you're not exercising, the unique 590QS can be folded up, requiring less than half the floor space of other treadmills.

For your benefit, read this manual carefully before using the treadmill. If you have additional questions, please call our toll-free HELPLINE at 1-800-736-6879,

Monday through Saturday, 7 a.m. until 7 p.m. Central Time (excluding holidays). To help us assist you, please note the product model number and serial number before calling. The model number of the treadmill is 831.299240. The serial number can be found on a decal attached to the treadmill (see the front cover of this manual for the location).

Before reading further, please review the drawing below and familiarize yourself with the parts that are labeled.

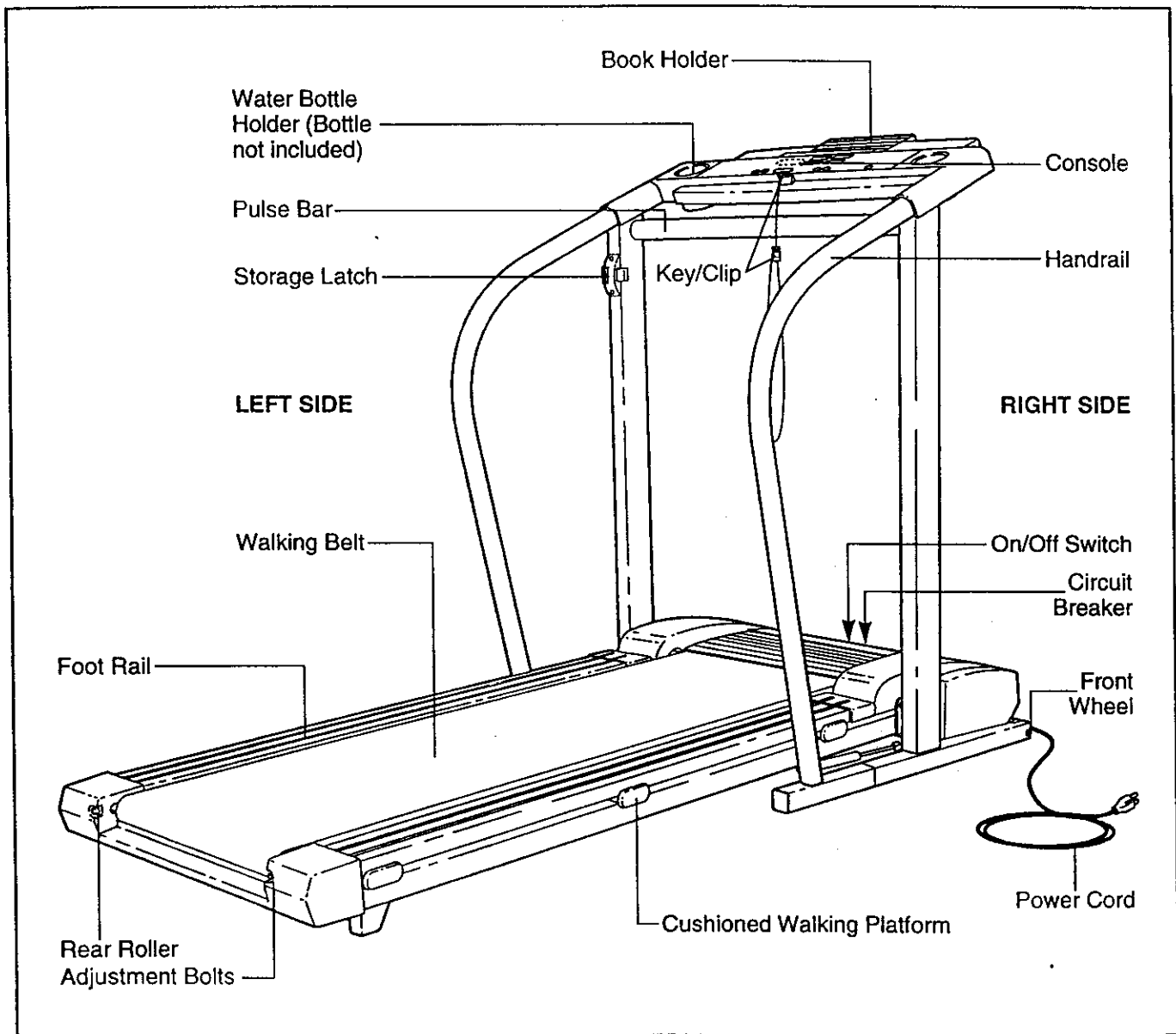

ASSEMBLY

Assembly requires two people. Set the treadmill in a cleared area and remove all packing materials. Do not dispose of the packing materials until assembly is completed. **Assembly requires the included allen wrench and your own phillips screwdriver** .

Note: The underside of the treadmill walking belt is coated with high-performance lubricant. During shipping, a small amount of lubricant may be transferred to the top of the walking belt or the shipping carton. This is a normal condition and does not affect treadmill performance. If there is lubricant on top of the walking belt, simply wipe off the lubricant with a soft cloth and a mild, non-abrasive cleaner.

1. With the help of a second person, carefully raise the treadmill to the upright position.

While a second person tips the treadmill to one side and holds it, insert one of the Extension Legs (103) into the treadmill as shown. Make sure that the Extension Leg is turned so the Base Pad (97) is on the bottom.

Next, tip the treadmill to the other side and insert the other Extension Leg (not shown) in the same way. Lower the side of the treadmill so that both Extension Legs (103) are resting flat on the floor.

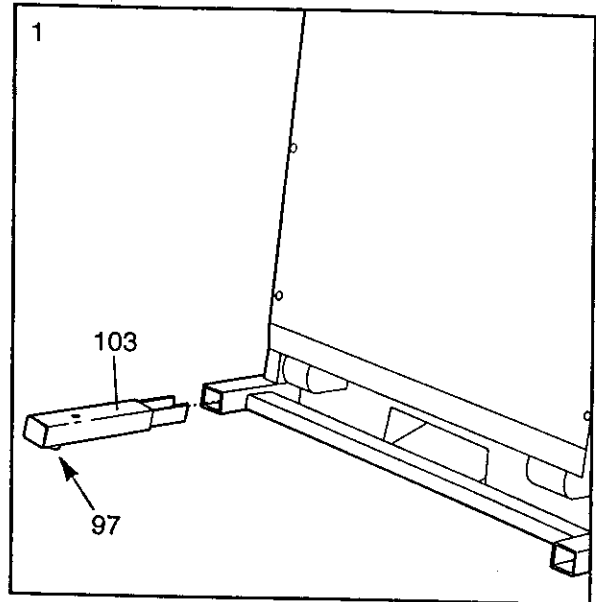

2. Refer to HOW TO LOWER THE TREADMILL FOR USE on page 15. Follow the instructions in step 2 to lower the treadmill.

Hold the latch spacer and the latch support together as shown. Attach the latch spacer and the latch support to the center hole in the left Upright (82) with a 3/4" Screw (89). **Make sure that the Screw is tight, but do not over-tighten it; if the Screw is overtightened, the latch will not slide smoothly.**

Remove the tape from the Latch Assembly (77). **Be careful to hold the parts together.** Inset drawing A shows how the Latch Assembly fits together. Inset drawing B shows how the springs fit into the bracket. Make sure that the tabs on the latch are touching the bracket and that the back end of the latch is flush with the bracket.

Attach the Latch Assembly (77) to the left Upright (82) with two 3/4" Screws (89).

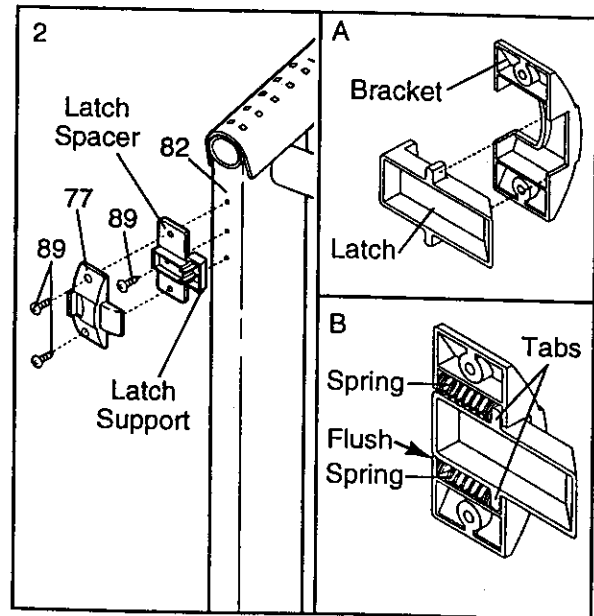

- Slide the upper end of a Handrail (85) into the right Upright (82) as shown. **Note: It will be necessary to pivot the Handrail to the side and back repeatedly (see arrow A) while pushing on the Handrail (see arrow B) to slide it fully into the Upright.** Next, pivot the lower end of the Handrail down, push it toward the right Upright, and then align it with the indicated hole.

Slide the other Handrail (85) into the left Upright (82) as described above.

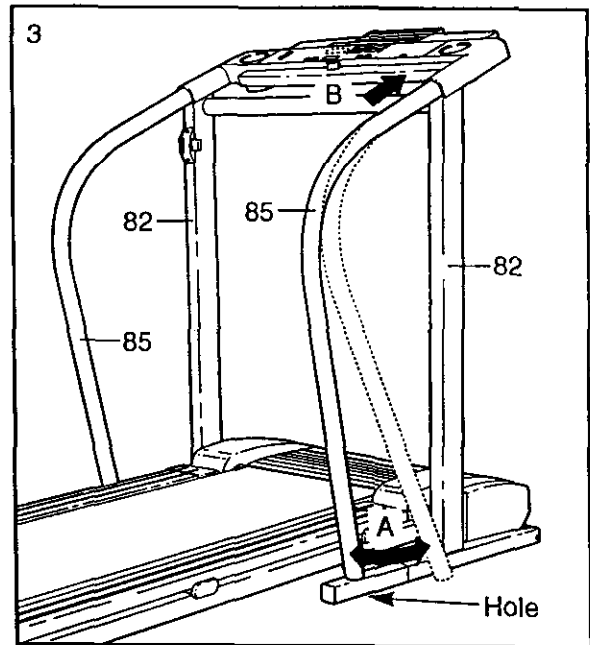

- With the help of a second person, carefully tip the Uprights (82) down as shown. **Make sure that the Extension Legs (103) remain in the Uprights.**

Attach each Extension Leg (103) with two Short Screws (101) as shown.

Next, tighten a Handrail Bolt (78) with a Handrail Washer (96) into each Extension Leg (103) and Handrail (85) as shown. **Note: It may be necessary to move the Handrails up or down to align the Handrails with the holes in the Extension Legs.**

With the help of a second person, carefully tip the Uprights (82) back to the upright position.

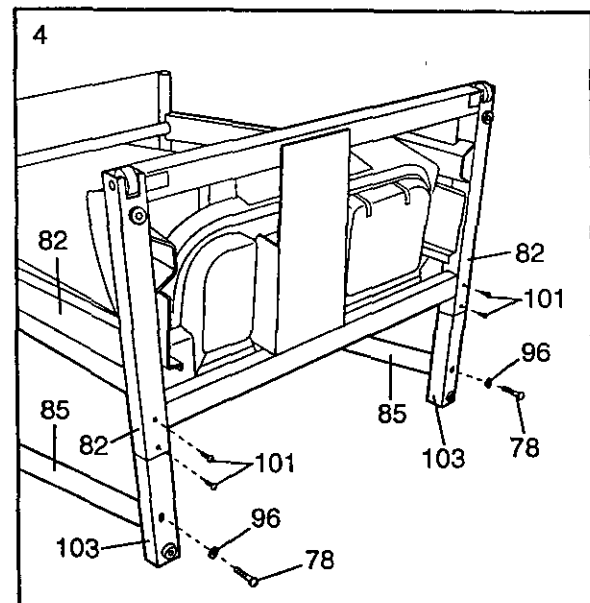

- Make sure that all parts are tightened before you use the treadmill.** Keep the included allen wrench in a secure place. The allen wrench is used to adjust the walking belt (see page 17). To protect the floor or carpet from damage, place a mat under the treadmill.

OPERATION AND ADJUSTMENT

THE PERFORMANT LUBE™ WALKING BELT

Your treadmill features a walking belt coated with PERFORMANT LUBE™, a high-performance lubricant. **IMPORTANT:** Never apply silicone spray or other substances to the walking belt or the walking platform. Such substances will deteriorate the walking belt and cause excessive wear.

HOW TO PLUG IN THE POWER CORD

⚠ DANGER: Improper connection of the equipment-grounding conductor can result in an increased risk of electric shock. Check with a qualified electrician or serviceman if you are in doubt as to whether the product is properly grounded. Do not modify the plug provided with the product—if it will not fit the outlet, have a proper outlet installed by a qualified electrician.

Your treadmill, like any other type of sophisticated electronic equipment, can be seriously damaged by sudden voltage changes in your home's power. Voltage surges, spikes, and noise interference can result from weather conditions or from other appliances being turned on or off. **To decrease the possibility of your treadmill being damaged, always use a surge suppressor with your treadmill (see drawing 1 at the right).**

Surge suppressors are sold at most hardware stores and department stores. Use only a single-outlet surge suppressor that is UL 1449 listed as a transient voltage surge suppressor (TVSS). The surge suppressor must have a UL suppressed voltage rating of 400 volts or less and a minimum surge dissipation of 450 joules. The surge suppressor must be electrically rated for 120 volts AC and 15 amps.

This product must be grounded. If it should malfunction or break down, grounding provides a path of least resistance for electric current to reduce the risk of electric shock. This product is equipped with a cord having an equipment-grounding conductor and a grounding plug. Plug the power cord into a surge suppressor, and plug the surge suppressor into an appropriate outlet that is properly installed and grounded in accordance with all local codes and ordinances.

This product is for use on a nominal 120-volt circuit, and has a grounding plug that looks like the plug illustrated in drawing 1 below. A temporary adapter that looks like the adapter illustrated in drawing 2 may be used to connect the surge suppressor to a 2-pole receptacle as shown in drawing 2 if a properly grounded outlet is not available.

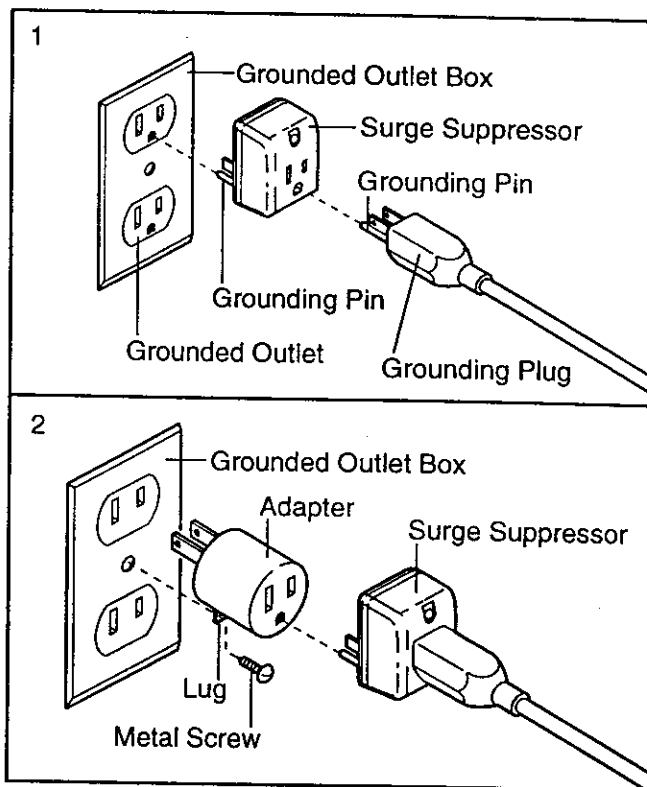

The temporary adapter should be used only until a properly grounded outlet (drawing 1) can be installed by a qualified electrician.

The green-colored rigid ear, lug, or the like extending from the adapter must be connected to a permanent ground such as a properly grounded outlet box cover. Whenever the adapter is used it must be held in place by a metal screw. **Some 2-pole receptacle outlet box covers are not grounded. Contact a qualified electrician to determine if the outlet box cover is grounded before using an adapter.**

CONSOLE DIAGRAM

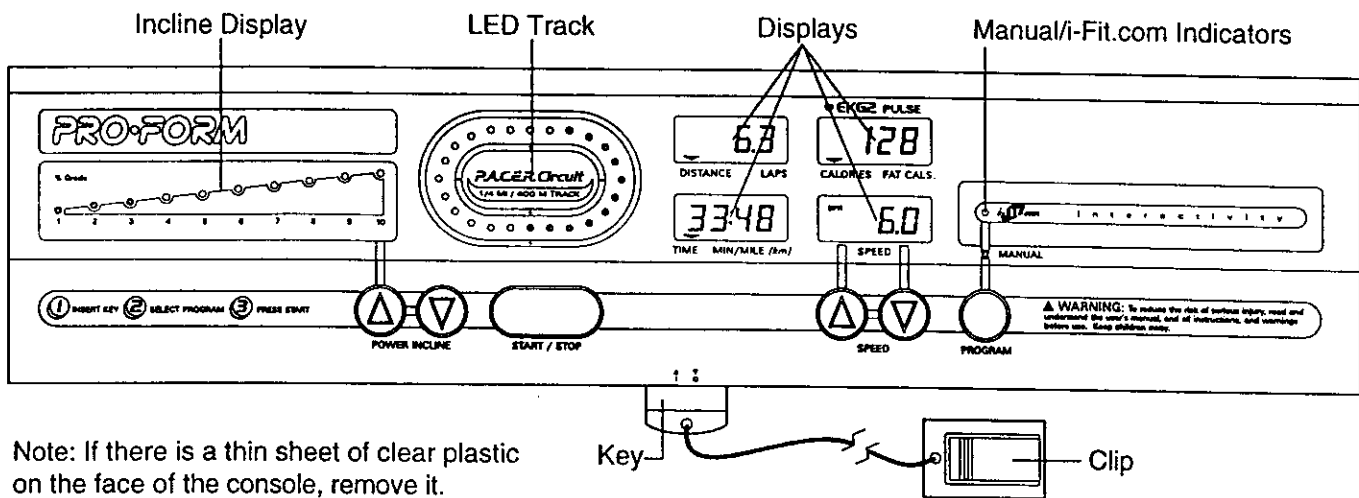

CAUTION: Before operating the console, read the following precautions.

- Do not stand on the walking belt when turning on the power.
- Always wear the clip (see the drawing above) while operating the treadmill.
- Adjust the speed in small increments in order to avoid sudden jumps in speed.
- To reduce the possibility of electric shock, keep the console dry. Avoid spilling liquids on the console and place only a sealed water bottle in the water bottle holder.

FEATURES OF THE CONSOLE

The treadmill console offers an impressive array of features designed to help you get the most from your exercise program. When the manual mode of the console is selected, the speed and incline of the treadmill can be changed with a touch of a button. As you exercise, four displays will provide continuous exercise feedback. You can even measure your heart rate using the built-in pulse sensor.

The console also features revolutionary i-Fit.com interactive technology. This breakthrough technology is like having a personal trainer right in your home. Using the included audio cable, you can connect the treadmill to

your home stereo, portable stereo, or computer, and play special i-Fit.com CD's (not included). These CD's interactively control the speed and incline of the treadmill while a personal trainer coaches you through each step of your workout. High-energy music provides added motivation. Each CD features two different 30-minute workout programs designed by certified personal trainers.

In addition, you can connect the treadmill to your VCR and TV and play i-Fit.com videocassettes (not included). These unique videos offer the same benefits as i-Fit.com CD's, but add the excitement and motivation of working out with a group and an instructor—the hottest new trend at health clubs.

By plugging an optional upgrade module into the console, you can add virtually endless options to your treadmill. The upgrade module enables you to connect the treadmill to your home computer and log on to www.i-fit.com, our powerful internet site to be launched October 1, 1999. By accessing www.i-fit.com, you can download a large selection of workout programs that match your specific exercise goals; access CD and video workouts via the internet; participate in live web-cast workouts; and watch exercise demonstrations via web video conferences. You can even chat live with your personal trainer and get individual fitness instruction.

To purchase i-Fit.com CD's or videocassettes, or to purchase the optional upgrade module, visit your local department store or sporting goods store or go to www.i-fit.com.

STEP-BY-STEP CONSOLE OPERATION

Before operating the console, make sure that the on/off switch near the power cord is in the on position. Next, make sure that the key is removed from the console and the power cord is properly plugged in (see HOW TO PLUG IN THE POWER CORD on page 8).

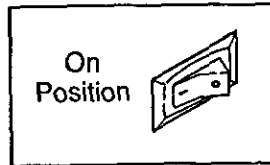

When you are ready to begin exercising, step onto the foot rails of the treadmill. Find the clip attached to the key (see the drawing on page 9), and slide the clip onto the waistband of your clothing.

To use the manual mode, follow the steps below and on page 11. To use i-Fit.com CD's or videocassettes (not included), refer to pages 12 and 13. To use other i-Fit.com technology, see page 13.

Note: The console can display speed and distance in either miles or kilometers (see SPEED DISPLAY on page 11). For simplicity, all instructions in this manual refer to miles.

HOW TO USE THE MANUAL MODE

1 Insert the key fully into the console.

When the key is inserted, the four displays and various indicators on the console will light.

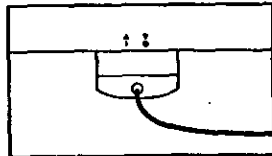

2 Select the manual mode.

When the key is inserted, the manual mode will automatically be selected. If the i-Fit.com indicator is lit, press the PROGRAM button to select the manual mode.

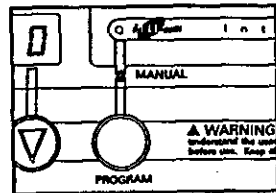

3 Press the START/STOP button or the SPEED Δ button to start the walking belt.

A moment after the button is pressed, the walking belt will begin to move at 1 mph. Hold the handrails and carefully

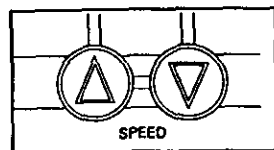

begin walking. As you exercise, change the speed of the walking belt as desired by pressing the SPEED buttons.

To stop the walking belt, press the START/STOP button. The TIME/MIN-MILE display will begin to flash. To restart the walking belt, press the START/STOP button or the SPEED Δ button.

4 Change the incline of the treadmill as desired.

To change the incline of the treadmill, press the incline buttons. Each time a button is pressed, the incline will change by 0.5%. The buttons can be held down to change the incline rapidly.

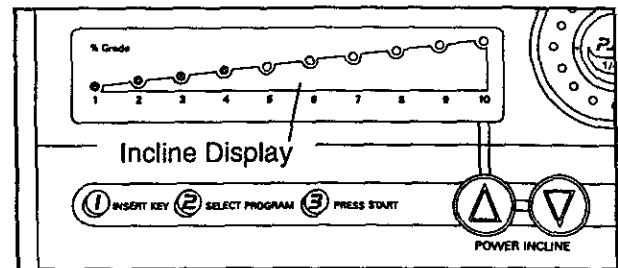

Note: In the incline display, the first indicator will light when the incline is set at 1.5%. The second indicator will light when the incline is set at 2% or 2.5%, the third indicator will light when the incline is set at 3% or 3.5%, and so forth. After the incline buttons are pressed, it will take a moment for the treadmill to reach the selected incline setting.

5 Follow your progress with the LED track and the four displays.

The LED Track—

The LED track represents a distance of 1/4 mile. As you exercise, the indicators around the track will light one at a time until you have completed 1/4 mile. A new lap will then begin.

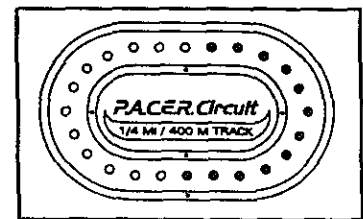

DISTANCE/LAPS display—This display shows the distance that you have walked or run and the number of laps you have completed (one lap equals 1/4 mile). The display will alternate between one number and the other every seven seconds, as shown by the arrows in the display.

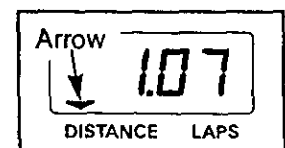

TIME/MIN-MILE

display—This display shows the elapsed time and your current pace (pace is measured in *minutes per mile*). Your pace will be shown for three seconds each time the speed is adjusted.

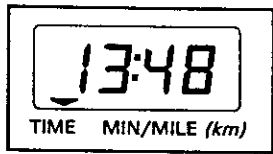

CALS./FAT CALS./

PULSE display—This display shows the approximate numbers of *calories* and *fat calories* you have burned (see **FAT BURNING** on page 18). Every seven seconds, the display will change from one number to the other, as shown by the arrows in the display. This display will also show your heart rate when the pulse sensor is used (see step 6 on this page).

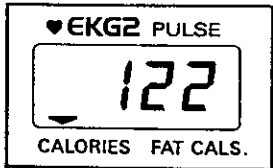

SPEED display—This display shows the speed of the walking belt, in miles per hour or kilometers per hour. The letters “MPH” or “KPH” will show which unit of measurement is selected.

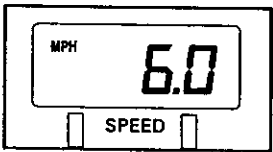

To change the unit of measurement, hold down the **START/STOP** button while inserting the key into the console. An “E,” for english miles, or an “M,” for metric kilometers, will appear in the **SPEED** display. Press the **SPEED Δ** button to change the unit of measurement. When the desired unit of measurement is selected, remove and then reinsert the key.

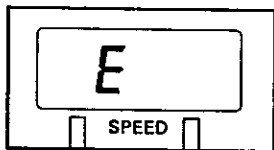

6 Measure your pulse, if desired.

Stand on the foot rails and place your hands on the metal contacts on the pulse bar. Your palms must be resting on the upper contacts, and your fingers must be touching the lower contacts—**avoid moving your hands.**

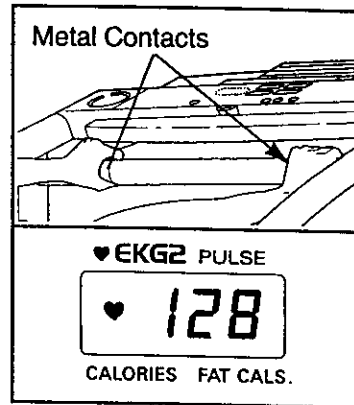

When your pulse is detected, the heart-shaped indicator in the **CALS./FAT CALS./PULSE** display will flash **steadily** and a series of dashes (— —) will appear. After a few seconds, your heart rate will be shown. **For the most accurate heart rate reading, continue to hold the contacts for about 15 seconds.**

7 When you are finished exercising, remove the key.

Step onto the foot rails, press the **START/STOP** button, and remove the key from the console. Keep the key in a secure place. **Note: If the displays and various indicators on the console remain lit after the key is removed, the console is in the “demo” mode. Refer to page 14 and turn off the demo mode.**

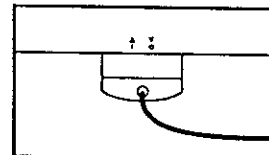

When you are finished using the treadmill, move the on/off switch near the power cord to the off position.

HOW TO USE I-FIT.COM CD'S AND VIDEOS

To purchase i-Fit.com CD's and videos (not included), visit your local department store or sporting goods store or go to www.i-fit.com.

To use i-Fit.com CD's, you must first connect the treadmill to your home stereo, portable stereo, or computer with CD player. To do this, follow steps A to D below.

- A. Plug one end of the included audio cable into the jack near the treadmill power cord.

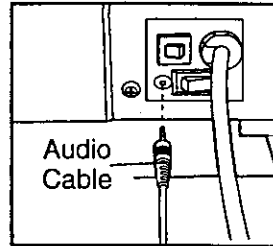

- B. To connect the treadmill to a home stereo, plug the other end of the audio cable into the included adapter and plug the adapter into a LINE OUT or an AUDIO OUT jack on the stereo.

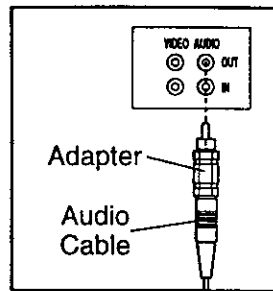

- C. To connect the treadmill to a portable stereo, plug the other end of the audio cable into a LINE OUT or an AUDIO OUT jack on the portable stereo.

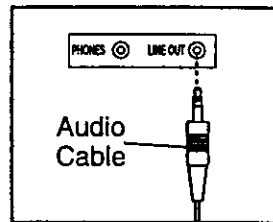

- D. To connect the treadmill to a computer, plug the other end of the audio cable into a LINE OUT or an AUDIO OUT jack on the computer.

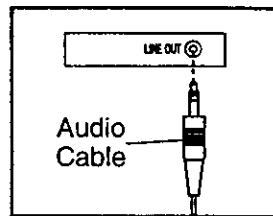

Note: Depending on the model of your stereo or computer, the jacks may be labeled differently. You may need to connect the audio cable to a SPEAKER jack or a HEADPHONE jack. To do this, you must purchase a Y-adapter at your local electronics store. **CAUTION:** You must be able to listen to the audio through speakers or headphones in order to use i-Fit.com CD's or videos.

To use i-Fit.com videos, you must connect the treadmill to your VCR or TV. To do this, follow steps A to C below.

- A. Plug one end of the included audio cable into the jack near the treadmill power cord.

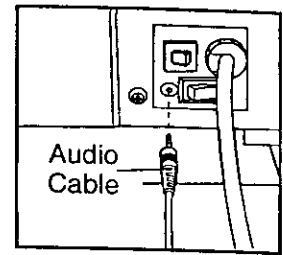

- B. To connect the treadmill to a VCR, plug the other end of the audio cable into the included adapter and plug the adapter into an AUDIO OUT jack on the VCR.

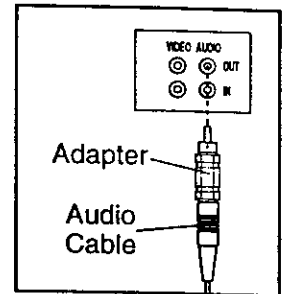

- C. To connect the treadmill to a TV, plug the other end of the audio cable into the included adapter and plug the adapter into an AUDIO OUT jack on the TV.

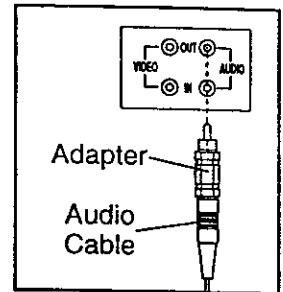

Note: If your VCR is connected to a home stereo, you may connect the audio cable to the home stereo as described in step B at the left. Remember, you must be able to listen to the audio through speakers or headphones in order to use i-Fit.com CD's or videos.

When the audio cable is properly connected, make sure that the on/off switch near the treadmill power cord is in the on position. Next, make sure that the power cord is properly plugged in. Follow the steps below to use an i-Fit.com CD or video.

- 1** Insert the key fully into the console.

When the key is inserted, the four displays and various indicators on the console will light.

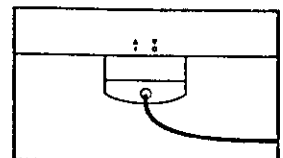

2 Press the PROGRAM button.

When the key is inserted, the manual mode will automatically be selected. To use an i-Fit.com CD or video, press the PROGRAM button. The i-Fit.com indicator will light.

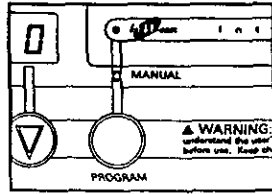

3 Insert the i-Fit.com CD or video.

If you are using an i-Fit.com CD, insert the CD into your CD player. If you are using an i-Fit.com video, insert the video into your VCR.

4 Press the PLAY button on your CD player or VCR.

A moment after the button is pressed, your personal trainer will begin guiding you through your workout. Simply follow your personal trainer's instructions.

During the CD or video program, an electronic "chirping" sound will alert you when the speed and/or incline of the treadmill is about to change. **CAUTION: Always listen for the "chirp" and be prepared for speed and/or incline changes. In some instances, the speed and/or incline may change before the personal trainer describes the change.**

If the speed or incline settings are too high or too low, you can manually override the settings at any time by pressing the SPEED or INCLINE buttons on the console. However, **when the next "chirp" is heard, the speed and/or incline will change to the next settings of the CD or video program.**

To stop the program at any time, press the START/STOP button on the console. The TIME/MIN-MILE display will begin to flash. To restart the program, press the START/STOP button again. After a moment, the walking belt will begin to move at 1 mph. **When the next "chirp" is heard, the speed and incline will change to the next settings of the CD or video program.** The program can also be stopped by pressing the STOP button on your CD player or VCR.

When the CD or video program is completed, the walking belt will stop and the TIME/MIN-MILE display will begin to flash. Note: To use another CD or video program, press the START/STOP button or remove the key and go to step 1 on page 12.

Note: If the speed or incline of your treadmill does not change when a "chirp" is heard, make sure that the i-Fit.com indicator is lit and the TIME/MIN-MILE display is not flashing. Next, adjust the volume of your CD player or VCR. If the volume is too high or too low, the console may not detect the signals from your CD player or VCR. In addition, make sure that the audio cable is properly connected.

5 Follow your progress with the LED track and the four displays.

See step 5 on page 10.

6 Measure your pulse, if desired.

See step 6 on page 11.

7 When the i-Fit.com CD or video is finished, remove the key.

Step onto the foot rails and remove the key from the console. Keep the key in a secure place.

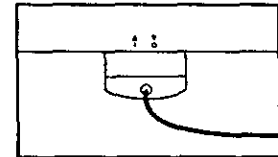

Note: If the displays and various indicators on the console remain lit after the key is removed, the console is in the "demo" mode. Refer to page 14 and turn off the demo mode.

CAUTION: Always remove i-Fit.com CD's and videos from your CD player or VCR when you are finished using them.

When you are finished using the treadmill, move the on/off switch near the power cord to the off position.

HOW TO USE OTHER I-FIT.COM TECHNOLOGY

By adding the optional upgrade module to the console, you can add virtually endless options to your treadmill. To purchase the upgrade module, visit your local department store or sporting goods store or go to www.i-fit.com.

Instructions for using other i-Fit.com options will be included with the upgrade module. In addition, **make sure to explore www.i-fit.com to learn more about how you can get the most from i-Fit.com technology!**

THE INFORMATION MODE

The console features an information mode that keeps track of the total number of hours that the treadmill has been operated and the total number of miles that the walking belt has moved. The information mode also allows you to switch the console from miles per hour to kilometers per hour.

To select the information mode, hold down the START/STOP button while inserting the key into the console. When the information mode is selected, the following information will be shown:

The DISTANCE/LAPS display will show the total number of miles that the walking belt has moved.

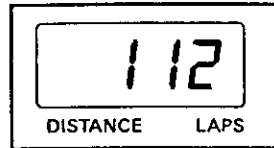

The TIME/MIN-MILE display will show the total number of hours the treadmill has been used.

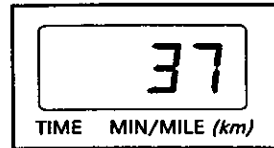

An "E," for english miles, or an "M," for metric kilometers, will appear in the SPEED display. Press the SPEED Δ button to change the unit of measurement.

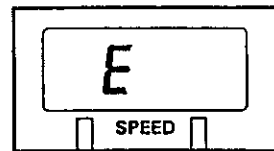

IMPORTANT: The CALS/ FAT CALS/PULSE display should be blank. If a "d" appears in the display, the console is in the "demo" mode.

This mode is intended to be used only when a treadmill is displayed in a store. When the console is in the demo mode, the power cord can be plugged in, the key can be removed from the console, and the displays and indicators on the console will automatically light in a preset sequence, although the buttons on the console will not operate. If a "d" appears in the CALS/FAT CALS/ PULSE display when the information mode is selected, press the SPEED ▽ button so the CALS/ FAT CALS/PULSE display is blank.

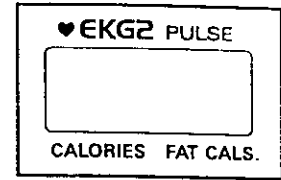
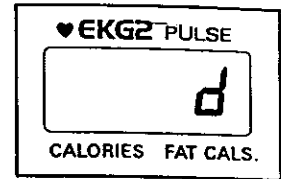

To exit the information mode, remove the key from the console.

HOW TO FOLD AND MOVE THE TREADMILL

HOW TO FOLD THE TREADMILL FOR STORAGE

Before folding the treadmill, adjust the incline to the lowest position. If this is not done, the treadmill may be permanently damaged. Next, unplug the power cord.

CAUTION: You must be able to safely lift 45 pounds (20 kg) in order to raise, lower, or move the treadmill.

1. Hold the treadmill with your hands in the locations shown at the right. **CAUTION: To decrease the possibility of injury, bend your legs and keep your back straight. As you raise the treadmill, make sure to lift with your legs rather than your back.** Raise the treadmill about halfway to the vertical position.

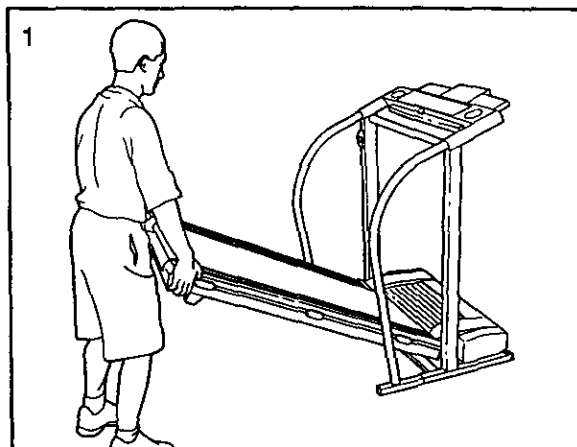

2. Move your right hand to the position shown and hold the treadmill firmly. Using your left thumb, slide the storage latch to the left and hold it. Raise the treadmill until the storage latch closes over the catch. **Make sure that the storage latch is fully closed over the latch catch.**

To protect the floor or carpet from damage, place a mat under the treadmill. Keep the treadmill out of direct sunlight. Do not leave the treadmill in the storage position in temperatures above 85° Fahrenheit.

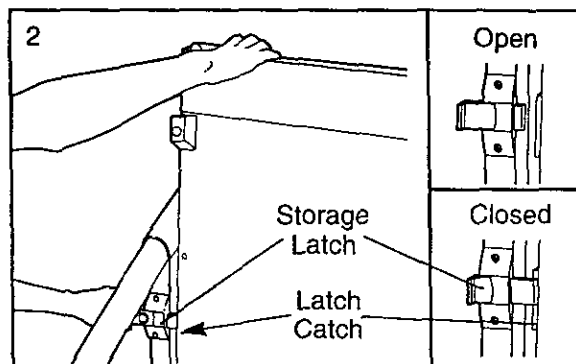

HOW TO MOVE THE TREADMILL

Before moving the treadmill, convert the treadmill to the storage position as described above. **Make sure that the storage latch is closed fully over the catch.**

1. Hold the handrails as shown and place one foot against a wheel. **Do not hold or push on the book holder or the book holder may be damaged.**
2. Tilt the treadmill back until it rolls freely on the front wheels. Carefully move the treadmill to the desired location. **Never move the treadmill without tipping it back. To reduce the risk of injury, use extreme caution while moving the treadmill. Do not attempt to move the treadmill over an uneven surface.**
3. Place one foot on the base, and carefully lower the treadmill until it is resting in the storage position.

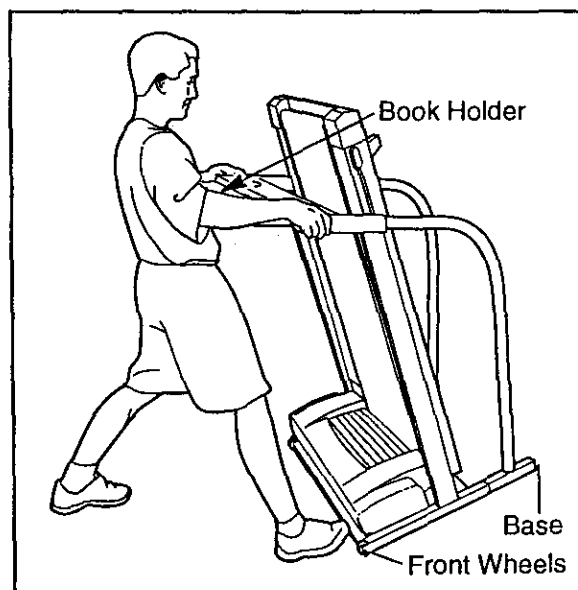

HOW TO LOWER THE TREADMILL FOR USE

1. Refer to drawing 2 above. Hold the upper end of the treadmill with your right hand as shown. Using your left thumb, slide the storage latch to the left and hold it. Pivot the treadmill down until the frame is past the storage latch.
2. Refer to drawing 1 above. Hold the treadmill firmly with both hands, and lower the treadmill to the floor. **CAUTION: To decrease the possibility of injury, bend your legs and keep your back straight.**

TROUBLE-SHOOTING

Most treadmill problems can be solved by following the simple steps below. Find the symptom that applies, and follow the steps listed. If further assistance is needed, call our toll-free HELPLINE at 1-800-736-6879, Monday through Saturday, 7 a.m. until 7 p.m. Central Time (excluding holidays).

PROBLEM: The power does not turn on

SOLUTION: a. Make sure that the power cord is plugged into a surge suppressor, and that the surge suppressor is plugged into a properly grounded outlet (see page 7). Use only a single-outlet surge suppressor that is UL 1449 listed as a transient voltage surge suppressor (TVSS). The surge suppressor must have a UL suppressed voltage rating of 400 volts or less and a minimum surge dissipation of 450 joules. The surge suppressor must be electrically rated for 120 volts AC and 15 amps.

b. After the power cord has been plugged in, make sure that the key is fully inserted into the console. See step 1 on page 10.

c. Check the circuit breaker located on the treadmill near the power cord. If the switch protrudes as shown, the circuit breaker has tripped. To reset the circuit breaker, wait for five minutes and then press the switch back in.

d. Check the on/off switch located on the treadmill near the power cord. The switch must be in the on position.

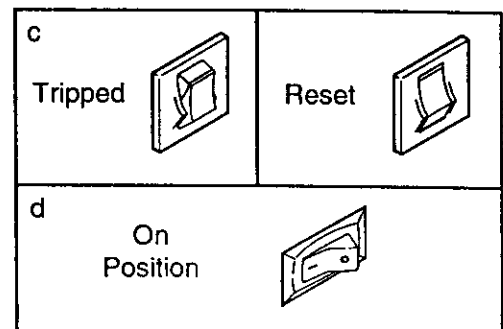

PROBLEM: The power turns off during use

SOLUTION: a. Check the circuit breaker located on the treadmill frame near the power cord (see 1. c. above). If the circuit breaker has tripped, wait for five minutes and then press the switch back in.

b. Make sure that the power cord is plugged in.

c. Remove the key from the console. Reinsert the key fully into the console. See step 1 on page 10.

d. Make sure that the on/off switch is in the on position.

e. If the treadmill still will not run, please call our toll-free HELPLINE.

PROBLEM: The displays of the console do not function properly

SOLUTION: a. Remove the key from the console and unplug the power cord. Remove the screws from the hood and carefully remove the hood. Locate the Reed Switch (21) and the Magnet (43) on the left side of the Pulley (42). Turn the Pulley until the Magnet is aligned with the Reed Switch. **Make sure that the gap between the Magnet and the Reed Switch is about 1/8".** If necessary, loosen the Reed Switch Screw (76) and move the Reed Switch slightly. Retighten the Screw. Re-attach the hood, and run the treadmill for a few minutes to check for a correct speed reading.

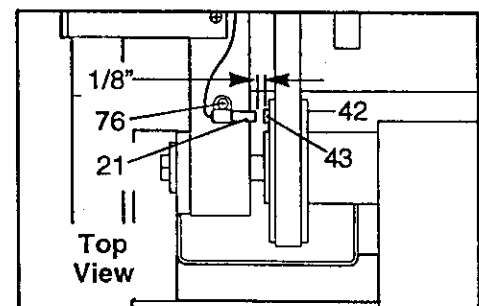

PROBLEM: The walking belt slows when walked on

SOLUTION: a. Use only a UL-listed surge protector, rated at 15 amps, with a 14-gauge cord of five feet or less in length.

b. If the walking belt is overtightened, treadmill performance may decrease and the walking belt may become damaged. Remove the key and **UNPLUG THE POWER CORD**. Using the allen wrench, turn both rear roller adjustment bolts counterclockwise, 1/4 of a turn. When the walking belt is properly tightened, you should be able to lift each side of the walking belt 3 to 4 inches off the walking platform. Be careful to keep the walking belt centered. Plug in the power cord, insert the key and run the treadmill for a few minutes. Repeat until the walking belt is properly tightened.

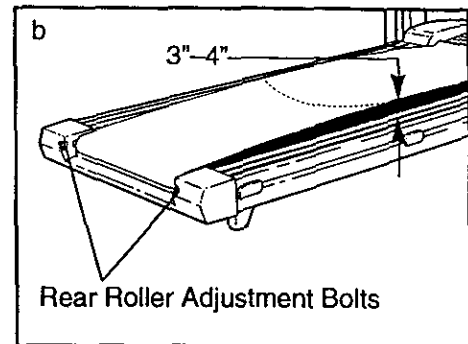

c. If the walking belt still slows when walked on, please call our toll-free HELPLINE.

PROBLEM: The walking belt is off-center

SOLUTION: a. If the walking belt has shifted to the left, first remove the key and **UNPLUG THE POWER CORD**. Using the allen wrench, turn the left rear roller adjustment bolt clockwise, and the right bolt counterclockwise, 1/4 of a turn each. Be careful not to overtighten the walking belt. Plug in the power cord, insert the key and run the treadmill for a few minutes. Repeat until the walking belt is centered.

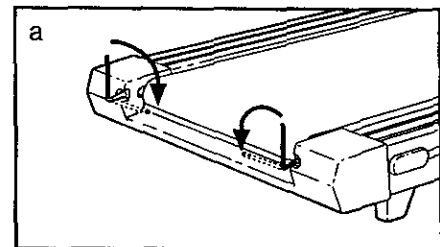

b. If the walking belt has shifted to the right, first remove the key and **UNPLUG THE POWER CORD**. Using the allen wrench, turn the left rear roller adjustment bolt counterclockwise, and the right bolt clockwise, 1/4 of a turn each. Be careful not to overtighten the walking belt. Plug in the power cord, insert the key and run the treadmill for a few minutes. Repeat until the walking belt is centered.

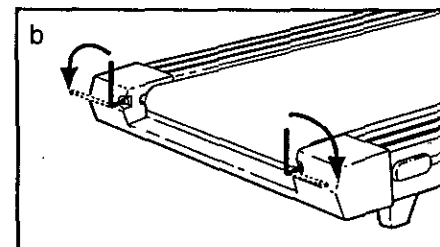

PROBLEM: The walking belt slips when walked on

SOLUTION: a. If the walking belt slips when walked on, first remove the key and **UNPLUG THE POWER CORD**. Using the allen wrench, turn both rear roller adjustment bolts clockwise, 1/4 of a turn. When the walking belt is correctly tightened, you should be able to lift each side of the walking belt 3 to 4 inches off the walking platform. Be careful to keep the walking belt centered. Plug in the power cord, insert the key and carefully walk on the treadmill for a few minutes. Repeat until the walking belt is properly tightened.

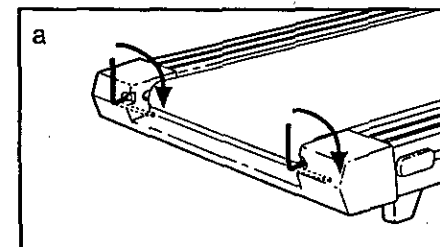

PROBLEM: The incline of the treadmill does not change correctly or does not change when i-Fit.com CD's and videos are played

SOLUTION: a. With the key inserted in the console, press one of the **INCLINE** buttons. **While the incline is changing, remove the key.** After a few seconds, re-insert the key. The treadmill will automatically rise to the maximum incline level and then return to the minimum level. This will recalibrate the incline.

CONDITIONING GUIDELINES

⚠ WARNING: Before beginning this or any exercise program, consult your physician. This is especially important for individuals over the age of 35 or individuals with pre-existing health problems.

The pulse sensor is not a medical device. Various factors, including your movement, may affect the accuracy of heart rate readings. The sensor is intended only as an exercise aid in determining heart rate trends in general.

The following guidelines will help you to plan your exercise program. Remember—these are general guidelines only. For more detailed exercise information, obtain a reputable book or consult your physician.

EXERCISE INTENSITY

Whether your goal is to burn fat or to strengthen your cardiovascular system, the key to achieving the desired results is to exercise with the proper intensity. The proper intensity level can be found by using your heart rate as a guide. The chart below shows recommended heart rates for fat burning and aerobic exercise.

	165	155	145	140	130	125	115
AEROBIC							
MAX-FAT BURN	145	138	130	125	118	110	103
FAT BURN	125	120	115	110	105	95	90
Age	20	30	40	50	60	70	80

To find the proper heart rate for you, first find your age near the bottom of the chart (ages are rounded off to the nearest ten years). Next, find the three numbers above your age. The three numbers define your "training zone." The lower two numbers are recommended heart rates for fat burning; the higher number is the recommended heart rate for aerobic exercise.

To measure your heart rate during exercise, use the pulse sensor on the console. If your heart rate is too high or too low, adjust the speed and incline of the treadmill.

Fat Burning

To burn fat effectively, you must exercise at a relatively low intensity level for a sustained period of time. During the first few minutes of exercise, your body

uses easily accessible *carbohydrate calories* for energy. Only after the first few minutes does your body begin to use stored *fat calories* for energy. If your goal is to burn fat, adjust the speed and incline of the treadmill until your heart rate is near the lowest number in your training zone.

For maximum fat burning, adjust the speed and incline of the treadmill until your heart rate is near the middle number in your training zone.

Aerobic Exercise

If your goal is to strengthen your cardiovascular system, your exercise must be "aerobic." Aerobic exercise is activity that requires large amounts of oxygen for prolonged periods of time. This increases the demand on the heart to pump blood to the muscles, and on the lungs to oxygenate the blood. For aerobic exercise, adjust the speed and incline of the treadmill until your heart rate is near the highest number in your training zone.

WORKOUT GUIDELINES

Each workout should include the following three parts:

A Warm-up—Start each workout with 5 to 10 minutes of stretching and light exercise. A proper warm-up increases your body temperature, heart rate and circulation in preparation for exercise.

Training Zone Exercise—After warming up, increase the intensity of your exercise until your pulse is in your training zone for 20 to 60 minutes. (During the first few weeks of your exercise program, do not keep your pulse in your training zone for longer than 20 minutes.) Breathe regularly and deeply as you exercise—never hold your breath.

A Cool-down—Finish each workout with 5 to 10 minutes of stretching to cool down. This will increase the flexibility of your muscles and will help prevent post-exercise problems.

Exercise Frequency

To maintain or improve your condition, complete three workouts each week, with at least one day of rest between workouts. After a few months, you may complete up to five workouts each week if desired.

The key to success is to make exercise a regular and enjoyable part of your everyday life.

PART LIST—Model No. 831.299240

R0899A

To locate the parts listed below, refer to the EXPLODED DRAWING attached in the center of this manual.

Key No.	Qty.	Description	Key No.	Qty.	Description	Key No.	Qty.	Description
1	1	Motor Belt	43	1	Magnet	85	2	Handrail
2	1	Pulley/Flywheel/Fan	44	6	Platform Screw	86	2	Wheel Bolt
3	4	Motor Nut	45	4	Isolator	87	1	Console Base
4*	1	Motor/Pulley/ Flywheel/ Fan	46	4	Isolator Screw	88	1	Console
5	2	Incline Motor Bolt	47	15	Belly Pan Fastener	89	11	3/4" Screw
6	1	Incline Motor Spacer	48	1	Shield	90	1	Key/Clip
7	1	Incline Motor	49	2	Belt Guide	91	1	Incline Motor Plate
8	1	Stop Bracket	50	1	Console Cover	92	1	Right Foot Rail Cap
9	1	Small Nut	51	1	Front Belly Pan	93	1	Book Holder
10	2	Star Washer	52	1	Power Supply	94	1	Motor Hood
11	1	Optic Switch	53	4	Cable Tie Clamp	95	2	Front Wheel
12	1	Frame	54	4	Cable Tie	96	1	Incline Motor Shield
13	1	Small Bolt	55	1	Walking Belt	97	4	Base Pad
14	1	Incline Optic Disk	56	1	20" Wire Harness	98	1	12" Audio Wire
15	8	Incline Motor Nut	57	1	Rear Roller	99	1	Upright Grommet
16	14	Screw	58	2	Rear Isolator	100	1	Allen Wrench
17	4	Plastic Stand-Off	59	2	Rear Foot	101	17	Short Screw
18	2	Hood Bracket (short)	60	2	Rear Foot Screw	102	1	Upright Hole Plug
19	2	Hood Bracket (long)	61	1	Ground Wire	103	2	Extension Leg
20	2	Warning Decal	62	7	Ground Wire Screw	104	2	Extension Leg Cap
21	1	Reed Switch	63	1	Belly Pan	105	1	Shock
22	1	Reed Switch Clip	64	1	Rear Endcap	106	1	Choke
23	1	Motor/Controller Wire	65	2	Rear Roller Adj. Bolt	107	2	Pulse Bar Bolt
24	1	Controller	66	1	Motor	108	2	Pulse Bar Washer
25	1	Electronics Bracket	67	1	Latch Decal	109	1	Pulse Bar
26	1	Circuit Breaker	68	2	Rear Platform Screw	110	2	Handrail Insert
27	1	Power Cord	69	2	Catch Screw	#	1	10" White Wire, 2F
28	1	Power Cord Grommet	70	1	Latch Catch	#	1	8" White Wire, 2F
29	1	On/Off Switch	71	1	Walking Platform	#	1	4" White Wire, M/F
30	1	Inlet Bracket	72	5	8" cable Tie	#	1	9" Wire Harness
31	1	Incline Leg	73	1	Jack	#	1	8" Blue Wire, 2F
32	2	Frame Pivot Bolt	74	1	Motor Tension Bolt	#	1	4" Blue Wire, 2F
33	2	Frame Pivot Spacer	75	1	Left Foot Rail Insert	#	1	4" Black Wire, 2F
34	1	Upright Wire Harness	76	12	Reed Switch Screw/ Belly Pan Screw	#	1	4" Green Wire, F/Ring
35	1	Front Roller Adj. Bolt	77	1	Storage Latch	#	1	8" Green Wire, F/Ring
36	5	Roller Adj. Washer	78	2	Handrail Bolt	#	1	8" Green Wire, 2 Ring
37	2	Motor Tension Nut/ Front Roller Nut	79	4	Long Screw	#	1	User's Manual
38	4	Motor Bolt	80	1	10' I-Fit Wire			
39	4	Cap Screw	81	4	Motor Star Washer			
40	1	Left Foot Rail Cap	82	1	Upright			
41	2	Foot Rail	83	2	Incline Leg Pivot Bolt			
42	1	Front Roller/Pulley	84	2	Incline Leg Pivot Washer			

* Includes all parts shown in the box

These parts are not illustrated

EXPLODED DRAWING—Model No. 831.299240

R0899A

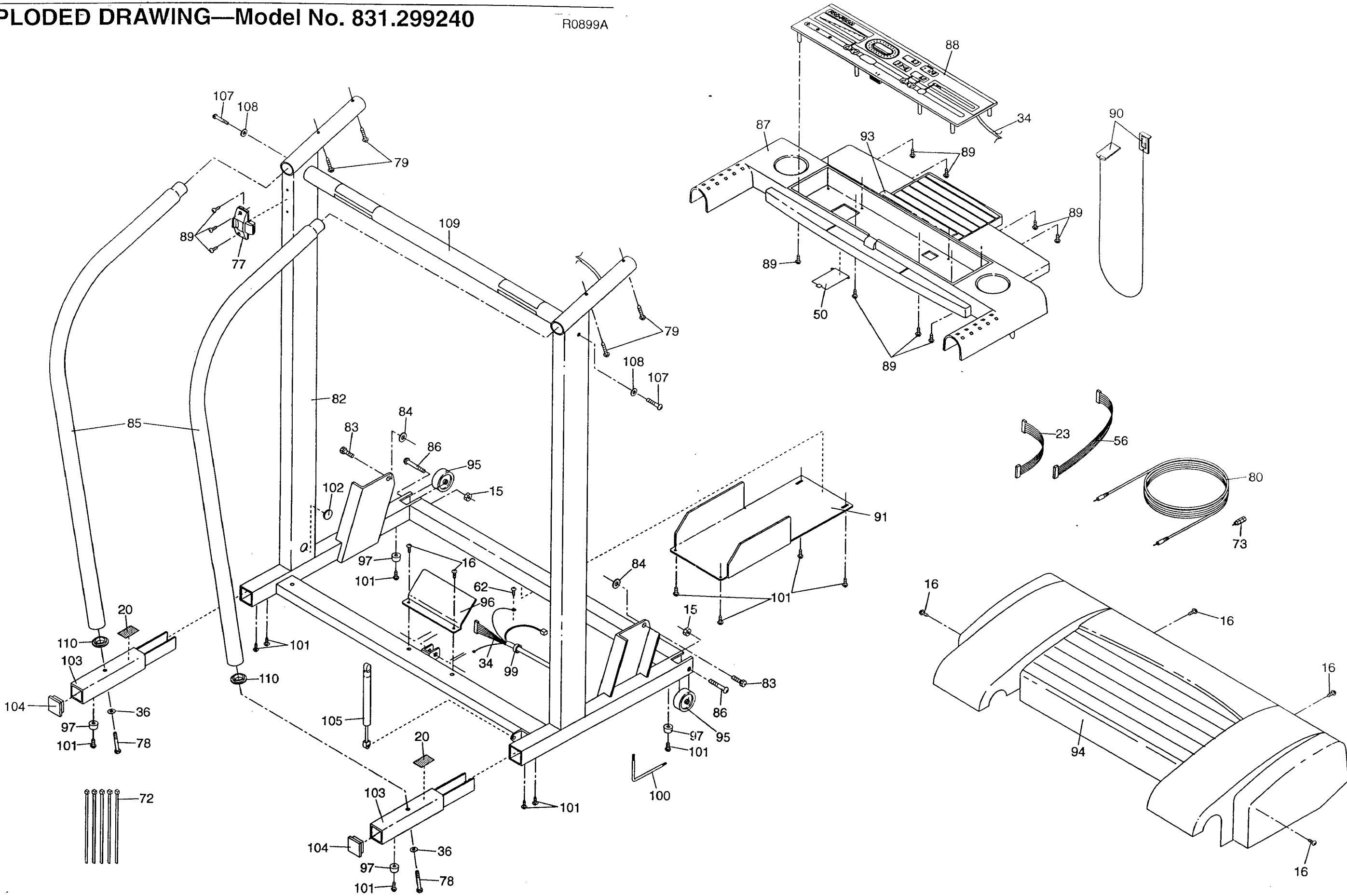

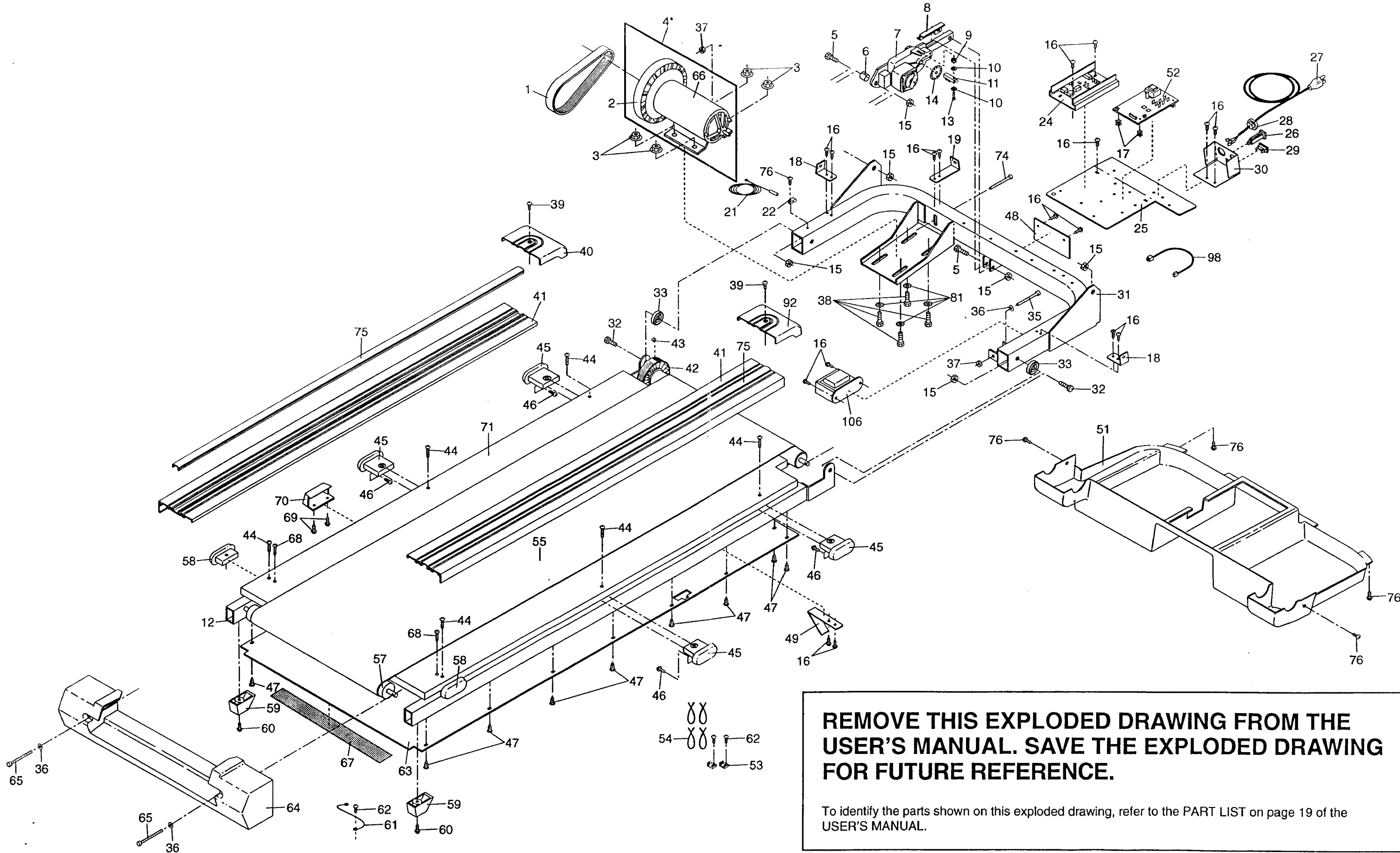

REMOVE THIS EXPLODED DRAWING FROM THE USER'S MANUAL. SAVE THE EXPLODED DRAWING FOR FUTURE REFERENCE.

To identify the parts shown on this exploded drawing, refer to the PART LIST on page 19 of the USER'S MANUAL.

SEARS

Model No. 831.299240

QUESTIONS?

If you find that:

- you need help assembling or operating the PROFORM 590QS treadmill
- a part is missing
- or you need to schedule repair service

call our toll-free HELPLINE

1-800-736-6879

Monday-Saturday, 7 am-7 pm
Central Time (excluding holidays)

REPLACEMENT PARTS

If parts become worn and need to be replaced, call the following toll-free number

**1-800-FON-PART
(1-800-366-7278)**

The model number and serial number of your PROFORM® 590QS treadmill are listed on a decal attached to the frame. See the front cover of this manual to find the location of the decal.

All replacement parts are available for immediate purchase or special order when you visit your nearest SEARS Service Center. To request service or to order parts by telephone, call the toll-free numbers listed at the left.

When requesting help or service, or ordering parts, please be prepared to provide the following information:

- The NAME OF THE PRODUCT (PROFORM® 590QS treadmill)
- The MODEL NUMBER OF THE PRODUCT (831.299240)
- The KEY NUMBER AND DESCRIPTION OF THE PART (see the EXPLODED DRAWING and PART LIST included in this manual)

FULL 90 DAY WARRANTY

For 90 days from the date of purchase, if failure occurs due to defect in material or workmanship in this SEARS TREADMILL EXERCISER, contact the nearest SEARS Service Center throughout the United States and SEARS will repair or replace the TREADMILL EXERCISER, free of charge.

This warranty does not apply when the TREADMILL EXERCISER is used commercially or for rental purposes.

This warranty gives you specific legal rights, and you may also have other rights which vary from state to state.

SEARS, ROEBUCK AND CO., DEPT. 817WA, HOFFMAN ESTATES, IL 60179