

Owner's Manual

**CRAFTSMAN®**

**20.5HP**

**ELECTRIC START**

**42" MOWER**

**6 SPEED TRANSAXLE**

**LAWN TRACTOR**

**EZ<sup>3</sup>**

Model No.  
**917.270850**

- Safety
- Assembly
- Operation
- Maintenance
- Repair Parts

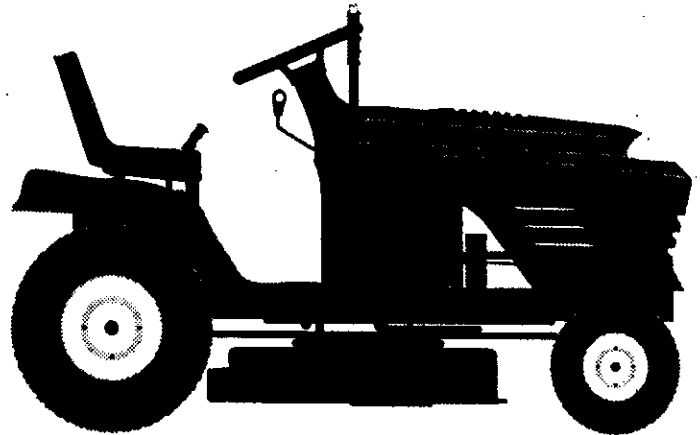

This product has a low emission engine which operates differently from previously built engines. Before you start the engine, read and understand this Owner's Manual.

**CAUTION:**

Read and follow all Safety Rules and Instructions before operating this equipment.

For answers to your questions about this product, Call:

**1-800-659-5917**

Sears Craftsman Help Line  
5 am - 5 pm, Mon - Sat

Sears, Roebuck and Co., Hoffman Estates, IL 60179

Visit our Craftsman website: [www.sears.com/craftsman](http://www.sears.com/craftsman)

## TABLE OF CONTENTS

Warranty .....	2	Maintenance .....	17
Safety Rules .....	2	Service and Adjustments .....	21
Product Specifications .....	5	Storage .....	27
Assembly .....	8	Troubleshooting .....	28
Operation .....	11	Repair Parts .....	32
Maintenance Schedule .....	17	Parts Ordering .....	Back Cover

## WARRANTY

### LIMITED TWO YEAR WARRANTY ON CRAFTSMAN RIDING EQUIPMENT

For two (2) years from the date of purchase, if this Craftsman Riding Equipment is maintained, lubricated and tuned up according to the instructions in the owner's manual, Sears will repair or replace, free of charge, any parts found to be defective in material or workmanship.

This Warranty does not cover:

- Expendable items which become worn during normal use, such as blades, spark plugs, air cleaners, belts, etc.
- Tire replacement or repair caused by punctures from outside objects, such as nails, thorns, stumps, or glass.
- Repairs necessary because of operator abuse, negligence, improper storage or accident or the failure to maintain the equipment according to the instructions contained in the owner's manual.
- Riding equipment used for commercial or rental purposes.

### LIMITED 90 DAY WARRANTY ON BATTERY

For ninety (90) days from date of purchase, if any battery included with this riding equipment proves defective in material or workmanship and our testing determines the battery will not hold a charge, Sears will replace the battery at no charge. In-home warranty service on your Craftsman riding equipment is available at no charge for 30 days from the date of purchase. Please contact your nearest service center. After 30 days from the date of purchase, warranty service is available by taking your Craftsman riding equipment to your nearest Sears Service Center. (In-home warranty service will still be available after 30 days from the date of purchase but a standard trip charge will apply). This warranty applies only while this product is in the United States. This Warranty gives you specific legal rights, and you may also have other rights which may vary from state to state.

Sears, Roebuck and Co., D/817 WA, Hoffman Estates, IL 60179

## SAFETY RULES

**IMPORTANT:** This cutting machine is capable of amputating hands and feet and throwing objects. Failure to observe the following safety instructions could result in serious injury or death.

### GENERAL OPERATION

- Read, understand, and follow all instructions in the manual and on the machine before starting.
- Only allow responsible adults, who are familiar with the instructions, to operate the machine.
- Clear the area of objects such as rocks, toys, wire, etc., which could be picked up and thrown by the blade.

- Be sure the area is clear of other people before mowing. Stop machine if anyone enters the area.
- Never carry passengers.
- Do not mow in reverse unless absolutely necessary. Always look down and behind before and while backing.
- Be aware of the mower discharge direction and do not point it at anyone. Do not operate the mower without either the entire grass catcher or the guard in place.
- Slow down before turning.
- Never leave a running machine unattended. Always turn off blades, set parking brake, stop engine, and remove keys before dismounting.

# SAFETY RULES

- Turn off blades when not mowing.
- Stop engine before removing grass catcher or unclogging chute.
- Mow only in daylight or good artificial light.
- Do not operate the machine while under the influence of alcohol or drugs.
- Watch for traffic when operating near or crossing roadways.
- Use extra care when loading or unloading the machine into a trailer or truck.

## SLOPE OPERATION

Slopes are a major factor related to loss-of-control and tipover accidents, which can result in severe injury or death. All slopes require extra caution. If you cannot back up the slope or if you feel uneasy on it, do not mow it.

### DO:

- Mow up and down slopes, not across.
- Remove obstacles such as rocks, tree limbs, etc.
- Watch for holes, ruts, or bumps. Uneven terrain could overturn the machine. Tall grass can hide obstacles.
- Use slow speed. Choose a low gear so that you will not have to stop or shift while on the slope.
- Follow the manufacturer's recommendations for wheel weights or counterweights to improve stability.
- Use extra care with grass catchers or other attachments. These can change the stability of the machine.
- Keep all movement on the slopes slow and gradual. Do not make sudden changes in speed or direction.
- Avoid starting or stopping on a slope. If tires lose traction, disengage the blades and proceed slowly straight down the slope.

### DO NOT:

- *Do not* turn on slopes unless necessary, and then, turn slowly and gradually downhill, if possible.
- *Do not* mow near drop-offs, ditches, or embankments. The mower could suddenly turn over if a wheel is over the edge of a cliff or ditch, or if an edge caves in.
- *Do not* mow on wet grass. Reduced traction could cause sliding.

- *Do not* try to stabilize the machine by putting your foot on the ground.
- *Do not* use grass catcher on steep slopes.

## CHILDREN

Tragic accidents can occur if the operator is not alert to the presence of children. Children are often attracted to the machine and the mowing activity. *Never* assume that children will remain where you last saw them.

- Keep children out of the mowing area and under the watchful care of another responsible adult.
- Be alert and turn machine off if children enter the area.
- Before and when backing, look behind and down for small children.
- Never carry children. They may fall off and be seriously injured or interfere with safe machine operation.
- Never allow children to operate the machine.
- Use extra care when approaching blind corners, shrubs, trees, or other objects that may obscure vision.

## SERVICE

- Use extra care in handling gasoline and other fuels. They are flammable and vapors are explosive.
  - Use only an approved container.
  - Never remove gas cap or add fuel with the engine running. Allow engine to cool before refueling. Do not smoke.
  - Never refuel the machine indoors.
  - Never store the machine or fuel container inside where there is an open flame, such as a water heater.
- Never run a machine inside a closed area.
- Keep nuts and bolts, especially blade attachment bolts, tight and keep equipment in good condition.
- Never tamper with safety devices. Check their proper operation regularly.
- Keep machine free of grass, leaves, or other debris build-up. Clean oil or fuel spillage. Allow machine to cool before storing.
- Stop and inspect the equipment if you strike an object. Repair, if necessary, before restarting.

## SAFETY RULES

- Never make adjustments or repairs with the engine running.
- Grass catcher components are subject to wear, damage, and deterioration, which could expose moving parts or allow objects to be thrown. Frequently check components and replace with manufacturer's recommended parts, when necessary.
- Mower blades are sharp and can cut. Wrap the blade(s) or wear gloves, and use extra caution when servicing them.
- Check brake operation frequently. Adjust and service as required.
- Be sure the area is clear of other people before mowing. Stop machine if anyone enters the area.



- Never carry passengers.
- Do not mow in reverse unless absolutely necessary. Always look down and behind before and while backing.
- Never carry children. They may fall off and be seriously injured or interfere with safe machine operation.
- Keep children out of the mowing area and under the watchful care of another responsible adult.
- Be alert and turn machine off if children enter the area.
- Before and when backing, look behind and *down* for small children.
- Mow up and down slopes (15° Max), not across.
- Remove obstacles such as rocks, tree limbs, etc.
- Watch for holes, ruts, or bumps. Uneven terrain could overturn the machine. *Tall grass can hide obstacles.*
- Use slow speed. Choose a low gear so that you will not have to stop or shift while on the slope.
- Avoid starting or stopping on a slope. If tires lose traction, disengage the blades and proceed slowly *straight* down the slope.
- *Do not* turn on slopes unless necessary, and then, turn slowly and gradually downhill, if possible.

**⚠** Look for this symbol to point out important safety precautions. It means **CAUTION!!! BECOME AWARE!!! YOUR SAFETY IS INVOLVED.**

**⚠ WARNING:** The engine exhaust from this product contains chemicals known to the State of California to cause cancer, birth defects, or other reproductive harm.

**⚠ CAUTION:** In order to prevent accidental starting when setting up, transporting, adjusting or making repairs always disconnect spark plug wire and place wire where it cannot contact spark plug.

## PRODUCT SPECIFICATIONS

GASOLINE CAPACITY AND TYPE:	3.5 GALLONS UNLEADED REGULAR
OIL TYPE (API-SF/SG/SH):	SAE 30(ABOVE 32°F) SAE 5W-30 (BELOW 32°F)
OIL CAPACITY:	3.0 PINTS
SPARK PLUG: (GAP: .030")	CHAMPION RJ19LM OR J19LM
VALVE CLEARANCE:	INTAKE: .004"-.006" EXHAUST:.007"-.009"
GROUND SPEED FORWARD: (MPH):	1ST 1.2 2ND 1.5 3RD 2.4 4TH 3.5 5TH 4.8 6TH 5.4 REVERSE: 1.5
TIRE PRESSURE:	FRONT: 14 PSI REAR: 10 PSI
CHARGING SYSTEM:	3 AMPS BATTERY 5 AMPS HEADLIGHTS
BATTERY:	AMP/HR: 30 MIN. CCA: 240 CASE SIZE:U1R
BLADE BOLT TORQUE:	27-35 FT. LBS

**CONGRATULATIONS** on your purchase of a Craftsman Tractor. It has been designed, engineered and manufactured to give you the best possible dependability and performance.

Should you experience any problem you cannot easily remedy, please contact your nearest Sears Authorized Service Center. We have competent, well-trained technicians and the proper tools to service or repair this tractor.

Please read and retain this manual. The instructions will enable you to assemble and maintain your tractor properly. Always observe the "SAFETY RULES".

## MAINTENANCE AGREEMENT

A Sears Maintenance Agreement is available on this product. Contact your nearest Sears store for details.

## CUSTOMER RESPONSIBILITIES

- Read and observe the safety rules.
- Follow a regular schedule in maintaining, caring for and using your tractor.
- Follow the instructions under "Maintenance" and "Storage" sections of this owner's manual.

**⚠ WARNING:** This tractor is equipped with an internal combustion engine and should not be used on or near any unimproved forest-covered, brush-covered or grass-covered land unless the engine's exhaust system is equipped with a spark arrester meeting applicable local or state laws (if any). If a spark arrester is used, it should be maintained in effective working order by the operator. In the state of California the above is required by law (Section 4442 of the California Public Resources Code). Other states may have similar laws. Federal laws apply on federal lands. A spark arrester for the muffler is available through your nearest Sears Authorized Service Center/Department (See REPAIR PARTS section of this manual).

# CONTENTS OF HARDWARE PACK

## Parts Bag contents shown full size

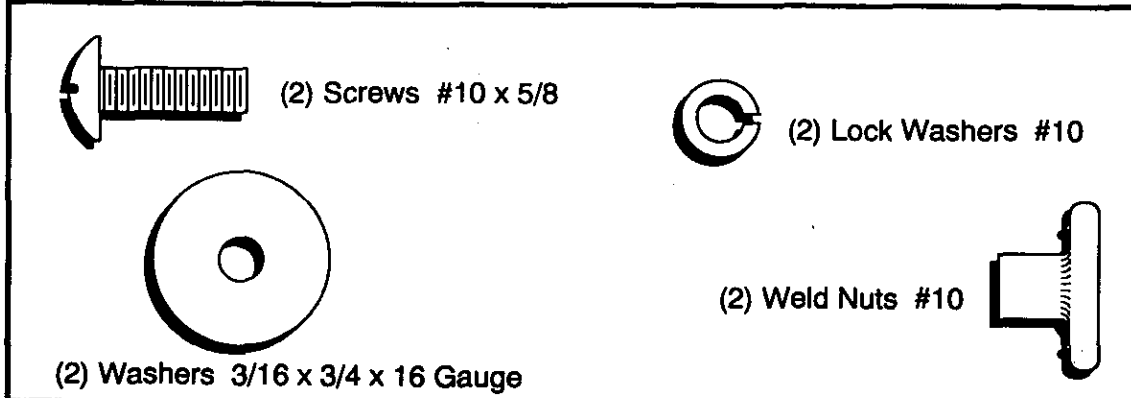
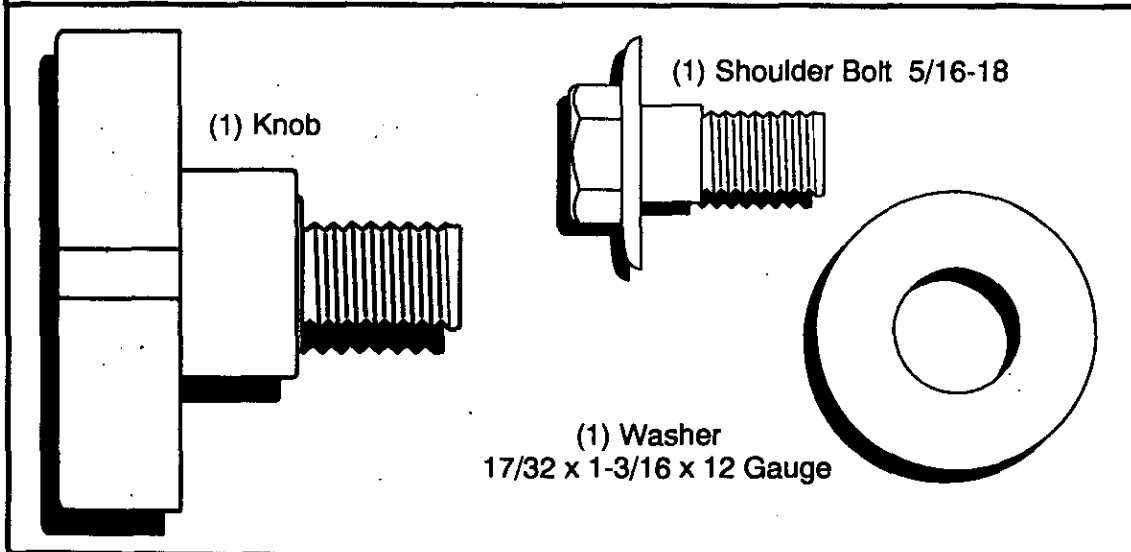
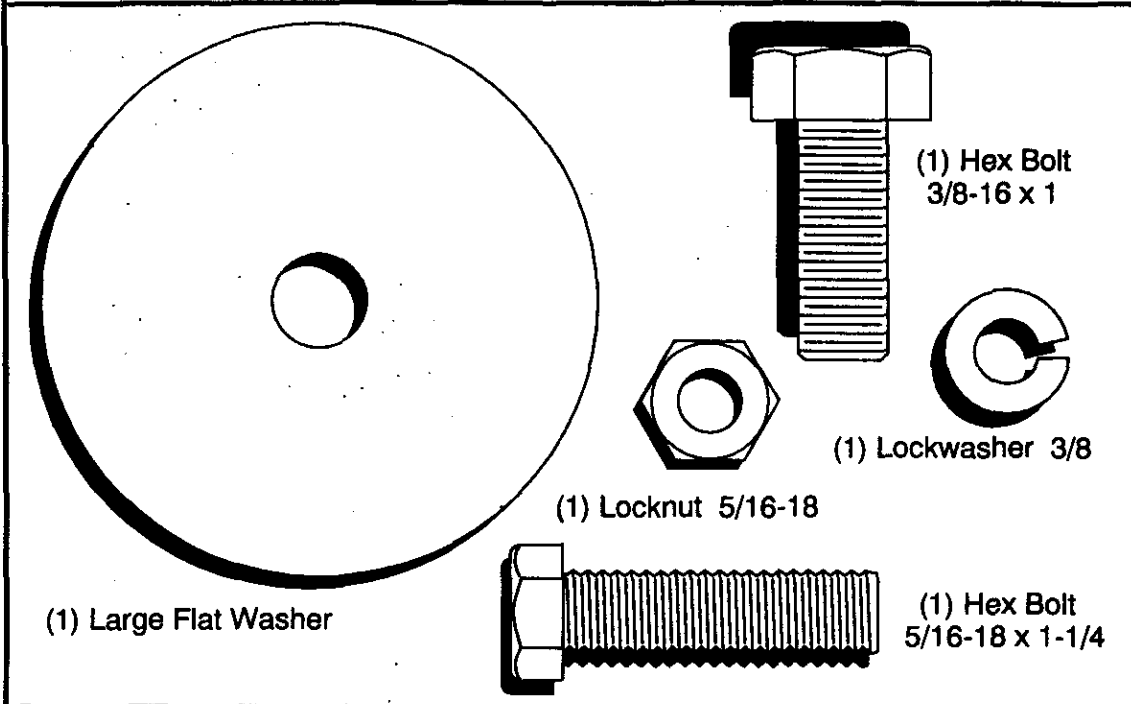

# CONTENTS OF HARDWARE PACK

## Parts packed separately in carton

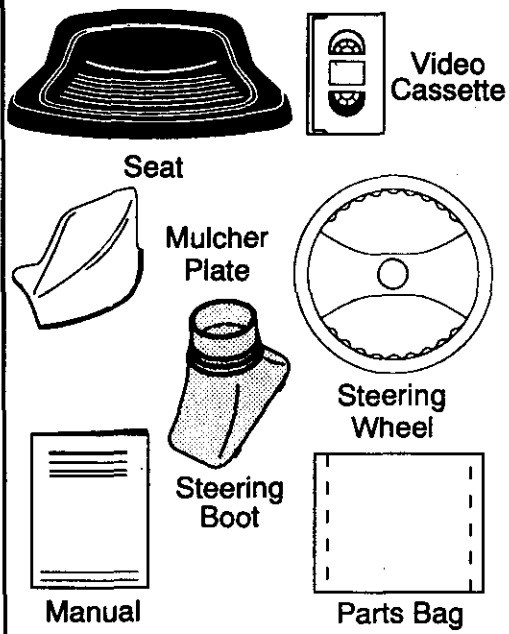

## Parts Bag contents not shown full size

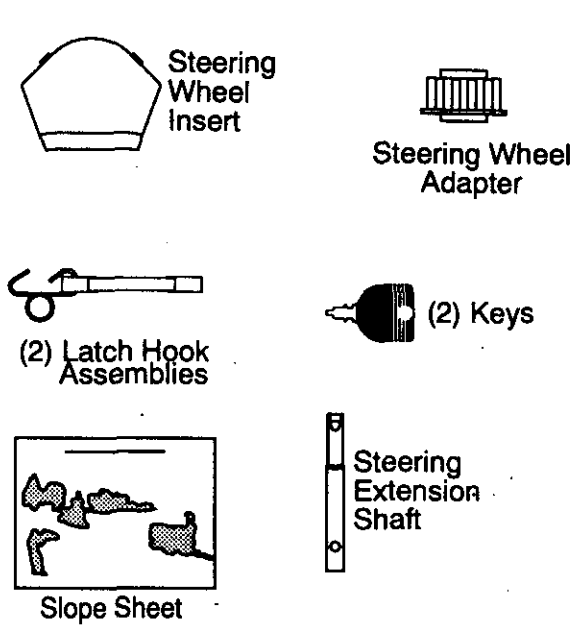

# ASSEMBLY

Your new tractor has been assembled at the factory with exception of those parts left unassembled for shipping purposes. To ensure safe and proper operation of your tractor all parts and hardware you assemble must be tightened securely. Use the correct tools as necessary to insure proper tightness. Review the video cassette before you begin.

## TOOLS REQUIRED FOR ASSEMBLY

A socket wrench set will make assembly easier. Standard wrench sizes you need are listed below.

- (1) 9/16" wrench
- (1) Pliers
- (2) 1/2" wrench
- (1) Utility knife
- (1) 3/4" socket with drive ratchet
- (1) Tire pressure gauge
- (1) Phillips screwdriver

When right or left hand is mentioned in this manual, it means, from your point of view, when you are in the operating position (seated behind the steering wheel).

## TO REMOVE TRACTOR FROM CARTON

### UNPACK CARTON

- Remove all accessible loose parts and parts boxes from shipping carton.
- Cut, from top to bottom, along lines on all four corners of shipping carton, and lay panels flat.
- Remove mower and packing materials.
- Check for any additional loose parts or boxes and remove.

## BEFORE ROLLING TRACTOR OFF SKID

### ATTACH STEERING WHEEL

### ASSEMBLE EXTENSION SHAFT AND BOOT

- Slide extension shaft onto lower steering shaft. Align mounting holes in extension and lower shafts and install 5/16 hex bolt and locknut. Tighten securely.

**IMPORTANT:** Tighten bolt and nut securely to 18-22 ft. lbs. torque.

- Place tabs of steering boot over tab slots in dash and push down to secure.

### INSTALL STEERING WHEEL

- Position front wheels of the tractor so they are pointing straight forward.
- Slide steering wheel adapter onto steering shaft extension.

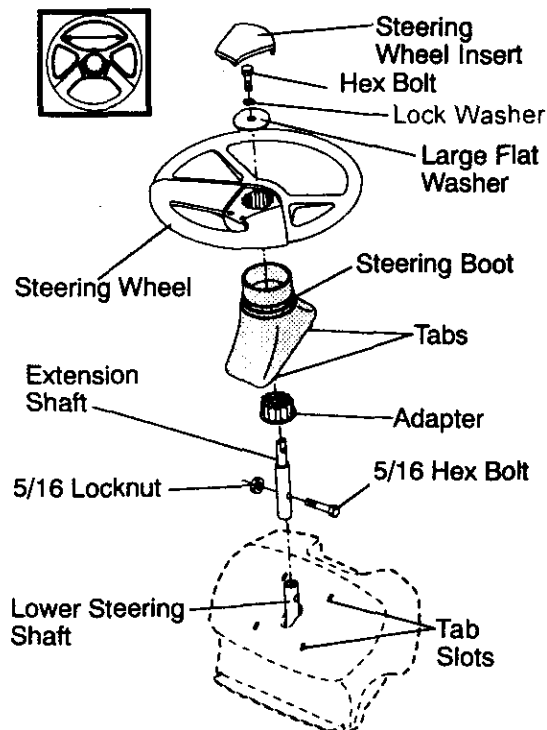

- Position steering wheel so cross bars are horizontal (left to right) and slide inside boot and onto adapter.
- Assemble large flat washer, 3/8 lock washer, 3/8 hex bolt and tighten securely.
- Snap steering wheel insert into center of steering wheel.
- Remove protective materials from tractor hood and grill.

**IMPORTANT:** Check for and remove any staples in skid that may puncture tires where tractor is to roll off skid.

## HOW TO SET UP YOUR TRACTOR

### CHECK BATTERY

- Lift hood to raised position.
- If this battery is put into service after month and year indicated on label (label located between terminals) charge battery for minimum of one hour at 6-10 amps. (See "BATTERY" in Maintenance section of this manual for charging instructions).



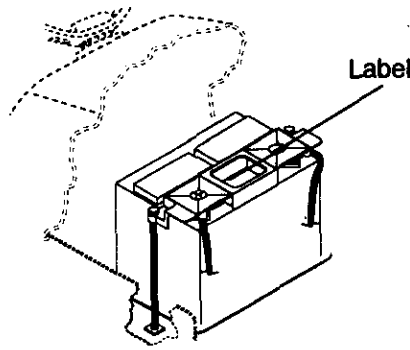

### INSTALL SEAT

Adjust seat before tightening adjustment knob.

- Remove cardboard packing on seat pan.
- Place seat on seat pan and assemble shoulder bolt. Tighten shoulder bolt securely.
- Assemble adjustment knob and flat washer loosely. Do not tighten.
- Lower seat into operating position and sit on seat.
- Slide seat until a comfortable position is reached which allows you to press clutch/brake pedal all the way down.
- Get off seat without moving its adjusted position.
- Raise seat and tighten adjustment knob securely.

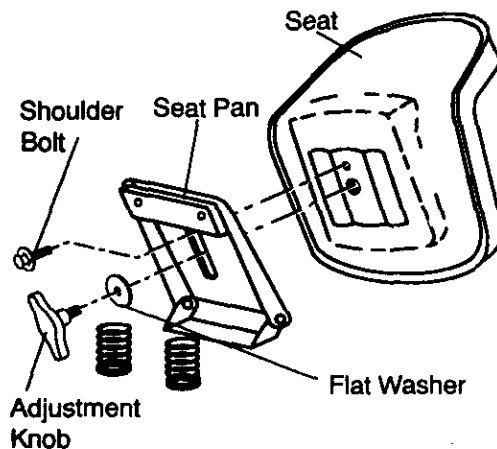

### TO ROLL TRACTOR OFF SKID (See Operation section for location and function of controls)

- Press lift lever plunger and raise attachment lift lever to its highest position.
- Release parking brake by depressing clutch/brake pedal.
- Place gearshift lever in neutral (N) position.
- Roll tractor forward off skid.

- Remove banding holding discharge guard up against tractor.

### TO DRIVE TRACTOR OFF SKID

**⚠ WARNING:** Before starting, read, understand and follow all instructions in the Operation section of this manual. Be sure tractor is in a well-ventilated area. Be sure the area in front of tractor is clear of other people and objects.

- Be sure all the above assembly steps have been completed.
  - Check engine oil level and fill fuel tank with gasoline.
  - Sit on seat in operating position, depress clutch/brake pedal and set the parking brake.
  - Place gear shift lever in neutral (N) position.
  - Press lift lever plunger and raise attachment lift lever to its highest position.
  - Start the engine. After engine has started, move throttle control to idle position.
  - Depress clutch/brake pedal into full "BRAKE" position and hold. Move gearshift lever to 1st gear.
  - Slowly release clutch/brake pedal and slowly drive tractor off skid.
  - Apply brake to stop tractor, set parking brake and place gearshift lever in neutral position.
  - Turn ignition key to "OFF" position.
- Continue with the instructions that follow.

### INSTALL MULCHER PLATE

- Install two latch hooks to mulcher plate using screw, washer, lock washer, and weld nut as shown.

**NOTE:** Pre-assemble weld nut to latch hook by inserting weld nut from the top with hook pointing down.

- Tighten hardware securely.
- Raise and hold deflector shield in upright position.
- Place front of mulcher plate over front of mower deck opening and slide into place, as shown.
- Hook front latch into hole on front of mower deck.
- Hook rear latch into hole on back of mower deck.

**⚠ CAUTION:** Do not remove discharge guard from mower. Raise and hold guard when attaching mulcher plate and allow it to rest on plate while in operation.

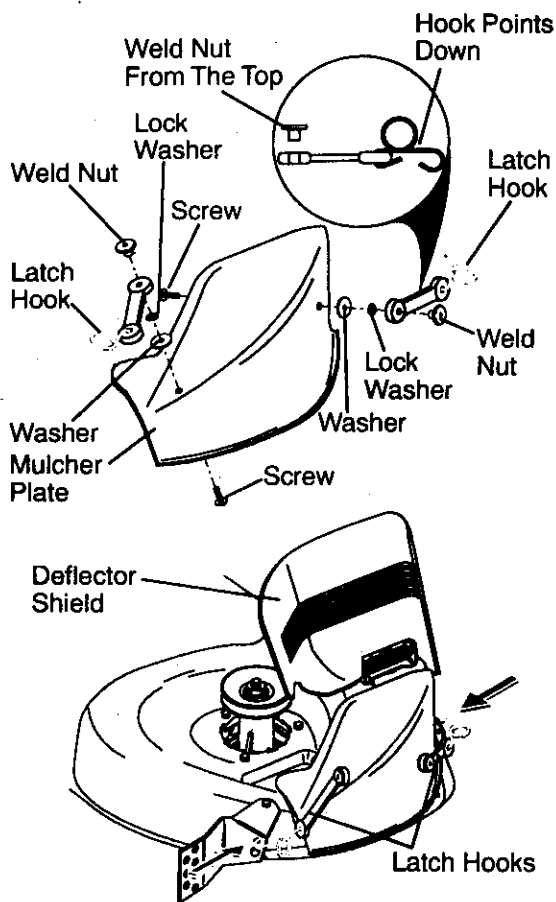

### TO CONVERT TO BAGGING OR DISCHARGING

Simply remove mulcher plate and store in a safe place. Your mower is now ready for discharging or installation of optional grass catcher accessory.

**NOTE:** It is not necessary to change blades. The mulcher blades are designed for discharging and bagging also.

### CHECK TIRE PRESSURE

The tires on your tractor were overinflated at the factory for shipping purposes. Correct tire pressure is important for best cutting performance.

- Reduce tire pressure to PSI shown in "PRODUCT SPECIFICATIONS" section of this manual.

### CHECK DECK LEVELNESS

For best cutting results, mower housing should be properly leveled. See "TO LEVEL MOWER HOUSING" in the Service and Adjustments section of this manual.

### CHECK FOR PROPER POSITION OF ALL BELTS

See the figures that are shown for replacing motion and mower blade drive belts in the Service and Adjustments section of this manual. Verify that the belts are routed correctly.

### CHECK BRAKE SYSTEM

After you learn how to operate your tractor, check to see that the brake is properly adjusted. See "TO ADJUST BRAKE" in the Service and Adjustments section of this manual.

### ✓ CHECKLIST

BEFORE YOU OPERATE AND ENJOY YOUR NEW TRACTOR, WE WISH TO ASSURE THAT YOU RECEIVE THE BEST PERFORMANCE AND SATISFACTION FROM THIS QUALITY PRODUCT.

PLEASE REVIEW THE FOLLOWING CHECKLIST:

- ✓ All assembly instructions have been completed.
- ✓ No remaining loose parts in carton.
- ✓ Battery is properly prepared and charged. (Minimum 1 hour at 6 amps).
- ✓ Seat is adjusted comfortably and tightened securely.
- ✓ All tires are properly inflated. (For shipping purposes, the tires were overinflated at the factory).
- ✓ Be sure mower deck is properly leveled side-to-side/front-to-rear for best cutting results. (Tires must be properly inflated for leveling).
- ✓ Check mower and drive belts. Be sure they are routed properly around pulleys and inside all belt keepers.
- ✓ Check wiring. See that all connections are still secure and wires are properly clamped.

WHILE LEARNING HOW TO USE YOUR TRACTOR, PAY EXTRA ATTENTION TO THE FOLLOWING IMPORTANT ITEMS:

- ✓ Engine oil is at proper level.
- ✓ Fuel tank is filled with fresh, clean, regular unleaded gasoline.
- ✓ Become familiar with all controls - their location and function. Operate them before you start the engine.
- ✓ Be sure brake system is in safe operating condition.

# OPERATION

These symbols may appear on your tractor or in literature supplied with the product. Learn and understand their meaning.



BATTERY



CAUTION OR WARNING



REVERSE



FORWARD



FAST



SLOW



ENGINE ON



ENGINE OFF



OIL PRESSURE



LIGHTS ON



OVER TEMP LIGHT

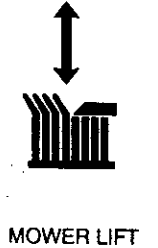

MOWER LIFT



FUEL



CHOKE



MOWER HEIGHT



PARKING BRAKE LOCKED



UNLOCKED



ATTACHMENT CLUTCH ENGAGED

R

REVERSE

N

NEUTRAL

H

HIGH

L

LOW



PARKING BRAKE



IGNITION



ATTACHMENT CLUTCH DISENGAGED



KEEP AREA CLEAR



SLOPE HAZARDS

(SEE SAFETY RULES SECTION)

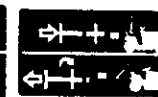

FREE WHEEL  
(Automatic Models only)

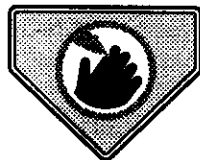

DANGER, KEEP HANDS AND FEET AWAY

## KNOW YOUR TRACTOR

### READ THIS OWNER'S MANUAL AND SAFETY RULES BEFORE OPERATING YOUR TRACTOR

Compare the illustrations with your tractor to familiarize yourself with the locations of various controls and adjustments. Save this manual for future reference.

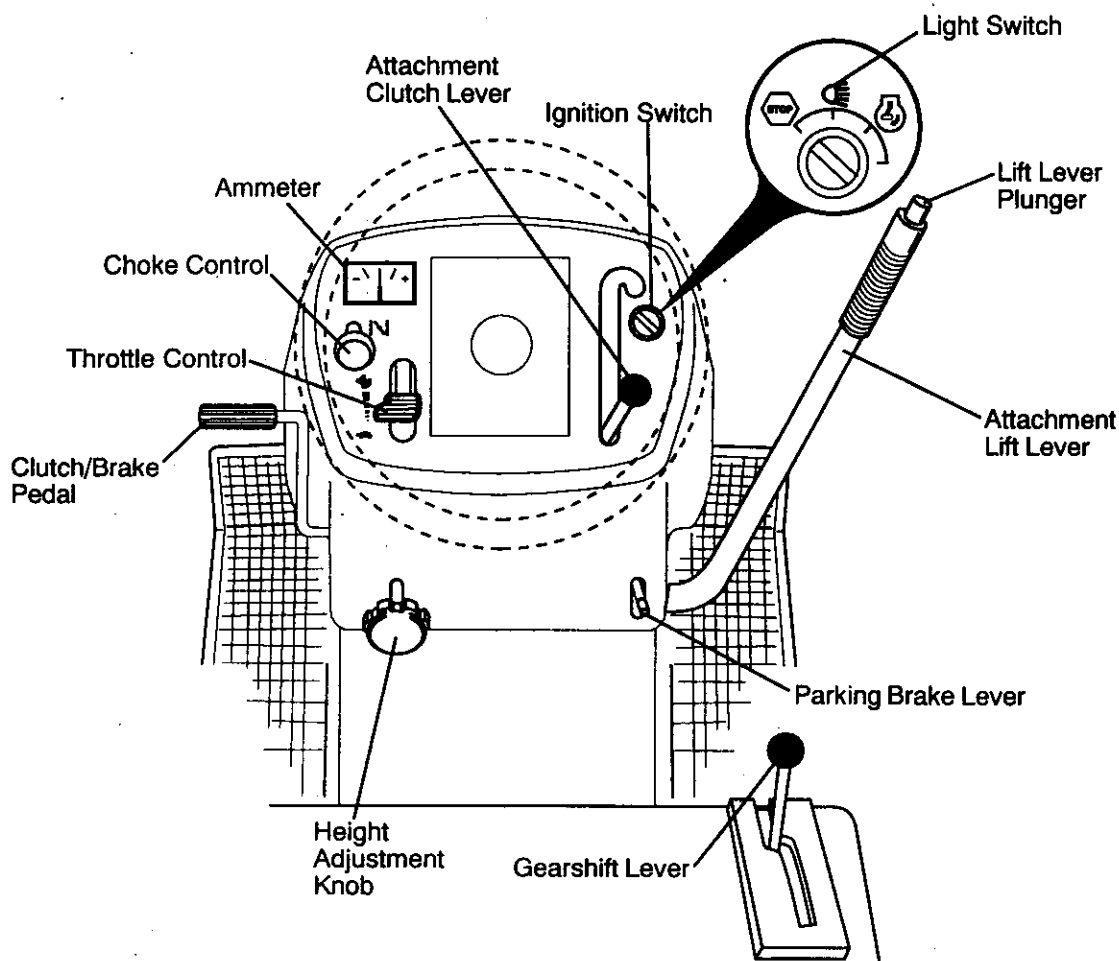

---

Our tractors conform to the safety standards of the American National Standards Institute.

---

**AMMETER** - Indicates charging (+) or discharging (-) of battery.

**ATTACHMENT CLUTCH LEVER** - Used to engage the mower blades, or other attachments mounted to your tractor.

**ATTACHMENT LIFT LEVER** - Used to raise, lower, and adjust the mower deck or other attachments mounted to your tractor.

**CHOKE CONTROL** - Used when starting a cold engine.

**CLUTCH/BRAKE PEDAL** - Used for declutching and braking the tractor and starting the engine.

**GEARSHIFT LEVER** - Selects the speed and direction of tractor.

**HEIGHT ADJUSTMENT KNOB** - Used to adjust the mower cutting height.

**IGNITION SWITCH** - Used for starting and stopping the engine.

**LIFT LEVER PLUNGER** - Used to release attachment lift lever when changing its position.

**LIGHT SWITCH** - Turns the headlights on and off.

**PARKING BRAKE LEVER** - Locks clutch/brake pedal into the brake position.

**THROTTLE CONTROL** - Used to control engine speed.



The operation of any tractor can result in foreign objects thrown into the eyes, which can result in severe eye damage. Always wear safety glasses or eye shields while operating your tractor or performing any adjustments or repairs. We recommend a wide vision safety mask over spectacles or standard safety glasses.

## HOW TO USE YOUR TRACTOR TO SET PARKING BRAKE

Your tractor is equipped with an operator presence sensing switch. When engine is running, any attempt by the operator to leave the seat without first setting the parking brake will shut off the engine.

- Depress clutch/brake pedal into full "BRAKE" position and hold.
- Place parking brake lever in "ENGAGED" position and release pressure from clutch/brake pedal. Pedal should remain in "BRAKE" position. Make sure parking brake will hold tractor secure.

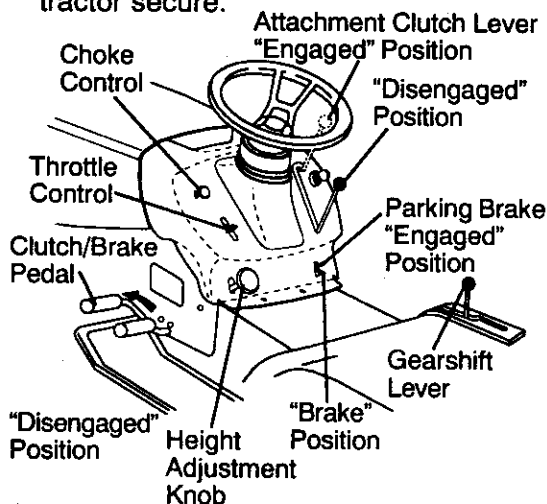

## STOPPING

### MOWER BLADES -

- To stop mower blades, move attachment clutch lever to "DISENGAGED" position.

### GROUND DRIVE -

- To stop ground drive, depress clutch/brake pedal into full "BRAKE" position.
- Move gearshift lever to neutral (N) position.

### ENGINE -

- Move throttle control to slow position.
- NOTE:** Failure to move throttle control to slow position and allowing engine to idle before stopping may cause engine to "backfire".
- Turn ignition key to "OFF" position and remove key. Always remove key when leaving tractor to prevent unauthorized use.

- Never use choke to stop engine.

**IMPORTANT:** Leaving the ignition switch in any position other than "OFF" will cause the battery to be discharged, (dead).

**NOTE:** Under certain conditions when tractor is standing idle with the engine running, hot engine exhaust gases may cause "browning" of grass. To eliminate this possibility, always stop engine when stopping tractor on grass areas.

**CAUTION:** Always stop tractor completely, as described above, before leaving the operator's position; to empty grass catcher, etc.

## TO USE THROTTLE CONTROL

Always operate engine at full throttle.

- Operating engine at less than full throttle reduces the battery charging rate.
- Full throttle offers the best bagging and mower performance.

## TO USE CHOKE CONTROL

Use choke control whenever you are starting a cold engine. Do not use to start a warm engine.

- To engage choke control, pull knob out. Slowly push knob in to disengage.

## TO MOVE FORWARD AND BACKWARD

The direction and speed of movement is controlled by the gearshift lever.

- Start tractor with clutch/brake pedal depressed and gearshift lever in neutral (N) position.
- Move gearshift lever to desired position.
- Slowly release clutch/brake pedal to start movement.

**IMPORTANT:** Bring tractor to a complete stop before shifting or changing gears. Failure to do so will shorten the useful life of your transaxle.

## TO ADJUST MOWER CUTTING HEIGHT

The cutting height is controlled by turning the height adjustment knob in desired direction.

- Turn knob clockwise (↻) to raise cutting height.

- Turn knob counterclockwise (↺) to lower cutting height.

The cutting height range is approximately 1-1/2" to 4". The heights are measured from the ground to the blade tip with the engine not running. These heights are approximate and may vary depending upon soil conditions, height of grass and types of grass being mowed.

- The average lawn should be cut to approximately 2-1/2 inches during the cool season and to over 3 inches during hot months. For healthier and better looking lawns, mow often and after moderate growth.
- For best cutting performance, grass over 6 inches in height should be mowed twice. Make the first cut relatively high; the second to desired height.

### TO ADJUST GAUGE WHEELS

Gauge wheels are properly adjusted when they are slightly off the ground when mower is at the desired cutting height in operating position. Gauge wheels then keep the deck in proper position to help prevent scalping in most terrain conditions.

- Adjust gauge wheels with tractor on a flat level surface.
- Adjust mower to desired cutting height (See "TO ADJUST MOWER CUTTING HEIGHT" in the Operation section of this manual).
- With mower in desired height of cut position, gauge wheels should be assembled so they are slightly off the ground. Install gauge wheel in appropriate hole with shoulder bolt, 3/8 washer, and 3/8-16 locknut and tighten securely.
- Repeat for opposite side installing gauge wheel in same adjustment hole.

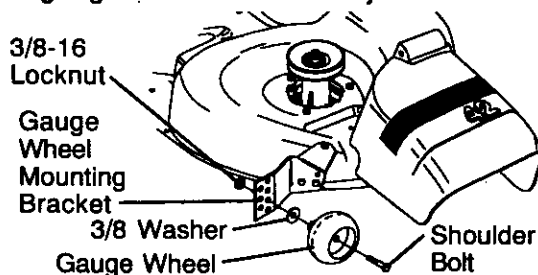

### TO OPERATE MOWER

Your tractor is equipped with an operator presence sensing switch. Any attempt by the operator to leave the seat with the engine running and the attachment clutch engaged will shut off the engine.

- Select desired height of cut.
- Lower mower with attachment lift control.
- Start mower blades by engaging attachment clutch control.
- TO STOP MOWER BLADES - disengage attachment clutch control.

**CAUTION:** Do not operate the mower without either the entire grass catcher, on mowers so equipped, or the discharge guard in place.

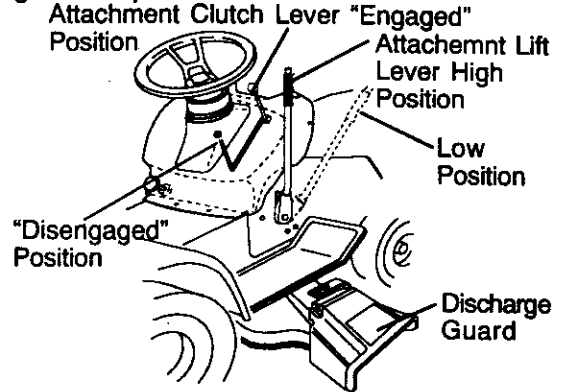

### TO OPERATE ON HILLS

**CAUTION:** Do not drive up or down hills with slopes greater than 15° and do not drive across any slope.

- Choose the slowest speed before starting up or down hills.
- Avoid stopping or changing speed on hills.
- If slowing is necessary, move throttle control lever to slower position.
- If stopping is absolutely necessary, push clutch/brake pedal quickly to brake position and engage parking brake.
- Move gearshift lever to 1st gear. Be sure you have allowed room for tractor to roll slightly as you restart movement.
- To restart movement, slowly release parking brake and clutch/brake pedal.
- Make all turns slowly.

### TO TRANSPORT

- Raise attachment lift to highest position with attachment lift control.
- When pushing or towing your tractor, be sure gearshift lever is in neutral (N) position.
- Do not push or tow tractor at more than five (5) MPH.

**NOTE:** To protect hood from damage when transporting your tractor on a truck or a trailer, be sure hood is closed and secured to tractor. Use an appropriate means of tying hood to tractor (rope, cord, etc.).

## TOWING CARTS AND OTHER ATTACHMENTS

Tow only the attachments that are recommended by and comply with specifications of the manufacturer of your tractor. Use common sense when towing. Too heavy of a load, while on a slope, is dangerous. Tires can lose traction with the ground and cause you to lose control of your tractor.

## BEFORE STARTING THE ENGINE

### CHECK ENGINE OIL LEVEL

- The engine in your tractor has been shipped, from the factory, already filled with summer weight oil.
- Check engine oil with tractor on level ground.
- Remove oil fill cap/dipstick and wipe clean, reinsert the dipstick and screw cap tight, wait for a few seconds, remove and read oil level. If necessary, add oil until "FULL" mark on dipstick is reached. Do not overfill.
- For cold weather operation you should change oil for easier starting (See "OIL VISCOSITY CHART" in the Maintenance section of this manual).
- To change engine oil, see the Maintenance section in this manual.

### ADD GASOLINE

- Fill fuel tank. Use fresh, clean, regular unleaded gasoline with a minimum of 87 octane. (Use of leaded gasoline will increase carbon and lead oxide deposits and reduce valve life). Do not mix oil with gasoline. Purchase fuel in quantities that can be used within 30 days to assure fuel freshness.

**IMPORTANT:** When operating in temperatures below 32°F(0°C), use fresh, clean winter grade gasoline to help insure good cold weather starting.

**⚠ WARNING:** Experience indicates that alcohol blended fuels (called gasohol or using ethanol or methanol) can attract moisture which leads to separation and formation of acids during storage. Acidic gas can damage the fuel system of an engine while in storage. To avoid engine problems, the fuel system should be emptied before storage of 30 days or longer. Drain the gas tank, start the engine and let it run until the fuel lines and carburetor are empty. Use fresh fuel next season. See Storage Instructions for additional information. Never use

engine or carburetor cleaner products in the fuel tank or permanent damage may occur.

**⚠ CAUTION:** Fill to bottom of gas tank filler neck. Do not overfill. Wipe off any spilled oil or fuel. Do not store, spill or use gasoline near an open flame.

### TO START ENGINE

When starting the engine for the first time or if the engine has run out of fuel, it will take extra cranking time to move fuel from the tank to the engine.

- Sit on seat in operating position, depress clutch/brake pedal and set parking brake.
- Place gear shift lever in neutral (N) position.
- Move attachment clutch to "DISENGAGED" position.
- Move throttle control to fast position
- Pull choke control out for a cold engine start attempt. For a warm engine start attempt the choke control may not be needed.

**NOTE:** Before starting, read the warm and cold starting procedures below.

- Insert key into ignition and turn key clockwise to "START" position and release key as soon as engine starts. Do not run starter continuously for more than fifteen seconds per minute. If the engine does not start after several attempts, push choke control in, wait a few minutes and try again. If engine still does not start, pull the choke control out and retry.

### WARM WEATHER STARTING (50° F and above)

- When engine starts, slowly push choke control in until the engine begins to run smoothly. If the engine starts to run roughly, pull the choke control out slightly for a few seconds and then continue to push the control in slowly.
- The attachments and ground drive can now be used. If the engine does not accept the load, restart the engine and allow it to warm up for one minute using the choke as described above.

### COLD WEATHER STARTING (50° F and below)

- When engine starts, slowly push choke control in until the engine begins to run smoothly. Continue to push the choke control in small steps allowing the engine to accept small changes in speed and load, until the choke control is fully in. If the engine starts to run roughly, pull the choke

control out slightly for a few seconds and then continue to push the control in slowly. This may require an engine warm-up period from several seconds to several minutes, depending on the temperature.

- The attachments can be used during the engine warm-up period and may require the choke control be pulled out slightly.

**NOTE:** If at a high altitude (above 3000 feet) or in cold temperatures (below 32 F) the carburetor fuel mixture may need to be adjusted for best engine performance. See "TO ADJUST CARBURETOR" in the Service and Adjustments section of this manual.

### MOWING TIPS

- Tire chains cannot be used when the mower housing is attached to tractor.
- Mower should be properly leveled for best mowing performance. See "TO LEVEL MOWER HOUSING" in the Service and Adjustments section of this manual.
- The left hand side of mower should be used for trimming.
- Drive so that clippings are discharged onto the area that has been cut. Have the cut area to the right of the tractor. This will result in a more even distribution of clippings and more uniform cutting.
- When mowing large areas, start by turning to the right so that clippings will discharge away from shrubs, fences, driveways, etc. After one or two rounds, mow in the opposite direction making left hand turns until finished.
- If grass is extremely tall, it should be mowed twice to reduce load and possible fire hazard from dried clippings. Make first cut relatively high; the second to the desired height.
- Do not mow grass when it is wet. Wet grass will plug mower and leave undesirable clumps. Allow grass to dry before mowing.
- Always operate engine at full throttle when mowing to assure better mowing performance and proper discharge of material. Regulate ground speed by selecting a low enough gear to give the mower cutting performance as well as the quality of cut desired.
- When operating attachments, select a ground speed that will suit the terrain and give best performance of the attachment being used.

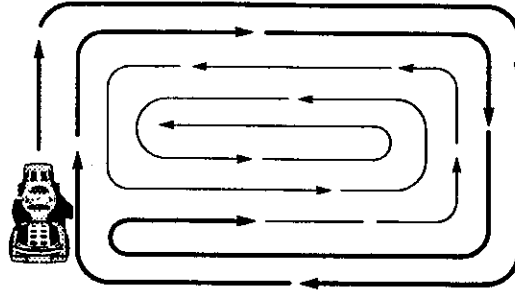

### MULCHING MOWING TIPS

**IMPORTANT:** For best performance, keep mower housing free of built-up grass and trash. Clean after each use.

- The special mulching blade will recut the grass clippings many times and reduce them in size so that as they fall onto the lawn they will disperse into the grass and not be noticed. Also, the mulched grass will biodegrade quickly to provide nutrients for the lawn. Always mulch with your highest engine (blade) speed as this will provide the best recutting action of the blades.
- Avoid cutting your lawn when it is wet. Wet grass tends to form clumps and interferes with the mulching action. The best time to mow your lawn is the early afternoon. At this time the grass has dried and the newly cut area will not be exposed to the direct sun.
- For best results, adjust the mower cutting height so that the mower cuts off only the top one-third of the grass blades. For extremely heavy mulching, reduce your width of cut on each pass and mow slowly.
- Certain types of grass and grass conditions may require that an area be mulched a second time to completely hide the clippings. When doing a second cut, mow across or perpendicular to the first cut path.
- Change your cutting pattern from week to week. Mow north to south one week then change to east to west the next week. This will help prevent matting and graining of the lawn.

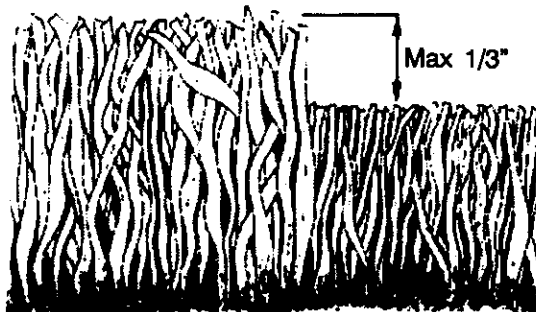



# MAINTENANCE

<b>MAINTENANCE SCHEDULE</b>		BEFORE EACH USE							BEFORE STORAGE									
FILL IN DATES AS YOU COMPLETE REGULAR SERVICE		EVERY 8 HOURS		EVERY 25 HOURS		EVERY 50 HOURS		EVERY 100 HOURS		EVERY SEASON		SERVICE DATES						
<b>T R A C T O R</b>	Check Brake Operation	✓	✓															
	Check Tire Pressure	✓	✓															
	Check Operator Presence and Interlock Systems	✓																
	Check for Loose Fasteners	✓						✓ <sub>7</sub>		✓								
	Sharpen/Replace Mower Blades			✓ <sub>4</sub>														
	Lubrication Chart			✓						✓								
	Check Battery Level			✓ <sub>6</sub>							✓							
	Clean Battery and Terminals			✓							✓							
	Check Transaxle Cooling			✓														
	Adjust Blade Belt(s) Tension							✓ <sub>5</sub>										
	Adjust Motion Drive Belt(s) Tension							✓ <sub>5</sub>										
<b>E N G I N E</b>	Check Engine Oil Level	✓	✓															
	Change Engine Oil			✓ <sub>1,2,3</sub>						✓								
	Clean Air Filter			✓ <sub>2</sub>														
	Clean Air Screen			✓ <sub>2</sub>														
	Inspect Muffler/Spark Arrester					✓												
	Replace Oil Filter (if equipped)							✓ <sub>1,2</sub>										
	Clean Engine Cooling Fins							✓ <sub>2</sub>										
	Replace Spark Plug							✓		✓								
	Replace Air Filter Paper Cartridge							✓ <sub>2</sub>										
	Replace Fuel Filter									✓								

- 1 - Change more often when operating under a heavy load or in high ambient temperatures.  
 2 - Service more often when operating in dirty or dusty conditions.  
 3 - If equipped with oil filter, change oil every 50 hours.  
 4 - Replace blades more often when mowing in sandy soil.  
 5 - If equipped with adjustable system.  
 6 - Not required if equipped with maintenance-free battery.  
 7 - Tighten front axle pivot bolt to 35 ft.-lbs. maximum. Do not overtighten.

## GENERAL RECOMMENDATIONS

The warranty on this tractor does not cover items that have been subjected to operator abuse or negligence. To receive full value from the warranty, operator must maintain tractor as instructed in this manual. Some adjustments will need to be made periodically to properly maintain your tractor.

All adjustments in the Service and Adjustments section of this manual should be checked at least once each season.

- Once a year you should replace the spark plug, clean or replace air filter, and check blades and belts for wear. A new spark plug and clean air filter assure proper air-fuel mixture and help your engine run better and last longer.

## BEFORE EACH USE

- Check engine oil level.
- Check brake operation.
- Check tire pressure.
- Check operator presence and interlock systems for proper operation.
- Check for loose fasteners.

## LUBRICATION CHART

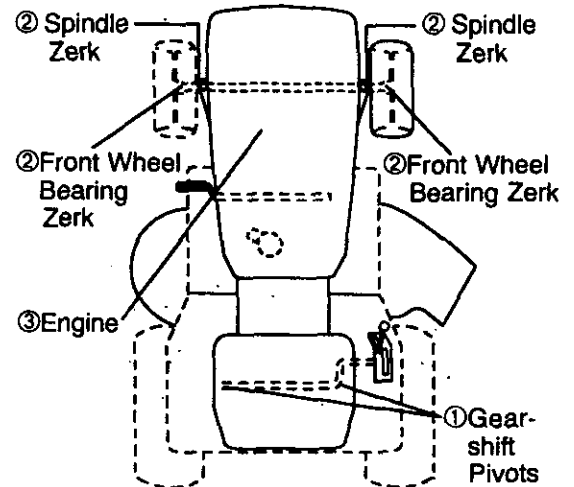

- ①SAE 30 or 10w30 MOTOR OIL
- ②GENERAL PURPOSE GREASE
- ③REFER TO Maintenance "ENGINE" SECTION

**IMPORTANT:** Do not oil or grease the pivot points which have special nylon bearings. Viscous lubricants will attract dust and dirt that will shorten the life of the self-lubricating bearings. If you feel they must be lubricated, use only a dry, powdered graphite type lubricant sparingly.

## TRACTOR

Always observe safety rules when performing any maintenance.

### BRAKE OPERATION

If tractor requires more than six (6) feet stopping distance at high speed in highest gear, then brake must be adjusted. (See "TO ADJUST BRAKE" in the Service and Adjustments section of this manual).

### TIRES

- Maintain proper air pressure in all tires (See "PRODUCT SPECIFICATIONS" section of this manual).
- Keep tires free of gasoline, oil, or insect control chemicals which can harm rubber.
- Avoid stumps, stones, deep ruts, sharp objects and other hazards that may cause tire damage.

**NOTE:** To seal tire punctures and prevent flat tires due to slow leaks, tire sealant may be purchased from your local parts dealer. Tire sealant also prevents tire dry rot and corrosion.

### OPERATOR PRESENCE SYSTEM

Be sure operator presence and interlock systems are working properly. If your tractor does not function as described, repair the problem immediately.

- The engine should not start unless the clutch/brake pedal is fully depressed and attachment clutch control is in the disengaged position.
- When the engine is running, any attempt by the operator to leave the seat without first setting the parking brake should shut off the engine.
- When the engine is running and the attachment clutch is engaged, any attempt by the operator to leave the seat should shut off the engine.
- The attachment clutch should never operate unless the operator is in the seat.

### BLADE CARE

For best results mower blades must be kept sharp. Replace bent or damaged blades.

### BLADE REMOVAL

- Raise mower to highest position to allow access to blades.
- Remove hex bolt, lock washer and flat washer securing blade.
- Install new or resharpened blade with trailing edge up towards deck as shown.

**IMPORTANT:** To ensure proper assembly, center hole in blade must align with star on mandrel assembly.

- Reassemble hex bolt, lock washer and flat washer in exact order as shown.
- Tighten bolt securely (27-35 Ft. Lbs. torque).

**IMPORTANT:** Blade bolt is Grade 8 heat treated.

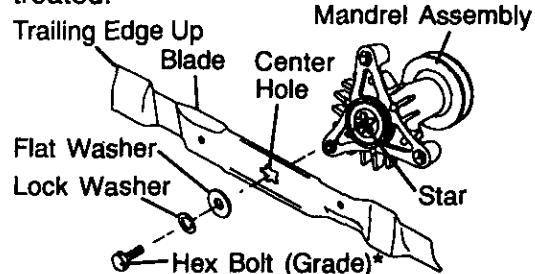

\*A Grade 8 heat treated bolt can be identified by six lines on the bolt head.

### TO SHARPEN BLADE

**NOTE:** We do not recommend sharpening blade - but if you do, be sure the blade is balanced.

Care should be taken to keep the blade balanced. An unbalanced blade will cause excessive vibration and eventual damage to mower and engine.

- The blade can be sharpened with a file or on a grinding wheel. Do not attempt to sharpen while on the mower.
- To check blade balance, you will need a 5/8" diameter steel bolt, pin, or a cone balancer. (When using a cone balancer, follow the instructions supplied with balancer.)

**NOTE:** Do not use a nail for balancing blade. The lobes of the center hole may appear to be centered, but are not.

- Slide blade on to an unthreaded portion of the steel bolt or pin and hold the bolt or pin parallel with the ground. If blade is balanced, it should remain in a horizontal position. If either end of the blade moves downward, sharpen the heavy end until the blade is balanced.

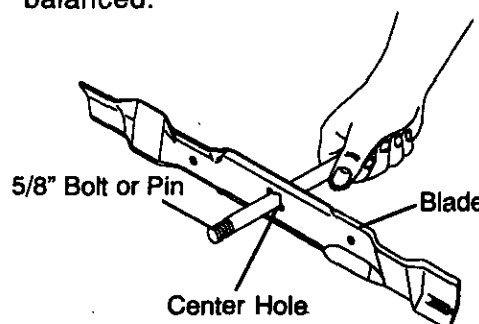

## BATTERY

Your tractor has a battery charging system which is sufficient for normal use. However, periodic charging of the battery with an automotive charger will extend its life.

- Keep battery and terminals clean.
- Keep battery bolts tight.
- Keep small vent holes open.
- Recharge at 6-10 amperes for 1 hour.

**NOTE:** The original equipment battery on your tractor is maintenance free. Do not attempt to open or remove caps or covers. Adding or checking level of electrolyte is not necessary.

### TO CLEAN BATTERY AND TERMINALS

Corrosion and dirt on the battery and terminals can cause the battery to "leak" power.

- Remove terminal guard.
- Disconnect **BLACK** battery cable first then **RED** battery cable and remove battery from tractor.
- Rinse the battery with plain water and dry.
- Clean terminals and battery cable ends with wire brush until bright.
- Coat terminals with grease or petroleum jelly.
- Reinstall battery (See "REPLACING BATTERY" in the SERVICE AND ADJUSTMENTS section of this manual).

## V-BELTS

Check V-belts for deterioration and wear after 100 hours of operation and replace if necessary. The belts are not adjustable. Replace belts if they begin to slip from wear.

## TRANSAXLE COOLING

Keep transaxle free from build-up of dirt and chaff which can restrict cooling.

## ENGINE

### LUBRICATION

Only use high quality detergent oil rated with API service classification SF, SG, or SH. Select the oil's SAE viscosity grade according to your expected operating temperature.

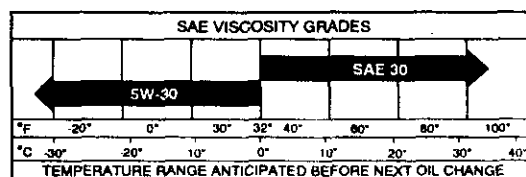

**NOTE:** Although multi-viscosity oils (5W30, 10W30 etc.) improve starting in cold weather, these multi-viscosity oils will result in increased oil consumption when used above 32°F. Check your engine oil level more frequently to avoid possible engine damage from running low on oil.

Change the oil after every 25 hours of operation or at least once a year if the tractor is not used for 25 hours in one year.

Check the crankcase oil level before starting the engine and after each eight (8) hours of operation. Tighten oil fill cap/dipstick securely each time you check the oil level.

### TO CHANGE ENGINE OIL

Determine temperature range expected before oil change. All oil must meet API service classification SF, SG or SH.

- Be sure tractor is on level surface.
- Oil will drain more freely when warm.
- Catch oil in a suitable container.
- Remove oil fill cap/dipstick. Be careful not to allow dirt to enter the engine when changing oil.
- Remove drain plug.
- After oil has drained completely, replace oil drain plug and tighten securely.
- Refill engine with oil through oil fill dipstick tube. Pour slowly. Do not overfill. For approximate capacity see "PRODUCT SPECIFICATIONS" section of this manual.
- Use gauge on oil fill cap/dipstick for checking level. Be sure dipstick cap is tightened securely for accurate reading. Keep oil at "FULL" line on dipstick.

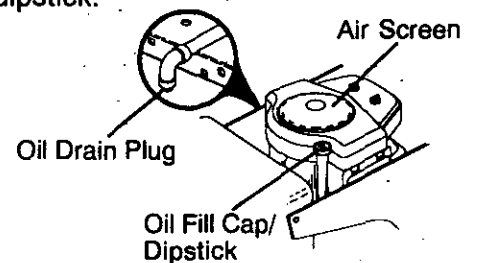

### CLEAN AIR SCREEN

Air screen must be kept free of dirt and chaff to prevent engine damage from overheating. Clean with a wire brush or compressed air to remove dirt and stubborn dried gum fibers.

## AIR FILTER

Your engine will not run properly using a dirty air filter. Clean the foam pre-cleaner after every 25 hours of operation or every season. Service paper cartridge every 100 hours of operation or every season, whichever occurs first. Service air cleaner more often under dusty conditions.

- Remove knob(s) and cover.

### TO SERVICE PRE-CLEANER

- Slide foam pre-cleaner off cartridge.
- Wash it in liquid detergent and water.
- Squeeze it dry in a clean cloth.
- Saturate it in engine oil. Wrap it in clean, absorbent cloth and squeeze to remove excess oil.
- If very dirty or damaged, replace pre-cleaner.
- Reinstall pre-cleaner over cartridge.
- Reinstall cover and secure with knob(s).

### TO SERVICE CARTRIDGE

- Remove wing nuts and cartridge plate.
- Carefully remove cartridge to prevent debris from entering carburetor.
- Clean cartridge by tapping gently on flat surface. If very dirty or damaged, replace cartridge.
- Reinstall cartridge plate, wing nuts, pre-cleaner, cover and secure with knob(s).

**IMPORTANT:** Petroleum solvents, such as kerosene, are not to be used to clean the cartridge. They may cause deterioration of the cartridge. Do not oil cartridge. Do not use pressurized air to clean or dry cartridge.

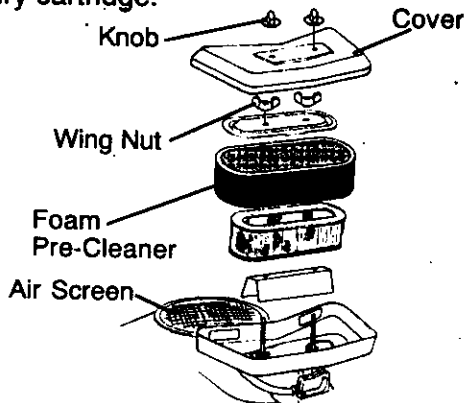

## ENGINE COOLING FINS

Remove any dust, dirt or oil from engine cooling fins to prevent engine damage from overheating. Air guide covers must be removed. Remove side panels and hood (See "TO REMOVE HOOD AND GRILL ASSEMBLY" in the Service and Adjustments section of this manual).

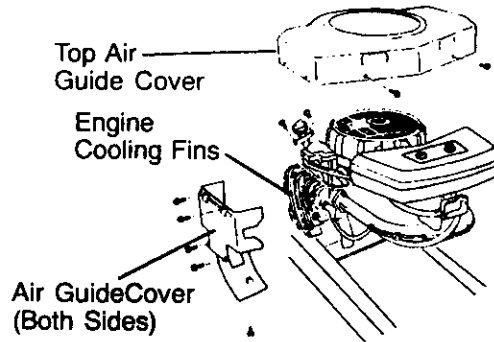

## MUFFLER

Inspect and replace corroded muffler and spark arrester (if equipped) as it could create a fire hazard and/or damage.

## SPARK PLUGS

Replace spark plugs at the beginning of each mowing season or after every 100 hours of operation, whichever occurs first. Spark plug type and gap setting are shown in "PRODUCT SPECIFICATIONS" section of this manual.

## IN-LINE FUEL FILTER

The fuel filter should be replaced once each season. If fuel filter becomes clogged, obstructing fuel flow to carburetor, replacement is required.

- With engine cool, remove filter and plug fuel line sections.
- Place new fuel filter in position in fuel line with arrow pointing towards carburetor.
- Be sure there are no fuel line leaks and clamps are properly positioned.
- Immediately wipe up any spilled gasoline.

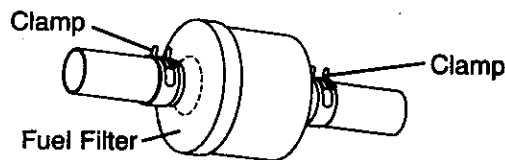

## CLEANING

- Clean engine, battery, seat, finish, etc. of all foreign matter.
- Keep finished surfaces and wheels free of all gasoline, oil, etc.
- Protect painted surfaces with automotive type wax.

We do not recommend using a garden hose to clean your tractor unless the electrical system, muffler, air filter and carburetor are covered to keep water out. Water in engine can result in a shortened engine life.

# SERVICE AND ADJUSTMENTS

**⚠ CAUTION:** Before performing any service or adjustments:

- Depress clutch/brake pedal fully and set parking brake.
- Place gearshift lever in neutral (N) position.
- Place attachment clutch in "DISENGAGED" position.
- Turn ignition key "OFF" and remove key.
- Make sure the blades and all moving parts have completely stopped.
- Disconnect spark plug wire from spark plug and place wire where it cannot come in contact with plug.

## TRACTOR

### TO REMOVE MOWER

Mower will be easier to remove from the right side of tractor.

- Place attachment clutch in "DISENGAGED" position.
- Move attachment lift lever forward to lower mower to its lowest position.
- Roll belt off engine pulley.
- Remove small retainer spring, and lift clutch spring off pulley bolt.
- Remove large retainer spring, slide collar off and push housing guide out of bracket.
- Disconnect anti-swaybar from chassis bracket by removing retainer spring.
- Disconnect suspension arms from rear deck brackets by removing retainer springs.
- Disconnect front links from deck by removing retainer springs.
- Raise lift lever to raise suspension arms. Slide mower out from under tractor.

**IMPORTANT:** If an attachment other than the mower deck is to be mounted on the tractor, remove the front links and hook the clutch spring onto square hole in frame.

### TO INSTALL MOWER

- Raise attachment lift lever to its highest position.
- Slide mower under tractor with discharge guard to right side of tractor.
- Lower lift lever to its lowest position.
- Install mower in reverse order of removal instructions.

### TO LEVEL MOWER HOUSING

Adjust the mower while tractor is parked on level ground or driveway. Make sure tires are properly inflated (See "PRODUCT SPECIFICATIONS" section of this manual). If tires are over or underinflated, you will not properly adjust your mower.

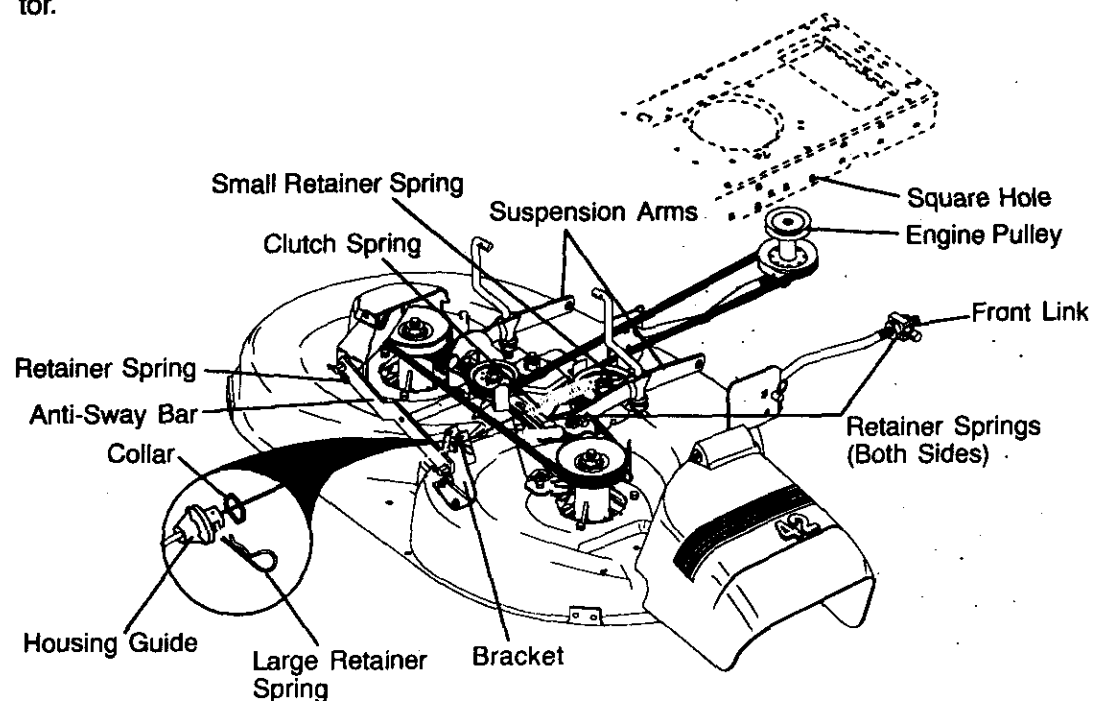

## SIDE-TO-SIDE ADJUSTMENT

- Raise mower to its highest position.
- At the midpoint of both sides of mower, measure height from bottom edge of mower to ground. Distance "A" on both sides of mower should be the same or within 1/4" of each other.
- If adjustment is necessary, make adjustment on one side of mower only.
- To raise one side of mower, tighten lift link adjustment nut on that side.
- To lower one side of mower, loosen lift link adjustment nut on that side.

**NOTE:** Each full turn of adjustment nut will change mower height about 1/8".

- Recheck measurements after adjusting.

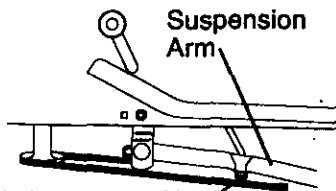
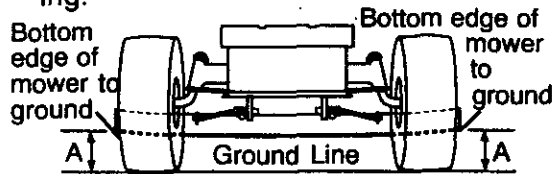

Lift Link Adjustment Nut

## FRONT-TO-BACK ADJUSTMENT

**IMPORTANT:** Deck must be level side-to-side. If the following front-to-back adjustment is necessary, be sure to adjust both front links equally so mower will stay level side-to-side.

To obtain the best cutting results, the mower housing should be adjusted so that the front is approximately 1/8" to 1/2" lower than the rear when the mower is in its highest position.

Check adjustment on right side of tractor. Measure distance "D" directly in front and behind the mandrel at bottom edge of mower housing as shown.

- Before making any necessary adjustments, check that both front links are equal in length. Both links should be approximately 10-3/8".
- If links are not equal in length, adjust one link to same length as other link.
- To lower front of mower loosen nut "E" on both front links an equal number of turns.
- When distance "D" is 1/8" to 1/2" lower at front than rear, tighten nuts "F" against trunnion on both front links.

- To raise front of mower, loosen nut "F" from trunnion on both front links. Tighten nut "E" on both front links an equal number of turns.
- When distance "D" is 1/8" to 1/2" lower at front than rear, tighten nut "F" against trunnion on both front links.
- Recheck side-to-side adjustment.

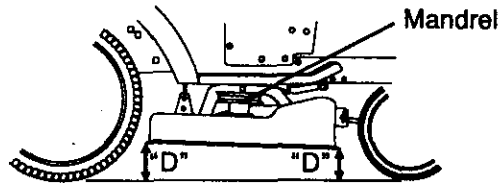

Both Front Links Should be Equal in Length

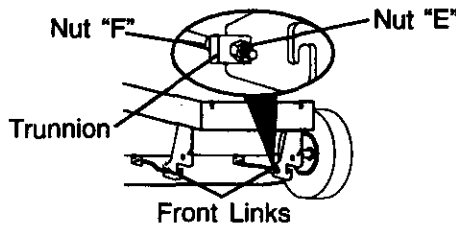
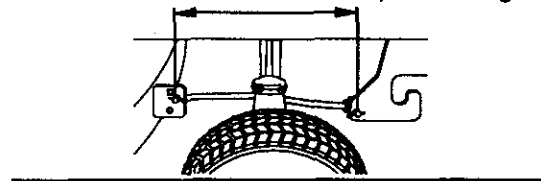

## TO REPLACE MOWER BLADE DRIVE BELT

The mower blade drive belt may be replaced without tools. Park the tractor on level surface. Engage parking brake.

### BELT REMOVAL -

- Remove mower from tractor (See "TO REMOVE MOWER" in this section of this manual).
- Work belt off both mandrel pulleys and idler pulleys.
- Pull belt away from mower.

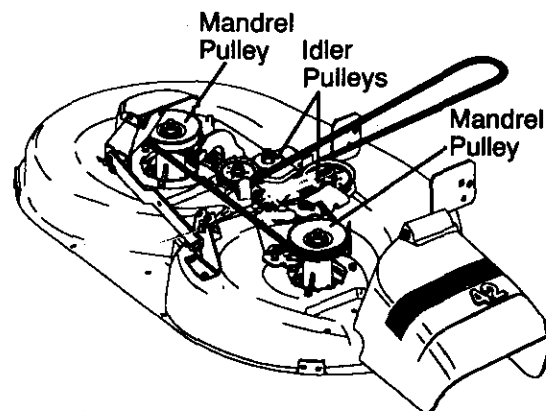

## BELT INSTALLATION -

- Install new belt in reverse order of removal.
- Make sure belt is in all pulley grooves and inside all belt guides.
- Install mower in reverse order of removal instructions.

## TO ADJUST BRAKE

Your tractor is equipped with an adjustable brake system which is mounted on the right side of the transaxle. If tractor requires more than six (6) feet stopping distance at high speed in highest gear, then brake must be adjusted.

- Depress clutch/brake pedal and engage parking brake.
- Measure distance between brake operating arm and nut "A" on brake rod.
- If distance is other than 1-1/2", loosen jam nut and turn nut "A" until distance becomes 1-1/2". Retighten jam nut against nut "A".
- Road test tractor for proper stopping distance as stated above. Readjust if necessary. If stopping distance is still greater than six (6) feet in highest gear, further maintenance is necessary. Contact your nearest authorized service center/department.

With Parking Brake "Engaged"

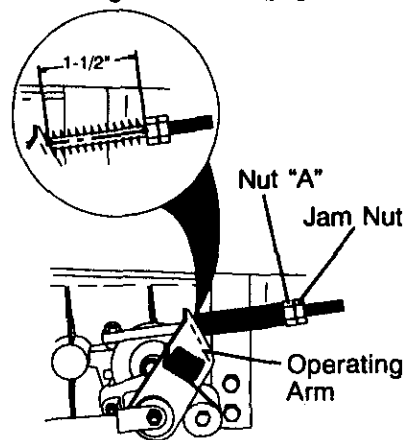

## TO REPLACE MOTION DRIVE BELT

Park the tractor on level surface. Engage parking brake. For assistance, there is a belt installation guide decal on bottom side of left footrest.

- Remove mower (See "TO REMOVE MOWER" in this section of this manual.)

- Remove belt from stationary idler and clutching idler.
- Pull belt slack toward rear of tractor. Remove belt upwards from transaxle pulley by deflecting belt keepers.
- Pull belt toward front of tractor and remove downwards from around engine pulley.
- Install new belt by reversing above procedure.

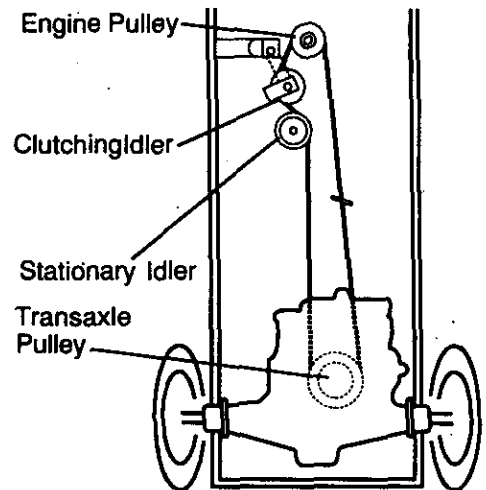

## TRANSAXLE GEAR SHIFT LEVER NEUTRAL ADJUSTMENT

The transaxle should be in neutral when the gear shift lever is in neutral (N) (lock gate) position. The adjustment is preset at the factory; however, if adjustment is needed, proceed as follows:

- Make sure transaxle is in neutral (N).
- NOTE:** When the tractor rear wheels move freely, the transaxle is in neutral.
- Loosen adjustment bolt in front of the right rear wheel.
- Position the gear shift lever in the neutral (N) position.
- Tighten adjustment bolt securely.

**NOTE:** If additional clearance is needed to get to adjustment bolt, move mower deck height to the lowest position.

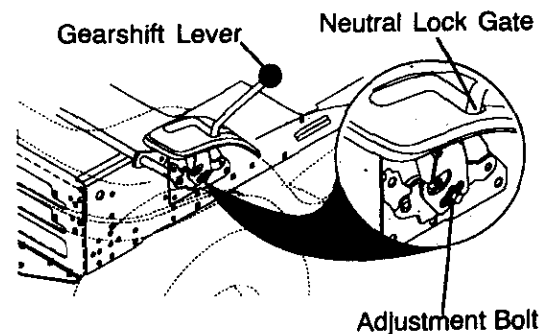

## TO ADJUST STEERING WHEEL ALIGNMENT

If steering wheel crossbars are not horizontal (left to right) when wheels are positioned straight forward, remove steering wheel and reassemble per instructions in the Assembly section of this manual.

## FRONT WHEEL TOE-IN/CAMBER

The front wheel toe-in and camber are not adjustable on your tractor. If damage has occurred to affect the front wheel toe-in or camber, contact your nearest authorized service center/department.

## TO REMOVE WHEEL FOR REPAIRS

- Block up axle securely.
- Remove axle cover, retaining ring and washers to allow wheel removal (rear wheel contains a square key - Do not lose).
- Repair tire and reassemble.
- On rear wheels only: align grooves in rear wheel hub and axle. Insert square key.
- Replace washers and snap retaining ring securely in axle groove.
- Replace axle cover.

**NOTE:** To seal tire punctures and prevent flat tires due to slow leaks, tire sealant may be purchased from your local parts dealer. Tire sealant also prevents tire dry rot and corrosion.

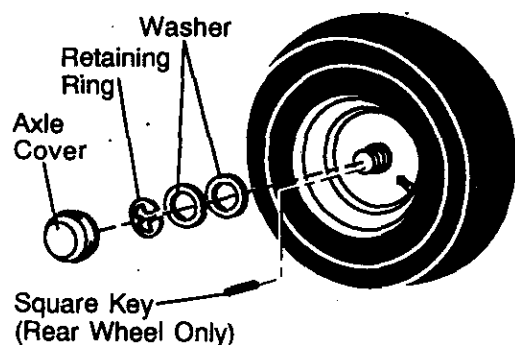

## TO START ENGINE WITH A WEAK BATTERY

**⚠ CAUTION:** Lead-acid batteries generate explosive gases. Keep sparks, flame and smoking materials away from batteries. Always wear eye protection when around batteries.

If your battery is too weak to start the engine, it should be recharged. (See "BATTERY" in the MAINTENANCE section of this manual).

If "jumper cables" are used for emergency starting, follow this procedure:

**IMPORTANT:** Your tractor is equipped with a 12 volt negative grounded system. The other vehicle must also be a 12 volt negative grounded system. Do not use your tractor battery to start other vehicles.

## TO ATTACH JUMPER CABLES -

- Connect each end of the RED cable to the POSITIVE (+) terminal of each battery, taking care not to short against chassis.
- Connect one end of the BLACK cable to the NEGATIVE (-) terminal of fully charged battery.
- Connect the other end of the BLACK cable to good CHASSIS GROUND, away from fuel tank and battery.

## TO REMOVE CABLES, REVERSE ORDER -

- BLACK cable first from chassis and then from the fully charged battery.
- RED cable last from both batteries.

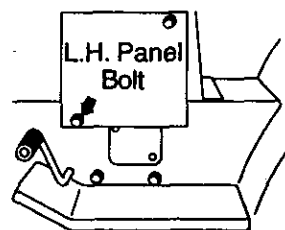
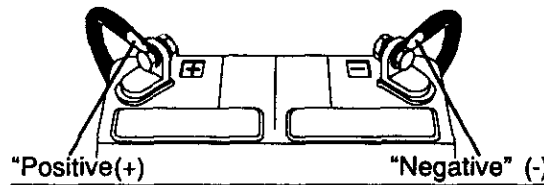

## REPLACING BATTERY

**⚠ CAUTION:** Do not short battery terminals by allowing a wrench or any other object to contact both terminals at the same time. Before connecting battery, remove metal bracelets, wristwatch bands, rings, etc.

- Lift hood to raised position.
- Remove terminal guard.
- Disconnect BLACK battery cable then RED battery cable and carefully remove battery from tractor.
- Install new battery with terminals in same position as old battery.
- Reinstall terminal guard.
- First connect RED battery cable to positive (+) battery terminal with hex bolt and keps nut as shown. Tighten securely.



- Connect BLACK grounding cable to negative (-) battery terminal with remaining hex bolt and keps nut. Tighten securely
- Close terminal access doors.
- Close hood.

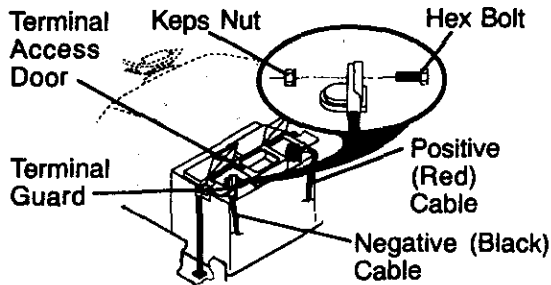

### TO REPLACE HEADLIGHT BULB

- Raise hood.
- Pull bulb holder out of the hole in the backside of the grill.
- Replace bulb in holder and push bulb holder securely back into the hole in the backside of the grill.
- Close hood.

### INTERLOCKS AND RELAYS

Loose or damaged wiring may cause your tractor to run poorly, stop running, or prevent it from starting.

- Check wiring. See electrical wiring diagram in the Repair Parts section.

### TO REPLACE FUSE

Replace with 15 amp automotive-type plug-in fuse. The fuse holder is located behind the dash.

### TO REMOVE HOOD AND GRILL ASSEMBLY

- Raise hood.
- Unsnap headlight wire connector.
- Stand in front of tractor. Grasp hood at sides, tilt toward engine and lift off of tractor.
- To replace, reverse above procedure.

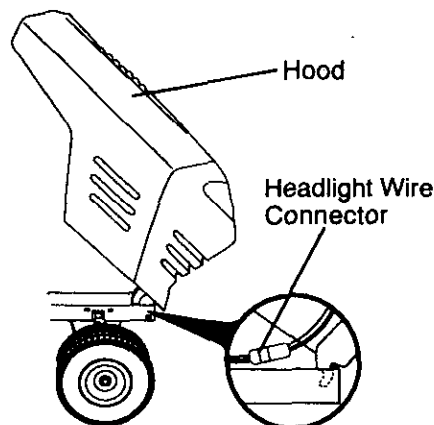

### ENGINE

Maintenance, repair, or replacement of the emission control devices and systems, which are being done at the customers expense, may be performed by any non-road engine repair establishment or individual. Warranty repairs must be performed by an authorized engine manufacturer's service outlet.

### TO ADJUST THROTTLE CONTROL CABLE

The throttle control has been preset at the factory and adjustment should not be necessary. Check adjustment as described below before loosening cable. If adjustment is necessary, proceed as follows:

- With engine not running, move throttle control lever to fast position.
- Check that swivel is against side of quarter circle. If it is not, loosen cable clamp screw and pull cable back until swivel is against quarter circle.

Tighten cable clamp screw securely.

### TO ADJUST CHOKE CONTROL

The choke control has been preset at the factory and adjustment should not be necessary. Check adjustment as described below before loosening cable. If adjustment is necessary, proceed as follows:

- With engine not running, move choke control (located on dash panel) to full choke position.
- Remove air cleaner cover, filter and cartridge plate to expose carburetor choke (see "AIR FILTER" in the Customer Responsibilities section of this manual).
- Choke should be closed. If it is not, loosen casing clamp screw and move choke cable until choke is completely closed. Tighten casing clamp screw securely.
- Reassemble air cleaner.

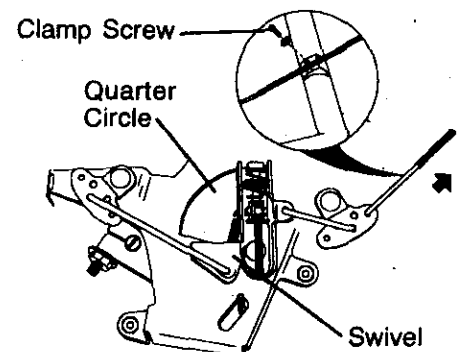

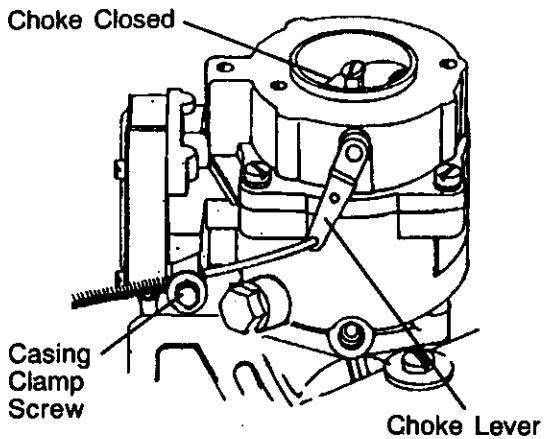

**TO ADJUST CARBURETOR**

The carburetor has been preset at the factory and adjustment should not be necessary. However, minor adjustment may be required to compensate for differences in fuel, temperature, altitude or load. If the carburetor does need adjustment, proceed as follows:

In general, turning the mixture screw **in** (clockwise) decreases the supply of fuel to the engine giving a leaner fuel/air mixture. Turning the mixture screw **out** (counterclockwise) increases the supply of fuel to the engine giving a richer fuel/air mixture.

**IMPORTANT:** Damage to the needles and the seats in carburetor may result if screw is turned in too tight.

**PRELIMINARY SETTING -**

- Be sure you have a clean air filter, and the throttle control cable and choke are adjusted properly (see above).
- With engine off turn idle mixture screw **in** (clockwise) closing it finger tight and then turn **out** (counterclockwise) 1-1/4 to 1-1/2 turns.

**FINAL SETTING -**

- Start engine and allow to warm for five minutes. Make final adjustments with engine running and shift/ motion control lever in neutral (N) position.
- With throttle control lever in slow position, hold throttle lever against idle speed screw and adjust idle speed screw to obtain 1200 to 1400 RPM.
- While still holding throttle lever against idle speed screw, turn idle mixture screw **in** (clockwise) until engine begins to die and then turn **out** (counterclockwise) until engine runs rough. Turn screw to a point midway between those two positions.

- Continue to hold throttle lever against idle speed screw and adjust idle speed screw to obtain 900 to 1200 RPM. Release throttle lever.

**ACCELERATION TEST -**

- Move throttle control lever from slow to fast position. If engine hesitates or dies, turn idle mixture screw **out** (counterclockwise) 1/8 turn. Repeat test and continue to adjust, if necessary, until engine accelerates smoothly.

High speed stop is factory adjusted. Do not adjust - damage may result.

**IMPORTANT:** Never tamper with the engine governor, which is factory set for proper engine speed. overspeeding the engine above the factory high speed setting can be dangerous. if you think the engine-governed high speed needs adjusting, contact your nearest authorized service center/department, which has proper equipment and experience to make any necessary adjustments.

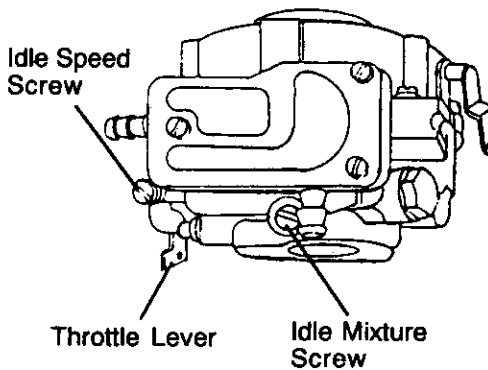
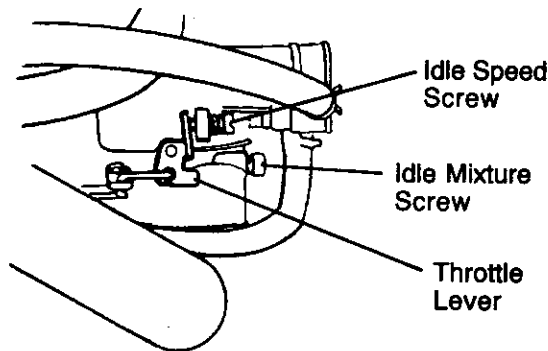

# STORAGE

Immediately prepare your tractor for storage at the end of the season or if the tractor will not be used for 30 days or more.

**⚠ CAUTION:** Never store the tractor with gasoline in the tank inside a building where fumes may reach an open flame or spark. Allow the engine to cool before storing in any enclosure.

## TRACTOR

Remove mower from tractor for winter storage. When mower is to be stored for a period of time, clean it thoroughly, remove all dirt, grease, leaves, etc. Store in a clean, dry area.

- Clean entire tractor (See "CLEANING" in the Maintenance section of this manual).
- Inspect and replace belts, if necessary (See belt replacement instructions in the Service and Adjustments section of this manual).
- Lubricate as shown in the Maintenance section of this manual.
- Be sure that all nuts, bolts and screws are securely fastened. Inspect moving parts for damage, breakage and wear. Replace if necessary.
- Touch up all rusted or chipped paint surfaces; sand lightly before painting.

## BATTERY

- Fully charge the battery for storage.
- After a period of time in storage, battery may require recharging.
- To help prevent corrosion and power leakage during long periods of storage, battery cables should be disconnected and battery cleaned thoroughly (see "TO CLEAN BATTERY AND TERMINALS" in the Maintenance section of this manual).
- After cleaning, leave cables disconnected and place cables where they cannot come in contact with battery terminals.
- If battery is removed from tractor for storage, do not store battery directly on concrete or damp surfaces.

## ENGINE

### FUEL SYSTEM

**IMPORTANT:** It is important to prevent gum deposits from forming in essential fuel system parts such as carburetor, fuel filter, fuel hose, or tank during storage.

Also, experience indicates that alcohol blended fuels (called gasohol or using ethanol or methanol) can attract moisture which leads to separation and formation of acids during storage. Acidic gas can damage the fuel system of an engine while in storage.

- Drain the fuel tank.
- Start the engine and let it run until the fuel lines and carburetor are empty.
- Never use engine or carburetor cleaner products in the fuel tank or permanent damage may occur.
- Use fresh fuel next season.

**NOTE:** Fuel stabilizer is an acceptable alternative in minimizing the formation of fuel gum deposits during storage. Add stabilizer to gasoline in fuel tank or storage container. Always follow the mix ratio found on stabilizer container. Run engine at least 10 minutes after adding stabilizer to allow the stabilizer to reach the carburetor. Do not drain the gas tank and carburetor if using fuel stabilizer.

### ENGINE OIL

Drain oil (with engine warm) and replace with clean engine oil. (See "ENGINE" in the Maintenance section of this manual).

### CYLINDER(S)

- Remove spark plug(s).
- Pour one ounce of oil through spark plug hole(s) into cylinder(s).
- Turn ignition key to "START" position for a few seconds to distribute oil.
- Replace with new spark plug(s).

### OTHER

- Do not store gasoline from one season to another.
- Replace your gasoline can if your can starts to rust. Rust and/or dirt in your gasoline will cause problems.
- If possible, store your tractor indoors and cover it to give protection from dust and dirt.
- Cover your tractor with a suitable protective cover that does not retain moisture. Do not use plastic. Plastic cannot breathe which allows condensation to form and will cause your tractor to rust.

**IMPORTANT:** Never cover tractor while engine and exhaust areas are still warm.

## TROUBLESHOOTING CHART

PROBLEM	CAUSE	CORRECTION
<b>Will not start</b>	<ul style="list-style-type: none"> <li>• Out of fuel.</li> <li>• Engine not "CHOKED" properly.</li> <li>• Engine flooded.</li>   <li>• Bad spark plug.</li> <li>• Dirty air filter.</li> <li>• Dirty fuel filter.</li> <li>• Water in fuel.</li>   <li>• Loose or damaged wiring.</li> <li>• Carburetor out of adjustment.</li>   <li>• Engine valves out of adjustment.</li> </ul>	<ul style="list-style-type: none"> <li>• Fill fuel tank.</li> <li>• See "TO START ENGINE" in Operation section.</li> <li>• Wait several minutes before attempting to start.</li> <li>• Replace spark plug.</li> <li>• Clean/replace air filter.</li> <li>• Replace fuel filter.</li> <li>• Drain fuel tank and carburetor, refill tank with fresh gasoline and replace fuel filter.</li> <li>• Check all wiring.</li>   <li>• See "To Adjust Carburetor" in Service Adjustments section.</li> <li>• Contact an authorized service center/department.</li> </ul>
<b>Hard to start</b>	<ul style="list-style-type: none"> <li>• Dirty air filter.</li> <li>• Bad spark plug.</li> <li>• Weak or dead battery.</li>   <li>• Dirty fuel filter.</li> <li>• Stale or dirty fuel.</li>   <li>• Loose or damaged wiring.</li> <li>• Carburetor out of adjustment.</li>   <li>• Engine valves out of adjustment.</li> </ul>	<ul style="list-style-type: none"> <li>• Clean/replace air filter.</li> <li>• Replace spark plug.</li> <li>• Recharge or replace battery.</li> <li>• Replace fuel filter.</li> <li>• Drain fuel tank and refill with fresh gasoline.</li> <li>• Check all wiring.</li>   <li>• See "To Adjust Carburetor" in Service Adjustments section.</li> <li>• Contact an authorized service center/department.</li> </ul>
<b>Engine will not turn over</b>	<ul style="list-style-type: none"> <li>• Clutch/brake pedal not depressed.</li> <li>• Attachment clutch is engaged.</li> <li>• Weak or dead battery.</li>   <li>• Blown fuse.</li> <li>• Corroded battery terminals.</li> <li>• Loose or damaged wiring.</li> <li>• Faulty ignition switch.</li>   <li>• Faulty solenoid or starter.</li> <li>• Faulty operator presence switch(es).</li> </ul>	<ul style="list-style-type: none"> <li>• Depress clutch/brake pedal.</li> <li>• Disengage attachment clutch.</li> <li>• Recharge or replace battery.</li> <li>• Replace fuse.</li> <li>• Clean battery terminals.</li>   <li>• Check all wiring.</li>   <li>• Check/replace ignition switch.</li> <li>• Check/replace solenoid or starter.</li> <li>• Contact an authorized service center/department.</li> </ul>
<b>Engine clicks but will not start</b>	<ul style="list-style-type: none"> <li>• Weak or dead battery.</li>   <li>• Corroded battery terminals.</li> </ul>	<ul style="list-style-type: none"> <li>• Recharge or replace battery.</li> <li>• Clean battery terminals.</li> </ul>

## TROUBLESHOOTING CHART

PROBLEM	CAUSE	CORRECTION
<b>Engine clicks but will not start (Cont'd)</b>	<ul style="list-style-type: none"> <li>• Loose or damaged wiring.</li> <li>• Faulty solenoid or starter.</li> </ul>	<ul style="list-style-type: none"> <li>• Check all wiring.</li> <li>• Check/replace solenoid or starter.</li> </ul>
<b>Loss of power</b>	<ul style="list-style-type: none"> <li>• Cutting too much grass/too fast.</li> <li>• Throttle in "CHOKE" position.</li> <li>• Build-up of grass, leaves and trash under mower.</li> <li>• Dirty air filter.</li> <li>• Low oil level/dirty oil.</li> <li>• Faulty spark plug.</li>   <li>• Dirty fuel filter.</li> <li>• Stale or dirty fuel.</li>   <li>• Water in fuel.</li>   <li>• Spark plug wire loose.</li> <li>• Dirty engine air screen/fins.</li> <li>• Dirty/clogged muffler.</li> <li>• Loose or damaged wiring.</li> <li>• Carburetor out of adjustment.</li> <li>• Engine valves out of adjustment.</li> </ul>	<ul style="list-style-type: none"> <li>• Set in "Higher Cut" position/ reduce speed.</li> <li>• Adjust throttle control.</li>   <li>• Clean underside of mower housing.</li>   <li>• Clean/replace air filter.</li> <li>• Check oil level/change oil.</li> <li>• Clean and regap or change spark plug.</li> <li>• Replace fuel filter.</li> <li>• Drain fuel tank and refill with fresh gasoline.</li> <li>• Drain fuel tank and carburetor, refill tank with fresh gasoline and replace fuel filter.</li> <li>• Connect and tighten spark plug wire.</li> <li>• Clean engine air screen/fins.</li>   <li>• Clean/replace muffler.</li> <li>• Check all wiring.</li>   <li>• See "To Adjust Carburetor" in Service Adjustments section.</li> <li>• Contact an authorized service center/department.</li> </ul>
<b>Excessive vibration</b>	<ul style="list-style-type: none"> <li>• Worn, bent or loose blade.</li> <li>• Bent blade mandrel.</li> <li>• Loose/damaged part(s).</li> </ul>	<ul style="list-style-type: none"> <li>• Replace blade. Tighten blade bolt.</li> <li>• Replace blade mandrel.</li> <li>• Tighten loose part(s). Replace damaged parts.</li> </ul>
<b>Engine continues to run when operator leaves seat with attachment clutch engaged</b>	<ul style="list-style-type: none"> <li>• Faulty operator-safety presence control system.</li> </ul>	<ul style="list-style-type: none"> <li>• Check wiring, switches and connections. If not corrected, contact an authorized service center/department.</li> </ul>
<b>Poor cut - uneven</b>	<ul style="list-style-type: none"> <li>• Worn, bent or loose blade.</li> <li>• Mower deck not level.</li> <li>• Buildup of grass, leaves, and trash under mower.</li> <li>• Bent blade mandrel.</li> <li>• Clogged mower deck vent holes from buildup of grass, leaves, and trash around mandrels.</li> </ul>	<ul style="list-style-type: none"> <li>• Replace blade. Tighten blade bolt.</li> <li>• Level mower deck.</li> <li>• Clean underside of mower housing.</li>   <li>• Replace blade mandrel.</li> <li>• Clean around mandrels to open vent holes.</li> </ul>

## TROUBLESHOOTING CHART

PROBLEM	CAUSE	CORRECTION
<b>Mower blades will not rotate</b>	<ul style="list-style-type: none"> <li>• Obstruction in clutch mechanism.</li> <li>• Worn/damaged mower drive belt.</li> <li>• Frozen idler pulley.</li> <li>• Frozen blade mandrel.</li> </ul>	<ul style="list-style-type: none"> <li>• Remove obstruction.</li> <li>• Replace mower drive belt.</li> <li>• Replace idler pulley.</li> <li>• Replace blade mandrel.</li> </ul>
<b>Poor grass discharge</b>	<ul style="list-style-type: none"> <li>• Engine speed too slow.</li> <li>• Travel speed too fast.</li> <li>• Wet grass.</li> <li>• Mower deck not level.</li> <li>• Low/uneven tire air pressure.</li> <li>• Worn, bent or loose blade.</li> <li>• Buildup of grass, leaves and trash under mower.</li> <li>• Mower drive belt worn.</li> <li>• Blades improperly installed.</li> <li>• Improper blades used.</li> <li>• Clogged mower deck vent holes from buildup of grass, leaves, and trash around mandrels.</li> </ul>	<ul style="list-style-type: none"> <li>• Place throttle control in "FAST" position.</li> <li>• Shift to slower speed.</li> <li>• Allow grass to dry before mowing.</li> <li>• Level mower deck.</li> <li>• Check tires for proper air pressure.</li> <li>• Replace/sharpen blade. Tighten blade bolt.</li> <li>• Clean underside of mower housing.</li> <li>• Replace mower drive belt.</li> <li>• Reinstall blades sharp edge down.</li> <li>• Replace with blades listed in this manual.</li> <li>• Clean around mandrels to open vent holes.</li> </ul>
<b>Headlight(s) not working (if so equipped)</b>	<ul style="list-style-type: none"> <li>• Switch is "OFF".</li> <li>• Bulb(s) burned out.</li> <li>• Faulty light switch.</li> <li>• Loose or damaged wiring.</li> <li>• Blown fuse.</li> </ul>	<ul style="list-style-type: none"> <li>• Turn switch "ON".</li> <li>• Replace bulb(s).</li> <li>• Check/replace light switch.</li> <li>• Check wiring and connections.</li> <li>• Replace fuse.</li> </ul>
<b>Battery will not charge</b>	<ul style="list-style-type: none"> <li>• Bad battery cell(s).</li> <li>• Poor cable connections.</li> <li>• Faulty regulator (if so equipped).</li> <li>• Faulty alternator.</li> </ul>	<ul style="list-style-type: none"> <li>• Replace battery.</li> <li>• Check/clean all connections.</li> <li>• Replace regulator.</li> <li>• Replace alternator.</li> </ul>
<b>Engine "backfires" when turning engine "OFF"</b>	<ul style="list-style-type: none"> <li>• Engine throttle control not set at "SLOW" position for 30 seconds before stopping engine.</li> </ul>	<ul style="list-style-type: none"> <li>• Move throttle control to "SLOW" position and allow to idle for 30 seconds before stopping engine.</li> </ul>

# TRACTOR -- MODEL NUMBER 917.270850

## SCHEMATIC

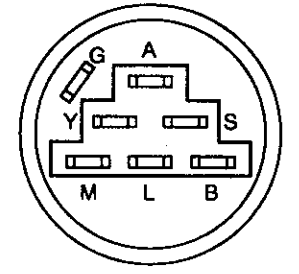
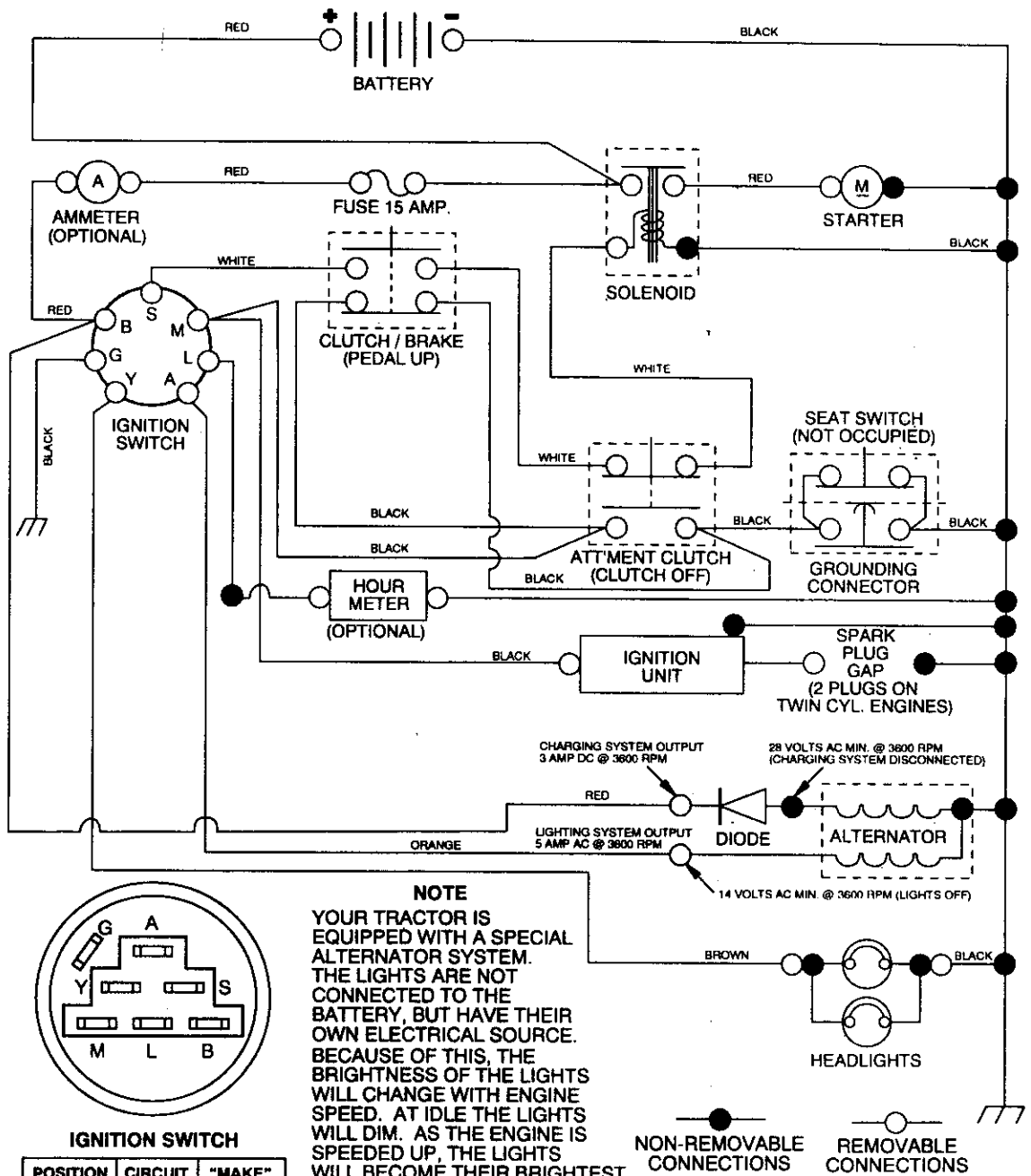

**IGNITION SWITCH**

POSITION	CIRCUIT	"MAKE"
OFF	G + M + L	NONE
RUN/LIGHT	B + L	A + Y
RUN	B + L	NONE
START	B + L + S	NONE

# REPAIR PARTS

TRACTOR--MODEL NUMBER 917.270850

## ELECTRICAL

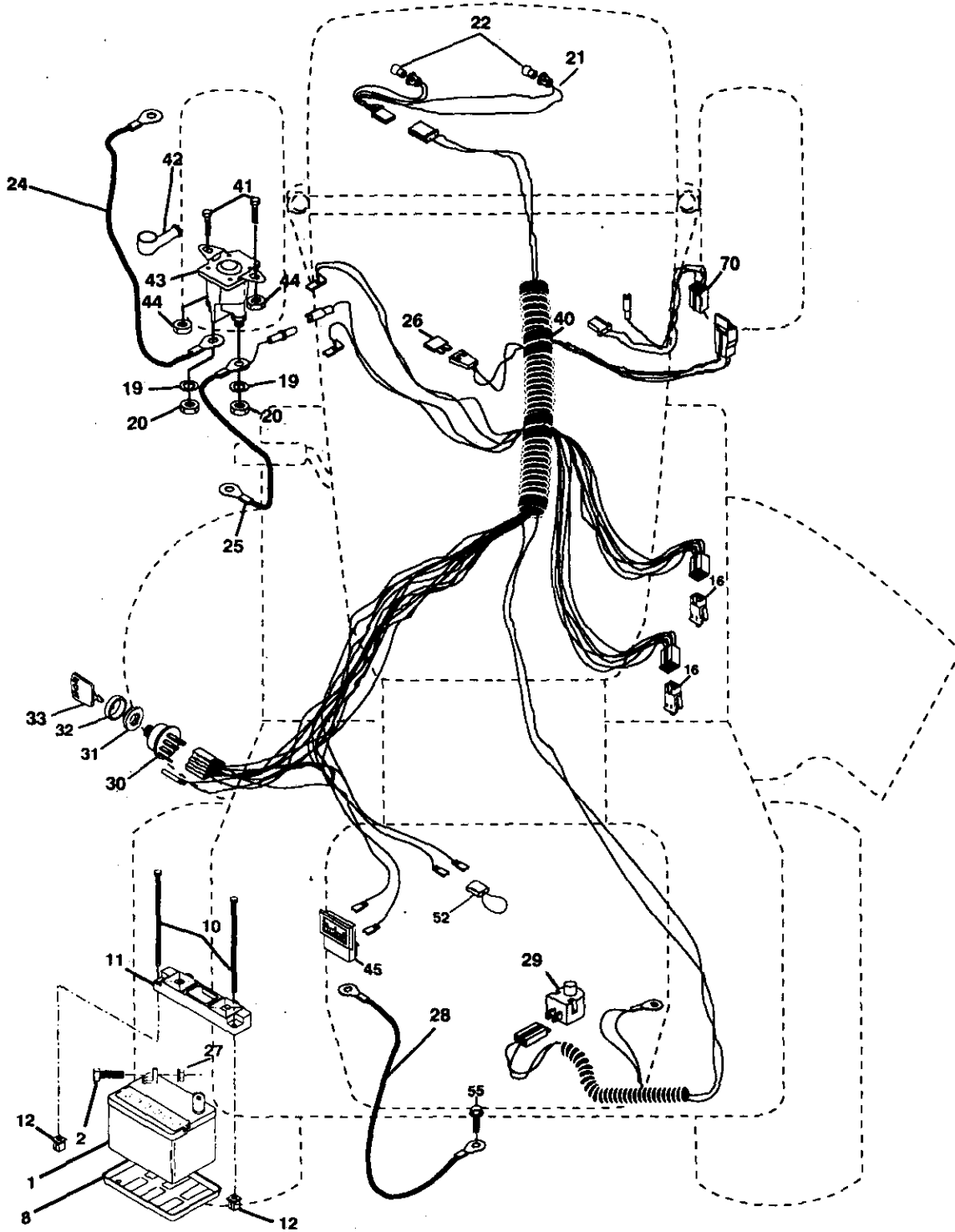



# TRACTOR--MODEL NUMBER 917.270850

## ELECTRICAL

KEY PART NO.	NO.	DESCRIPTION
1	163465	Battery 12 VOLT 28 AMP
2	74760412	Bolt Hex Hd 1/4-20unc x 3/4
8	7603J	Case Battery
10	145211	Bolt, Btr Front 1/4-20 x 7-1/2
11	150109	Holddown Battery Front Mount
12	145769	Nut, Push Nylon Battery Front 1/4
16	153664	Switch, Interlock Push-In
19	Std551125	Washer Lock 1/4
20	73350400	Nut Jam Hex 1/4-20 Unc
21	166182	Harness Light Socket (W/4152j)
22	4152J	Bulb Light #1156
24	4799J	Cable Battery
25	146148	Cable Battery
26	166180	Fuse
27	73510400	Nut Keps Hex 1/4-20 Unc
28	145491	Cable Ground
29	121305X	Switch Seat
30	140301	Switch Ign 4 Position
31	124211X	Nut Ignition
32	141226	Cover Ignition Switch
33	109310X	Key Molded Craftsman
40	169596	Harness Ign
41	71110408	Bolt Blk. Fin Hex 1/4-20 Unc x 1/2
42	131563	Cover Terminal
43	168327	Solenoid
44	73640400	Nut Keps Blk Hex 1/4-20 Unc
45	121433X	Ammeter Rectangular 6 Amp
52	141940	Protection Wire Loop
55	17490508	Screw Thdrol 5/16-18 x 1/2
70	166658	Harness Engine B&S

**NOTE:** All component dimensions given in U. S.  
inches 1 inch = 25/4 mm

# TRACTOR--MODEL NUMBER 917.270850

## CHASSIS AND ENCLOSURES

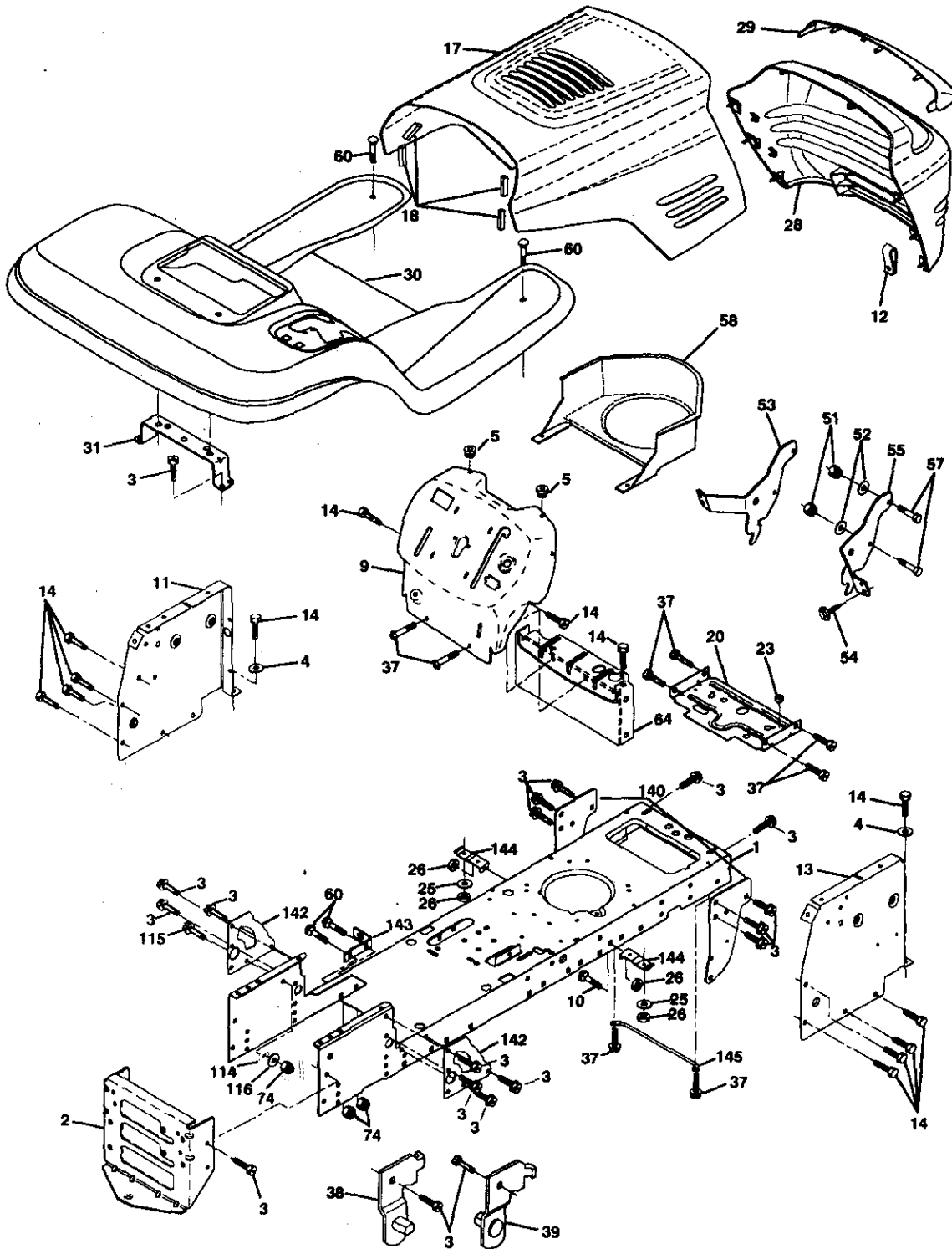

**TRACTOR--MODEL NUMBER 917.270850**  
**CHASSIS AND ENCLOSURES**

KEY PART NO.	PART NO.	DESCRIPTION
1	166819	Chassis Assembly
2	140356	Drawbar
3	17060612	Screw 3/8-16 x 3/4
4	STD551025	Washer 13/32 x 3/4 x 16 Gauge
5	155272	Bumper Hood/Dash
9	165454X013	Dash
10	STD533710	Bolt, Carriage 3/8-16 x 1
11	155927	Panel, Dash, L.H.
12	145660	Clip Tinnerman Grille P/L
13	169118	Panel, Dash, R.H.
14	17490608	Screw Thdrol 3/8-16 x 1/2
17	144983X558	Hood Assembly
18	126938X	Bumper Hood
20	156437	Plate Mtg Battery Fuel Tank
23	124028X	Bushing, Snap, Nylon, Fuel Line
25	19131312	Washer 13/32 x 13/16 x 12 Gauge
26	STD541437	Locknut, Hex, with Insert 3/8-16 Unc
28	156725X558	Grille w/Clips MS-558
29	155217X599	Lens, Grille
30	151287X558	Fend/Ftrest
31	139976	Bracket, Fender Support
37	17490508	Screw Thdrol 5/16-18 x 1/2
38	139886	Pivot Bracket Assembly, L.H.
39	139887	Pivot Bracket Assembly, R.H.
51	73800400	Nut Lock w/Insert 1/4-20 UNC
52	19091416	Washer 9/32 x 7/8 x 16 Ga.
53	145201	Bracket Grille Pickoff LH
54	161464	Screw Hex Wshd 8-18 x 7/8
55	145202	Bracket Grille Pickoff RH
57	STD522507	Bolt, Fin Hex 1/4-20 UNC x .75
58	140547	Air Duct P/L 18HP B&S Opp. Twin
60	STD533707	Bolt Rdhd Sqnk 3/8-16 UNC x 3/4
64	154798	Dash Lower STLT
74	STD541437	Nut Crownlock 3/8-16 UNC
114	158112	Keeper Belt Rear Lh Stl
115	17060620	Screw 3/8-16 x 1-1/4
116	19131614	Washer 13/32 x 1 x 14 Ga.
140	158418	Bracket Suspension Front
142	165867	Plate Reinforcement STLT
143	154966	Bracket Swaybar Chassis
144	154207	Bracket Pnt Footrest STLT
145	156524	Rod Pivot Chassis/Hood

**NOTE:** All component dimensions given in U. S.  
inches 1 inch = 25/4 mm

# TRACTOR -- MODEL NUMBER 917.270850

## GROUND DRIVE

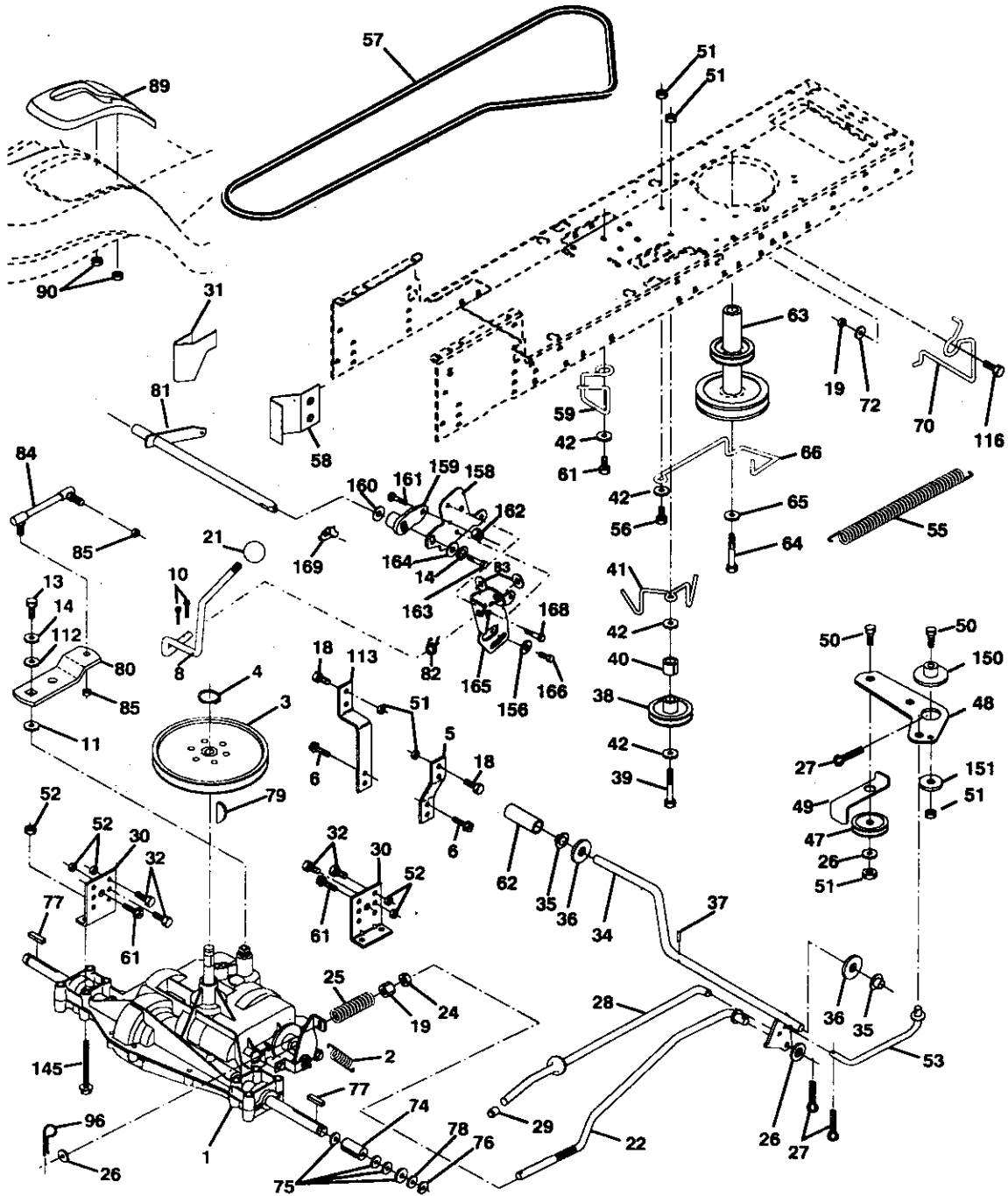

# TRACTOR -- MODEL NUMBER 917.270850

## GROUND DRIVE

KEY NO.	PART NO.	DESCRIPTION	KEY NO.	PART NO.	DESCRIPTION
1	-----	Transaxle (See Breakdown) Peerless 206-545C	59	140312	Keeper, Belt, Center Span
2	146682	Spring, Return, Brake	61	17060612	Screw 3/8-16 x 3/4
3	123666X	Pulley, Transaxle	62	8883R	Cover, Pedal
4	1200028	Ring, Retainer	63	140186	Pulley, Engine
5	121520X	Strap, Torque	64	164975	Bolt, Hex 7/16-20 x 4 Grade 5
6	17060512	Screw 5/16-18 x 3/4	65	STD551143	Washer
8	165866	Rod Shifter Fender STLT	66	154778	Keeper, Belt, Engine, Fool-Proof
10	STD561210	Pin, Cotter	70	134683	Guide, Mower Drive Belt, R.H.
11	105701X	Washer, Shift Plate	72	19132012	Washer 13/32 x 1-1/4 x 12 Ga.
13	74550412	Bolt 1/4-28 UNF W/Patch Gr. 8	74	137057	Spacer, Axle
14	10040400	Washer Lock Hvy Helical	75	121749X	Washer 25/32 x 1-1/4 x 16 Ga.
18	STD523710	Bolt Fin Hex 3/8-16UNC x 1 Gr 5	76	STD581075	E-Ring
19	STD541437	Nut	77	123583X	Key, Square 2.0 x .1845/.1865
21	106933X	Knob	78	121748X	Washer 25/32 x 1-5/8 x 16 Ga
22	130804	Rod, Brake	79	STD580025	Key Woodruff
24	STD541237	Nut	80	145090	Arm, Shift
25	106888X	Spring, Brake Rod	81	165592	Shaft Asm Cross Tapered 650 20
26	STD551037	Washer	82	165711	Spring, Torsion
27	STD561210	Pin	83	19171216	Washer 17/32 x 3/4 x 16 Ga.
28	145204	Rod, Parking Brake	84	166231	Link Transaxle
29	124236X	Cap, Parking Brake, Red	85	150360	Nut, Nylock
30	130807	Bracket, Transaxle	89	158391X428	Console, Shift, STLT
31	127275X	Keeper, Belt, L.H.	90	124346X	Nut, Self-Thdng, Wsh Hd 1/4
32	STD523107	Bolt	96	STD624003	Retainer Spring 1"
34	155071	Shaft Assembly, Foot Pedal	112	19091210	Washer 9/32 x 3/4 x 10 Gauge
35	120183X	Bearing, Nylon	113	127285X	Strap Torque 90 Degrees
36	STD551062	Washer	116	72110610	Bolt Rdhd Sqneck 3/8-16 x 1.25
37	STD571810	Roll Pin	145	74490540	Bolt, Hex Flghd 5/16-18 Gr. 5
38	131494	Pulley, Idler, Flat	150	165850	Bushing Bellcrank Grd. Drive
39	STD523727	Bolt	151	19133210	Washer 13/32 x 2 x 10 Ga.
40	4470J	Spacer, Split .395 x .59	156	166002	Washer Srrted 5/16ID x 1.125
41	165838	Keeper, Belt, Idler	158	165589	Bracket Shift Mount
42	19131312	Washer 13/32 x 13/16 x 12 Ga.	159	165494	Hub Tapered Flange Shift Lt
47	127783	Pulley, Idler, V-Groove, Plastic	160	19292016	Washer 29/32 x 1-1/4 x 16 Ga
48	154407	Bellcrank Clutch Grnd Drv Stil	161	72140406	Bolt Rdhd Sqnk 1/4-20 x 3/4 Gr.5
49	123205X	Retainer, Belt	162	73680400	Nut Crownlock 1/4-20 Unc
50	STD523715	Bolt	163	74780416	Bolt Hex Fin 1/4-20Unc x 1 Gr 5
51	STD541437	Nut Crown Lock 3/8-16 UNC	164	19091010	Washer 5/8 x .281 x 10 Ga
52	STD541431	Nut Crown Lock 5/16-18 UNC	165	165623	Bracket Pivot Lever
53	105710X	Link, Clutch	166	166880	Screw 5/16-18 x 5/8
55	105709X	Spring, Clutch Return	168	165492	Bolt Shoulder 5/16-18 x .561
56	STD523712	Bolt Fin Hex 3/8-16 x 1-1/4	169	165580	Plate Fastening Lt
57	130801	V-Belt, Ground Drive			
58	127274X	Keeper, Belt, R.H.			

**NOTE:** All component dimensions given in U. S. inches 1 inch = 25/4 mm

# TRACTOR--MODEL NUMBER 917.270850

## STEERING

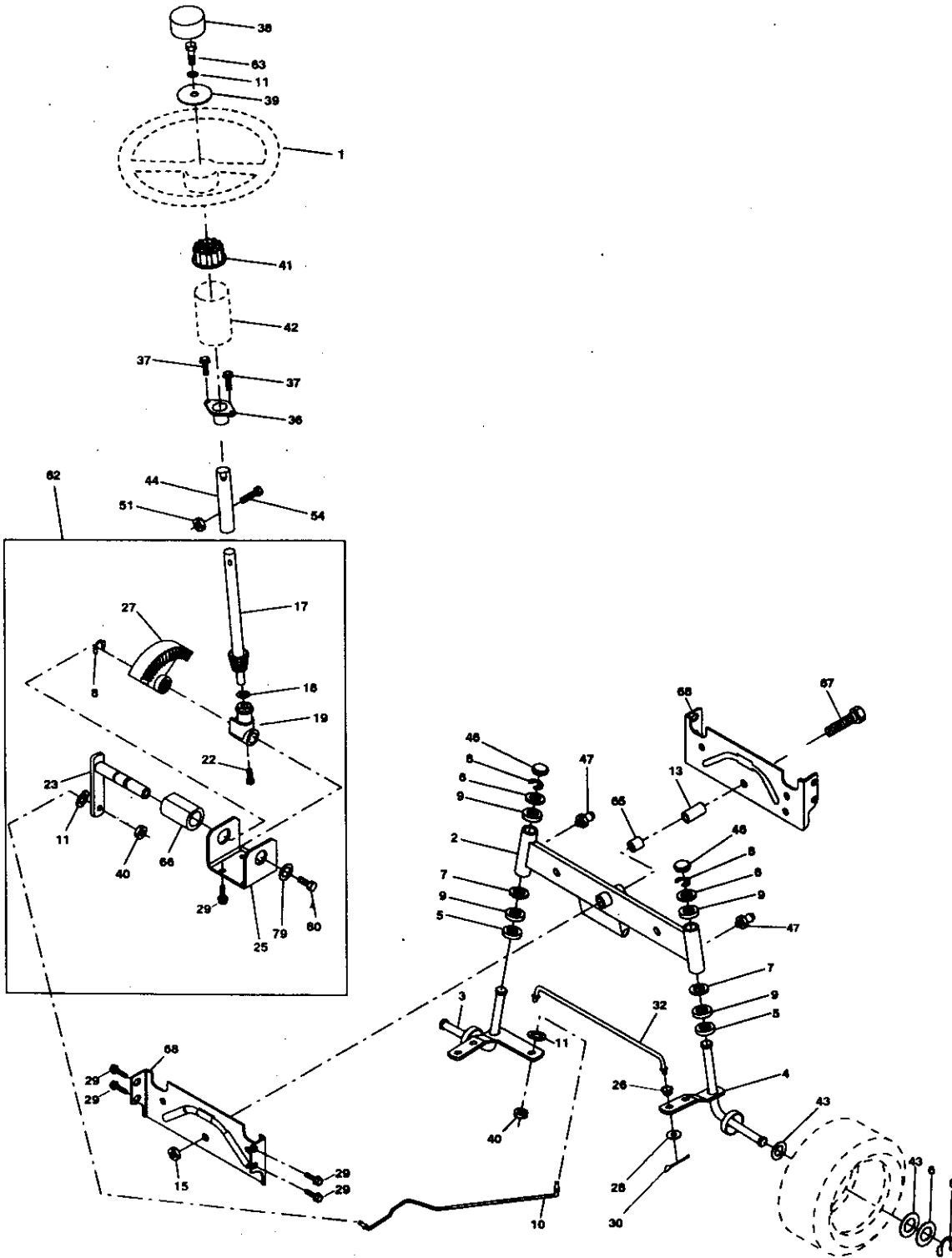

# TRACTOR--MODEL NUMBER 917.270850

## STEERING

KEY NO.	PART NO.	DESCRIPTION
1	139768	Steering Wheel
2	154427	Axle Assembly STMP Dropped STL
3	156483	Spindle Assembly, L.H.
4	157473	Spindle Assembly, R.H.
5	6266H	Bearing, Race, Thrust, Hardened
6	121748X	Washer 25/32 x 1-5/8 x 16 Gauge
7	19272016	Washer 27/32 x 1-1/4 x 16 Gauge
8	12000029	Ring, Klip
9	3366R	Bearing, Steering Column
10	156438	Draglink Extended Stamped
11	STD551137	Washer, Lock
13	154779	Bearing Axle STLT/GT
15	73901000	Nut, Lock, Flange 5/8-11 UNC
17	156546	Shaft Assembly, Steering
18	57079	Washer, Thrust .515 x .750 x .033
19	160395	Support, Shaft
22	165857	Screw Hex Wshhd Torx
23	165851	Pittman Shaft Assembly
25	154406	Bracket, Steering
26	126847X	Bushing, Link, Drag
27	136874	Gear, Sector
28	19131416	Washer 13/32 x 7/8 x 16 Gauge
29	17060612	Screw 3/8-16 x 3/4
30	STD561210	Pin
32	130465	Rod, Tie
36	155099	Bushing, Steering
37	152927	Screw
38	139769	Insert, Steering Wheel
39	19133812	Washer 13/32 x 2-3/8 x 12 Gauge
40	STD541537	Gripco Nut
41	100711L	Adaptor, Steering Wheel
42	145054X428	Boot, Steering Shaft
43	121749X	Washer 25/32 x 1-1/4 x 16 Gauge
44	153720	Extension Shaft Steering L.R.L.T
46	121232X	Cap, Spindle
47	6855M	Fitting, Grease
51	STD541431	Nut Lock Hex w/Ins. 5/16-18 UNC
54	74780520	Bolt Fin Hex 5/16-18 UNC x 1-1/4
62	167902	Kit Steering Asm Service
63	STD523710	Bolt, Fin Hex 3/8-16 UNC x 1 Gr 5
65	154780	Spacer Axle
66	154404	Bearing Arm Pittman
67	74781044	Bolt, Fin Hex 5/8-11 UNC x 2-3/4
68	154429	Axle, Brace
79	19132012	Washer 13/32 x 1-1/4 x 12 Ga
80	74950612	Bolt Hex Nylon 3/8-16 x 3/4

NOTE: All component dimensions given in U. S.  
inches 1 inch = 25/4 mm

# TRACTOR--MODEL NUMBER 917.270850

## ENGINE

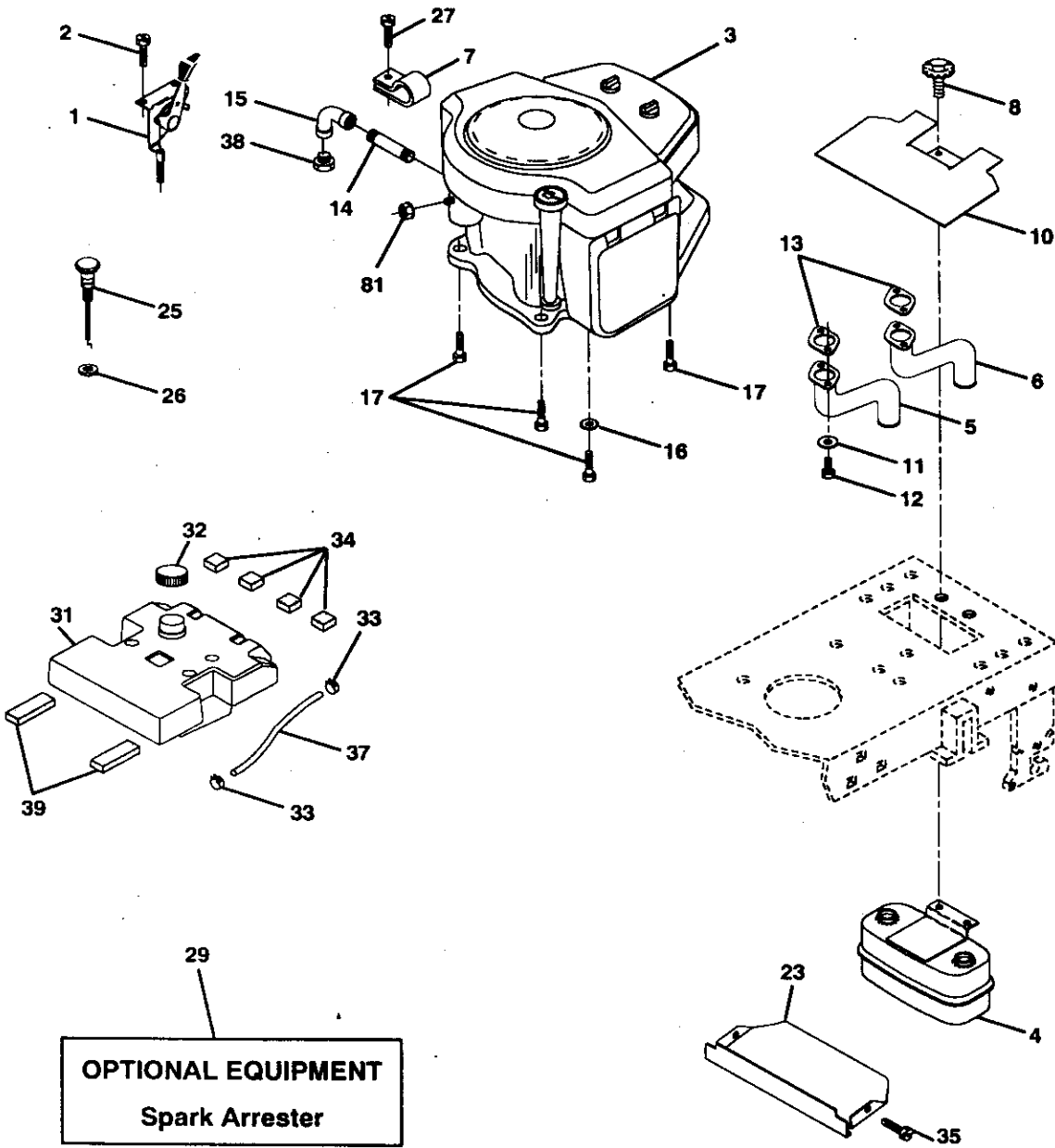



# TRACTOR--MODEL NUMBER 917.270850

## ENGINE

KEY NO.	PART NO.	DESCRIPTION
1	162152	Control, Throt Paddle 32 22
2	17720410	Screw, Hex Thd Cut 1/4-20 x 5/8
3	-----	Engine, B&S, (See Breakdown) No. 461707-0145-E1
4	149723	Muffler Exhaust
5	144069	Exhaust Asm. Left
6	144068	Exhaust Asm. Right
7	138129	Clamp Tube Double Engine
8	150176	Bolt 5/16-18unc x 3/4 W/Sems
10	145552	Heat Shield Lt
11	STD551125	Washer Lock Hvy. Helical 1/4
12	STD522507	Bolt Fin Hex 1/4-20Unc x .75
13	165287	Gasket, Muffler
14	13280336	Nipple, Pipe 4-1/2
15	13200300	Elbow, Standard 90°, 3/8-18 NPT
16	STD551237	Washer Lock Ext Tooth 3/8
17	17490624	Screw Thdrol 3/8-16x1-1/2 Tytt
23	159880	Shield, Brn/Dbr Guard
25	145996	Control Choke
26	73920600	Nut Keps 3/8-24 Unf
27	152927	Screw TT #10-32 x 5 x 3/8 Flange
29	137180	Arrestor, Spark
31	157103	Tank, Fuel
32	161696	Cap Fuel Guage
33	123487X	Clamp, Hose
34	106082X	Spacer Pad
35	17060512	Screw 5/16-18 x 3/4
37	8543R	Line, Fuel
38	-----	Plug, Oil Drain (See Engine Breakdown)
39	109227X	Pad Idler
81	128861	Nut Flange 1/4-20 Starter Nut

NOTE: All component dimensions given in U. S.  
inches 1 inch = 25/4 mm

# TRACTOR--MODEL NUMBER 917.270850

## SEAT ASSEMBLY

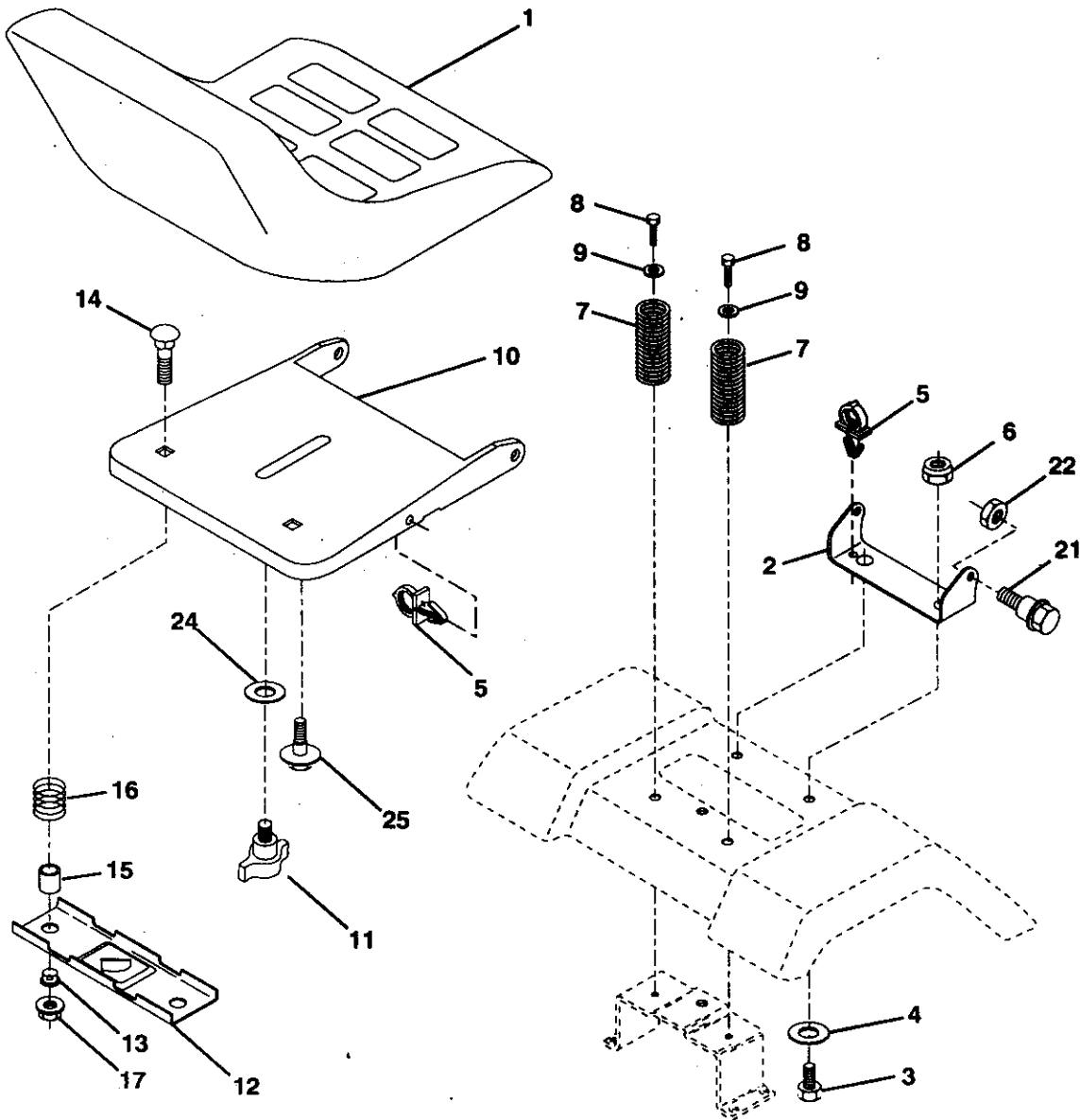

### KEY PART NO. NO.

KEY PART NO.	NO.	DESCRIPTION
1	140123	Seat 3350 Blk/blk Craftsman
2	140551	Bracket Pnt Pivot Seat (blk )
3	STD523710	Bolt Fin Hex 3/8-16unc X 1
4	19131610	Washer 13/32 X 3/4 X 10 Ga
5	145006	Clip Push In Hinged
6	STD541437	Nut Hex Lock w/Ins 3/8-16 Unc
7	124181X	Spring Seat Cprsn 2 250 Blk Zi
8	17060616	Screw 3/8-16 X 1-1/2
9	19131614	Washer 13/32 X 1 X 14 Ga
10	155925	Pan Pnt Seat (blk )
11	166369	Knob Seat
12	121246X	Bracket Pnt Mounting Switch

### KEY PART NO. NO.

KEY PART NO.	NO.	DESCRIPTION
13	121248X	Bushing Snap Blk Nyl 50 Id
14	72050412	Bolt Rdhd Sht Nk 1/4-20x1-1/2
15	134300	Spacer Split 28 X 96 Zinc
16	121250X	Spring Cprsn 1 27 Blk Pnt
17	123976X	Nut Lock 1/4 Lge Flg Gr 5 Zinc
21	153236	Bolt Shoulder 5/16-18 Unc-2A
22	STD541431	Nut Hex Lock w/Ins 5/16-18
24	19171912	Washer 17/32 X 1-3/16 X 12 Ga.
25	127018X	Bolt Shoulder 5/16-18 X 62

**NOTE:** All component dimensions given in U. S. inches 1 inch = 25/4 mm

## TRACTOR -- MODEL NUMBER 917.270850

### DECALS

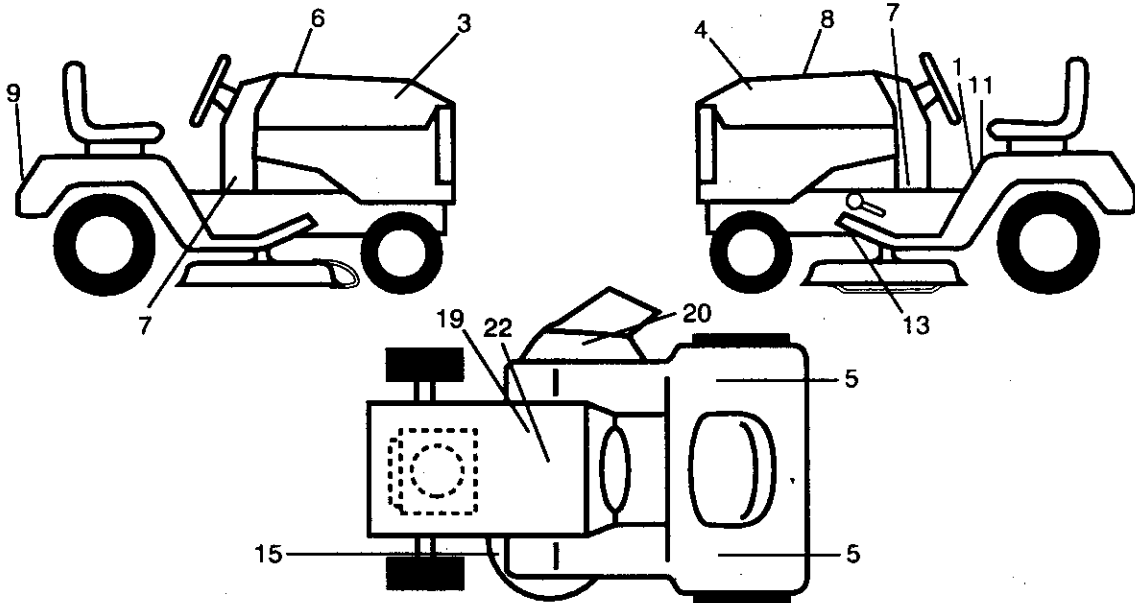

#### KEY PART NO. NO.

KEY PART NO. NO.	DESCRIPTION
1 156439	Decal, Fender Danger Sears
3 163200	Decal, Hood, R.H. Craftsman
4 163202	Decal, Hood, L.H. Craftsman
5 163207	Decal, Fender
6 133644	Decal, Maintenance
7 166927	Decal, Panel Dash B&S
8 169636	Decal, Rplcmnt
9 163204	Decal, Fender, Craftsman Gold
11 156368	Decal, Fender STLT Oper Inst E/S
13 146046	Decal, V-Belt Dr Sch Tractor

#### KEY PART NO. NO.

KEY PART NO. NO.	DESCRIPTION
15 160396	Decal, Mower Drive Schematic
19 138047	Decal, Battery Diehard Sears
20 166887	Decal, Deck Mower EZ3
22 149516	Decal, Battery
-- 138311	Decal, Lift Handle
-- 154515	Pad Footrest LH STLT
-- 154516	Pad Footrest RH STLT
-- 169905	Owner's Manual, English
-- 169906	Owner's Manual, Spanish

### WHEELS AND TIRES

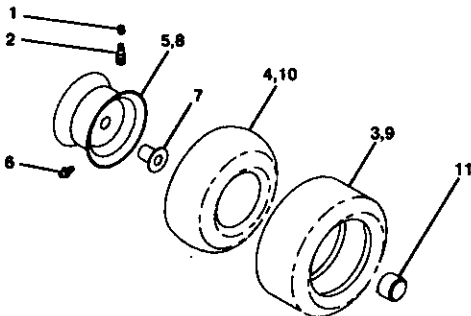

#### KEY PART NO. NO.

KEY PART NO. NO.	DESCRIPTION
1 59192	Valve Cap, Tire
2 65139	Stem, Valve
3 106222X	Tire, Front
4 59904	Tube, Front Tire (Not Provided, Service Item Only)
5 106732X427	Rim, Front
6 278H	Fitting, Grease (Front Wheel Only)
7 9040H	Bearing, Flange (Front Wheel Only)
8 106108X427	Rim, Rear
9 122082X	Tire, Rear
10 7152J	Tube, Rear Tire (Not Provided, Service Item Only)
11 104757X	Cap, Axle
-- 144334	Sealant, Tire 10 oz.

**NOTE:** All component dimensions given in U. S. inches 1 inch = 25/4 mm

TRACTOR--MODEL NUMBER 917.270850

LIFT ASSEMBLY

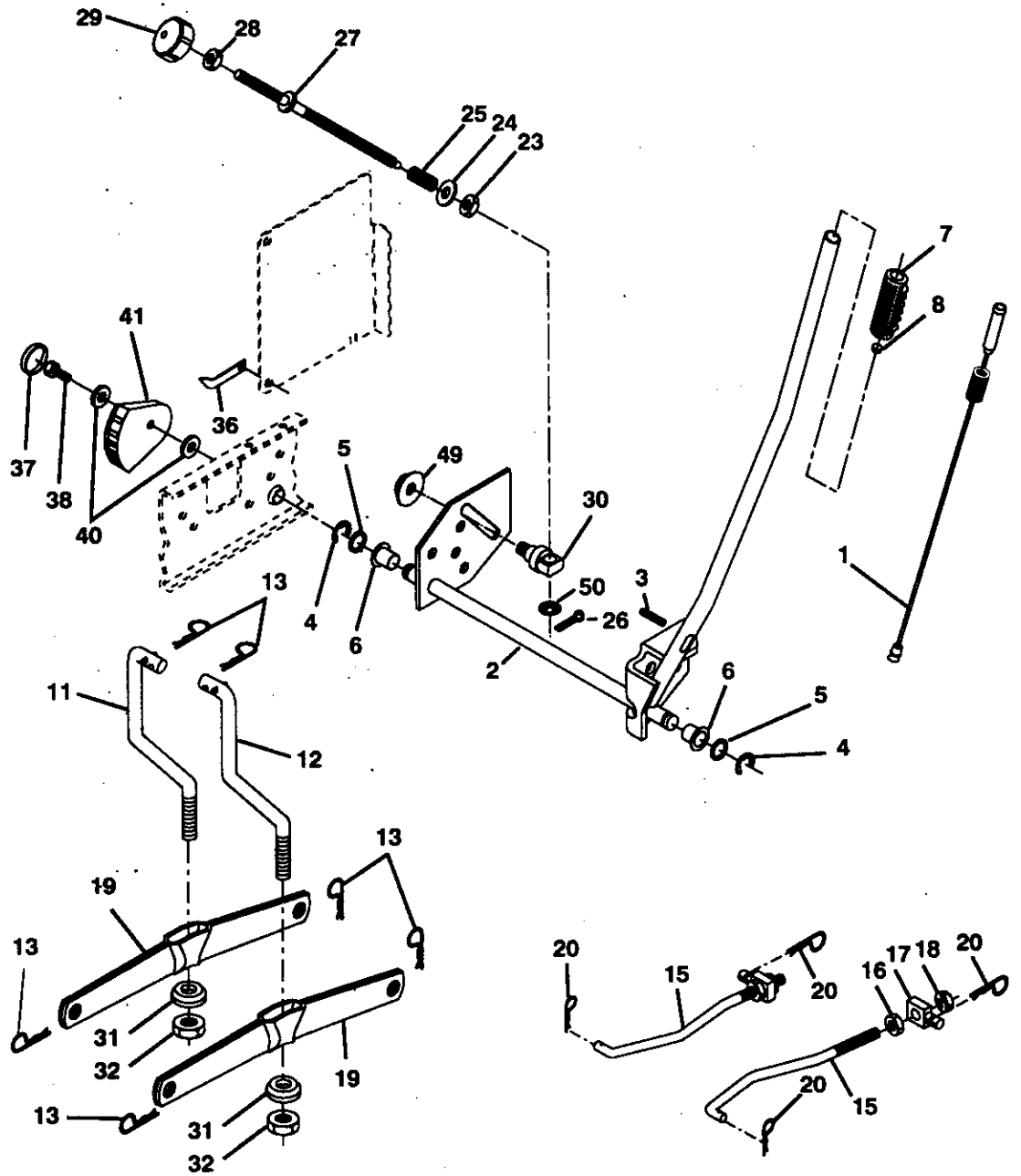

# TRACTOR -- MODEL NUMBER 917.270850

## LIFT ASSEMBLY

KEY PART NO.	PART NO.	DESCRIPTION
1	159460	Lift Lever Inner Wire Assembly
2	159471	Shaft Assembly, Lift
3	105767X	Pin, Groove
4	12000002	E-Ring
5	19211621	Washer 21/32 x 1 x 21 Gauge
6	120183X	Bearing, Nylon
7	125631X	Grip, Handle, Fluted
8	122365X	Button, Plunger, Red
11	139865	Link, Lift, L.H.
12	139866	Link, Lift, R.H.
13	STD624008	Retainer Spring
15	127218	Link, Front
16	73350800	Nut, Hex, Jam 1/2-13 UNC
17	130171	Trunnion
18	73680800	Nut Lock 1/2-13 UNC
19	139868	Arm, Suspension, Rear
20	163552	Retainer Spring
23	110807X	Nut, Special
24	19131016	Washer 13/32 x 5/8 x .16 Gauge
25	2876H	Spring
26	76020308	Pin, Cotter 3/32 x 1/2
27	126971X	Rod, Adjust, Lift
28	73350600	Nut, Hex, Jam 3/8-16 UNC
29	138057	Knob, Inf. 3/8-16
30	150233	Trunnion, Inf Height
31	140302	Bearing, Pvt, Lift Special
32	73540600	Nut, Crownlock 3/8-24
36	155097	Pointer Height Indicator
37	123935X	Plug Hole
38	17490512	Screw Thdrol 5/16-18 x 3/4
40	19112410	Washer 11/32 x 1-1/2
41	155098	Indicator Height
49	145212	Nut Flange Lock
50	110452X	Nut Push Phos & Oil

NOTE: All component dimensions given in U. S.  
inches 1 inch = 25/4 mm

# TRACTOR--MODEL NUMBER 917.270850

## MOWER DECK

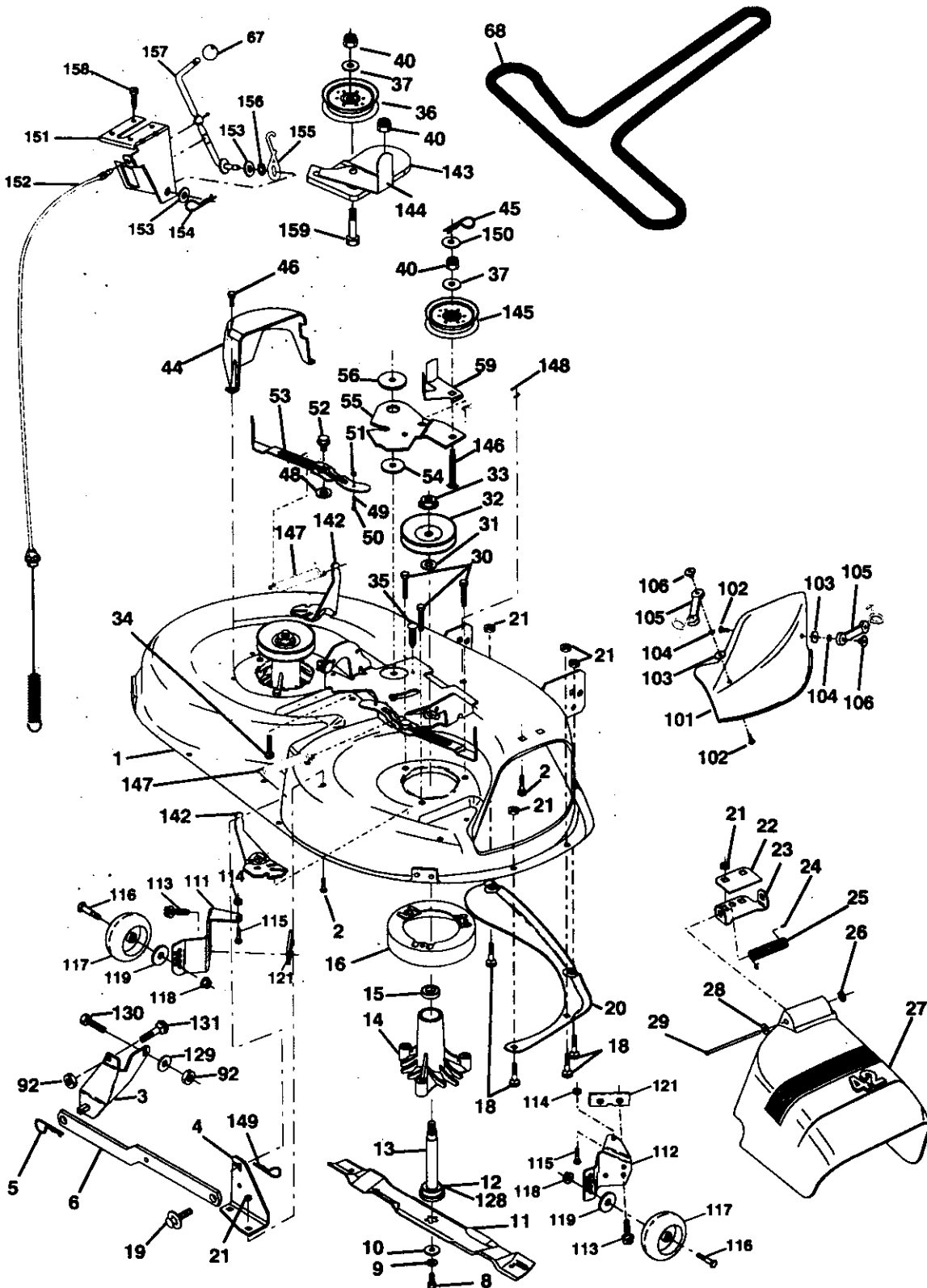

# TRACTOR -- MODEL NUMBER 917.270850

## MOWER DECK

KEY PART NO.	PART NO.	DESCRIPTION	KEY PART NO.	PART NO.	DESCRIPTION
1	165892	Mower Deck Assembly, 42"	56	165723	Spacer, Retainer
2	STD533107	Bolt	59	141043	Guard, TUV Idler
3	138017	Bracket Assembly, Sway Bar, Front	67	149846	Knob Custom Oval V-Belt
4	165460	Bracket Sway Bar 38/42" Deck	68	144959	Nut
5	STD624008	Retainer Spring	92	STD541437	Nut
6	130832	Arm, Suspension, Rear	101	136420	Mulcher Cover
8	850857	Bolt, Hex 3/8-24 x 1.25 Gr. 8	102	71161010	Screw
9	STD551137	Washer, Lock	103	19061216	Washer #10
10	140296	Washer, Hardened	104	STD551110	Washer, Lock
11	134149	Blade, Mulching	105	160793	Latch Assembly, Bagger
12	129895	Bearing, Ball	106	2029J	Nut, Weld
13	137645	Shaft Assembly, Mandrel, Vented (Includes Key Number 12)	111	155197	Bracket, Gauge, Wheel L.H.
14	128774	Housing, Mandrel, Vented	112	155198	Bracket, Gauge, Wheel R.H.
15	110485X	Bearing, Ball, Mandrel	113	17060512	Screw 5/16-18 x 3/4
16	140329	Stripper, Vented Mower Deck	114	STD541431	Nut, Hex, Keps 5/16-18 UNC
18	72140505	Bolt, Carriage 5/16-18 x 5/8	115	72110504	Bolt, Carriage 5/16 UNC x 1/2
19	132827	Bolt, Shoulder	116	4898H	Bolt, Shoulder
20	159770	Baffle, Vortex	117	165746	Wheel, Gauge
21	STD541431	Nut Crownlock 5/16-18 UNC	118	73930600	Nut, Centerlock 3/8-16
22	134753	Stiffener Bracket	119	STD551037	Washer 3/8 x 7/8 x 14 Gauge
23	131267	Bracket, Deflector	121	143723	Bracket
24	105304X	Cap, Sleeve	128	153390	Washer Felt
25	123713X	Spring, Torsion, Deflector	129	19131312	Washer 13/32 x 13/16 x 12 Ga.
26	110452X	Nut, Push	130	STD523710	Bolt, Fin Hex 3/8-16 UNC x 1 Gr. 5
27	130968	Shield, Deflector	131	STD533710	Bolt, Rdhd Sqn 3/8-16UNC x 1
28	19111016	Washer 11/32 x 5/8 x 16 Ga.	142	165890	Arm Spring Brake Mower
29	131491	Rod, Hinge	143	157109	Bracket Arm Idler 42"
30	157722	Screw Thdrol Washer Head	144	158634	Keeper Belt 42" Clutch Cable
31	129963	Washer, Spacer	145	165888	Pulley Idler Flat
32	153535	Pulley, Mandrel	146	165891	Bolt Carriage Idler
33	137266	Nut, Toplock, Flanged	147	131335	Spring Extension
34	STD533717	Bolt	148	169022	Spring Return Idler
35	133835	Fastner, Christmas Tree	149	165898	Retainer Spring Yellow Zinc
36	131494	Pulley, Idler, Flat	150	19091216	Washer 9/32 x 3/4 x 16 Ga.
37	STD551037	Washer 13/32 x 13/16 x 16 Gauge	151	169670	Bracket Clutch
40	STD541437	Nut Crownlock 3/8-16 UNC	152	169676	Cable Clutch 42 In
44	140088	Guard, Mandrel, L.H.	153	169674	Washer Flat 3/8" Type B
45	STD624003	Retainer	154	169675	Spring Retainer
46	137729	Screw, Thd. Roll 1/4-20 x 5/8	155	169671	Spring Retention Lever
48	133944	Washer, Hardened	156	169672	Spacer
49	155066	Roller Assembly, Cam Follower	157	169669	Rod Clutch
50	131340	Bolt, Shoulder #10-24 Grade 5	158	17720410	Screw Hex Thd Cut 1/4-20 x 5/8
51	STD541410	Locknut	159	STD533717	Bolt Rdhd Sqn 3/8-16Unc x 1-3/4
52	139888	Bolt, Shoulder 5/16-18 UNC	--	130794	Mandrel Assembly (Includes Key Numbers 8-10, 12-15, 31 and 32)
53	131845	Arm Assembly, Pad, Brake	--	169583	Mower Deck, Complete (Standard Deck, Order Separately Mulcher Plate and Gauge Wheel Components, Key Nos. 101-106 and 111-121)
54	133943	Washer, Hardened			
55	155046	Arm, Idler			

**NOTE:** All component dimensions given in U. S. inches 1 inch = 25/4 mm

**TRACTOR--MODEL NUMBER 917.270850**  
**PEERLESS TRANSAXLE--MODEL NUMBER 206-545C**

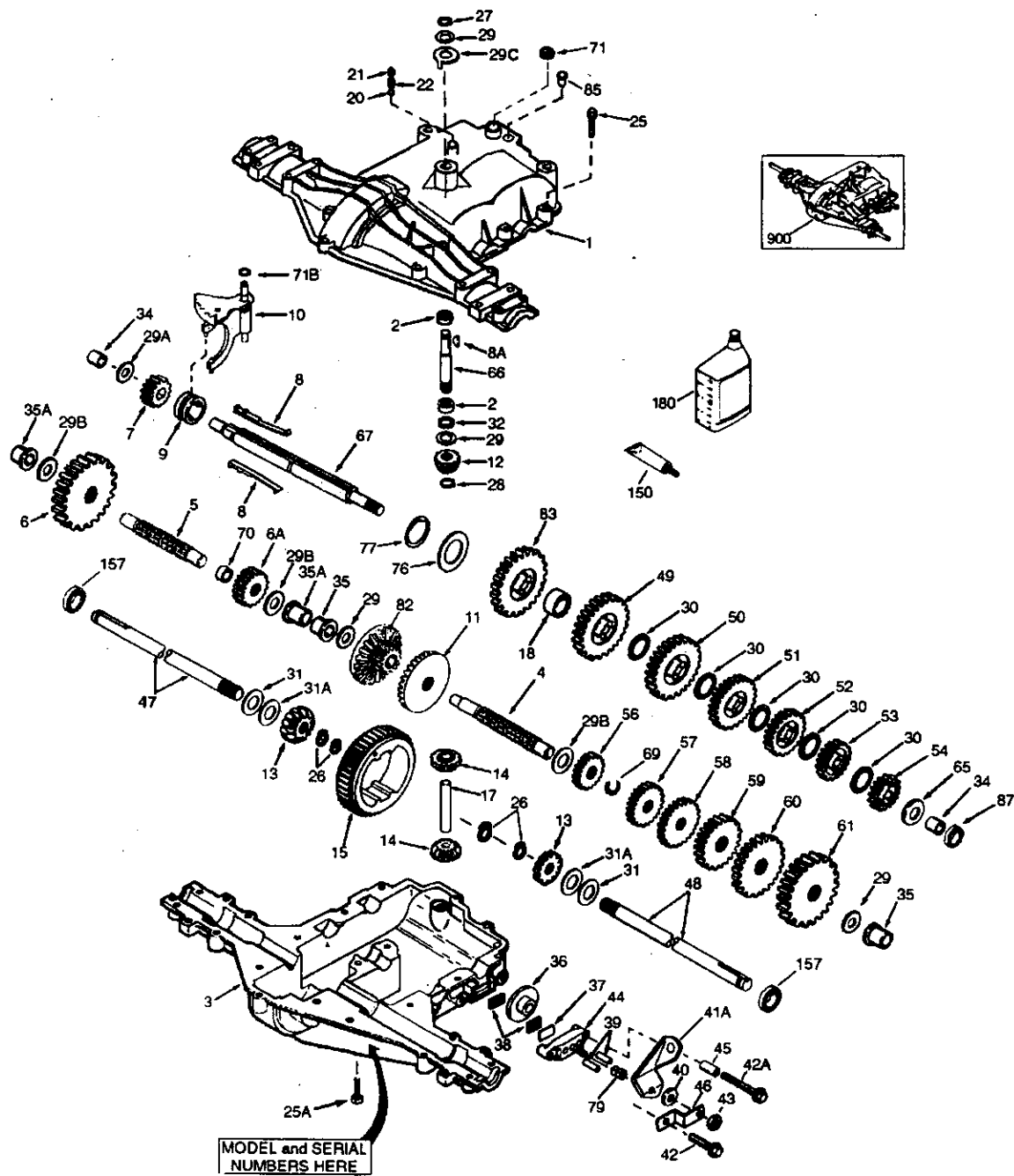



**TRACTOR--MODEL NUMBER 917.270850**  
**PEERLESS TRANSAXLE--MODEL NUMBER 206-545C**

KEY PART NO. NO.	DESCRIPTION	KEY PART NO. NO.	DESCRIPTION
1	772147 Transaxle Cover	39	786026 Dowel Pin
2	780086A Needle Bearing 5/8"	40	792076A Flat Washer .312 ID x .059W
3	770128 Transaxle Case	41A	790079 Brake Lever
4	776395 Countershaft	42	792073A Screw 1/4 - 20 x 1-1/4"
5	776409 Output Shaft	42A	792085A Screw 1/4 - 20 x 2 1/4"
6	778364 Spur Gear (38 teeth)	43	792075 Locknut 5 / 16 - 24
6A	778369 Spur Gear (15 teeth)	44	790025 Brake Pad Holder
7	778330 Spur Gear (11 teeth)	45	786066 Spacer .2625 x 1.0
8	792180 Shift Key	46	786086 Brake Lever Bracket
8A	792047 Woodruff Key #9	47	774690 Axle (11-15 / 16" Long)
9	784352 Shift Collar	48	774691 Axle (16 - 1 / 2" long)
10	784378 Shift Rod & Fork	49	778356 Spur Gear (29 teeth)
11	778334 Bevel Gear (30 teeth)	50	778338 Spur Gear (27 teeth)
12	778309 Input Bevel Pinion (13 teeth)	51	778354 Spur Gear (23 teeth)
13	778368 Bevel Gear (13 teeth) (Include. 14)	52	778352 Spur Gear (19 teeth)
14	778368 Bevel Pinion (13 teeth) (Include. 13)	53	778350 Spur Gear (16 teeth)
15	778370 Ring Gear (43 teeth)	54	778346 Spur Gear (15 teeth)
17	786188 Drive Pin	56	778355 Spur Gear (11 teeth)
18	786102 Spacer 1.130 X .695	57	778337 Spur Gear (13 teeth)
20	792077A Ball 5/16" dia	58	778353 Spur Gear (17 teeth)
21	792078 Set Screw 3/8 - 16 x 3/8"	59	778351 Spur Gear (21 teeth)
22	792079 Spring .310 OD x .625 L	60	778349 Spur Gear (24 teeth)
25	792073A Screw 1/4 - 20 x 1-1/4"	61	778345 Spur Gear (25 teeth)
25A	792177 Screw 1/4-20 x 1-3/8"	65	780189 Flat Washer .563 ID x .062W
26	792125 Retaining Ring (pkg of 2)	66	776422 Input Shaft
27	792035 Retaining Ring	67	776396 Shifter & Brake Shaft
28	788040 Retaining Ring	69	792170 Retaining Ring
29	780072 Thrust Washer .627 ID x .031W	70	786187 Spacer .890
29A	780160 Thrust Washer .762 ID x .031W	71	788069 Square Cut Ring
29B	780051 Thrust Washer .762 ID x .031W	71B	788092 "O" Ring
29C	780199 Anti-Rotation Washer .632	76	780090 Flat Washer 1.128 ID x .058W
30	780108 Cup Washer 1.127 ID x .032W	77	788078A Inverted Retaining Ring
31	780001 Flat Washer .750 ID x .056W (Use As Needed)	79	792144 Spring .430 OD x .5000 L
31A	780195 Flat Washer .750 ID x .062W	82	778333 Bevel & Spur Gear (30 & 13 teeth)
32	788083 Oil Seal 5/8"	83	778338 Spur Gear (27 teeth)
34	780194 Bushing .563	85	792154 Oil Fill Plug
35	780193 Flanged Bushing 5 / 8" ID	87	788089A Oil Seal 9 / 16"
35A	780197 Flanged Bushing .751	150	788093A Liquid Gasket RTV Silicone
36	790075 Brake Disk	157	788088A Oil Seal 3 / 4"
37	790007 Brake Pad Plate	180	730229A Gear Oil 80W90
38	799021 Brake Pad (pkg of 2)	900	794712 Replacement MST 206-545C Transaxle

**NOTE:** All component dimensions given in U.S. inches 1 inch = 25.4 mm

**TRACTOR--MODEL NUMBER 917.270850**

**BRIGGS & STRATTON ENGINE-MODEL NUMBER 461707, TYPE NUMBER 0145-E1**

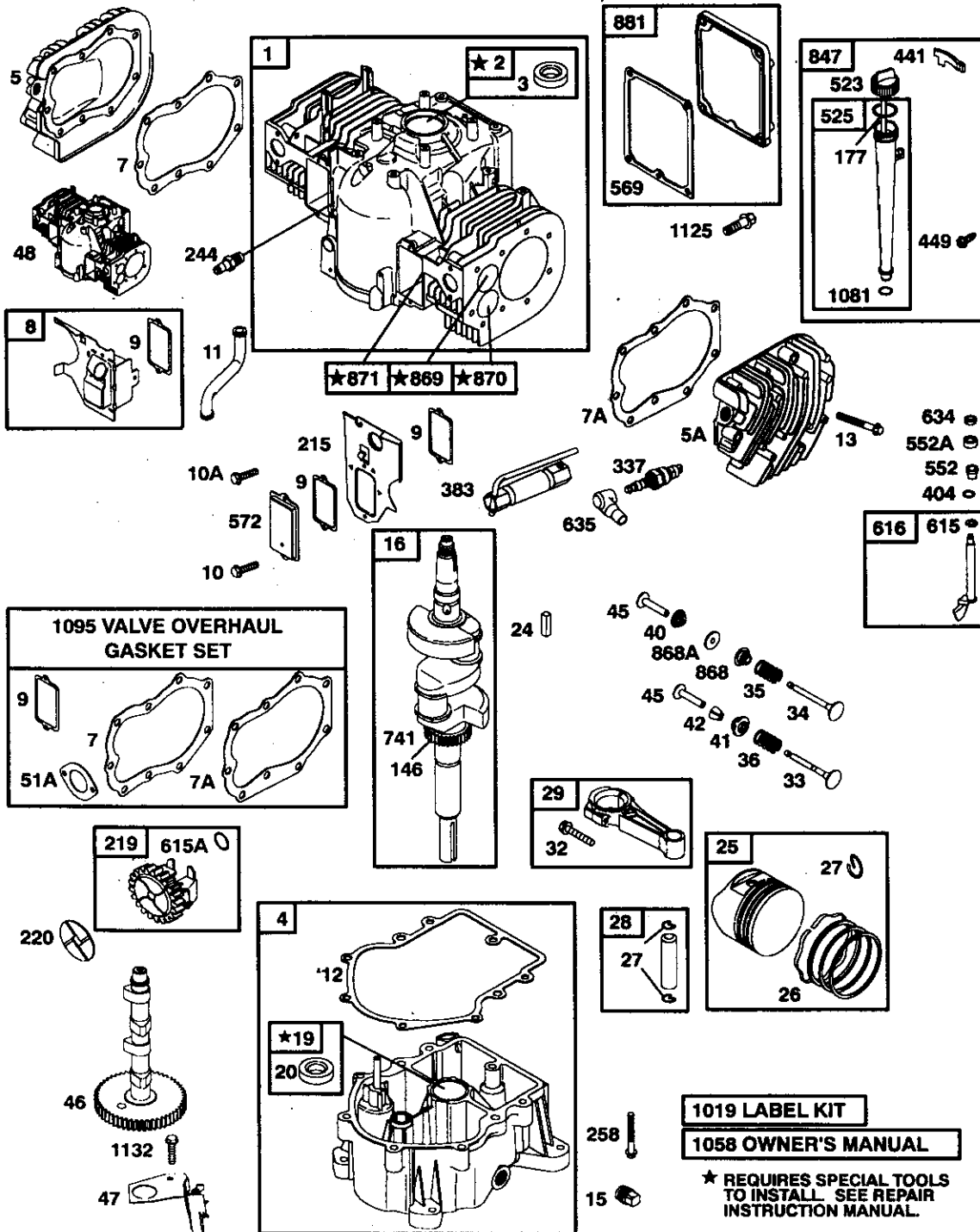

**TRACTOR--MODEL NUMBER 917.270850**

**BRIGGS & STRATTON ENGINE-MODEL NUMBER 461707, TYPE NUMBER 0145-E1**

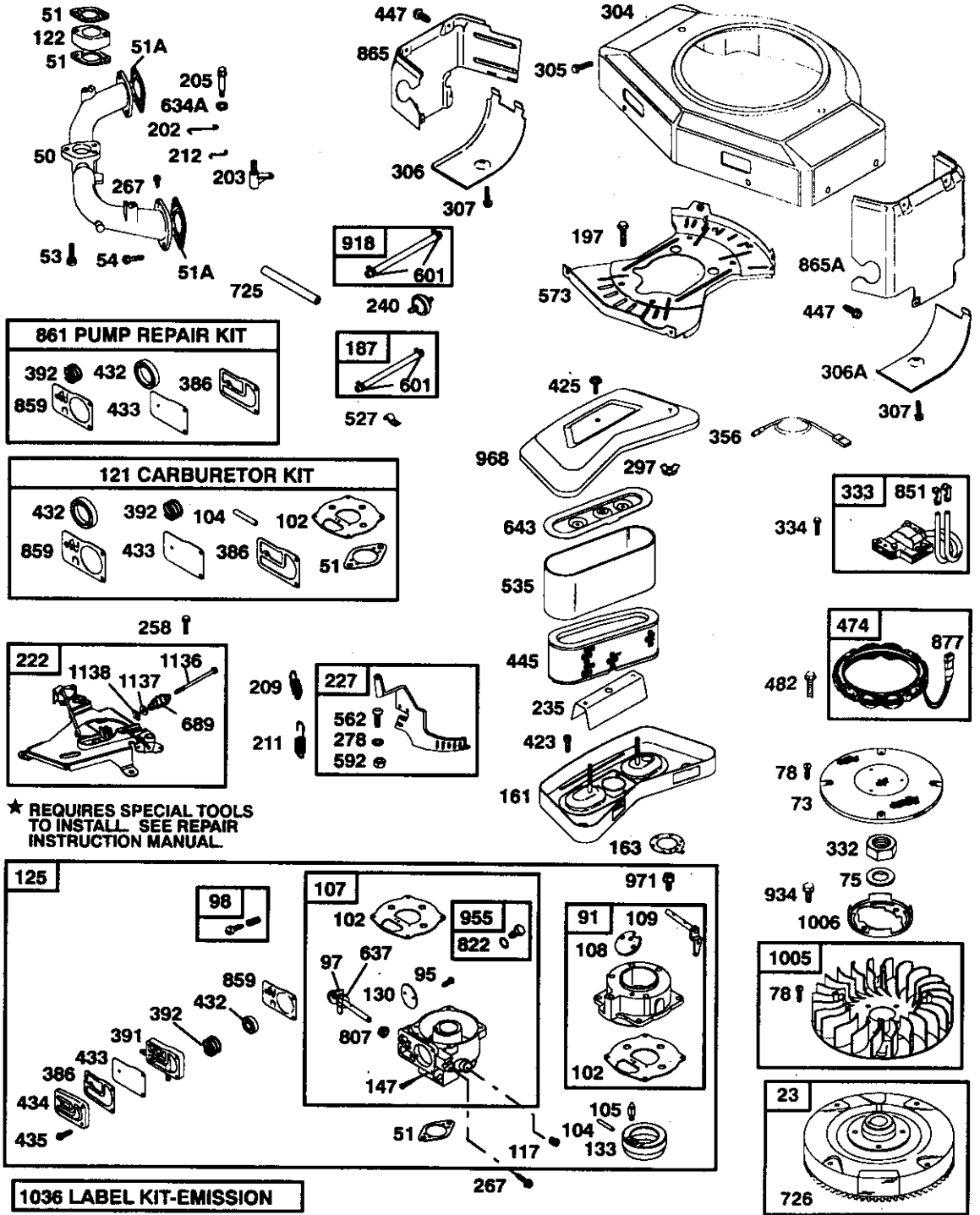

**TRACTOR--MODEL NUMBER 917.270850**

**BRIGGS & STRATTON ENGINE-MODEL NUMBER 461707, TYPE NUMBER 0145-E1**

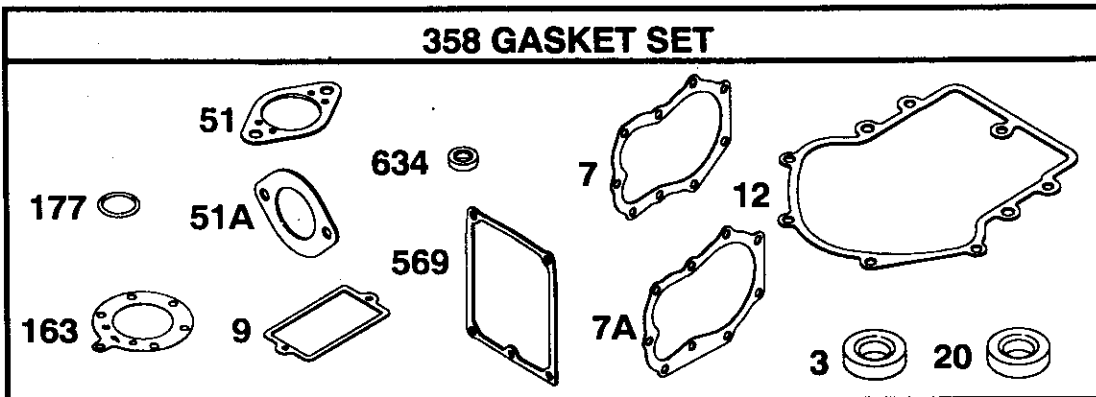
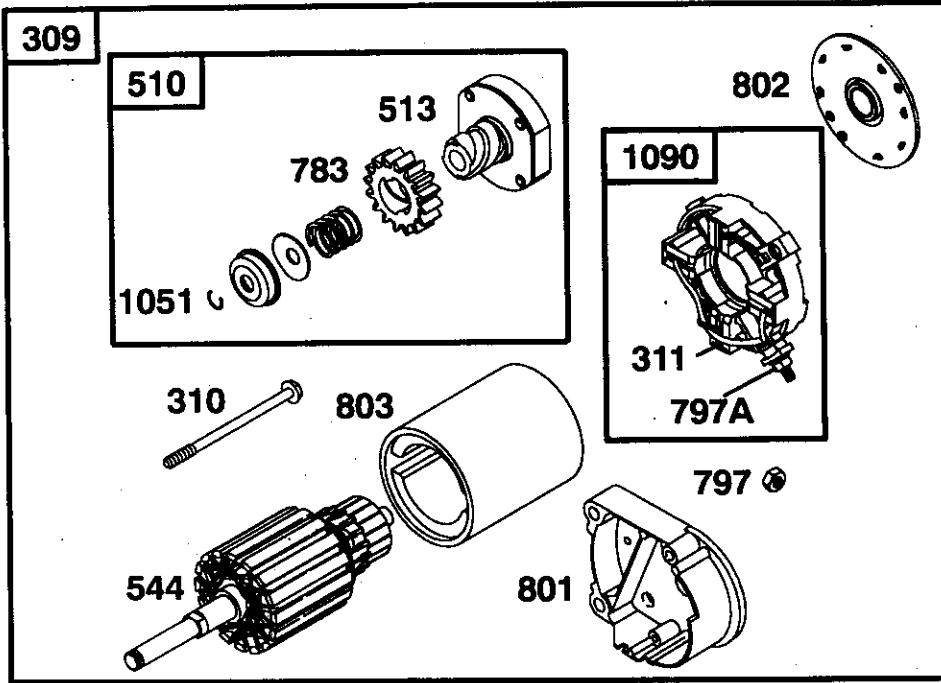

# TRACTOR--MODEL NUMBER 917.270850

## BRIGGS & STRATTON ENGINE-MODEL NUMBER 461707, TYPE NUMBER 0145-E1

KEY NO.	PART NO.	DESCRIPTION	KEY NO.	PART NO.	DESCRIPTION
1	498583	Cylinder Assembly	48	498542	Short Block
2	399265	Bushing/Seal Kit	50	213290	Manifold-Intake
3	91086	★ Seal-Oil	51	271412	★● Gasket-Intake
4	493304	Sump-Engine	51A	270884	★◆ Gasket-Intake
5	214517	Head-Cylinder #1	53	93970	Screw (Carburetor)
5A	214518	Head-Cylinder #2	54	93208	Screw (Intake Manifold)
7	271867	★◆ Gasket-Cylinder Head #1	73	691438	Screen-Rotating
7A	271868	★◆ Gasket-Cylinder Head #2	75	222511	Washer (Flywheel)
8	495754	Breather Assembly (Cylinder #1)	78	691134	Screw (Flywheel Fan)
9	27803	★◆ Gasket-Breather	91	693483	Body Assembly-Upper
10	94382	Screw (Breather Assembly)	95	690718	Screw (Throttle Valve)
10A	94380	Screw (Breather Cover)	97	693485	Shaft-Throttle
11	280225	Tube-Breather	98	807923	Kit-Idle Speed
	273390	★ Gasket-Crankcase (.015" Thick, Std.)	102	693509	● Gasket-Carburetor Body
	271188	★ Gasket-Crankcase (.005" Thick)	104	693506	● Pin-Float Hinge
	271189	★ Gasket-Crankcase (.009" Thick)	105	692078	● Valve-Float Needle
13	94565	Screw (Cylinder Head)	107	693482	Body Assembly-Lower
15	94239	Plug-Oil Drain	108	693505	Valve-Choke
16	690666	Crankshaft	109	693498	Shaft-Choke
19	399264	Bushing	117	693538	Jet-Main
20	291675	★ Seal-Oil		693500	Jet-Main (High Altitude)
23	491180	Flywheel	121	491539	Carburetor Kit
24	222698	Key-Flywheel	122	281411	Spacer
25	499180	Piston Assembly (Standard)	125	693479	Carburetor
	499181	Piston Assembly (.010 "O.S.)	130	693504	Valve-Throttle
	499182	Piston Assembly (.020" O.S.)	133	693512	Float-Carburetor
	499183	Piston Assembly (.030" O.S.)	146	94196	Key-Timing
26	499184	Ring Set, Piston (Standard)	147	693508	Jet-Pilot
	499285	Ring Set, Piston (.010 "O.S.)	161	496599	Base-Air Cleaner
	499186	Ring Set, Piston (.020 "O.S.)	163	271411	★ Gasket-Air Cleaner
	499187	Ring Set, Piston (.030 "O.S.)	177	271170	★ Seal-O-Ring
27	263129	Lock-Piston Pin	187	299146	Line-Fuel (Cut to Required Length)
28	498319	Pin Assembly, Piston (Std.)	197	95063	Screw (Back Plate)
	498320	Pin Assembly-Piston (.005" O.S.)	202	262683	Link-Mechanical Governor
29	498314	Rod-Connecting (Standard)	203	280997	Crank-Bell
	498541	Rod-Connecting (.020 U.S.)	205	93971	Screw (Bell Crank)
32	95017	Screw (Connecting Rod)	209	262352	Spring-Governor
33	390420	Valve-Exhaust (Include(s): Keeper-Valve (Ref. No. 42))	211	261563	Spring-Governor
	494553	Valve-Intake	212	693985	Link-Throttle
34	691302	Spring-Valve (Intake)	215	224816	Guide-Air
35	65906	Spring-Valve (Exhaust)	219	394348	Gear-Governor
36	26828	Retainer-Valve (Exhaust)	220	222773	Washer-Thrust (Governor Gear)
40	221596	Retainer-Valve (Exhaust)	222	491282	Bracket-Control
41	292260	Keeper-Valve	227	491297	Lever-Governor
42	494553	Keeper-Valve	235	224995	Shield-Fuel Spray
45	261368	Tappet-Valve	240	394358	Filter-Fuel
46	214487	Camshaft	244	230318	Connector-Hose (Pulse Line)
47	393415	Slinger-Oil	258	94930	Screw (Engine Sump)
			267	93897	Screw (Casing Clamp)
			278	94942	Washer (Governor Lever)
			297	94289	Nut-Wing (Air Filter Retainer)
			304	691390	Housing-Blower
			305	690960	Screw (Blower Housing)
			306	222846	Shield-Cylinder
			306A	223734	Shield-Cylinder
			307	94930	Screw (Cylinder Shield)
			309	497596	Motor-Starter
			310	94003	Bolt (Starter Motor)
			311	497608	Brush Set

## TRACTOR--MODEL NUMBER 917.270850

**BRIGGS & STRATTON ENGINE-MODEL NUMBER 461707, TYPE NUMBER 0145-E1**

KEY NO.	PART NO.	DESCRIPTION	KEY NO.	PART NO.	DESCRIPTION
332	230674	Nut (Flywheel)	802	497607	Cap-End
333	394891	Armature-Magneto	803	497604	Housing-Starter
334	94731	Screw (Magneto Armature)	807	693511	Spacer
337	802592	Plug-Spark	822	693497	Washer-Seal (Throttle Shaft)
356	494705	Wire-Stop			
358	495868	Gasket Set	847	495715	Dipstick/Tube Assembly
383	89838	Wrench-Spark Plug	851	493880	Terminal-Cable
386	693490	●+ Gasket-Pump	859	693488	●+ Diaphragm-Fuel Pump
391	693487	Body-Pump	861	393397	Kit-Fuel Pump
392	693491	●+ Spring-Pump Diaphragm	865	224774	Cover-Air Guide
404	223882	Washer (Governor Crank)	865A	224775	Cover-Air Guide
423	94674	Screw (Air Cleaner Base)	868	497656	Seal-Valve
425	94823	Screw (Air Cleaner Cover)	868A	273312	Seal-Valve
432	693492	●+ Cap-Spring	869	261463	Seat-Valve (Intake)
433	693489	●+ Diaphragm-Fuel Pump	870	262924	Seat-Valve (Exhaust)
434	693493	Cover-Diaphragm	871	261961	Bushing-Guide (Exhaust)
435	693494	Screw (Diaphragm Cover)		231218	Bushing-Guide (Intake)
441	222875	Bracket-Oil Fill	877	393456	Wire-Alternator
445	394019	Filter-Air	881	495901	Plate-Cover
447	93343	Screw (Air Guide Cover)	918	393815	Hose-Vacuum (Cylinder-To-Impulse Pump)(Cut to Required Length)
449	94882	Screw (Oil Fill Bracket)			
474	93474	Alternator			
482	93621	Screw (Alternator)	934	94627	Screw (Fan Retainer)
510	497606	Drive-Starter	955	693513	Plug-Carburetor
513	398003	Clutch-Drive	968	225008	Cover-Air Cleaner
523	494947	Dipstick	971	805540	Screw (Upper Body To Lower Body)
525	495348	Tube-Oil Fill			
527	223167	Clamp-Tube	1005	498157	Fan-Flywheel
535	272490	Filter-Air	1006	224901	Retainer-Fan
544	97603	Armature-Starter	1019	496726	Label Kit
552	262332	Bushing (Governor Crank)	1036	499382	Label Kit-Emission
552A	262331	Bushing (Governor Crank)	1051	263080	Ring-Retaining
562	93853	Bolt-Carriage (Governor Lever)	1058	273688	Owner's Manual
			1081	280860	★ Seal-O-Ring
569	272645	★ Gasket-Base	1090	497605	Retainer-Brush
572	222892	Cover-Breather (Cylinder #2)	1095	498047	Gasket Set-Valve Overhaul
			1125	94724	Screw (Cover Plate)
573	491304	Plate-Back	1132	94675	Screw (Oil Slinger)
592	92278	Nut (Governor Lever)	1136	94297	Screw (Governor, Control Rod)
601	95162	Clamp-Hose			
615	94296	Retainer (Governor Crank)	1137	220680	Washer (Governor, Control Rod)
615A	93898	Retainer-Governor Shaft			
616	491530	Crank-Governor	1138	94298	Nut (Governor, Control Rod)
634	491287	★ Seal-Governor Shaft	---		460707-0145-E1 Replacement Engine
634A	271013	Washer-Foam			
635	66538	Boot-Spark Plug			
637	693510	Washer-Seal			
643	496700	Retainer-Air Filter	★		Included in Gasket Set, Ref Number 358.
689	262337	Spring-Friction	●		Included in Carburetor Kit, Ref Number 121.
697	93585	Screw (Drive Cap)	◆		Included in Valve Overhaul Kit, Ref Number 1095.
725	280866	Shield-Heat	+		Included in Fuel Pump Kit, Ref Number 861
726	91362	Gear-Ring	★ ● ◆ +		
741	262989	Gear-Timing			
783	693059	Gear-Starter			
797	94010	Nut (Starter Terminal)			
797A	693167	Nut (Starter Terminal)			
801	394860	Cap-Drive			

**NOTE:** All component dimensions given in U.S. inches 1 inch = 25.4 mm

## SUGGESTED GUIDE FOR SIGHTING SLOPES FOR SAFE OPERATION

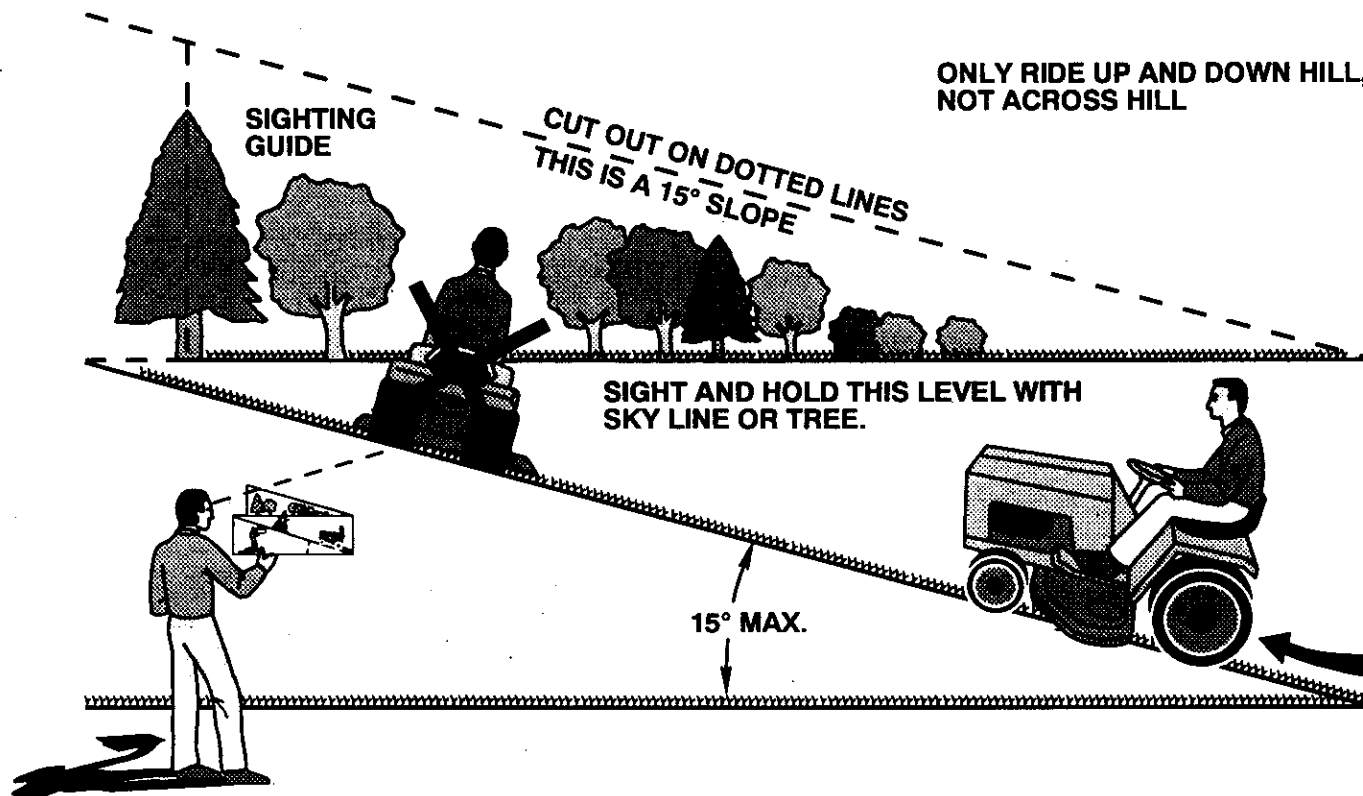

Operate your Tractor up and down the face of slopes (not greater than 15°), never across the face. Make turns gradually to prevent tipping or loss of control. Exercise extreme caution when changing direction on slopes.

**For in-home major brand repair service:**  
Call 24 hours a day, 7 days a week

**1-800-4-MY-HOME<sup>SM</sup>** (1-800-469-4663)  
**Para pedir servicio de reparación a domicilio**  
**1-800-676-5811**

In Canada for all your service and parts needs call  
Au Canada pour tout le service ou les pièces  
**1-800-665-4455**

**For the repair or replacement parts you need:**  
Call 6 am - 11 pm CST, 7 days a week  
**PartsDirect<sup>SM</sup>**  
**1-800-366-PART** (1-800-366-7278)

**Para ordenar piezas con entrega a domicilio**  
**1-800-659-7084**

**For the location of a Sears Parts and Repair Center**  
**in your area:**  
Call 24 hours a day, 7 days a week  
**1-800-488-1222**

**For information on purchasing a Sears Maintenance**  
**Agreement or to inquire about an existing Agreement:**  
Call 9 am - 5 pm, Monday - Saturday  
**1-800-827-6655**

