

Owner's Manual

CRAFTSMAN®

Variable Speed / 1 Inch Stroke Double Insulated **ELECTRONIC RECIPROCATING SAW**

Model Nos.
315.171071
315.171081

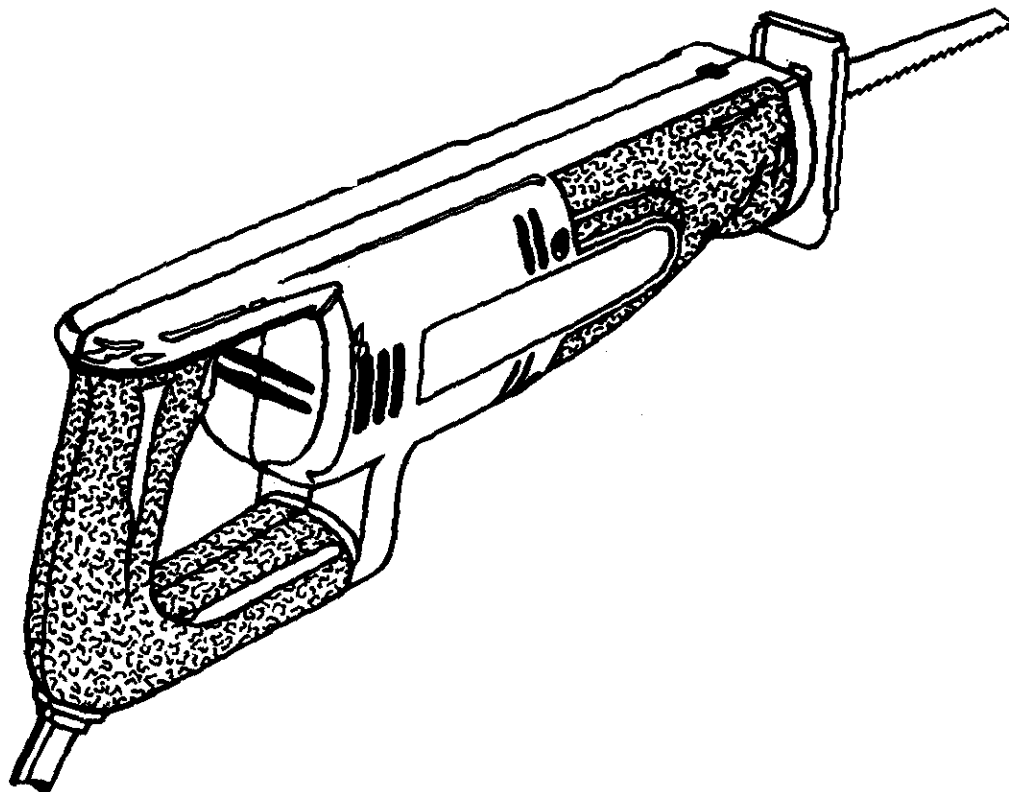

Save this manual for
future reference

⚠ CAUTION: Read and follow all Safety Rules and Operating Instructions before first use of this product.

Customer Help Line: 1-800-932-3188

Sears Roebuck and Co., Hoffman Estates, IL 60179 USA
Visit the Craftsman web page: www.sears.com/craftsman

- Safety
- Features
- Adjustments
- Operation
- Maintenance
- Parts List



TABLE OF CONTENTS

■ Table Of Contents	2
■ Warranty	2
■ Introduction	2
■ Rules For Safe Operation	3-5
■ Product Specifications	6
■ Unpacking	6
■ Accessories	6
■ Features	7-8
■ Adjustments	9-10
■ Operation	10-11
■ Maintenance	12
■ Exploded View and Repair Parts List	13
■ Parts Ordering / Service	14

WARRANTY

FULL ONE YEAR WARRANTY ON CRAFTSMAN ELECTRONIC RECIPROCATING SAW

If this **CRAFTSMAN** Electronic Reciprocating Saw fails to give complete satisfaction within one year from the date of purchase, **RETURN IT TO THE NEAREST SEARS STORE IN THE UNITED STATES**, and Sears will repair it, free of charge.

If this **CRAFTSMAN** Electronic Reciprocating Saw is used for commercial or rental purposes, this warranty applies for only 90 days from the date of purchase.

This warranty gives you specific legal rights, and you may also have other rights which vary from state to state.

Sears, Roebuck and Co., Dept. 817WA, Hoffman Estates, IL 60179

INTRODUCTION

Your reciprocating saw has many features for making cutting operations more pleasant and enjoyable. Safety, performance and dependability have been given top priority in the design of this saw making it easy to maintain and operate.

 **CAUTION:** Carefully read through this entire owner's manual before using your new reciprocating saw. Pay close attention to the Rules For Safe Operation, Warnings and Cautions. If you use your reciprocating saw properly and only for what it is intended, you will enjoy years of safe, reliable service.

RULES FOR SAFE OPERATION

The purpose of safety symbols is to attract your attention to possible dangers. The safety symbols, and the explanations with them, deserve your careful attention and understanding. The safety warnings do not by themselves eliminate any danger. The instructions or warnings they give are not substitutes for proper accident prevention measures.

SYMBOL MEANING



SAFETY ALERT SYMBOL:

Indicates warning or caution. May be used in conjunction with other symbols or pictographs.



WARNING: Failure to obey a safety warning can result in serious injury to yourself or to others. Always follow the safety precautions to reduce the risk of fire, electric shock and personal injury.



CAUTION: Failure to obey a safety warning may result in property damage or personal injury to yourself or to others. Always follow the safety precautions to reduce the risk of fire, electric shock and personal injury.

NOTE: Advises you of information or instructions vital to the operation or maintenance of the equipment.

DOUBLE INSULATION

Double insulation is a concept in safety, in electric power tools which eliminates the need for the usual three-wire grounded power cord. All exposed metal parts are isolated from internal metal motor components with protecting insulation. Double insulated tools do not need to be grounded.

 **WARNING:** Do not attempt to operate this tool until you have read thoroughly and understand completely all instructions, safety rules, etc. contained in this manual. Failure to comply can result in accidents involving fire, electric shock, or serious personal injury. Save owner's manual and review frequently for continuing safe operation, and instructing others who may use this tool.

READ ALL INSTRUCTIONS

- **KNOW YOUR POWER TOOL.** Read owner's manual carefully. Learn its applications and limitations as well as the specific potential hazards related to this tool.
- **GUARD AGAINST ELECTRICAL SHOCK** by preventing body contact with grounded surfaces. For example; pipes, radiators, ranges, refrigerator enclosures.
- **KEEP GUARDS IN PLACE** and in working order.
- **KEEP WORK AREA CLEAN.** Cluttered areas and benches invite accidents.

IMPORTANT

Servicing of a tool with double insulation requires extreme care and knowledge of the system and should be performed only by a qualified service technician. For service we suggest you return the tool to your nearest Sears Store for repair. Always use original factory replacement parts when servicing.

- **AVOID DANGEROUS ENVIRONMENT.** Don't use power tools in damp or wet locations or expose to rain. Keep work area well lit.
- **KEEP CHILDREN AND VISITORS AWAY.** All visitors should wear safety glasses and be kept a safe distance from work area. Do not let visitors contact tool or extension cord.
- **STORE IDLE TOOLS.** When not in use, tools should be stored in a dry and high or locked-up place – out of the reach of children.
- **DON'T FORCE TOOL.** It will do the job better and safer at the rate for which it was designed.
- **USE RIGHT TOOL.** Don't force small tool or attachment to do the job of a heavy duty tool. Don't use tool for purpose not intended – for example – A circular saw should never be used for cutting tree limbs or logs.
- **WEAR PROPER APPAREL.** Do not wear loose clothing or jewelry that can get caught in tool's moving parts and cause personal injury. Rubber gloves and nonskid footwear are recommended when working outdoors. Wear protective hair covering to contain long hair and keep it from being drawn into nearby air vents.

RULES FOR SAFE OPERATION (Continued)

- **ALWAYS WEAR SAFETY GLASSES.** Everyday eyeglasses have only impact-resistant lenses; they are **not** safety glasses.
- **PROTECT YOUR LUNGS.** Wear a face or dust mask if the cutting operation is dusty.
- **PROTECT YOUR HEARING.** Wear hearing protection during extended periods of operation.
- **DON'T ABUSE CORD.** Never carry tool by cord or yank it to disconnect from receptacle. Keep cord from heat, oil, and sharp edges.
- **SECURE WORK.** Use clamps or a vise to hold work. It's safer than using your hand and it frees both hands to operate tool.
- **DON'T OVERREACH.** Keep proper footing and balance at all times. Do not use on a ladder or unstable support.
- **MAINTAIN TOOLS WITH CARE.** Keep tools sharp and clean for best and safest performance. Follow instructions for lubricating and changing accessories.
- **DISCONNECT TOOLS.** When not in use, before servicing, or when changing attachments, blades, bits, cutters, etc., all tools should be disconnected from power supply.
- **REMOVE ADJUSTING KEYS AND WRENCHES.** Form habit of checking to see that keys and adjusting wrenches are removed from tool before turning it on.
- **AVOID ACCIDENTAL STARTING.** Don't carry plugged-in tool with finger on switch. Be sure switch is off when plugging in.
- **MAKE SURE YOUR EXTENSION CORD IS IN GOOD CONDITION.** When using an extension cord, be sure to use one heavy enough to carry the current your product will draw. An undersized cord will cause a drop in line voltage resulting in loss of power and overheating. A wire gage size (A.W.G.) of at least 14 is recommended for an extension cord 100 feet or less in length. A cord exceeding 100 feet is not recommended. If in doubt, use the next heavier gage. The smaller the gage number, the heavier the cord.
- **OUTDOOR USE EXTENSION CORDS.** When tool is used outdoors, use only extension cords suitable for use outdoors. Outdoor approved cords are marked with the suffix W-A, for example - SJTW-A or SJOW-A.
- **KEEP BLADES CLEAN AND SHARP.** Sharp blades minimize stalling and kickback.
- **KEEP HANDS AWAY FROM CUTTING AREA.** Keep hands away from blades. Do not reach underneath work while blade is cutting. Do not attempt to remove cut material while blade is cutting.
- **NEVER USE IN AN EXPLOSIVE ATMOSPHERE.** Normal sparking of the motor could ignite fumes.
- **INSPECT TOOL CORDS PERIODICALLY** and if damaged, have repaired by authorized service facility. Stay constantly aware of cord location and keep it well away from the blade.
- **INSPECT EXTENSION CORDS PERIODICALLY** and replace if damaged.
- **KEEP HANDLES DRY, CLEAN, AND FREE FROM OIL AND GREASE.** Always use a clean cloth when cleaning. Never use brake fluids, gasoline, petroleum-based products, or any strong solvents to clean your tool.
- **STAY ALERT.** Watch what you are doing and use common sense. Do not operate tool when you are tired. Do not rush.
- **CHECK DAMAGED PARTS.** Before further use of the tool, a guard or other part that is damaged should be carefully checked to determine that it will operate properly and perform its intended function. Check for alignment of moving parts, binding of moving parts, breakage of parts, mounting and any other conditions that may affect its operation. A guard or other part that is damaged should be properly repaired or replaced by an authorized service center unless indicated elsewhere in this instruction manual.
- **DO NOT USE TOOL IF SWITCH DOES NOT TURN IT ON AND OFF.** Have defective switches replaced by an authorized service center.
- **CUTTING INTO ELECTRICAL WIRING IN WALLS CAN CAUSE BLADE, BLADE CLAMP, AND SAW BAR ASSEMBLY TO BECOME ELECTRICALLY LIVE.** Do not touch metal parts when cutting into a wall; grasp only the insulated handle(s) provided on the tool. Make sure hidden electrical wiring, water pipes, and mechanical hazards are not in the blade path when cutting into a wall.
- **INSPECT FOR** and remove all nails from lumber before cutting.
- **NEVER** touch the blade or other moving parts during use.
- **NEVER** lay a tool down before its moving parts have come to a complete stop.

RULES FOR SAFE OPERATION (Continued)

- **DO NOT** operate this tool while under the influence of drugs, alcohol, or any medication.
- **POLARIZED PLUGS.** To reduce the risk of electric shock, this tool has a polarized plug (one blade is wider than the other). This plug will fit in a polarized outlet only one way. If the plug does not fit fully in the outlet, reverse the plug. If it still does not fit, contact a qualified electrician to install the proper outlet. Do not change the plug in any way.
- **WHEN SERVICING USE ONLY IDENTICAL CRAFTSMAN REPLACEMENT PARTS.**
- **SAVE THESE INSTRUCTIONS.** Refer to them frequently and use them to instruct others who may use this tool. If you loan someone this tool, loan them these instructions also.

 Look for this symbol to point out important safety precautions. It means attention!!! Your safety is involved.

WARNING:



The operation of any reciprocating saw can result in foreign objects being thrown into your eyes, which can result in severe eye damage. Before beginning power tool operation, always wear safety goggles or safety glasses with side shields and a full face shield when needed. We recommend Wide Vision Safety Mask for use over eyeglasses or standard safety glasses with side shields, available at Sears Retail Stores.

SAVE THESE INSTRUCTIONS

PRODUCT SPECIFICATIONS

Blade Stroke	1 in.	No Load Speed	0 - 2500 SPM
Horsepower	3/4	Switch	Variable Speed
Input	6.0 Amperes	Shank Capacity	1/2 in.
Rating	120 volts, 60 Hz, AC		

UNPACKING

Your reciprocating saw has been shipped completely assembled except for the blade. Inspect it carefully to make sure no breakage or damage has occurred during shipping. If any parts are damaged or missing, contact your nearest Sears Retail Store to obtain replacement parts before attempting to operate saw. An allen wrench, three blades, and this owner's manual are included with saw Model No. 315.171071. It also comes packed in a carrying case. An allen

wrench, one blade, and this owner's manual are included with saw Model No. 315.171081. The carrying case can be purchased separately for Model No. 315.171081 at your nearest Sears Retail Store.

 **WARNING:** If any parts are missing, do not operate your saw until the missing parts are replaced. Failure to do so could result in possible serious personal injury.

ACCESSORIES

The following recommended accessories are currently available at Sears Retail Stores.

ITEM NO.	BLADE TYPES	LENGTH IN.	TEETH PER IN.
28900	For fast smooth cuts in woods, masonite, plastics, hard composition board and all plunge cutting. Keyhole blade shape permits cutting in hard to reach areas.	6	6
28901	For fast rough cuts in green or fibrous woods 1 in. or thicker, for notching timber or joists, and for fast roughing-in.	9	3
28904	High speed steel blade for cutting ferrous metals less than 1/8 in. thick and for cutting tubing or pipe with a 1/8 in. thick wall section or less.	4	24
28984	Designed for cutting flush to a wall or along a floor. For fast smooth cuts in woods, plastics, and hard composition board.	6	7
28902	For fast, smooth, deep cuts through thick wood, plastic, composition board, and hardboard.	12	6
28903	For rough cuts in wood.	6	14



WARNING: The use of attachments or accessories not listed above might be hazardous.

BLADE SELECTION

To obtain the best performance from your saw it is important to select a specific blade for the particular application and type of material you wish to cut. By doing this you will get a smoother faster cut and prolong blade life. Replacement blades for this saw are available from your nearest Sears Retail Store.

FEATURES

KNOW YOUR ELECTRONIC RECIPROCATING SAW

See Figure 1.

Before attempting to use your saw, familiarize yourself with all operating features and safety requirements.

SWITCH

To turn your reciprocating saw ON, depress the switch trigger. Release switch trigger to turn your saw OFF.

ELECTRICAL CONNECTION

Your saw has a precision built electric motor. It should be connected to a power supply that is 120 volts, 60 Hz, AC only (normal household current). Do not operate this tool on direct current (DC). A substantial voltage drop will cause a loss of power and the motor will overheat. If your saw does not operate when plugged into an outlet, double-check the power supply.

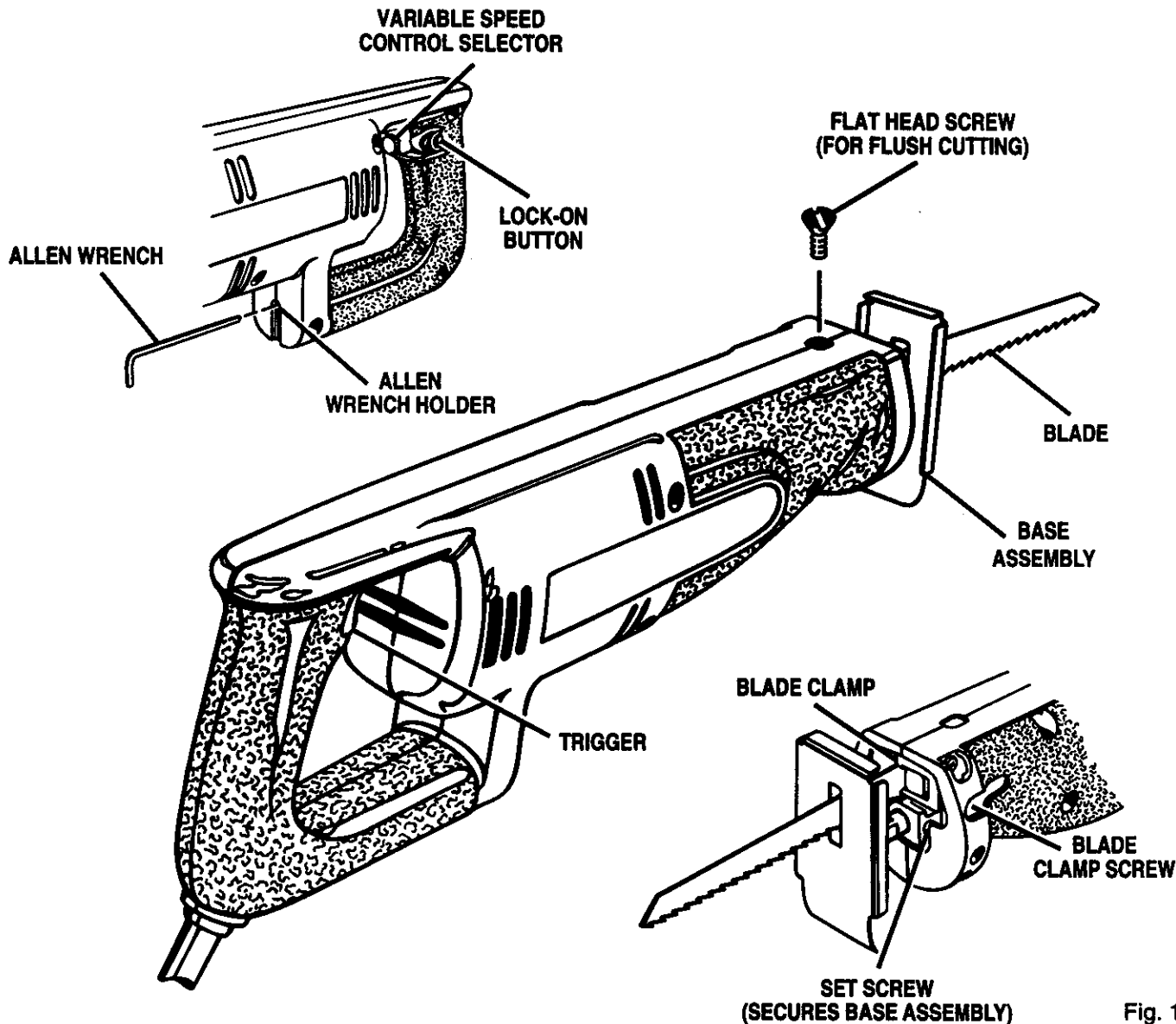

Fig. 1

WARNING: Do not allow familiarity with your saw to make you careless. Remember that a careless fraction of a second is sufficient to inflict severe injury.

ALLEN WRENCH HOLDER

See Figure 1.

A convenient feature on your saw is an Allen wrench holder. It is located on the bottom portion of your saw's handle. It is convenient for storing Allen wrench when not in use.

FEATURES

⚠ WARNING: Always wear safety goggles or safety glasses with side shields when operating your electronic reciprocating saw. Failure to do so could result in foreign objects being thrown into your eyes resulting in possible serious injury.

LOCK-ON BUTTON

See Figure 2.

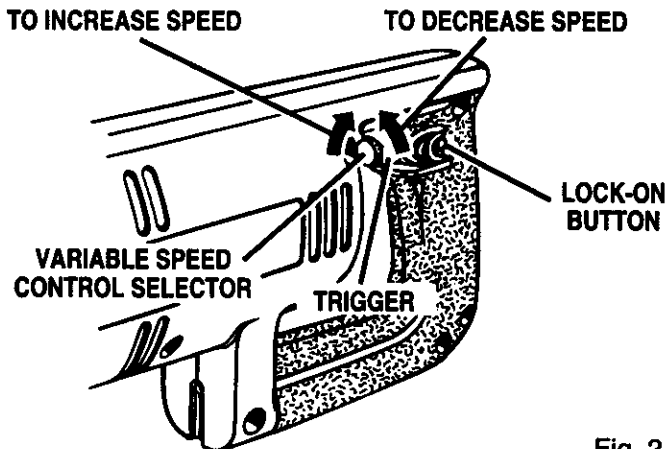

Fig. 2

Your saw is equipped with a lock-on feature, which is convenient when continuous cutting for extended periods of time is required. To lock-on, depress the switch trigger, push in and hold the lock-on button located on the side of the handle, then release switch trigger. Release lock-on button and your saw will continue running.

To release the lock, depress the switch trigger and release it. **Do not** lock the trigger on heavy jobs where your saw may have to be stopped quickly.

⚠ WARNING: When using your saw with the switch lock-on, keep your finger on the trigger and be prepared to disengage the lock-on feature at all times. Failure to do so could result in loss of control leading to possible serious injury.

If you have the lock-on feature engaged during use and your saw becomes disconnected from power supply, disengage the lock-on feature immediately.

⚠ WARNING: Before connecting your saw to power supply source, always check to be sure it is not in "lock-on position" (depress and release switch trigger). Failure to do so could result in accidental starting of saw resulting in possible serious injury. Also, do not lock the trigger on jobs where your saw may need to be stopped suddenly.

VARIABLE SPEED

See Figure 2.

Your electronic reciprocating saw has a variable speed control selector designed to allow operator control and adjustment of speed and power limits. The speed and power of your saw can be increased or decreased by rotating the variable speed control selector in the direction of the arrows shown in figure 2.

Note: Hold your saw in normal operating position and turn the variable speed control selector clockwise to increase the speed and power of your saw. Turn counterclockwise to decrease the speed and power of your saw.

If you desire to lock the switch on at a given speed, depress the switch trigger, push in and hold the lock-on button, then while holding the lock-on button pushed in release the switch trigger. Next, adjust the variable speed control selector until the desired speed is reached.

Note: If the variable speed control selector is fully turned in the counterclockwise direction (zero setting) your saw may not run.

If you desire not to use the variable speed control selector, turn it in the full clockwise direction. This will allow the speed of your saw to be fully controlled by the amount of switch trigger depression.

Avoid running your saw at low speeds for extended periods of time. Running at low speeds under constant usage may cause the motor of your saw to become overheated. If this occurs, cool your saw by running it without a load and at full speed.

⚠ WARNING: Your saw should never be connected to power supply when you are assembling parts, making adjustments, installing or removing blades, when cleaning, or when not in use. Disconnecting your saw will prevent accidental starting that could cause serious injury.

ADJUSTMENTS

TO INSTALL BLADES

See Figure 3.

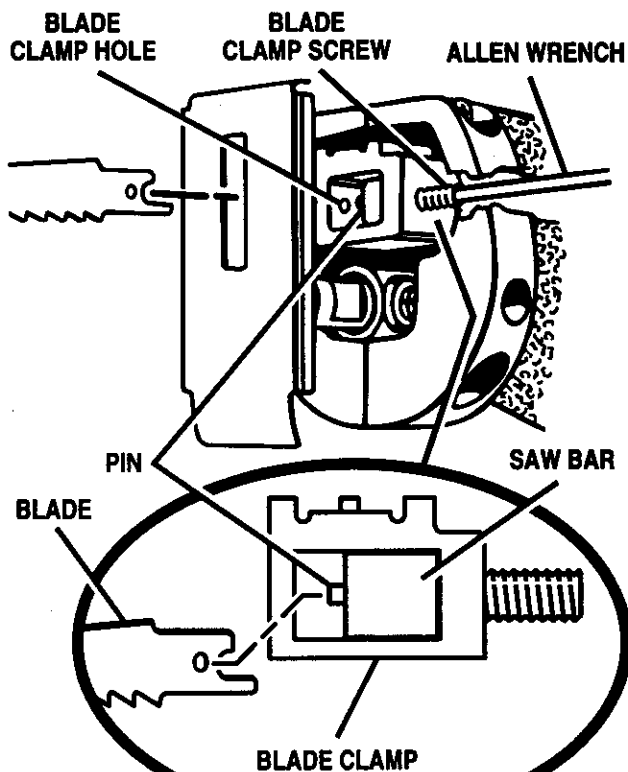

Note: It is never necessary to remove the blade clamp from the tool or the blade clamp screw from the blade clamp to change the blade.

Fig. 3

- Unplug your saw.

WARNING: Failure to unplug your saw could result in accidental starting causing possible serious injury.

- Remove the 5/32 in. Allen wrench provided with this saw from Allen wrench holder. **Note:** Allen wrench holder is located in bottom portion of saw handle. See Figure 1.
- Loosen the blade clamp screw enough to permit the saw blade to be inserted between blade clamp and saw bar.

Note: It is never necessary to remove the blade clamp from the tool or the blade clamp screw from the blade clamp to change the blade.

- Align the hole in the shank of the blade and blade clamp with the pin in the saw bar, then seat both on the pin in the saw bar. **Note:** Saw blades may be installed with the teeth directed either up or down to fit your cutting requirements.
- Tighten blade clamp screw securely.
- Remove Allen wrench and store it in allen wrench holder.

Note: There may be times when the blade clamp sticks to the saw bar and will not loosen enough to allow blades to be installed or removed. If this

happens, loosen the blade clamp screw with the Allen wrench, then tap lightly on the end of the Allen wrench with a mallet. See Figure 4.

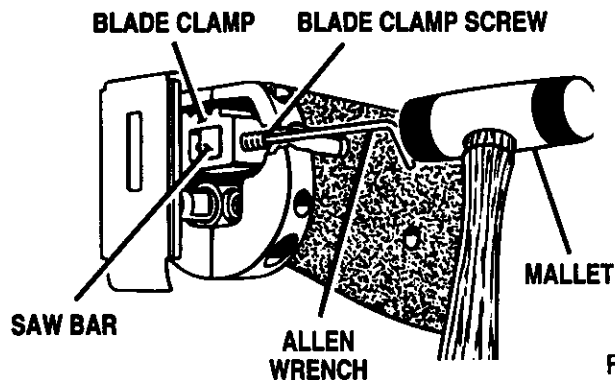

Fig. 4

BASE ASSEMBLY

See Figure 5.

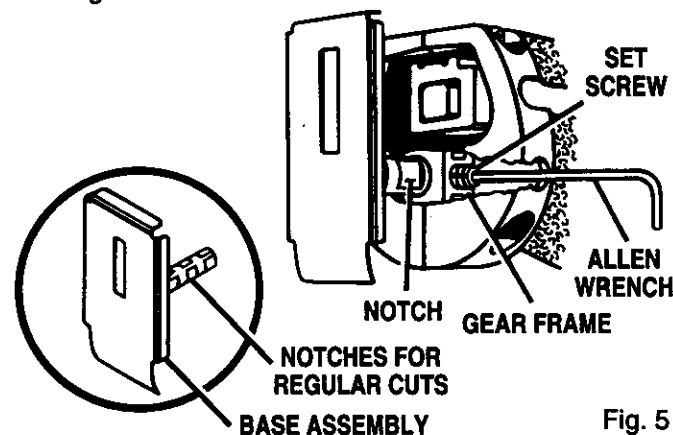

Fig. 5

The base assembly of your electronic reciprocating saw is adjustable, allowing the use of the blade teeth at different positions on the blade.

Four cutting positions are available when making cuts using regular blades. Three cutting positions are available when making cuts using flush cutting blades.

TO CHANGE POSITIONS OF BASE ASSEMBLY:

- Unplug your saw.

WARNING: Failure to unplug your saw could result in accidental starting causing possible serious injury.

- Loosen the set screw in the gear frame with the 5/32 in. Allen wrench mentioned above.
- Reposition base assembly and align in the desired notch. **Note:** When changing from cutting with regular blades to cutting with flush cutting blades, base assembly must be turned clockwise 90°. Turn counterclockwise 90° when changing from cutting with flush cutting blades to cutting with regular blades.
- Retighten set screw securely.
- Remove Allen wrench and store it in Allen wrench holder.

ADJUSTMENTS

TO INSTALL OPTIONAL FLUSH CUTTING BLADES

See Figures 6 and 7.

Flush cutting blades should be used when making close or flush cuts to walls.

- Unplug your saw.

WARNING: Failure to unplug your saw could result in accidental starting causing possible serious injury.

- Using the 5/32 in. Allen wrench provided with your saw, loosen the blade clamp screw and remove regular saw blade.
- Tighten blade clamp screw securely.
- Loosen set screw and turn base assembly clockwise 90°. See Figure 6.

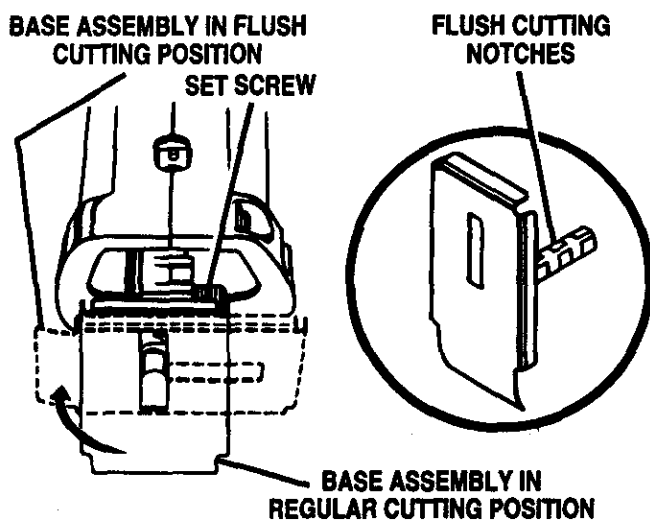

Fig. 6

- Align in desired notch, then tighten set screw securely.
- Remove Allen wrench and store it in Allen wrench holder.
- Plug your electronic reciprocating saw into power supply source.
- Depress and release the switch trigger of your saw in quick, short starts and stops until blade clamp is in its full rear position. See Figure 7.
- Unplug your saw.

WARNING: Failure to unplug your saw could result in accidental starting causing possible serious injury.

- Insert flush cutting blade on top of blade clamp as shown in figure 7.
- Align hole in blade shank with pin on blade clamp.

- Using the flat head screw provided, secure blade to saw bar assembly. See Figure 7.

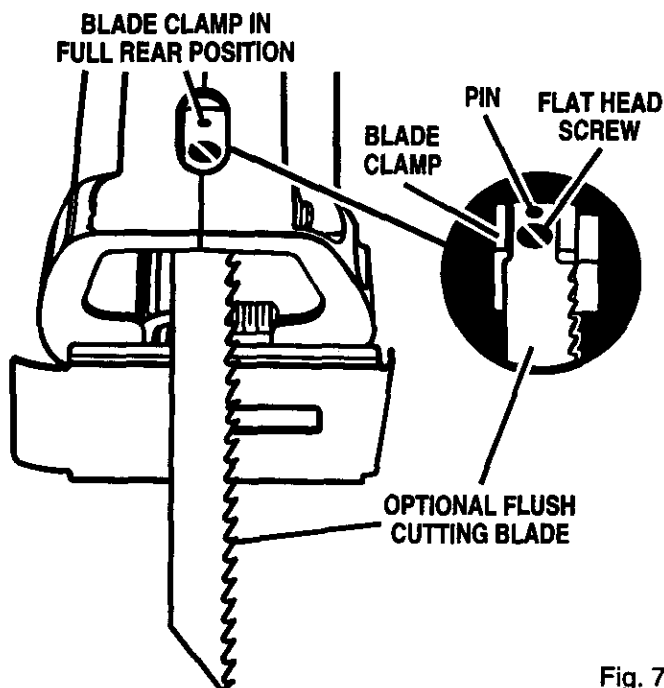

Fig. 7

- Tighten flat head screw securely.

OPERATION

GENERAL CUTTING

See Figure 8.

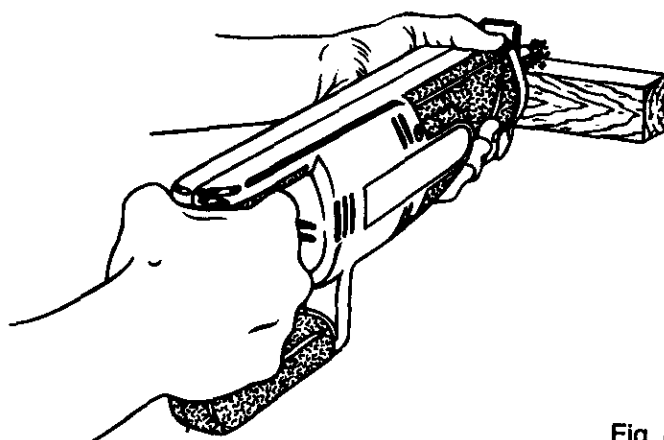

Fig. 8

Hold your saw firmly in front of and clearly away from you. Make sure saw blade is clear of any foreign material and that power cord and extension cord are out of the blade path. Be sure material to be cut is held firmly. Small work pieces should be securely clamped in a vise or with clamps to the work bench or table. Mark the line of cut clearly. Depress the trigger switch starting the cutting action, set the base assembly on the work, then move the blade into the work. **Do not force.** Use only enough pressure to keep the saw cutting. Let the blade and saw do the work.

OPERATION

PLUNGE CUTTING

See Figure 9.

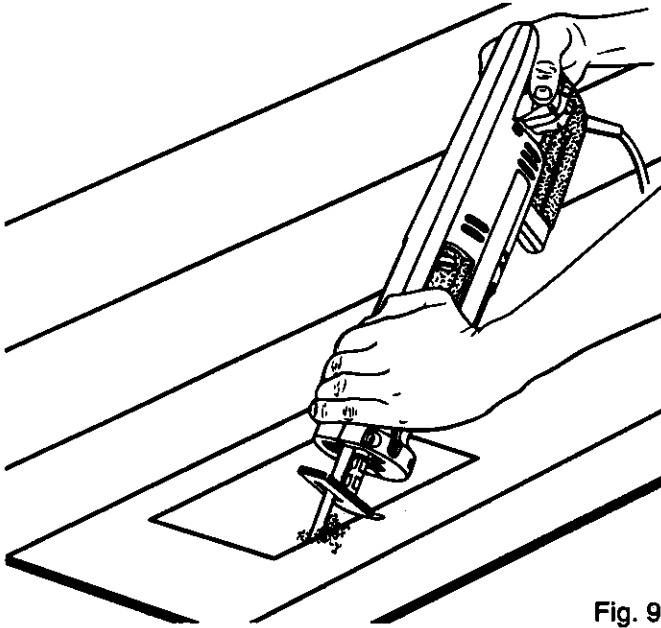

Fig. 9

Mark the line of cut clearly. Choose a convenient starting point inside the area to be cut out and place the tip of the blade over that point. Rest front edge of base assembly on work and hold firmly in position.

Note: Make sure blade does not touch work until motor reaches full speed, since this could cause loss of control resulting in serious injury. With saw blade at full cutting speed, slowly tilt saw downward until tip of blade starts cutting work. After blade penetrates work, tilt saw until blade is perpendicular to the work.

FLUSH CUTTING

See Figure 10.

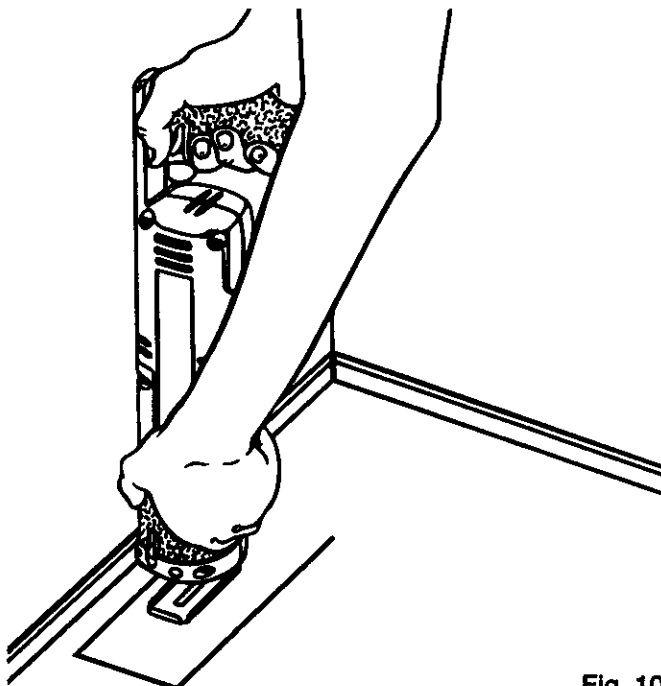

Fig. 10

Your saw has been designed with a flush cutting feature which permits cutting close to floors or walls. To fit your cutting requirements, cuts may be made in either direction by reversing the position of the blade in the blade clamp. See page 10 for instructions on installing Flush Cutting Blade.

METAL CUTTING

See Figure 11.

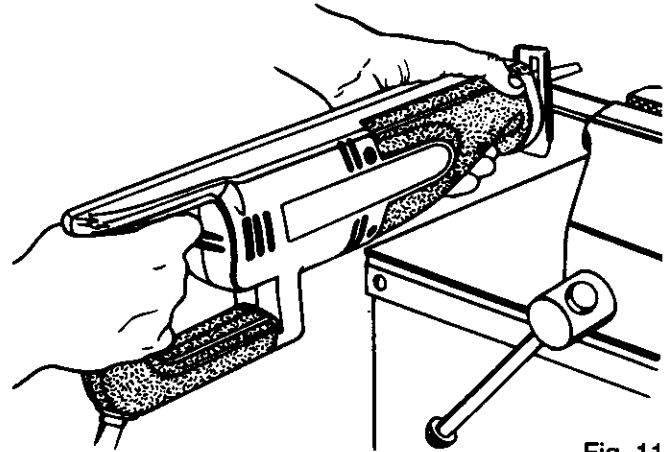

Fig. 11

Metals such as sheet steel, pipe, steel rods, aluminum, brass, and copper may be cut with your saw. Be careful not to twist or bend the saw blade. **Do not force.** We recommend cutting oil when cutting most soft metals and steel. Cutting oil will also keep blades cool, increase cutting action, and prolong blade life.

Never use gasoline since normal sparking of motor could ignite fumes. Clamp the work firmly and cut close to the clamping point to eliminate any vibration of the work being cut. When cutting conduit pipe or angle iron, clamp work in a vise if possible and cut close to the vise. To cut thin sheet material, "sandwich" the material between hardboard or plywood and clamp the layers to eliminate vibration and material tearing.

POWER CORD

See Figure 12.

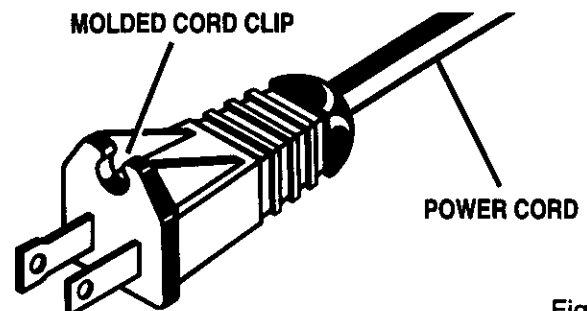

Fig. 12

Your electronic reciprocating saw has an extra-long power cord that stays soft and flexible in cold weather. The plug design is shaped so that it won't snag on your work during use. A molded cord clip on the plug makes cord storage easier.

MAINTENANCE

⚠ WARNING: When servicing, use only identical Craftsman replacement parts. Use of any other part may create a hazard or cause product damage.

GENERAL

Only the parts shown on parts list, page 13, are intended to be repaired or replaced by the customer. All other parts represent an important part of the double insulation system and should be serviced only by a qualified Sears service technician.

Avoid using solvents when cleaning plastic parts. Most plastics are susceptible to damage from various types of commercial solvents and may be damaged by their use. Use clean cloths to remove dirt, carbon dust, etc.

⚠ WARNING: Do not at any time let brake fluids, gasoline, petroleum-based products, penetrating oils, etc. come in contact with plastic parts. They contain chemicals that can damage, weaken or destroy plastic.

It has been found that electric tools are subject to accelerated wear and possible premature failure when they are used on fiberglass boats, sports cars, wallboard, spackling compounds, or plaster. The chips and grindings from these materials are highly abrasive to electric tool parts such as bearings, brushes, commutators, etc. Consequently, it is not recommended that this tool be used for extended work on any fiberglass material, wallboard, spackling compounds, or plaster. During any use on these materials it is extremely important that the tool is cleaned frequently by blowing with an air jet.

LUBRICATION

All of the bearings in this tool are lubricated with a sufficient amount of high grade lubricant for the life of the unit under normal operating conditions. Therefore, no further lubrication is required.

EXTENSION CORDS

The use of any extension cord will cause some loss of power. To keep the loss to a minimum and to prevent tool overheating, use an extension cord that is heavy enough to carry the current the tool will draw.

A wire gage size (A.W.G.) of at least 16 is recommended for an extension cord 75 feet or less in length. A wire gage (A.W.G.) of at least 14 is recommended for an extension cord 75 - 100 feet in length. When working outdoors, use an extension cord that is suitable for outdoor use. The cord's jacket will be marked **WA**.

⚠ CAUTION: Keep extension cords away from the cutting area and position the cord so that it will not get caught on lumber, tools, etc., during cutting operation.

⚠ WARNING: Check extension cords before each use. If damaged replace immediately. Never use tool with a damaged cord since touching the damaged area could cause electrical shock resulting in serious injury.

Extension cords suitable for use with your saw are available at your nearest Sears Retail Store.

⚠ WARNING: Always wear safety goggles or safety glasses with side shields during power tool operation or when blowing dust. If operation is dusty, also wear a dust mask.

CRAFTSMAN RECIPROCATING SAW — MODEL NUMBERS 315.171071 / 315.171081

The model number will be found on a plate attached to the motor housing. Always mention the model number in all correspondence regarding your **RECIPROCATING SAW** or when ordering repair parts.

SEE BACK PAGE FOR PARTS ORDERING INSTRUCTIONS

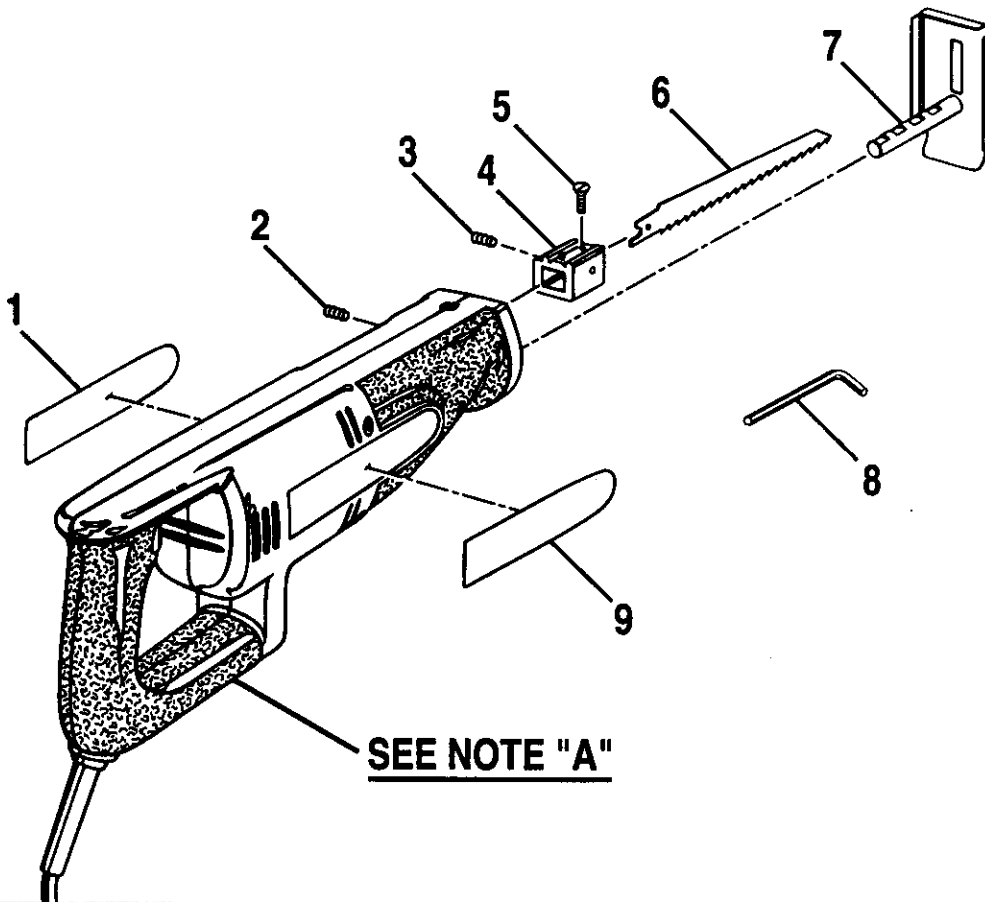

PARTS LIST

Key No.	Part Number	Description	Quan.
1	975161-001	Logo Plate	1
2	998743-001	* Set Screw (#5/16-24 x 3/4 in. Hex Socket)	1
3	989207-001	* Set Screw (#5/16-24 x 3/4 in. Flat Point)	1
4	981185-001	Blade Clamp Assembly (Includes Key No. 3)	1
5	623934-002	Flush Cutting Blade Screw (Used With Flush Cutting Blade Only)	1
6	***	Saw Blade	1
7	998277-004	Base Assembly	1
8	820193-006	* 5/32 in. Allen Wrench (Item No. 9-28173)	1
9	981060-001	Data Plate (Model No. 315.171071)	1
	981058-001	Data Plate (Model No. 315.171081)	1
10	975166-000	Carrying Case (Model No. 315.171071) – Not Shown	1
	975166-000	Optional Carrying Case (Model No. 315.171081) – Not Shown	1
	972000-636	Owners manual	

NOTE: "A"— The assembly shown represents an important part of the Double Insulated System. To avoid the possibility of alteration or damage to the system, service should be performed by your nearest Sears Repair Center. Contact your nearest Sears Retail Store for Service Center information.

* Standard Hardware Item — May Be Purchased Locally.
 *** Complete Assortment Available At Your Nearest Sears Retail Store.

**In U.S.A. or Canada
for in-home major brand repair service:**

Call 24 hours a day, 7 days a week

1-800-4-MY-HOMESM (1-800-469-4663)

Para pedir servicio de reparación a domicilio – 1-800-676-5811

Au Canada pour tout le service ou les pièces – 1-800-469 4663

For the repair or replacement parts you need:

Call 6 a.m. – 11 p.m. CST, 7 days a week

Parts DirectSM

1-800-366-PART (1-800-366-7278)

Para ordenar piezas con entrega a domicilio – 1-800-659-7084

For the location of a Sears Service Center in your area:

Call 24 hours a day, 7 days a week

1-800-488-1222

To purchase or inquire about a Sears Maintenance Agreement:

Call 7 a.m. – 5 p.m. CST, Monday – Saturday

1-800-827-6655

