

SEARS

operator's manual

MODEL NO. 143.994024
4.0 RESERVE POWER
10 INCH CUBIC (163 cc)
DISPLACEMENT

SOLID STATE IGNITION

CAUTION:

Read RULES for
Safe OPERATION
and INSTRUCTIONS
Carefully

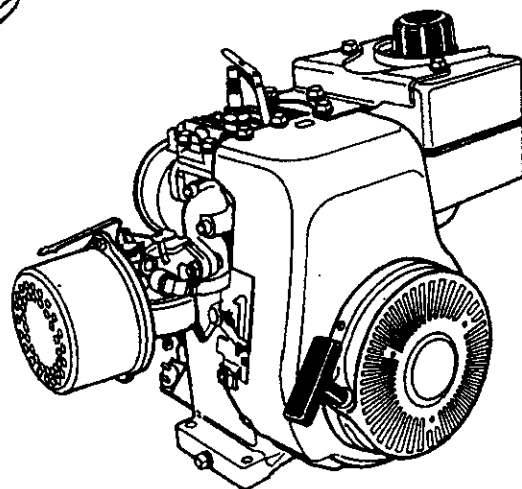
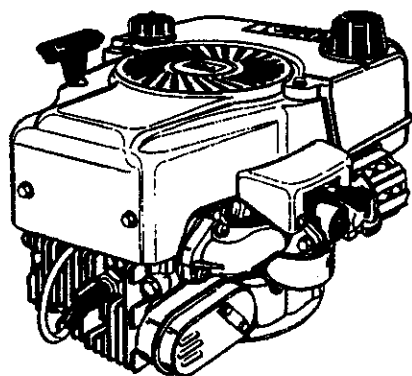

ENGINE

- Operating
- Maintenance
- Repair Parts



California Proposition 65 **WARNING:** The engine exhaust from this product contains chemicals known to the State of California to cause cancer, birth defects or other reproductive harm.

Sold by SEARS, ROEBUCK AND CO., CHICAGO, IL 60684 U.S.A.
and SEARS CANADA, INC., TORONTO, ONTARIO, CANADA

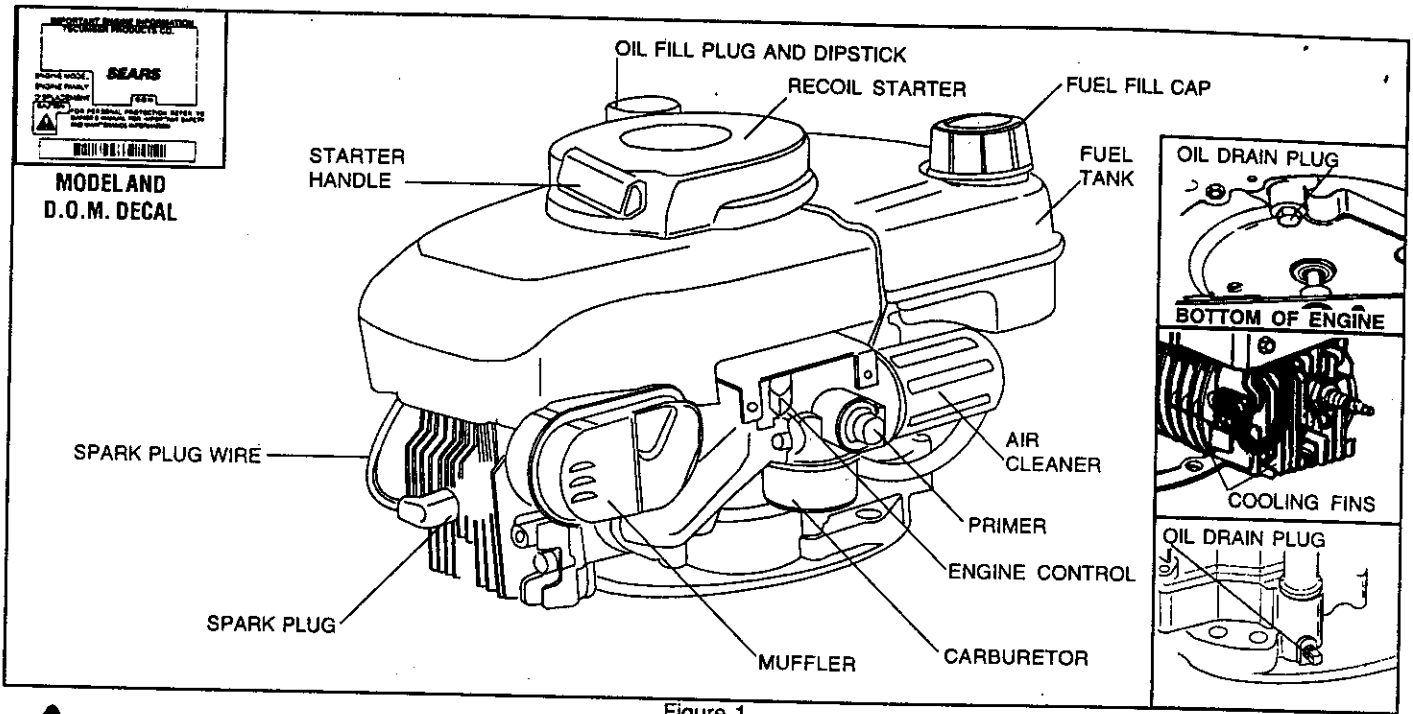

Figure 1



THIS SYMBOL POINTS OUT IMPORTANT SAFETY INSTRUCTIONS WHICH IF NOT FOLLOWED COULD ENDANGER THE PERSONAL SAFETY AND/OR PROPERTY OF YOURSELF AND OTHERS. READ AND FOLLOW ALL INSTRUCTIONS IN THIS MANUAL AND ANY PROVIDED WITH THE EQUIPMENT ON WHICH THIS ENGINE IS USED BEFORE ATTEMPTING TO OPERATING.



THESE SYMBOLS MAY APPEAR ON THE ENGINE:



FAST



SLOW



STOP



OFF



CHOKE



FULL

ENGINES WHICH ARE CERTIFIED TO COMPLY WITH CALIFORNIA AND U.S. EPA EMISSION REGULATIONS FOR ULGE ENGINES: Are certified to operate on regular unleaded gasoline. Include the following emission control system(s): Em, TWC (if so equipped); Do not include any user adjustable features - therefore no other adjustments are needed.

OIL & FUEL RECOMMENDATIONS

TO OPERATE ENGINE, YOU WILL NEED THE FOLLOWING:

① A CLEAN, HIGH QUALITY, DETERGENT OIL.

Be sure original container is marked:
A.P.I. service "SF" - "SJ".

FOR SUMMER (ABOVE 32°F; 0°C) USE SAE 30 OIL.

Using multigrade oil will increase oil consumption.

FOR WINTER (BELOW 32°F; 0°C) USE SAE 5W30 OIL.

(SAE 10W is an acceptable substitute.)

DO NOT USE SAE 10W40 OIL.

OIL SUMP CAPACITY: 21 ounces (1-1/4 U.S. pints)
.62 liter

② A FRESH, CLEAN, UNLEADED REGULAR, UNLEADED PREMIUM, OR REFORMULATED AUTOMOTIVE GASOLINE ONLY. DO NOT USE LEADED GASOLINE.

NOTE: DO NOT USE GASOLINE CONTAINING METHANOL (WOOD ALCOHOL). Gasoline containing up to 10% ethanol or grain alcohol ("Gasohol"), or up to 15% MTBE (Methyl Tertiary Butyl Ether), may be used but requires special care when engine is unused for extended periods.

See "STORAGE" instructions of Page 4.

NOTE: Use clean oil and fuel and store in approved, clean covered containers. Use clean fill funnels. Never use "stale" gasoline left over from last season or stored for long periods.

IMPORTANT

KEEP THIS MANUAL HANDY AT ALL TIMES FOR FUTURE REFERENCE. READ IT CAREFULLY AND FAMILIARIZE YOURSELF WITH THE OPERATING, MAINTENANCE AND SAFETY INSTRUCTIONS. THIS MANUAL ALSO CONTAINS A COMPLETE PARTS LISTING.

BEFORE STARTING

① READ ALL INSTRUCTIONS PROVIDED WITH THE EQUIPMENT ON WHICH THIS ENGINE IS USED.

② **CHECK OIL LEVEL:**

IMPORTANT: NEVER RUN ENGINE UNLESS OIL LEVEL IS BETWEEN "FULL" AND "ADD" MARKS ON DIPSTICK.

CHECK OIL LEVEL OFTEN DURING ENGINE BREAK-IN.

NEVER RUN ENGINE UNLESS OIL FILL PLUG IS TIGHTENED SECURELY INTO OIL FILL HOLE.

- A. POSITION EQUIPMENT SO ENGINE IS LEVEL.
- B. Clean area around oil fill plug (see Figure 1).
- C. Remove oil fill plug and dipstick.
- D. Wipe dipstick clean, insert it into oil fill hole and tighten securely.
- E. Remove oil fill plug and check oil level. If level is not up to "FULL" mark on dipstick, add recommended oil, until it is. **POUR SLOWLY.** Wipe dipstick clean each time oil level is checked. **DO NOT FILL ABOVE "FULL" MARK ON DIPSTICK.**
- F. Replace oil fill plug and tighten securely.

See "MAINTENANCE" section for any future oil level and oil change instructions (see Page 2).

BEFORE STARTING (Continued)

- ③ **FILL FUEL TANK** with gasoline as specified in the preceding "OIL & FUEL RECOMMENDATIONS" item 2.

NEVER MIX OIL WITH GASOLINE

Never use "stale" gasoline left over from last season or stored for long periods.

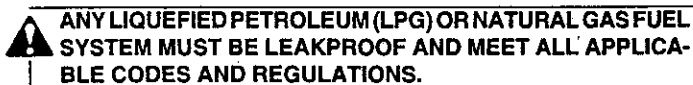
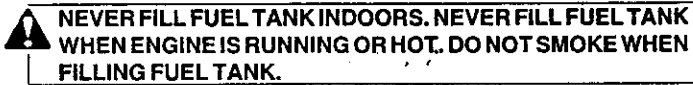

- ④ **CHECK THE FOLLOWING:**



- B. Be sure spark plug wire is attached to spark plug (see Figure 1).

STARTING

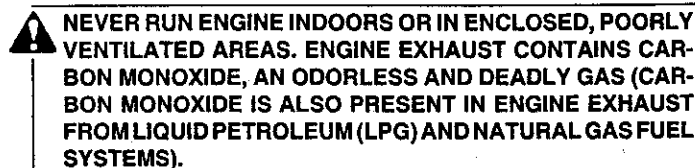

- ① Move ENGINE CONTROL (see Figure 1) to HI Position.

② START ENGINE

- A. The carburetor on your engine has been completely adjusted at the factory. When starting a cold engine, push red primer bulb **firmly with your thumb 5 times**, allowing primer bulb to return completely to original position between pushes. Repeat the above for each starter operation as necessary.

NOTE: DO NOT USE PRIMER TO RESTART A WARM ENGINE AFTER A SHORT SHUTDOWN.

- B. Grasp starter handle (see Figure 2) and pull rope out, slowly, until it pulls slightly harder. Let rope rewind slowly. Then pull rope with a rapid full arm stroke. Let rope rewind **SLOWLY**. Do not let starter handle snap back against rope guide (see Figure 2).

- C. Repeat instruction B if necessary, until engine starts.
NOTE: If engine does not start, repeat instructions A, B and C until it starts.

ENGINE SPEED: Engine speed is controlled by the ENGINE CONTROL (see Figure 1).

ENGINE CONTROL should be in HI position for high grass conditions and for most efficient bagging in heavy grass conditions, and in LOW position for light grass, trimming and for fuel economy.

STOPPING

- ① Move ENGINE CONTROL (see Figure 1) to STOP.

② AFTER ENGINE IS STOPPED:

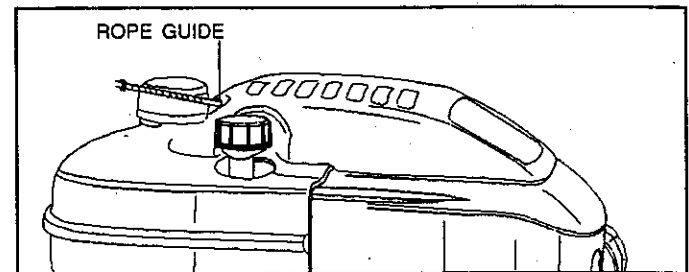
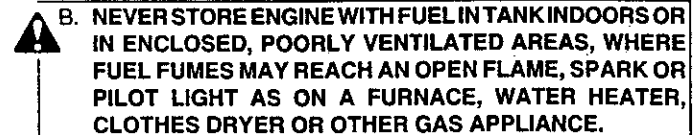

Figure 2

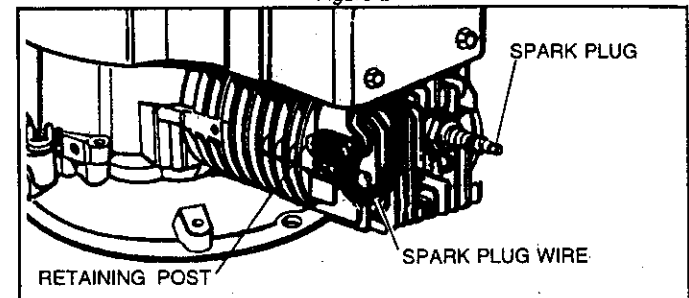

Figure 3

MAINTENANCE



① CHECK OIL LEVEL:

Check oil level every five (5) operating hours or each time engine is used. See "② CHECK OIL LEVEL" in "BEFORE STARTING" on Page 1.

② CHANGE OIL:

Change oil after first two (2) operating hours and every 25 operating hours thereafter, more often if operated in extremely dusty or dirty conditions. Change oil while engine is still warm from recent running.



- B. Position equipment so engine oil drain plug is lowest point on engine.
C. Remove oil drain plug and oil fill plug to drain oil (see Figure 1).
D. Replace oil drain plug and tighten securely.
E. Fill oil sump with recommended oil. See "OIL & FUEL RECOMMENDATIONS" and "CHECK OIL LEVEL" on Page 1.
F. Replace oil fill plug and tighten securely.
G. Connect spark plug wire to spark plug.
H. Wipe up any spilled oil and/or gasoline.

NOTE: If it is difficult to reach the oil drain plug, drain fuel. Remove oil fill plug and tip mower on its side. Drain oil into a suitable container.

MAINTENANCE (Continued)

③ AIR CLEANER (see Figure 4):

NEVER RUN ENGINE WITHOUT COMPLETE AIR CLEANER INSTALLED ON ENGINE.

Replace filter once a year or more often if used in extremely dusty or dirty conditions.

DO NOT ATTEMPT TO CLEAN OR OIL FILTER.

Replacement filters are available at any Sears Roebuck and Co. (or Sears Canada, Inc.) Service Center. To install new filter, proceed as follows:

- Turn cover to the left (counterclockwise) and remove it and filter from flange. Discard filter.
- Clean cover and flange thoroughly.
- Insert new filter into cover.
- Position cover and filter against flange with tab on cover inserted into lower left corner of slot in flange.
- Push cover firmly against flange and turn it to the right (clockwise) as far as it will go. Be sure retainers are locked around flange.

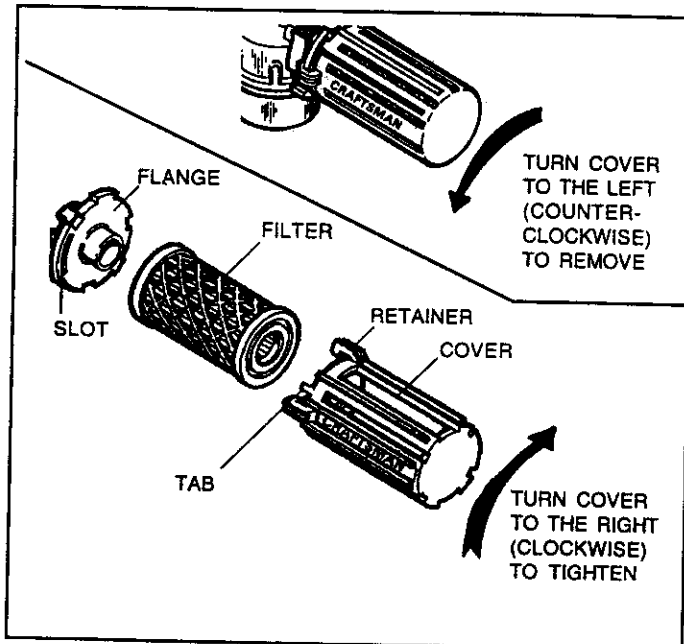

Figure 4

MAINTENANCE (Continued)

④ SPARK PLUG (see Figure 5):

This spark ignition system meets all requirements of the Canadian Interference-Causing Equipment Regulations. This engine complies with all current Australian and New Zealand limitations regarding electromagnetic interference.

Check spark plug yearly or every 100 operating hours.

- Clean area around spark plug.
- Remove and inspect spark plug.
- Replace spark plug if electrodes are pitted, burned or porcelain is cracked. For replacement use Champion RJ-19LM or equivalent.

NOTE: A resistor spark plug must be used for replacement.

- Check electrodes gap with wire feeler gauge and set gap at .030 if necessary.
- Install spark plug, tighten securely.

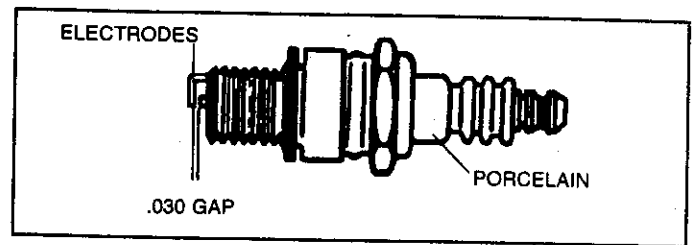

Figure 5

⑤ COOLING SYSTEM (see Figure 1):

IMPORTANT: Frequently remove any grass clippings, dirt and debris from cooling fins, air intake screen and levers and linkage (see Figure 1). This will help ensure adequate cooling and correct engine speed.

⑥

⚠ CHECK ENGINE AND EQUIPMENT OFTEN FOR LOOSE NUTS, BOLTS AND ATTACHMENTS, AND KEEP THESE ITEMS TIGHTENED.

ADJUSTMENTS

DO NOT MAKE UNNECESSARY ADJUSTMENTS. FACTORY SETTINGS ARE SATISFACTORY FOR MOST APPLICATIONS AND CONDITIONS. IF ADJUSTMENTS ARE NEEDED, PROCEED AS FOLLOWS:

① CARBURETOR

If you think your carburetor needs adjusting, see your nearest SEARS, ROEBUCK AND CO. (OR SEARS CANADA, INC.) SERVICE CENTER. Engine performance should not be affected at altitudes up to 7,000 feet. For operation at higher elevations, contact your nearest SEARS, ROEBUCK AND CO. (OR SEARS CANADA, INC.) SERVICE CENTER.

② ENGINE SPEED

⚠ NEVER TAMPER WITH ENGINE GOVERNOR WHICH IS FACTORY SET FOR PROPER ENGINE SPEED. OVERSPEEDING ENGINE ABOVE FACTORY HIGH SPEED SETTING CAN BE DANGEROUS.

CHANGING OF ENGINE-GOVERNED SPEED WILL VOID ENGINE WARRANTY.

STORAGE

⚠ NEVER STORE ENGINE WITH FUEL IN TANK INDOORS OR IN ENCLOSED, POORLY VENTILATED AREAS, WHERE FUEL FUMES MAY REACH AN OPEN FLAME, SPARK OR PILOT LIGHT AS ON A FURNACE, WATER HEATER, CLOTHES DRYER OR OTHER GAS APPLIANCE.

IF ENGINE IS TO BE UNUSED FOR 30 DAYS OR MORE, PREPARE AS FOLLOWS:

① DRAIN FUEL SYSTEM:

A. Remove all gasoline from carburetor and fuel tank to prevent gum deposits from forming on these parts and causing possible malfunction of engine.

⚠ DRAIN FUEL INTO APPROVED CONTAINER OUTDOORS, AWAY FROM OPEN FLAME. BE SURE ENGINE IS COOL. DO NOT SMOKE.

B. Run engine until fuel tank is empty and engine stops due to lack of fuel.

NOTE: Fuel stabilizer (such as STA-BIL) is an acceptable alternative in minimizing the formation of fuel gum deposits during storage. Add stabilizer to gasoline in fuel tank or storage container. Always follow mix ratio found on stabilizer container. Run engine at least 10 minutes after adding stabilizer to allow it to reach carburetor.

STORAGE (Continued)

② CHANGE OIL:

Change oil if it has not been changed in the last three (3) months. See "CHANGE OIL" instructions in "MAINTENANCE" section.

③ OIL CYLINDER BORE:

- A. Remove spark plug. Squirt one (1) oz. (30 ml) of clean engine oil into spark plug hole.
- B. Cover spark plug hole with a rag.
- C. Crank engine over, slowly, several times.

⚠ AVOID SPRAY FROM SPARK PLUG HOLE WHEN CRANKING ENGINE OVER SLOWLY.

D. Install spark plug. Do not connect spark plug wire.

④ CLEAN ENGINE:

Remove any clippings, dirt, or chaff from exterior of engine.

GENERAL

Just as your automobile needs professional mechanical maintenance from time to time, so does your Craftsman engine. Replacement of the spark plug and air cleaner is made necessary by NORMAL use. Professional Air-Cooled Engine Service is as close as your nearest Sears Roebuck and Co. (or Sears Canada, Inc.) Service Center.

A yearly check-up or tune-up by Sears is a good idea to avoid breakdowns or delay... do it at the end of the season, then you're ready for the next. We even prepare it for storage for you.

TROUBLESHOOTING

**THE FOLLOWING MAY HELP AVOID A DELAY IN YOUR WORK OR
SAVE THE EXPENSE OF A SERVICE CALL.**

ENGINE FAILS TO START OR STARTS WITH DIFFICULTY	
CAUSE	REMEDY
Controls not in start position.	Move ENGINE CONTROL or equipment control to "HI" or START position. See "STARTING" instructions in this manual.
Spark plug wire disconnected from spark plug.	Connect SPARK PLUG WIRE to SPARK PLUG.
Spark plug fouled.	Remove SPARK PLUG and clean it. See "SPARK PLUG" instructions in "MAINTENANCE" section in this manual.
Spark plug porcelain cracked.	Install new spark plug.
Insufficient fuel.	Fill FUEL TANK per "BEFORE STARTING" instructions.
Water or dirt in fuel.	Drain FUEL TANK and re-fill with clean, fresh gasoline. See "BEFORE STARTING" instructions in this manual.
Improper carburetor adjustment	Adjust carburetor (if applicable). See "ADJUSTMENTS" section in this manual.
ENGINE LACKS POWER	
CAUSE	REMEDY
Dirty air cleaner.	Replace or clean air cleaner per "AIR CLEANER" instructions in "MAINTENANCE" section in this manual.
Improper carburetor adjustment.	Adjust carburetor (if applicable). See "ADJUSTMENTS" section in this manual.
Lack of lubricaiton.	Fill oil sump to proper level. See "BEFORE STARTING" instructions section in this manual.
ENGINE MISSES UNDER LOAD	
CAUSE	REMEDY
Spark plug fouled.	Remove SPARK PLUG and clean it. See "SPARK PLUG" instructions in "MAINTENANCE" section in this manual.
Spark plug porcelain cracked.	Install new SPARK PLUG.
Improper spark plug gap.	Regap SPARK PLUG electrodes. See "SPARK PLUG" instructions in "MAINTENANCE" section in this manual.
Improper carburetor adjustment	Adjust carburetor (if applicable). See "ADJUSTMENTS" section in this manual.

SEARS, ROEBUCK AND CO.

Federal and California Emission Control Systems Limited Warranty Utility and Lawn and Garden Engines

CALIFORNIA & US EPA EMISSION CONTROL WARRANTY STATEMENT

The U. S. Environmental Protection Agency ("EPA"), the California Air Resources Board ("CARB") and Sears, Roebuck and Co. are pleased to explain the Federal and California Emission Control Systems Warranty on your new utility or lawn and garden equipment engine. In California, new 1995 and later utility and lawn and garden equipment engines must be designed, built and equipped to meet the State's stringent anti-smog standards. In other states, new 1997 and later model year engines must be designed, built and equipped, at the time of sale, to meet the U.S. EPA regulations for small non-road engines. Sears, Roebuck and Co. will warrant the emission control system on your utility or lawn and garden equipment engine for the periods of time listed below, provided there has been no abuse, neglect, unapproved modification, or improper maintenance of your utility or lawn and garden equipment engine.

Your emission control system may include parts such as the carburetor, ignition system and exhaust system. Also included may be the compression release system and other emission-related assemblies.

Where a warrantable condition exists, Sears, Roebuck and Co. will repair your utility or lawn and garden equipment engine at no cost to you for diagnosis, parts and labor.

MANUFACTURER'S EMISSION CONTROL SYSTEM WARRANTY COVERAGE

Emission control systems on 1995 and later model year California utility and lawn and garden equipment engines are warranted for two years as hereinafter noted. In other states, 1997 and later model year engines are also warranted for two years. If, during such warranty period, any emission-related part on your engine is defective in materials or workmanship, the part will be repaired or replaced by Sears, Roebuck and Co.

OWNER'S WARRANTY RESPONSIBILITIES

As the utility or lawn and garden equipment engine owner, you are responsible for the performance of the required maintenance listed in your Owner's Manual, but Sears, Roebuck and Co. will not deny warranty solely due to the lack of receipts or for your failure to provide written evidence of the performance of all scheduled maintenance.

As the utility or lawn and garden equipment engine owner, you should, however, be aware that Sears, Roebuck and Co. may deny you warranty coverage if your utility or lawn and garden equipment or a part thereof has failed due to abuse, neglect, improper maintenance or unapproved modifications.

You are responsible for presenting your utility or lawn and garden equipment engine to a Sears, Roebuck and Co. Authorized Service Outlet as soon as a problem exists. The warranty repairs should be completed in a reasonable amount of time, not to exceed 30 days.

Warranty service can be arranged by contacting either a Sears, Roebuck and Co. Authorized Service Outlet, or by contacting Sears, Roebuck and Co. at 1-800-473-7247.

IMPORTANT NOTE

This warranty statement explains your rights and obligations under the Emission Control System Warranty ("ECS Warranty") which is provided to you by Sears, Roebuck and Co. pursuant to California law. See also the Sears, Roebuck and Co. Limited Warranties for Sears, Roebuck and Co. which is enclosed therewith on a separate sheet and also is provided to you by Sears, Roebuck and Co. The ECS Warranty applies only to the emission control system of your new engine. To the extent that there is any conflict in terms between the ECS Warranty and the Sears, Roebuck and Co. Warranty, the ECS Warranty shall apply except in any circumstances in which the Sears, Roebuck and Co. Warranty may provide a longer warranty period. Both the ECS Warranty and the Sears, Roebuck and Co. Warranty describe important rights and obligations with respect to your new engine.

Warranty service can only be performed by a Sears, Roebuck and Co. Authorized Service Outlet. At the time of requesting warranty service, evidence must be presented of the date of sale to the original purchaser. The purchaser shall pay any charges for making service calls and/or for transporting the products to and from the place where the inspection and/or warranty work is performed. The purchaser shall be responsible for any damage or loss incurred in connection with the transportation of any engine or any part(s) thereof submitted for inspection and/or warranty work.

If you have any questions regarding your warranty rights and responsibilities, you should contact Sears, Roebuck and Co. at 1-800-473-7247.

EMISSION CONTROL SYSTEM WARRANTY

Emission Control System Warranty ("ECS Warranty") for 1995 and later model year California utility and lawn and garden equipment engines (for other states, 1997 and later model year engines):

A. APPLICABILITY: This warranty shall apply to 1995 and later model year California utility and lawn and garden equipment engines (for other states, 1997 and later model year engines). The ECS Warranty Period shall begin on the date the new engine or equipment is delivered to its original, end-use purchaser, and shall continue for 24 consecutive months thereafter.

B. GENERAL EMISSIONS WARRANTY COVERAGE: Sears, Roebuck and Co. warrants to the original, end-use purchaser of the new engine or equipment and to each subsequent purchaser that each of its utility and lawn and garden equipment engines is:

1. Designed, built and equipped so as to conform with all applicable regulations adopted by the Air Resources Board pursuant to its authority in Chapters 1 and 2, Part 5, Division 26 of the Health and Safety Code, and
2. Free from defects in materials and workmanship which, at any time during the ECS Warranty Period, will cause a warranted emissions-related part to fail to be identical in all material respects to the part as described in the engine manufacturer's application for certification.

C. The ECS Warranty only pertains to emissions-related parts on your engine, as follows:

1. Any warranted, emissions-related parts which are not scheduled for replacement as required maintenance in the Owner's Manual shall be warranted for the ECS Warranty Period. If any such part fails during the ECS Warranty Period, it shall be repaired or replaced by Sears, Roebuck and Co. according to Subsection 4 below. Any such part repaired or replaced under the ECS Warranty shall be warranted for any remainder of the ECS Warranty Period.
2. Any warranted, emissions-related part which is scheduled only for regular inspection as specified in the Owner's Manual shall be warranted for the ECS Warranty Period. A statement in such written instructions to the effect of "repair or replace as necessary", shall not reduce the ECS Warranty Period. Any such part repaired or replaced under the ECS Warranty shall be warranted for the remainder of the ECS Warranty Period.
3. Any warranted, emissions-related part which is scheduled for replacement as required maintenance in the Owner's Manual, shall be warranted for the period of time prior to the first scheduled replacement point for that part. If the part fails prior to the first scheduled replacement, the part shall be repaired or replaced by Sears, Roebuck and Co. according to Subsection 4 below. Any such emissions-related part repaired or replaced under the ECS Warranty, shall be warranted for the remainder of the ECS Warranty Period prior to the first scheduled replacement point for such emissions-related part.
4. Repair or replacement of any warranted, emissions-related part under this ECS Warranty shall be performed at no charge to the owner at a Sears, Roebuck and Co. Authorized Service Outlet.
5. The owner shall not be charged for diagnostic labor which leads to the determination that a part covered by the ECS Warranty is in fact defective, provided that such diagnostic work is performed at a Sears, Roebuck and Co. Authorized Service Outlet.
6. Sears, Roebuck and Co. shall be liable for damages to other original engine components or approved modifications proximately caused by a failure under warranty of an emission-related part covered by the ECS Warranty.
7. Throughout the ECS Warranty Period, Sears, Roebuck and Co. shall maintain a supply of warranted emission-related parts sufficient to meet the expected demand for such emission-related parts.
8. Any Sears, Roebuck and Co. authorized and approved emission-related replacement part may be used in the performance of any ECS Warranty maintenance or repair and will be provided without charge to the owner. Such use shall not reduce Sears, Roebuck and Co. ECS Warranty obligations.
9. Unapproved add-on or modified parts may not be used to modify or repair a Sears, Roebuck and Co. engine. Such use voids this ECS Warranty and shall be sufficient grounds for disallowing an ECS Warranty claim. Sears, Roebuck and Co. shall not be liable hereunder for failures of any warranted parts of a Sears, Roebuck and Co. engine caused by the use of such an unapproved add-on or modified part.

EMISSION-RELATED PARTS INCLUDE THE FOLLOWING:

1. Carburetor Assembly and its Internal Components
 - a) Fuel filter
 - b) Carburetor gaskets
 - c) Intake pipe
2. Air Cleaner Assembly
 - a) Air filter element
3. Ignition System, including:
 - a) Spark plug
 - b) Ignition module
 - c) Flywheel assembly
4. Catalytic Muffler (if so equipped)
 - a) Muffler gasket (if so equipped)
 - b) Exhaust manifold (if so equipped)
5. Crankcase Breather Assembly and its Components
 - a) Breather connection tube

CRAFTSMAN 4-CYCLE ENGINE

MODEL: 143.994024

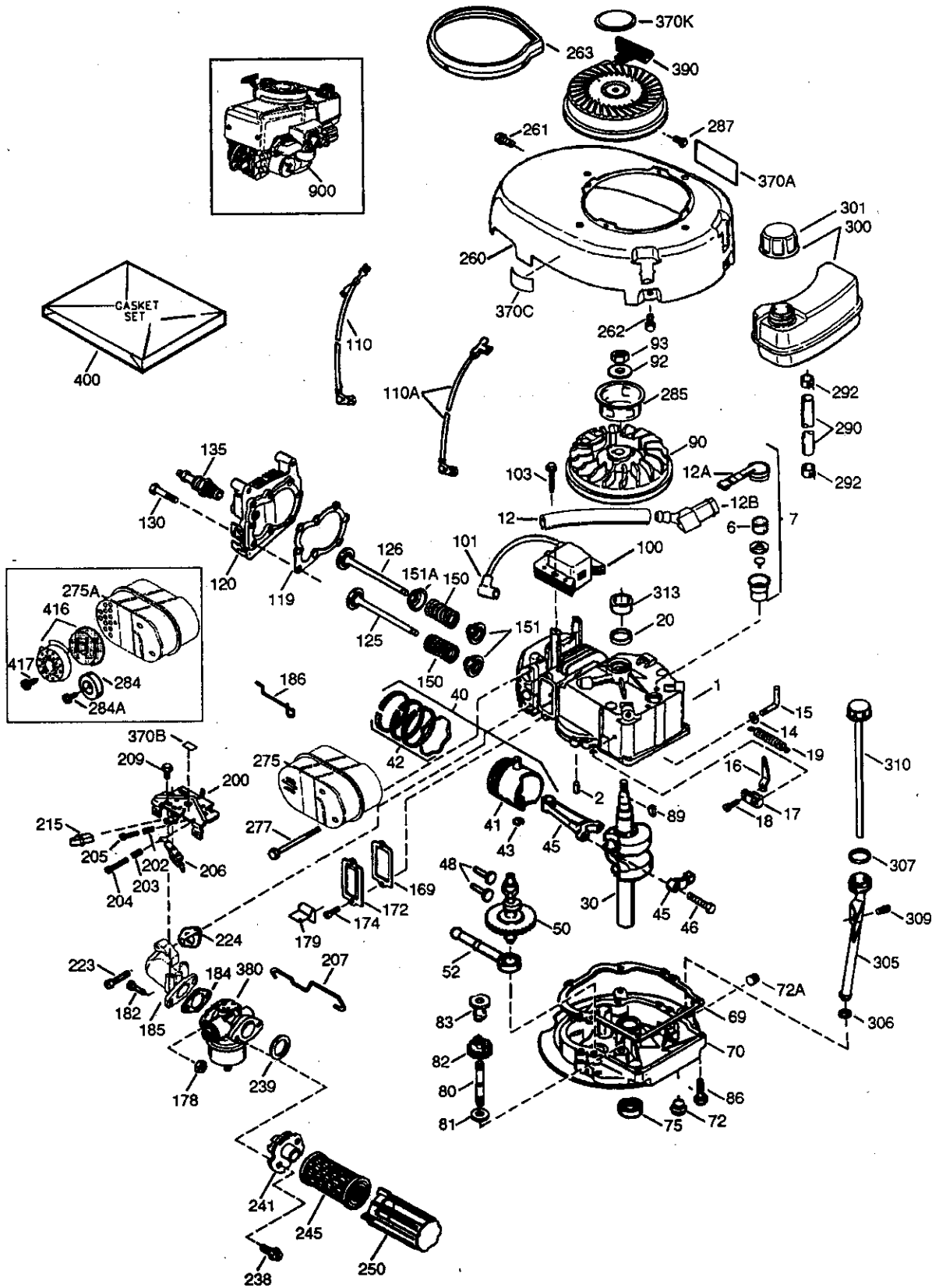

CRAFTSMAN 4-CYCLE ENGINE

MODEL: 143.994024

Ref. No.	Part No.	Part Name	Ref. No.	Part No.	Part Name
1	37280	Cylinder (Incl. 2,20 & 150)	151	31673	Valve Spring Cap
2	26727	Dowel Pin	151A	40017	Intake Valve Seal
6	33734	Breather Element	169	*36783	Valve Cover Gasket
7	36557	Breather Ass'y. (Incl. 6 & 12A)	172	36784	Valve Cover
12	36775	Breather Tube	174	30200	Screw, 10-24 x 9/16"
12A	36558	Breather Cover & Tube (Incl. 12B)	178	29752	Nut & Lock Washer, 1/4-28
12B	36694	Breather Tube Elbow	179	30593	Retainer Clip
14	28277	Washer	182	6201	Screw, 1/4-28 x 7/8"
15	30589	Governor Rod (Incl. 14)	184	*26756	Carburetor To Intake Pipe Gasket
16	34839A	Governor Lever	185	36785	Intake Pipe
17	31335	Governor Lever Clamp	186	34337	Governor Link
18	651018	Screw, Torx T-15, 8-32 x 19/64"	200	33205A	Control Bracket (Incl. 202 thru 206)
19	36281	Extension Spring	202	36482	Compression Spring
20	32600	Oil Seal	203	31342	Compression Spring
30	36833	Crankshaft	204	651029	Screw, Torx T-10, 5-40 x 7/16"
40	35544A	Piston, Pin & Ring Set (Std.)	205	651019	Screw, Torx T-10, 6-32 x 41/64"
40	35545A	Piston, Pin & Ring Set (.010" OS)	206	610973	Terminal
40	35546	Piston, Pin & Ring Set (.020" OS)	207	34336	Throttle Link
41	35541	Piston & Pin Ass'y. (Std.) (Incl. 43)	209	30200	Screw, 10-24 x 9/16"
41	35542	Piston & Pin Ass'y. (.010" OS) (Incl. 43)	215	32410	Control Knob
41	35543	Piston & Pin Ass'y. (.020" OS) (Incl. 43)	223	650451	Screw, 1/4-20 x 1"
42	35547A	Ring Set (Std.)	224	*36786	Intake Pipe Gasket
42	35548A	Ring Set (.010" OS)	238	650932	Screw, 10-32 x 49/64"
42	35549	Ring Set (.020 OS)	239	*34338	Air Cleaner Gasket
43	20381	Piston Pin Retaining Ring	241	35797	Air Cleaner Collar
45	36777	Connecting Rod Ass'y. (Incl. 46)	245	35066	Air Cleaner Filter
46	32610A	Connecting Rod Bolt	250	35065	Air Cleaner Cover
48	27241	Valve Lifter	260	36798	Blower Housing
50	37032	Camshaft (NCR)	261	30200	Screw, 10-24 x 9/16"
52	29914	Oil Pump Ass'y.	262	650831	Screw, 1/4-20 x 1/2"
69	*35261	Mounting Flange Gasket	263	36240	Trim Ring
70	34311E	Mounting Flange (Incl. 72 thru 83, 306)	275	36837A	Muffler
72	36083	Oil Drain Plug	275A	36790A	Muffler (Optional)
72A	28534	Oil Drain Plug			(NOTE: This muffler used together with Ref#'s 284,284A,416 & 417 make up an optional spark arrestor muffler).
75	27897	Oil Seal	277	650988	Screw, 1/4-20 x 2-5/16"
80	30574A	Governor Shaft	284	36663	Muffler Deflector (Incl. 284) (Optional)
81	30590A	Washer	284A	650821	Screw, 10-32 x 1/2" (Optional)
82	30591	Governor Gear Ass'y. (Incl. 81)	285	35000A	Starter Cup
83	30588A	Governor Spool	287	650926	Screw, 8-32 x 21/64"
86	650488	Screw, 1/4-20 x 1-1/4"	290	34357	Fuel Line
89	610961	Flywheel Key	292	26460	Fuel Line Clamp
90	611213	Flywheel	300	35586	Fuel Tank (Incl. 292 & 301)
92	650815	Belleville Washer	301	35355	Fuel Cap
93	650816	Flywheel Nut	305	35577	Oil Fill Tube
100	34443B	Solid State Ignition	306	*36996	"O"-Ring
101	610118	Spark Plug Cover			
103	651007	Screw, Torx T-15, 10-24 x 15/16"			
110	36230	Ground Wire			
110A	36816	Ground Wire			
119	*37028	Cylinder Head Gasket			
120	36825	Cylinder Head			
125	37288	Exhaust Valve (Std.) (Incl. 151)			
126	37289	Intake Valve (Std.) (Incl. 151)			
130	6021A	Screw, 5/16-18 x 1-1/2"			
135	35395	Resistor Spark Plug (RJ19LM)			
150	31672	Valve Spring			

CRAFTSMAN 4-CYCLE ENGINE

MODEL: 143.994024

Ref. No.	Part No.	Part Name	Ref. No.	Part No.	Part Name
307	35499	"O"-Ring	416	35085	Spark Arrestor Kit (Incl. 417) (Optional)
309	650562	Screw, 10-32 x 1/2"	417	650821	Screw, 10-32 x 1/2" (Optional)
310	35578	Dipstick	900		Replacement Engine 750838A, order from 71-999
313	34080	Spacer	900		Replacement Short Block 750833A, order from 71-999
370A	36261	Lubrication Decal		181-1204-11	Operator's Manual
370B	35169	Control Decal			
370C	37199	Primer Decal			
370K	36695	Starter Decal			
380	640174	Carburetor (Incl. 184)			
390	590737	Rewind Starter			
		(NOTE: This engine could have been built with 590694 starter).			
400	37029A	Gasket Set (Incl. Items Marked *)			*Indicates Parts Included in Gasket Set, Ref. No. 400.
					RPM High 3050 to 3350 RPM Low 2400 to 2700

CARBURETOR NO. 640174

Ref. No.	Part No.	Part Name
	640174	Carburetor (incl. 184 of Engine Parts List)
1	631615	Throttle Shaft & Lever Assembly
2	631767	Throttle Return Spring
4	*631184	Dust Seal Washer
5	*631183	Dust Seal (Throttle)
6	640070	Throttle Shutter
7	*650506	Shutter Screw
16	631807	Fuel Fitting
17	651025	Throttle Crack Screw/Idle Speed Screw
18	630766	Tension Spring
20	640018	Idle Restrictor Screw
20A	640200	Idle Restrictor Screw Cap
25	631867	Float Bowl
27	*631024	Float Shaft
28	632019	Float
29	*631028	Float Bowl "O" Ring
30	*631021	Inlet Needle, Seat, & Clip (Incl. 31)
31	631022	Spring Clip
35	36045A	Primer Bulb/Retainer Ring
36	640080	Main Nozzle Tube
36A	632766	Carburetor Tube
37	*632547	"O" Ring, Main Nozzle Tub
40	640175	High Speed Bowl Nut
44	27110A	Bowl Nut Washer
47	*630748	Welch Plug, Idle Mixture Well
48	*631027	Welch Plug, Atmospheric Vent
48A	*631027	Welch Plug
60	632760	Repair Kit (Incl. Items Marked *)

REWIND STARTER NO. 590737

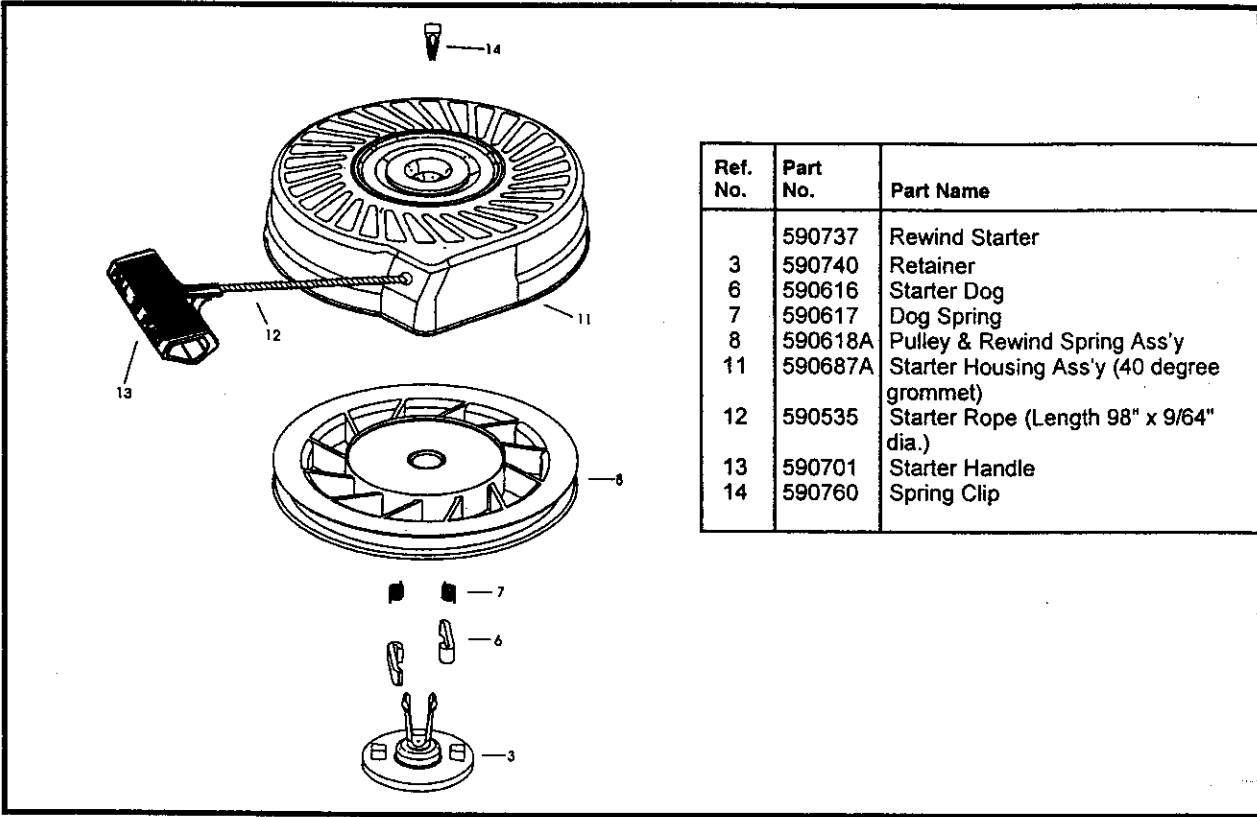

STARTER NO. 590694

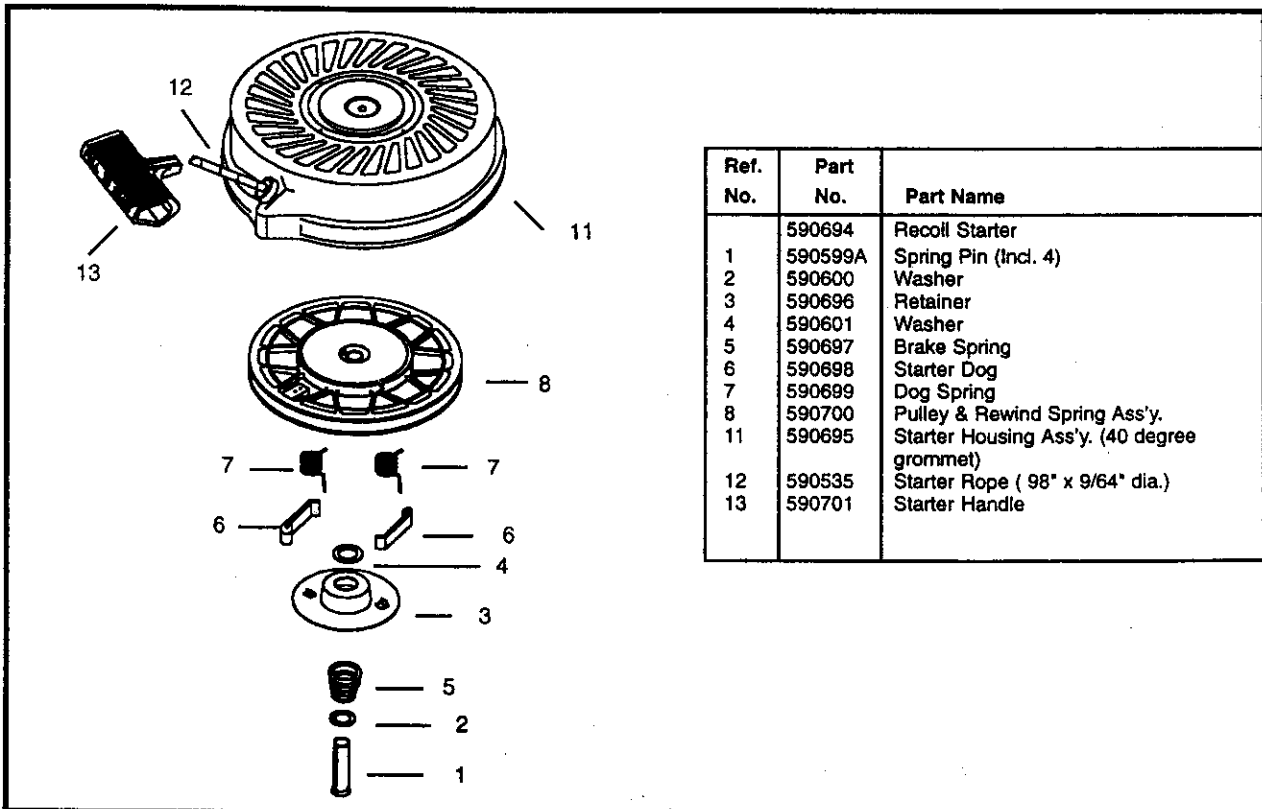

SEARS

operator's manual

MODEL NO. 143.994024

**4.0 RESERVE POWER
10 CUBIC INCH (163 cc)
DISPLACEMENT**

SOLID STATE IGNITION

CAUTION:

Read **RULES** for
Safe **OPERATION**
and **INSTRUCTIONS**
Carefully

How to ORDER Repair Parts

The Model Number can be found on a decal on the blower housing (See Figure 1). Always mention the Model Number when requesting service or repair parts for your Craftsman Engine.

All parts listed herein may be ordered from any SEARS, ROE-BUCK AND CO. or SEARS CANADA, INC. retail or catalog store. If the parts you need are not stocked locally, your order will be electronically transmitted to a Sears Repair Parts Distribution Center for expedited handling.

WHEN ORDERING REPAIR PARTS, ALWAYS GIVE THE FOLLOWING INFORMATION AS SHOWN IN THIS LIST.

1. The **PART NUMBER**
2. The **PART DESCRIPTION**
3. The **MODEL NUMBER**
4. The **NAME OF ITEM - ENGINE**

"Your Sears merchandise has added value when you consider that Sears has service units nationwide staffed with Sears trained technicians... professional technicians specifically trained on Sears products, having the parts, tools and equipment to insure that we meet our pledge to you ... we service what we sell."

**Sold by SEARS, ROEBUCK AND CO., CHICAGO, IL 60684 U.S.A.
and SEARS CANADA, INC., TORONTO, ONTARIO, CANADA**