

Owner's Manual

CRAFTSMAN[®] **6.75 HORSEPOWER** **21" MULTI-CUT** **POWER PROPELLED** **ROTARY LAWN MOWER**

Model No.
917.377961

- **Safety**
- **Assembly**
- **Operation**
- **Maintenance**
- **Español**
- **Repair Parts**

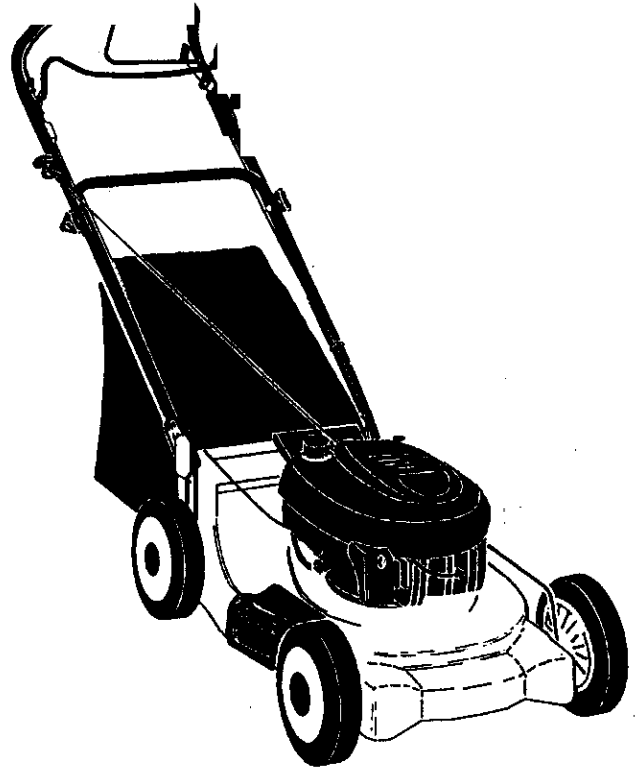

CAUTION:

Read and follow all
Safety Rules and Instructions
before operating this equipment

Sears, Roebuck and Co., Hoffman Estates, IL 60179
Visit our Craftsman website: www.sears.com/craftsman

TABLE OF CONTENTS

Warranty	2	Product Specifications	12
Safety Rules	2	Service and Adjustments	15
Assembly	4	Storage	16
Operation	6	Troubleshooting	17
Maintenance Schedule	11	Repair Parts	38
Maintenance	11	Parts Ordering	Back Cover

WARRANTY

LIMITED TWO YEAR WARRANTY ON CRAFTSMAN POWER MOWER

For two years from date of purchase, when this Craftsman Lawn Mower is maintained, lubricated, and tuned up according to the operating and maintenance instructions in the owner's manual, Sears will repair free of charge any defect in material or workmanship. If this Craftsman Lawn Mower is used for commercial or rental purposes, this warranty applies for only 90 days from the date of purchase.

This Warranty does not cover:

- Expendable items which become worn during normal use, such as rotary mower blades, blade adapters, belts, air cleaners and spark plug.
- Repairs necessary because of operator abuse or negligence, including bent crankshafts and the failure to maintain the equipment according to the instructions contained in the owner's manual.

Warranty service is available by returning the Craftsman power mower to the nearest Sears Service Center/Department in the United States. This warranty applies only while this product is in use in the United States.

This Warranty gives you specific legal rights, and you may also have other rights which vary from state to state.

SEARS, ROEBUCK AND CO., D/817 WA, HOFFMAN ESTATES, ILLINOIS 60179

SAFETY RULES

Safety standards require operator presence controls to minimize the risk of injury. Your unit is equipped with such controls. Do not attempt to defeat the function of the operator presence controls under any circumstances.

TRAINING:

- Read this operator's manual carefully. Become familiar with the controls and know how to operate your mower properly. Learn how to quickly stop mower.
- Do not allow children to use your mower. Never allow adults to use mower without proper instructions.
- Keep the area of operation clear of all persons, especially small children and pets.
- Use mower only as the manufacturer intended and as described in this manual.
- Do not operate mower if it has been dropped or damaged in any manner.

Always have damage repaired before using your mower.

- Do not use accessory attachments that are not recommended by the manufacturer. Use of such attachments may be hazardous.
- The blade turns when the engine is running.

PREPARATION:

- Always thoroughly check the area to be mowed and clear it of all stones, sticks, wires, bones, and other foreign objects. These objects will be thrown by the blade and can cause severe injury.
- Always wear safety glasses or eye shields when starting and while using your mower.
- Dress properly. Do not operate mower when barefoot or wearing open sandals. Wear only solid shoes with good traction when mowing.

- Check fuel tank before starting engine. Do not fill gas tank indoors, when the engine is running or when the engine is hot. Allow the engine to cool for several minutes before filling the gas tank. Clean off any spilled gasoline before starting the engine.
- Always make wheel height adjustments before starting your mower. Never attempt to do this while the engine is running.
- Mow only in daylight or good artificial light.

OPERATION:

- Keep your eyes and mind on your mower and the area being cut. Do not let other interests distract you.
- Do not mow wet or slippery grass. Never run while operating your mower. Always be sure of your footing - keep a firm hold on the handles and walk.
- Do not put hands or feet near or under rotating parts. Keep clear of the discharge opening at all times.
- Always stop the engine whenever you leave or are not using your mower, or before crossing driveways, walks, roads, and any gravel-covered areas.
- Never direct discharge of material toward bystanders nor allow anyone near the mower while you are operating it.
- Before cleaning, inspecting, or repairing your mower, stop the engine and make absolutely sure the blade and all moving parts have stopped. Then disconnect the spark plug wire and keep it away from the spark plug to prevent accidental starting.
- Do not continue to run your mower if you hit a foreign object. Follow the procedure outlined above, then repair any damage before restarting and operating your mower.
- Do not change the governor settings or overspeed the engine. Engine damage or personal injury may result.
- Do not operate your mower if it vibrates abnormally. Excessive vibration is an indication of damage; stop the engine, safely check for the cause of vibration and repair as required.
- Do not run the engine indoors. Exhaust fumes are dangerous.

- Never cut grass by pulling the mower towards you. Mow across the face of slopes, never up and down or you might lose your footing. Do not mow excessively steep slopes. Use caution when operating the mower on uneven terrain or when changing directions - maintain good footing.
- Never operate your mower without proper guards, plates, grass catcher or other safety devices in place.

MAINTENANCE AND STORAGE:

- Check the blade and the engine mounting bolts often to be sure they are tightened properly.
- Check all bolts, nuts and screws at frequent intervals for proper tightness to be sure mower is in safe working condition.
- Keep all safety devices in place and working.
- To reduce fire hazard, keep the engine free of grass, leaves or excessive grease and oil.
- Check grass catcher often for deterioration and wear and replace worn bags. Use only replacement bags that are recommended by and comply with specifications of the manufacturer of your mower.
- Always keep a sharp blade on your mower.
- Allow engine to cool before storing in any enclosure.
- Never store mower with fuel in the tank inside a building where fumes may reach an open flame or an ignition source such as a hot water heater, space heater, clothes dryer, etc.

 Look for this symbol to point out important safety precautions. It means **CAUTION!!! BECOME ALERT!!! YOUR SAFETY IS INVOLVED.**





 **CAUTION:** Always disconnect spark plug wire and place wire where it cannot contact spark plug in order to prevent accidental starting when setting up, transporting, adjusting or making repairs.

 **WARNING:** The engine exhaust from this product contains chemicals known to the State of California to cause cancer, birth defects, or other reproductive harm.



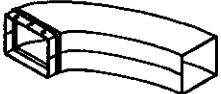

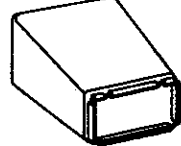

ACCESSORIES

These accessories were available when this lawn mower was produced. They are not shipped with your mower. They are also available at most Sears retail outlets and service centers. Most Sears stores can also order repair parts for you, when you provide the model number of your lawn mower. Some of these accessories may not apply to your lawn mower.

LAWN MOWER PERFORMANCE

 <p>CLIPPING DEFLECTOR FOR REAR DISCHARGE LAWN MOWERS</p>	 <p>MULCHER KITS</p>	 <p>STABILIZER</p>
 <p>GRASS CATCHERS FOR REAR DISCHARGE LAWN MOWERS</p>	 <p>GRASS CATCHERS FOR SIDE DISCHARGE LAWN MOWERS</p>	 <p>GAS CANS</p>

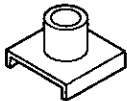
LAWN MOWER MAINTENANCE

 <p>MUFFLERS</p>		 <p>AIR FILTERS</p>		 <p>SPARK PLUGS</p>
 <p>BELTS</p>	 <p>BLADES</p>	 <p>BLADE ADAPTERS</p>	 <p>WHEELS</p>	 <p>ENGINE OIL</p>

ASSEMBLY

Read these instructions and this manual in its entirety before you attempt to assemble or operate your new lawn mower.

IMPORTANT: This lawn mower is shipped WITHOUT OIL OR GASOLINE in the engine.

Your new lawn mower has been assembled at the factory with the exception of those parts left unassembled for shipping purposes. To ensure safe and proper operation of your lawn mower, all parts and hardware you assemble must be tightened securely. Use the correct tools as necessary to ensure proper tightness. All parts such as nuts, washers, bolts, etc., necessary to complete the assembly have been placed in the parts bag.

TO REMOVE LAWN MOWER FROM CARTON

- Remove loose parts included with mower.
- Cut down two end corners of carton and lay end panel down flat.

- Remove all packing materials except padding between upper and lower handle and padding holding operator presence control bar to upper handle.
- Roll lawn mower out of carton and check carton thoroughly for additional loose parts.

HOW TO SET UP YOUR LAWN MOWER

TO UNFOLD HANDLE

IMPORTANT: Unfold handle carefully so as not to pinch or damage control cables.

- Raise lower handle section to operating position and squeeze the bottom ends of lower handle towards each other until the pin in handle can be inserted into one of the three height adjustment holes.
- Remove protective padding, raise upper handle section into place on lower handle and tighten both handle knobs.
- Remove any packing material from around control bar.

- Your handles may be adjusted for your mowing comfort. Refer to Service and Adjustments section of this manual.

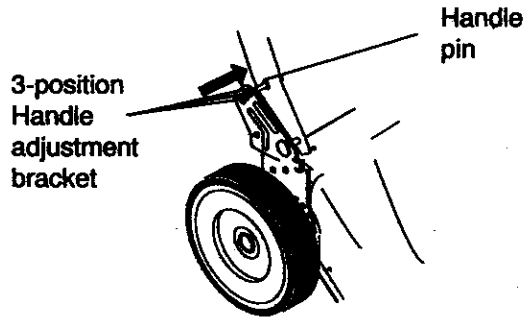
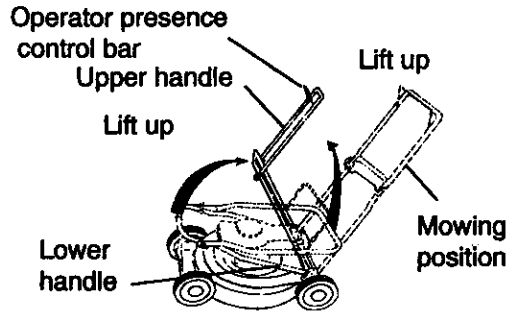

TO INSTALL ATTACHMENTS

Your lawn mower was shipped ready to be used as a mulcher. To convert to bagging or discharging; See OPERATION section of this manual.

OPERATION

KNOW YOUR LAWN MOWER

READ THIS OWNER'S MANUAL AND SAFETY RULES BEFORE OPERATING YOUR LAWN MOWER. Compare the illustrations with your lawn mower to familiarize yourself with the location of various controls and adjustments. Save this manual for future reference.

These symbols may appear on your lawn mower or in literature supplied with the product. Learn and understand their meaning.

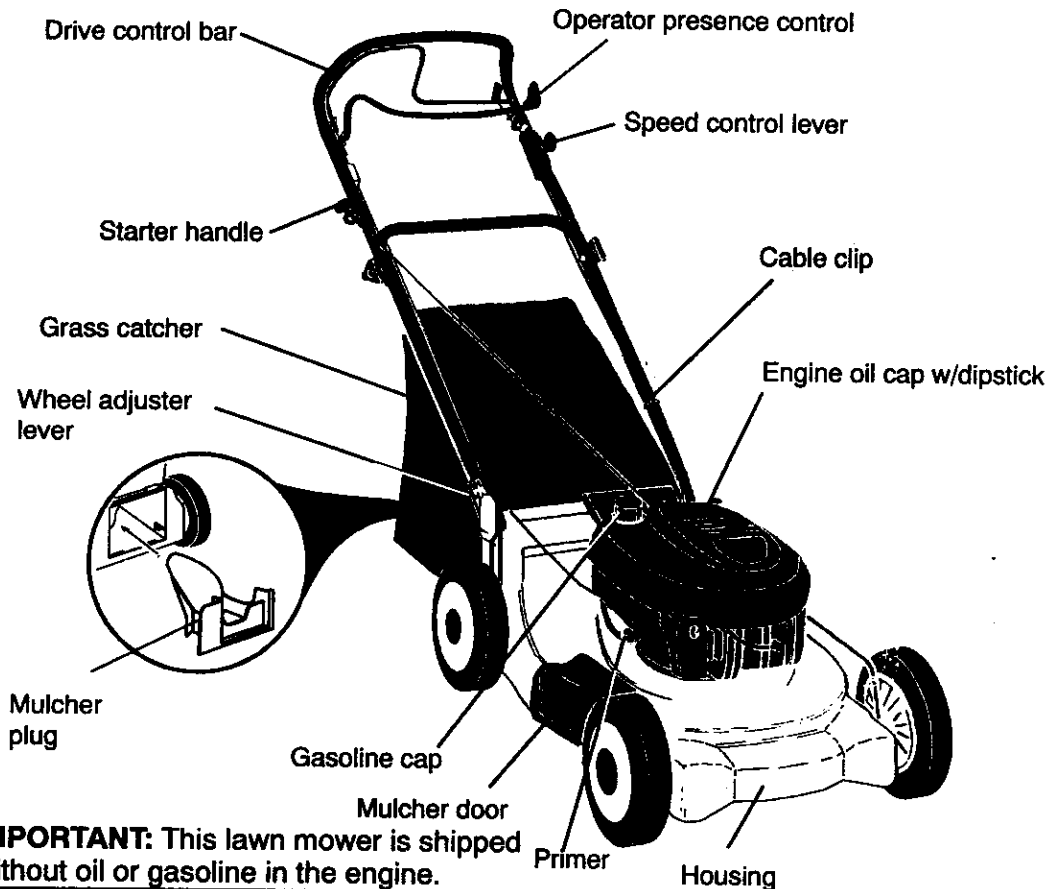
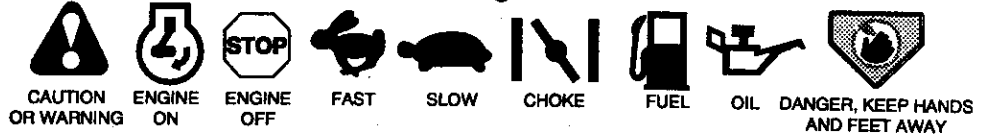

IMPORTANT: This lawn mower is shipped without oil or gasoline in the engine.

MEETS CPSC SAFETY REQUIREMENTS

Sears rotary walk-behind power lawn mowers conform to the safety standards of the American National Standards Institute and the U.S. Consumer Product Safety Commission. The blade turns when the engine is running.

Operator presence control - must be held down to the handle to start the engine. Release to stop the engine.

Primer - pumps additional fuel from the carburetor to the cylinder for use when starting a cold engine.

Starter handle - used for starting the engine.

Drive control bar - used to engage power-propelled forward motion of lawn mower.

Mulcher plug - Located at the rear discharge opening must be removed when converting to bagging operation.

The operation of any lawn mower can result in foreign objects thrown into the eyes, which can result in severe eye damage. Always wear safety glasses or eye shields while operating your lawn mower or performing any adjustments or repairs. We recommend a wide vision safety mask over spectacles or standard safety glasses.

HOW TO USE YOUR LAWN MOWER ENGINE SPEED

The engine speed was set at the factory for optimum performance. Speed is not adjustable.

ENGINE ZONE CONTROL

CAUTION: Federal regulations require an engine control to be installed on this lawn mower in order to minimize the risk of blade contact injury. Do not under any circumstances attempt to defeat the function of the operator control. The blade turns when the engine is running.

- Your lawn mower is equipped with an operator presence control bar which requires the operator to be positioned behind the lawn mower handle to start and operate the lawn mower.

TO ADJUST CUTTING HEIGHT

- All four wheels are adjusted by a single lever.
- Pull adjuster lever toward wheel. To raise mower, move lever forward to desired position. To lower mower, move the lever toward the rear.

Lower Wheels for high cut

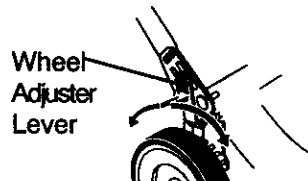

Raise Wheels for low cut

GROUND DRIVE SPEEDS

Your lawn mower provides multiple speeds to let you select the speed that suits you best.

- Lower speeds are for slow, heavy/thick grass cutting or trimming.
- Medium speeds are for normal grass cutting or trimming.
- High is for light cutting and for ground transport.

NOTE: Do not move speed control lever unless the engine is running

TO OPERATE DRIVE SYSTEM

- With engine running, select ground speed by moving speed control lever to desired position.
- To start forward motion, pull drive control bar back against handle.
- To stop forward motion, release drive control bar.

IMPORTANT: Always keep drive control bar fully engaged against handle when in use.

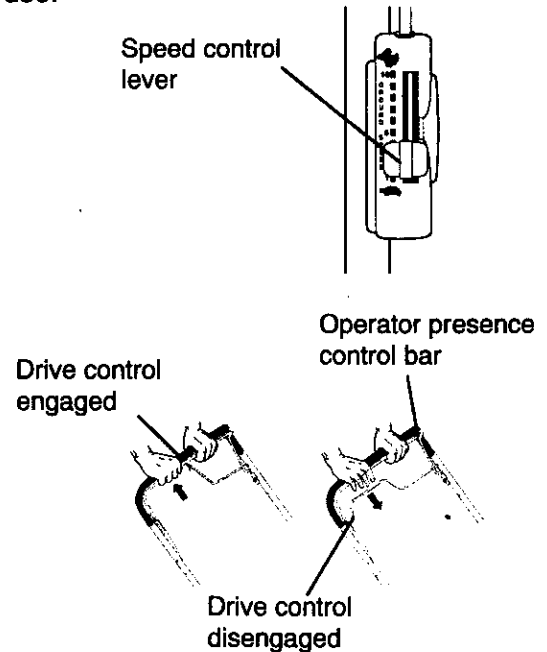

TO CONVERT MOWER

Your lawn mower was shipped ready to be used as a mulcher. To convert to bagging or discharging:

REAR BAGGING-

- Open rear door and remove mulcher plug. Store mulcher plug in a safe place.
- To convert to mulching or discharging operation, install mulcher plug into rear discharge opening of mower.

SIDE DISCHARGING-

- Rear door must be open.
- Open mulcher door and install discharge deflector under guard as shown.
- Mower is now ready for discharging operation.
- To convert to mulching or bagging operation, discharge deflector must be removed and mulcher door must be closed.

SIMPLE STEPS TO REMEMBER

WHEN CONVERTING YOUR LAWN MOWER

FOR MULCHING -

- Rear mulcher plug installed.
- Mulcher door closed.

FOR REAR BAGGING -

- Rear mulcher plug removed.
- Grass catcher installed.
- Mulcher door closed.

FOR SIDE DISCHARGING -

- Rear mulcher plug installed.
- Side discharge deflector installed.

CAUTION: Do not run your lawn mower without rear mulcher plug in place or approved grass catcher in place. Never attempt to operate the lawn mower with the rear door removed or propped open.

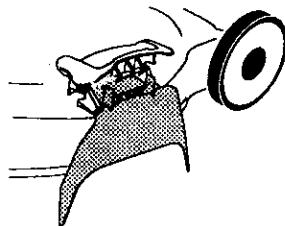
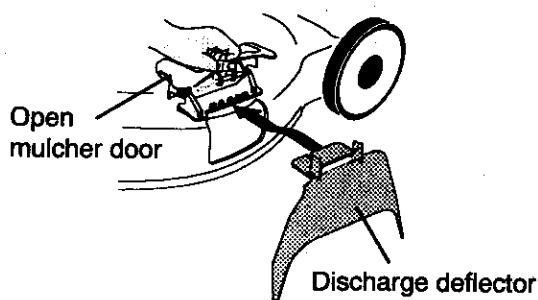
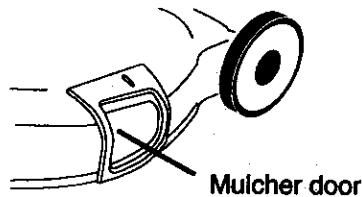
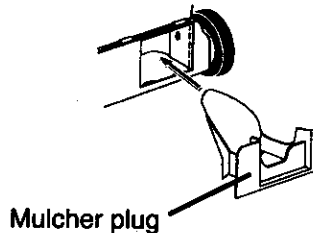

TO ATTACH GRASS CATCHER

- Lift the rear door of the lawn mower and place the grass catcher frame hooks into the slots of the rear door.
- The grass catcher is secured to the lawn mower housing when the rear door is lowered onto the grass catcher frame.

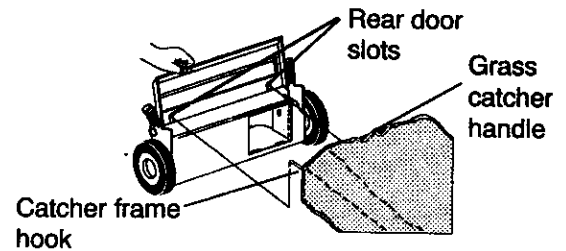

CAUTION: Do not run your lawn mower without rear mulcher plug or approved grass catcher in place. Never attempt to operate the lawn mower with the rear door removed or propped open.

TO EMPTY GRASS CATCHER

- Lift up on grass catcher using the frame handle.
- Remove grass catcher with clippings from under lawn mower handle.
- Empty clippings from bag using both frame handle and bag handle.

NOTE: Do not drag the bag when emptying; it will cause unnecessary wear.

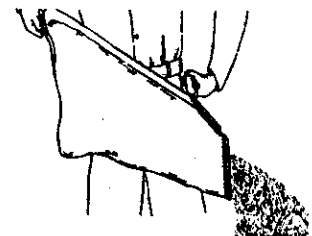

BEFORE STARTING ENGINE

OIL

Your lawn mower is shipped without oil in the engine.

- Be sure mower is level and area around oil fill is clean.
- Remove engine oil cap and fill to the full line on the dipstick.

NOTE: Allow oil to settle down into engine for accurate dipstick reading.

- Engine holds 27 ozs. of oil. For type and grade of oil to use, see "ENGINE" in Maintenance section of this manual.
- Pour oil slowly. Do not over fill.

- Check oil level before each use. Add oil if needed. Fill to full line on dipstick.
- To read proper level, tighten engine oil cap each time.
- Reinstall engine oil cap and tighten.
- Change the oil after every 25 hours of operation or each season. You may need to change the oil more often under dusty, dirty conditions.

GAS

- Fill fuel tank. Use fresh, clean, regular unleaded gasoline with a minimum of 87 octane. (Use of leaded gasoline will increase carbon and lead oxide deposits and reduce valve life). Do not mix oil with gasoline. Purchase fuel in quantities that can be used within 30 days to assure fuel freshness.

⚠WARNING: Experience indicates that alcohol blended fuels (called gasohol or using ethanol or methanol) can attract moisture which leads to separation and formation of acids during storage. Acidic gas can damage the fuel system of an engine while in storage. To avoid engine problems, the fuel system should be emptied before storage of 30 days or longer. Drain the gas tank, start the engine and let it run until the fuel lines and carburetor are empty. Use fresh fuel next season. See Storage Instructions for additional information. Never use engine or carburetor cleaner products in the fuel tank or permanent damage may occur.

TO START ENGINE

- To start a cold engine, push primer three (3) times before trying to start. Use a firm push. This step is not usually necessary when starting an engine which has already run for a few minutes.
- Hold operator presence control bar down to the handle.
- To stop engine, release operator presence control bar.

NOTE: In cooler weather it may be necessary to repeat priming steps. In warmer weather over priming may cause flooding and engine will not start. If you do flood engine wait a few minutes before attempting to start and do not repeat priming steps.

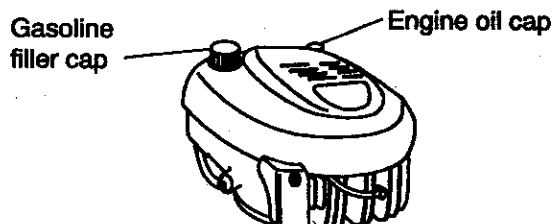

MOWING TIPS

- For most cutting conditions and better bagging performance, the engine speed should be set in the fast position.
- Under certain conditions, such as when mowing very tall grass, raise the mower height on the first cut to reduce pushing effort, to avoid overheating the engine, and to avoid leaving clumps of grass clippings. Make the second cut to the desired height.
- For extremely heavy cutting, reduce the width of cut.
- Pores in cloth grass catchers can become filled with dirt and dust with use and the catcher will collect less grass. To prevent this, regularly hose catcher off with water and let dry before use.

MULCHING MOWING TIPS

IMPORTANT: For best performance, keep mower housing free of built-up grass and trash. See "Cleaning" in MAINTENANCE section of this manual.

- The special mulching blade will recut the grass clippings many times and reduce them in size so that as they fall onto the lawn they will disperse into the grass and not be noticed. Also, the mulched grass will biodegrade quickly to provide nutrients for the lawn. Always mulch with your highest engine (blade) speed as this will provide the best recutting action of the blades.
- Avoid cutting your lawn when it is wet. Wet grass tends to form clumps and interferes with the mulching action. The best time to mow your lawn is the early afternoon. At this time the grass has dried and the newly cut area will not be exposed to the direct sun.
- For best results, adjust the lawn mower cutting height so that the lawn mower cuts off only the top one-third of the grass blades. If the lawn is overgrown it will be necessary to raise the height of cut to reduce pushing effort and to keep from overloading the engine and leaving clumps of mulched grass. For extremely heavy mulching, reduce your width of cut by overlapping previously cut path and mow slowly.
- Certain types of grass and grass conditions may require that an area be mulched a second time to completely hide the clippings. When doing a second cut, mow across or perpendicular to the first cut path.
- Change your cutting pattern from week to week. Mow north to south one week then change to east to west the next week. This will help prevent matting and graining of the lawn.



Max 1/3

MAINTENANCE

MAINTENANCE SCHEDULE		BEFORE EACH USE				AFTER EACH USE				EVERY 10 HOURS				EVERY 25 HOURS OR EVERY SEASON				BEFORE STORAGE				SERVICE DATES							
FILL IN DATES AS YOU COMPLETE REGULAR SERVICE																													
M O W E R	Check for Loose Fasteners	✓																											
	Clean/Inspect Grass Catcher (If Equipped)	✓	✓																										
	Clean Lawn Mower		✓																										
	Clean Under Drive Cover (Power-Propelled Mowers)				✓																								
	Check drive belt/pulleys (Power-Propelled Mowers)								✓																				
	Check/Sharpen/Replace Blade								✓ ₃																				
	Lubrication Chart								✓																				
	Clean Battery/Recharge (Electric Start Mowers)								✓																				
E N G I N E	Check Engine Oil Level	✓																											
	Change Engine Oil								✓ _{1,2}																				
	Clean Air Filter								✓																				
	Inspect Muffler								✓																				
	Clean or Replace Spark Plug								✓																				
Replace Air Filter Paper Cartridge								✓ ₂																					

- 1 - Change more often when operating under a heavy load or in high ambient temperatures.
- 2 - Service more often when operating in dirty or dusty conditions.
- 3 - Replace blades more often when mowing in sandy soil.
- 4 - Change 48 hours at end of season.

GENERAL RECOMMENDATIONS

The warranty on this lawn mower does not cover items that have been subjected to operator abuse or negligence. To receive full value from the warranty, operator must maintain mower as instructed in this manual. Some adjustments will need to be made periodically to properly maintain your unit. All adjustments in the Service and Adjustments section of this manual should be checked at least once each season.

- Once a year, replace the spark plug, replace air filter element and check blade for wear. A new spark plug and clean/new air filter element assures proper air-fuel mixture and helps your engine run better and last longer.
- Follow the maintenance schedule in this manual.

BEFORE EACH USE

- Check engine oil level.
- Check for loose fasteners.

LUBRICATION

Keep unit well lubricated (See "LUBRICATION CHART").

LUBRICATION CHART

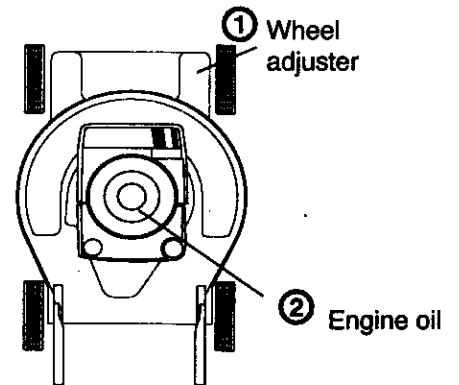

- ① Spray lubricant
- ② Refer to MAINTENANCE "ENGINE" section.

IMPORTANT: Do not oil or grease plastic wheel bearings. Viscous lubricants will attract dust and dirt that will shorten the life of the self lubricating bearings. If you feel they must be lubricated, use only a dry, powdered graphite type lubricant sparingly.

PRODUCT SPECIFICATIONS

MODEL NUMBER	917.377961
SERIAL NUMBER	
DATE OF PURCHASE	
HORSEPOWER:	6.75
GASOLINE CAPACITY/ TYPE:	1.5 QUARTS UNLEADED REGULAR
OIL TYPE (API-SF/SG/SH):	SAE 30 (ABOVE 32°F) SAE 5W-30 (BELOW 32°F)
OIL CAPACITY:	27 OZS.
SPARK PLUG(GAP: .030")	CHAMPION RJ19LM or J19LM
VALVE CLEARANCE:	INTAKE: .004 - .008 EXHAUST: .004 - .008
SOLID STATE IGNITION	
AIR GAP:	.0125 IN.
BLADE BOLT TORQUE:	35-40 FT. LBS.
<ul style="list-style-type: none"> The model and serial numbers will be found on a decal attached to the rear of the lawn mower housing. Record both serial number and date of purchase in space provided above. 	

LAWN MOWER

Always observe safety rules when performing any maintenance.

TIRES

- Keep tires free of gasoline, oil, or insect control chemicals which can harm rubber.
- Avoid stumps, stones, deep-ruts, sharp objects and other hazards that may cause tire damage.

BLADE CARE

For best results, mower blade must be kept sharp. Replace bent or damaged blades.

TO REMOVE BLADE

- Disconnect spark plug wire from spark plug and place wire where it cannot come in contact with spark plug.
- Turn lawn mower on its side. Make sure air filter and carburetor are up.
- Use a wood block between blade and mower housing to prevent blade from turning when removing blade bolt.
- Protect your hands with gloves and/or wrap blade with heavy cloth.
- Remove blade bolt by turning counter-clockwise.

- Remove blade and attaching hardware (bolt, lock washer and hardened washer).

NOTE: Remove the blade adapter and check the key inside hub of blade adapter. The key must be in good condition to work properly. Replace adapter if damaged.

TO REPLACE BLADE

- Position the blade adapter on the engine crankshaft. Be sure key in adapter and crankshaft keyway are aligned.
- Position blade on the blade adapter aligning the two (2) holes in the blade with the raised lugs on the adapter.
- Be sure the trailing edge of blade (opposite sharp edge) is up toward the engine.
- Install the blade bolt with the lock washer and hardened washer into blade adapter and crankshaft.
- Use block of wood between blade and lawn mower housing and tighten the blade bolt, turning clockwise.
- The recommended tightening torque is 35-40 ft. lbs.

IMPORTANT: BLADE BOLT IS GRADE 8 HEAT TREATED.

TO SHARPEN BLADE

NOTE: We do not recommend sharpening blade - but if you do, be sure the blade is balanced.

Care should be taken to keep the blade balanced. An unbalanced blade will cause eventual damage to lawn mower or engine.

- The blade can be sharpened with a file or on a grinding wheel. Do not attempt to sharpen while on the mower.
- To check blade balance, drive a nail into a beam or wall. Leave about one inch of the straight nail exposed. Place center hole of blade over the head of the nail. If blade is balanced, it should remain in a horizontal position. If either end of the blade moves downward, sharpen the heavy end until the blade is balanced.

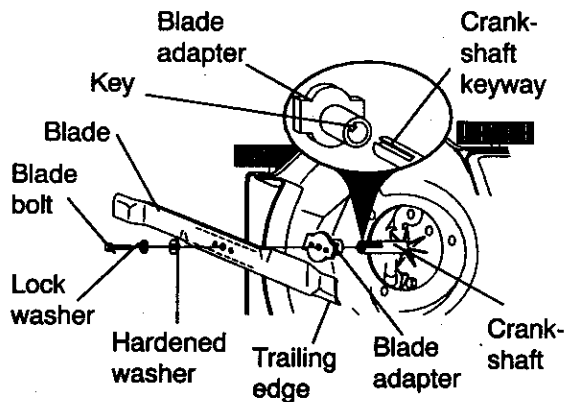

GRASS CATCHER

- The grass catcher may be hosed with water, but must be dry when used.
- Check your grass catcher often for damage or deterioration. Through normal use it will wear. If catcher needs replacing, replace only with a manufacturer approved replacement catcher. Give the lawn mower model number when ordering.

DRIVE WHEELS

Check rear drive wheels each time you mow to be sure they move freely. The wheels not turning freely means trash, grass cuttings, etc., may be inside the drive wheel and dust cover area and must be cleaned out to free drive wheels. If necessary to clean the drive wheels, check both rear wheels.

- Remove hubcaps and locknuts.
- Remove wheels from wheel adjuster axles.
- Remove any trash or grass cuttings from inside the dust cover, pinion and/

or drive wheel gear teeth.

- If you remove the drive pinions, wipe clean with dry cloth. Reassemble dry. Do not lubricate. Do not use oil or grease.
- The pinion gear, on both sides of the mower, are the same, however, they must be installed correctly. If installed incorrectly, the drive system will not work.
- There are arrows embossed on both sides of the pinion gear. With the arrow at the top of the pinion, the arrow must point towards front of mower. If the arrow points to the rear, turn the pinion around and assemble to mower.
- Place wheels back on adjuster axles.
- Replace locknuts and hubcaps.

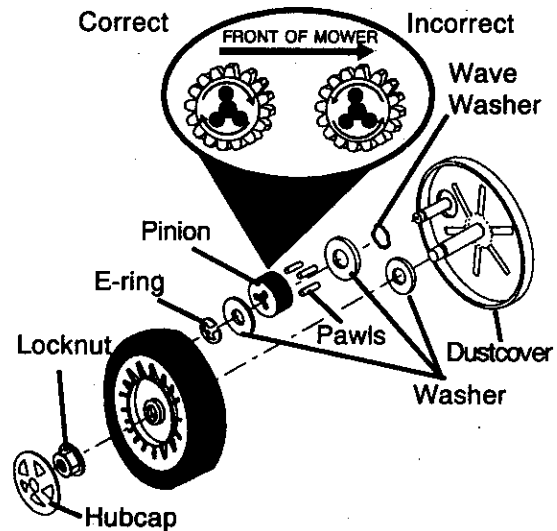

ENGINE LUBRICATION

Use only high quality detergent oil rated with API service classification SF, SG or SH. Select the oil's SAE viscosity grade according to your expected operating temperature.

SAE VISCOSITY GRADES	
← 5W-30	SAE 30 →
°F	-20° 0° 30° 32° 40° 60° 80° 100°
°C	-30° -20° -10° 0° 10° 20° 30° 40°
TEMPERATURE RANGE ANTICIPATED BEFORE NEXT OIL CHANGE	

NOTE: Although multi-viscosity oils (5W30, 10W30 etc.) improve starting in cold weather, these multi-viscosity oils will result in increased oil consumption when used above 32°F. Check your engine oil level more frequently to avoid possible engine damage from running low on oil. Change the oil after every 25 hours of operation or at least once a year if the lawn mower is not used for 25 hours in one year.

Check the crankcase oil level before starting the engine and after each five (5) hours of continuous use. Tighten oil plug securely each time you check the oil level.

TO CHANGE ENGINE OIL

NOTE: Before tipping lawn mower to drain oil, drain fuel tank by running engine until fuel tank is empty.

- Disconnect spark plug wire from spark plug and place wire where it cannot come in contact with spark plug.
- Remove engine oil cap; lay aside on a clean surface.
- Tip lawn mower on its side as shown and drain oil into a suitable container. Rock lawn mower back and forth to remove any oil trapped inside of engine.
- Wipe off any spilled oil on lawn mower and on side of engine.
- Fill engine with oil. Fill only to the "FULL" line on the dipstick. **DO NOT OVER FILL.**
- Replace engine oil cap.
- Reconnect spark plug wire to spark plug.

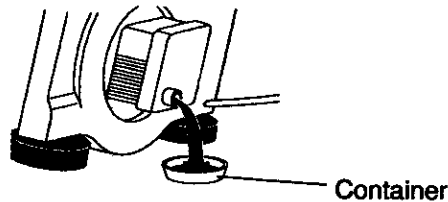

AIR FILTER

Your engine will not run properly and may be damaged by using a dirty air filter. Replace the air filter every year, more often if you mow in very dusty, dirty conditions. Do not wash air filter.

TO CHANGE AIR FILTER

- Loosen cover knob.
- Swing cover down and remove from hinge.
- Pull paper filter out of air cleaner body.
- Clean air cleaner cover and body.
- Install a new paper filter.
- Reinstall cover to air cleaner body. Be sure hinge is assembled properly.
- Swing cover up and tighten cover knob. (Do not overtighten).

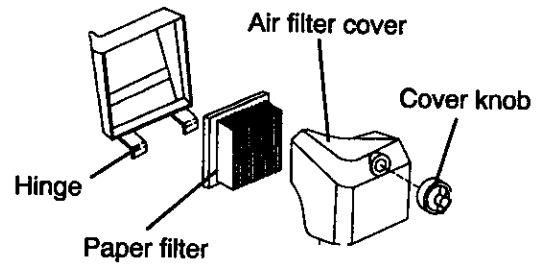

MUFFLER

Inspect and replace corroded muffler as it could create a fire hazard and/or damage.

SPARK PLUG

Change your spark plug each year to make your engine start easier and run better. Set spark plug gap at .030 inch.

CLEANING

IMPORTANT: For best performance, keep mower housing free of built-up grass and trash. Clean underside of mower housing after each use.

CAUTION: Disconnect spark plug wire from spark plug and place wire where it cannot come in contact with the spark plug.

- Clean the underside of your lawn mower by scraping to remove build-up of grass and trash.
- Clean engine often to keep trash from accumulating. A clogged engine runs hotter and shortens engine life.
- Keep finished surfaces and wheels free of all gasoline, oil, etc.
- We do not recommend using a garden hose to clean lawn mower unless the electrical system, muffler, air filter and carburetor are covered to keep water out. Water in engine can result in shortened engine life.

SERVICE AND ADJUSTMENTS

CAUTION: BEFORE PERFORMING ANY SERVICE OR ADJUSTMENTS:

- Release control bar and stop engine.
- Make sure the blade and all moving parts have completely stopped.
- Disconnect spark plug wire from spark plug and place where it cannot come in contact with plug.

LAWN MOWER

TO ADJUST CUTTING HEIGHT

See "TO ADJUST CUTTING HEIGHT" in the Operation section of this manual.

REAR DEFLECTOR

The rear deflector, attached between the rear wheels of your lawn mower, is provided to minimize the possibility that objects will be thrown out the rear of the lawn mower into the operator's mowing position. If the rear deflector becomes damaged, it should be replaced.

TO ADJUST HANDLE

The handle on your lawn mower has three (3) height positions - adjust to height that suits you.

- Squeeze the bottom ends of lower handle towards each other until the pin in handle can be inserted into one of the three height adjustment holes.

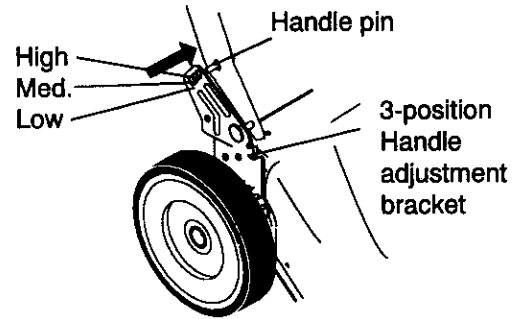

ENGINE

ENGINE SPEED

Your engine speed has been factory set. Do not attempt to increase engine speed or it may result in personal injury. If you believe that the engine is running too fast or too slow, take your lawn mower to an authorized service center/department for repair and adjustment.

CARBURETOR

Your carburetor has a non-adjustable fixed main jet for mixture control. If your engine does not operate properly due to suspected carburetor problems, take your lawn mower to an authorized service center/department for repair and adjustment.

IMPORTANT: Never tamper with the engine governor, which is factory set for proper engine speed. Overspeeding the engine above the factory high speed setting can be dangerous. If you think the engine-governed high speed needs adjusting, contact your nearest **AUTHORIZED** service center, which has proper equipment and experience to make any necessary adjustments.

STORAGE

Immediately prepare your lawn mower for storage at the end of the season or if the unit will not be used for 30 days or more.

LAWN MOWER

When lawn mower is to be stored for a period of time, clean it thoroughly, remove all dirt, grease, leaves, etc. Store in a clean, dry area.

- Clean entire lawn mower (See "CLEANING" in the Maintenance section of this manual).
- Lubricate as shown in the Maintenance section of this manual.
- Be sure that all nuts, bolts, screws, and pins are securely fastened. Inspect moving parts for damage, breakage and wear. Replace if necessary.
- Touch up all rusted or chipped paint surfaces; sand lightly before painting.

HANDLE

- You can fold your lawn mower handle for storage.
- Loosen the two (2) handle knobs on sides of the upper handle and allow handle to fold down to the rear.
- Squeeze the bottom ends of lower handle toward each other until pins in handle clear the brackets and pivot entire handle assembly forward and allow it to rest on mower.
- When setting up your handle from the storage position, the lower handle will require manually locking into the mowing position.

IMPORTANT: When folding the handle for storage or transportation be sure to fold the handle as shown or you may damage the control cables.

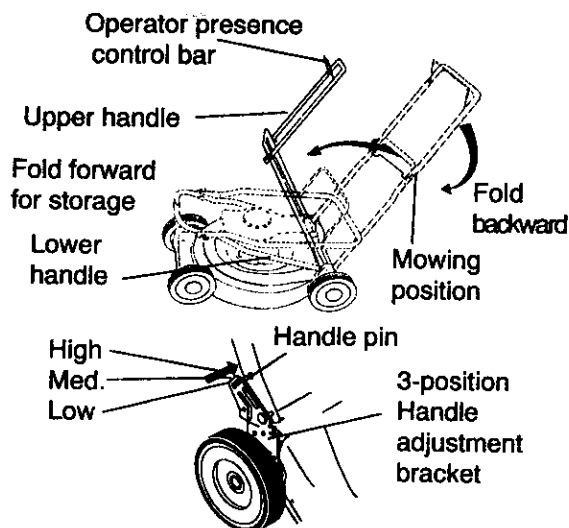

ENGINE

FUEL SYSTEM

IMPORTANT: It is important to prevent gum deposits from forming in essential fuel system parts such as carburetor, fuel filter, fuel hose, or tank during storage. Also, experience indicates that alcohol blended fuels (called gasohol or using ethanol or methanol) can attract moisture which leads to separation and formation of acids during storage. Acidic gas can damage the fuel system of an engine while in storage.

- Drain the fuel tank.
- Start the engine and let it run until the fuel lines and carburetor are empty.
- Never use engine or carburetor cleaner products in the fuel tank or permanent damage may occur.
- Use fresh fuel next season.

NOTE: Fuel stabilizer is an acceptable alternative in minimizing the formation of fuel gum deposits during storage. Add stabilizer to gasoline in fuel tank or storage container. Always follow the mix ratio found on stabilizer container. Run engine at least 10 minutes after adding stabilizer to allow the stabilizer to reach the carburetor. Do not drain the gas tank and carburetor if using fuel stabilizer.

ENGINE OIL

Drain oil (with engine warm) and replace with clean engine oil. (See "ENGINE" in the Maintenance section of this manual).

CYLINDER

- Remove spark plug.
- Pour one ounce (29 ml) of oil through spark plug hole into cylinder.
- Pull starter handle slowly a few times to distribute oil.
- Replace with new spark plug.

OTHER

- Do not store gasoline from one season to another.
- Replace your gasoline can if your can starts to rust. Rust and/or dirt in your gasoline will cause problems.
- If possible, store your unit indoors and cover it to give protection from dust and dirt.
- Cover your unit with a suitable protective cover that does not retain moisture. Do not use plastic. Plastic cannot breathe which allows condensation to form and will cause your unit to rust.

IMPORTANT: Never cover mower while engine and exhaust areas are still warm.

CAUTION: Never store the lawn mower with gasoline in the tank inside a building where fumes may reach an open flame or spark. Allow the engine to cool before storing in any enclosure.

TROUBLESHOOTING CHART

PROBLEM	CAUSE	CORRECTION
Will not start	<ol style="list-style-type: none"> 1. Dirty air filter. 2. Out of fuel. 3. Stale fuel. 4. Water in fuel. 5. Spark plug wire is disconnected. 6. Bad spark plug. 7. Loose blade or broken blade adapter. 8. Control bar in released position 9. Control bar defective 	<ol style="list-style-type: none"> 1. Clean/replace air filter. 2. Fill fuel tank. 3. Drain tank and refill with fresh clean fuel. 4. Drain fuel tank and carburetor and refill tank with fresh gasoline. 5. Connect wire to plug. 6. Replace spark plug. 7. Tighten blade bolt or replace blade adapter. 8. Depress control bar to handle. 9. Replace control bar.
Loss of power	<ol style="list-style-type: none"> 1. Rear of lawn mower housing/blade dragging in heavy grass. 2. Cutting too much grass. 3. Dirty air filter. 4. Buildup of grass, leaves and trash under mower. 5. Too much oil in engine. 6. Walking speed too fast. 	<ol style="list-style-type: none"> 1. Set in "Higher Cut" position. 2. Set in "Higher Cut" position. 3. Clean/replace air filter. 4. Clean underside of mower housing. 5. Check oil level. 6. Cut at slower walking speed.
Poor cut - uneven	<ol style="list-style-type: none"> 1. Worn, bent or loose blade. 2. Buildup of grass, leaves, and trash under mower. 	<ol style="list-style-type: none"> 1. Replace blade. Tighten blade bolt. 2. Clean underside of mower housing.
Excessive vibration	<ol style="list-style-type: none"> 1. Worn, bent or loose blade. 2. Bent engine crankshaft. 	<ol style="list-style-type: none"> 1. Replace blade. Tighten blade bolt. 2. Contact an authorized service center/department.
Starter rope hard to pull	<ol style="list-style-type: none"> 1. Engine flywheel brake is on when control bar is released. 2. Bent engine crankshaft 3. Blade adapter broken. 4. Blade dragging in grass. 	<ol style="list-style-type: none"> 1. Depress control bar to upper handle before pulling starter rope. 2. Contact an authorized service center/department. 3. Replace blade adapter. 4. Move lawn mower to cut grass on to hard surface to start engine.

TROUBLESHOOTING CHART

PROBLEM	CAUSE	CORRECTION
Grass catcher not filling (if so equipped)	<ol style="list-style-type: none"> 1. Cutting height too low. 2. Lift on blade worn off. 3. Catcher not venting air. 	<ol style="list-style-type: none"> 1. Raise cutting height. 2. Replace blade. 3. Clean grass catcher.
Hard to push	<ol style="list-style-type: none"> 1. Grass is too high or wheel height is too low. 2. Rear of lawn mower housing/blade dragging in grass. 3. Grass catcher too full. 4. Handle height position not right for you. 	<ol style="list-style-type: none"> 1. Raise cutting height. 2. Raise rear of lawn mower housing one (1) setting higher. 3. Empty grass catcher. 4. Adjust handle height to suit.
Loss of drive	<ol style="list-style-type: none"> 1. Belt wear. 2. Belt off of pulley. 3. Drive cable worn or broken. 4. Dirt in drive pinions. 	<ol style="list-style-type: none"> 1. Check/replace drive belt. 2. Check/reinstall drive belt. 3. Replace drive cable. 4. Clean drive pinions.

SERVICE NOTES

ROTARY LAWN MOWER -- MODEL NO. 917.377961

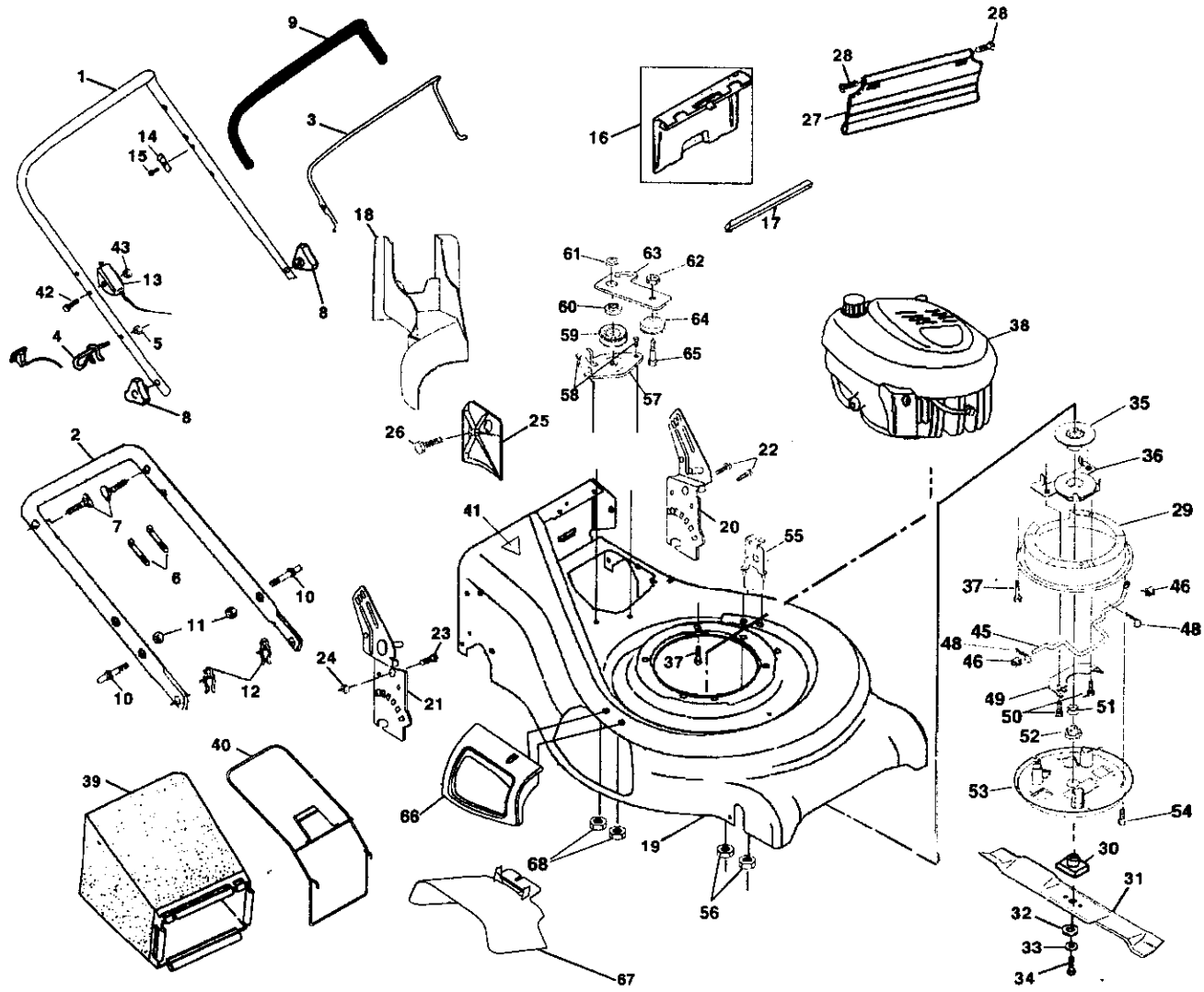

ROTARY LAWN MOWER -- MODEL NO. 917.377961

KEY NO.	PART NO.	DESCRIPTION	KEY NO.	PART NO.	DESCRIPTION
1	167163	Handle, Upper Dix Comf. (Includes Grip)	39	169294	Grass Catcher Bag
2	161105X479	Handle, Lower	40	161358	Grass Catcher Frame
3	131036	Bail, Cont. Wire Dix Comf. Blk	41	85463	Danger Decal
4	132001	Guide, Rope, Side	42	144929	Screw
5	63601	Nut, Hex Lockwasher 1/4-20	43	751152	Nut
6	66426	Wire, Tie	45	168034	Rod, Pulley Engage
7	131959	Bolt, Handle 5/16-18 x 1.75	46	166041	Bushing
8	87692	Knob, Handle	48	169605	Retainer Clip
9	164265	Grip, Hdl Foam Smooth	49	168039X008	Clamp
10	161551	Bolt, Sq. Neck	50	54583	Screw
11	73990500	Nut, Hex Lockwasher Ins. 5/16-18 UNC	51	169980	Spacer
12	51793	Cotter, Hairpin	52	170047	Wave Washer
13	162949	Engine Zone control	53	166037	Belt Cover, Bottom
14	850733X004	Bracket, Upstop	54	750097	Screw
15	83816	Screw, Hex Washer Head Tapping 10-2	55	166383X479	Cable Support Bracket
16	162085	Kit, Door Rear	56	63601	Nut
17	161548	Seal, Door	57	166391X004	Bracket Assy.
18	165261	Plug, Mulcher	58	57808	Screw
19	166907	Kit, Housing	59	166042	V-Groove Pulley
20	161568X479	Handle, Bracket Asm. Left	60	166050	Idler Arm Spacer
21	168227X479	Handle, Bracket Asm. Right	61	145212	Flange Nut
22	150078	Screw, Hex Wshd	62	155552	Locknut
23	163183	Bolt, Hex Head 5/16-18 x 5/8	63	166022X008	Idler Arm
24	63124	Nut, Hex Lock Wshr 5/16-18	64	166043	Idler Pulley
25	161333	Baffle, Side	65	160829	Shoulder Bolt
26	163409	Screw 12 x 5/8	66	166885	Door Assy.
27	161550	Skirt	67	166028	Multi Cut Guard
28	88652	Screw, Hinge 1/4-20 x 1.25	68	88349	Nut
29	166036X479	Belt Cover, Top	--	161058	Warning Decal (Not Shown)
30	851514	Adapter, Blade w/key Longer	--	170112	Owner's Manual
31	159267	Blade, 21"			
32	851074	Washer, Hardened			
33	850263	Lockwasher, Helical Spring 3/8	Available accessories not included with lawn mower:		
34	851084	Screw, Hex Head 3/8-24 x 1.38	71	33623	Gas Can (2.5 gal.)
35	166032	Pulley, Fixed	71	33500	Fuel Stabilizer
36	170045	Bearing Support Assy.	71	33300	SAE 30W Oil (27 oz.)
37	150406	Bolt, Engine			
38	-----	Engine (See Breakdown)			
		Craftsman 143.996710			

88

REPAIR PARTS

ROTARY LAWN MOWER -- MODEL NO. 917.377961

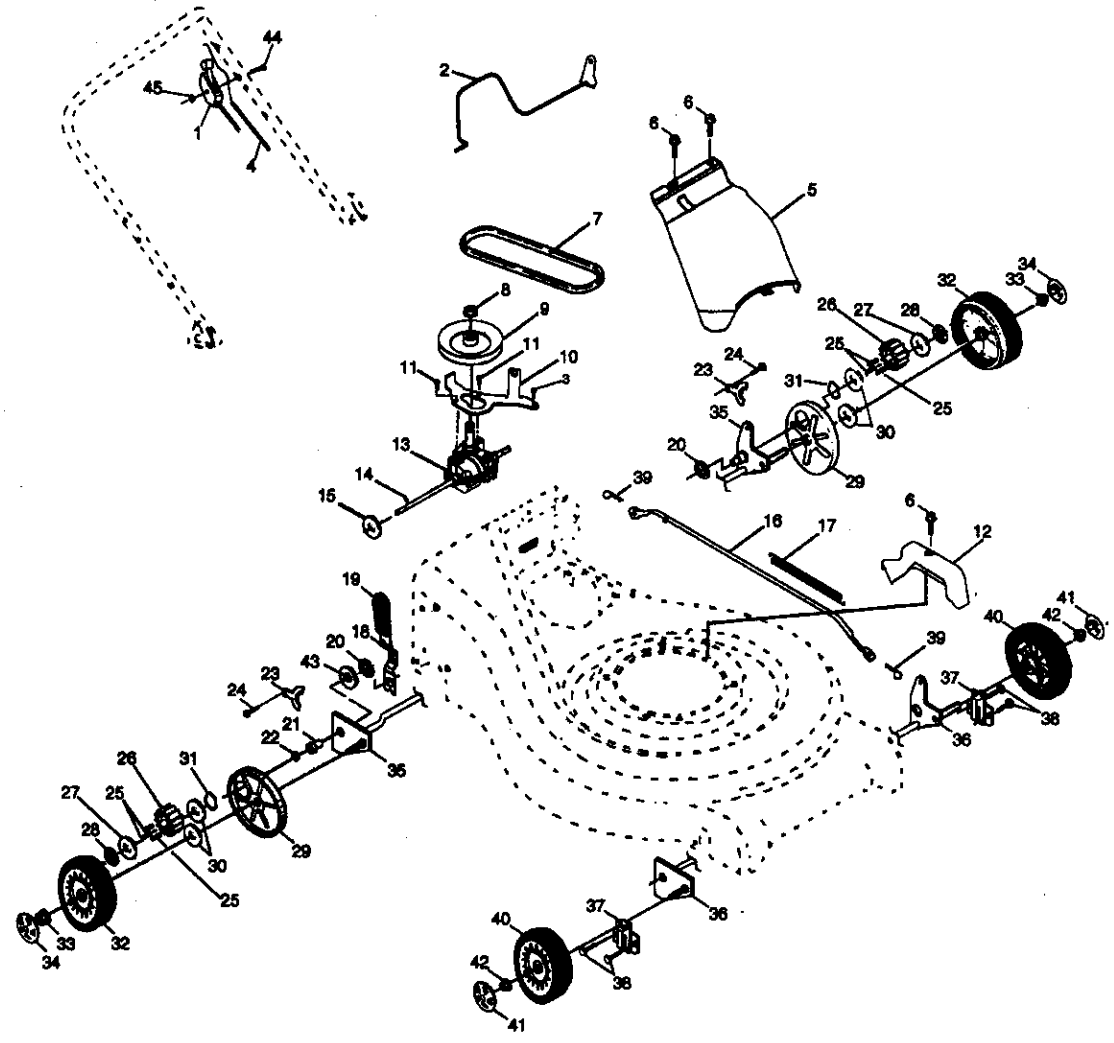

ROTARY LAWN MOWER -- MODEL NO. 917.377961

KEY NO.	PART NO	DESCRIPTION	KEY NO.	PART NO	DESCRIPTION
1	166047	Speed Control	23	161118X004	Retainer Drive Asm. Stmp.
2	167259	Bail Control Drive	24	57808	Screw Hex Head Tapping 1/4-20 x .75
3	54583	Screw	25	170011	Drive Pawl
4	170050	Drive Cable	26	166450	Pinion, Drive RH
5	161537	Cover Drive	27	52160	Washer
6	750634	Screw Thdrol 10-25 x .50	28	12000058	E-Ring 7/16
7	166060	V-Belt	29	88080	Cover, Dust Wheel
8	132010	Nut Lock Flanged 3/8-16 Zinc	30	67725	Washer 1/2 x 1-1/2 x .134
9	166049	Pulley Driven	31	57143	Wave Washer
10	166021X004	Belt Keeper Bracket	32	150342	Wheel 9 x 2
11	17541011	Screw Hex Wash Head 10-24 X .668	33	145212	Nut Hex Flange Lock
12	166189	Pivot Rod Cover	34	150181	Hubcap, Mag Platinum 9"
13	166388	Transmission Asm.	35	160785X004	Shaft Asm. Rear
14	145354	Pin Spring Thrust	36	160786X004	Shaft Asm. Front
15	57079	Washer Hardened	37	161463	Retainer Front Shaft
16	161584	Rod Connecting	38	163409	Screw 12 x 5/8
17	161602	Spring Extension	39	700279	Clip Retainer
18	160477X004	Spring Selector	40	150339	Wheel 8 x 2
19	167650	Knob Selector Spring	41	150182	Hubcap, Mag Platinum 8"
20	12000022	E-Ring 7/8	42	83923	Nut, Hex Flange Lock 3/8-16
21	163365	Bearing Support	43	19572216	Washer
22	169911	Bearing Ball	44	144929	Screw 1/4 x 2.12
			45	751152	Locknut

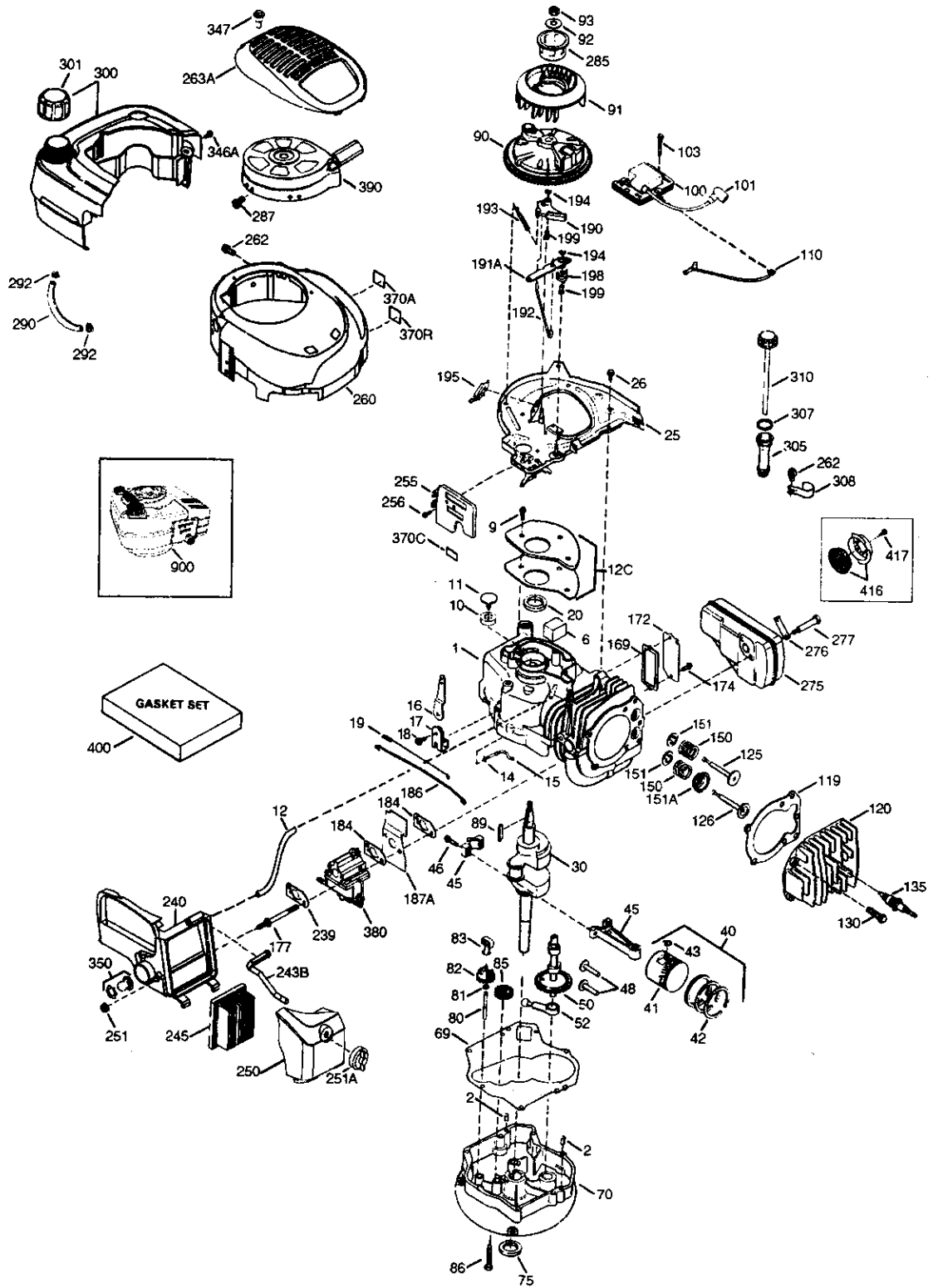

KEY NO.	PART NO.	DESCRIPTION	KEY NO.	PART NO.	DESCRIPTION
1	36177	Cylinder (Incl. 2,10,12,20 & 125)	151	31673	Lower Valve Spring Cap
2	27652	Dowel Pin	151A	40016A	Intake Valve Seal
6	36059	Breather Element	169	27234A	* Valve Spring Box Gasket
9	590568	Screw, 10-24 x 3/4"	172	32755	Valve Spring Box Cover
10	36002	Breather Valve Body	174	30200	Screw, 10-24 x 9/16"
11	36003A	Check Valve	177	650925A	Carburetor Mounting Stud
12	32447	Breather Tube	184	36183	Carburetor Gasket
12C	36005A	* Breather Cover & Gasket	186	36009	Governor Link
14	28277	Flat Washer	187A	37148	Air Baffle
15	36006	Governor Rod (Machined)	190	36013	Brake Lever Ass'y.
16	36008	Governor Lever	191A	36012	Brake Control Lever
17	31335	Governor Lever Clamp	192	36016	Brake Control Lever Link
18	651018	Screw, Torx T-15, 8-32 x 19/64"	193	36015	Brake Spring
19	36103	Governor Spring	194	36014	Retaining Ring
20	36010	Oil Seal	195	610973	Terminal Ass'y.
25	37149	Blower Housing Baffle Ass'y. (Incl. 195)	198	36017	Brake Control Lever Spring
26	650802	Screw, 1/4-20 x 5/8"	199	36018	Brake Lever Bushing
30	36178	Crankshaft	239	36048	* Carburetor To Air Cleaner Gasket
40	40004	Piston, Pin, Ring Set (Std.)	240	36190	Air Cleaner Body (Incl. 239 & 350)
40	40005	Piston, Pin, Ring Set (.010 OS)	243B	651041	Air Cleaner Stud
41	36070	Piston & Pin Ass'y. (Std.) (Incl. 43)	245	36046	Air Cleaner Filter
41	36071	Piston & Pin Ass'y. (.010 OS) (Incl. 43)	250	36191	Air Cleaner Cover
42	40006	Ring Set (Std.)	251	650928	Lock Nut, 1/4-20
42	40007	Ring Set (.010 OS)	251A	650933	Wing Nut, 1/4-20
43	20381	Piston Pin Retaining Ring	255	36193	Control Plate
45	36023A	Connecting Rod Ass'y. (Incl. 46)	256	650983	Screw, 8-32 x 21/64"
46	32610A	Connecting Rod Bolt	260	36188	Blower Housing
48	36030	Valve Lifter	262	650737	Screw, 1/4-20 x 1/2"
50	36031A	Camshaft (MCR)	263A	36192	Starter Grill
52	29914	Oil Pump Ass'y.	275	36107A	Muffler
69	36032A	* Mounting Flange Gasket	276	36043	Locking Plate
70	37271	Mounting Flange (Incl. 72 thru 85)	277	650927	Screw, 5/16-18 x 2-11/32"
75	36010	Oil Seal	285	34449A	Starter Cup
80	30574A	Governor Shaft	287	650926	Screw, 8-32 x 21/64"
81	30590A	Washer	290	29774	Fuel Line
82	30591	Governor Gear Ass'y. (Incl. 81)	292	26460	Fuel Line Clamp
83	36057	Governor Spool	300	36189	Fuel Tank (Incl. 301)
85	36034	Idler Gear	301	36246	Fuel Cap
86	650924	Screw, 1/4-20 x 1-9/16"	305	36063	Oil Fill Tube
89	611154	Flywheel Key	307	35499	"O" Ring
90	611155	Flywheel	308	36040	Fill Tube Clip
91	611156	Flywheel Fan	310	36064	Dipstick
92	650815	Belleville Washer	346A	28763	Screw, 10-32 x 35/64"
93	650816	Flywheel Nut	347	650898A	Screw, 10-32 x 27/32"
100	34443B	Solid State Ignition	350	36045	Primer
101	610118	Spark Plug Cover	370A	36261	Lubrication Decal
103	651007	Screw, Torx T-15, 10-24 x 15/16"	370C	37318	Primer Decal
110	36054	Ground Wire	370R	37317	Warning Decal
119	36061	* Cylinder Head Gasket	380	640020A	Carburetor (Incl. 184, 187A & 239)
120	36187	Cylinder Head	390	590739	Rewind Starter
125	36471	Exhaust Valve (Std.) (Incl. 151)	400	36062D	Gasket Set (Incl. Items Marked *)
125	36472	Exhaust Valve (1/32" OS)	416	36085	Spark Arrestor Kit (Incl. 417) (Optional)
126	29314C	Intake Valve (Std.) (Incl. 151)	417	650821	Screw, 10-32 x 1/2" (Optional)
130	6021A	Screw, 5/16-18 x 1-1/2"	900	-----	Replacement Engine
135	35395	Resistor Spark Plug (RJ19LM)	900	-----	NONE
150	31672	Valve Spring	-----	-----	Replacement Short Block 750791C, order from 71-999 RPM High 2900 to 3200

NOTE: This engine could have been built with 590702 starter.

NOTE: All component dimensions given in U.S. inches 1 inch = 25.4 mm

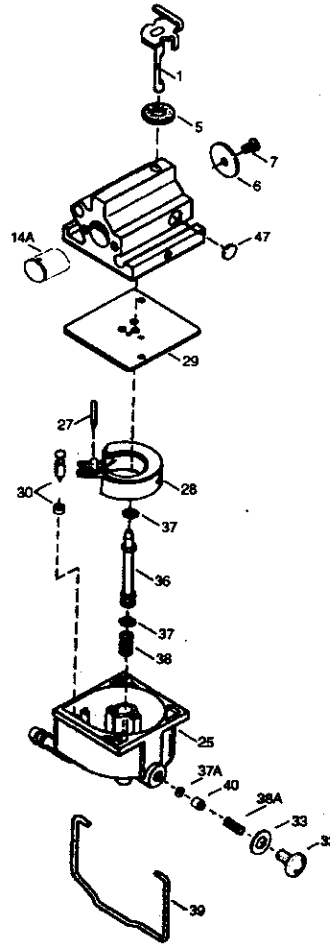

KEY NO.	PART NO.	DESCRIPTION
—	640020A	Carburetor (Incl. 187B & 239 of Engine Parts List)
1	632539	Throttle Shaft & Lever Assembly
5	632593	Dust Seal
6	632541	Throttle Shutter
7	650506	Throttle Shutter Screw
14A	632773	Venturi
25	632675A	Float Bowl
27	632544	Float Shaft
28	632543	Float
29	632548	Float Bowl to Body Gasket
30	632709	Inlet Needle & Seat
32	632672	Bowl Drain Screw
33	632673	Bowl Drain Washer
36	640022	Main Nozzle Tube
37	632547	"O" Ring
37A	632547	"O" Ring, Main Nozzle Tube
38	632545	Spring, Main Nozzle Tube
38A	632545	Spring
39	632549	Float Bowl Retainer
40	640021	Main Fuel Jet
47	632554	Welch Plug, Idle Mixing Well

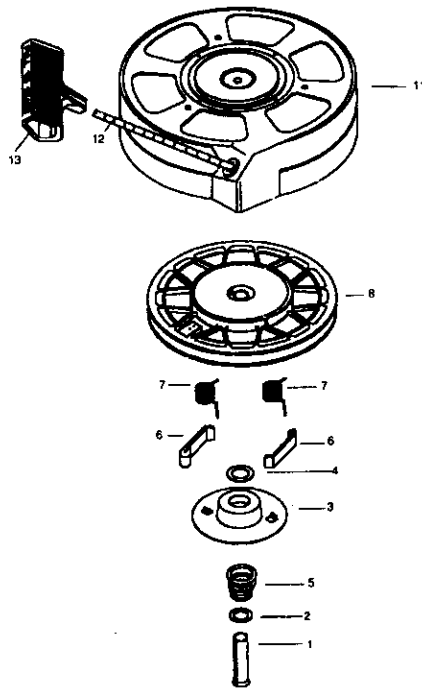

KEY NO.	PART NO.	DESCRIPTION
—	590702	Recoil Starter
1	590599A	Spring Pin (Incl. 4)
2	590600	Washer
3	590696	Retainer
4	590601	Washer
5	590697	Brake Spring
6	590698	Starter Dog
7	590699	Dog Spring
8	590700	Pulley & Rewind Spring Ass'y.
11	590703	Starter Housing Ass'y. (40 degree grommet)
12	590535	Starter Rope (98" X 9/64" dia.)
13	590701	Starter Handle

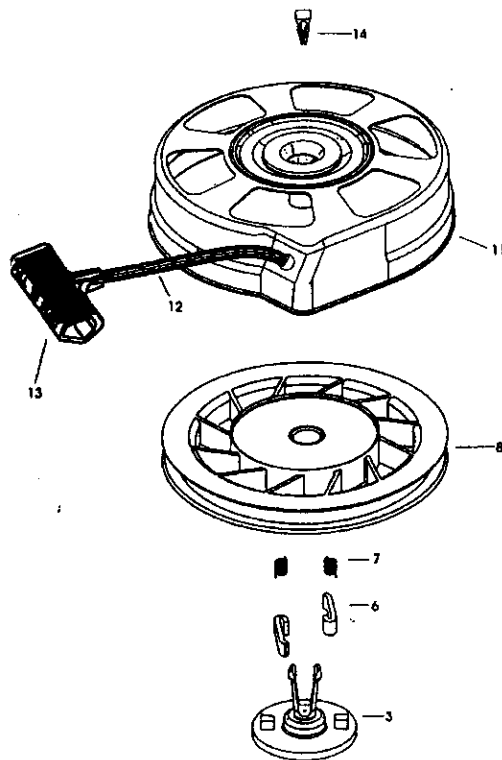

KEY NO.	PART NO.	DESCRIPTION
—	590739	Rewind Starter
3	590740	Retainer
6	590616	Starter Dog
7	590617	Dog Spring
8	590618A	Pulley & Rewind Spring Ass'y
11	590638	Starter Housing Ass'y (40 degree grommet)
12	590535	Starter Rope (Length 98" x 9/64" dia.)
13	590701	Starter Handle
14	590760	Spring Clip

For in-home major brand repair service:

Call 24 hours a day, 7 days a week

1-800-4-MY-HOMESM (1-800-469-4663)

Para pedir servicio de reparación a domicilio

1-800-676-5811

In Canada for all your service and parts needs call

Au Canada pour tout le service ou les pièces

1-800-665-4455

For the repair or replacement parts you need:

Call 6 am - 11 pm CST, 7 days a week

PartsDirectSM

1-800-366-PART (1-800-366-7278)

Para ordenar piezas con entrega a domicilio

1-800-659-7084

**For the location of a Sears Parts and Repair Center
in your area:**

Call 24 hours a day, 7 days a week

1-800-488-1222

**For information on purchasing a Sears Maintenance
Agreement or to inquire about an existing Agreement:**

Call 9 am - 5 pm, Monday - Saturday

1-800-827-6655

