

CRAFTSMAN®

8.5 Horsepower
26 Inch Dual Stage
120V. Electric Start
SNOWTHROWER

MODEL NO.
536.886190

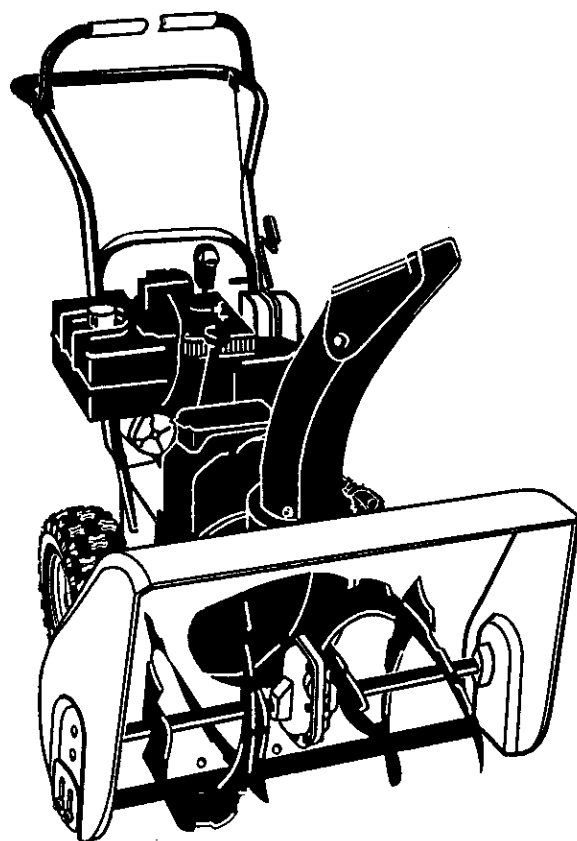

Caution:
Read and follow all Safety
Rules and Operating
Instructions before first use
of this product.

SEARS, ROEBUCK AND CO., Hoffman Estates, IL 60179 U.S.A.

761301 09/17/97

SAFETY

ASSEMBLY

OPERATION

MAINTENANCE

PARTS LIST

ESPAÑOL

TABLE OF CONTENTS

Table of Contents	2	Service and Adjustments	17-21
Warranty	2	Storage	22
Safety Rules	2-4	Troubleshooting	23
Contents of Shipping Carton	4-5	Repair Parts	24-32
Assembly	5-8	Engine Repair Parts	33-37
Operation	8-14	Spanish(Español)	38-63
Maintenance	14-16	Parts Ordering/Service	Back Cover

WARRANTY STATEMENT

LIMITED TWO-YEAR WARRANTY ON CRAFTSMAN SNOW THROWER

For two years from the date of purchase, when this Craftsman Snow Thrower is maintained, lubricated, and tuned up according to the operating and maintenance instructions in the owner's manual, Craftsman will repair, free of charge, any defect in material or workmanship. If this Craftsman Snow Thrower is used for commercial or rental purposes, this warranty applies for only 90 days from the date of purchase.

This warranty does not cover the following:

- Items which become worn during normal use, such as spark plugs, drive belts and shear pins.
- Repairs necessary because of operator abuse or negligence, including bent crank shafts and the failure to maintain the equipment according to the instructions contained in the owner's manual.

WARRANTY SERVICE IS AVAILABLE BY RETURNING THE CRAFTSMAN SNOW THROWER TO THE NEAREST CRAFTSMAN SERVICE CENTER/DEPARTMENT IN THE UNITED STATES. THIS WARRANTY APPLIES ONLY WHILE THIS PRODUCT IS IN USE IN THE UNITED STATES.

This warranty gives you specific legal rights, and you may also have other rights which may vary from state to state.

Sears, Roebuck and Co., D817WA, Hoffman Estates, IL 60179



SAFETY RULES



Look for this symbol to point out important safety precautions. It means---
ATTENTION!!! Become alert!!! Your safety is involved.



CAUTION: Always disconnect spark plug wire and place wire where it cannot contact spark plug to prevent accidental starting when setting-up, transporting, adjusting or making repairs.

IMPORTANT: Safety standards require operator presence controls to minimize the risk of injury. Your snow thrower is equipped with such controls. Do not attempt to defeat the function of the operator presence control under any circumstances.



California Proposition 65

WARNING: The engine exhaust from this product contains chemicals known to the State of California to cause cancer, birth defects or other reproductive harm.

TRAINING

1. Read the operator's manual carefully. Be thoroughly familiar with the controls and the proper use of the snow thrower. Know how to stop the snow thrower and disengage the controls quickly.
2. Never allow children to operate the snow thrower and keep them away while it is operating. Never allow adults to operate the snow thrower without proper instruction. Do not carry passengers.
3. Keep the area of operation clear of all persons, particularly small children and pets.
4. Exercise caution to avoid slipping or falling, especially when operating in reverse.

PREPARATION

1. Thoroughly inspect the area where the snow thrower is to be used and remove all doormats, sleds, boards, wires and other foreign objects.

2. Disengage all clutches before starting the engine (motor).
 3. Do not operate the snow thrower without wearing adequate winter outer garments. Wear footwear that will improve footing on slippery surfaces.
 4. Handle fuel with care; it is highly flammable.
 - (a) Use an approved fuel container.
 - (b) Never remove fuel tank cap or add fuel to a running engine or hot engine.
 - (c) Fill fuel tank outdoors with extreme care. Never fill fuel tank indoors.
 - (d) Replace fuel tank cap securely and wipe up spilled fuel.
 - (e) Never store fuel or snow thrower with fuel in the tank inside of a building where fumes may reach an open flame or spark.
 - (f) Check fuel supply before each use, allowing space for expansion as the heat of the engine (motor) and/or sun can cause fuel to expand.
 5. Use extension cords and receptacles as specified by the manufacturer for all snow throwers with electric drive motors or electric starting motors.
 6. Adjust the snow thrower height to clear gravel or crushed rock surfaces.
 7. Never attempt to make any adjustments while the engine (motor) is running (except when specifically recommended by the manufacturer).
 8. Let engine (motor) and snow thrower adjust to outdoor temperatures before starting to clear snow.
 9. Always wear safety glasses or eye shields during operation or while performing an adjustment or repair to protect eyes from foreign objects that may be thrown from the snow thrower.
- ating on or crossing gravel drives, walks, or roads. Stay alert for hidden hazards or traffic.
 5. After striking a foreign object, stop the engine (motor), remove the wire from the spark plug, disconnect the cord on electric motors, thoroughly inspect the snow thrower for any damage, and repair the damage before restarting and operating the snow thrower.
 6. If the snow thrower should start to vibrate abnormally, stop the (motor) and check immediately for the cause. Vibration is generally a warning of trouble.
 7. Stop the engine (motor) whenever you leave the operating position, before unclogging the auger/impeller housing or discharge guide, and when making any repairs, adjustments, or inspections.
 8. When cleaning, repairing, or inspecting, make certain the auger/impeller and all moving parts have stopped. Disconnect the spark plug wire and keep the wire away from the plug to prevent accidental starting.
 9. Take all possible precautions when leaving the snow thrower unattended. Disengage the auger/impeller, stop engine, and remove key.
 10. Do not run the engine indoors, except when starting the engine and for transporting the snow thrower in or out of the building. Open the outside doors; exhaust fumes are dangerous (containing CARBON MONOXIDE, an ODORLESS and DEADLY GAS).
 11. Do not clear snow across the face of slopes. Exercise caution when changing direction on slopes. Do not attempt to clear steep slopes.
 12. Never operate the snow thrower without proper guards, plates or other safety protective devices in place.
 13. Never operate the snow thrower near glass enclosures, automobiles, window wells, drop-offs, and the like without proper adjustment of the snow discharge angle. Keep children and pets away.
 14. Do not overload the machine capacity by attempting to clear snow at too fast a rate.
 15. Never operate the snow thrower at high transport speeds on slippery surfaces. Look behind and use care when backing.
 16. Never direct discharge at bystanders or allow anyone in front of the snow thrower.

OPERATION

1. Do not operate this machine if you are taking drugs or other medication which can cause drowsiness or affect your ability to operate this machine.
2. Do not use this machine if you are mentally or physically unable to operate this machine safely.
3. Do not put hands or feet near or under rotating parts. Keep clear of the discharge opening at all times.
4. Exercise extreme caution when oper-

17. Disengage power to the auger/impeller when snow thrower is transported or not in use.
18. Use only attachments and accessories approved by the manufacturer of the snow thrower (such as tire chains, electric start kits, etc.).
19. Never operate the snow thrower without good visibility or light. Always be sure of your footing, and keep a firm hold on the handles. Walk; never run.

MAINTENANCE AND STORAGE

1. Check shear bolts and other bolts frequently for proper tightness to be sure the snow thrower is in safe working condition.
2. Never store the snow thrower with fuel in the fuel tank inside a building where ignition sources are present such as hot water and space heaters, clothes dryers, and the like. Allow the engine to cool before storing in any enclosure.
3. Always refer to operator's manual instructions for important details if the snow thrower is to be stored for an extended period.

Contents of Parts Bag (actual size)

- 1 - Owner's Manual (not shown)
- 2 - Parts Bags (not shown)
- *Non-Assembly Parts, found in tool box located on belt cover.

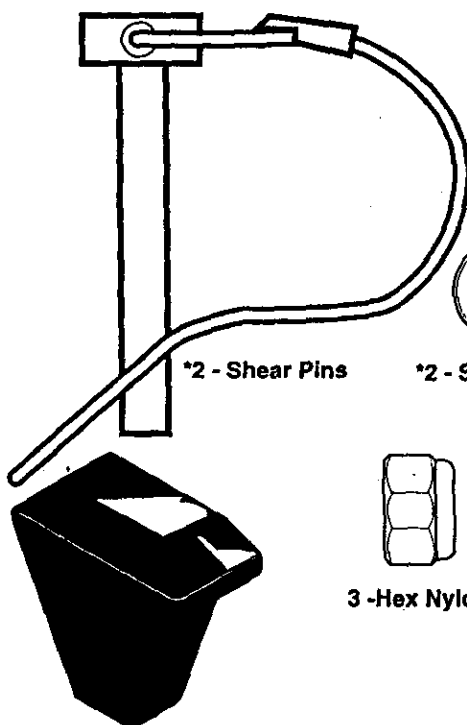

1- Shifter Knob



1 - Washer, Hvsptlk



1- Nut, 1/2-13 Hexjam

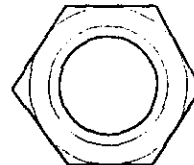

*2 - Spare Spacers

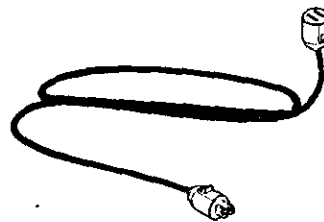

1 - Starter Motor Cord 10Ft.



3 -Hex Nylon Nuts, 5/16-18

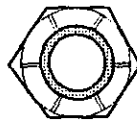

4 - Flatwashers 11/32 In.

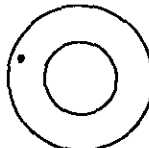

1- Nut, 5/16-18 Reghex

4. Maintain or replace safety and instruction labels, as necessary.
5. Run the snow thrower a few minutes after throwing snow to prevent freeze-up of the auger/impeller.

⚠ WARNING: This snow thrower is for use on sidewalks, driveways and other ground level surfaces.

Caution should be exercised while using on steep sloping surfaces. **DO NOT USE SNOW THROWER ON SURFACES ABOVE GROUND LEVEL** such as roofs of residences, garages, porches or other such structures or buildings.

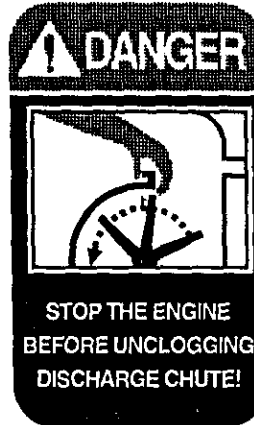

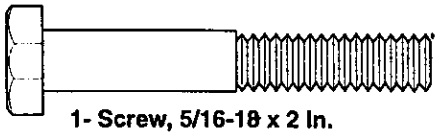

1- Screw, 5/16-18 x 2 In.

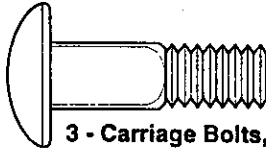

3 - Carriage Bolts, 5/16-18x1.00 In.

Parts packed separately in carton (not shown full size)



2 - Ignition Keys
(Attached to engine in plastic bag)



1 - container Fuel Stabilizer



1 - container 5W30 oil

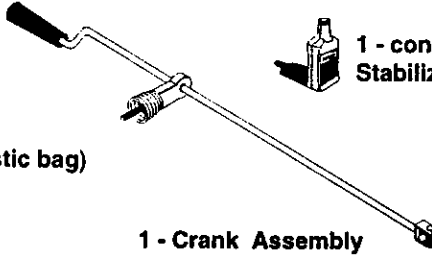

1 - Crank Assembly

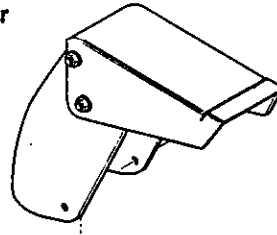

1 - Snow Chute Assembly

ASSEMBLY

CAUTION: Always wear safety glasses or eye shields while assembling snow thrower.

TOOLS REQUIRED FOR ASSEMBLY

- 1 - Knife to cut carton and plastic ties
- 2 - 1/2 inch wrenches (or adjustable wrenches)
- 2 - 9/16 inch wrenches (or adjustable wrenches)
- 2 - 3/4 inch wrenches (or adjustable wrenches)
- 1 - Pliers (to spread cotter pin)
- 1 - Screwdriver
- 1 - Measuring tape or ruler

The figure below shows the snow thrower in the shipping carton.

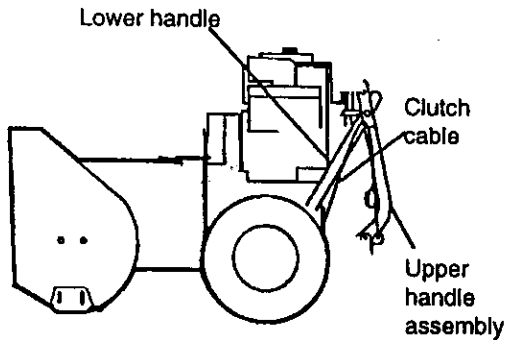

The figure below shows the snow thrower completely assembled.

References to the right or left hand side of the snow thrower are from the viewpoint of the operator's position behind the unit.

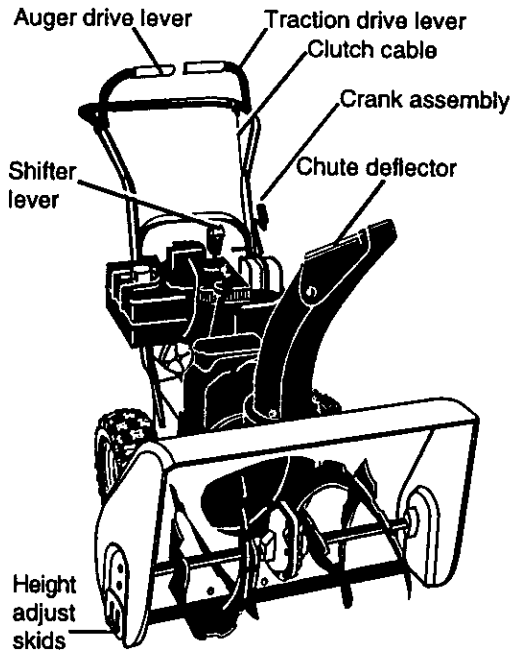

TO REMOVE SNOW THROWER FROM CARTON

- Locate and remove container of 5W30 oil.
- Locate all parts packed separately and remove from the carton.

NOTE: Place fuel stabilizer in a safe place until needed for storage.

- Remove and discard the packing material from around the snow thrower.
- Cut all four corners of the carton from top to bottom and lay the panels flat.
- Roll the snow thrower off the carton by pulling on the lower handle. **CAUTION: DO NOT** back over cables.
- Remove the packing material from handle assembly and plastic protector on top of auger housing.
- Cut ties securing the clutch control cables to the lower handle and lay cables back away from the motor frame.

TO INSTALL THE UPPER HANDLE AND CRANK ASSEMBLY

- Cut tie holding shift rod to lower handle and move shifter to the first gear.
- Loosen, but do not remove the screws, flatwashers, lockwashers and hex nuts in the upper holes of the lower handle. See figure below.

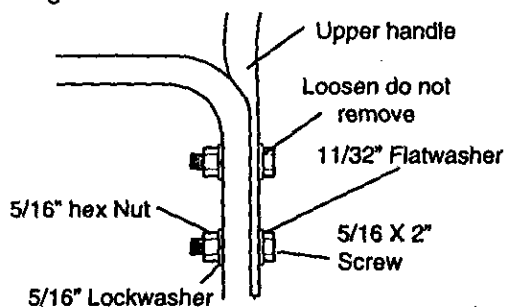

- Raise upper handle into operating position. Upper handle should be to the outside of the lower handle.

NOTE: Make sure the cables are not caught between the upper and lower handle.

NOTE: If the cables have become disconnected from the clutch levers, reinstall the cables as shown in figure below.

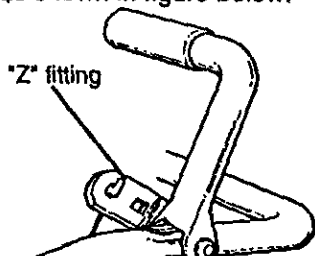

NOTE: Position cable through slots on shifter plate.

- Install hardware supplied in the parts bag (Screw, flatwasher, lockwasher, and hex nut) into middle hole on right hand side of handles. Do not tighten until all bolts are in place.
- Locate crank assembly removed earlier and remove the 3/8" nylon locknut and flatwasher from the eye bolt assembly. See figure below.
- Reinstall flatwasher and adapter. Install eye bolt through lower hole in the left hand side of the handle. See figure below.
- Install the 3/8" flatwasher and the 3/8" nylon locknut on the eye bolt as shown in figure below.

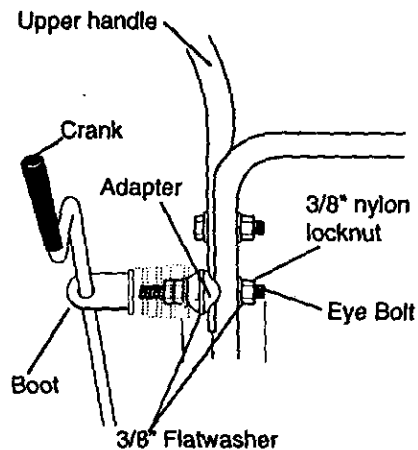

- Carefully remove cotter pin, clevis pin and universal joint pin from yoke end of crank rod assembly as shown in next figure.
- Place universal joint into end of worm gear lining up large holes. Insert universal joint pin (ensure opening in pin is in line with small openings in universal joint).
- Place yoke end of crank rod around universal joint, lining up openings. Insert clevis pin through assembly and secure with cotter pin. Spread ends of cotter pin to lock in place. See next figure.
- Tighten nut on eye bolt, keeping eye in line with the rod while tightening the inside securely.
- Tighten all handle bolts.

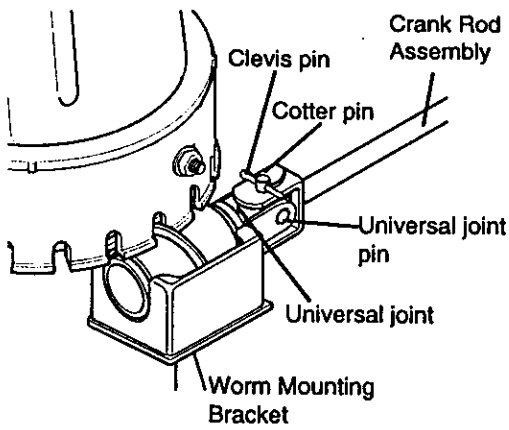

TO ASSEMBLE SNOW CHUTE

- Turn crank assembly counterclockwise until it stops.
- Locate three carriage bolts, flatwashers and nuts (found in parts bag) from snow chute flange. **DO NOT** remove carriage bolt over worm gear.
- Position snow chute on snow chute flange and align the three holes in the snow chute with holes in the snow chute flange as shown in figure below.
- Install carriage bolts from inside of chute as shown in figure below, flatwashers and nuts.
- Tighten carriage bolts securely. Be careful not to overtighten. See figure below.
- Turn crank assembly clockwise and make sure all carriage bolts are tight.

TO INSTALL SHIFTER LEVER KNOB

- Thread the hex nut found in the parts bag onto shifter lever. Thread the shifter lever knob onto the threaded end of the shifter lever until it is snug against the hex nut and the lip is pointed away from the engine. Tighten hex nut against the bottom of the shifter lever knob. See figure below.

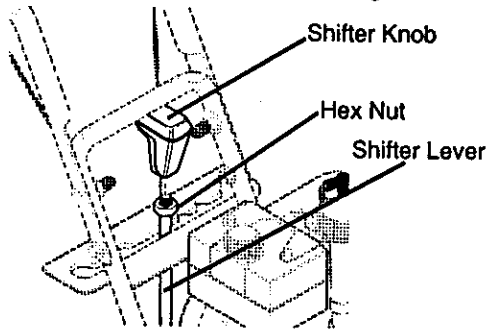

NOTE: If the cables have become disconnected, reinstall spring as shown in figure below.

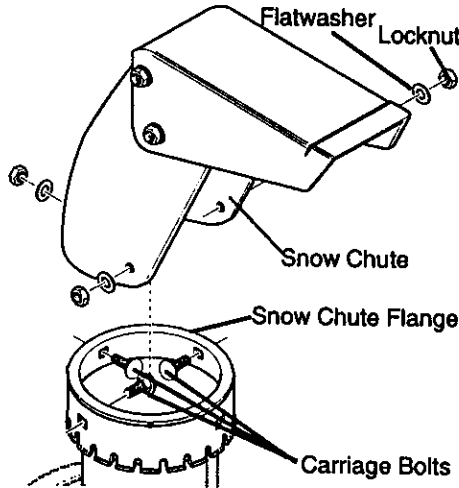
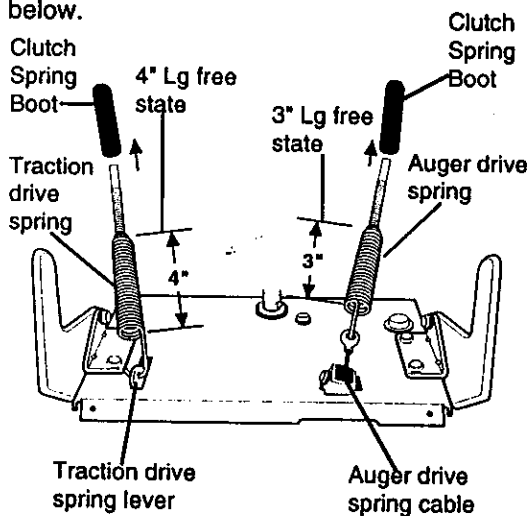

TO CHECK/ADJUST CLUTCH CONTROL CABLES

The control cables attached to the auger clutch lever and traction clutch lever as shown in figure below may need to be adjusted before you use your snow thrower.

For instructions on checking or adjusting the control cables, (See To Adjust Clutch Control Cables paragraph on page 17).

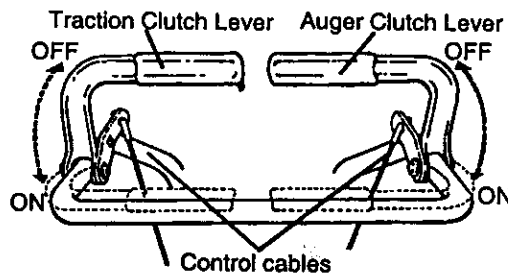

HOW TO SET UP YOUR SNOW THROWER

- Your snow thrower is equipped with height adjust skids (see second figure on page 5) on the outside of the auger housing. To adjust the skid height for different conditions, (see To Adjust Skid Height paragraph on page 17).

✓ CHECKLIST

Before you operate your new snow thrower, to ensure that you receive the best performance and satisfaction from this quality product, please review the following checklist:

- ✓ All assembly instructions have been completed.
- ✓ The discharge chute rotates freely.
- ✓ No remaining loose parts in carton.

While learning how to use your snow thrower, pay extra attention to the following important items:

- ✓✓ Engine oil is at proper level.
- ✓✓ Make sure gas tank is filled properly with clean, fresh, unleaded gasoline.
- ✓✓ Become familiar with all controls-their location and function. Operate controls before starting engine.

OPERATION

Auger Drive Lever – Starts and stops the auger and impeller (snow gathering and throwing).

Traction Drive Lever – Propels the snow thrower forward and in reverse.

Speed Shifter Lever – Selects the speed of snow thrower (6 speeds forward and 2 speeds reverse).

Crank Assembly – Changes the direction of snow throwing through the discharge chute.

Chute Deflector – Changes the distance the snow is thrown.

Discharge Chute – Changes the direction the snow is thrown.

Height Adjust Skids – Adjusts the ground clearance of the auger housing.

Ignition Key – Must be inserted to start the engine.

Recoil Starter Handle – Starts the engine manually.

Choke Control – Used to start a cold engine.

Primer Button – Injects fuel directly into the carburetor manifold for fast starts in cold weather.

Throttle Control – Controls the engine speed.

Electric Starter Button – Used to start the engine using the 120 V electric starter.

Shear Bolt – Shear bolts are designed to break (to protect the machine) if an object becomes lodged in the auger housing. Use of a harder bolt will destroy the protection provided by the shear bolt.

Toolbox- Spare shear pins and spacers are located in toolbox.

KNOW YOUR SNOW THROWER

READ THIS OWNER'S MANUAL AND SAFETY RULES BEFORE OPERATING YOUR SNOW THROWER. Compare the illustrations with your SNOW THROWER to familiarize yourself with the location of various controls and adjustments. Save this manual for future reference.

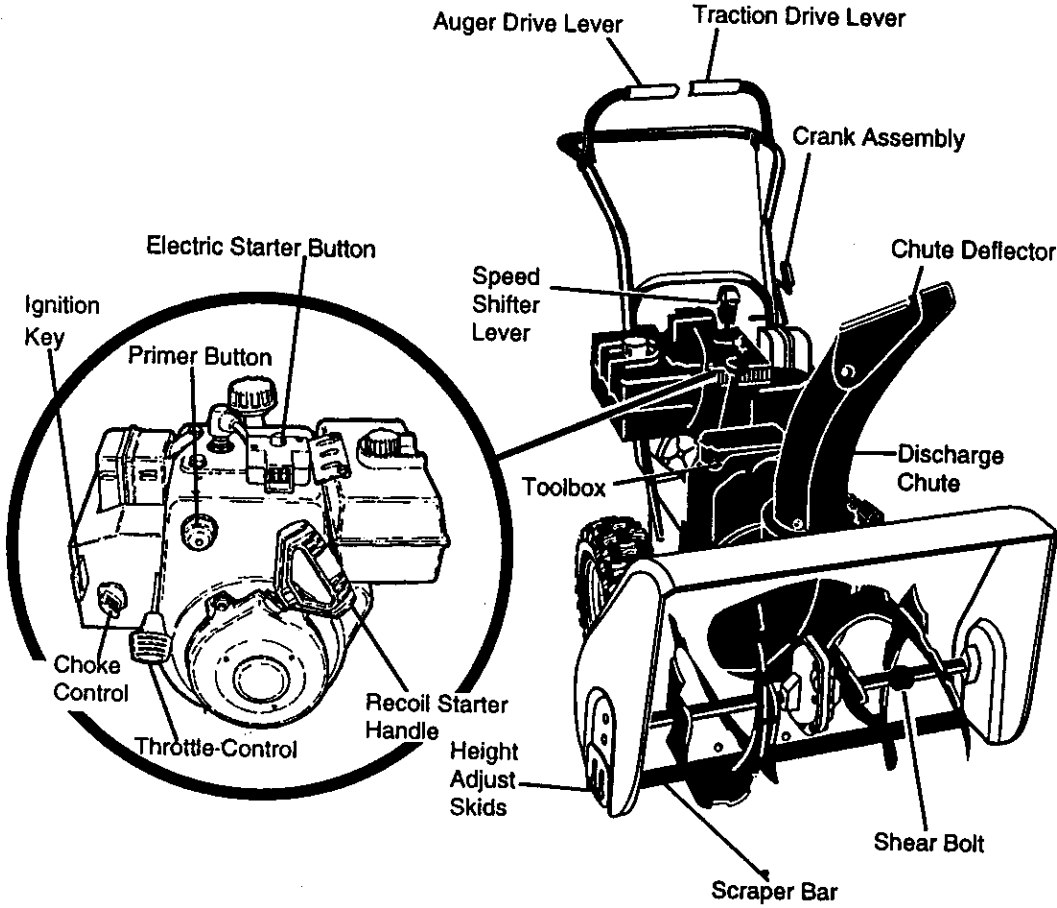
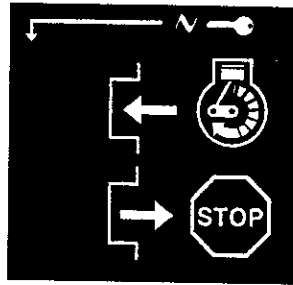
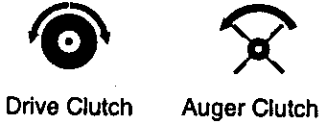
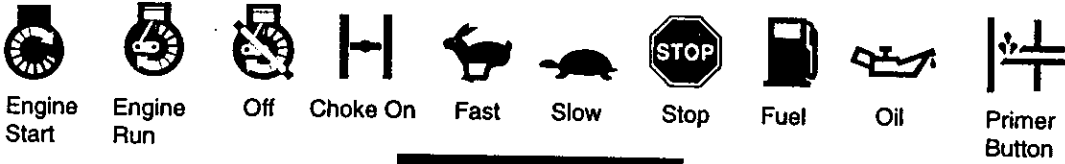

The operation of any snow thrower can result in foreign objects being thrown into the eyes, which can result in severe eye damage. Always wear safety glasses or eye shields while operating the snow thrower.

We recommend standard safety glasses or a wide vision safety mask for over your glasses, available at Craftsman Retail Stores or Service Centers.

⚠ CAUTION: Read owner's manual before operating machine. Never direct discharge toward bystanders. Release the auger control bar and stop the engine before unclogging discharge chute or auger housing and before leaving the machine.

HOW TO USE YOUR SNOW THROWER

TO STOP YOUR SNOW THROWER

- To stop throwing snow, release the auger drive lever (see last figure on this page).
- To stop the wheels, release the traction drive lever (see last figure on this page).
- To stop the engine, push the throttle control lever to off and pull out (DO NOT TURN) the ignition key, see figure below.

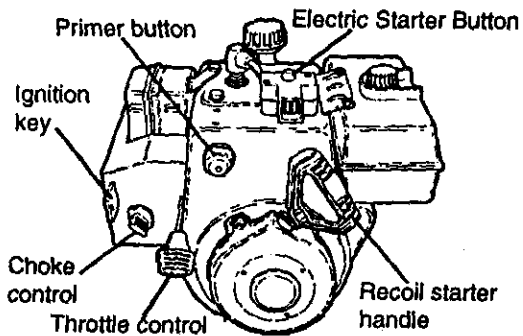

TO CONTROL SNOW DISCHARGE

- Turn the crank assembly to set the direction of the snow throwing.
- Loosen the wing knob on the chute deflector and move the deflector to set the distance. Move the deflector (UP) for more distance, (DOWN) for less distance. Then tighten the wing knob, see figure below.

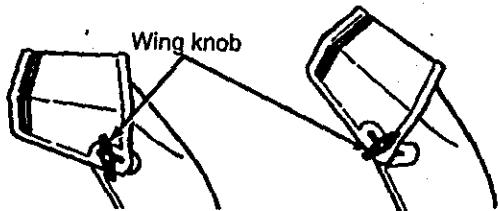

TO MOVE FORWARD AND BACKWARD

- To shift, release the traction drive lever and move the speed shifter lever to the speed you desire. Ground speed is determined by snow conditions. Select the speed you desire by moving the speed shifter lever into the appropriate area on the speed selector.

Speeds 1, 2 - Wet, Heavy, Extra Deep

Speed 3 - Light

Speed 4 - Very Light

Speeds 5, 6 - Transport only

- Engage the traction drive lever as shown in figure below, left hand. As the snow thrower starts to move, maintain a firm hold on the handles, and guide the snow thrower along the clearing path. Do not attempt to push the snow thrower.
- To move the snow thrower backward, move the speed shifter lever into first or second reverse and engage the traction drive lever (left hand).

IMPORTANT: Never move the speed shifter lever while the traction lever is down.

TO THROW SNOW

- Push down the auger drive lever, see figure below.
- Release to stop throwing snow.

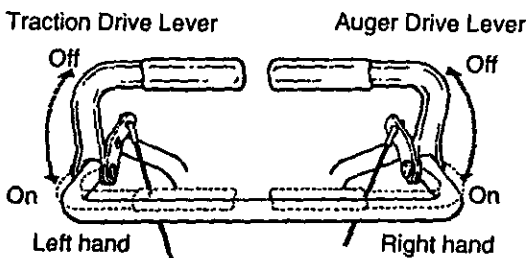

TO USE WHEEL LOCKOUT PIN

- The left hand wheel is secured to the axle with a klick pin see figure below. This unit was shipped with this klick pin in the locked position (klick pin through hole in wheel).

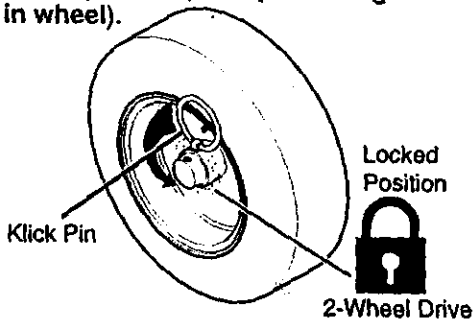

- For ease of maneuverability in light snow conditions, disconnect the klick pin from the wheel locked position and push into the single wheel drive (klick pin through axle hole only) position (see figure below).
- Make sure that the klick pin is in the single wheel drive position of the axle only and not through the locked position.

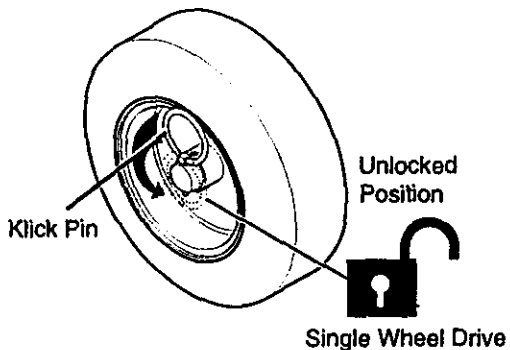

BEFORE STARTING THE ENGINE

FILL OIL

NOTE: Engine may already contain some residual oil. Check frequently when filling the crankcase. Do not over fill. This snow thrower was shipped with a container of 5W30 motor oil. This oil must be added to the engine before operating. Remove the oil fill cap/dipstick and fill the crank case to (FULL) line on dipstick (26 ounces) (see next figure).

Tighten the fill cap/dipstick securely each time you check the oil level.

For extreme cold operating conditions of 0°F and below, use a partial synthetic 0W30 motor oil for easier starting.

NOTE: S.A.E. 5W30 motor oil may be used to make starting easier in areas where the temperature is 20° F. or lower.

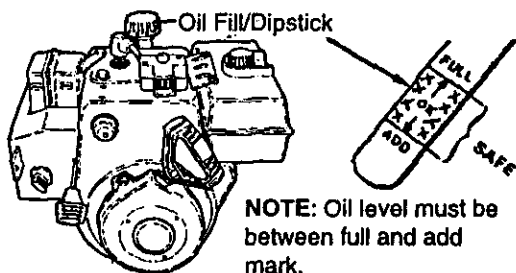

NOTE: Oil level must be between full and add mark.

FILL GAS

NOTICE: ENGINES WHICH ARE CERTIFIED TO COMPLY WITH CALIFORNIA AND US EPA EMISSION REGULATIONS FOR ULGE ENGINES: Are certified to operate on regular unleaded gasoline. Include the following emission control system(s): EM, TWC (if so equipped). Include any user adjustable features - therefore no other adjustments are needed.

WARNING: Experience indicates that alcohol blended fuels (called gasohol or those using ethanol or methanol) can attract moisture which leads to separation and formation of acids during storage. Acidic gas can damage the fuel system of an engine while in storage.

To avoid engine problems, the fuel system should be emptied before storage for 30 days or longer. Start the engine and let it run until the fuel lines and carburetor are empty. Use the carburetor bowl drain to empty residual gasoline from the float chamber. Use fresh fuel next season (see Storage instructions on page 22 for additional information).

Never use engine or carburetor cleaner products in the fuel tank or permanent damage may occur.

Fill the fuel tank with a fresh, clean, unleaded regular, unleaded premium, or reformulated automotive gasoline only. DO NOT use leaded gasoline. Be sure that the container you pour the gasoline from is clean and free from rust or other foreign particles. Never use gasoline that may be stale from long periods of storage in the container.

CAUTION: Gasoline is flammable and caution must be used when handling or storing it.



Do not fill fuel tank while snow thrower is running, when it is hot, or when snow thrower is in an enclosed area.

Keep away from open flame or an electrical spark and DO NOT SMOKE while filling the fuel tank.

NEVER fill the tank completely. FILL THE TANK to within 1/4" - 1/2" from the top to provide space for expansion of fuel.

Always fill fuel tank outdoors and use a funnel or spout to prevent spilling.

COLD START

- Be sure the auger drive and traction drive levers are in the disengaged (released) position.
- Move the throttle control to  (FAST) position. See figure on page 9 for location.
- Remove the keys from the plastic bag. Insert one key into the ignition slot. Be sure it snaps into place. **DO NOT TURN KEY.** Keep the second key in a safe place.
- Rotate the choke knob clockwise to  choke ON position. See figure on page 9.
- Push the primer button, see figure on page 9, while covering the vent hole as follows: (Remove finger from primer button between primes).

Do not prime if temperature is above 50°F.

Two times if temperature is 50°F to 15°F.

Four times if temperature is below 15°F.

- Pull the recoil starter handle rapidly. Do not allow the handle to snap back, but allow it to rewind slowly while keeping a firm hold on the starter handle.
- As engine starts warm up move choke lever to "1/2 choke" position. When engine runs smoothly, move choke lever to "No Choke" Position

NOTE: Allow the engine to warm up for several minutes before blowing snow in temperatures below 0°F.

- Run the engine at full throttle  (FAST) when throwing snow.

WARM START

If restarting a warm engine after a short shutdown, leave choke at (OFF) and do not push the primer button. If the engine fails to start, follow the Cold Start instructions above.

FROZEN RECOIL STARTER

If the starter is frozen and will not turn engine:

- Pull as much rope out of the starter as possible.
- Release the starter handle and let it snap back against the starter.

If the starter still fails to turn engine, repeat the two previous steps until the starter engages. Then continue with the directions for cold start.

To help prevent possible freeze-up of recoil starter and engine controls, proceed as follows after each snow removal job.

- **With the engine running**, pull the starter rope hard with a continuous full arm stroke three or four times. Pulling of starter rope will produce a loud clattering sound. This is not harmful to the engine or starter.
- **With the engine not running**, wipe all snow and moisture from the carburetor cover in area of control levers. Also move throttle control, choke control, and starter handle several times.

 **CAUTION:** Never run engine indoors or in enclosed, poorly ventilated areas. Engine exhaust contains CARBON MON-OXIDE, AN ODORLESS AND DEADLY GAS. Keep hands, feet, hair and loose clothing away from any moving parts on engine and snow thrower.

WARNING: Temperature of muffler and nearby areas may exceed 150° F. Avoid these areas.

DO NOT allow children or young teenagers to operate or be near snow thrower while it is operating.

 **CAUTION:** Do not attempt to remove any item that may become lodged in auger without taking the following precautions:

- Release auger drive and traction drive levers.
- Move throttle lever to stop position.
- Remove (DO NOT TURN) ignition key.
- Disconnect spark plug wire.
- Do not place your hands in the auger or discharge chute. Use a pry bar.

SNOW THROWING TIPS

- For maximum snow thrower efficiency in removing snow, adjust ground speed, **NEVER** the throttle. Go slower in deep, freezing, or wet snow. If the tracks slip, reduce forward speed. The engine is designed to deliver maximum performance at full throttle and should be run at this power setting at all times. Most efficient

snow blowing is accomplished when the snow is removed immediately after it falls.

- For complete snow removal, slightly overlap each path previously taken. Use more overlap in deep snow to prevent overloading.
- The snow should be discharged down wind whenever possible. In windy conditions, lower the chute deflector to direct discharged snow close to the ground, where it is less likely to blow into unwanted areas.
- For normal usage, set the skids so that the scraper bar is 1/8" above the skids. For extremely hard-packed snow surfaces, adjust the skids upward so that the scraper bar touches the ground.
- On gravel or crushed rock surfaces, set the skids at 1-1/4" below the scraper bar (See To Adjust Skids Height paragraph on page 17). Stones and gravel must not be picked up and thrown by the machine.
- After the snow throwing job has been completed, allow the engine to idle for a few minutes, which will melt snow and accumulated ice off the engine.
- Clean the snow thrower thoroughly after each use.
- Remove ice and snow accumulation and all debris from the entire snow thrower, and flush with water (if possible) to remove all salt or other chemicals. Wipe snow thrower dry.

PRODUCT SPECIFICATIONS

HORSE POWER:	8.5 HP
DISPLACEMENT:	19.34 cu. in.
GASOLINE CAPACITY:	4 quart (unleaded)
OIL (26 oz. Capacity) :	5W-30
SPARK PLUG:	Champion RJ19LM (Gap .030) or Equivalent
VALVE CLEARANCE:	Intake: .010 In. Exhaust: .010 In.

MAINTENANCE

CUSTOMER RESPONSIBILITIES

SERVICE RECORDS Fill in dates as you complete regular service	SCHEDULE							SERVICE DATES			
	After first 2 Hours	Before Each Use	As Needed	Every 10 Hours	Every 25 Hours	Each Season	Before Storage				
Check Engine Oil Level		✓				✓					
Change Engine Oil					✓	✓					
Tighten all screws and nuts	✓	✓	✓								
Check Traction Clutch Cable Adjustment (See cable Adj)	✓					✓					
Replace Spark Plug					✓	✓					
Check Drive Belts						✓					
Lubricate all pivot points				✓			✓				
Drain Fuel							✓				
Check Auger Clutch Cable Adjustment (See Cable Adj)	✓					✓					
Lubricate Disc Drive Plate Zerk					✓		✓				

GENERAL RECOMMENDATIONS

The warranty on this snow thrower does not cover items that have been subjected to operator abuse or negligence. To receive full value from the warranty, the operator must maintain the snow thrower as instructed in this manual. The maintenance chart is provided to assist the operator in properly maintaining the snow thrower.

Some adjustments will need to be made periodically to properly maintain your snow thrower.

AFTER FIRST USE

- Check for any loose or damaged parts.
- Tighten any loose fasteners.
- Check and maintain the auger.
- After each use, remove all snow and slush off the snow thrower to prevent freezing of auger or controls.
- Check controls to make sure they are functioning properly.
- If any parts are worn or damaged, replace immediately.

LUBRICATION CHART

Lubricate Disc Drive Plate Zerk with a Hi Temp EP Moly Grease.

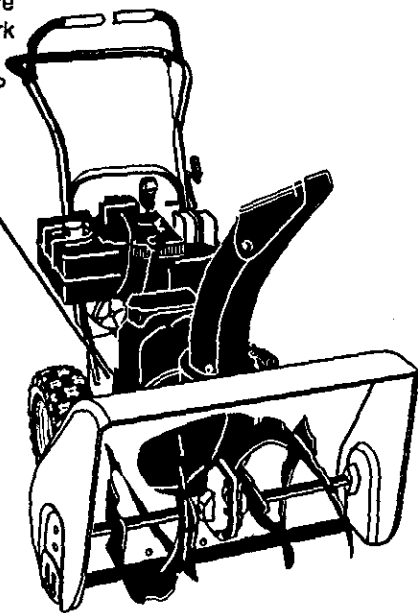

SNOW THROWER

LUBRICATION - EVERY 25 HOURS

- Lubricate Disc Drive Plate every twenty-five (25) hours and at the end of the season and/or before storage.

To Lubricate:

- Position speed selector lever in first gear.
- Stand the snow thrower up on the auger housing end.
- Remove the bottom panel (see second figure on page 19).

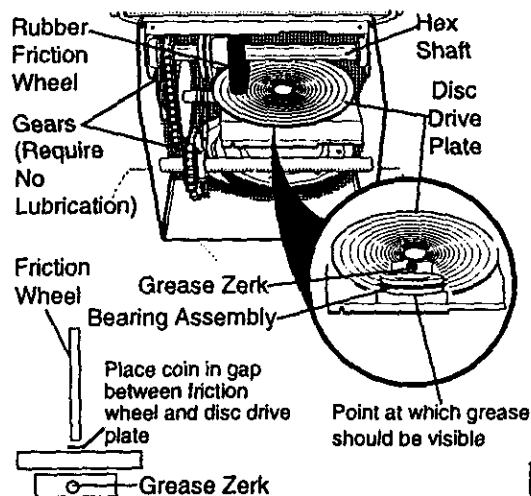

- Turn disc drive plate clockwise by hand until grease zerk is clearly visible at front center. See figure below.
- Place a coin or (a shim of equal thickness) between the rubber friction wheel and disc drive plate to prevent rubber friction wheel contacting the drive disc.
- To grease zerk, use a hand grease gun, lubricate with a Hi Temp EP Moly grease. See inset of second figure on this page. **DO NOT** over fill or allow grease to come in contact with the disc drive plate or friction wheel or damage will result. Fill zerk only until grease becomes visible below bearing assembly located under grease zerk. See insert in figure above.

IMPORTANT: Remove coin and ensure that a gap exists between friction wheel and disc drive plate.

NOTE: Clean all excess grease found on friction disc hub.

CAUTION: Do not allow grease to contact friction wheel and disc drive plate.

LUBRICATION

- Hex Shaft and Gears - Hex shaft and gears require no lubrication. All bearings and bushings are lifetime lubricated and require no maintenance.

NOTE: Any greasing or oiling of the above components can cause contamination of the friction wheel. If the disc drive plate or friction wheel comes in contact with grease or oil, damage to the friction wheel will result.

Should grease or oil come in contact with the disc drive plate or friction wheel, be sure to clean the plate and wheel thoroughly.

NOTE: For storage, the hex shaft and gears should be wiped with 5W-30 motor oil to prevent rusting. See figure above.

- Auger Gear Box - The auger gear box has been factory lubricated for life. If for some reason lubricant should leak out, have auger gear case checked by a competent repairman.

ENGINE

LUBRICATION

Check the crankcase oil level (see figure below) before starting the engine and after each five (5) hours of continuous use. Add S.A.E. 5W30 motor oil as needed. Tighten fill cap/dipstick securely each time you check the oil level.

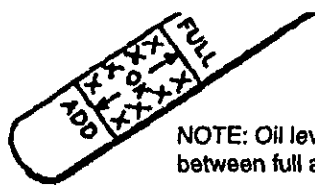

NOTE: Oil level must be between full and add mark

OIL RECOMMENDATION

Only use high quality detergent oil rated with API service classification SG. Select the oil's viscosity grade according to your expected operating temperature:

NOTE: For extreme cold operating conditions of 0° and below, use a partial synthetic 0W30 motor oil for easier starting.

NOTE: Although multi-viscosity oils improve starting in cold weather, these multi-viscosity oils will result in increased oil consumption when used above 32°F. Check your engine oil level more frequently to avoid possible engine damage from running low on oil.

Change the oil every 25 hours and at the beginning of each season.

- Position the snow thrower so that the oil drain plug is at the lowest point on the engine. Remove the oil drain plug and the oil fill cap/dipstick. Drain the oil into a suitable container. Oil will drain more freely when warm.
- Replace the oil drain plug and tighten securely.

SPARK PLUG

- Make sure that the spark plug is tightened securely into the engine and the spark plug wire is attached to the spark plug.
- If a torque wrench is available, torque plug to 18 to 23 foot pounds.
- Clean the area around the spark plug base before removal to prevent dirt from entering the engine.
- Clean the spark plug and reset the gap periodically at .030 inch.

SERVICE AND ADJUSTMENTS

⚠ CAUTION: Always disconnect the spark plug wire and tie back away from the plug before making any adjustments or repairs.

TO ADJUST SKID HEIGHT

This snow thrower is equipped with two height adjustment skids, located on the outside of the auger housing (see figure below). These skids elevate the front of the snow thrower.

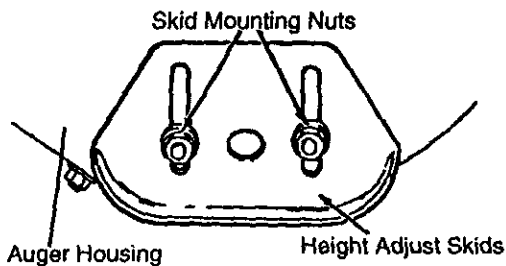

For normal hard surfaces, adjust the skids as follows:

- Check tire pressure (14 to 17 pounds).
- Place the extra shear bolts supplied (found in parts bag) under each end of the scraper bar near but not under the skid.
- Loosen the skid mounting nuts (see figure above) and adjust the skids up to bring the front of the snow thrower down. Retighten the mounting nuts.
- Set the skid on the other side at the same height.

For rocky or uneven surfaces, adjust the skids as follows:

- Raise the front of the snow thrower by moving the skids down. This will help prevent rocks and other debris from being picked up and thrown by the auger.

TO ADJUST SCRAPER BAR

After considerable use, the metal scraper bar will have a definite wear pattern. The scraper bar may have to be returned to its original lower setting to maintain the original performance level. To adjust:

- Position the snow thrower on a level surface.
- Make sure both tires are equally inflated. Proper tire pressure is 14 to 17 PSI. See side of tire for maximum inflation. Do not exceed sidewall maximum pressure on tire.

- Loosen the carriage bolts and nuts securing the scraper bar to the auger housing.
- Adjust the scraper bar to the proper position.
- Tighten the carriage bolts and nuts, making sure that the scraper bar is parallel with the working surface.
- For extended operation, the scraper bar may be reversed. If the scraper bar must be replaced due to wear, remove the carriage bolts and nuts and install a new scraper bar.

CAUTION: Be certain to maintain proper ground clearance for your particular area to be cleared. Objects such as gravel, rocks or other debris, if struck by the impeller, may be thrown with sufficient force to cause personal injury, property damage or damage to the snow thrower.

TO ADJUST THE CLUTCH CONTROL CABLES

Periodic adjustment of the cables may be required due to normal stretch and wear on the belts. To check for correct adjustment, the control lever must be in the full forward position, resting on the plastic bumper. The control cables are correctly adjusted when the center of the "Z" fitting is in the center of the hole and there is no droop in the cable. See figure below.

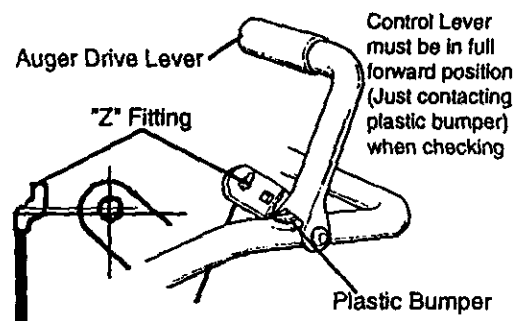

If adjustment is necessary:

- Remove fuel from tank, and stand blower on end.
- Disconnect the "Z" fitting from drive lever.
- Pull rubber boot off the top of the spring. Push the cable through the spring (see first figure on page 18) to expose the threaded portion of the cable.

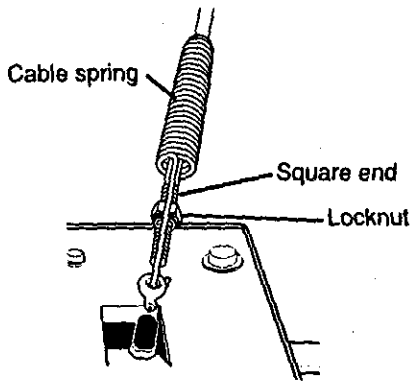

- Hold the square end of the threaded portion with pliers and adjust the locknut in or out until the excess slack is removed.
- Pull the cable back through the spring and connect the cable. Do the same for the other lever cable, if needed.

NOTE: Whenever the traction drive or auger belts are adjusted or replaced, the cables will need to be adjusted.

TO ADJUST BELTS

AUGER DRIVE BELT

If your snow thrower will not discharge snow, check the control cable adjustment. If it is correct, then check the condition of the auger drive belt. It may be loose or damaged. If it is damaged, replace it (see To Replace Belts on this page).

TRACTION DRIVE BELT

The traction drive belt (see second figure on this page) has constant spring pressure and does not require adjustment.

- Replace the traction drive belt if it is slipping (see To Replace Belts paragraph on page 18).

TO REPLACE BELTS

The drive belts on this snow thrower are of special construction and should be replaced with original equipment belts available from your nearest Craftsman Store or Service Center.

You will need the assistance of a second person while replacing the belts.

Drain the gasoline from the fuel tank by removing the fuel line at the carburetor. Drain the gas into a container and reinstall the fuel line.

CAUTION: Drain the gasoline outdoors, away from fire or flame.

AUGER DRIVE BELT

If your snow thrower will not discharge snow, and the auger drive belt (see figure below) is damaged, replace it as follows:

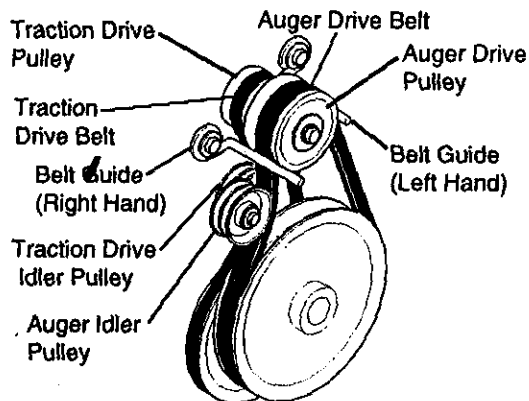

- Disconnect the spark plug wire.
- Remove the belt cover (see figure below).

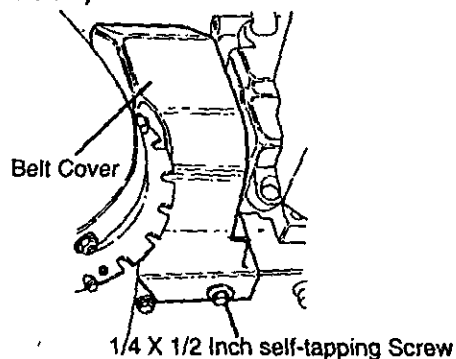

- Loosen the belt guides (see first figure this column) and pull away from the engine drive pulley.
- Loosen nut on the auger idler pulley (see first figure, this column) and pull idler pulley away from the belt.
- Remove top two bolts that secure auger housing to motor mount frame. Loosen bottom two bolts. Auger housing and motor mount frame will separate, hinged by bottom two bolts.
- Remove old belt from the auger drive pulley.
- Install the original equipment replacement belt in reverse order of removal.
- Position drive belt onto the auger drive pulley.
- Adjust the belt guides (see To Adjust The Belt Guides paragraph on page 19).
- Reinstall the belt cover.

- Check clutch control cable adjustment, see page 17.
- Reconnect spark plug wire.

TRACTION DRIVE BELT

If your snow thrower will not move forward, check the traction drive belt (see second figure on page 18) for wear (Check other causes also in the Trouble Shooting Points section). If the traction drive belt needs to be replaced, proceed as follows:

- Disconnect the spark plug wire.
- Remove the belt cover (see last figure on page 18).
- Loosen the belt guides and pull away from engine drive pulley (see first figure).
- Loosen nut on auger idler and pull auger idler pulley away from belt. Note location of idler pulley for later re-installation.
- Remove auger drive belt from engine pulley.
- Pull the idler pulley away from the drive belt, allowing belt to be positioned onto engine pulley.
- Release idler pulley. Ensure idler pulley is properly engaged with belt.
- Reinstall auger drive belt.
- Adjust belt guides (see To Adjust The Belt Guides paragraph below).
- Adjust idler on auger belt.
- Reinstall the belt cover.
- Reconnect the spark plug wire.

TO ADJUST THE BELT GUIDES

After you replace the traction or auger drive belt, you need to adjust one or both of the belt guides. Proceed as follows:

- Disconnect the spark plug wire.
- Remove the belt cover (See last figure on page 18).
- Engage the auger drive clutch lever.
- Measure the distance between the belt guides and the belt (See next figure). The distance should be 3/32" for each guide.
- If adjustment is necessary, loosen the belt guide mounting bolts. Move the belt guides to the correct position. Tighten the mounting bolts.
- Reinstall the belt cover.
- Reconnect the spark plug wire.

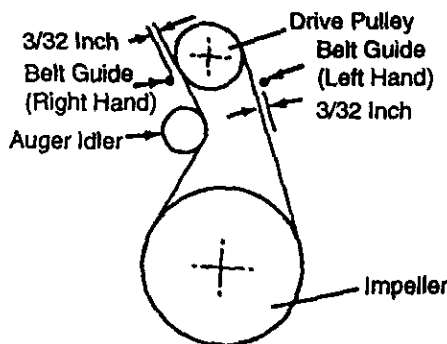

TO ADJUST THE FRICTION WHEEL

If the snow thrower will not move forward, you need to check the traction drive belt, the traction drive cable or the friction wheel. If the friction wheel is damaged, it will need to be replaced (see the To Replace Friction Wheel paragraph on page 20). If the friction wheel is not worn, check the adjustment, as follows:

- Disconnect the spark plug wire.
- Drain the gasoline from the gas tank.
- Stand snow thrower on the auger housing end.
- Remove the bottom panel (see figure below).

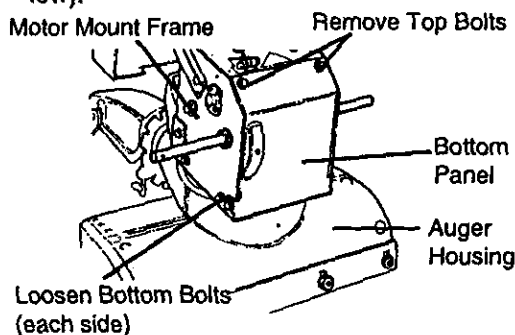

- Position the shifter lever in first (1) gear.
- Note the position of the friction wheel on the disc drive plate. The right outer side of the disc drive plate should be 3" from the center of the friction wheel (See figure below).

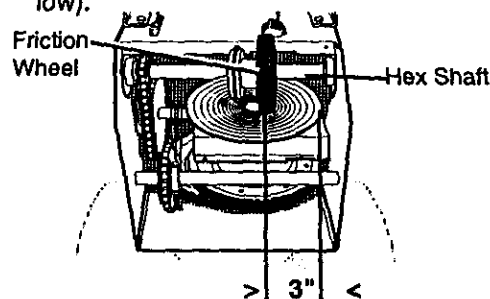

If adjustment is necessary:

- Loosen bolts in speed selector lever (see figure below).

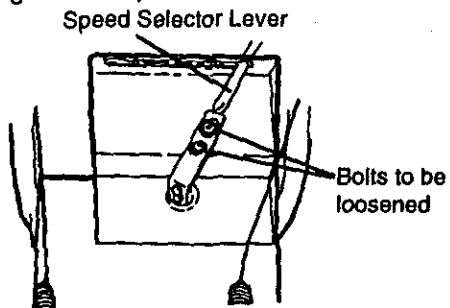

TO REPLACE FRICTION WHEEL

If the snow thrower will not move forward, and the friction wheel is worn or damaged, you need to replace it as follows: (First allow the engine to cool).

- Drain the gasoline from the fuel tank.
- Drain the fuel in a container and reinstall the fuel line.
- Disconnect the spark plug wire.
- Stand the snow thrower up on the auger housing end (see figure below).

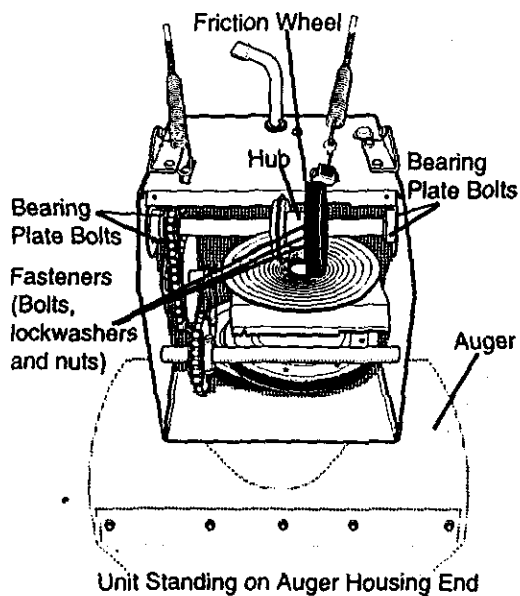

- Remove the bottom panel (see second figure on page 19).
- Remove the three (3) fasteners securing the friction wheel to the hub (see second figure above).
- Remove the four bolts securing the bearing plates (both sides), (see second figure above).

- Remove right side bearing plate. Leave hex shaft in original position.
- Remove friction wheel from hub. Slip friction wheel off hex shaft towards right side. See figure below.

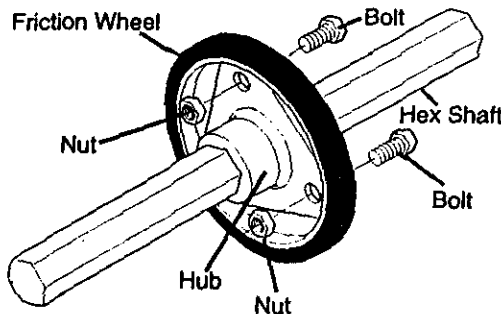

TO REPLACE AUGER SHEAR BOLT

The augers are secured to the auger shaft with special bolts (see figure below) that are designed to break (to protect the machine) if an object becomes lodged in the auger housing. Use of a harder bolt will destroy the protection provided by the shear bolt.

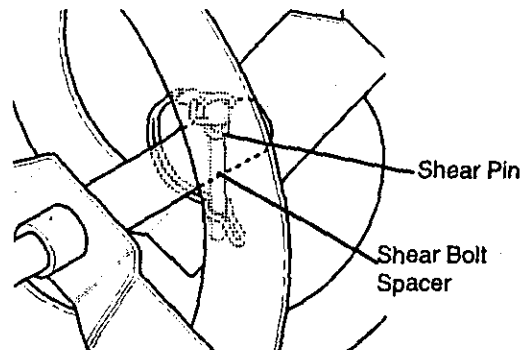

IMPORTANT: To ensure safety and performance levels, only original equipment shear bolts should be used. When replacing shear bolts, be sure to replace shear bolt spacers. To replace a broken shear bolt, proceed as follows:

- Move the throttle to **STOP** (STOP) and turn off all controls.
- Disconnect the spark plug wire. Be sure all moving parts have stopped.
- Align the hole in the auger tube with the hole in the auger shaft. Install the new shear pin and shear bolt spacer found in toolbox on top of belt cover.

NOTE: Spacer fits inside the larger hole in the auger tube.

- Reconnect the spark plug wire.

TO ADJUST CARBURETOR

If you think your carburetor needs adjusting, see your nearest Authorized Craftsman Service Center. Engine performance should not be affected at altitudes up to 7,000 feet. For operation at higher elevations, contact your Authorized Craftsman Service Center. **IMPORTANT:** Never tamper with the engine governor, which is factory set for proper engine speed. Overspeeding the engine above the factory high speed setting can be dangerous. If you think the engine-governed high speed needs adjusting, contact your nearest Craftsman Service Center, which has the proper equipment and experience to make any necessary adjustments.

TO ADJUST OR REPLACE THE SPARK PLUG

NOTICE: This spark ignition system meets all requirements of the Canadian Interference-Causing Equipment Regulations.

NOTICE: This engine complies with all current Australian and New Zealand limitations regarding electromagnetic interference. If you have difficulty starting your snow thrower, you may need to adjust or replace the spark plug. Follow the instructions below.

Replace the spark plug if the electrodes are pitted or burned or if the porcelain is cracked.

TO ADJUST:

- Clean the spark plug by carefully scraping the electrodes (do not sand blast or use a wire brush).
- Be sure the spark plug is clean and free of foreign material. Check the electrodes gap (see figure below) with a wire feeler gauge and reset the gap to .030 inch if necessary.

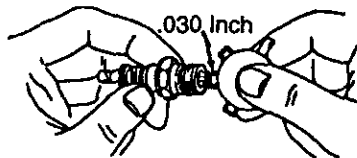

TO REPLACE:

- If you need a new spark plug, use only the proper replacement spark plug (See page 14).
- Set the gap to .030 inches.
- Before installing the spark plug, coat its threads lightly with oil or grease to insure easy removal.
- Tighten the plug firmly into the engine.
- If a torque wrench is available, torque the plug to 18 to 23 ft. - lbs.

TROUBLE SHOOTING

TROUBLE	CAUSE	CORRECTION
Difficult starting	Defective spark plug Water or dirt in fuel system	Replace defective plug Use carburetor bowl drain to flush and refill with fresh fuel
Engine runs erratically	Blocked fuel line or low on fuel	Clean fuel line; check fuel supply; add fresh gasoline (gasoline/oil mixture if 2-cycle engine)
Engine stalls	Unit running on CHOKE	Move choke lever to OFF position
Engine runs erratically; or Loss of power	Water or dirt in fuel system	Use carburetor bowl drain to flush and refill with fresh fuel
Excessive vibration	Loose parts; damaged impeller	Stop engine immediately and disconnect spark plug wire. Tighten all bolts and make all necessary repairs. If vibration continues, have the unit serviced by a Craftsman service repairman
Units fails to propel itself	Drive belt loose or damaged Incorrect adjustment of auger control cable Worn or damaged friction wheel	Replace drive belt Adjust traction drive cable Repair friction wheel
Unit fails to discharge snow	Auger drive belt loose or damaged Auger control cable not adjusted correctly Shear bolt broken Discharge chute clogged Foreign object lodged in auger	Replace auger belt Adjust auger control cable Replace with shear pin located in tool box on belt cover. Stop engine immediately and disconnect spark plug wire. Clean discharge chute and inside of auger housing. Stop engine immediately and disconnect spark plug wire. Remove object from auger.

CRAFTSMAN 26" - 8.5H.P. SNOW THROWER 536.886190
ELECTRIC START ASSEMBLY

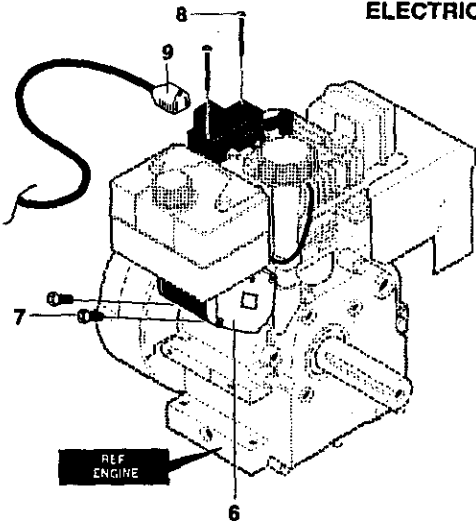

REF NO.	PART NO.	PART NAME
6	6218	Motor, Electric Starter
7	6216	Screw, 1/4-20x.50
8	6217	Screw #6-32x2.50
9	6219	Cord, Starter Motor
	761301	Owner's Manual Eng/Sp

319051B

ENGINE ASSEMBLY

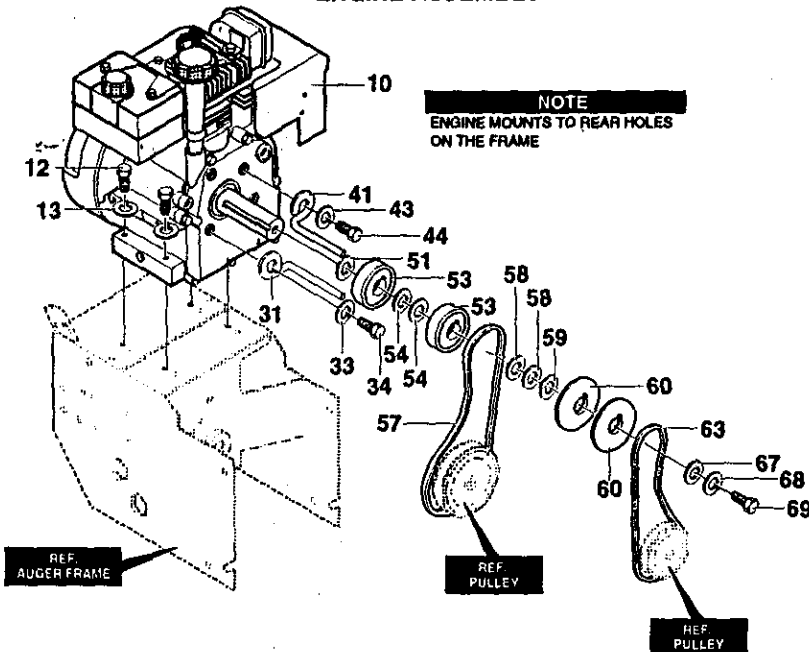

NOTE
 ENGINE MOUNTS TO REAR HOLES
 ON THE FRAME

319042G

REF NO.	PART NO.	PART NAME
10	ENGINE	Model 143.988003 (See Engine pages)
12	710024	Screw, 5/16-18
13	120638	Washer, Hvsptlk
31	3949	Guide, Rod Belt RH
33	120638	Washer, Hvsptlk
34	.910828	Screw, 5/16-24x.625
41	3949	Guide, Rod Belt LH
43	120638	Washer, Hvsptlk
44	910828	Screw, 5/16-24x.625
51	579855	Washer, Crankshaft

REF NO.	PART NO.	PART NAME
53	579854	Pulley Half V3L
54	579861	Flatwasher, 752x.91x.02
57	579932	Belt, V 3L 33.13Lg
58	73840	Flatwasher .765x1.12x.06
59	586251	Spacer, Sleeve
60	586253	Pulley, Engine
63	581264	Belt, V 4L
67	313826	*Flatwasher
68	120382	Washer, Regsptlk
69	39573	Screw, 3/8-24x1.00

Note: Always use original equipment parts. Use of service/replacement parts other than original parts may void your warranty.

All unnumbered items are interchangeable with opposite side

CRAFTSMAN 26" - 8.5H.P. SNOW THROWER 536.886190

FRAME ASSEMBLY

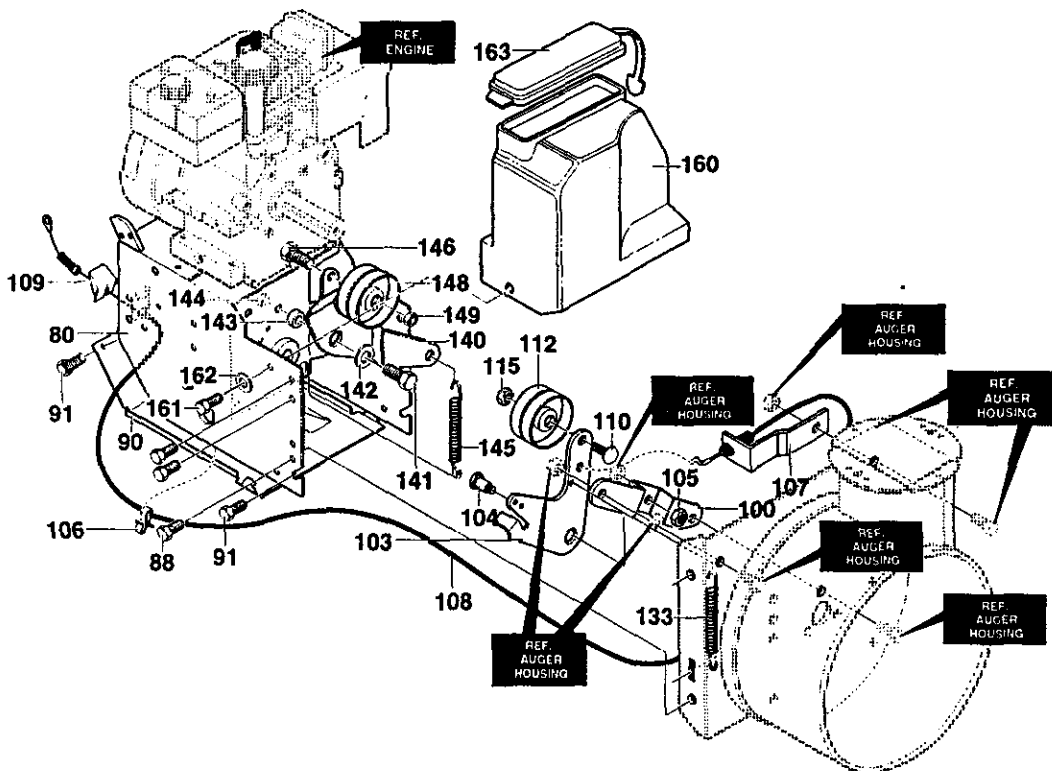

342573A

REF. NO.	PART NO.	PART NAME	REF. NO.	PART NO.	PART NAME
80	340578-833	Frame Assembly	133	313854	Spring, Tension Return
88	780055	Screw, 5/16-18x.50 Tap.	140	579872	Lever, Idler Arm Traction
90	583031-853	Panel, Bottom	141	180077	Screw, 5/16-18x.75
91	310169	Screw, 1/4-20x.63 Tap.	142	73795	Flatwasher .328x.125x.075
100	761195	Plate, Clutch Arm Mtg.	143	579865	Bushing, Idler Lever
103	761198	Arm-Clutch	144	71038	Nut, 5/16-18 Hexctrkjam
104	710200	Bolt, 3/8-16 Shoulder	145	313854	Idler Spring
105	41529	Nut, 3/8-16 Hxctrkjam	146	180124	Screw, 3/8-16x1.25
106	340682	Clip, Cable	148	313843	Idler Pulley
107	340579	Bracket, Compact CableMtg	149	41529	Nut, 3/8-16 Hexctrkjam
108	761153	Cable, Auger Clutch Cont.	160	760478	Belt Cover w/ Storage
109	340869	Shield, Cable	161	310169	Screw, 1/4-20x.63 Tap
110	180124	Screw, 3/8-16x1.25	162	120392	Flatwasher .281x.63x.065
112	313843	Idler Pulley	163	760539	Lid, Belt Cover
115	41529	Nut, 3/8-16 Hxctrkjam			

CRAFTSMAN 26" - 8.5H.P. SNOW THROWER 536.886190

DRIVE ASSEMBLY

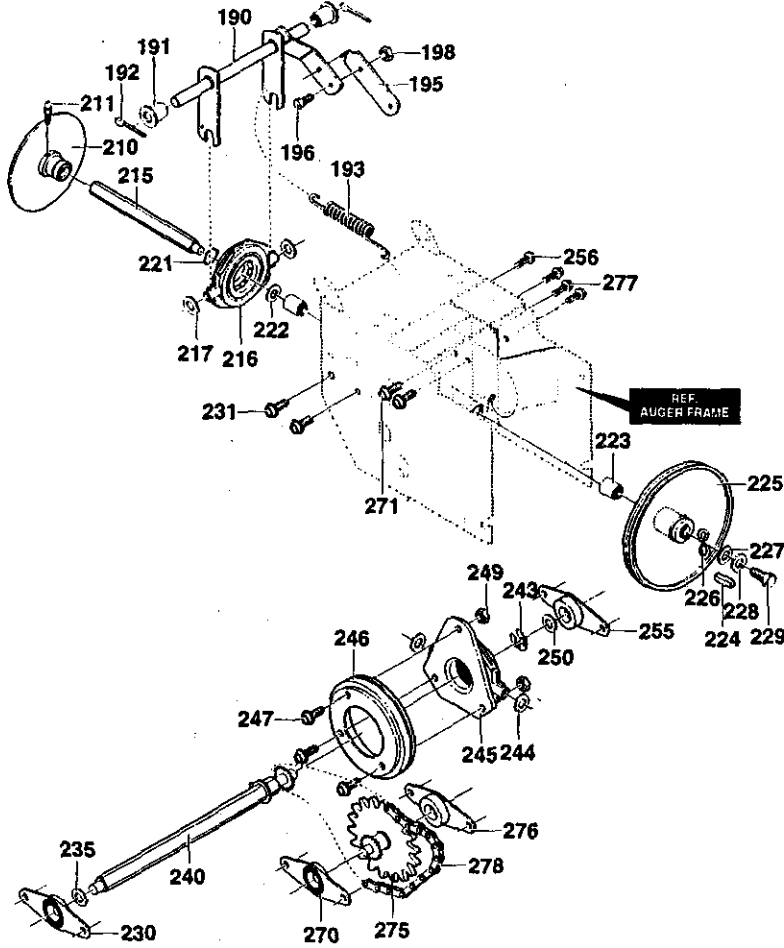

313995K

REF. NO.	PART NO.	PART NAME	REF. NO.	PART NO.	PART NAME
190	579941	Lever, Shaft Tract. Clutch	231	780055	Screw, 5/16-18x.50 Tap.
191	313853	Bearing, Flanged	235	579858	Washer, Sp. .502x.75x.0605
192	137185	Cotter Pin .125x1.00	240	579897	Hex, Assy #40-8
193	313919	Return Spring	243	462	Ring, Retex
195	579937	Lever, Spring Trac Cl.	244	71074	Flatwasher .53x1.00x.063
196	11871	Screw, 1/4-20x.63	245	337029	Bearing, Trunion Cl. Release
198	782585	Nut, 1/4-20 Reghexctrlk	246	313883	Wheel Assy. Friction Disc
210	583163-853	Disc, Assy Fric. Wheel	247	11871	Screw, 1/4-20x.63
211	583206	Zer, Grease	249	303008	Nut, 1/4-20 HexKeps
215	583155	Shaft, Hex Traction	250	579858	Washer, Sp. .502x.75x.0605
216	85501	Bearing, Trunion	255	334163	Bearing & Retainer Assy.
217	71074	Bearing, Trunion	256	780055	Screw, 5/16-18x.50 Tap.
221	73811	Ring, Retaining	270	334163	Bearing & Retainer Assy.
222	580969	Flatwasher .680x1.12x.060	271	780055	Screw, 5/16-18x.50 Tap.
223	43846	Bearing, Ball	275	579893	Jack Assy #41-36T&8T
224	580970	Key, Square	276	334163	Bearing & Retainer Assy.
225	580961	Pulley, V3L	277	780055	Screw, 5/16-18x.50 Tap.
226	580965	Wave Washer	278	579867	Chain, Roller #42
227	578962	Flatwasher .281x1.00x.063			
228	120380	Washer, Regspitk			
229	180020	Screw, 1/4-20x.75			
230	334163	Bearing & Retainer Assy.			

CRAFTSMAN 26" - 8.5H.P. SNOW THROWER 536.886190
GEAR CASE ASSEMBLY

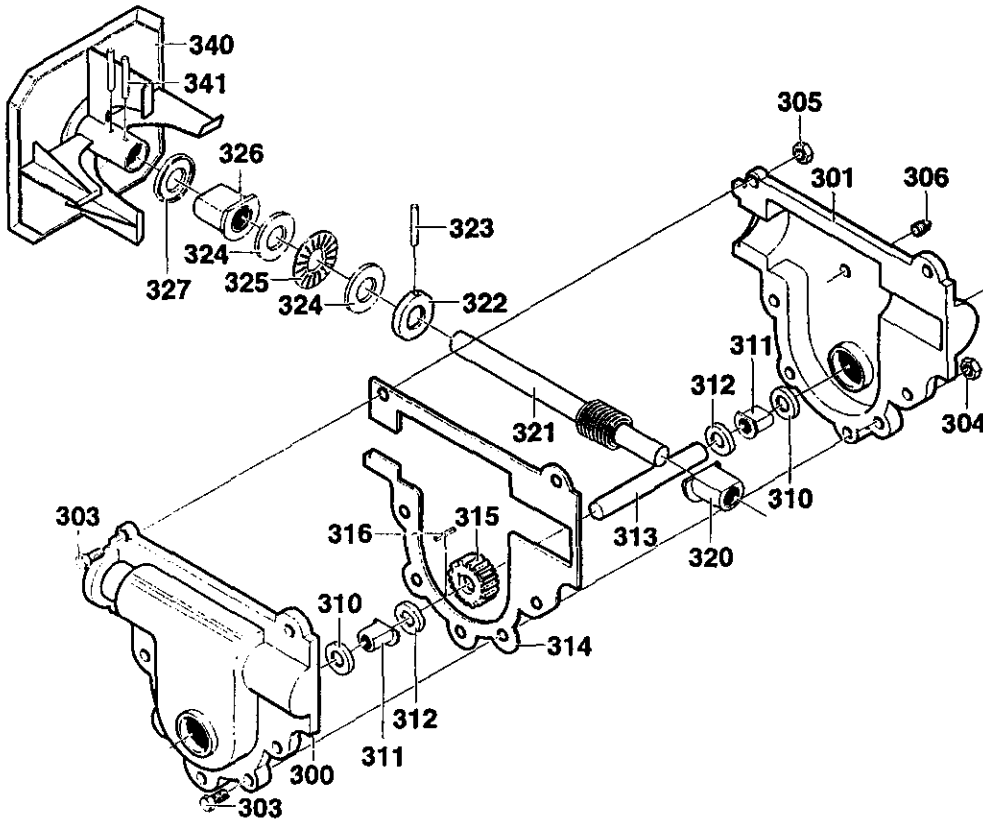

313996B

REF. NO.	PART NO.	PART NAME
300	10577	Gear Case, RH
301	10576	Gear Case, LH
303	710025	Screw, 1/4-20x.75
304	46931	Nut, 1/4-20 Mac-Lock
305	303008	Nut, 1/4-20 Hexkeys
306	9344	Screw, 3/8-16x.50 Tap.
310	9566	Oil Seal
311	50304	Bearing, Flanged
312	48275	Flatwasher .752x1.24x.093
313	340287	Shaft, Auger Output
314	51279	Gasket, Gear Case
315	51405	Gear, Worm

REF. NO.	PART NO.	PART NAME
316	431787	Key, Woodruff #61
320	50221	Bearing, Flanged
321	583125	Shaft, Worm Imp
322	580295	Thrust Collar
323	454565	Spring Pin
324	48275	Flatwasher .752x1.24x.093
325	313828	Bearing, Roll
326	50304	Bearing, Flanged
327	9566	Oil Seal
340	760194-853	Impel Assy.
341	454565	Spring Pin

**CRAFTSMAN 26" - 8.5H.P. SNOW THROWER 536.886190
AUGER HOUSING ASSEMBLY**

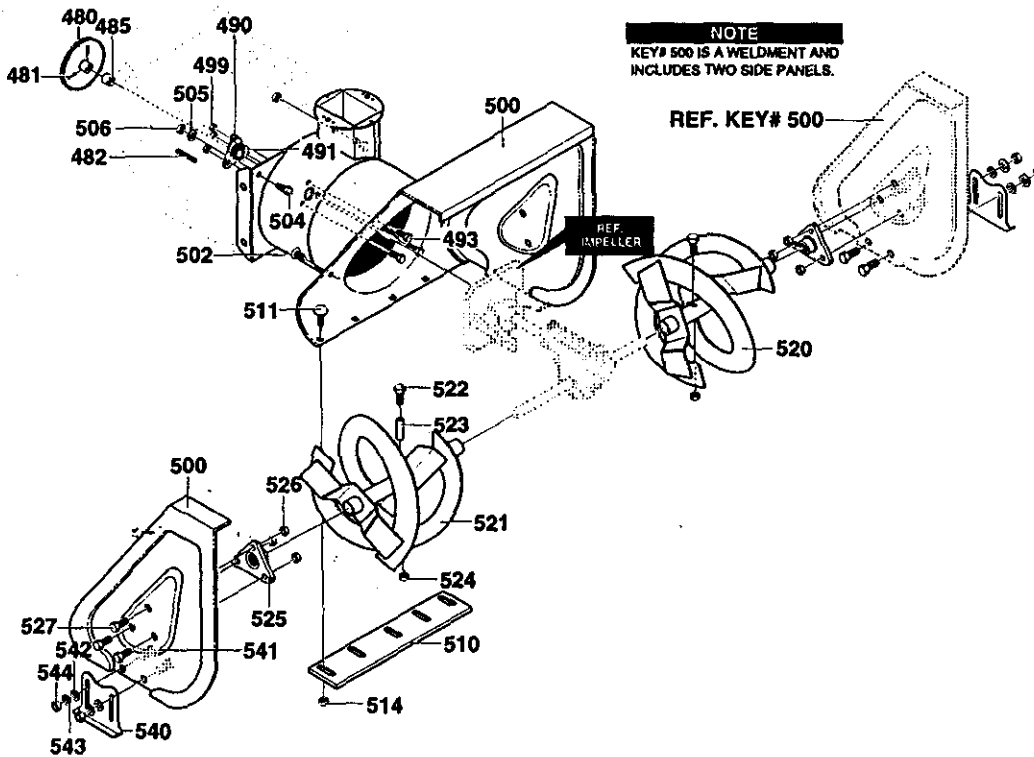

339972F

REF. NO.	PART NO.	PART NAME
480	583124	Pulley, V4L
481	577400	Screw 5/16-18x.63
482	71371	Square Key .18Sqx.88Lg
485	334514	Spacer, Slev .676x1x.53
490	582960	Retainer, Ball
491	43846	Bearing, Ball
493	180077	Screw, 5/16-18x.75
499	710026	Nut, 5/16-18 Hexwdfilk
500	760809-833	Housing Assy.
502	309235	Ratchet Fastener
504	71003	Screw, 3/8-16x.75
505	120382	Washer, Regspstk
506	1499	Nut, 3/8-16 Reghexctrik
510	581399-853	Blade, Scraper 24"
511	340714	Carr. Bolt, 1/4-20x.75
514	780285	Nut, 1/4-20 Whiz-lk
520	339503-853	Auger Assy LH
521	339506-853	Auger Assy RH

REF. NO.	PART NO.	PART NAME
522	*	Screw, 1/4-20x1.75
523	3943	Spacer Sleeve
524	*	Nut, 1/4-20 Reghexctrik
525	9517	Flanged Bearing
526	8619	Nut, 5/16-18 Wdfil
527	9357	Screw, 5/16-18x.75
540	780061	Skid, Height Adjust
541	340720	Carr. Bolt 5/16-18x.75
542	120393	Flatwasher .344x.69x.065
543	120638	Washer, Hvsptlk
544	120376	Nut, 5/16-18 Reghex

* When ordering replacement parts order Shear Pin, part #760875

CRAFTSMAN 26" - 8.5H.P. SNOW THROWER 536.886190

DISCHARGE CHUTE ASSEMBLY

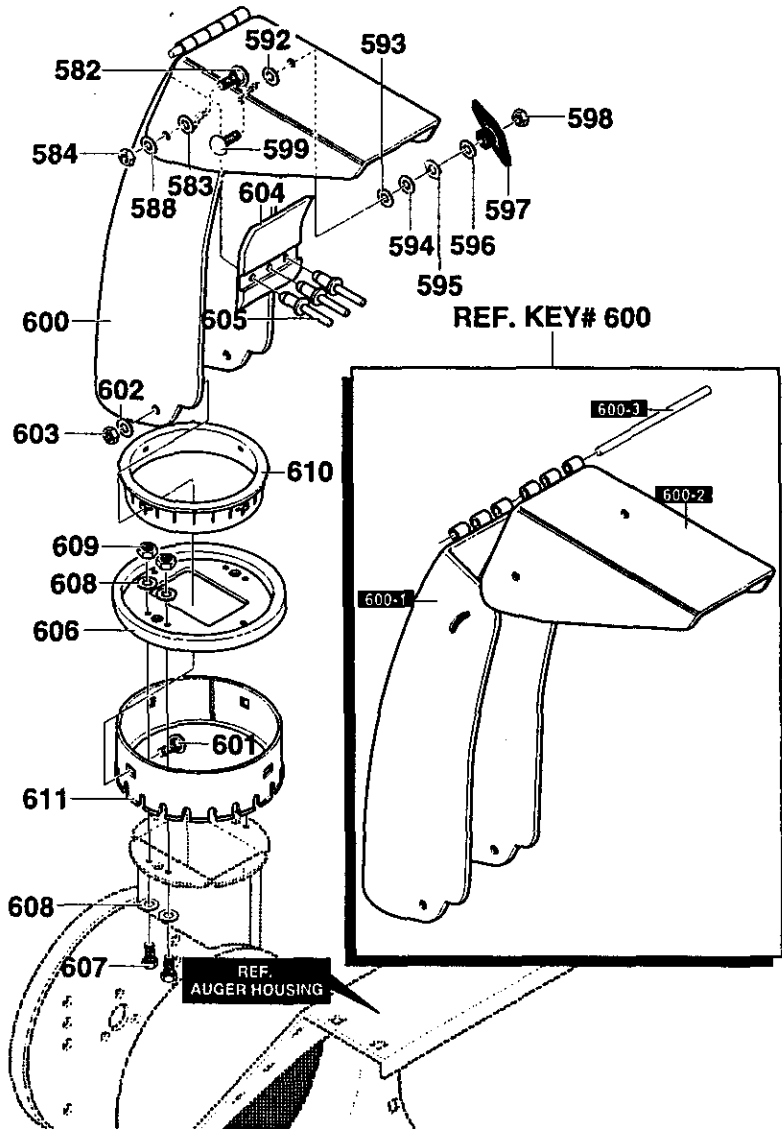

337160E

REF. NO.	PART NO.	PART NAME
582	340720	Carr. Bolt 5/16-18x.75
583	12021	Washer, Plastic
584	71038	Nut, 5/16-18 hexnylon
588	6711	Plastic Washer
592	12021	Plastic Washer
593	6711	Plastic Washer
594	120393	Flatwasher .344x.69x.065
595	120638	Washer, Hvsptlk
596	120393	Flatwasher .344x.69x.065
597	13527	Knob, T 2 Blade
598	120376	Nut, 5/16-18 Reghex
599	126358	Carr. Bolt 5/16-18x1.00
600	760990-853	Chute Assembly
600-1	760989	Lower Chute

REF. NO.	PART NO.	PART NAME
600-2	11780	Upper Chute
600-3	305216	Hinge Pin
601	586280	Carr. Bolt 5/16-18x1.00
602	120393	Flatwasher .344x.69x.065
603	71038	Nut, 5/16-18 Hexnyl
604	760268	Flap, chute Insert
605	760987	Pop, Rivet
606	585214-853	Collar, Chute Rect.
607	180020	Screw, 1/4-20x.75
608	120392	Flatwasher .281x.63x.065
609	782585	Nut, 1/4-20 Reghexctrik
610	337227	Retainer, Ring Inner
611	585193	Retainer, Ring Outer

CRAFTSMAN 26" - 8.5H.P. SNOW THROWER 536.886190

HANDLE ASSEMBLY

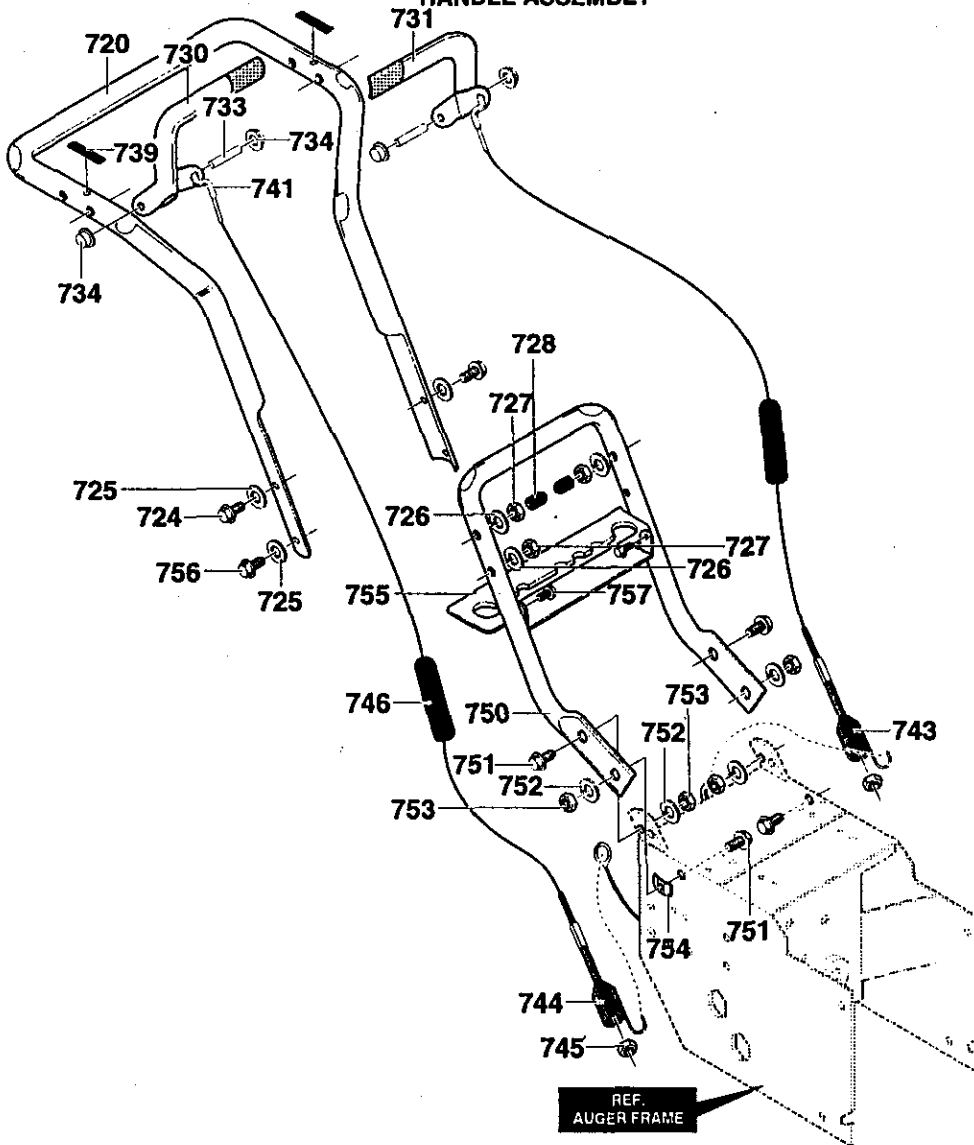

339622B

REF NO.	PART NO.	PART NAME
720	9552-853	Upper Handle
724	11234	Screw, 5/16-18x2.75
725	120393	Flatwasher .344x.69x.065
726	120638	Washer, Hvsptlk
727	120376	Nut, 5/16-18 Reghex
728	11261	Stop, Red Plastic
730	334195	Kit for RH Handle Assy
731	334195	Kit for LH Handle Assy.
733	4140	Pin, Clutch Handle
734	3535	Nut, Push On
739	4049	Bumper, Rect.
741	1579	Cable, Clutch
743	579869	Spring, Tension

REF NO.	PART NO.	PART NAME
744	1673	Spring, Auger Clutch
745	782585	Nut, 1/4-20 Reghexctrik
746	308146	Boot, Clutch Spring
750	339541-853	Handle, Lower
751	180079	Screw 5/16-18x1.00
752	120638	Washer, Hvsptlk
753	120376	Nut, 5/16-18 Reghex
754	309436	Pushnut, 5/16
755	337407-853	Brkt, Gear Selector
756	180087	Screw, 5/16-18x2.00
757	300303	Screw, Plastite

CRAFTSMAN 26" - 8.5H.P. SNOW THROWER 536.886190
WHEEL ASSEMBLY 679

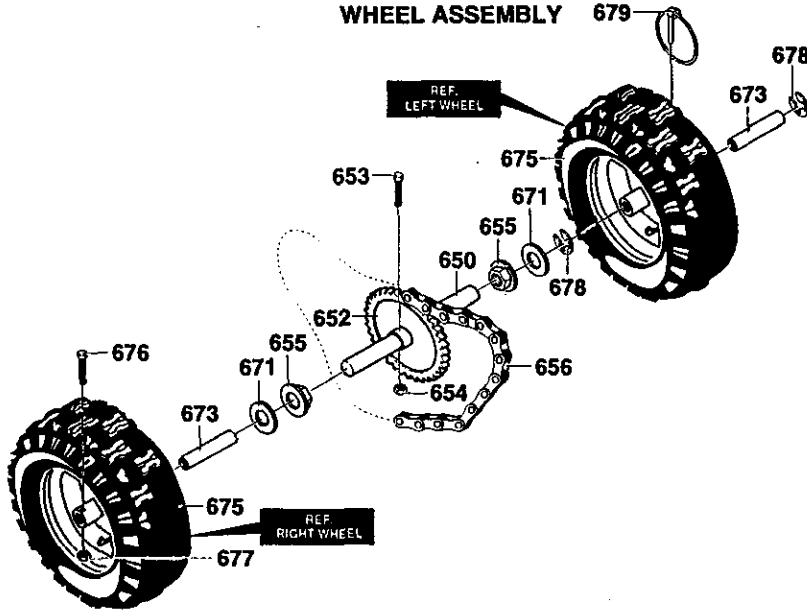

318542F

REF. NO.	PART NO.	PART NAME
650	580883	Shaft, Axle Wheel/mid
652	583012	Sprkt & Hub Assy.
653	73839	Screw 14-20x2.25
654	782585	Nut, 1/4-20 Reghxctrk
655	581730	Bearing, Flanged
656	579867	Chain, Roller #42x40P
671	73840	Flatwasher .765x1.12x.06

REF. NO.	PART NO.	PART NAME
673	585591	Bushing, Wheel 4"Lg
675	318504	Tire & Rim
676	577015	Screw Shr 1/4-20x1.75
677	782585	Nut, 1/4-20 Reghxctrk
678	239	Ring, Ret.
679	73842	Pin, Klik

SHIFT YOKE ASSEMBLY

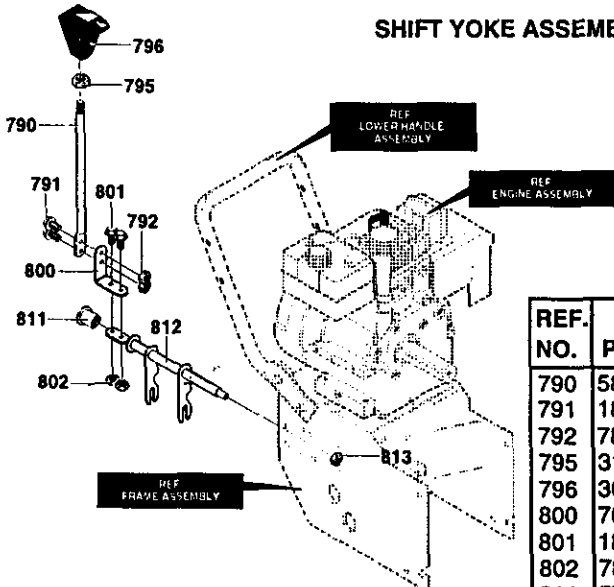

REF. NO.	PART NO.	PART NAME
790	581631-853	Shift Rod
791	180020	Screw, 1/4-20x.75
792	782585	Nut, 1/4-20 Reghexctrk
795	318486	Nut, 1/2-13 Hexjam
796	304438	Knob, Shift
800	760564	Lever, Spring
801	180020	Screw, 1/4-20x.75
802	782585	Nut, 1/4-20 Reghexctrk
811	579944	Bearing, Flanged
812	581795	Rod, Assy Yoke
813	1499	Nut, 3/8-16 Reghexctrk

319053D

CRAFTSMAN 26" - 8.5H.P. SNOW THROWER 536.886190
CHUTE CONTROL ROD ASSEMBLY

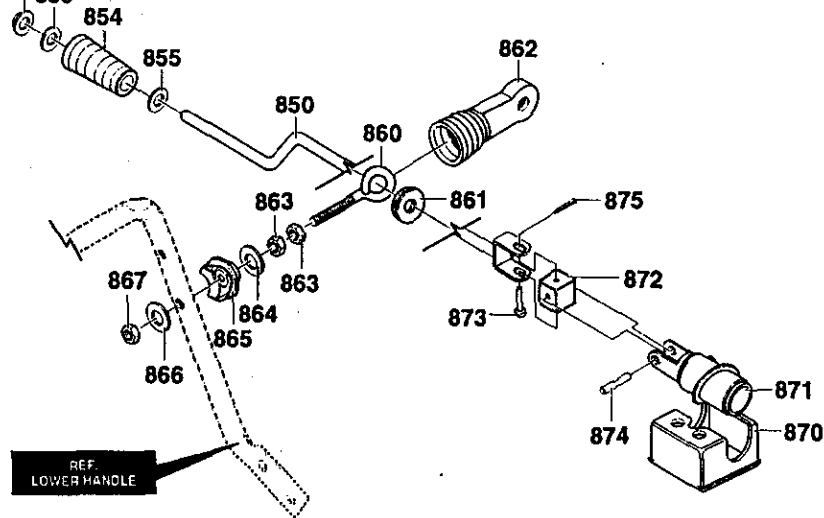

334215C

REF. NO.	PART NO.	PART NAME
850	585426	Crank Assy, W/yoke
854	307399	Chute Crank Handle
855	309312	Flatwasher, .39x.70x.35
856	578159	Ring, Ret. E.
860	581618	Eye Bolt 3/8-16x6.00
861	148	Grommet Eye Bolt
862	308145	Boot, Eye Bolt Chute Crank
863	124829	Nut, 3/8-16 Hexjam
864	120394	Flatwasher .406x.81x.065

REF. NO.	PART NO.	PART NAME
865	309344	Adapter, Boot to Handle
866	120394	Flatwasher .406x.81x.065
867	71046	Nut, 3/8-16 Hexnyl
870	585195	Bracket, Worm Mtg
871	585196	Worm, Gear Chute Rot
872	578063	Block Univ. Pivot
873	578309	Clevis Pin
874	578060	Pin, Univ. Joint
875	579493	Cotter Pin .06x.50

DECALS

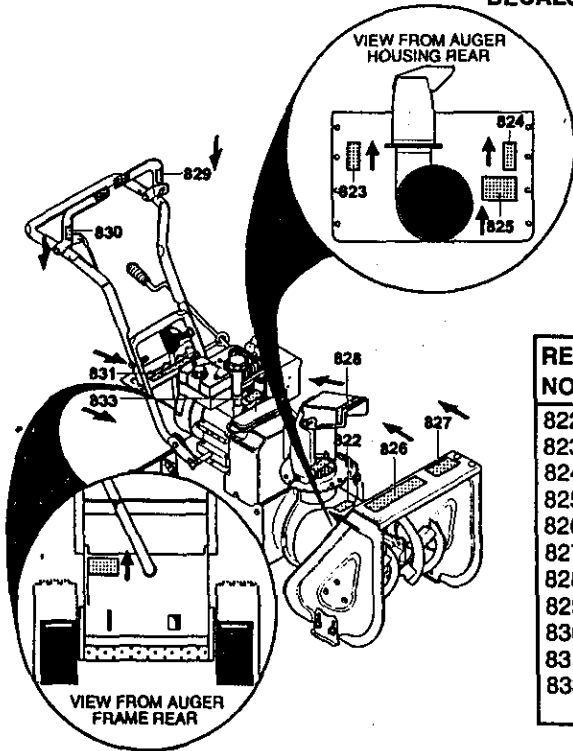

314005F

REF. NO.	PART NO.	PART NAME
822	760971	Decal, 9" Impeller
823	313892	Decal, Danger Chute
824	70141	Decal, Danger Auger
825	302922	Decal, Danger English
826	760972	Decal, Craftsman
827	761094	Decal, El Start 8/26E
828	761079	Decal, Danger Chute
829	3902	Decal, Traction Dr. Engage
830	3903	Decal, Gear Selector
831	340047	Decal, Gear Selector
833	760983	Decal, Toolbox

CRAFTSMAN 4-CYCLE ENGINE MODEL NUMBER: 143.988003
 Carburetor No. 640052

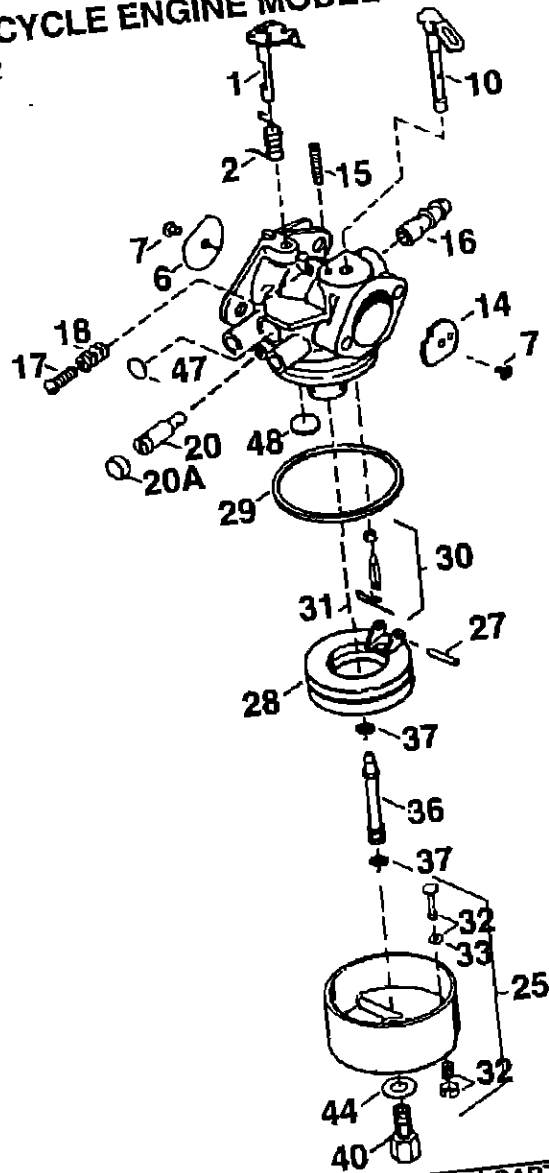

REF. NO.	PART NO.	PART NAME	REF. NO.	PART NO.	PART NAME
0	640052	Carburetor (incl 184 on engine)	28	632019	Float
1	631776A	Throttle Shaft & Lever Ass'y.	29	631028	Float Bowl "O" Ring
2	631970	Throttle Return Spring	30	631021	Inlet Needle, Seat & Clip (Incl 31)
6	631778	Throtter Shutter	31	631022	Spring Clip
7	650506	Shutter Screw	32	27136A	Bowl Drain Assembly
10	632112	Choke Shaft & Lever Assy	33	27554	Bowl Drain Gasket
14	632174	Choke Shutter	36	640005	Main Nozzle Tube
15	630735	Choke Positioning Spring	37	632547	"O" Ring, Main nozzle Tube
16	632164	Fuel Fitting	40	640055	High Speed Bowl Nut
17	650417	Throttle Crack Screw/Idle Speed Screw	44	27110	Bowl Nut Washer
18	630766	Tension Spring	47	630748	Welch Plug, Idle Mixture Well
20	640016	Idle Restrictor Screw	48	631027	Welch Plug, Atmospheric Vent
20A	640053	Idler Restrictor Screw Cap			
25	631951	Float Bowl Assy (incl 32&33)			
27	631024	Float Shaft			

CRAFTSMAN 4-CYCLE ENGINE MODEL NUMBER: 143.988003

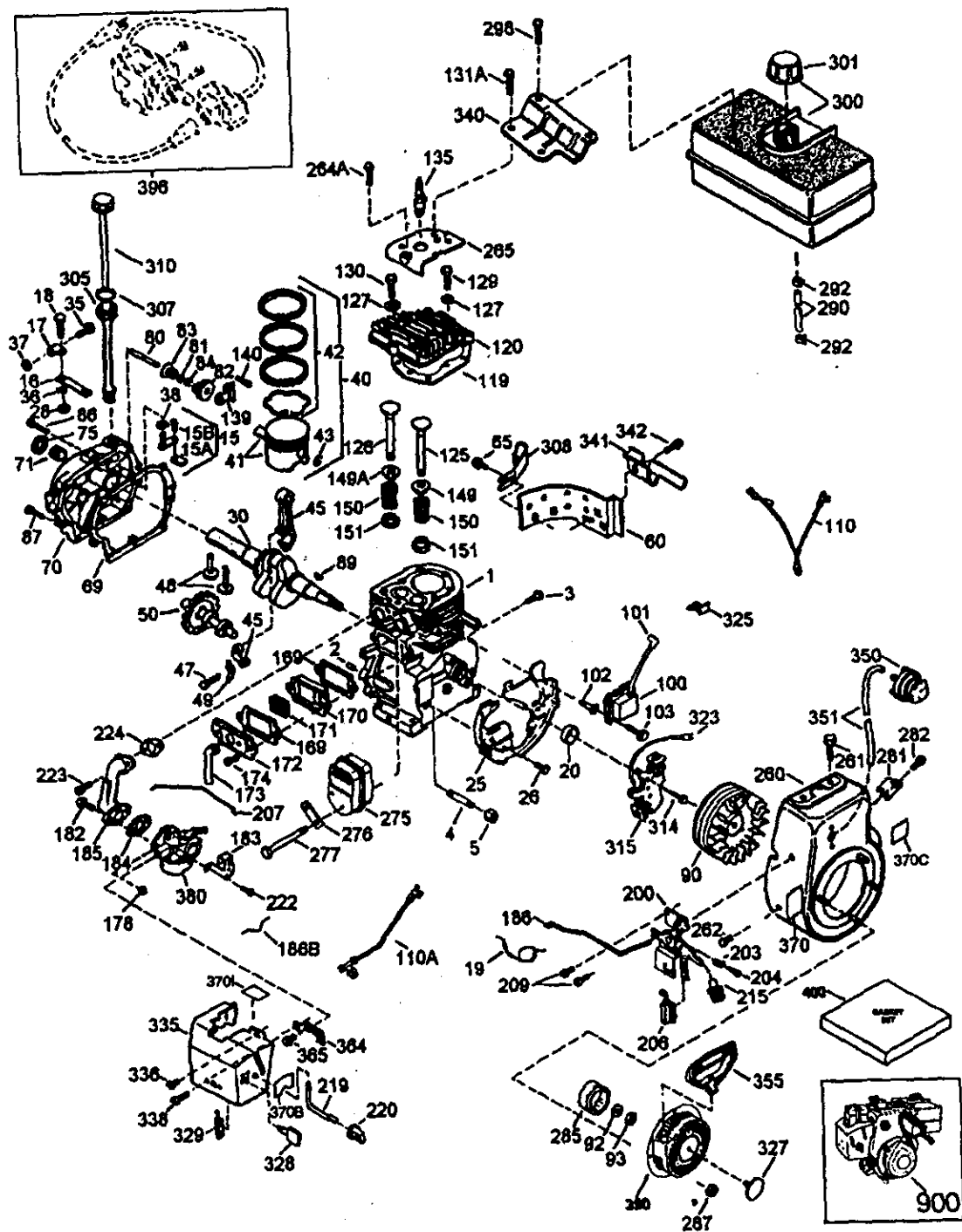

CRAFTSMAN 4-CYCLE ENGINE MODEL NUMBER: 143.988003

Ref.#	Part No.	Description
1	35385	Cylinder (Incl 2,20,72)
2	27652	Dowel Pin
3	650820	Screw, 1/4-20x1/2"
4	31857	Oil Drain Extension
5	30969	Extension Cap
15	30699C	Governor Rod (Incl 15A & 15B)
15A	30700	Governor Yoke
15B	650494	Screw 6-40 x 5/16"
16	33454	Governor Lever
17	29916	Governor Lever Clamp
18	651028	Screw 8-32x3/8"
19	34663	Speed Control Spring
20	35319	Oil Seal
25	36460	Blower Housing Baffle
26	650561	Screw 1/4-20x5/8"
28	30322	Locknut 8-32
30	36245	Crankshaft
35	29826	Screw 10-32x3/4"
36	29918	Lockwasher
37	29216	Locknut 10-32
38	29642	Retaining Ring
40	40011	Piston,Pin,&Ring Set(Std)
40	40012	Piston,Pin,&Ring Set(.010")
41	40009	Piston&Pin Assy(Std(Incl.43)
41	40010	Piston&Pin Assy(.010" OS)(Incl 43)
42	40013	Ring Set (Std)
42	40014	Ring Set (.010" OS)
43	27888	Piston Pin Retaining Ring
45	36897	Connecting Rod Assy(incl 47,49)
47	651033	Connecting Rod Bolt
48	34034	Valve Lifter
49	36896	Oil Dipper
50	35375	Camshaft (MCR)
60	33273A	Blower Hsing Extension
65	650128	Screw 10-24x1/2"
69	35262A	Cylinder Cover Gasket
70	35376	Cylinder Cover (Incl 71,75,&80)
71	35377	Crankshaft Bushing
75	35319	Oil Seal
80	31845	Governor Shaft
81	30590A	Washer
82	35378	Governor Gear Assy.(Incl 81)
83	30588A	Governor Spool
84	29193	Retaining Ring
86	650833	Screw, 1/4-20x1-3/16"
87	650832	Screw 1/4-20x1-11/16"
89	32589	Flywheel Key
90	611093	Flywheel (w/ring gear)
92	650880	Lock Washer
93	650881	Flywheel Nut
100	35135	Solid State Ignition
101	610118	Spark Plug Cover
102	651024	Solid State Mtng Stud
103	651007	Screw Torx T-15 10-24x15/16
110	35187	Ground Wire
110A	37047	Ground Wire
119	36448	Cylinder Head Gasket
120	36449	Cylinder Head
125	27878A	Exhaust Valve (std)(Incl 151)
125	27880A	Exhaust Valve(1/32" OS)(Incl 151)
126	34035	Intake Valve (std)(Incl. 151)
126	34036	Intake Valve (1/32" OS)(Incl 151)
127	650691	Washer
129	650727	Screw, 5/16-18x1-3/4"
130	6021A	Screw 5/16-18x1-1/2"
131A	650713	Screw 5/16-18 x 5/8"
135	35395	Resistor Spark Plug(RJ19LM)
139	33369	Governor Gear Bracket
140	650836	Screw 10-24x1/2"
149	27882	Valve Spring Cap

Ref.#	Part No.	Description
149A	35862	Valve Spring Cap
150	27881	Valve Spring
151	32581	Valve Spring Keeper
169	27896A	Valve Cover Gasket
170	28423	Breather Body
171	28424	Breather Element
172	28425	Valve Cover
173	35350	Breather Tube
174	650128	Screw 10-24 x 1/2"
178	29752	Nut & Lock Washer 1/4-28"
182	30088A	Screw, 1/4-28x1"
183	34587A	Choke Bracket
184	33263	Carburetor To Intake Pine Gskt
185	33877	Intake Pipe
186	34667	Governor Link
186B	36652	Choke Spring
200	34677	Control Bkt (Incl. 19, 203, 204 &206)
203	31342	Compression Spring
204	651029	Screw, T10 5-40x7/16"
206	610973	Terminal
207	33878	Throttle Link
209	650821	Screw 10-32 x 1/2"
215	35440	Control Knob
219	34586	Choke Rod
220	35438	Choke Knob
222	28820	Screw 10-32 x 1/2"
223	650378	Screw Torx T-40 5/16-18x1-1/8"
224	27915A	Intake Pipe Gasket
260	35447A	Blower Housing
261	650788	Screw 5/16-18x3/4"
262	29747B	Screw Torx T-40 5/16-24x21/32"
264A	650802	Screw, 1/4-20x5/8"
265	33272B	Cylinder Head Cover(Black)
275	35056	Muffler
276	31588	Locking Plate
277	651002	Screw 5/16-18x4-3/16"
281	33013	Starter Bubble Cover
282	650760	Screw 8-32x3/8"
285	35985B	Starter Cup
287	29752	Nut & Lock washer 1/4-28
290	30705	Fuel Line
292	26460	Fuel Line Clamp
298	650665	Screw 1/4-15 x 3/4"
300	34156A	Fuel Tank (Incl 292 & 301)
301	35355	Fuel Cap
305	35554	Oil Fill Tube
307	35499	"O" Ring
308	35540	Fill Tube Clip
310	36205	Dipstick
314	650873	Screw 1/4-20 x 3/4"
315	611111	Alternator Coil(18 Watt)(Incl 323)
323	611118	Terminal
325	29443	Wire Clip
327	35392	Starter Plug
328	35593	Ignition Key
329	610973	Terminal
335	35057A	Carburetor Cover
336	650765	Screw 10-32x1/2"
338	28942	Screw 10-32x3/8"
340	34154	Fuel Tank Bracket
341	34155	Fuel Tank Bracket
342	650561	Screw 1/4-20x5/8"
350	570682	Primer Bulb
351	32180C	Primer Line
355	590574	Starter Handle(Mitten Grip)
364	33377	Carburetor Cover Bracket
365	650767	Screw 8-32x27/64"
370	36261	Identification Decal
370B	35878	Warning Decal
370C	36501	Primer Decal
370I	35077	Instruction Decal
380	640052	Carburetor (Incl. 184)
390	590733	Rewind Starter
396	33329D	Electric Starter Motor Kit (Optional)
400	36450A	Gasket Set

CRAFTSMAN 4-CYCLE ENGINE MODEL NUMBER: 143.988003

Starter No. 590749

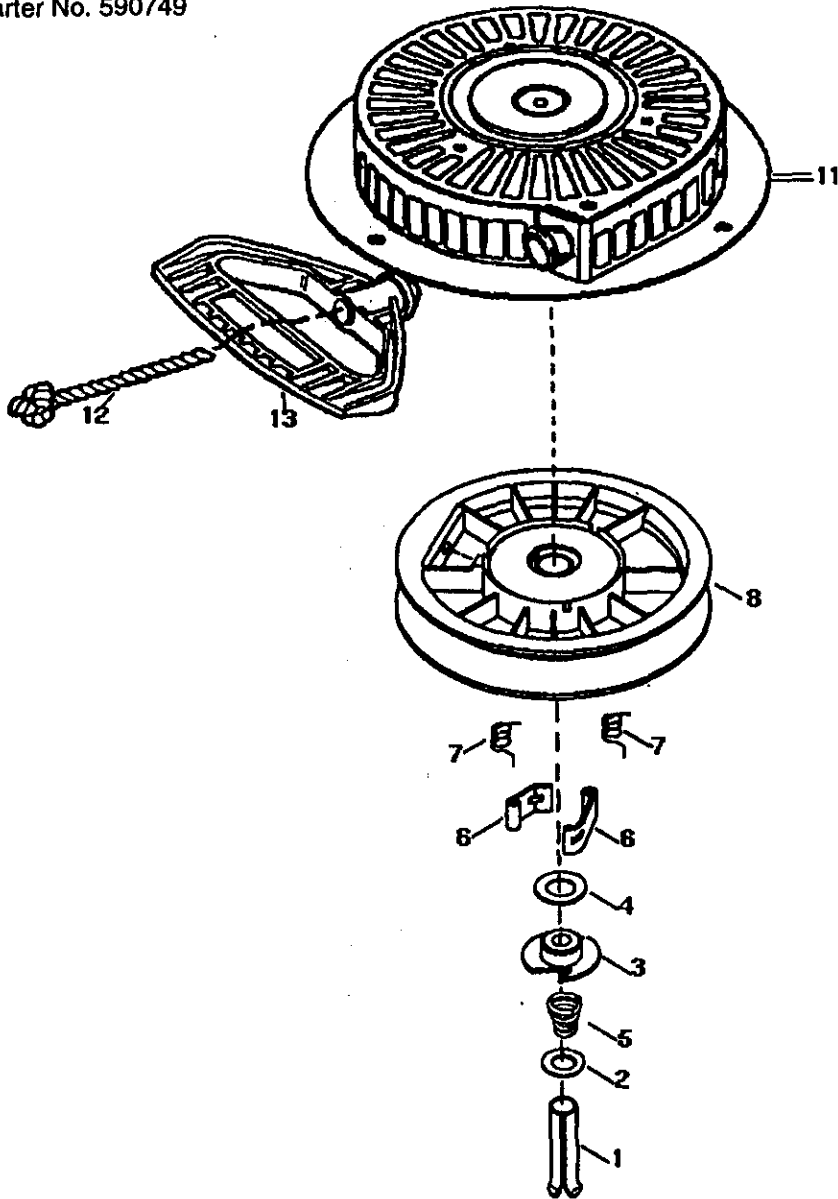

REF. NO.	PART NO.	PART NAME
0	590749	Rewind Starter
1	590599A	Spring Pin (Incl. 4)
2	590600	Washer
3	590679	Retainer
4	590601	Washer
5	590678	Brake Spring
6	590680	Starter Dog
7	590412	Dog Spring
8	590682	Pulley & Rewind Sprg Assy
11	590750	Starter Housing Assy
12	590535	Starter Rope (Length 98"x9/64" dia)
13	590574	Mitten Grip Handle(not included with starter)

For the repair or replacement parts you need delivered directly to your home

Call 7 am-7 pm, 7 days a week

1-800-366-PART

(1-800-366-7278)

Para ordenar piezas con entrega a domicilio -1-800-659-7084

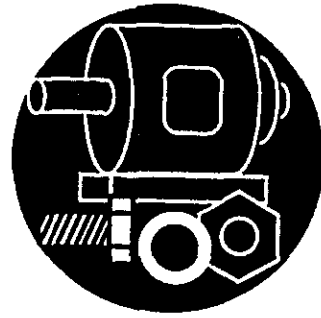

For in-house major brand repair service

Call 24 hours a day, 7 days a week

1-800-4-REPAIR

(1-800-473-7247)

Para pedir servicio de reparación a domicilio - 1-800-676-5811



For the location of a Sears Parts and Repair Center in your area

Call 24 hours a day, 7 days a week

1-800-488-1222



For information on purchasing a Sears Maintenance Agreement or to inquire about an existing Agreement

Call 9 am -5pm, Monday-Saturday

1-800-827-6655



When requesting service or ordering parts, always provide the following information:

- Product Type
- Part Number
- Model Number
- Part Description

SEARS
REPAIR SERVICES

America's Repair Specialists

Printed in U.S.A.