



**RECORD YOUR MODEL NUMBER
(Now, while you can see it)**

The model and serial number of your new TV are located on the back of the TV cabinet. For your future convenience, we suggest that you record these numbers here:

MODEL NO. _____

SERIAL NO. _____



WARNING
RISK OF ELECTRIC SHOCK
DO NOT OPEN



WARNING:

TO REDUCE THE RISK OF ELECTRIC SHOCK DO NOT REMOVE COVER (OR BACK). NO USER SERVICEABLE PARTS INSIDE. REFER SERVICING TO QUALIFIED SERVICE PERSONNEL.



The lightning flash with arrowhead symbol, within an equilateral triangle, is intended to alert the user to the presence of uninsulated "dangerous voltage" within the product's enclosure that may be of sufficient magnitude to constitute a risk of electric shock to persons.



The exclamation point within an equilateral triangle is intended to alert the user to the presence of important operating and maintenance (servicing) instructions in the literature accompanying the appliance.

WARNING:

TO PREVENT FIRE OR SHOCK HAZARDS, DO NOT EXPOSE THIS PRODUCT TO RAIN OR MOISTURE.

POWER CORD POLARIZATION:

CAUTION: TO PREVENT ELECTRIC SHOCK, MATCH WIDE BLADE OF PLUG TO WIDE SLOT, FULLY INSERT.

ATTENTION: POUR ÉVITER LES CHOCS ÉLECTRIQUES, INTRODUIRE LA LAME LA PLUS LARGE DE LA FICHE DANS LA BORNE CORRESPONDANTE DE LA PRISE ET POUSSER JUSQU'AU FOND.

NOTE TO CABLE/TV INSTALLER:

This reminder is provided to call the cable TV system installer's attention to Article 820-40 of the National Electric Code (U.S.A.). The code provides guidelines for proper grounding and, in particular, specifies that the cable ground shall be connected to the grounding system of the building, as close to the point of the cable entry as practical.

REGULATORY INFORMATION:

This equipment has been tested and found to comply with the limits for a Class B digital device, pursuant to Part 15 of the FCC Rules. These limits are designed to provide reasonable protection against harmful interference when the equipment is operated in a residential installation. This equipment generates, uses and can radiate radio frequency energy and, if not installed and used in accordance with the instruction manual, may cause harmful interference to radio communications. However, there is no guarantee that interference will not occur in a particular installation. If this equipment does cause harmful interference to radio or television reception, which can be determined by turning the equipment off and on, the user is encouraged to try to correct the interference by one or more of the following measures:

- Reorient or relocate the receiving antenna.
- Increase the separation between the equipment and receiver.
- Connect the equipment into an outlet on a circuit different from that to which the receiver is connected.
- Consult the dealer or an experienced radio/TV technician for help.

CAUTION:

Do not attempt to modify this product in any way without written authorization from Zenith Electronics Corporation. Unauthorized modification could void the user's authority to operate this product.

"Entertainment Machine" is a trademark of Zenith Electronics Corporation

IMPORTANT SAFETY INSTRUCTIONS

Important safeguards for you and your new product

Your product has been manufactured and tested with your safety in mind. However, improper use can result in potential electrical shock or fire hazards. To avoid defeating the safeguards that have been built into your new product, please read and observe the following safety points when installing and using your new product, and save them for future reference.

Observing the simple precautions discussed in this booklet can help you get many years of enjoyment and safe operation that are built into your new product.

This product complies with all applicable U.S. Federal safety requirements, and those of the Canadian Standards Association.

1. Read Instructions

All the safety and operating instructions should be read before the product is operated.

2. Follow Instructions

All operating and use instructions should be followed.

3. Retain Instructions

The safety and operating instructions should be retained for future reference.

4. Heed Warnings

All warnings on the product and in the operating instructions should be adhered to.

5. Cleaning

Unplug this product from the wall outlet before cleaning. Do not use liquid cleaners or aerosol cleaners. Use a damp cloth for cleaning.

6. Water and Moisture

Do not use this product near water - for example, near a bath tub, wash bowl, kitchen sink, or laundry tub, in a wet basement, or near a swimming pool.

7. Accessories

Do not place this product on an unstable cart, stand, tripod, bracket, or table. The product may fall, causing serious injury to a child or adult, and serious damage to the product. Use only with a cart, stand, tripod, bracket, or table recommended by the manufacturer, or sold with the product. Any mounting of the product should follow the manufacturer's instructions, and should use a mounting accessory recommended by the manufacturer.

8. Transporting Product

A product and cart combination should be moved with care. Quick stops, excessive force, and uneven surfaces may cause the product and cart combination to overturn.



PORTABLE CART WARNING

9. Attachments

Do not use attachments not recommended by the product manufacturer as they may cause hazards.

10. Ventilation

Slots and openings in the cabinet are provided for ventilation and to ensure reliable operation of the product and to protect it from overheating, and these openings must not be blocked or covered. The openings should never be blocked by placing the product on a bed, sofa, rug, or other similar surface. This product should not be placed in a built-in installation such as a bookcase or rack unless proper ventilation is provided or the manufacturer's instructions have been adhered to.

11. Power Sources

This product should be operated only from the type of power source indicated on the marking label. If you are not sure of the type of power supply to your home, consult your product dealer or local power company. For products intended to operate from battery power, or other sources, refer to the operating instructions.

12. Line-Cord Polarization

This product is equipped with a polarized alternating-current line plug (a plug having one blade wider than the other). This plug will fit into the power outlet only one way. This is a safety feature. If you are unable to insert the plug fully into the outlet, try reversing the plug. If the plug should still fail to fit, contact your electrician to replace your obsolete outlet. Do not defeat the safety purpose of the polarized plug.

13. Power-Cord Protection

Power-supply cords should be routed so that they are not likely to be walked on or pinched by items placed upon or against them, paying particular attention to cords at plugs, convenience receptacles, and the point where they exit from the product.

(Continued on next page)

IMPORTANT SAFETY INSTRUCTIONS

(Continued from previous page)

14. Outdoor Antenna Grounding

If an outside antenna or cable system is connected to the product, be sure the antenna or cable system is grounded so as to provide some protection against voltage surges and built-up static charges. Article 810 of the National Electrical Code (U.S.A.), ANSI/ NFPA 70 provides information with regard to proper grounding of the mast and supporting structure, grounding of the lead-in wire to an antenna discharge unit, size of grounding conductors, location of antenna-discharge unit, connection to grounding electrodes, and requirements for the grounding electrode.

Example of Grounding According to National Electrical Code Instructions

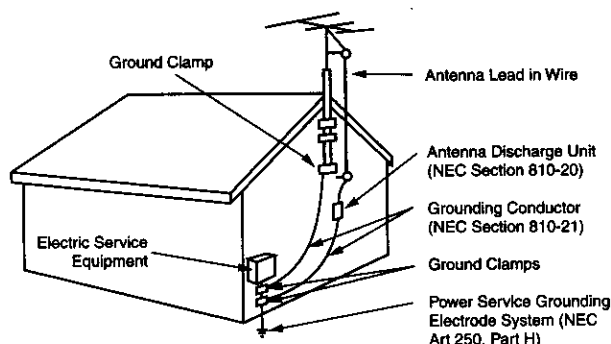

NEC - National Electrical Code

15. Lightning

For added protection for this product (receiver) during a lightning storm, or when it is left unattended and unused for long periods of time, unplug it from the wall outlet and disconnect the antenna or cable system. This will prevent damage to the product due to lightning and power-line surges.

16. Power Lines

An outside antenna system should not be located in the vicinity of overhead power lines or other electric light or power circuits, or where it can fall into such power lines or circuits. When installing an outside antenna system, extreme care should be taken to keep from touching such power lines or circuits as contact with them might be fatal.

17. Overloading

Do not overload wall outlets and extension cords as this can result in a risk of fire or electric shock.

18. Object and Liquid Entry

Never push objects of any kind into this product through openings as they may touch dangerous voltage points or short-out parts that could result in a fire or electric shock. Never spill liquid of any kind on the product.

19. Servicing

Do not attempt to service this product yourself as opening or removing covers may expose you to dangerous voltage or other hazards. Refer all servicing to qualified service personnel.

20. Damage Requiring Service

Unplug this product from the wall outlet and refer servicing to qualified service personnel under the following conditions:

- If the power-supply cord or plug is damaged.
- If liquid has been spilled, or objects have fallen into the product.
- If the product has been exposed to rain or water.
- If the product does not operate normally by following the operating instructions. Adjust only those controls that are covered by the operating instructions as an improper adjustment of other controls may result in damage and will often require extensive work by a qualified technician to restore the product to its normal operation.
- If the product has been dropped or the cabinet has been damaged.
- If the product exhibits a distinct change in performance.

21. Replacement Parts

When replacement parts are required, be sure the service technician has used replacement parts specified by the manufacturer or have the same characteristics as the original part. Unauthorized substitutions may result in fire, electric shock, or other hazards.

22. Safety Check

Upon completion of any service or repairs to this product, ask the service technician to perform safety checks to determine that the product is in proper operating condition.

23. Wall or Ceiling Mounting

The product should be mounted to a wall or ceiling only as recommended by the manufacturer.

24. Heat

The product should be situated away from heat sources such as radiators, heat registers, stoves, or other products (including amplifiers) that produce heat.

Hook-Up Directory

IMPORTANT!!

Use this page to decide where you need to begin your setup. First, find the line below that best describes what you want to do, then go to that page number.

Antenna only

If you are using an antenna and no other equipment, go to page 6

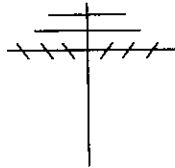

Cable only

If you have cable service or a cable box and no other equipment, go to page 7

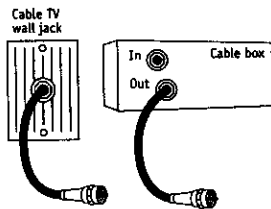

Antenna with VCR

If you are using an antenna and have a VCR, go to page 8

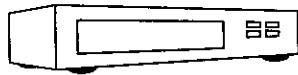
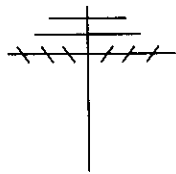

Cable and VCR

If you have cable service or a cable box and a VCR, go to page 9

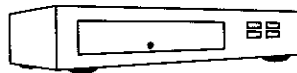
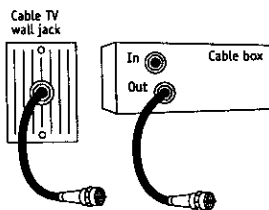

Hook Up Your Antenna to the TV

Connect an antenna to your Entertainment Machine

- 1 Locate the Antenna/Cable jack on the back of your Entertainment Machine.
- 2 Connect the cable that runs from the wall directly to this jack, according to the diagram to the right.
- 3 Remove the back of the remote and put in two AA batteries.

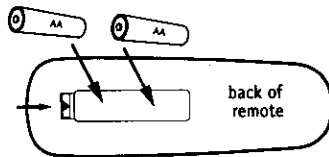

- 4 Plug in your Entertainment Machine. Do not plug it into a switched outlet. Your Entertainment Machine is designed to operate on household current, 120-volt 60 Hertz AC do not attempt to operate it on DC Current.

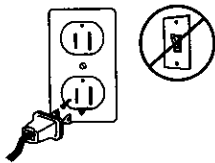

- 5 Go to page 10 to Auto Program your Entertainment Machine.

 If you have a 75 ohm RF cable, then you don't need any adapters!

 Remember, when screwing RF cables onto jacks, clockwise tightens, and counterclockwise loosens.

Flat wire antenna to Entertainment Machine

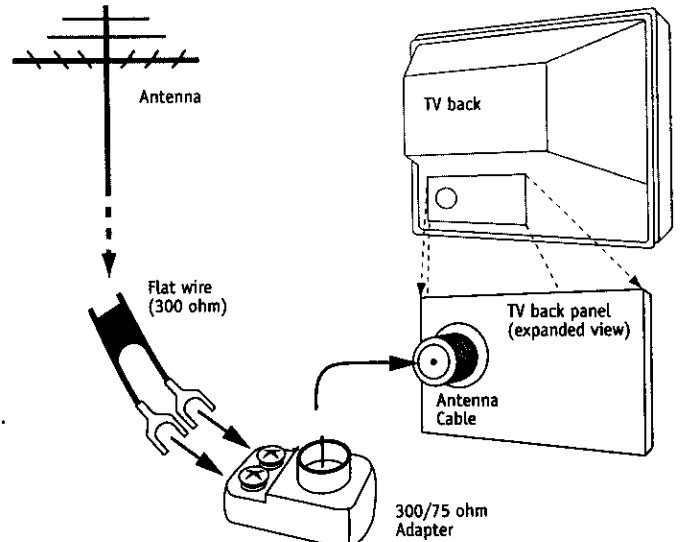

Antenna to Entertainment Machine

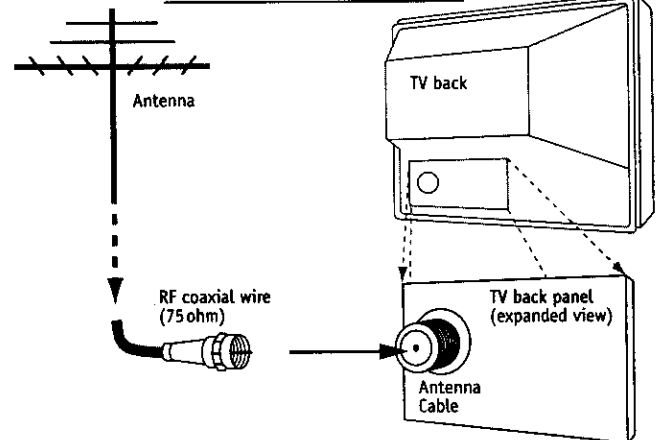

75 OHM RF CABLE

The wire that comes from an off-air antenna or cable service provider. Each end looks like a hex shaped nut with a wire sticking through the middle, and it screws onto the threaded jack on the back of you Entertainment Machine.

300 TO 75 OHM ADAPTER

A small device that connects a two-wire 300 ohm antenna to a 75 ohm RF jack. They are usually about an inch long with two screws on one end and a round opening with a wire sticking out on the other end.

"Entertainment Machine" is a trademark of Zenith Electronics Corporation.

Hook Up Your Cable Service (CATV)

Connect cable service to your Entertainment Machine.

1 Locate the Antenna/Cable jack on the back of your Entertainment Machine.

2 Connect the cable that runs from the wall directly to this jack, according to the diagram to the right.

3 Remove the back of the remote and put in two AA batteries.

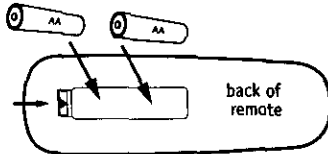

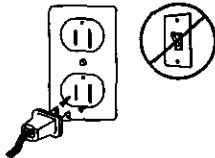

4 Plug in your Entertainment Machine. Do not plug it into a switched outlet. Your Entertainment Machine is designed to operate on household current, 120-volt 60 Hertz AC do not attempt to operate it on DC Current.



5 Go to page 10 to Auto Program your Entertainment Machine.

 If you're using a cable box, leave your TV on channel 3 or 4 and use your cable box to change channels.

 Remember, when screwing RF cables onto jacks, clockwise tightens, and counterclockwise loosens.

 If you're using a cable box, Auto-Program might only find the channel your cable Service is on (usually channel 3 or 4). Don't worry, that's all you need!

Cable to Entertainment Machine

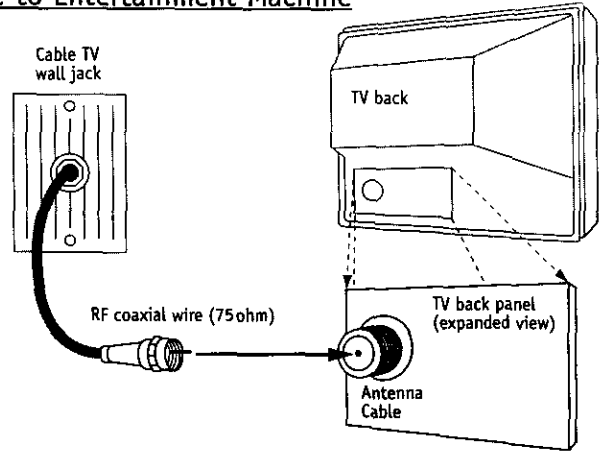

Cable w/Box to Entertainment Machine

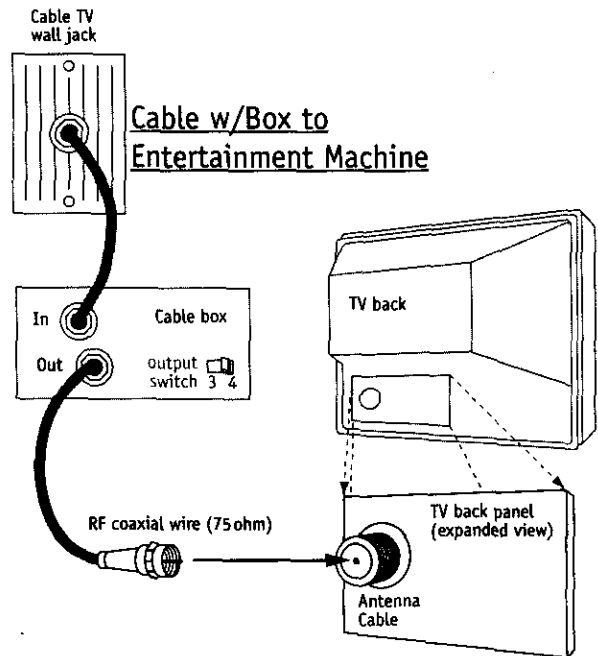

mini glossary

CABLE SERVICE The wire that supplies all your cable TV (CATV) stations.

Hook Up Your Antenna and VCR

Connect an antenna and VCR to your Entertainment Machine.

1 Locate the Antenna/Cable jack on the back of your Entertainment Machine.

2 Connect the cable that runs from the wall directly to this jack, according to the diagram to the right.

3 Remove the back of the remote and put in two AA batteries.

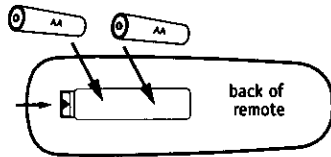

4 Plug in your Entertainment Machine. Do not plug it into a switched outlet. Your Entertainment Machine is designed to operate on household current, 120-volt 60 Hertz AC do not attempt to operate it on DC Current.

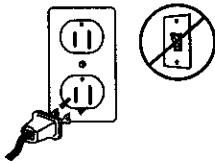

5 Go to page 10 to Auto Program your Entertainment Machine.

 If you have a 75 ohm RF cable, then you don't need any adapters!

 Remember, when screwing RF cables onto jacks, clockwise tightens, and counterclockwise loosens.

Flat wire antenna w/VCR to Entertainment Machine

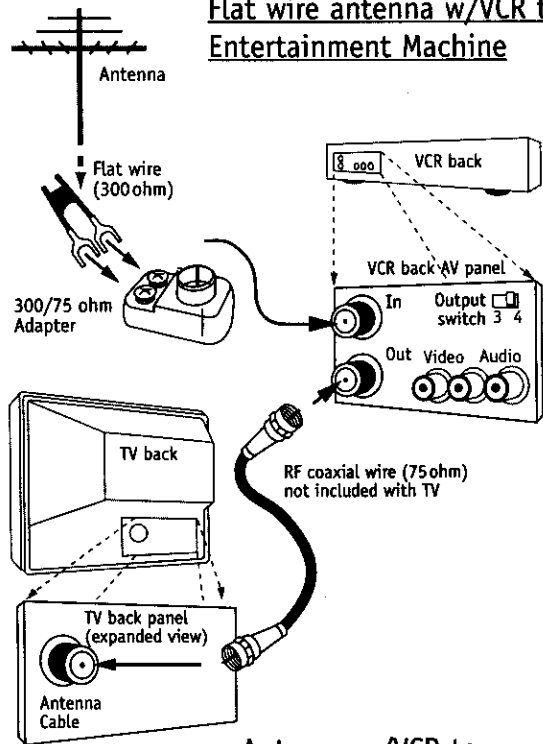

Antenna w/VCR to Entertainment Machine.

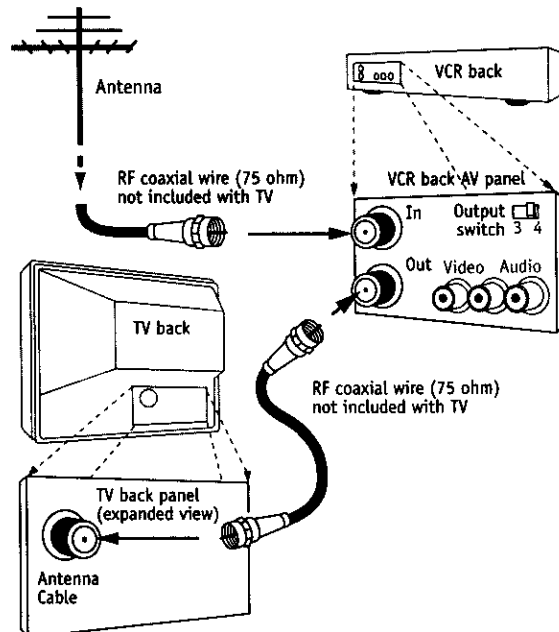

Hook Up Your Cable (CATV) and VCR

Connect cable service and a VCR to your Entertainment Machine.

1

Locate the Antenna/Cable jack on the back of your Entertainment Machine.

2

Connect the cable that runs from the wall directly to this jack, according to the diagram to the right.

3

Remove the back of the remote and put in two AA batteries.

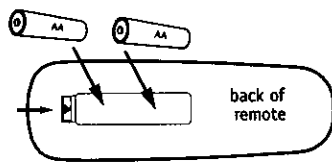

4

Plug in your TV. Do not plug it into a switched outlet. Your Entertainment Machine is designed to operate on household current, 120-volt 60 Hertz AC do not attempt to operate it on DC Current.

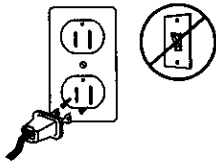

5

Go to page 10 to Auto Program your Entertainment Machine.

 Leave your VCR and your television tuned to channel three and use the cable box to change channels.

 Remember, when screwing in RF cables onto jacks, clockwise* tightens, and counterclockwise loosens.

 Without A/V cables, most VCRs will not play videocassettes in stereo sound.

Cable w/VCR to Entertainment Machine

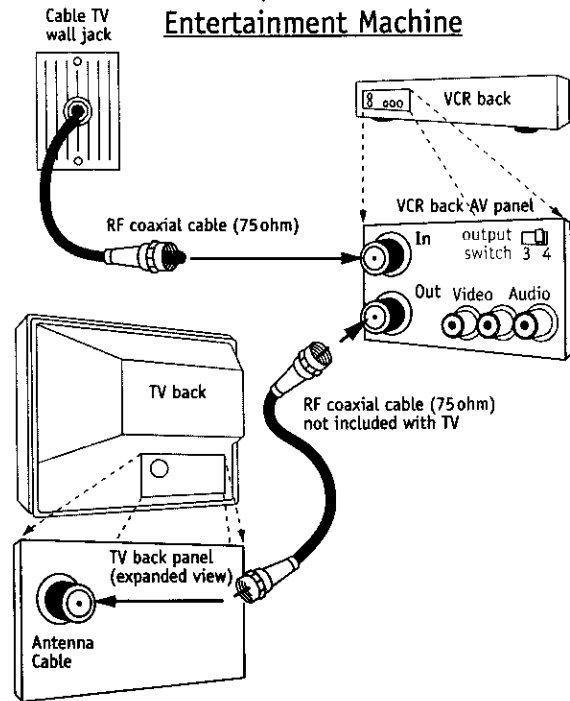

Cable w/Box to VCR and Entertainment Machine

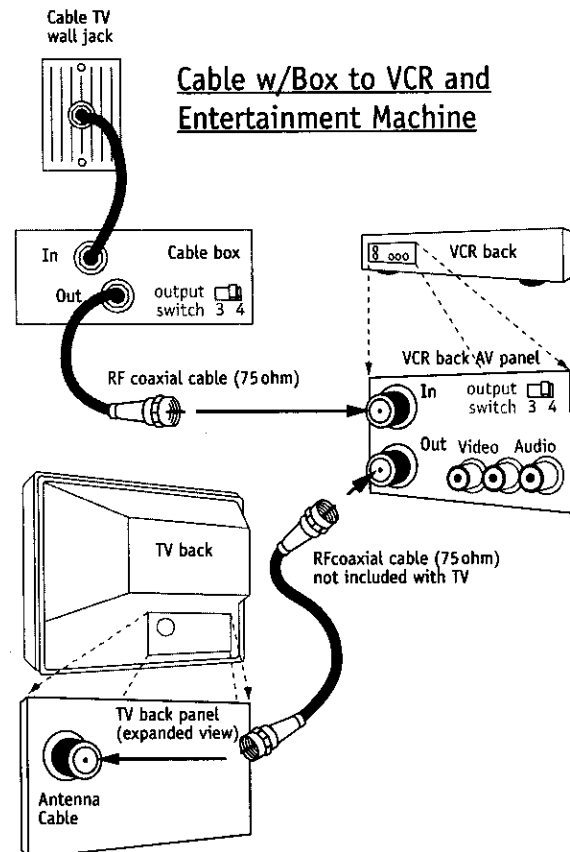

Auto Program

Use Auto Program to automatically find and store all of the stations available in your area.

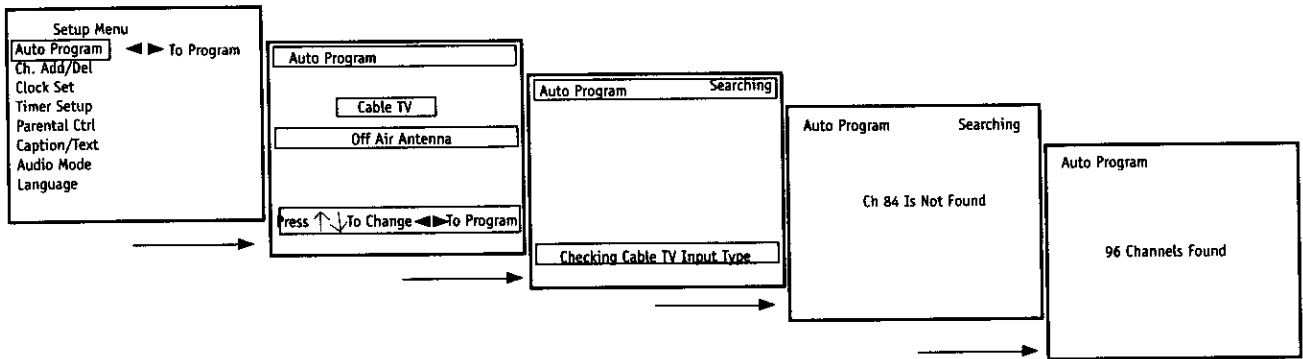

- 1 With the remote control in hand, press the POWER button to turn on your Entertainment Machine.
- 2 Press the MENU key so the Setup menu appears.
- 3 Using the UP/DOWN arrows on the remote control, select Auto Program on your screen.
- 4 Press a RIGHT or LEFT arrow to reach the Auto Program screen.
- 5 Using the UP/DOWN arrows, choose either Cable TV or Off-Air Antenna on your screen.
- 6 Press a RIGHT or LEFT arrow to begin Auto Program.
- 7 Press ENTER to return to TV viewing.

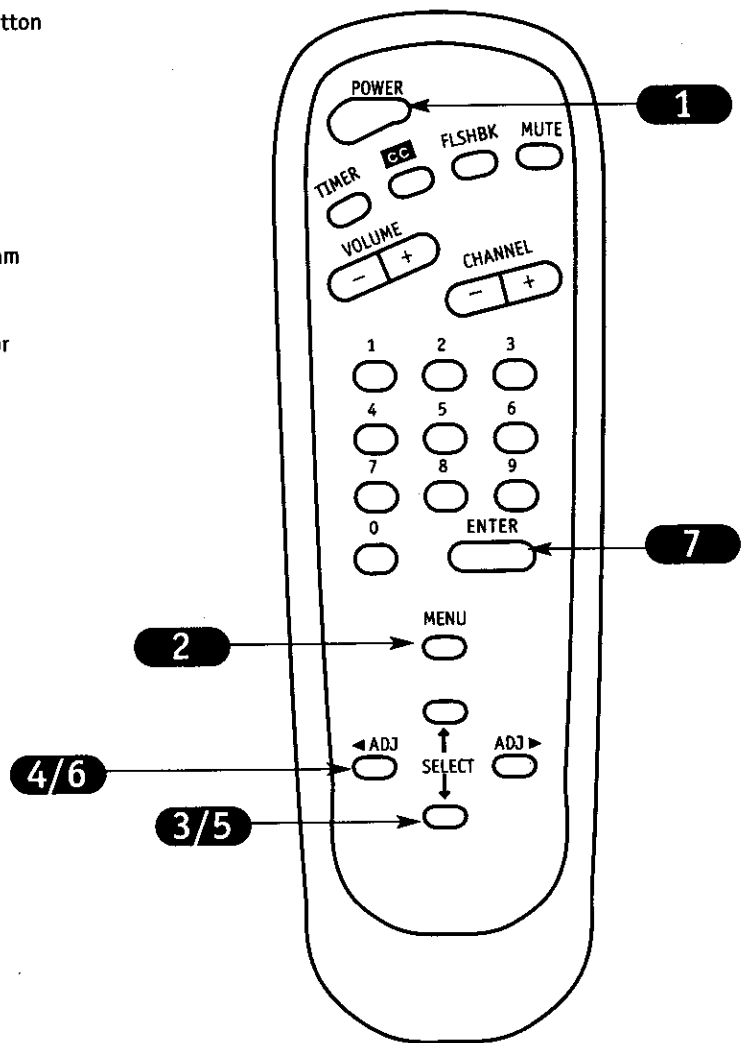

Auto Program

AUTO PROGRAM Auto Program is how your Entertainment Machine finds all the channels available in your area and stores them into memory.

The Buttons on Your Remote

A quick list of all of the buttons on the remote and what they do.

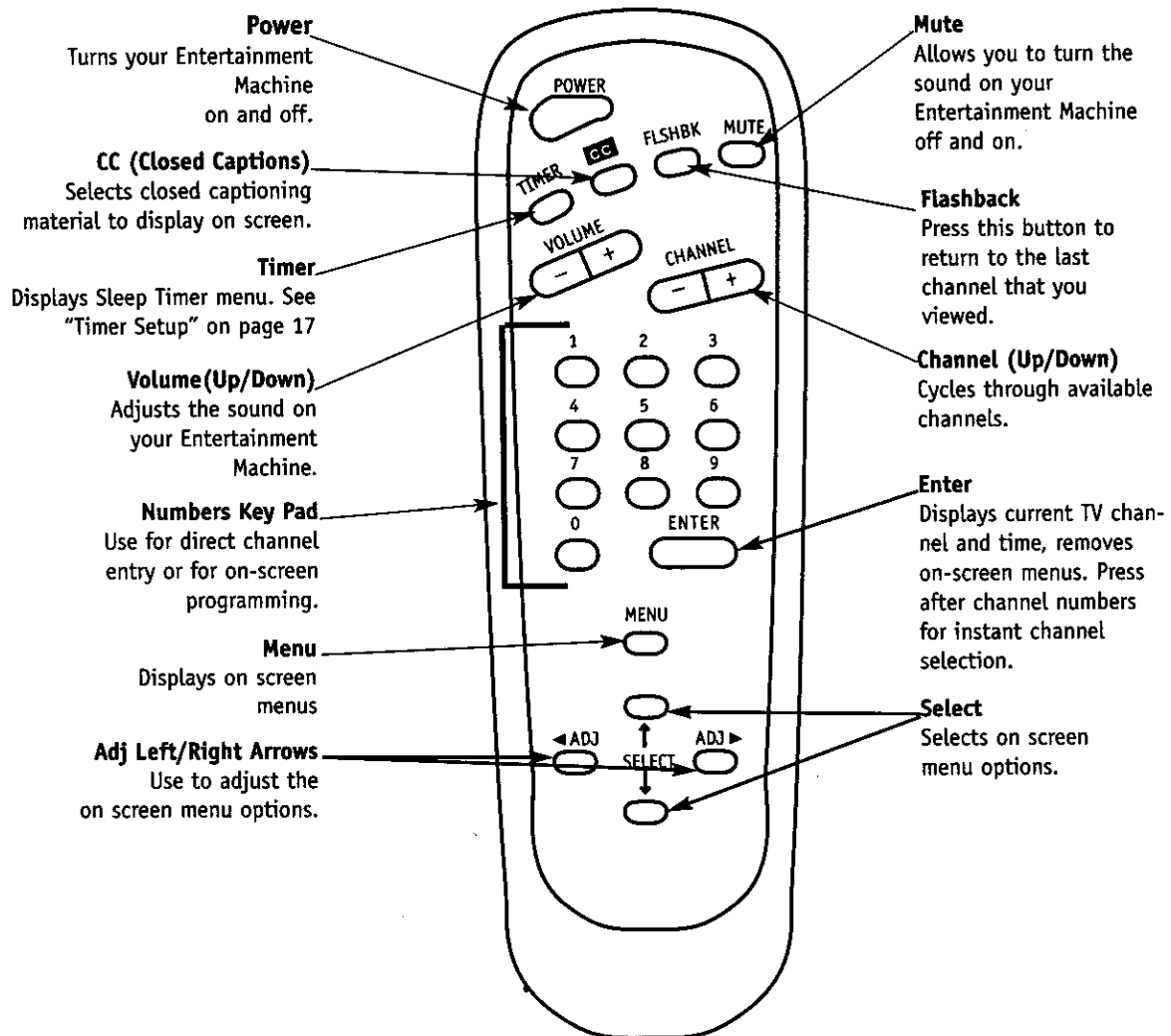

remote control part number
MBR3492Z
(124-213-23)

Front Panel Diagram

Here's how to use your six-button panel to operate the menus.

When using the on-screen menus, the buttons on the front panel correspond to the remote control buttons as follows: **VOLUME = Adjust Left/Right**
CHANNEL = Select Up/Down

1

To access the Setup menus, press the MENU button once; to get the Video menus, press the MENU button twice.

2

Choose the function you wish to change using the CHANNEL UP/DOWN buttons. The Channel buttons act as a "select" (Up/Down) function.

3

The VOLUME buttons act as an "adjustment" (Left/Right) function. Use the VOLUME buttons to make changes or adjustments.



Menus disappear after five seconds. To get them back, push the MENU button again.

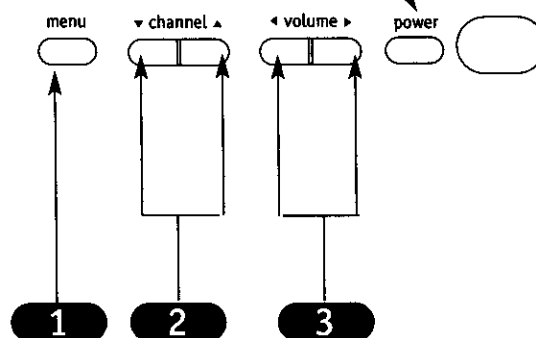
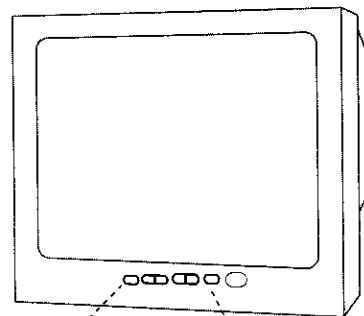

Basic Television Operation

Introducing you to the basics of your Entertainment Machine.

Source

On some models, the A/V input is designated as a channel that is one below the lowest/one above the highest.

You'll have to use the Channel Up/Down buttons to access it. The Time/Channel display will read "Video" in place of a channel number.

Cable/Antenna Input: This setting allows you to change cable or antenna channels and to view videocassettes on channel 3 (or 4) in mono sound.

Video Input: This setting allows stereo playback of videocassettes. The television cannot change channels in the Video mode, but the VCR can.



To view the current input source, press ENTER on your remote. The Time/Channel display should appear in the upper right hand corner of the screen. If the display reads 'Video,' then the source is an A/V input. If the display reads a channel number, then the source is your Cable or Antenna.

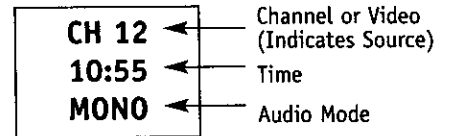

Channel Changing

CHANNEL UP/DOWN arrows: Use these arrows to change the channels. Auto program will have found all channels available to you.

NUMBER Key Pad: To skip to any channel, enter the number of the channel using the NUMBER key pad, then press ENTER.

FLASHBACK: To instantly return to the last channel viewed, press FLASHBACK.

Audio

Volume Right/Left: To adjust the volume level, use the volume Right/Left arrows. To silence your TV instantly, press MUTE. To get the sound back, press MUTE again.

Setup Menu

Here are descriptions of the menu options found in the Setup menu.

Function	What it does	Go to page
Auto Program	Automatically finds and stores active channels to flip through using Channel Up/Down.	10
Ch. Add/Del	Manually pick and choose which active channels will appear when flipping through using Channel Up/Down.	15
Clock Set	Sets the current time on your Entertainment Machine.	16
Timer Setup	Opens out menus for the following functions: * Turns the Sleep Timer on or off. * Selects an automatic ON TIME for your Entertainment Machine. * Selects an automatic OFF TIME for your Entertainment Machine. * On/Off Timer controls automatic power on and power off. NOTE: Timer must be set to ON for above functions to work.	17
Parental Ctrl	Allows you to block out any channels or sources for a designated period of time.	18
Captions/Text	Displays closed captions or text when available. Options are Off, Caption 1, Caption 2, Caption 3, Caption 4, Text 1, Text 2, Text 3, and Text 4.	20
Audio Mode	Set the audio to Stereo or Monaural.	21
Language	Selects language for on-screen menus. Your options are English, Spanish, or French.	22

Setup Menu

Auto Program

Ch. Add/Del

Clock Set

Timer Setup

Parental Ctrl

Caption/Text

Audio Mode

Language

4:34

PM

← FLASHBK

This is an example of what on-screen menus look like.

Setting Ch. Add/Del

Customize your channel selection.

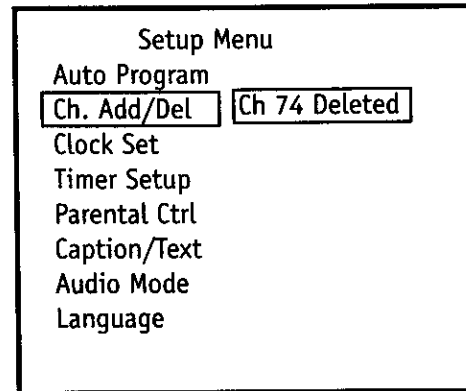
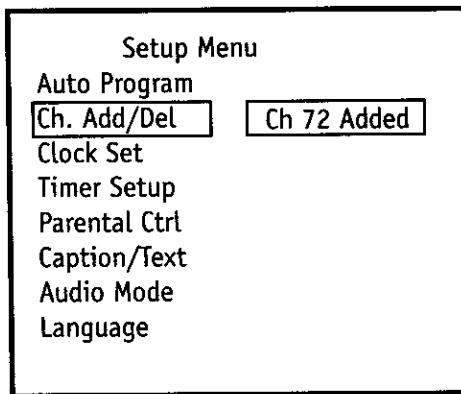

- 1 Press the MENU key on the remote so the Setup menu appears.
- 2 Select the Ch. Add/Delete menu using the UP/DOWN arrows.
- 3 Using either the NUMBER key pad or the CHANNEL UP/DOWN arrows on the remote, select a channel. (If adding a deleted channel, you will need to use the NUMBER key pad.)
- 4 Using the RIGHT/LEFT arrows, pick whether that channel is Added or Deleted.
- 5 To continue, select another channel and repeat step 4. If you are finished, press ENTER to return to TV viewing.



You can add or delete a channel without the remote control. Please refer to page 12 on working the menus with the buttons on the front of your Entertainment Machine.



If you delete a channel, it isn't gone for good. Just select it using the NUMBER key pad on the remote, or add it later.

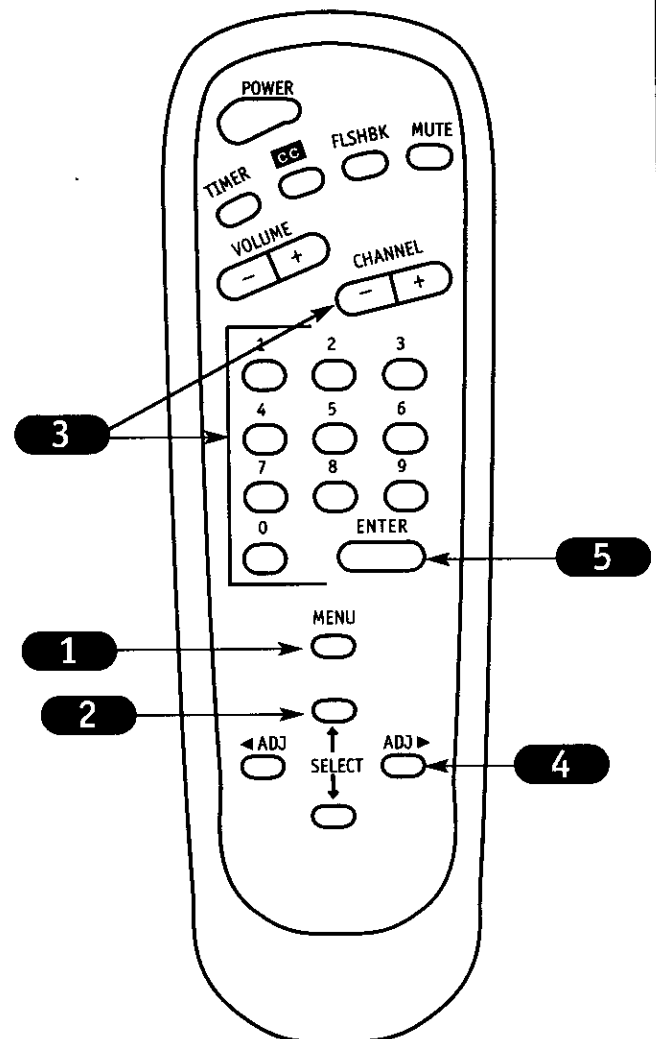

Channel Selection

- ADD** This function lets you add new channels to the list that you'll scroll through when using your remote.
- DELETE** This function lets you remove channels that you don't watch from the list you'll scroll through.

Clock Set

Set the clock on your Entertainment Machine.

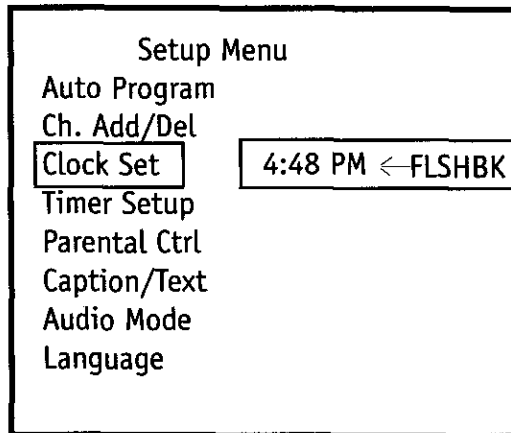

- 1 Press the MENU key on the remote control so that the Setup menu appears onscreen.
- 2 Using the UP/DOWN arrows on the remote control, select Clock Set on your screen.
- 3 Press a RIGHT or LEFT arrow to adjust the time.
- 4 Press the FLASHBACK button to select AM or PM.
- 5 Press ENTER to return to TV viewing.



You can use the NUMBER key pad to simply insert the time (AM or PM is still selected with the Flashback key).

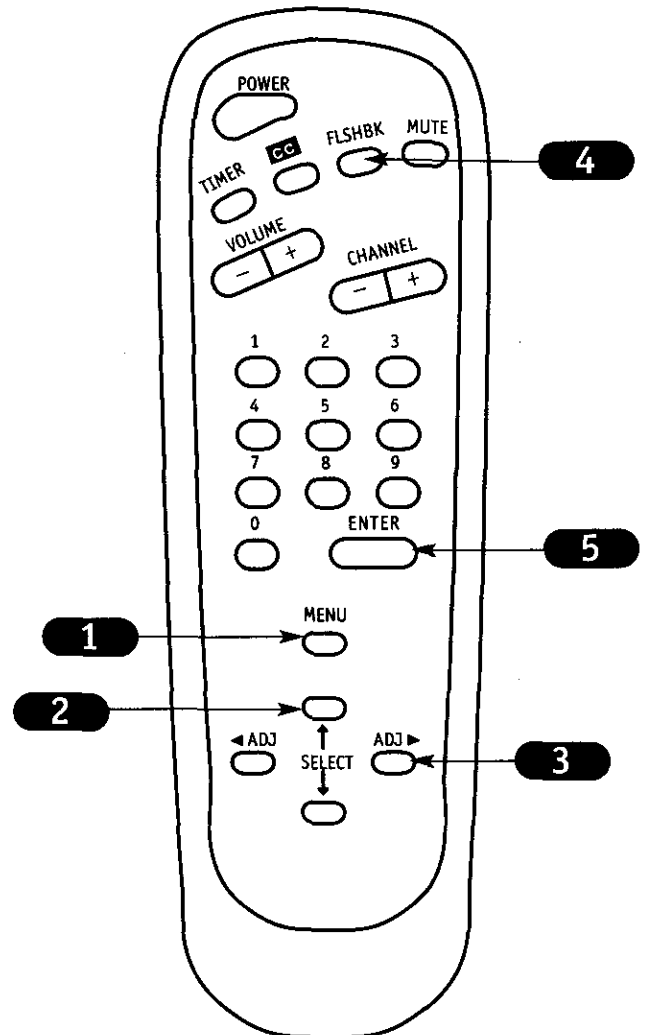

Timer Setup

Set your Entertainment Machine to turn itself on or off.

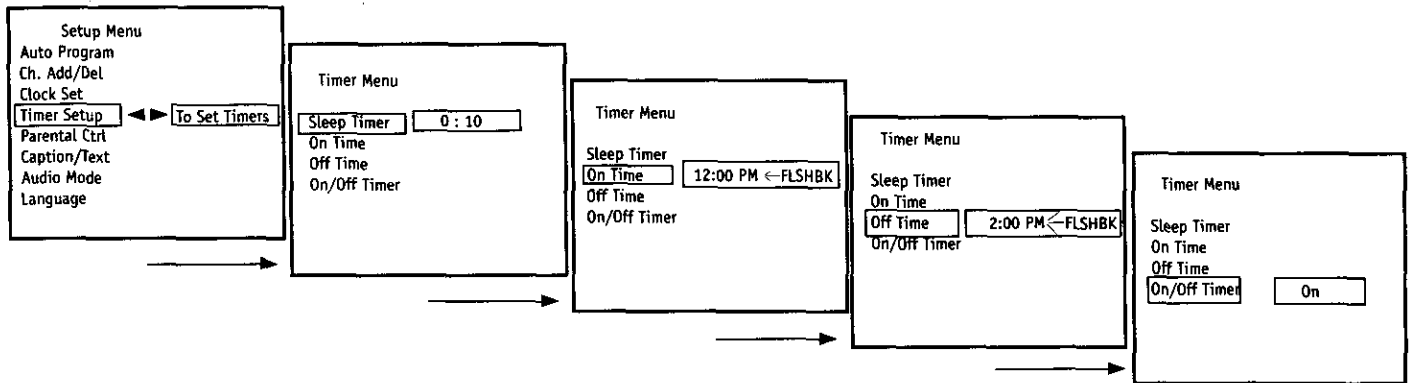

- 1 Press the MENU key on the remote control so that the Setup menu appears.
- 2 Using the UP/DOWN arrows on the remote control, select Timer Setup on your screen.
- 3 Press a RIGHT/LEFT arrow to set the time, from 10 minutes up to 4 hours.
- 4 Press ENTER to continue.
- 5 If you want the TV to turn itself On and Off automatically every day, use the UP/DOWN arrow keys, select ON TIME and use the RIGHT/LEFT keys to set the time you want the TV to turn itself on.
- 6 Once again, using the UP/DOWN arrow keys, select OFF TIME. Use the RIGHT/LEFT keys to set the time you want the TV to turn itself off.
- 7 Using the UP/DOWN arrow keys, select ON/OFF TIMER. Use the RIGHT/LEFT keys to select ON or OFF. The Timer feature is now set.
- 8 Press ENTER to return to normal viewing.

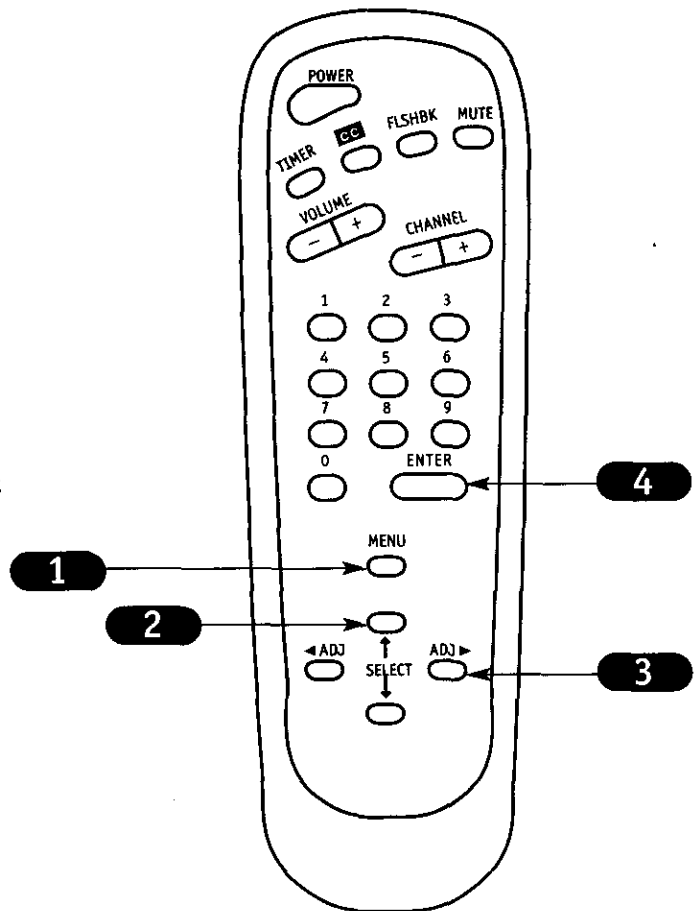

This feature offers a wide variety of options and settings that restrict or "block" undesirable programming from appearing on your TV screen.

AN OVERVIEW

Parental Control allows the user the capability of defining which program rating they consider acceptable to the younger or more sensitive viewer. It can be preset and turned either on or off by the user who specifies the secret 4-digit code. The number of hours blocked can be specified. General audience and children viewer blocks can both be programmed into the TV's memory. Viewer ratings are specified for both TV and the motion picture industry; both rating systems can be used. These ratings are based mainly on the ages of children.

Below are listed explanations of each of the blocking options and a guide to help you access and select the Parental Control option best suited for your viewing environment.

Aux. Block: Allows you to block the signal sent by equipment connected to the TV Audio/Video input jacks such as a VCR, a DVD Player, Laser Disc Player, etc. So, if you do not wish somebody to watch a videotape, a Laser Disc, etc, just set the Aux. Block to **Sources Blocked**.

MPAA: The Motion Picture Association of America's Rating system has been included for those people who may be more familiar with this rating system. (See layout on next page). There are six levels of settings. They are: **G and Above, PG and Above, PG-13 and Above, R and Above, NC-17 and Above and X**. Press to access.
NOTE: If you choose TV-PG, all of the more restrictive ratings will be automatically blocked. This means that the viewer will not be able to see TV-PG, TV-14, or TV-MA rated programming.

Age Block: You may wish to use these ratings instead. They are divided into two groups, General and Children.
GENERAL: These settings are: **TV-G and Above, TV-PG and Above, TV-14 and Above and TV-MA**.
CHILDREN: These settings are: **TV-Y and Above and TV-Y7**. Press to access.

Content Block: Once again, there are six designated blocks that you can access. They are: **Dialog, Language, Sex Scenes, Violence, F Violence and No Rating**. These settings allow you the option to block the program "Content" based on individual parameters such as: Strong Dialog, Bad Language, Sex Scenes, Violence Scenes or Fantasy Violence Scenes and then to select an age level as well. Press to access.

Set Hours: Use this setting to enter the amount of hours you wish the Advanced TV Control feature to be active.

Set Password: Select a secret password or code, using the number keys on the remote control. Don't forget the password. It is the only way you can access the Parental Control menu and change the rating selections. It is also the only way you can turn the Parental Control feature off.

Lock On Off: This setting gives you the option to have the Parental Control feature active all the time or allow you to turn it on or off as needed.



Simply specifying one content block such as Sex Scenes, will not automatically block another content in the programs from appearing.



Even if you choose to leave the Aux inputs unblocked, the ratings you specify will automatically restrict the programming that appears from the video sources.

Parental Control (continued)

Now let's block some programming and/or channels

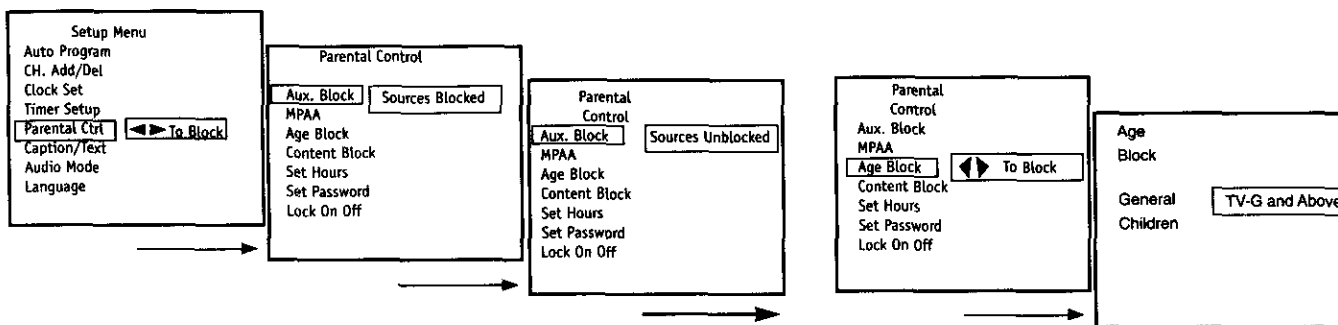

- 1 Press the MENU key on the remote control so that the Setup menu appears onscreen.
- 2 Using the UP/DOWN arrows on the remote control, select Parental Ctrl on your screen.
- 3 Press a RIGHT or LEFT arrow and a larger Menu with more specific and defined features will appear onscreen.
- 4 Press the UP/DOWN arrows on the remote control, to make a selection.
- 5 Press ENTER to return to TV viewing.

 You can set Parental Control for general audiences and for children to be active at the same time.

 You cannot disable Parental Control by disconnecting the TV from power. Blocked hours will automatically reset to the original blocked time setting specified, if power is disconnected.

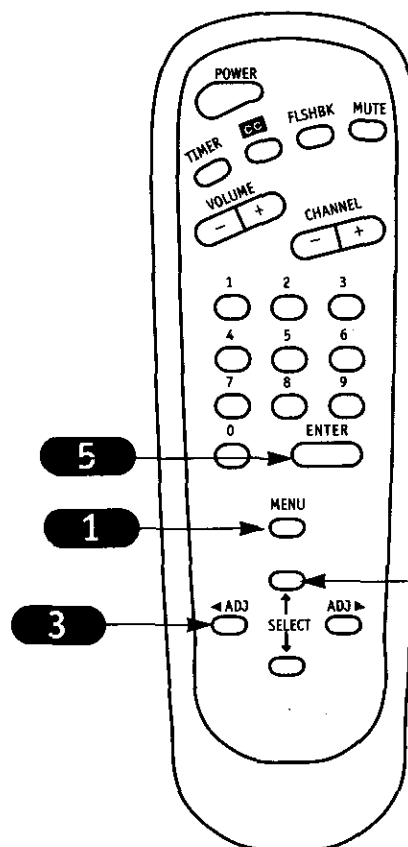

MOTION PICTURE ASSOCIATION OF AMERICA (MPAA) RATING SYSTEM

G	General Audiences	Content not offensive to most viewers.
PG	Parental Guidance Suggested	Content is such that parents may not want their children to view the program.
PG-13	Parental Guidance Suggested	Program is inappropriate for preteens, with a greater degree of offensive material than a PG rated program.
R	Restricted viewing	Not for children under age 17. Strong elements of sex and/or violence.
NC-17	Restricted Viewing	Not for children under age 17 under any circumstances. Strong sexual content.
X	Hard Core Films	Same as NC-17 rating.

Note: Zenith Electronics Corporation is not liable for any program content that appears when using this rating system; as always, user discretion is advised.

Captions and Text

Turn on closed captioning or text that appears at the bottom of your screen.

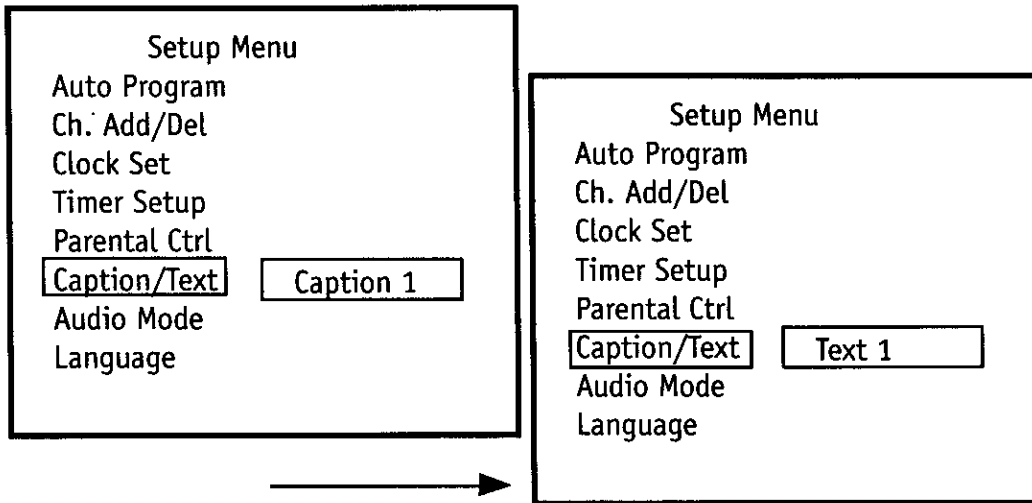

1

Press the MENU key on the remote control so that the Setup menu appears.

2

Using the UP/DOWN arrows on the remote control, select Captions/Text on your screen.

3

Press a RIGHT/LEFT arrow to choose any of the following options: Off, Caption 1, Caption 2, Caption 3, Caption 4, Text 1, Text 2, Text 3 or Text 4.

4

Press ENTER to return to TV viewing.



Captions come in handy when the television is on mute.



Standard Closed Captioning is available using the Caption 1 option.



Not all programming has closed captioning or text available.

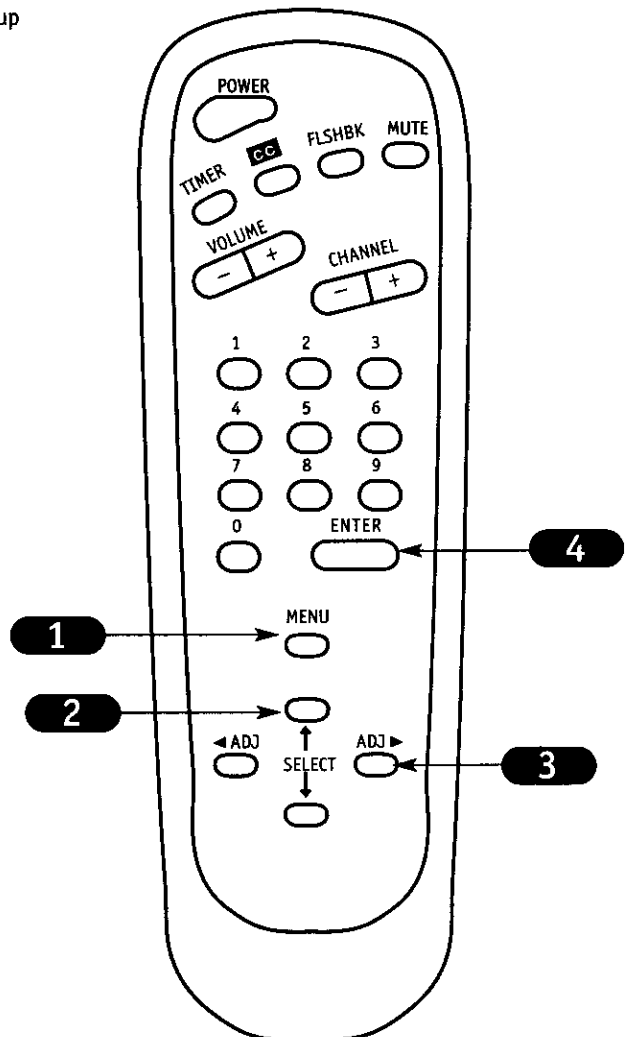

Audio Mode

Choose between Stereo and Mono sound.

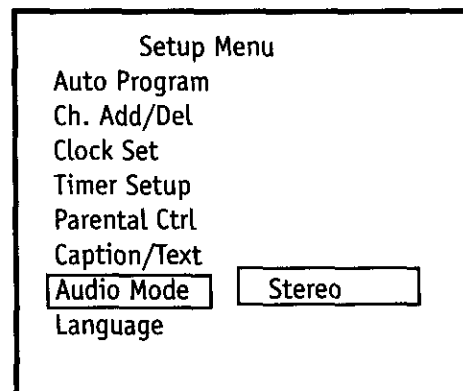
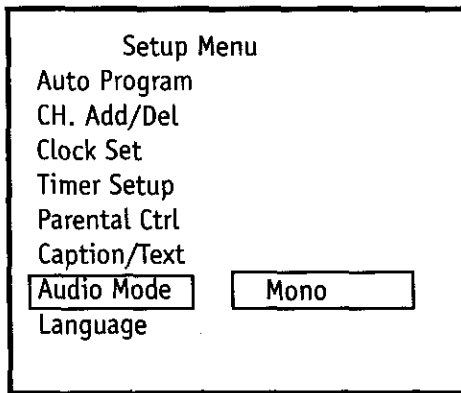

- 1 Press the MENU key on the remote control so that the Setup menu appears.
- 2 Using the UP/DOWN arrows on the remote control, select Audio Mode on your screen.
- 3 Press a RIGHT/LEFT arrow to choose any of the following options:
- 4 Press ENTER to return to TV viewing.



Not all programming is broadcast in stereo.

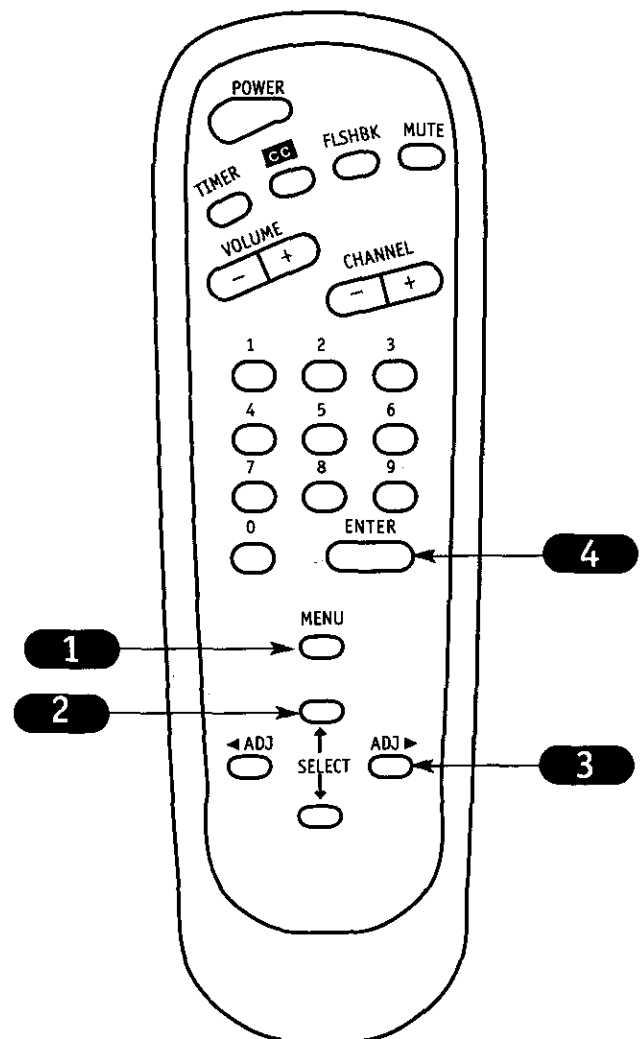

Language Options

Choose the language you want all of the menus to appear in.

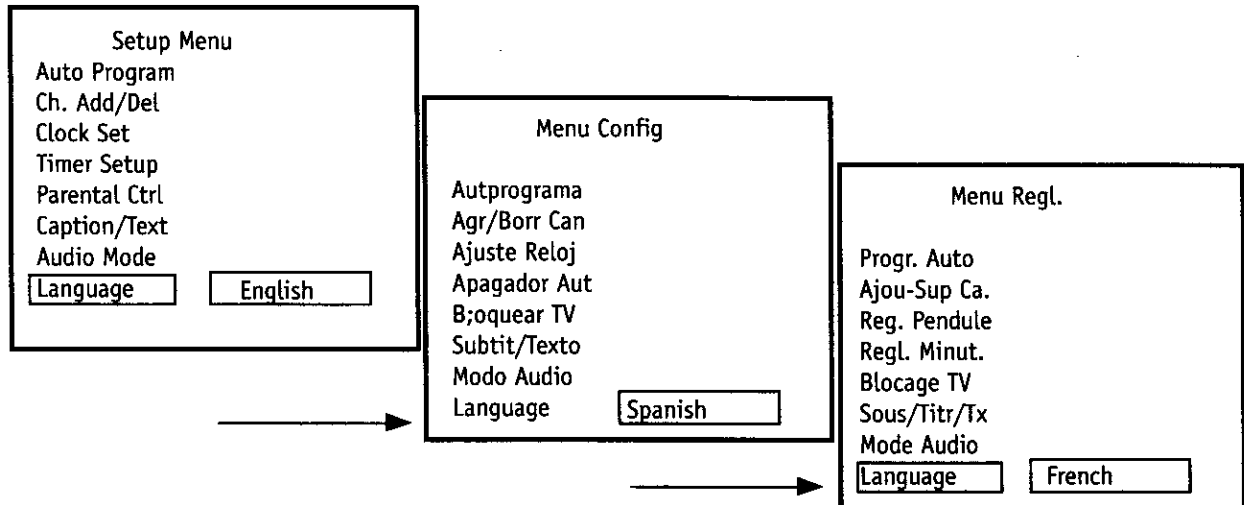

- 1 Press the MENU key on the remote control so that the Setup menu appears.
- 2 Using the UP/DOWN arrows on the remote control, select Language on your screen.
- 3 Press a RIGHT/LEFT arrow to choose any of the following options: English, Spanish, or French.
- 4 Press ENTER to return to regular TV viewing.

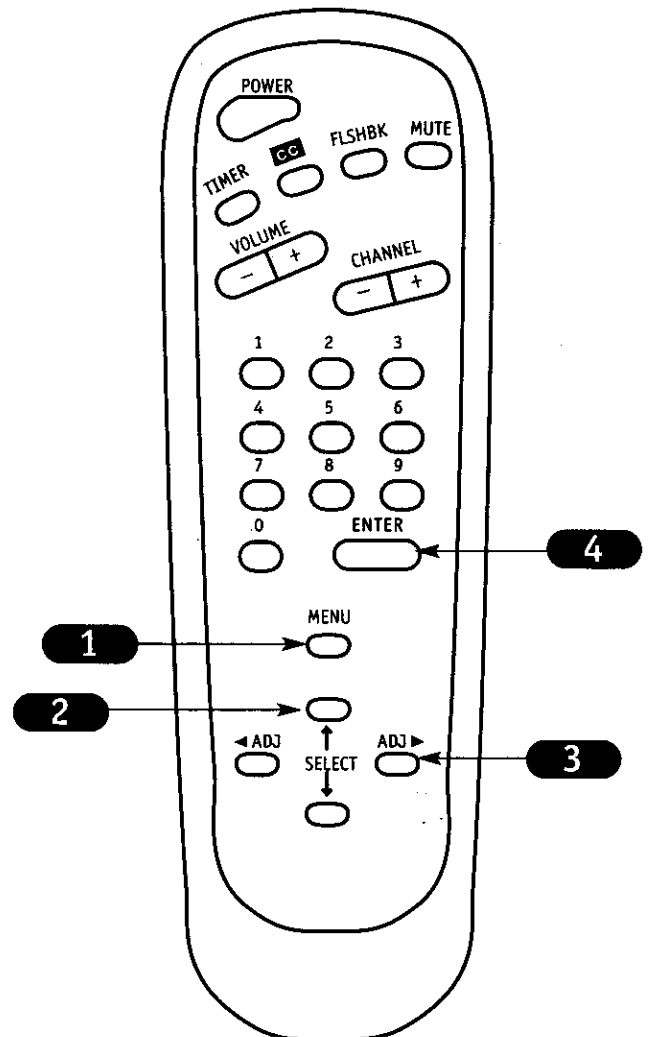

Video Menu

Customize the way your picture looks using the Video menu.

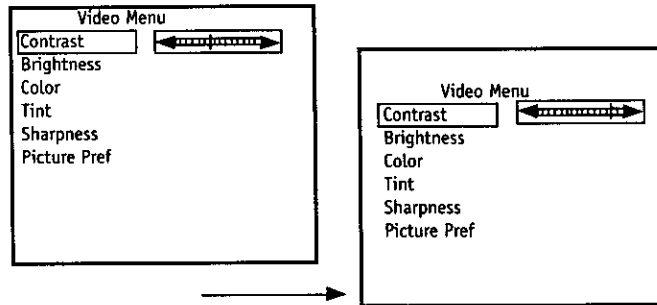

1 Press the MENU key twice and the Video menu will appear. Your options are:

- **Contrast:** Adjusts the level of difference between white and black in the TV picture. The more contrast, the brighter the picture appears.
- **Brightness:** Increases or decreases amount of white in the TV picture.
- **Color:** Adjusts levels of all colors in the TV picture.
- **Tint:** Balance between amount of red and green in the TV picture.
- **Sharpness:** Raise or lower the definition of the TV picture. The lower the level, the softer the images will appear.
- **Picture Preference:** Choose either Custom or Preset. Custom allows you to set the picture the way you want. Preset moves all the above options back to their original, factory-set levels.

2 Using the UP/DOWN arrows on the remote control, select Contrast on your screen.

3 Using the RIGHT/LEFT arrows, adjust the contrast level to your preference.

4 Press ENTER, QUIT or MENU one more time to return to TV viewing, or repeat from step four to set the other menu options.

5 Using the Up/Down arrow, select Picture Pref. on your screen.

6 Using the RIGHT/LEFT arrows, choose either the original settings with Preset or use your own settings with Custom.

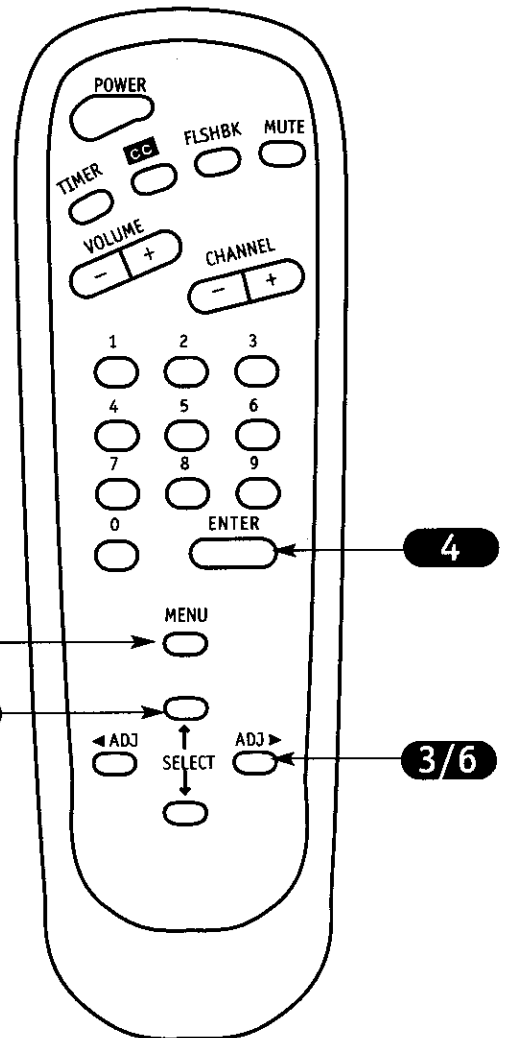

Troubleshooting

Some quick and easy tips to fixing problems yourself.

SYMPTOMS	SOLUTIONS
Snowy picture and poor sound.	<ul style="list-style-type: none">• Check your antenna connection or location.
Multiple images or 'ghost shadows.'	<ul style="list-style-type: none">• Check your antenna direction and/or location.• Make sure the wire from your antenna to your Entertainment Machine is properly connected.
Interference: Sharp lines across the screen and poor sound.	<p><i>The following may cause image problems or distortion: Electrical appliances, powerful lights, cars, trucks; computers or portable phones; medical equipment</i></p> <ul style="list-style-type: none">• If possible increase the distance between your Entertainment Machine™ and the offending appliance. Or shut one of them off.
Normal picture but no sound.	<ul style="list-style-type: none">• Check volume control.• Make sure the TV is not Muted.• Try another channel. The problem may be the broadcast, not your Entertainment Machine™.• Are the Audio A/V cables properly installed?• Are the wires for external speakers (if you have external speakers) properly installed?
No picture and poor sound.	<ul style="list-style-type: none">• Are you in TV or cable tuning mode and should be in the other?• Make sure output channels on all A/V equipment are on the same channel (3 or 4).• Check that all connections are tight.
No picture and no sound	<ul style="list-style-type: none">• Is the AC power plugged in?• Check that your AC power outlet works. (Test it by plugging in something else or try another plug.)• Make sure your brightness and audio controls are set properly.• Try another channel. The problem may be with the broadcast.
No color, but the sound is O.K.	<ul style="list-style-type: none">• Check the color control in the Video menu.• Try another channel. The problem may be with the broadcast.
Picture has a big black box on it, but the sound is O.K.	<ul style="list-style-type: none">• The CC (closed caption) option may be in Text mode. Select OFF in the Captions/Text menu.
Picture has two horizontal black bars, one on top and one on bottom.	<ul style="list-style-type: none">• Your program is in letterbox. This means that the shape of your TV is a square, but the program is a rectangle. Think of the bars as empty space the program doesn't fill; not picture that's blocked out. Because this format is a direct representation of film as you see it in the movies, you are actually seeing MORE of the program when you see those bars. Trust us.
Remote control doesn't work.	<ul style="list-style-type: none">• Make sure the batteries are fresh and installed properly.• Remove the batteries for 30 seconds and replace.
Menu options won't change.	<ul style="list-style-type: none">• Try unplugging the TV, waiting about five minutes, and then plugging it back in and trying again.

75 OHM RF CABLE	The wire that comes from an off-air antenna or cable service provider. The end looks like a hex-shaped nut with a wire sticking through the middle. It screws onto the threaded jack on the back of your TV.
300 TO 75 OHM ADAPTER	A small device that connects a two-wire 300 ohm antenna to a 75 ohm RF jack. They are usually about an inch long with two screws on one end and a round opening with a wire sticking out on the other end.
A/V CABLES	Audio/Video cables. Three cables bunched together—right audio (red), left audio (white), and video (yellow). A/V cables are used for stereo playback of videocassettes and for higher quality picture and sound from other A/V devices.
ADD	This function lets you add new channels to list that you'll scroll through when using your remote.
ANTENNA	The physical receiver of television signals sent over the air. A large metal piece of equipment does not always have to be visible for your home to be using an antenna.
AUTO PROGRAM	Auto Program has your Entertainment Machine automatically find all the channels available in your area.
BLOCK	Restrict or censor a channel for a set length of time.
DELETE	This function lets you remove channels that you don't watch from the list you'll scroll through using your remote.
INPUT	Refers to the jack that receives a signal from a TV, VCR or other A/V device.
JACK	A connection on the back of a TV, VCR, or any other A/V device.
MONO SOUND	Mono (monaural) sound is one channel of sound. On more than one speaker, all the speakers play the same audio.
OUTPUT	Refers to the jack that sends a signal out of a VCR, DVD, or other A/V device.
SECOND AUDIO PROGRAMMING/SAP	Second Audio Programming (SAP) is another, separate, audio channel available with some programming. Choosing SAP often refers to listening to audio in another language, such as Spanish or French.
SIGNAL	Picture and sound traveling through cable, or on the air, to your television screen.
STEREO SOUND	Stereo (stereophonic) sound refers to audio that's divided into right and left sides.
TUNER	Device that picks up the signal and turns them into picture and sound.

Maintenance

Caring for your Entertainment Machine.

Early malfunctions can be prevented. Careful and regular cleaning can extend the amount of time you will have with your new Entertainment Machine. Be sure to turn the power off and pull out the plug before you begin any cleaning.

Screen Cleaning

1. Here's a great way to keep the dust off your screen for a while. Wet a soft cloth in a mixture of lukewarm water and a little fabric softener or dish washing detergent. Wring the cloth until it's almost dry, and then use it to wipe the screen.
2. Make sure the excess water is off the screen, and then let it air-dry before you turn on your Entertainment Machine.

Cabinet Cleaning

1. Use a soft cloth with a mild soap solution to wipe the cabinet (avoid using any cleaner that says "industrial strength" or "will wash the white off of rice" on the label).
2. Rinse the cloth and wipe the cabinet again.
3. Let the cabinet air-dry before turning the Entertainment Machine on.

Wood Cabinets

Use a quality wood cleaner and polish. This will protect the Entertainment Machine from dirt and dust, as well as keep the cabinet looking new.

Extended Absence

If you leave your Entertainment Machine dormant for a long time (such as a vacation), it's a good idea to unplug the power to protect against possible damage from lightning or power surges. If you use an off-air antenna, you may also want to disconnect it from the back of your TV before leaving.

Find what you want quickly.

FEATURE	PAGE
Antenna	6, 8
Audio Mode	21
Auto Program	10
Basic Television Operation	13
Batteries	6-9, 24
Button Functions	11, 12
Cable	7, 9
Captions and Text Menu	20
Ch. Add/Del	15
Clock Set	16
Front Panel Diagram	12
Glossary	25
Hook-Up Directory	5
Language Menu	22
Maintenance	26
Parental Control	18, 19
Remote Control Diagram	11
Safety Information	2,3,4
Setup Menu	14
Timer	17
Troubleshooting	24
VCR	8,9
Video Menu	23
Warranty	29

Recommended Video Accessories

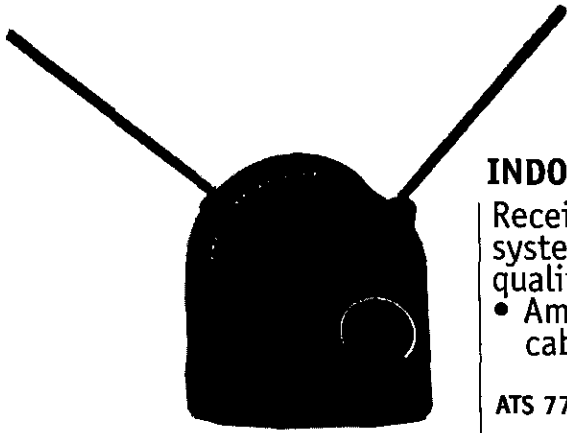

INDOOR AMPLIFIED ANTENNA

Receive Local programming NOT available on your Satellite system!!! Perfect backup antenna for cable outages. Enhanced quality picture and stereo sound in weak signal areas.

- Amplified VHF/UHF/FM Antenna includes 4 feet of 75 ohm cable for easy hookup.

ATS 775 **ONLY \$34.95** PLUS \$6.95 SHIPPING & HANDLING

TELEVISION WALL MOUNTS

Set up your game room or spare room in style!! Sturdy black wall mounts keep the TV off your furniture and in easy view. All mounts have 90 degree and 10 degree tilt angles.

- ALGW27 fits most 25" to 27" TVs - **ONLY \$59.99**
- ALGW20 fits most 19" and 20" TVs - **ONLY \$49.99**
- ALGW13 fits most 13" Televisions - **ONLY \$39.99**

Available in White, just add "-WH" to part number (e.g. ALGW27-WH)

FOR ALL ORDERS ADD \$6.95
SHIPPING & HANDLING

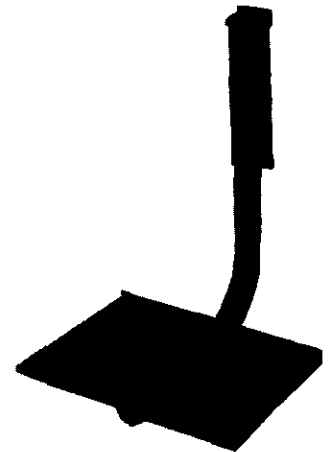

ZENITH 5 FUNCTION REMOTE

Broken or lost remote? Need a second remote or more functions? Order direct from Zenith!!

- Operates TV, VCR, CD, DVD, DIVX, DSS & Cable Box
- Operates PIP and Most Screen Menus
- Extended Range & MORE!!!

Orders 1 year or more after product purchase may receive upgraded models. Other Remotes with 3, 4, 5 & 7 Functions Available Upon Request

ZEN 525 **ONLY \$19.99** PLUS \$6.95 SHIPPING & HANDLING

zenith



ORDER TODAY!
CALL OR FAX TOLL-FREE
1.800.255.6790

Fax 1.888.693.6484

email: parts.sales@zenith.com

Use Your Visa or MasterCard to Order



PLEASE ALLOW 3-4 WEEKS FOR DELIVERY



Your Zenith Warranty

Direct-View Color TV Welcome into the Zenith family! We believe that you will be pleased with your new Zenith Entertainment Machine. Please read this warranty carefully, it is a "LIMITED WARRANTY" as defined under Federal Law. This warranty gives you specific legal rights, and you may also have other rights that vary from state to state within the U.S.A.

ZENITH RESPONSIBILITY

- Service Labor** During a period of 90 days from effective warranty date, Zenith will provide service labor by a Zenith authorized service center when needed as determined by Zenith, as a result of manufacturing defects.
- Parts** New or remanufactured replacements for factory-defective parts will be supplied by a Zenith authorized service center for one year from effective warranty date (color picture tube — two years). Such replacement parts are warranted for the remaining portion of the original warranty period.
- Home Service** Warranty service for 21" diagonal (U.S.A.) or larger screen size models is provided in the home in most cases. (Some repairs may require the unit to be taken by the servicer to the repair facility and returned, at no additional charge.)
- Not Covered** This warranty covers manufacturing defects and does not cover installation, adjustment of customer controls in the home, installation or repair of home antenna systems, cable converters or cable company-supplied equipment; it also does not cover damage due to misuse, abuse, negligence, acts of God or other causes beyond the control of Zenith. Any alteration of the product after manufacture voids this warranty in its entirety.

THIS WARRANTY IS IN LIEU OF ANY OTHER WARRANTY, EXPRESS OR IMPLIED, INCLUDING WITHOUT LIMITATION, ANY WARRANTY OF MERCHANTABILITY OR FITNESS FOR A PARTICULAR PURPOSE, AND ZENITH SHALL NOT BE LIABLE FOR ANY CONSEQUENTIAL, INDIRECT, OR INCIDENTAL DAMAGES OF ANY KIND, INCLUDING LOST REVENUES OR PROFITS IN CONNECTION WITH THE PRODUCT. SOME STATES DO NOT ALLOW LIMITATIONS ON HOW LONG AN IMPLIED WARRANTY LASTS OR THE EXCLUSION OR LIMITATION OF INCIDENTAL OR CONSEQUENTIAL DAMAGES, SO THE ABOVE LIMITATIONS OR EXCLUSIONS MAY NOT APPLY TO YOU.

OWNER'S RESPONSIBILITY

- Effective Warranty Date** Warranty begins on the date of original consumer purchase. For your convenience, keep the dealer's dated bill of sale or delivery ticket as evidence of the purchase date.
- Operating Guide** Read your Operating Guide carefully so that you will understand the operation of your set and how to adjust the customer controls.
- Carry-In Service** Models under 21" diagonal (U.S.A.) screen size must be taken to a Zenith authorized service center for warranty service and must be picked up by the owner.
- Antenna** Reception problems caused by inadequate home antenna or faulty antenna connections are the owner's responsibility.
- Important** Product Registration—Please fill out and mail your Product Registration Card. It is imperative that Zenith know how to reach you promptly if we should discover a safety problem that could affect you.
- Warranty Service** For warranty service information, contact any Zenith authorized service center. Parts and service labor that are Zenith's responsibility (see above) will be provided without charge. Other service is at the owner's expense. If you have any problem in obtaining satisfactory warranty service, call or write the Zenith Response Center. You must provide the model number, serial number and date of purchase or date of original installation. Before you ask for warranty service, read "Maintenance and Troubleshooting" in your operating guide. You might avoid a service call.

ZENITH ELECTRONICS CORPORATION Zenith Response Center

201 James Record Rd., Building 3,
Huntsville, AL 35824
Telephone (256) 772-1515
Mon-Fri, 7:00 a.m.-8:00 p.m. CST
Sat. 8:00 a.m.-5:00 p.m. CST
www.zenith.com

ZENITH CONSUMER SERVICES FACTORY OWNED SERVICE CENTERS

801 E. Roosevelt Rd
Lombard, IL 60148
(630)705-2830

Home & Carry-in Service
Television/VCR
Parts and Accessories
PTV/Camcorders

201 James Record Rd.
Building 4
Huntsville, AL 35824
(256) 774-4025

Service Hours:
M-F 8-6, Sat 9-2
Will accept UPS Shipments

Additional Zenith Picture Tube Protection Plan Available

Zenith offers you the opportunity to obtain additional long-term protection against failure of the picture tube in your new Entertainment Machine. Our Picture Tube Protection Plan enables you to avoid any unexpected picture tube repair expenses and keep your Entertainment Machine in top condition. It guarantees you a genuine Zenith replacement picture tube and service from a Zenith authorized service center.



Be sure to send in the Product Registration Card. We will send you an application for the Protection Plan near the expiration of the two-year manufacturer's warranty on the picture tube. For additional information call (256) 774-4088.

