

Panasonic®

Palmcorder® PalmSight™

Camcorder

Operating Instructions

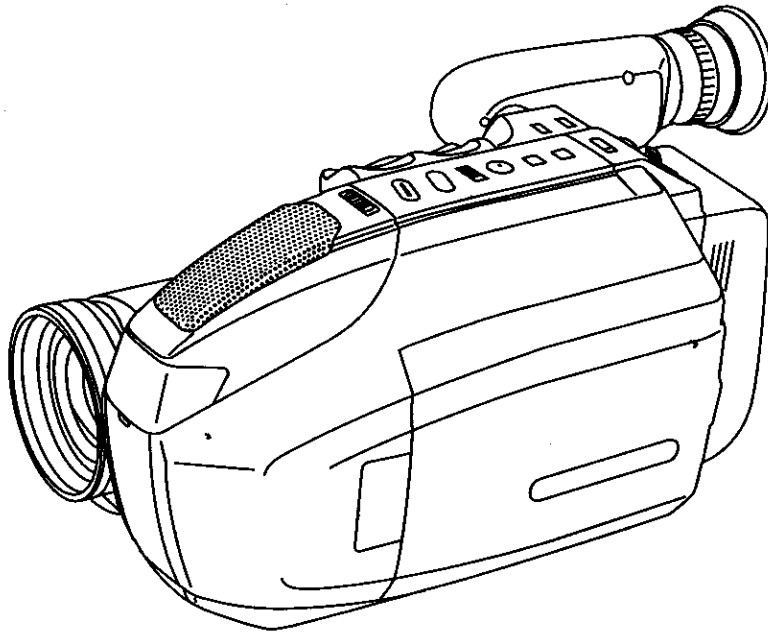

Copied _____
Entered _____
LIS NRPOS _____
Received 5-24-99 _____
Scanned _____
Batch # _____

VHS

PV-L779

300x / 26x
DIGITAL HI-DEF
ZOOM

4.0"
COLOR LCD
MONITOR

DIGITAL
STILL
CAMERA
BUILT-IN

DIGITAL
EIS
STABILIZATION

FULL-SIZE
DEDICATED
5
HEAD

2hr.
BATTERY

Please read these instructions carefully before attempting to operate this product.
Please save this manual.

Guía para rápida consulta en español está incluida.

For assistance, call 1-800-211-PANA(7262)

VQTW0746A

Start

Basic Operation

Special Features

For more information

Things You Should Know

Thank you for choosing Panasonic!

You have purchased one of the most sophisticated and reliable products on the market today. Used properly, it will bring you years of enjoyment. Please take time to fill in the information at the right. The serial number is on the tag located on the underside of your Camcorder. Be sure to **retain this manual** as your convenient Camcorder information source.

Date of Purchase

Dealer Purchased From

Dealer Address

Dealer Phone No.

Model No.

Serial No.

Unpack your Camcorder

These accessories are provided in order to set up or use your Camcorder.

1 pc. AC Adaptor (PV-A17)
with DC Power Cable
(page 13)

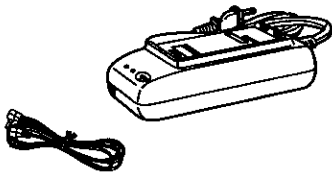

1 pc. Battery Pack (PV-BP18)
(pages 11, 12)



1 pc. Audio/Video Cable
(VJAW0027/VJAW0032/
VJAW0039) (pages 30, 32)

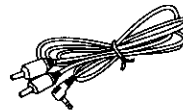

1 pc. VHS PlayPak
(PV-P1/VYMW0009) and
one "AA" battery (page 31)

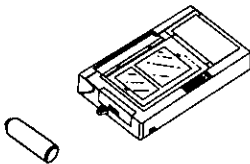

1 pc. Shoulder Strap
(VYCW0225) (page 15)



1 pc. CR2025 Clock Battery
(VSBW0004)
(installed in Camcorder)
(page 74)



1 pc. Driver Software Floppy
Disk for Windows 95/98
(VFTW0013) (page 62)



1 pc. PC Connection cable
(RS232C-3P)
(LSJA0185/LSJA0190)
(page 61)

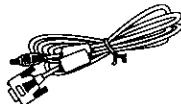

1 pc. CompactFlash Card
[2MB] (LSFA0005) (page 51)



CompactFlash Card is a trademark of SanDisk Corporation.

Microsoft, Windows, and Windows 95/98 are registered trademarks of Microsoft in the United States and other countries.

All product/brand names are trademarks or registered trademarks of the respective holders.

Things You Should Know



Safety Precautions

WARNING: TO PREVENT FIRE OR SHOCK HAZARD, DO NOT EXPOSE THIS EQUIPMENT TO RAIN OR MOISTURE.

Your Compact VHS Camcorder is designed to record and play back in Standard Play (SP) and Super Long Play (SLP) modes. You can also play a Compact VHS Camcorder recording on your VHS VCR using the VHS PlayPak supplied.

This Camcorder is equipped with the HQ System to provide excellent video pictures, and is compatible with standard VHS equipment.

It is recommended that only cassette tapes that have been tested and inspected for use in VCR machines with the **VHS-C** and/or **VHS** mark be used.

 CAUTION RISK OF ELECTRIC SHOCK DO NOT OPEN		This symbol warns the user that uninsulated voltage within the unit may have sufficient magnitude to cause electric shock. Therefore, it is dangerous to make any kind of contact with any inside part of this unit.
CAUTION: TO REDUCE THE RISK OF ELECTRIC SHOCK, DO NOT REMOVE COVER (OR BACK) NO USER-SERVICEABLE PARTS INSIDE REFER SERVICING TO QUALIFIED SERVICE PERSONNEL		This symbol alerts the user that important literature concerning the operation and maintenance of this unit has been included. Therefore, it should be read carefully in order to avoid any problems.

The above markings are located on the appliance bottom cover.

FCC Warning: To assure continued FCC compliance, the user must use only provided shielded interfacing cable with ferrite cores when connecting to computer. Also, any unauthorized changes or modifications to this equipment would void the users authority to operate.

This device complies with Part 15 of the FCC Rules. Operation is subject to the following two conditions: (1) This device may not cause harmful interference, and (2) this device must accept any interference received, including interference that may cause undesired operation.

Note: This equipment has been tested and found to comply with the limits for a Class B digital device and a RF Lighting device, pursuant to part 15 and Part 18 of the FCC Rules.

These limits are designed to provide reasonable protection against harmful interference in a residential installation. This equipment generates, uses and can radiate radio frequency energy and, if not installed and used in accordance with the instructions, may cause harmful interference to radio communications. However, there is no guarantee that interference will not occur in a particular installation. If this equipment does cause harmful interference to radio or television reception, which can be determined by turning the equipment off and on, the user is encouraged to try to correct the interference by one or more of the following measures:

- Reorient or relocate the receiving antenna.
- Increase the separation between the equipment and receiver.
- Connect the equipment into an outlet on a circuit different from that to which the receiver is connected.
- Consult the dealer or an experienced radio/TV technician for help.

Important Safeguards

1. **Read Instructions** — All the safety and operating instructions should be read before the unit is operated.
2. **Retain Instructions** — The safety and operating instructions should be retained for future reference.
3. **Heed Warnings** — All warnings on the unit and in the operating instructions should be adhered to.
4. **Follow Instructions** — All operating and maintenance instructions should be followed.
5. **Cleaning** — Unplug this video unit from the wall outlet before cleaning. Do not use liquid or aerosol cleaners. Use a dry cloth for cleaning.
6. **Attachments** — Do not use attachments not recommended by the video product manufacturer as they may be hazardous.
7. **Water and Moisture** — Do not use this video unit near water — for example near a bath tub, wash bowl, kitchen sink, or laundry tub, in a wet basement, or near a swimming pool, and the like.
8. **Accessories** — Do not place this video unit on an unstable cart, stand, tripod, bracket, or table. The video unit may fall, causing serious injury to a child or adult, and serious damage to the unit. Use only with a cart, stand, tripod, bracket, or table recommended by the manufacturer, or sold with the video unit. Any mounting of the unit should follow the manufacturer's instructions and should use a mounting accessory recommended by the manufacturer. An appliance and cart combination should be moved with care. Quick stops, excessive force, and uneven surfaces may cause the appliance and cart combination to overturn.
9. **Ventilation** — Slots and openings in the cabinet are provided for ventilation and to ensure reliable operation of the video unit and to protect it from overheating. These openings must not be blocked or covered. Never place the video unit on a bed, sofa, rug, or other similar surface, or near or over a radiator or heat register. This video unit should not be placed in a built-in installation such as a bookcase or rack unless proper ventilation is provided or the manufacturer's instructions have been adhered to.
10. **Power Sources** — This video unit should be operated only from the type of power source indicated on the marking label. If you are not sure of the type of power supply to your home, consult your appliance dealer or local power company. For video units intended to be operated from battery power, or other sources, refer to the operating instructions.



11. **Grounding or Polarization** — This video unit may be equipped with either a polarized 2-wire AC (Alternating Current) line plug (a plug having one blade wider than the other) or 3-wire grounding type plug, a plug having a third (grounding) pin. The 2-wire polarized plug will fit into the power outlet only one way. This is a safety feature. If you are unable to insert the plug fully into the outlet, try reversing the plug. If the plug still fails to fit, contact your electrician to replace your obsolete outlet. Do not defeat the safety purpose of the polarized plug. The 3-wire grounding type plug will fit into a grounding type power outlet. This is a safety feature. If you are unable to insert the plug into the outlet, contact your electrician to replace your obsolete outlet. Do not defeat the safety purpose of the grounding type plug.
12. **Power-Cord Protection** — Power-supply cords should be routed so that they are not likely to be walked on or pinched by items placed upon or against them. Paying particular attention to cords of plugs, convenience receptacles, and the point where they exit from the unit.
13. **Outdoor Antenna Grounding** — If an outside antenna or cable system is connected to the video unit, be sure the antenna or cable system is grounded so as to provide some protection against voltage surges and built-up static charges. Part 1 of the Canadian Electrical Code, in USA Section 810 of the National Electrical Code, provides information with respect to proper grounding of the mast and supporting structure, grounding of the lead-in wire to an antenna discharge unit, size of grounding conductors, location of antenna discharge unit, connection to grounding electrodes, and requirements for the grounding electrode.

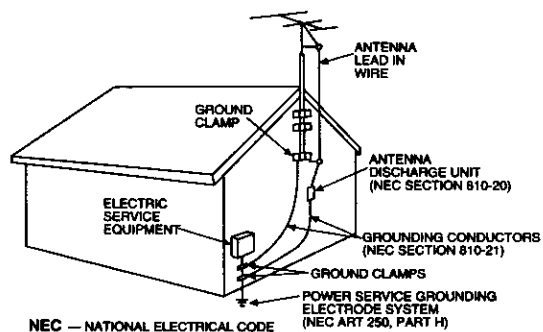

14. **Lightning** — For added protection of this video unit receiver during a lightning storm, or when it is left unattended and unused for long periods of time, unplug it from the wall outlet and disconnect the antenna or cable system. This will prevent damage to the video unit due to lightning and power-line surges.

Important Safeguards

15. **Power Lines** — An outside antenna system should not be located in the vicinity of overhead power lines or other electric light or power circuits, or where it can fall into such power lines or circuits. When installing an outside antenna system, extreme care should be taken to keep from touching such power lines or circuits as contact with them might be fatal.
16. **Overloading** — Do not overload wall outlets and extension cords as this can result in a risk of fire or electric shock.
17. **Objects and Liquids** — Never push objects of any kind into this video unit through openings as they may touch dangerous voltage points or short out parts that could result in a fire or electric shock. Never spill liquid of any kind onto the video unit.
18. **Servicing** — Do not attempt to service this video unit yourself as opening or removing covers may expose you to dangerous voltage or other hazards. Refer all servicing to qualified service personnel.
19. **Damage Requiring Service** — Unplug this video unit from the wall outlet and refer servicing to qualified service personnel under the following conditions:
 - a. When the power-supply cord or plug is damaged.
 - b. If any liquid has been spilled onto, or objects have fallen into the video unit.
 - c. If the video unit has been exposed to rain or water.
 - d. If the video unit does not operate normally by following the operating instructions. Adjust only those controls that are covered by the operating instructions, as an improper adjustment of other controls may result in damage and will often require extensive work by a qualified technician to restore the video unit to its normal operation.
 - e. If the video unit has been dropped or the cabinet has been damaged.
 - f. When the video unit exhibits a distinct change in performance — this indicates a need for service.
20. **Replacement Parts** — When replacement parts are required, be sure the service technician has used replacement parts specified by the manufacturer or have the same characteristics as the original part. Unauthorized substitutions may result in fire, electric shock or other hazards.
21. **Safety Check** — Upon completion of any service or repairs to this video unit, ask the service technician to perform safety checks to determine that the video unit is in safe operating order.

Precautions

USE & LOCATION

- **TO AVOID SHOCK HAZARD ...** Your Camcorder and power supply should not be exposed to rain or moisture. Do not connect the power supply or operate your Camcorder if it gets wet. Your Camcorder has been designed for outdoor use, however it is not designed to sustain direct exposure to water, rain, sleet, snow, sand, dust, or a direct splashing from a pool or even a cup of coffee. This action could permanently damage the internal parts of your Camcorder. Do not attempt to disassemble this unit. There are no user serviceable parts inside. Unplug your Camcorder from the power supply before cleaning.
- **DO NOT AIM YOUR CAMCORDER AT THE SUN OR OTHER BRIGHT OBJECTS.**
- **DO NOT LEAVE THE CAMCORDER WITH THE EVF AIMED DIRECTLY AT THE SUN AS THIS MAY CAUSE DAMAGE TO THE INTERNAL PARTS OF THE EVF.**
- **DO NOT EXPOSE YOUR CAMCORDER TO EXTENDED HIGH TEMPERATURE ...** Such as, in direct sunlight, inside a closed car, next to a heater, etc... This action could permanently damage the internal parts of your Camcorder.
- **AVOID SUDDEN CHANGES IN TEMPERATURE ...** If the unit is suddenly moved from a cold place to a warm place, moisture may form on the tape and inside the unit.
- **DO NOT LEAVE YOUR CAMCORDER OR THE POWER SUPPLY TURNED ON WHEN NOT IN USE.**
- **STORAGE OF YOUR CAMCORDER ...** Store and handle your Camcorder in a manner that will not subject it to unnecessary movement (avoid shaking and striking). Your Camcorder contains a sensitive pick-up device which could be damaged by improper handling or storage.

CARE

- **TO CLEAN YOUR CAMCORDER ...** Do not use strong or abrasive detergents when cleaning your Camcorder body.
- **TO PROTECT THE LENS ...** Do not touch the surface of the lens with your hand. Use a commercial camcorder lens solution and lens paper when cleaning the lens. Improper cleaning can scratch the lens coating.
- **TO PROTECT THE FINISH OF YOUR CAMCORDER ...** Before handling your Camcorder, make sure your hands and face are free from any chemical products, such as suntan lotion, as it may damage the finish.

Table of Contents

Getting Started	
Things You Should Know	2
Important Safeguards	4
Precautions	5
Self Demo Mode	7
Quick Operation Guide	8
Supplying Power	11
Cassette Information	14
Attaching Shoulder Strap	15
MENU Mode	16
Setting the Clock	18
Built-in Auto Light	21
Basic Operation	
Camera Recording	22
Playing Back Recordings	27
Copying your Tapes (dubbing)	32
Special Features	
Four-Speed Power Zoom	33
Backlight	33
Focus	34
High Speed Shutter	35
Tally Lamp	36
Auto Fade	37
Color Digital Fade	38
Color Digital Filter	40
Digital Zoom	41
Digital Electronic Image Stabilization (E.I.S.)	42
Still/Strobe/Wide	43
Security Mode	44
Time Lapse	46
Message Mode	47
Intelligent Titler	48
Digital Still Camera	51
CompactFlash Card Insertion/Removal	51
Recording	52
Using the Light	54
Playback	55
Deleting Specific Image Pages	56
Deleting All Image Pages	57
Picture in Picture Wipe Title	58
Digital Wipe Mode	59
PhotoShot Title Library	60
PC Connection	61
Using a PCMCIA Adaptor (optional)	67
For Your Information	
Viewfinder/LCD Monitor Indications	68
Operation Notes	73
Replacing Clock Battery	74
Palmcorder Accessory System	75
Palmcorder Accessory Order Form	77
Specifications	78
Before Requesting Service	79
Request for Service Notice	81
Warranty	82
Index	84
Spanish Quick Use Guide/Guía Para Uso Rápido	86

Self Demo Mode

Self Demo mode is on when the screen below appears. Follow the steps below to turn it off.

Before you begin...

- Connect Camcorder to power source.

EVF Screen

Panasonic

ITS TAPES PLAY
IN YOUR VCR
YES, IT'S VHS!
26x LENS / 300x D. ZOOM
DIGITAL STABILIZATION
DEDICATED 5-HEAD
DIGITAL PHOTOSHOT

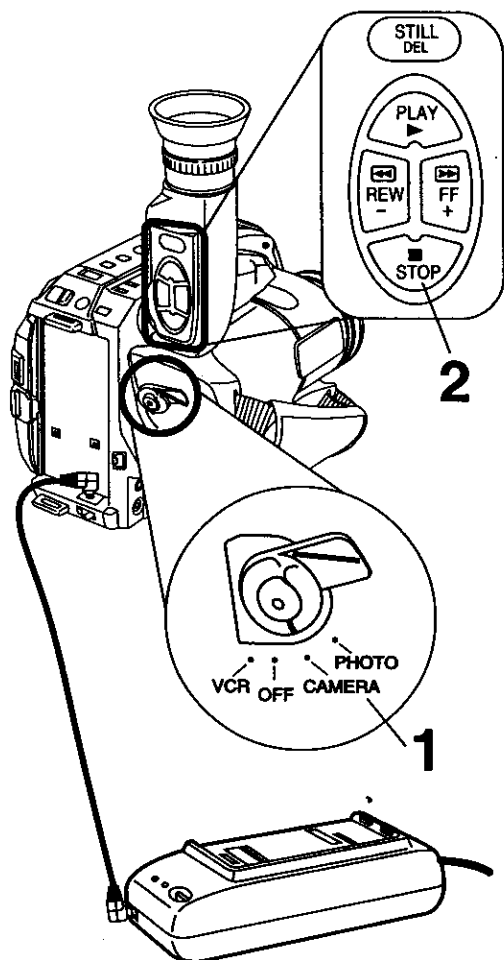

1 Set **POWER** to **CAMERA**.

2 Hold down **STOP** over 5 seconds.

Note:

- Self Demo stops automatically if battery is attached (page 11) and cassette tape is inserted (page 14).
- Inserting a tape alone (or attaching a partially charged battery) only temporarily stops Self Demo.
- Self Demo stops for 30 seconds when a function key other than Power, Tape Speed Selector, and Light is pressed.

To turn Self Demo back on.

- With **DISPLAY** held down, slide **POWER** to **CAMERA** and wait for Self Demo to begin.

Quick Operation Guide

Charge the Battery Pack

Charge Battery Pack fully before operation (page 11).

2

Insert Battery.
CHARGE Lamp lights and then goes out when charging is done.

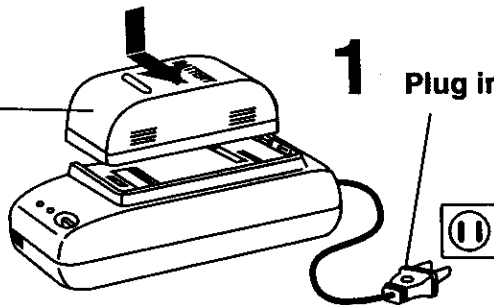

1

Plug in AC Adaptor.

Insert the CompactFlash Card

When the CompactFlash Card is not inserted in CAMERA or PHOTO mode, "NO CF CARD" appears on-screen. Be sure to insert the CompactFlash Card before using the Built-in Digital Still Camera (page 51). CAMERA recording is possible even when the CompactFlash Card is not inserted.

2

Slide TAPE EJECT to open door.

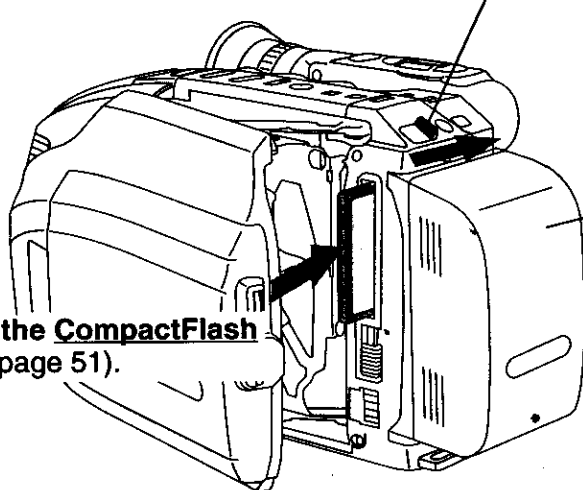

1

Attach fully charged Battery
(page 11).

3

Insert the CompactFlash Card
(page 51).

Quick Operation Guide

Insert Cassette

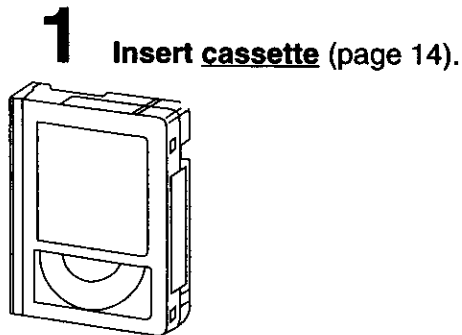
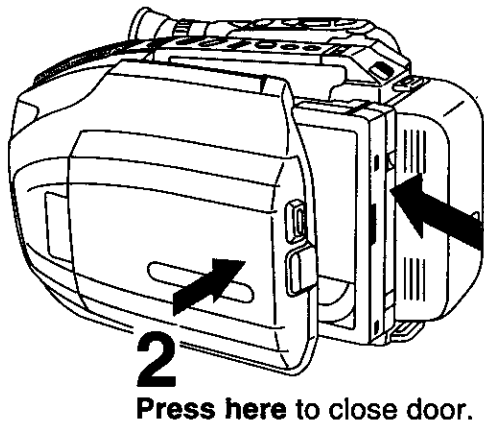

Camera Recording

When the LCD monitor is fully open, the Viewfinder automatically turns OFF (page 23).

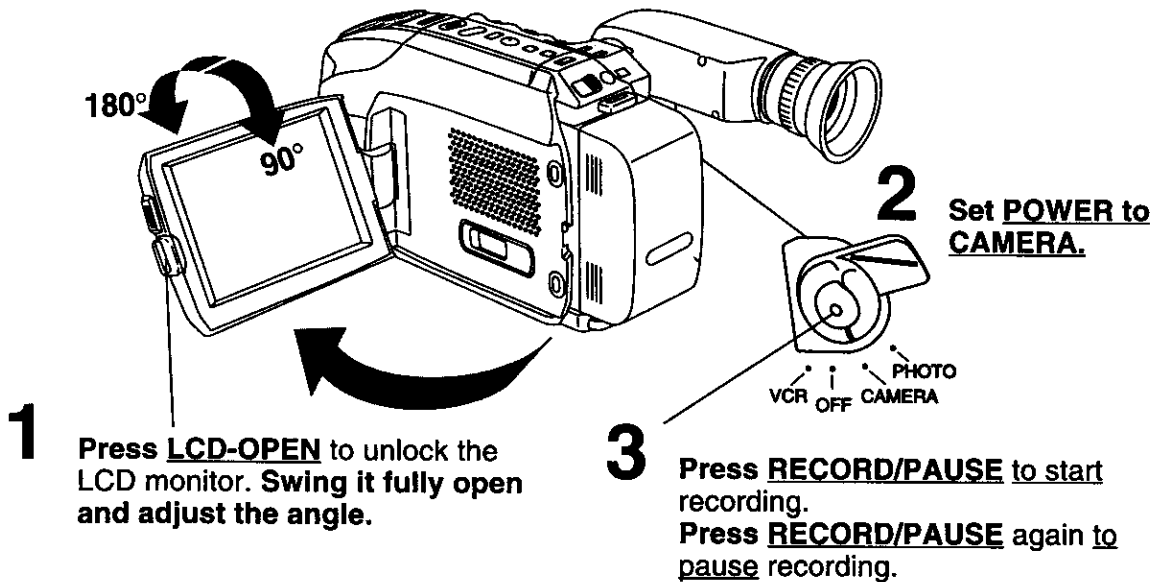

Quick Operation Guide

Playback using the LCD Monitor

When the LCD monitor is fully open, the Viewfinder automatically turns OFF (page 27).

Before you begin...

- Charge Battery Pack fully before operation (page 11).

- 1** Press **LCD-OPEN** to unlock the LCD monitor. Swing it fully open and adjust the angle.

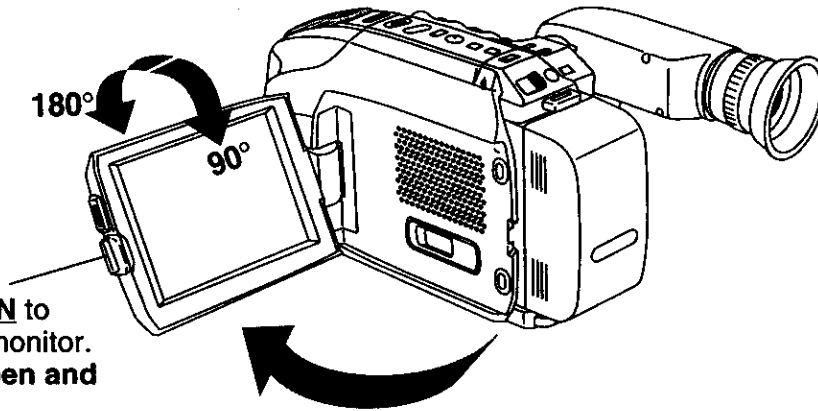

- 2** Set **POWER** to **VCR**.

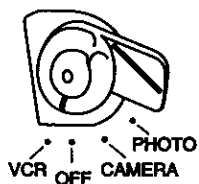

- 3** Press **REWIND/SEARCH** to rewind tape.

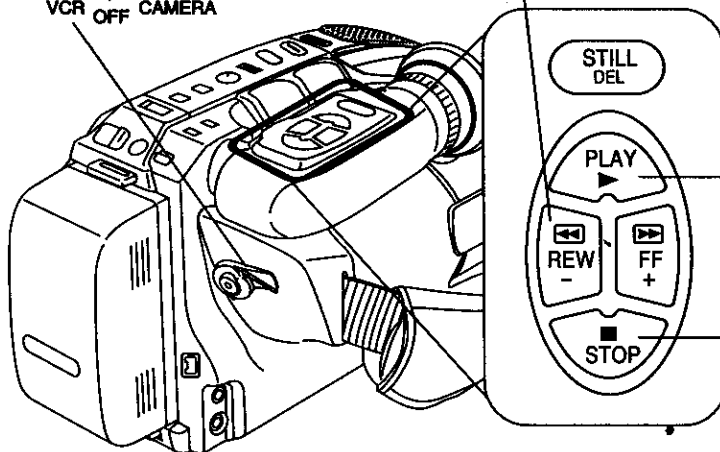

- 4** Press **PLAY** to start playback.

- 5** Press **STOP** to stop playback.

Supplying Power

Charge the Battery Pack

Charge Battery Pack fully before use.

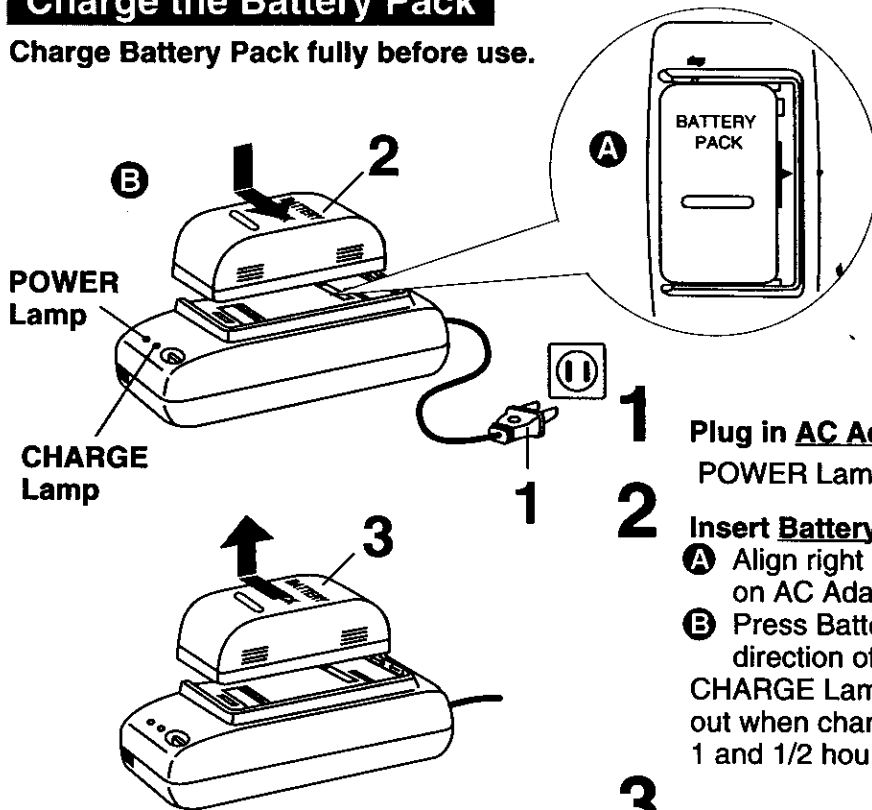

- 1 Plug in AC Adaptor.**
POWER Lamp lights.
- 2 Insert Battery.**
A Align right side of Battery with line on AC Adaptor.
B Press Battery down and slide in direction of arrow.
CHARGE Lamp lights and then goes out when charging is done (approx. 1 and 1/2 hours).
- 3 Remove Battery**
Slide Battery out and off.

Note:
After recharging 5 times, use BATTERY REFRESH feature as explained on page 12.

- Battery life gradually decreases after repeated use and recharging. If operation time becomes very short, even after a sufficient charge, discard Battery properly (page 12).

Use the Battery Pack

A fully charged Battery provides a maximum of about 2 hours of continuous use (LCD monitor off) or about 1.5 hours (LCD monitor on). Actual time may vary due to operating conditions. Using the Built-in Light decreases operating time.

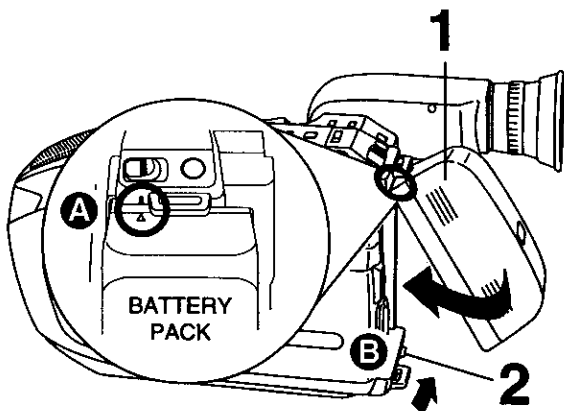

- 1 Attach Battery**
A Align Battery with top of mounting surface.
B Press and snap into place.
- 2 Remove Battery**
While sliding **BATTERY RELEASE**, remove Battery.

Supplying Power

Battery Refresh

This feature completely discharges Battery before recharging begins. Use after about every 5 charges for optimum Battery performance.

CHARGE Lamp

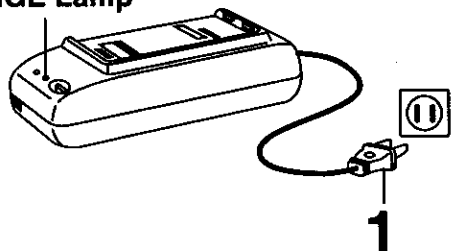

1

1 Plug in AC Adaptor.

- POWER Lamp stays on as long as Adaptor is plugged in.

2

2 Place Battery into Adaptor.

3

3 Press BATTERY REFRESH.

The CHARGE Lamp flashes during discharge then stays lit until charging is complete.

If BATTERY REFRESH is pressed by mistake, remove Battery from Adaptor and reinsert it for normal charging.

4

4 Remove Battery.

- Charging takes about 7 and 1/2 hours when Battery Refresh is used.
- Battery will not operate in extremely high temperatures.

3

BATTERY REFRESH

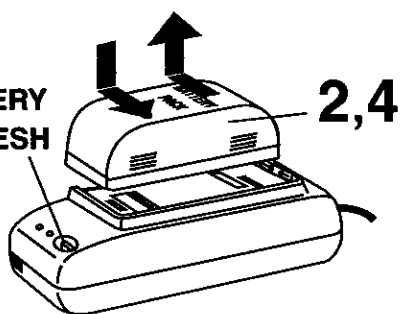

Battery Care

Caution:

- Charge only with specified charger.
- Battery can be charged within a temperature range of 50° F (10° C) and 95° F (35° C).
- Battery is normally warm after charging or just after use.
- Do not use an insufficiently charged or worn-out Battery.

Safety precautions:

- Do not get Battery near, or dispose of in fire.
- Do not directly connect (short circuit) the positive (+) and negative (-) terminals.
- Never attempt to disassemble or reassemble Battery.

To avoid Battery damage:

- Do not drop or jar Battery.
- Use Battery with specified units only.
- If Battery is used in extremely high temperatures, a safety device will automatically prevent operation.

To prolong Battery life:

- While not in use, remove Battery from the Camcorder and AC Adaptor and store in a cool, dark, dry place.
- Keep Battery terminals clean.

U.S.A. CONSUMERS:

ATTENTION:

The product you have purchased is powered by a nickel cadmium battery which is recyclable. At the end of its useful life, under various state and local laws, it is illegal to dispose of this battery into your municipal waste stream. Please call 1-800-8-BATTERY for information on how to recycle this battery.



Supplying Power

AC Adaptor

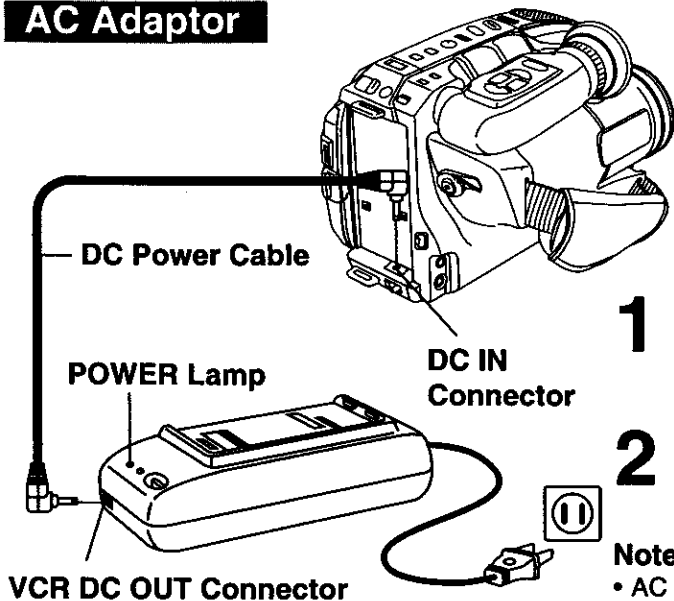

1 Connect **AC Adaptor VCR DC OUT** to **Camcorder DC IN** with supplied DC Power Cable.

2 Plug in AC Adaptor. POWER Lamp lights.

Notes:

- AC Adaptor cannot power Camcorder while charging Battery.
- When not in use, unplug AC Adaptor from AC outlet. (Adaptor uses 1.2 W of electricity while plugged in.)

CAUTION:

This unit will operate on 110/120/220/240V AC. An AC plug adaptor may be required for voltages other than 120V AC. Please contact either a local or foreign electrical parts distributor for assistance in selecting an alternate AC plug. We recommend using the accessory power plug adaptor (VJSS0070) in an area which has special AC outlets.

Car Battery Cord (Optional)

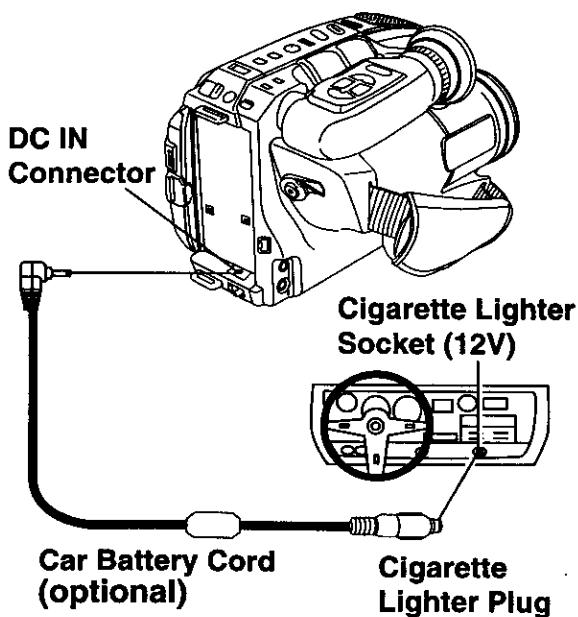

1 Connect **PV-C16 Car Battery Cord** (optional, page 76) to **Camcorder DC IN**.

2 **A** Start engine first.
B Plug Car Battery Cord into Cigarette lighter socket.

- If Car Battery cord fuse needs replacing, use exact current rating (in amps).

Notes:

- This cord only works in vehicles equipped with **DC 12V (negative ground)** battery. Check with your car/truck dealer. Use only specified car battery cord.
- To avoid blowing the car battery cord fuse, do step 2 in the proper order.
- Running vehicles must be well ventilated.
- When not in use, disconnect cigarette lighter plug.

Cassette Information

Cassette Insertion/Removal

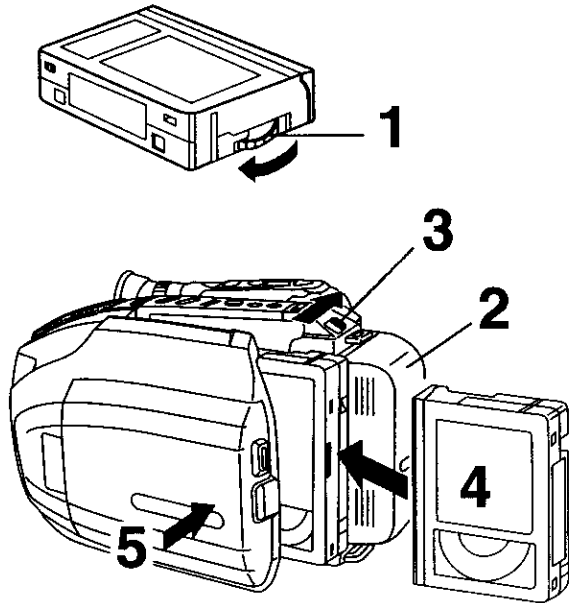

- 1** Turn **Tape Wheel** in direction of arrow until there is no slack.
 - 2** Attach **Battery** (page 11).
 - 3** Slide **TAPE EJECT** to open door.
 - 4** Insert **cassette** as shown.
 - 5** Press here to close door.
- To remove the cassette, slide the **TAPE EJECT** switch.

Record/Playback Time

Use tapes with the **VHS-C** mark in this unit.

TAPE SPEED Selector

Tape Speed Selector Position	Cassette type		
	TC-20	TC-30	TC-40
SP (Standard Play)	20 minutes	30 minutes	40 minutes
SLP (Super Long Play)	1 hour	1 hour 30 minutes	2 hours

• SLP playback may contain more picture noise.

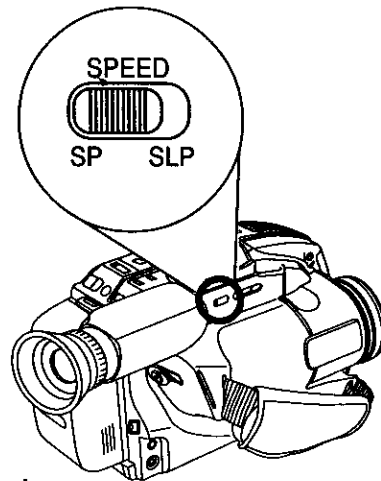

Erase Protection Tab

A record tab ensures recordings are not accidentally erased.

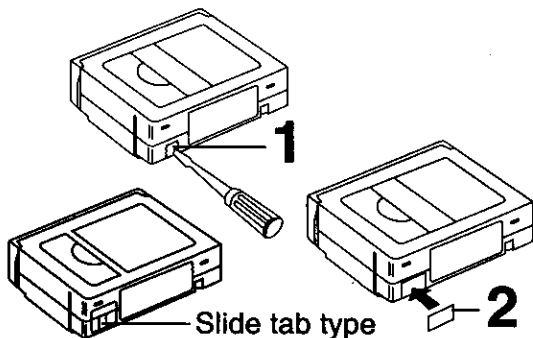

- 1** To prevent erasure, **break off tab** with screwdriver. (Or, slide tab open.)
- 2** To record again, **cover hole** with adhesive tape. (Or, slide tab closed.)

Attaching Shoulder Strap

Remove Battery Pack before doing steps.

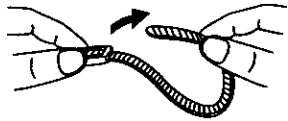

1 Undo strap ends from buckles.

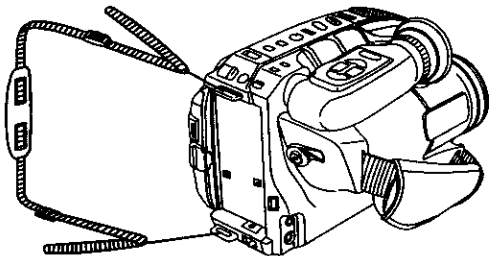

2 Thread strap ends through Strap Rings on Camcorder.

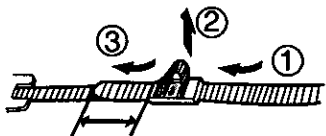

min. 1 inch (25.4mm)

3 Re-insert the strap ends into buckles.

Adjusting the Length

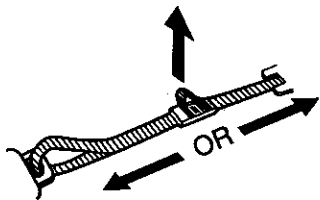

1 Pull a loop of strap from buckle.

2 Pull strap tight to shorten or lengthen.

Hand Strap

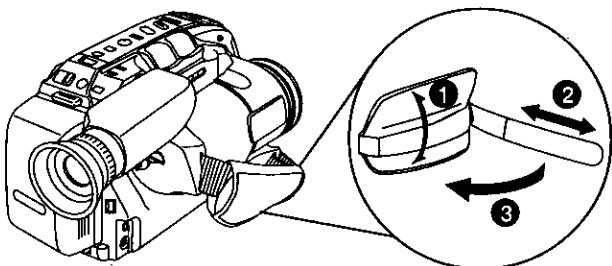

Adjust Hand Strap length to fit your hand as shown.

MENU Mode

Using MENU Mode

Before you begin...

- Connect Camcorder to power source.
- Set POWER to CAMERA.

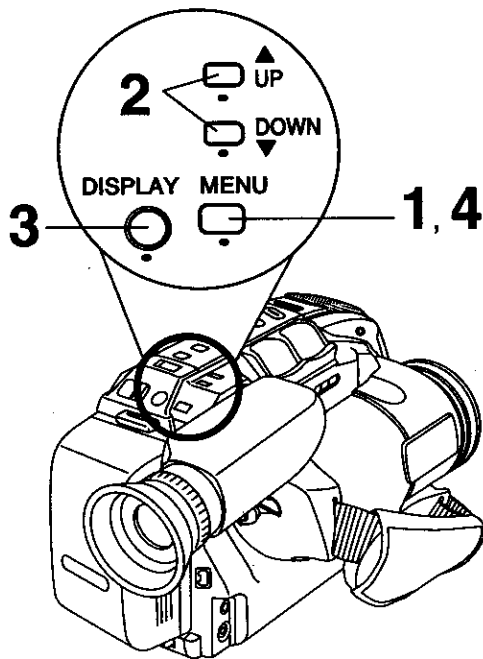

1 Press **MENU** for MENU mode.

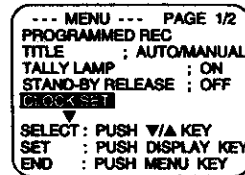

2 Press **UP** \blacktriangle or **DOWN** \blacktriangledown to highlight menu item.

3 Press **DISPLAY** to set selection.

4 Press **MENU** to exit.

Note:

- The Menu mode is canceled if UP/DOWN($\blacktriangle/\blacktriangledown$), DISPLAY, or MENU are not pressed within 5 minutes.

MENU Mode

MENU Mode Screen

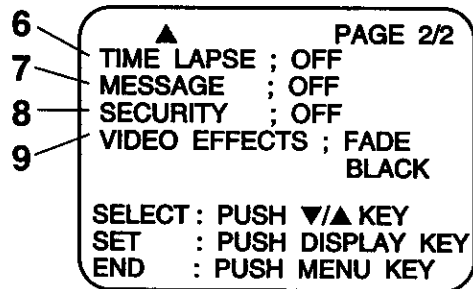
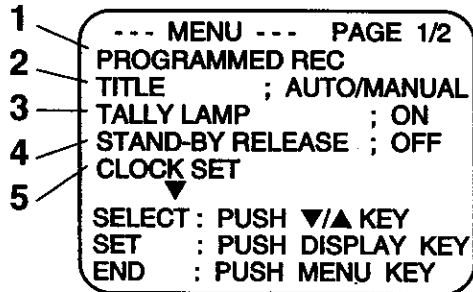

- 1 **PROGRAMMED REC** (page 26).
Camcorder starts and stops recording at a preset time.
- 2 **TITLE** (pages 48~50).
AUTO/MANUAL : 16 items
PHRASE : 10 items
- 3 **TALLY LAMP** (page 36).
ON: lamp lights during recording.
- 4 **STAND-BY RELEASE** (page 24).
ON: enables quick resumption of recording from Stand-by mode.
- 5 **CLOCK SET** (pages 18~20).
Select to set clock.
- 6 **TIME LAPSE** (page 46).
ON: enables TIME LAPSE recording.
- 7 **MESSAGE** (page 47).
ON: enables MESSAGE recording.
- 8 **SECURITY** (pages 44, 45).
MOTION : enables Motion Security recording.
AUDIO : enables Audio Security recording.
MOTION•AUDIO: enables Motion•Audio Security recording.
- 9 **VIDEO EFFECTS** (pages 37~40).
AUTO FADE : BLACK or WHITE
DIGITAL FADE : TYPE → 7 types
COLOR → 8 colors
DIGITAL FILTER : COLOR → 5 colors

Setting the Clock

Set the following items in order: Time Zone, Daylight Saving Time, Date and Time.

Setting the Time Zone

The Camcorder is preset to Eastern time. To change time zone, do steps at right.

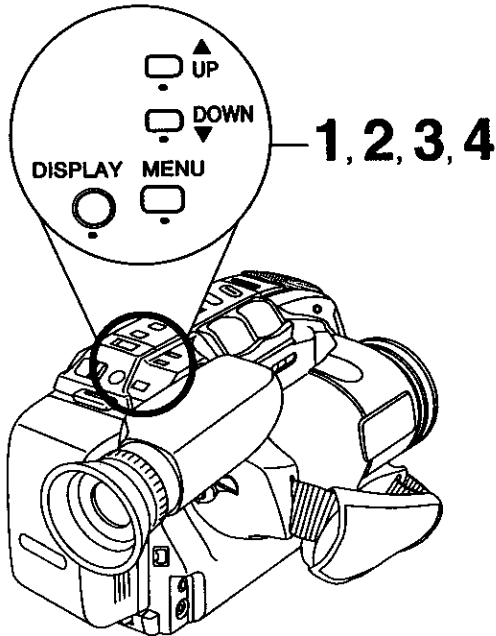

Before you begin...

- Connect Camcorder to power source.
- Set POWER to CAMERA.

Note:

- Setting POWER to VCR also displays CLOCK SET menu.
- Clock may lose or gain up to 2 minutes per month. To adjust, see page 20.

- 1 Press **MENU** for MENU mode. Press **UP ▲** or **DOWN ▼** to select **CLOCK SET**.

```

--- MENU --- PAGE 1/2
PROGRAMMED REC
TITLE      : AUTOMANUAL
TALLY LAMP : ON
STAND-BY RELEASE : OFF
CLOCK SET
↓
SELECT : PUSH ▼/▲ KEY
SET    : PUSH DISPLAY KEY
END    : PUSH MENU KEY
    
```

- 2 Press **DISPLAY** for CLOCK SET menu. Press **UP ▲** or **DOWN ▼** to select **TIME ZONE**.

```

--- CLOCK SET ---
TIME ZONE : EASTERN
D. S. T.   : AUTO
DATE/TIME  : 12:00:00AM
            JAN 1 1999
↓
SELECT : PUSH ▼/▲ KEY
SET    : PUSH DISPLAY KEY
END    : PUSH MENU KEY
    
```

- 3 Press **DISPLAY** for SELECT TIME ZONE menu. Press **UP ▲** or **DOWN ▼** to select local time zone.

```

--- SELECT TIME ZONE ---
ATLANTIC      PACIFIC
EASTERN    ALASKA
CENTRAL      HAWAII
MOUNTAIN     SAMOA
↓
SELECT : PUSH ▼/▲ KEY
SET    : PUSH DISPLAY KEY
    
```

- 4 Press **DISPLAY** to confirm entry. Press **MENU** twice to exit.

- When traveling, repeat these steps and select one of the 8 listed time zones to set the clock to local time.

Time Zone chart

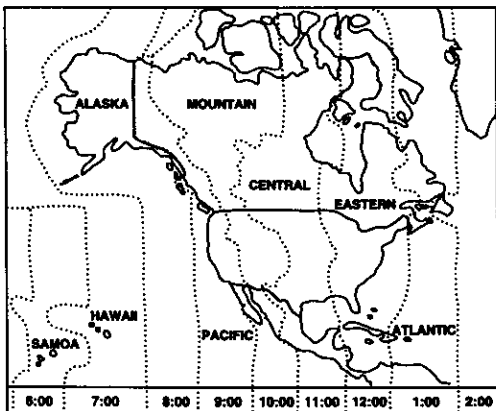

Note:

When traveling outside the listed time zones, set clock to local time manually (page 20).

Setting the Clock

Auto Daylight Saving Time

Clock will auto-adjust to daylight-saving time (DST).

The Camcorder is preset to DST: **AUTO**. If DST is not observed in your area, set to **OFF** by doing the following steps.

Before you begin...

- Connect Camcorder to power source.
- Set POWER to CAMERA.

Note:

- When POWER is set to VCR, CLOCK SET menu appears.*
- Auto DST does not function if time zone is set to Hawaii or Samoa (page 18).

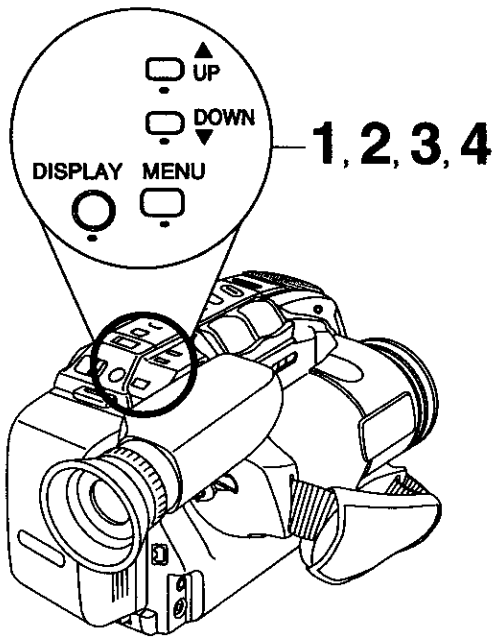

- 1 Press **MENU** for MENU mode. Press **UP ▲** or **DOWN ▼** to select **CLOCK SET**.

```

--- MENU --- PAGE 1/2
PROGRAMMED REC
TITLE : AUTO/MANUAL
TALLY LAMP : ON
STAND-BY RELEASE : OFF
CLOCK SET
↓
SELECT : PUSH ▼/▲ KEY
SET : PUSH DISPLAY KEY
END : PUSH MENU KEY
    
```

- 2 Press **DISPLAY** for CLOCK SET menu. Press **UP ▲** or **DOWN ▼** to select **D.S.T.**

```

--- CLOCK SET ---
TIME ZONE : EASTERN
D.S.T. : AUTO
DATE / TIME : 12 : 00 : 00AM
                JAN 1 1999
↓
SELECT : PUSH ▼/▲ KEY
SET : PUSH DISPLAY KEY
END : PUSH MENU KEY
    
```

- 3 Press **DISPLAY** for DAYLIGHT SAVING TIME menu. Press **UP ▲** or **DOWN ▼** to select OFF or AUTO.

```

-- DAYLIGHT SAVING TIME --
↓
AUTO
OFF
↓
SELECT : PUSH ▼/▲ KEY
SET : PUSH DISPLAY KEY
    
```

- 4 Press **DISPLAY** to confirm entry. Press **MENU** twice to exit.

Spring (First Sunday in April):

DST: AUTO = ahead one hour.

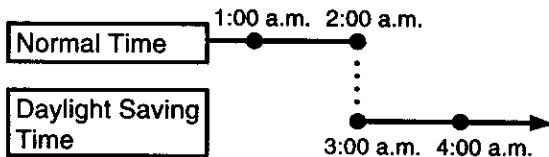

Autumn (Last Sunday in October):

DST: AUTO = back one hour.

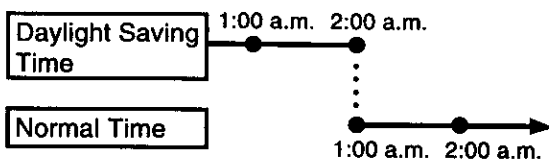

Setting the Clock

Setting Date and Time

Date and time including leap year are calculated up to DEC 31, 2097.

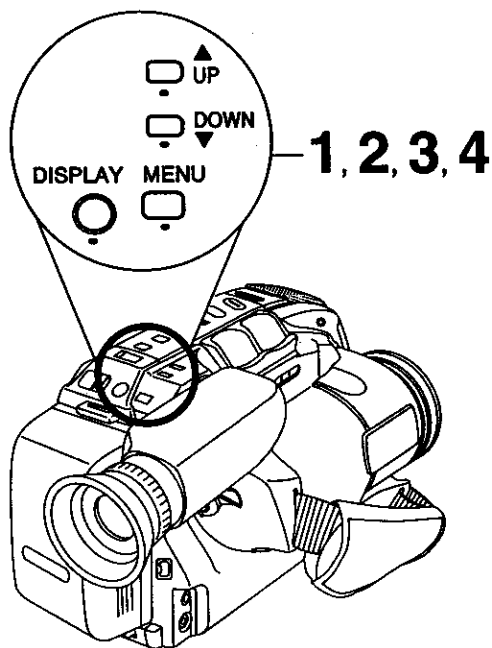

Before you begin...

- Connect Camcorder to power source.
- Set POWER to CAMERA.

Note:

- When POWER is set to VCR, CLOCK SET menu appears.

- 1 Press **MENU** for MENU mode. Press **UP ▲** or **DOWN ▼** to select **CLOCK SET**.

```

--- MENU --- PAGE 1/2
PROGRAMMED REC
TITLE      : AUTOMANUAL
TALLY LAMP : ON
STAND-BY RELEASE : OFF
CLOCK SET
SELECT: PUSH ▼/▲ KEY
SET    : PUSH DISPLAY KEY
END    : PUSH MENU KEY
    
```

- 2 Press **DISPLAY** for CLOCK SET menu. Press **UP ▲** or **DOWN ▼** to select **DATE/TIME**.

```

--- CLOCK SET ---
TIME ZONE : EASTERN
D. S. T.  : AUTO
DATE/TIME: 12:00:00AM
              JAN 1 1999
SELECT: PUSH ▼/▲ KEY
SET    : PUSH DISPLAY KEY
END    : PUSH MENU KEY
    
```

- 3 Press **DISPLAY** for DATE/TIME menu.

```

--- DATE/TIME SETTING ---
-12:00:00AM-
  JAN 1 1999
SELECT: PUSH ▼/▲ KEY
SET    : PUSH DISPLAY KEY
    
```

- 4 Press or hold down **UP ▲** or **DOWN ▼** to select hour, then press **DISPLAY** to fix.

Repeat for minute, month, day, and year. Clock starts when year is entered.

Press **MENU** twice to exit.

EXAMPLE

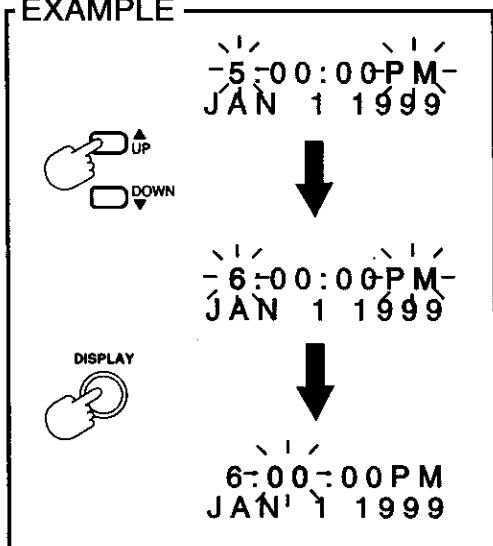

Built-in Auto Light

Using the Light

For recording in dim lighting.

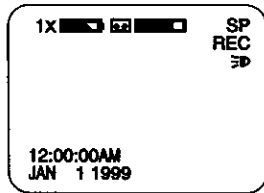
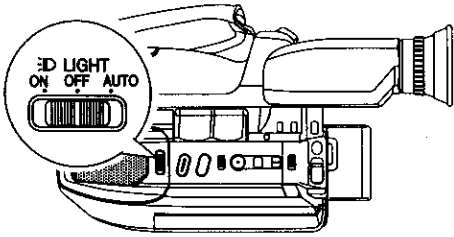

Before you begin...

- Connect Camcorder to power source.
- Set POWER to CAMERA.

Set LIGHT to AUTO.

Light turns on/off automatically according to lighting conditions.

Or, set LIGHT to ON/OFF manually.

\Rightarrow D appears in EVF when Light is on.

Caution:

Light becomes hot. Never cover Light while on.

Replacing the Bulb

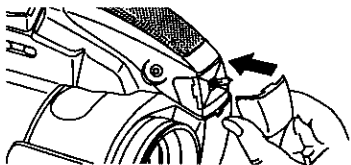
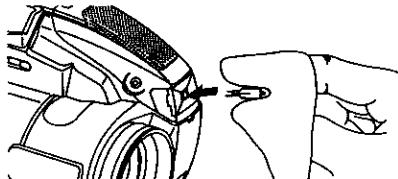
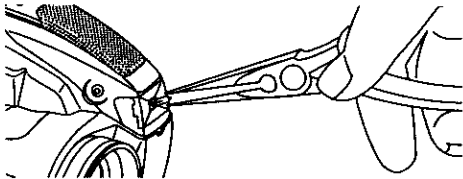
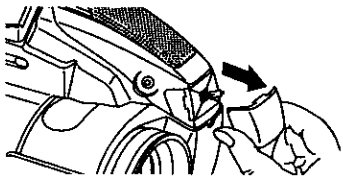

Before you begin...

- Order Part No. VULS0001 (VLLW0015 and cushions) for replacement bulb unit.
- Set POWER to OFF.

1 Press in on both sides of lens cover and pull straight out and off.

2 Using Tweezers or needle-nose pliers, carefully remove bulb.
• Take unit to service center if you need assistance.

3 Replace bulb using a clean cloth or tissue.

4 Replace lens cover.

DANGER:

Use only replacement bulb (PART NO. VLLW0015) supplied by Panasonic to reduce risk of fire.

Handle new bulb with cloth or tissue as skin oils will decrease bulb life.

Remove lens cover and allow bulb to cool before replacing to avoid possible burn hazard.

Note:

- Using Light reduces battery operating time.
- Provide proper ventilation when using Light extensively in a hot environment.
- Using Light when the Camcorder is powered by a car battery may shorten bulb life.
- Set Light to OFF when not in use.
- Handle bulb gently. Excessive force may cause bulb to crack.

Camera Recording

Simple Recording

Before you begin...

- Connect Camcorder to power source.
- Insert cassette with record tab (page 14).

1 Set **POWER** to **CAMERA**.

Lens Cover opens.

EVF

- Be sure **POWER** is fully turned to **CAMERA** position

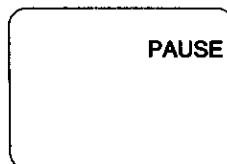

Record/Pause mode.

2 Look into Viewfinder and adjust Vision Adjustment control to your eyesight.

3 Slide **TAPE SPEED** to SP or SLP (page 14).

4 Press **RECORD/PAUSE** to start or pause recording. REC lamp lights during recording. Tally lamp also lights if set to ON (page 36).



5 Set **Power** to **OFF** when finished.

- **To remove cassette**, slide **TAPE EJECT** in Record/ Pause mode. (page 14).

Note:

- When Camcorder is aimed at excessively bright objects, or bright lights, a vertical bar may appear in the picture. This is normal for the CCD pick-up. Try to avoid this when possible.

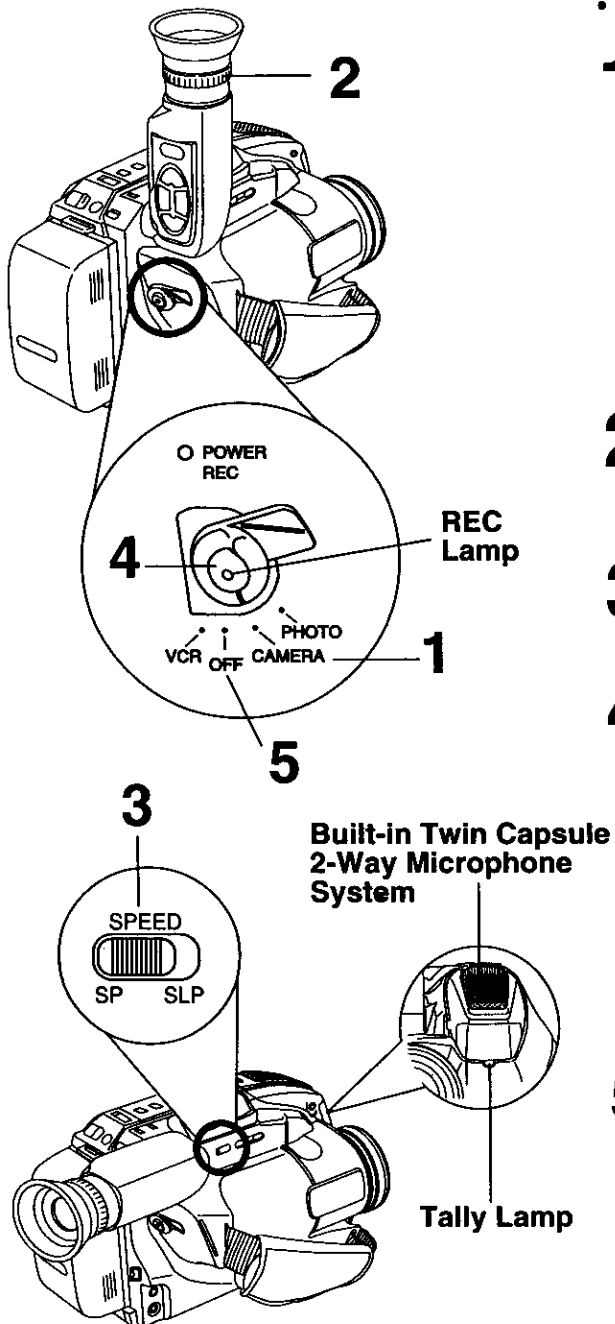

Camera Recording

Using the LCD Monitor

View recording scene on the LCD (Liquid Crystal Display).

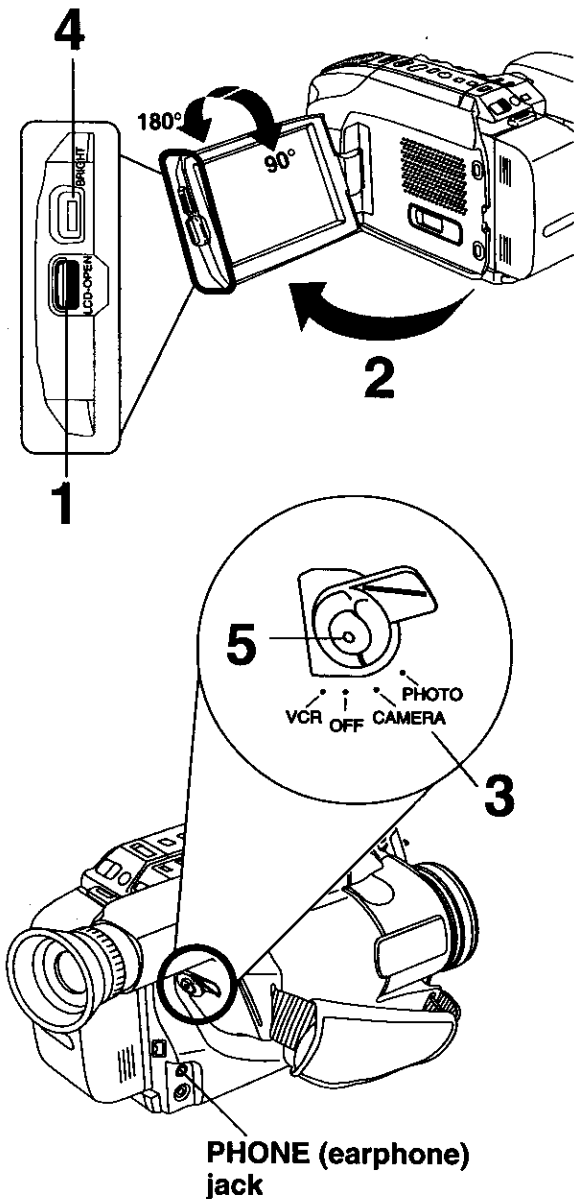

Before you begin...

- Connect Camcorder to power source.
- Insert cassette with record tab (page 14).

1 Press **LCD-OPEN** to unlock LCD.

2 Swing **LCD fully open** and adjust viewing angle.

Caution:

Rotating partially open LCD monitor may block cassette door and damage Camcorder body.

3 Set **POWER to CAMERA**.

- LCD monitor turns off/on by the POWER switch.
- Viewfinder shuts off when LCD is fully opened and turns back on when LCD is closed completely.
- Both Viewfinder and LCD monitor turn on when LCD is at 180° (see above left).
This allows both you and the subject to view the recording.

4 Turn **BRIGHT control** to adjust LCD brightness level.

5 Press **RECORD/PAUSE** to start recording (page 22).

Note:

- Using LCD reduces battery operation time.
- To hear sound while recording, connect earphone (M3 type: not supplied) to PHONE jack. Earphone volume cannot be changed while in CAMERA mode.
- Lock LCD closed when not in use.

Camera Recording

Stand-by Quick Release

If left in RECORD/PAUSE mode for 5 minutes, Camcorder switches to Stand-by mode to conserve battery. When set to ON, Stand-by Quick Release lets you resume recording by pressing RECORD/PAUSE two times. New camcorders will default to OFF.

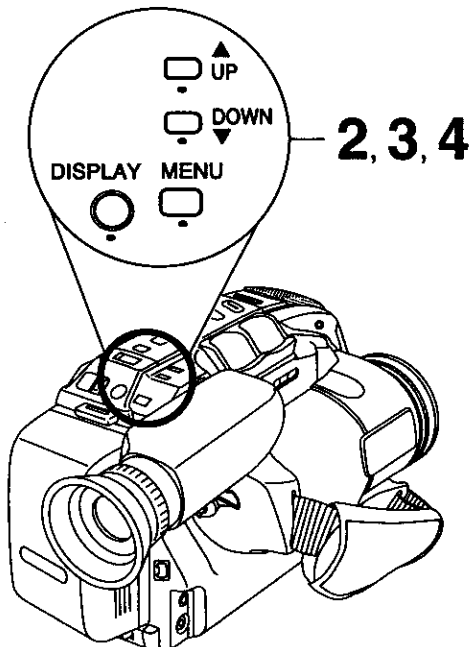
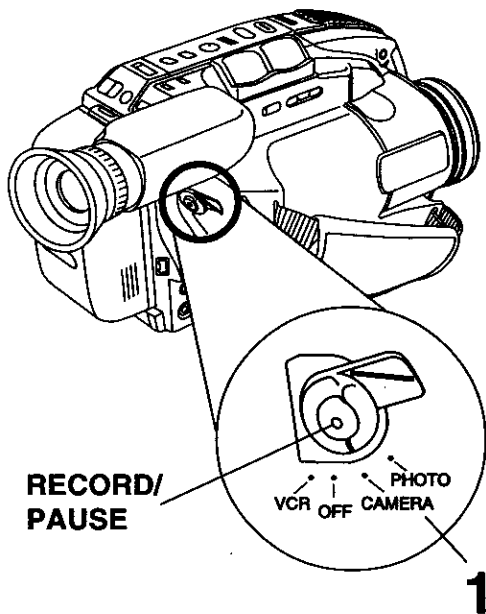

Before you begin...

- Connect Camcorder to power source.
- Insert cassette with record tab (page 14).

- 1** Set POWER to CAMERA.
- 2** Press MENU for MENU mode.
Press UP ▲ or DOWN ▼ to select STAND-BY RELEASE.

```
--- MENU --- PAGE 1/2
PROGRAMMED REC
TITLE          ; AUTO/MANUAL
TALLY LAMP    ; ON
STAND-BY RELEASE ; ON
CLOCK SET
↓
SELECT : PUSH ▼/▲ KEY
SET     : PUSH DISPLAY KEY
END     : PUSH MENU KEY
```

- 3** Press DISPLAY to select ON/OFF.
ON: From Stand-by mode,
press RECORD/PAUSE two times
to resume recording.
OFF: From Stand-by mode,
set POWER to OFF, then to
CAMERA.
Press RECORD/PAUSE to record.

- 4** Press MENU to exit.

Camera Recording

Easy Edit Stand-by

For a smooth transition between scenes if recording is stopped, and then started within 24 hours.

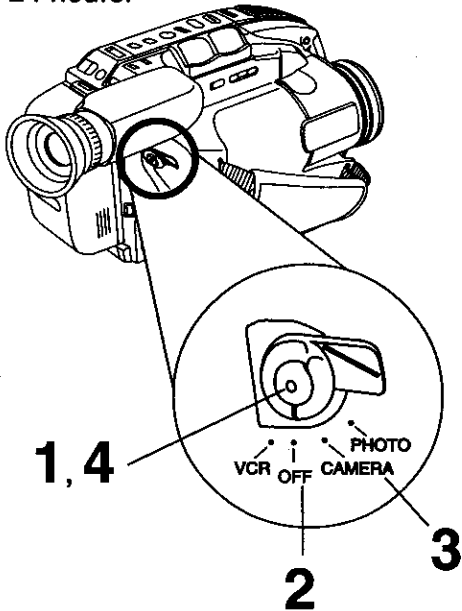

Before you begin...

- Connect Camcorder to power source.
- Insert cassette with record tab (page 14).

- 1** Press **RECORD/PAUSE** to stop recording.
- 2** Set **POWER** to **OFF** and leave cassette in Camcorder.
- 3** To resume recording, set **POWER** to **CAMERA**.
- 4** Press **RECORD/PAUSE** to resume recording.

Note:

- Use Manual Easy Edit (below) if more than 24 hours before recording is resumed.

Manual Easy Editing

For proper continuity when taping from Stop mode or after attaching a new Battery.

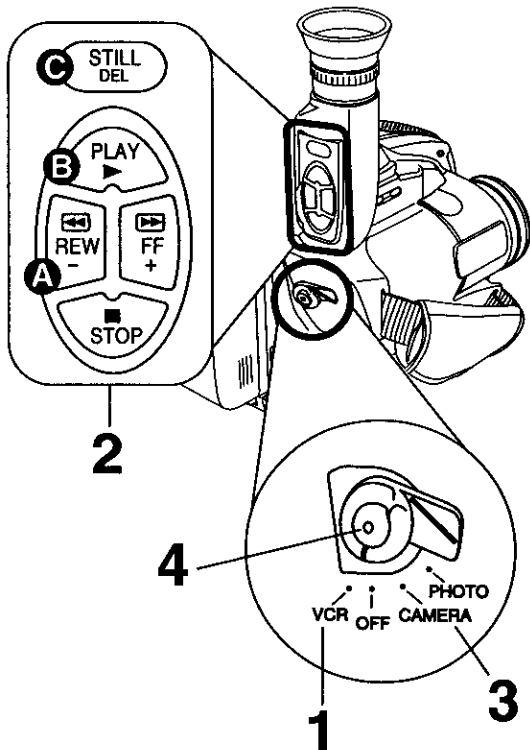

Before you begin...

- Connect Camcorder to power source.
- Insert cassette with record tab (page 14).

- 1** Set **POWER** to **VCR**.
- 2** **A** Press **REWIND/SEARCH** to rewind a few seconds of tape.
B Press **PLAY** to review recording.
C Press **STILL** where you want to continue recording.
- 3** Set **POWER** to **CAMERA**.
- 4** Press **RECORD/PAUSE** to resume recording.

Camera Recording

Programmed Recording

Set a recording start and stop time. Or, set a 5 or 10 second interval recording to be done each minute.

Before you begin...

- Connect Camcorder to power source.
Use AC Adaptor for longer recordings.
- Insert cassette with record tab (page 14).
- Set POWER to CAMERA.

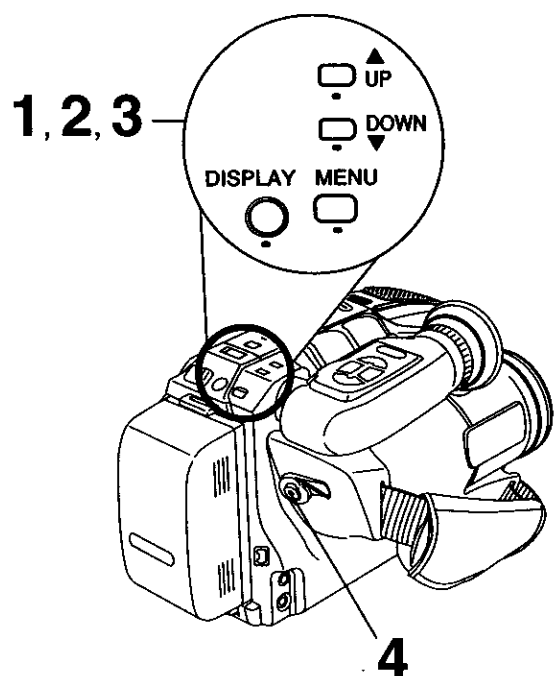

1 Press **MENU** for MENU mode. Press **UP ▲** or **DOWN ▼** to select **PROGRAMMED REC.**

```

--- MENU --- PAGE 1/2
PROGRAMMED REC
TITLE : AUTO/MANUAL
TALLY LAMP : ON
STAND-BY RELEASE : OFF
CLOCK SET
SELECT : PUSH ▼/▲ KEY
SET : PUSH DISPLAY KEY
END : PUSH MENU KEY
    
```

2 Press **DISPLAY**. (Current time is displayed.) Each additional press of **DISPLAY** increases start time by 30 minutes.

```

START : 10:20PM
REC TIME : 10MIN.
SELECT : PUSH ▼/▲ KEY
SET : PUSH DISPLAY KEY
START : PUSH RECORD KEY
CANCEL : PUSH MENU KEY
10:20:00PM
    
```

3 Press **DOWN ▼** to select **REC TIME**. Press **DISPLAY** repeatedly to select one of the options shown at the left.

```

START : 10:30PM
REC TIME : 10MIN.
SELECT : PUSH ▼/▲ KEY
SET : PUSH DISPLAY KEY
START : PUSH RECORD KEY
CANCEL : PUSH MENU KEY
10:20:00PM
    
```

To cancel the setup, press **MENU** twice.

4 Press **RECORD/PAUSE** to place Camcorder in stand-by mode.

```

STAND-BY
START : 10:30PM
REC TIME : 10MIN.
10:20:00PM
JUN 1 1999
    
```

Recording will be done as scheduled.

→ 10MIN. → 20MIN. → 30MIN. → TO TAPE END

INTERVAL *2 INTERVAL *1
10 SEC/MIN. ← 5 SEC/MIN. ←

***1 Interval 5 SEC/MIN:**
Record 5 seconds each minute.

***2 Interval 10 SEC/MIN:**
Record 10 seconds each minute.

Note:

- Start time may not be set over 24 hours from current time.
- Camcorder shuts off at tape end, or 12 hours after Interval Recording starts.
- To cancel, set POWER to OFF.

Playing Back Recordings

Playback on EVF or LCD Monitor

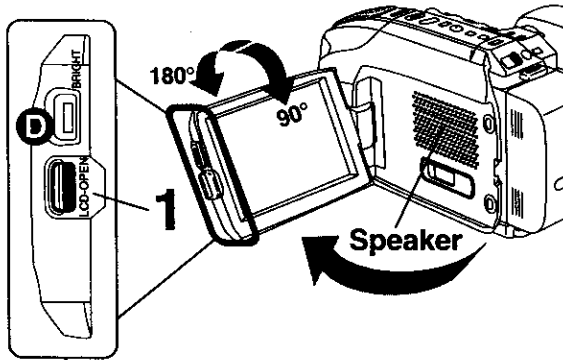

Before you begin...

- Connect Camcorder to power source.
- Insert recorded tape.

1 Press **LCD-OPEN** and swing LCD monitor fully open.

- If you want to playback on EVF, close and lock LCD completely.

2 Set **POWER** to **VCR**.

- If tape has no record tab, auto playback begins.
- LCD monitor turns on/off by the **POWER** switch.
- Viewfinder shuts off when LCD is fully opened and turns back on when LCD is locked shut.
- Return LCD monitor to locked position when not in use.

3 Playback function buttons.

- A** **REW(ind)** : Rewind tape.
- B** **PLAY** : Play tape.
- C** **STOP** : Stop tape.
- D** **BRIGHT** : Adjust LCD brightness.
- E** **VOLUME** : Adjust volume of speaker, or earphone if connected.

Press "T" : Volume up(+).

Press "W" : Volume down(-).

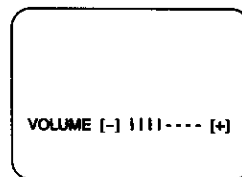
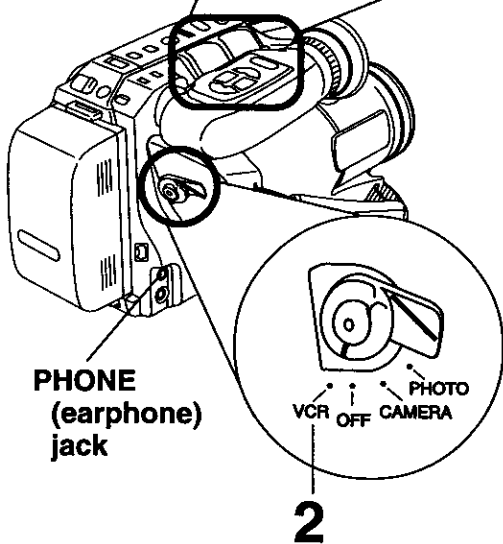
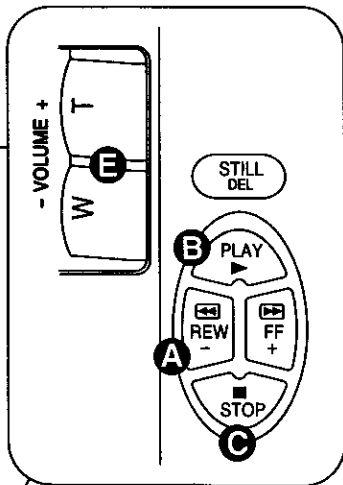

Note:

- Using LCD reduces battery operating time.
- When earphone (M3 type: not supplied) is connected to PHONE jack, speaker is muted.

Playing Back Recordings

1/2 Slow Play

Available only with SP recordings made on this Palmcorder.

Before you begin...

- Connect Palmcorder to power source.
- Insert tape recorded in SP mode.
- Set POWER to VCR.

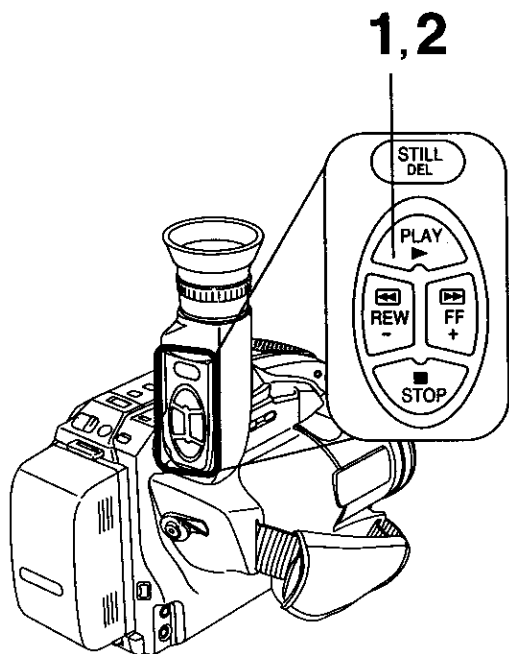

- 1** During playback, press **PLAY** for 1/2 Slow Play mode. Audio is muted.
 - Picture noise will occur in 1/2 slow play.
 - If the recorded speed changes from SP to SLP, normal speed playback is resumed.

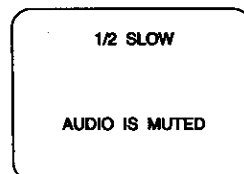

- 2** Press **PLAY** again to resume normal speed playback.

Note:

- Vertical jitter may occur during playback.
- Skew may occur at top of picture.

Playing Back Recordings

Special Effects

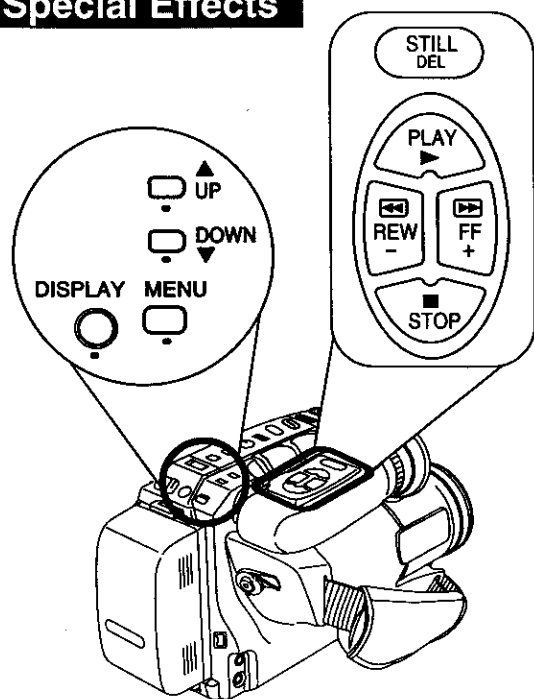

Note:

- During search, horizontal noise bars will appear. Audio is muted.
- To protect video heads and tape, operating modes will revert as follows after 5 minutes:
Still → Stand-by
Stand-by → Power off (when Battery Pack is used).
- Tape auto-rewinds if played or fast forwarded to end.

Tracking Control

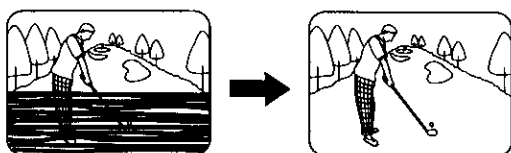

Auto Tracking

Continuously analyzes each recording for optimum picture quality.

Manual Tracking

Some recordings require manual adjustment to reduce noise.

In Playback mode:

Press **UP ▲** or **DOWN ▼** until Playback picture clears up.
Press **DISPLAY** to return to Auto Tracking.

In Still mode:

Press **UP ▲** or **DOWN ▼** until Still picture clears up.
Press **DISPLAY** to return to Auto Tracking.

V-Lock Control

Reduces jitter in Still mode.

Hold down **DISPLAY** and **UP ▲** or **DOWN ▼** until picture is stable.

Before you begin...

- Connect Palmcorder to power source.
- Insert recorded tape.
- Set POWER to VCR.

Quick Visual Search

Search Speed

SP (Standard Play) : 3 times normal.
SLP (Super Long Play) : 9 times normal.

During playback, press:

FF : fast forward search

REW : rewind search

Press again or PLAY for normal play.

Still Picture

Press **STILL** to freeze picture.

Press again for normal play.

Playing Back Recordings

TV Playback or Viewing

Connect Camcorder to a TV to view playback or recordings in progress.

TV with AUDIO/VIDEO IN Jacks.

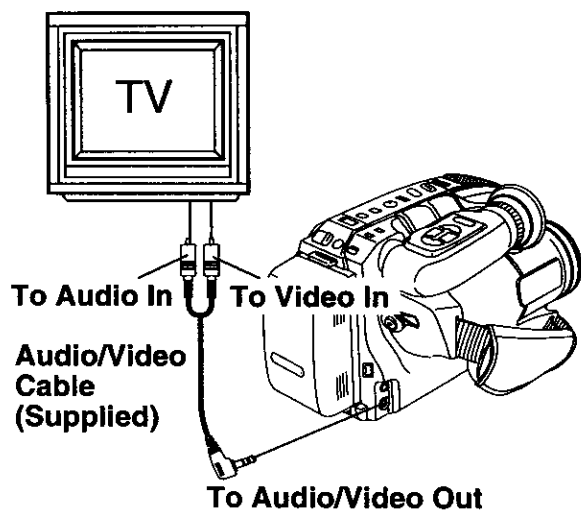

Before you begin...

- Connect Camcorder to power source.
- Make all TV-Camcorder connections.

- 1 Set POWER to:
VCR → view playback.
CAMERA → view picture as it is recorded.
- 2 Turn TV ON and set to LINE INPUT.
See TV owner's manual.
- 3 Begin playback or recording.

TV without AUDIO/VIDEO IN Jacks.

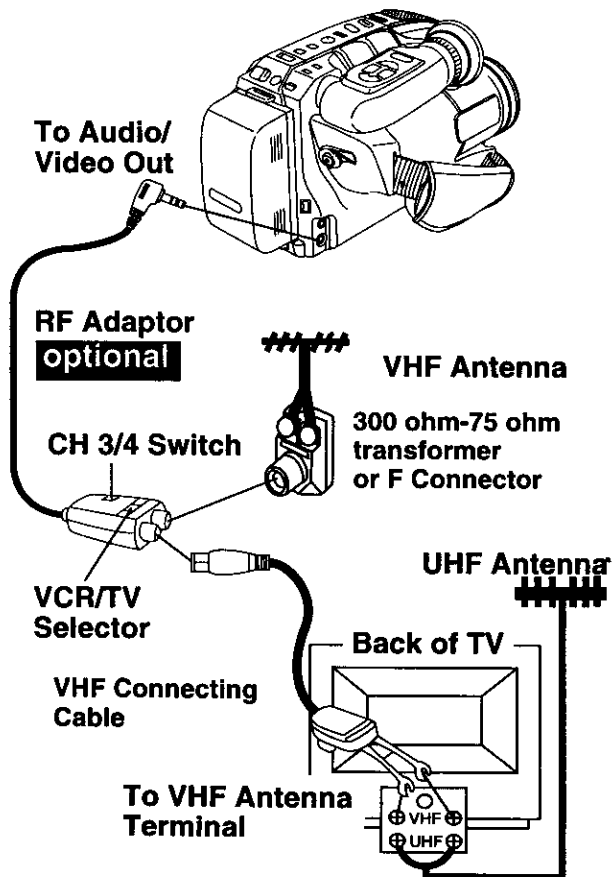

If TV has no VIDEO/AUDIO IN jacks, connect **PV-RF16 RF Adaptor** (optional, page 76). Tune TV to CH 3 or 4 to match RF Adaptor 3/4 switch. Set Adaptor's TV/VCR switch to VCR for playback.

To watch TV only, turn TV on without AUDIO/VIDEO IN Jacks connected (left).

- a Set Camcorder POWER to OFF.
- b Set RF Adaptor VCR/TV Selector to TV.
- c Turn TV ON and select channel.

CATV System Installer

This reminder is provided to call the CATV system installer's attention to Article 820-40 of the NEC in USA (and to the Canadian Electrical Code in Canada) that provides guidelines for proper grounding and, in particular, specifies that the cable ground shall be connected to the grounding system of the building, as close to the point of cable entry as practical.

· *Playing Back Recordings in a VCR*

Load Battery in PlayPak

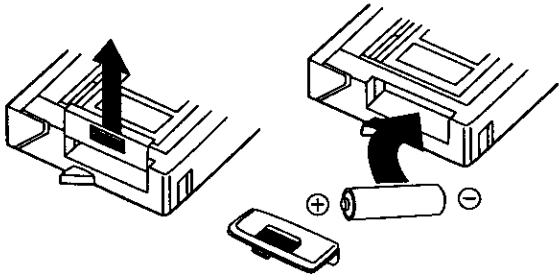

Remove Battery lid and insert AA battery.

- Do not reverse polarity.
- Replace battery when tape loading/unloading takes longer than usual.

Insert VHS Cassette in PlayPak

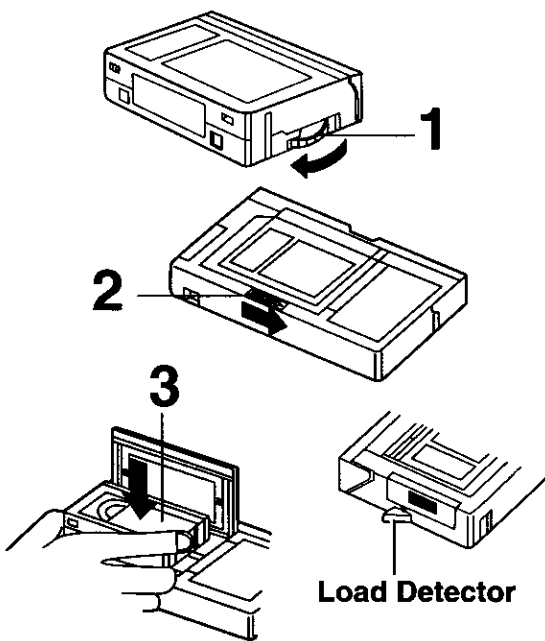

1 Turn **VHS** cassette **Tape Wheel** in direction of arrow to take up any slack.

2 Slide **RELEASE** to open cassette lid.

3 Insert the **VHS** cassette with the window up and on the left, then snap lid shut.

- Do not obstruct cassette reel while loading.
- Allow PlayPak Load Detector to fully retract before using in VHS VCR.

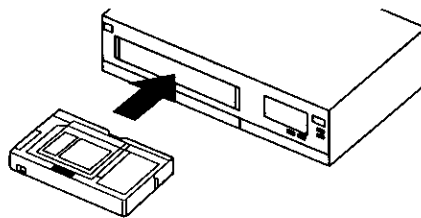

Remove VHS Cassette

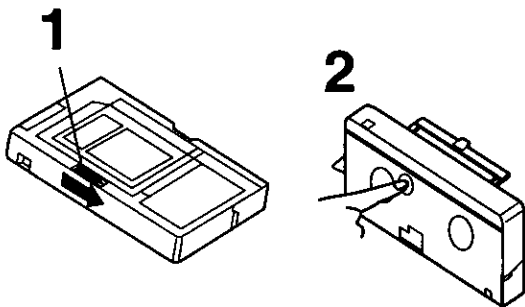

1 Slide **RELEASE** and wait for lid to open.

2 Push cassette out through hole in bottom of PlayPak with your finger.

Copying your Tapes (dubbing)

Connections

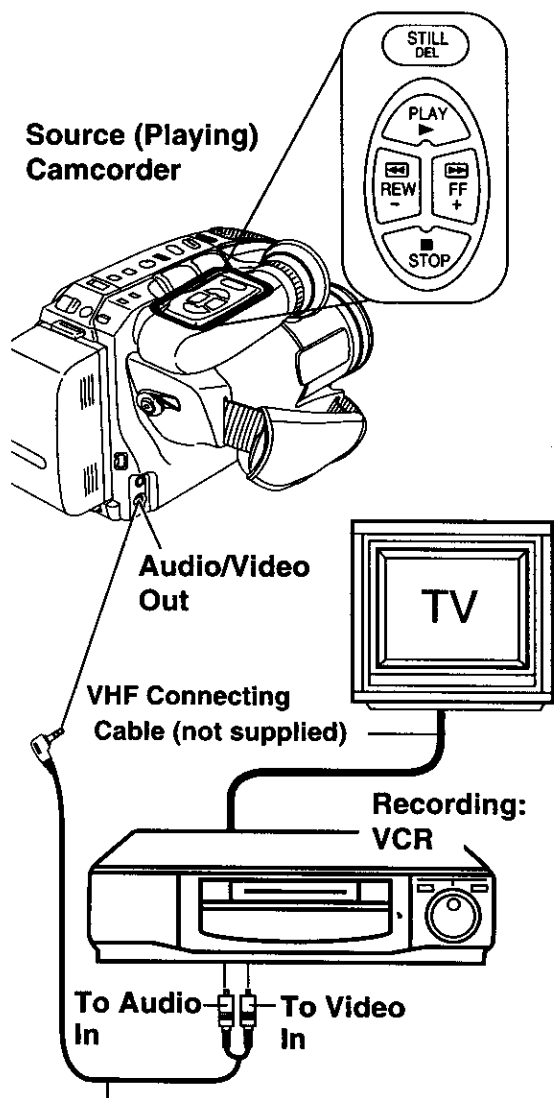

Audio/Video Cable (supplied)

Monitor with your TV

- Turn TV on and tune to VCR channel (CH3 or CH4).
- Set VCR/TV Selector on VCR to VCR.

Before you begin...

- Make Camcorder-VCR connections (see left).
- Turn both units on.
- Set VCR input signal to LINE. Please see VCR owner's manual.
- Set Camcorder POWER to VCR.

- 1** Insert a pre-recorded tape into Camcorder and a blank tape with record tab into VCR.
- 2** Press **PLAY** on Camcorder, then press **STILL** at starting point.
- 3** Press **REC**, then **STILL/PAUSE** on VCR.
- 4** Press **STILL** on Camcorder and **STILL/PAUSE** on VCR again to start copying.
- 5** Press **STOP** on both units to stop copying.

Note:

- Camcorder will only playback tapes recorded in SP or SLP mode.
- Dubbing may reduce picture quality.

CAUTION:

Unauthorized exchanging and/or copying of copyrighted recordings may be copyright infringement.

Power Zoom / Backlight

Four-Speed Power Zoom

Zoom in (close up) and out (wide angle) in one of four speeds ranging from slow (16 sec.) to fast (2 sec.).

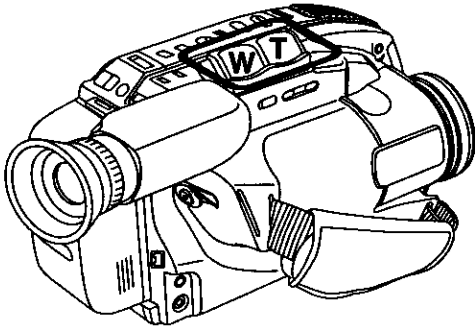

Before you begin...

- Connect Camcorder to power source.
- Set POWER to CAMERA.

Zoom In ("T")



Zoom Out ("W")

Zoom slowly:

Lightly press "T" (telephoto) or "W" (wide angle) POWER ZOOM button.

Zoom quickly:

Apply more pressure to the button.

Backlight

Use when subject is darker than surroundings, in shadowed area, or in front of the light source.

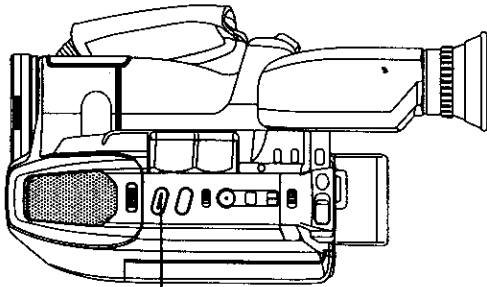

BACKLIGHT

Before you begin...

- Connect Camcorder to power source.
- Set POWER to CAMERA.

Press **BACKLIGHT** while recording to select the level of backlight compensation.

In normal lighting, press **BACKLIGHT** repeatedly until no indicator displayed.

EVF Indications

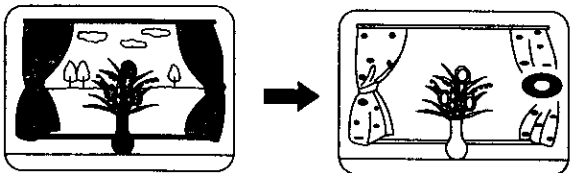
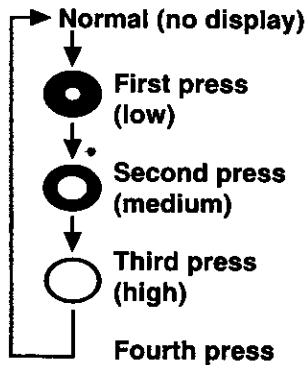

Focus

Auto Focus

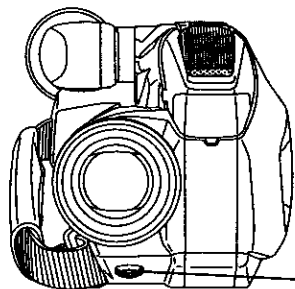

MANUAL FOCUS

Before you begin...

- Connect Camcorder to power source.
- Set POWER to CAMERA.

Camcorder automatically focuses on subject even during zooming.

Auto Focus is on when "MF" is not displayed in EVF. Push **MANUAL FOCUS** to remove "MF" in EVF if necessary.

Manual Focus

Use Manual Focus (MF) when :

- recording through glass.
- lighting is poor.
- subject is far away with objects in foreground.
- subject has distinct horizontal lines.

- subject is not centered in Viewfinder.
- subject has shiny surface.
- subject is slanted.
- subject is bright and flat, like a white wall.
- subject has fast motion, like a golf swing.

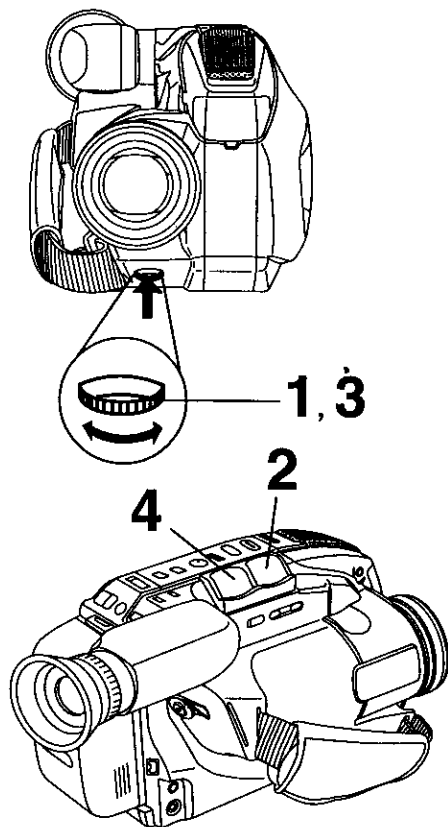

- 1 Push **MANUAL FOCUS** so "MF" (Manual Focus) appears in EVF.

EVF Indication



- 2 Hold down "**T**" (**telephoto**) on **POWER ZOOM** to maximum zoom in.
- 3 Turn **MANUAL FOCUS** until subject is in focus.
 - Back away from subject if necessary.
- 4 Hold down "**W**" (**wide angle**) on **POWER ZOOM** as desired.
 - **Refocus as needed** when aiming at new scenes.

Macro Focus (close-ups)

Auto Focus functions up to 1/2 inch (12.7mm) from subject.

Hold down "W" on POWER ZOOM to maximum wide angle.

Bring Camcorder up close to the subject.

High Speed Shutter

Improves Still or Slow Motion playback picture of high speed subjects (e.g. a tennis stroke), when viewed on Camcorder or 3 or 4 head VCR.

Before you begin...

- Connect Camcorder to power source.
- Set POWER to CAMERA.
- Insert cassette with record tab (page 14).

Auto Shutter

In AUTO mode (no indication in EVF), shutter speed is auto-adjusted from 1/60 to 1/350 according to subject brightness.

- AUTO mode is selected each time POWER is set to CAMERA.

Manual Selection

The faster the shutter speed, the more light is needed for proper picture and color quality. High Speed Shutter indication flashes if light is inadequate. Provide additional light.

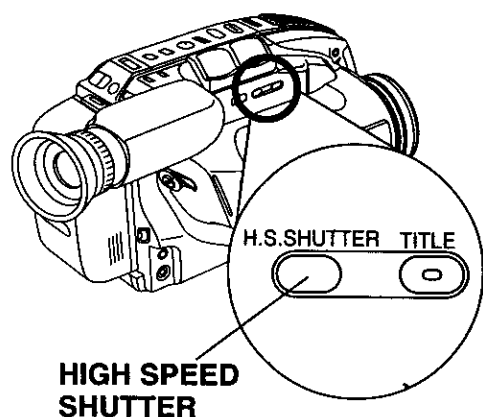

1 Press **HIGH SPEED SHUTTER** while recording.

2 Press repeatedly to change shutter speed. (See below, left.)

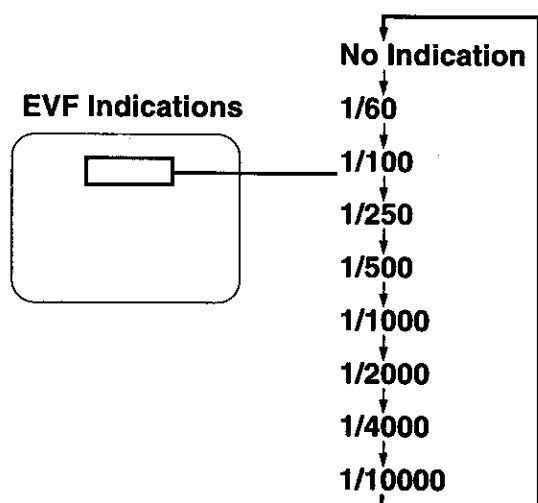

Note:

- Provide additional halogen or tungsten light for use indoors or in poor light. Fluorescent light degrades picture.
- Auto Focus may not function properly if high speed shutter is used in inadequate light.
- Setting reverts to AUTO each time POWER is set to CAMERA.

Tally Lamp

Tally Lamp

The tally lamp can be set to come on or stay off during recording.

New camcorder's default setting is ON.

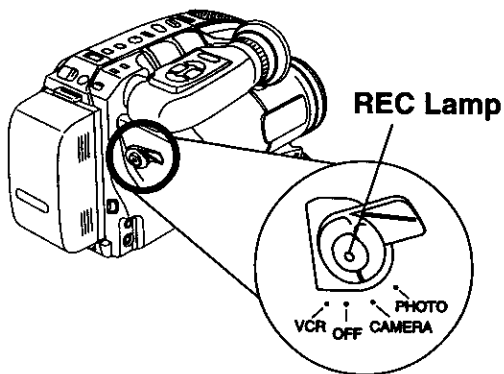
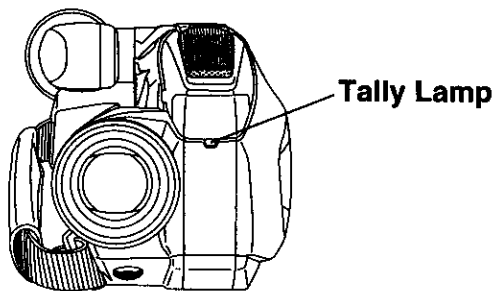
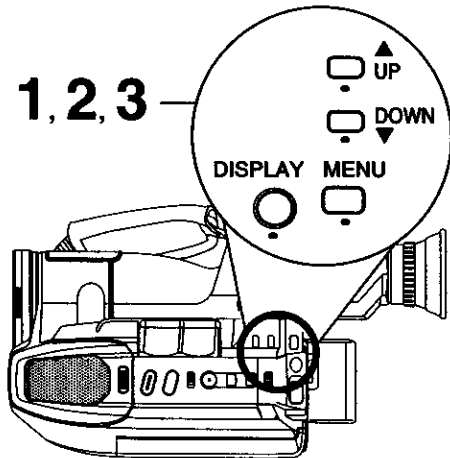

Before you begin...

- Connect Camcorder to power source.
- Set POWER to CAMERA.
- Insert cassette with record tab (page 14).

- 1** Press **MENU** for MENU mode.
Press **UP ▲** or **DOWN ▼** to select **TALLY LAMP**.

```
--- MENU --- PAGE 1/2
PROGRAMMED REC
TITLE      : AUTOMANUAL
TALLY LAMP : ON
STAND-BY RELEASE : OFF
CLOCK SET
SELECT : PUSH ▼/▲ KEY
SET    : PUSH DISPLAY KEY
END    : PUSH MENU KEY
```

- 2** Press **DISPLAY** to select:
ON → Tally lamp lights during recording.
OFF → Tally lamp and REC lamp stay off.

- 3** Press **MENU** to exit.

Fade In/Out

Auto Fade

An interesting way to open and close scenes.

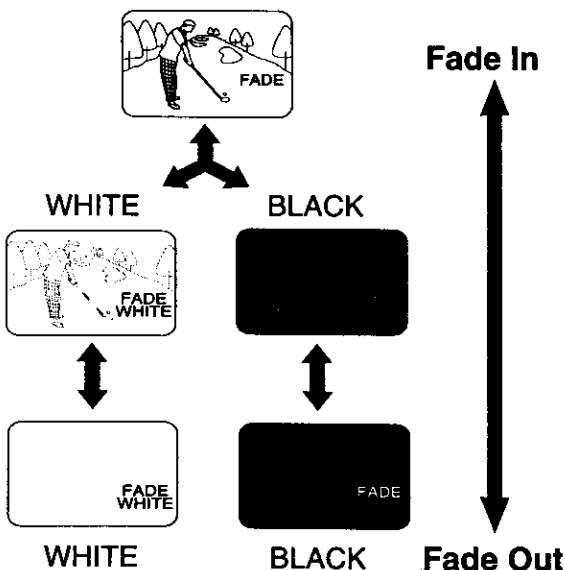
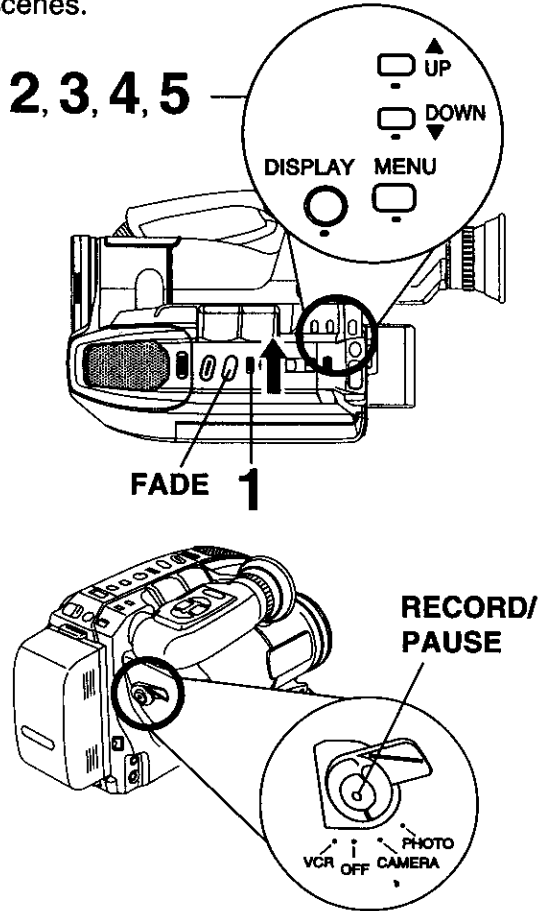

Before you begin...

- Connect Camcorder to power source.
- Set POWER to CAMERA.

1 Slide DIGITAL SELECT to FADE.

2 Press MENU for MENU mode.
Press UP ▲ or DOWN ▼ to select VIDEO EFFECTS.

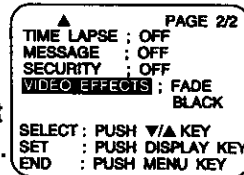

3 Press DISPLAY for VIDEO EFFECTS menu.
Press UP ▲ or DOWN ▼ to select AUTO FADE.

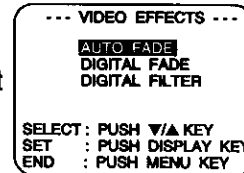

4 Press DISPLAY for AUTO FADE ; COLOR menu.
Press UP ▲ or DOWN ▼ to select BLACK or WHITE.

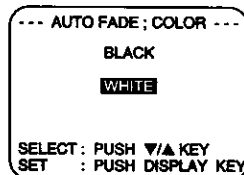

5 Press DISPLAY to confirm entry.
Press MENU to exit.

Fade In:

In RECORD/PAUSE mode, press FADE so "FADE" flashes in EVF.

Press RECORD/PAUSE.

Recording starts as picture and sound gradually fade in.

Fade Out:

While recording, press FADE so "FADE" flashes in EVF.

Press RECORD/PAUSE.

Picture and sound gradually fade out, and recording is paused.

If FADE is pressed accidentally, press again so "FADE" disappears in EVF.

Note:

- Auto Fade will not function during Digital Wipe mode or Picture in Picture Wipe Title.

Fade

Color Digital Fade

Choose from 7 fade effects in 8 different colors.

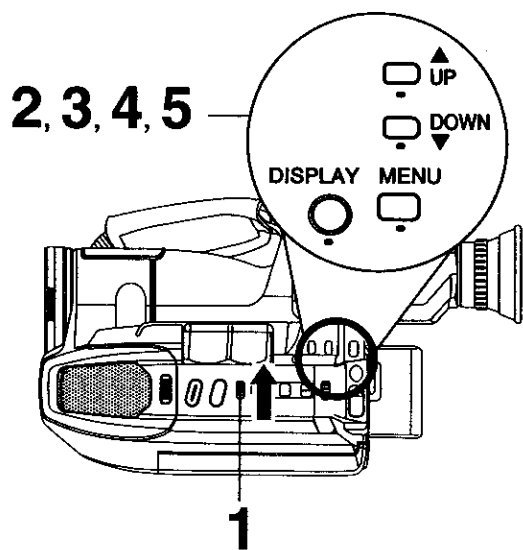

Before you begin...

- Connect Camcorder to power source.
- Set POWER to CAMERA.

1 Slide **DIGITAL SELECT** to **FADE**.

2 Press **MENU** for MENU mode. Press **UP ▲** or **DOWN ▼** to select **VIDEO EFFECTS**.

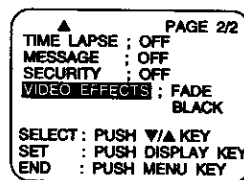

3 Press **DISPLAY** for VIDEO EFFECTS menu. Press **DOWN ▼** to select **DIGITAL FADE**.

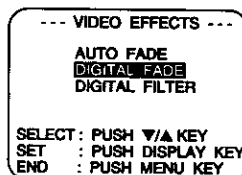

4 Press **DISPLAY** for DIGITAL FADE menu. Press **UP ▲** or **DOWN ▼** to select **TYPE**. Press **DISPLAY** for TYPE menu. Press **UP ▲** or **DOWN ▼** to select from 7 types.

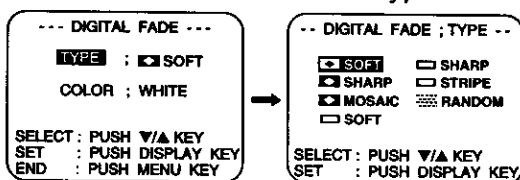

5 Press **DISPLAY** for DIGITAL FADE menu. Press **DOWN ▼** to select **COLOR**. Press **DISPLAY** for COLOR menu. Press **UP ▲** or **DOWN ▼** to select from 8 colors.

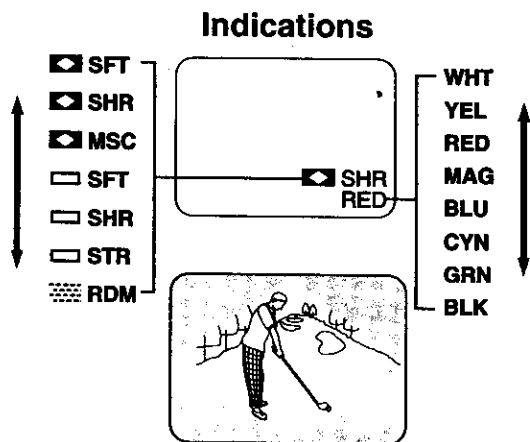
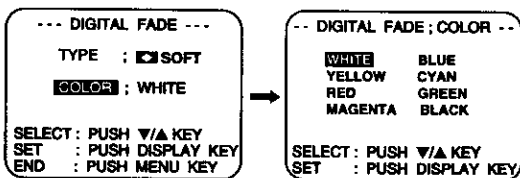

Fade

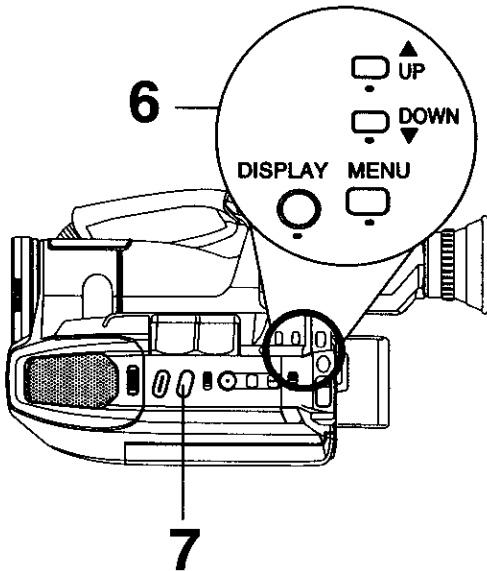

6 Press **DISPLAY** to confirm entry.
Press **MENU** twice to exit.

7 Press **FADE** for about 2 seconds to
fade out during recording (selected
fade type flashes). Press **FADE**
again to fade in.

■ For more effects, stop fade in or fade out
at any time (except RANDOM mode) by
pressing FADE. Then, press FADE to
resume fade.

Note:

- Audio is not affected by fade.
- To cancel Digital Fade, do steps 1, 2, 3, and 6. In step 3, select AUTO FADE.
- Color Digital Fade will not function during Digital Wipe mode or Picture in Picture Wipe Title.

Color Digital Filter

Digital Filter adds one of 5 colors to entire picture, like a color filter.

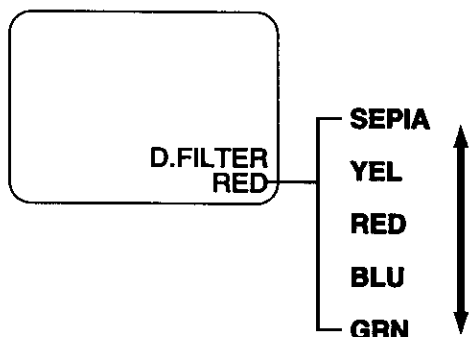
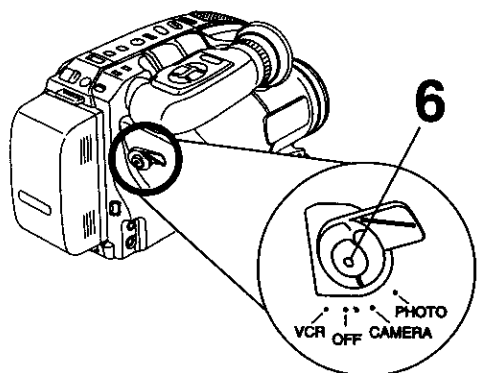
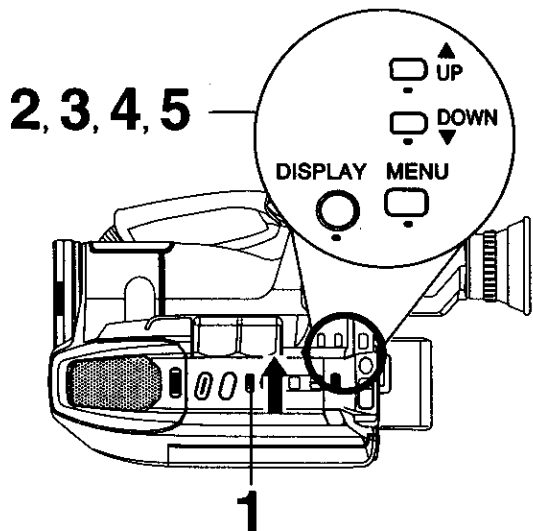

Before you begin...

- Connect Camcorder to power source.
- Set POWER to CAMERA.

1 Slide DIGITAL SELECT to FADE.

2 Press MENU for MENU mode. Press UP ▲ or DOWN ▼ to select VIDEO EFFECTS.

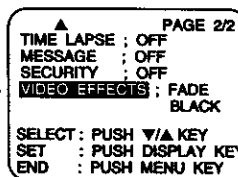

3 Press DISPLAY for VIDEO EFFECTS menu. Press DOWN ▼ to select DIGITAL FILTER.

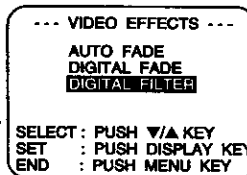

4 Press DISPLAY for DIGITAL FILTER menu. Press UP ▲ or DOWN ▼ to select from 5 colors.

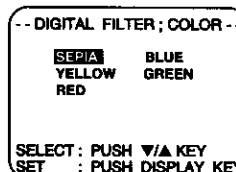

5 Press DISPLAY to confirm entry. Press MENU to exit.

6 Start recording (page 22).

- To cancel Digital Filter, set POWER to OFF.

Note:

- Color Digital Filter will not function during Digital Wipe mode, Picture in Picture Wipe Title or Still/Strobe/Wide.
- Picture returns to normal in Still mode.

Digital Zoom

Power Zoom magnification is digitally increased.

Before you begin...

- Connect Camcorder to power source.
- Set POWER to CAMERA.

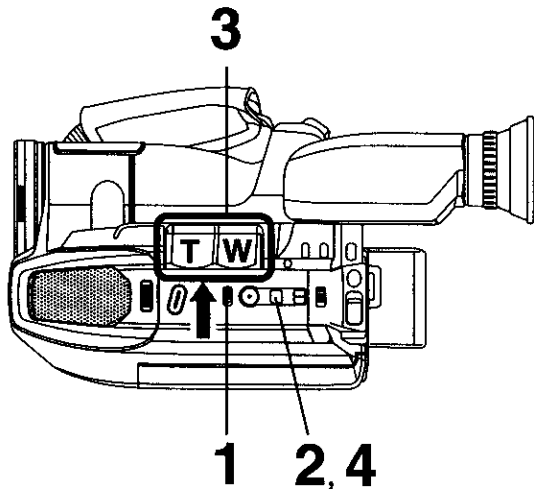

1 Slide **DIGITAL SELECT** to **D.ZOOM**.

2 Press **D. ZOOM**.
once → D.ZOOM 1 (150x maximum)
twice → D.ZOOM 2 (300x maximum)

Higher digital magnification levels may cause picture distortion.

3 Hold down **"T"** on **POWER ZOOM**.
Digital Zoom starts when normal zoom reaches maximum (26x).

- Zoom level appears in EVF.
- POWER ZOOM switch controls digital zoom level.
- Normal zoom resumes when level falls to 26x.

4 Press **D. ZOOM** to turn off Digital Zoom so no indication appears.

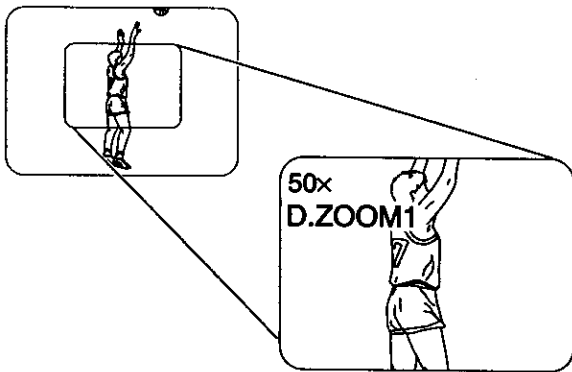

Note:

- If "NOW IN DIGITAL WIPE" is displayed when D. ZOOM is pressed, DIGITAL SELECT is currently in DIGITAL WIPE mode and the DIGITAL ZOOM feature is not available.

Digital E.I.S.

Digital Electronic Image Stabilization (E.I.S.)

Helps stabilize picture when recording in unstable situations.

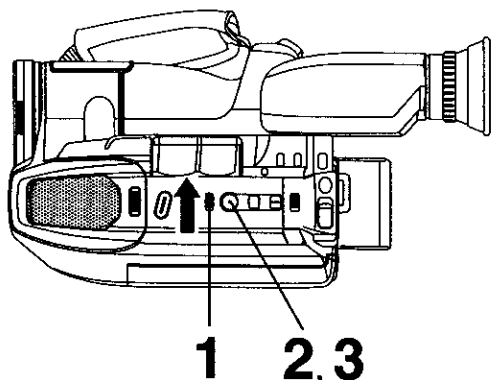

NORMAL

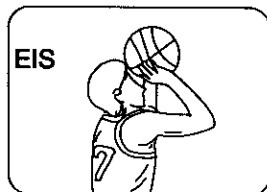

Digital EIS ON

Before you begin...

- Connect Camcorder to power source.
- Set POWER to CAMERA.

1 Slide **DIGITAL SELECT** to **EIS**.

2 Press **EIS** to display "EIS" in the EVF.

- The shutter speed auto-adjusts from 1/80 to 1/350 according to brightness.
- Use High Speed Shutter (page 35) if needed. Shutter speed setting remains after EIS is canceled.

3 Press **EIS** again to cancel when not in use.

E.I.S. may not function during...

- extreme Camcorder movement.
- recording of subject with distinct horizontal or vertical stripes.
- low light situations (EIS indicator flashes).
- intense fluorescent lighting situations.
- recording of very fast motion.

Note:

- If "NOW IN DIGITAL WIPE" is displayed when EIS is pressed, DIGITAL SELECT is currently in DIGITAL WIPE mode and the Digital E.I.S. feature is not available.

Still/ Strobe/ Wide

Before you begin...

- Connect Camcorder to power source.
- Set POWER to CAMERA.

1 Slide **DIGITAL SELECT** to **STILL/STROBE**.

2 Press **STILL/STROBE** repeatedly for desired function as described below.

Selection order

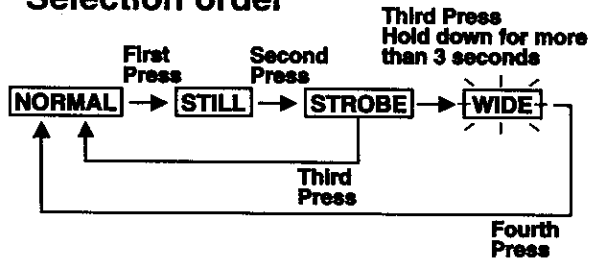

STILL

Records a still image from the current picture.

STROBE

Records a progression of still images in 1/6 of a sec. intervals.

WIDE SCREEN

Records a picture that will fill entire screen of a wide screen (16×9 aspect ratio) TV.

- Picture appears distorted in EVF.

Note:

- If "NOW IN DIGITAL WIPE" is displayed when STILL/STROBE is pressed, DIGITAL SELECT is currently in DIGITAL WIPE mode and the STILL/STROBE/WIDE feature is not available.
- Wide screen recordings must be played back on a wide screen TV (16×9 aspect ratio) or picture will be distorted.
- If title is added (pages 48~50) during Wide mode, it will be distorted when played back on a wide screen TV.

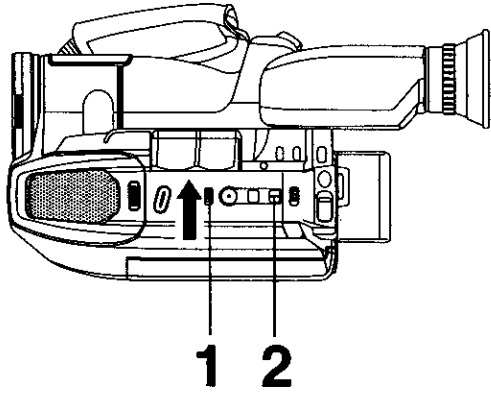

Still

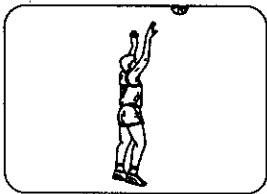

Strobe

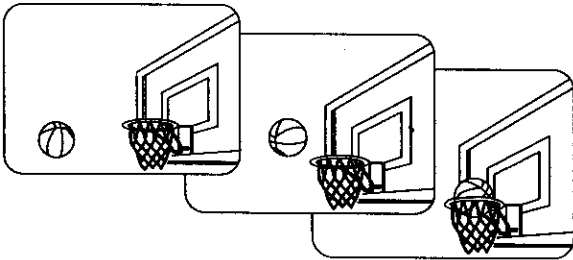

Wide Screen

EVF

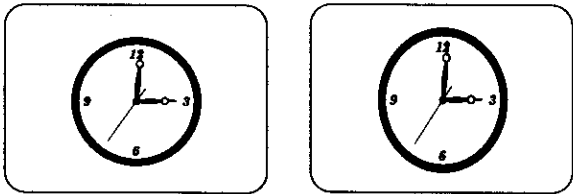

Normal



Wide

Security Mode

Motion Security

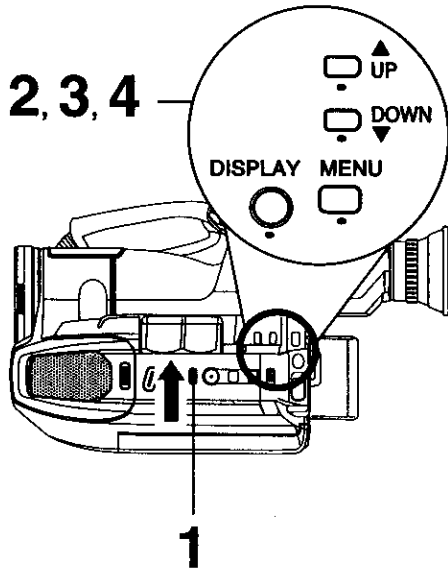

Motion Security may mistakenly start when:

- background is plain, like a white wall, or has distinct vertical, horizontal or slanted stripes, like a venetian blind.
- brightness suddenly changes.

Motion Security may not start when:

- motion is very slow or fast.
- moving object is very small.
- motion occurs only in 1 corner of viewing area.
- in poor lighting (in this case, MOTION SECURITY flashes).
- background is plain, like a white wall, or has distinct horizontal or vertical stripes.

Note:

- Security recording starts if Camcorder is bumped or repositioned.
- This feature is not available during normal recording.
- While in Motion Security stand-by, the following functions are not available: Record/Pause, Stand-by mode, Digital E.I.S., Time Lapse, Message, Auto Fade, Digital Fade, Digital Filter.

Before you begin...

- Connect Camcorder to power source. Use AC Adaptor for longer recordings.
- Insert cassette with record tab (page 14).
- Set POWER to CAMERA.
- Securely position and aim Camcorder.

1 Slide **DIGITAL SELECT** to **EIS**.

2 Press **MENU** for MENU mode. Press **UP ▲** or **DOWN ▼** to select **SECURITY**.

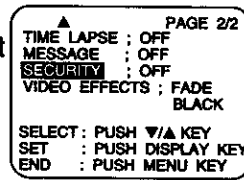

3 Press **DISPLAY** for SECURITY MODE menu. Press **UP ▲** or **DOWN ▼** to select **MOTION**. Press **DISPLAY** to confirm entry.

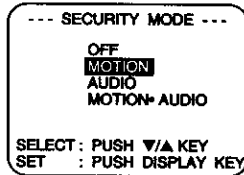

4 Press **MENU** for Motion Security stand-by mode. (If cassette is not inserted, "⏏" will flash.)

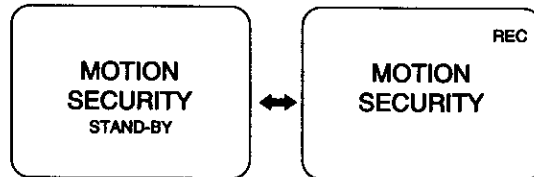

- Recording will start about 3 seconds after motion is detected.
- Date and time are recorded if displayed in EVF (page 20).
- Recording stops 30 seconds after motion ceases.

To cancel Security Mode, set POWER to OFF.

Security Mode

Audio Security

Choose HIGH or LOW Audio sensitivity for Audio or Motion•Audio Security.

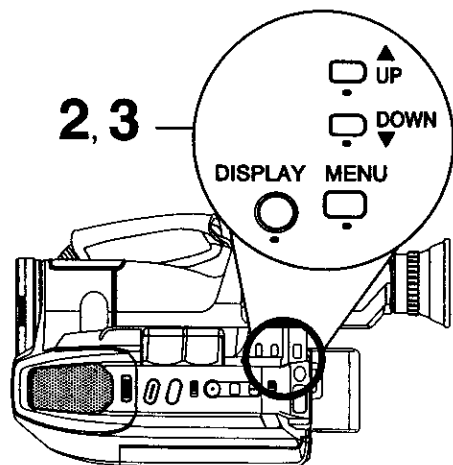

Audio Security may start when:

- mic picks up any wind noise.

Audio Security recording may not start when:

- sound is too brief.

Note:

- Audio Security may mistakenly start when normal noises are picked up. To avoid this, place in quiet area.
- Camcorder location should be considered when adjusting Audio sensitivity.
- Performance may vary due to spaciousness of area, noise reflection, and resonance.
- Do a test to confirm performance.
- While in Audio Security stand-by, the following functions are not available: Record/Pause, Stand-by mode, Digital E.I.S., Time Lapse, Message, Auto Fade, Digital Fade, Digital Filter.

Before you begin...

- Connect Camcorder to power source. Use AC Adaptor for longer recordings.
- Insert cassette with record tab (page 14).
- Set POWER to CAMERA.
- Securely position and aim Camcorder.

1

Make sure that SECURITY, in the Menu mode, is set to AUDIO or MOTION•AUDIO in page 44 steps 1-3.

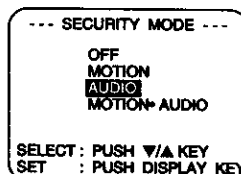

2

Press **DISPLAY** for AUDIO SENSITIVITY menu. Press **UP ▲** or **DOWN ▼** to select HIGH or LOW.

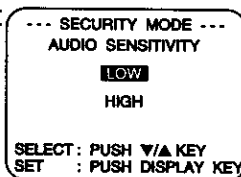

HIGH

Picks up normal voices up to about 32.8 feet (10m) away.

LOW

Picks up normal voices up to about 3.2 feet (1m) away.

3

Press **DISPLAY** to confirm entry. Press **MENU** for Audio Security stand-by mode or Motion•Audio Security stand-by mode. (If cassette is not inserted, "⏏" will flash.)

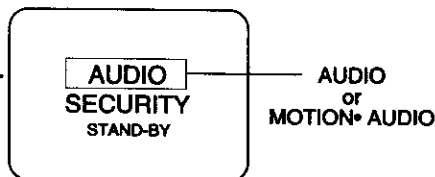

- Recording will start about 3 seconds after motion and/or audio is detected.
- Date and time are recorded if displayed in EVF (page 20).
- Recording stops 30 seconds after motion and/or audio ceases.

To cancel Security Mode, set POWER to OFF.

Time Lapse

This feature reduces tape speed to 1/3 SLP for long term period recording (up to 6 hours with TC-40 tape).

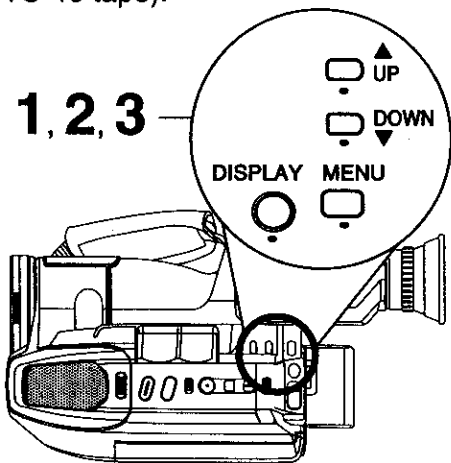

Before you begin...

- Connect Camcorder to power source. Use AC Adaptor for longer recordings.
- Insert cassette with record tab (page 14).
- Set POWER to CAMERA.
- Slide TAPE SPEED to SLP.

- 1 Press **MENU** for MENU mode. Press **UP ▲** or **DOWN ▼** to select **TIME LAPSE**.

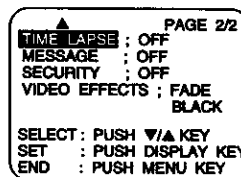

- 2 Press **DISPLAY** to select ON. **TIME LAPSE; ON**

Records at 1/3 SLP speed (up to 6 hours). Playback will be normal SLP speed. Sound is muted.

- 3 Press **MENU** to exit.

- 4 Start recording (page 22).

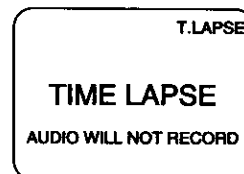

In Time Lapse mode...

- Picture quality is degraded.
- Video noise may occur during playback.
- SP/SLP, titles, and 10-Second Reminder will not be displayed.
- Interval REC is not available.
- During playback, vertical jitter may occur depending on monitor used.

IMPORTANT:

- Time Lapse recording system is not part of VHS standard. Therefore, time lapse recordings should be played back on Camcorder only.
- Recordings other than time lapse may be played back on any **VHS** camcorder or **VHS** VCR.

To cancel Time Lapse, select OFF in step 2 above.

Note:

- If Time Lapse mode is selected, the following functions are not available: Message, Security.

Message Mode

Leave audio/video messages for family or friends.

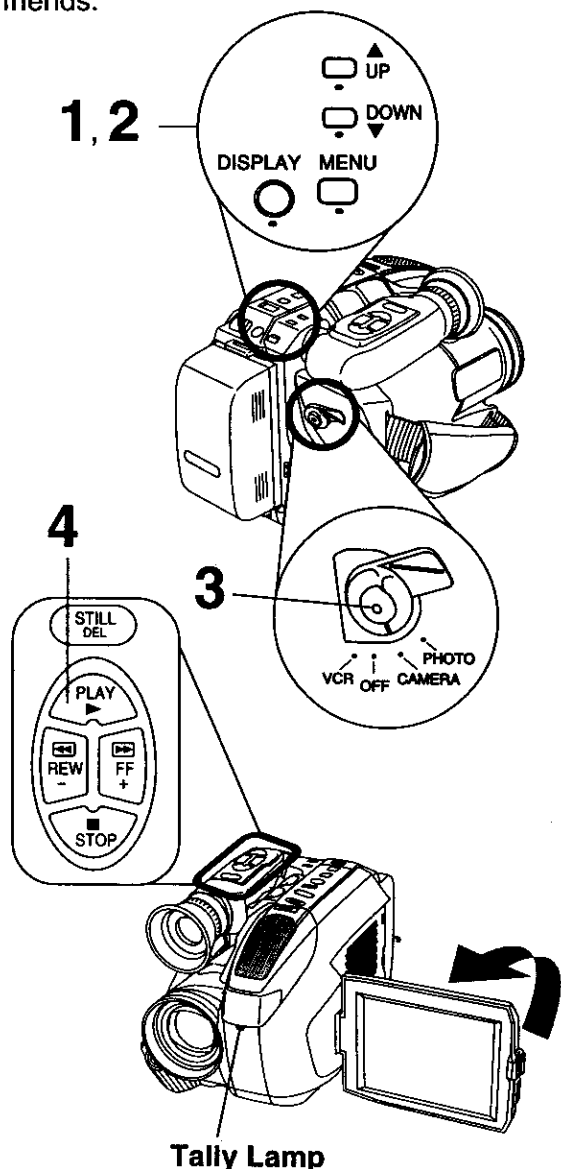

Tally Lamp

Note:

- One message limit.
- If tape is ejected or battery (if used) is depleted while in Stand-by mode, the message mode is canceled. To playback message (tape is inserted and/or new power source is attached), set **POWER** to **VCR** and press **PLAY**.
- Title cannot be displayed in Message mode.
- If Message mode is selected, the following functions are not available: Time Lapse, Security.

Before you begin...

- Connect Camcorder to power source. Use AC Adaptor for extended use.
- Insert cassette with record tab (page 14).
- Set **POWER** to **CAMERA**.

1

Press **MENU** for MENU mode.

Press **UP ▲** or **DOWN ▼** to select **MESSAGE**: Press **DISPLAY** to select ON.

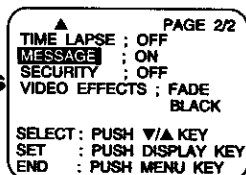

2

Press **MENU** for Message Stand-by Mode. (If cassette is not inserted, "RECORD" will flash.) Flip LCD in direction of lens.

3

Press **RECORD/ PAUSE** to start recording your message.

- Tally lamp flashes and a display alerts recipient.

Press **RECORD/ PAUSE** to end.

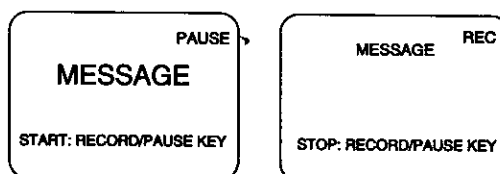

- Camcorder auto-rewinds to the message start, then goes into Stand-by mode.

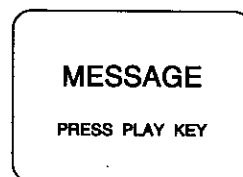

4

Press **PLAY** to playback message.

- LCD can be in any position for playback.
- To cancel feature, set **POWER** to **OFF**.

Intelligent Titler

Automatic Title

Camcorder auto-displays title greeting on selected holidays when power is first turned on. See title list on page 49.

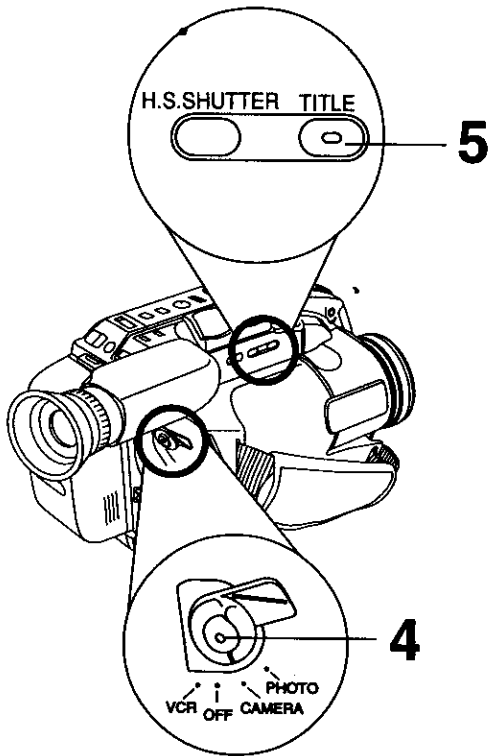
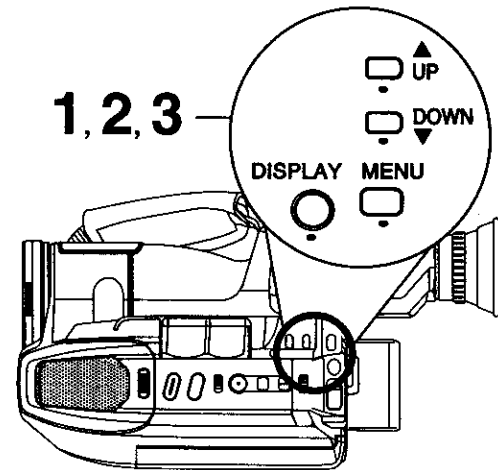

Before you begin...

- Connect Camcorder to power source.
- Set POWER to CAMERA.
- Insert cassette with record tab (page 14).

1 Press **MENU** for MENU mode. Press **UP ▲** or **DOWN ▼** to select **TITLE**.

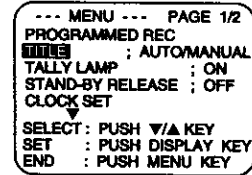

2 Press **DISPLAY** to select AUTO/MANUAL.

3 Press **MENU** to exit.

4 To record the title, press **RECORD/PAUSE**.

5 Press **TITLE** to remove title during recording.

Note:

- Once removed, title will not be auto-displayed. To redisplay, or select from other titles use Manual Title (page 49).

Intelligent Titler

Automatic/Manual Title Display List

Dec. 31–Jan. 1	HAPPY NEW YEAR! / CHEERS!
Feb. 14	VALENTINE'S DAY / BE MY VALENTINE
2nd Sunday in May	HAPPY MOTHER'S DAY / WE LOVE YOU!
Last Monday in May	MEMORIAL DAY
3rd Sunday in Jun.	HAPPY FATHER'S DAY / WE LOVE YOU!
Jul. 4	INDEPENDENCE DAY
1st Monday in Sep.	LABOR DAY
Oct. 31	HAPPY HALLOWEEN
4th Thursday in Nov.	HAPPY THANKSGIVING
Dec. 24–25	MERRY CHRISTMAS / HO! HO! HO!
These Titles must be displayed manually.	HAPPY EASTER HAPPY ANNIVERSARY HAPPY BIRTHDAY VACATION WEDDING DAY A SPECIAL DAY

Manual Title

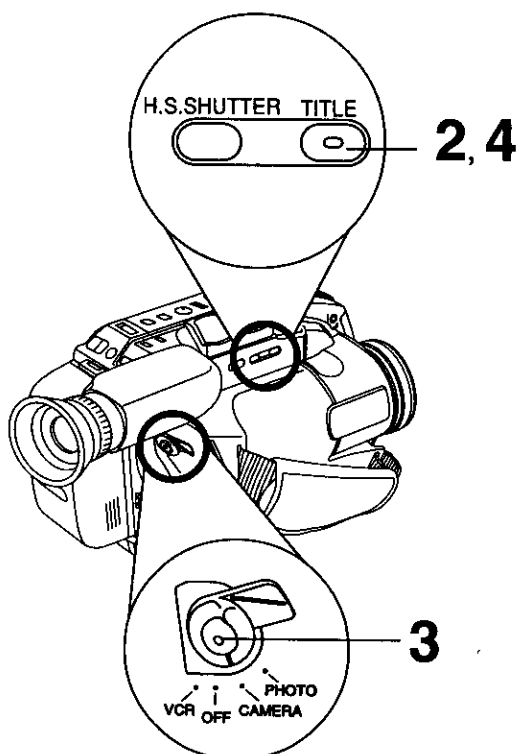

Before you begin...

- Connect Camcorder to power source.
- Set **POWER** to **CAMERA**.
- Insert cassette with record tab (page 14).

- 1** Confirm that **TITLE: AUTO/MANUAL** is set in Menu mode (steps 1~3, page 48).
- 2** In Pause (Record mode), press **TITLE repeatedly** to display titles from list above.
- 3** To record the title, Press **RECORD/ PAUSE**.
- 4** Press **TITLE** while recording to remove title.

Note:

- To redisplay title, press **TITLE** in Pause (Record mode).

Intelligent Titler

Phrase Title

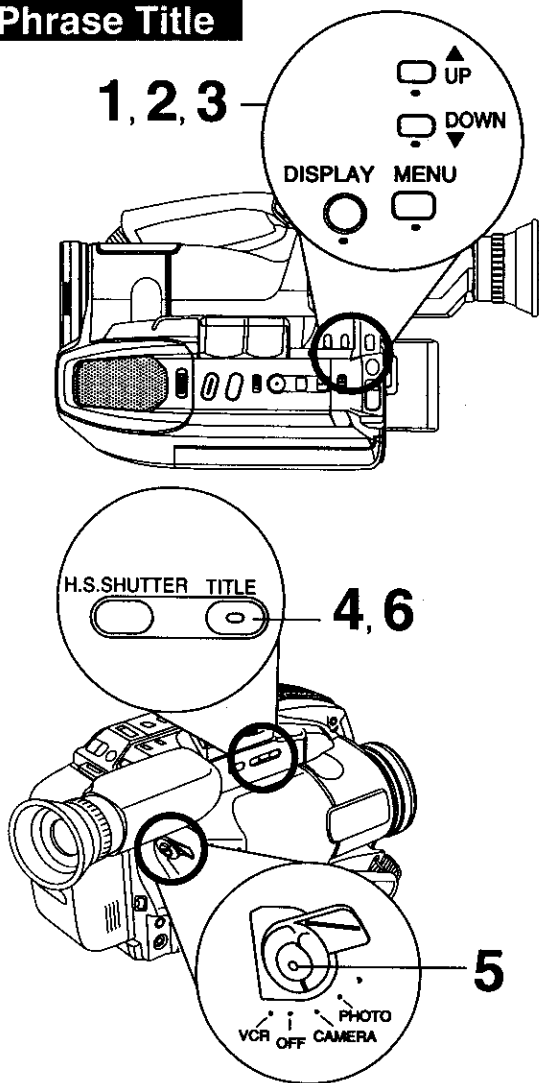

Before you begin...

- Connect Camcorder to power source.
- Set POWER to CAMERA.
- Insert cassette with record tab (page 14).

- 1 Press **MENU** for MENU mode.
Press **UP ▲** or **DOWN ▼** to select **TITLE**.

```

--- MENU --- PAGE 1/2
PROGRAMMED REC
TITLE : PHRASE
TALLY LAMP : ON
STAND-BY RELEASE : OFF
CLOCK SET
SELECT : PUSH ▼/▲ KEY
SET : PUSH DISPLAY KEY
END : PUSH MENU KEY
    
```

- 2 Press **DISPLAY** to select PHRASE.

- 3 Press **MENU** to exit.

- 4 In Pause (Record mode), press **TITLE** repeatedly to display phrases from list below, left.

- 5 To record the phrases, Press **RECORD/PAUSE**.

- 6 Press **TITLE** while recording to remove phrase.

Note:

- To redisplay phrase, press TITLE in Pause (Record mode).

(no indication)

BEAUTIFUL

↓

BRAVO!

↓

CHEERS!

↓

CONGRATULATIONS

↓

GIMME A BREAK!

↓

GOOD LUCK

↓

I LOVE YOU

↓

OOPSI!

↓

OUR LITTLE ANGEL

↓

WAY TO GO

Digital Still Camera

CompactFlash Card Insertion/ Removal

The captured images will be stored on this CompactFlash Card.

Be sure to insert the CompactFlash Card before using the Built-in Digital Still Camera.

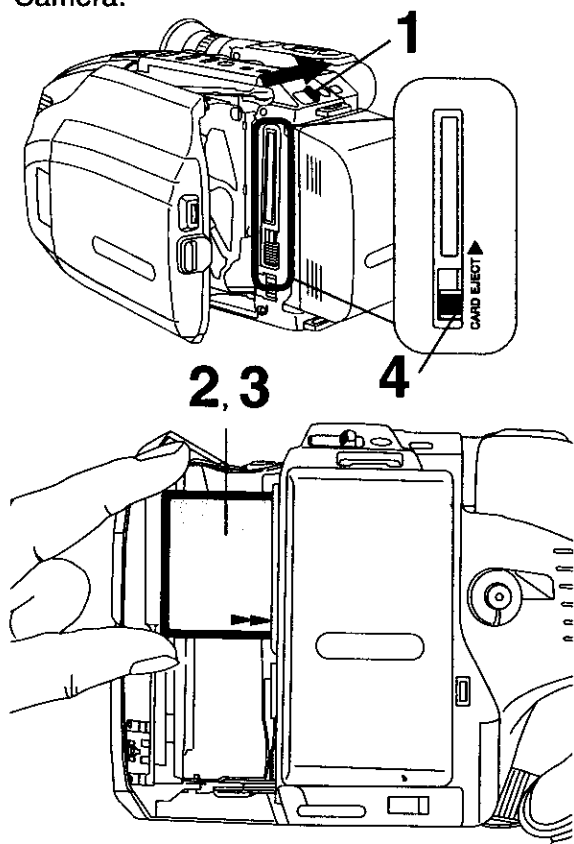

Concerning the CompactFlash Card

- Except for some special features, this card is compatible with other Panasonic brand products, like Digital Camera (PV-DC1080, PV-DC1580), LCD Projector (PT-L556U).
- Panasonic only guarantees compatibility with Panasonic brand cards and those bearing the SanDisk logo.
- This Camcorder can capture a maximum of 400 still images. A larger CF card (optional) is required to capture 400 images.

Before you begin...

- Connect Camcorder to power source.
- Set POWER to OFF.

1

Slide TAPE EJECT to open door.

2

Insert the **CompactFlash Card** into the CompactFlash Card Slot in the direction of the arrow. The side of the card with the arrow faces the back (battery side) of the camcorder (see the picture at the left).

3

Push the card fully into the Slot.

4

Slide CARD EJECT, to release the card.

Note:

- If CompactFlash Card is not inserted, "NO CF CARD" appears on-screen.
- Do not insert card in wrong direction.
- If card does not eject after sliding CARD EJECT, push card fully back into slot, then firmly slide the CARD EJECT again.
- To avoid dropping the card, do not slide CARD EJECT when the card slot is facing downward.
- If "CF CARD ERROR" appears on-screen, see page 80.

CAUTION:

- Do not bend, drop, apply high pressure or subject the card to strong shocks.
- Do not store it in places with high temperature, high humidity, a lot of dust, or places exposed to direct sunlight, or static electricity and strong electromagnetic waves.
- Keep the card's contacts free from dust, water or other foreign substances. Do not touch them with your fingers, etc.
- Do not disassemble or deform the card.
- Be sure to make a backup copy of important data.
- Do not affix other labels to the CompactFlash Card face or back as Card insertion/removal may become impossible.

Special Features

Digital Still Camera

Recording

Before you begin...

- Connect Camcorder to power source.
- Insert the CompactFlash Card (page 51).

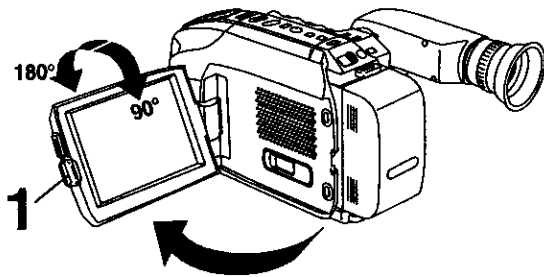

1 Press **LCD-OPEN** and swing LCD monitor fully open. Adjust viewing angle.

2 Set **POWER** to **PHOTO**.
Built-in Lens Cover opens and **POWER** Lamp lights.
• Be sure **POWER** is fully rotated to **PHOTO** position.

3 Slide **PHOTO MODE** to **REC**.

4 Press **MENU** for **REC Mode**.
Press **UP ▲** or **DOWN ▼** to select **NORMAL** or **FINE** (page 71). Then, press **DISPLAY** to set.

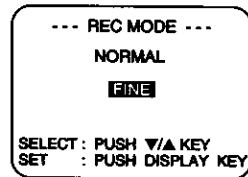
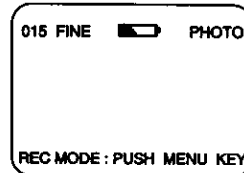
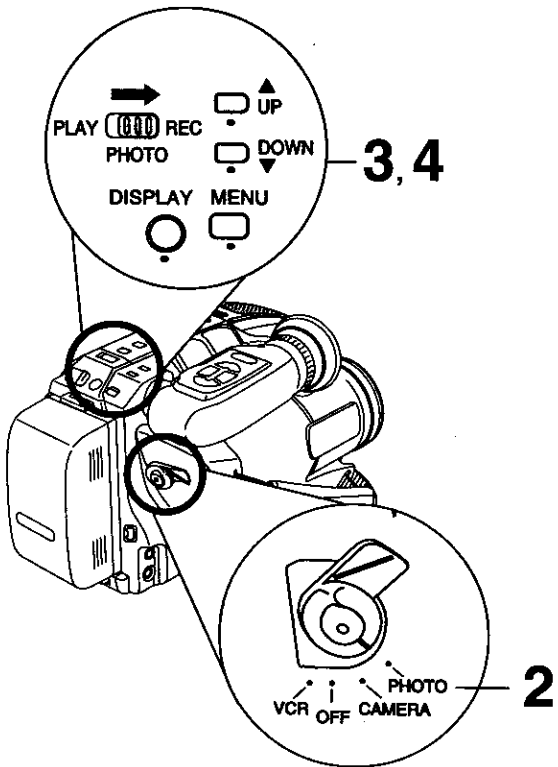

Note:

Please note that the included 2MB CompactFlash Card already contains 12 pre-recorded titles for your use. Please see page 62 for further details.

Digital Still Camera

5

Press **RECORD** to capture image.

- As the image is processed, the status screens below appear. The next image may be captured after "COMPLETED" disappears.
- Depending on the image taken, the image page remaining indication may not change, or it may be decreased by 2 images.

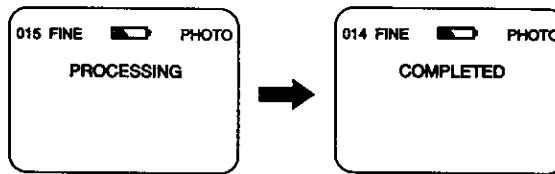
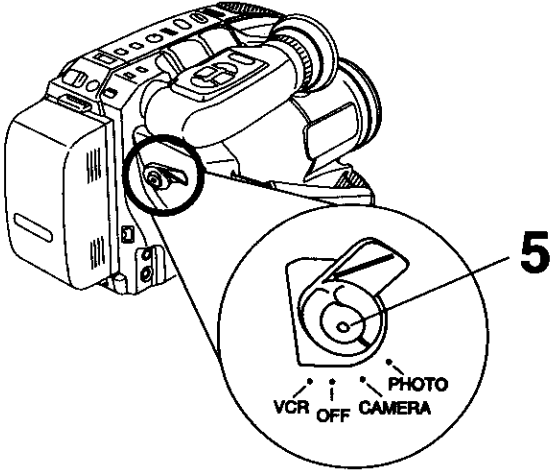

- For sharper images, set electronic shutter to higher speed when shooting in bright conditions, such as outdoors.

Note:

- If CompactFlash Card is not inserted, "NO CF CARD" appears on-screen. Set POWER to OFF, then insert the CompactFlash Card.
- If "CF CARD ERROR" appears on-screen, see page 80.
- Sound will not be recorded.
- The features below are not available while in PHOTO mode.
 - Auto Fade
 - Digital Fade
 - Color Digital Filter
 - Digital Zoom
 - Digital E.I.S.
 - Still/Strobe/Wide
 - Security Mode
 - Time Lapse
 - Message Mode
 - Intelligent Titler
 - Digital Wipe Mode
 - Picture in Picture Wipe Title

WARNING:

Do not, under any circumstances, remove the card immediately after pressing the RECORD/PAUSE (during recording of an image) or while deleting. This could damage the format of the card and make it unusable.

Special Features

Digital Still Camera

Using the Light

For capture of still images in dim lighting.

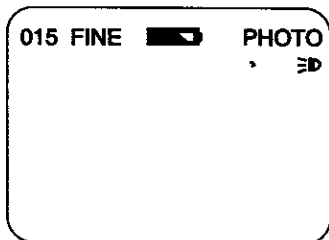
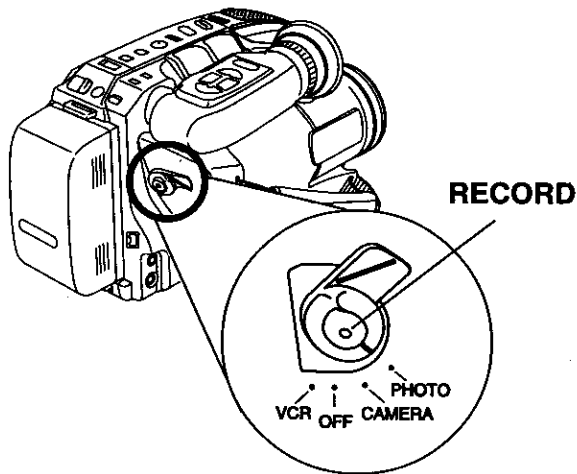
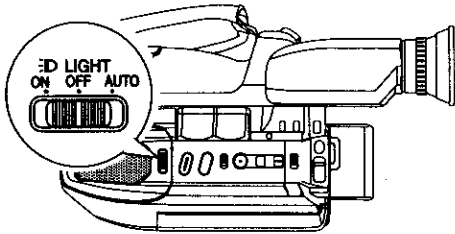

Before you begin...

- Connect Camcorder to power source.
- Insert the CompactFlash Card (page 51).
- Set POWER to PHOTO.

Set LIGHT to AUTO.

When **RECORD** is pressed to capture an image in dim lighting, the Light comes on for about 2 seconds, the image is captured, then goes out.

Or, set LIGHT to ON/OFF manually.

☞ appears in EVF when Light is on.

Caution:

Light becomes hot. Never cover Light while on.

Note:

- Using Light reduces battery operating time.
- Provide proper ventilation when using Light extensively in a hot environment.
- Using Light when the Camcorder is powered by a car battery may shorten bulb life.
- Set Light to OFF when not in use.

Digital Still Camera

Playback

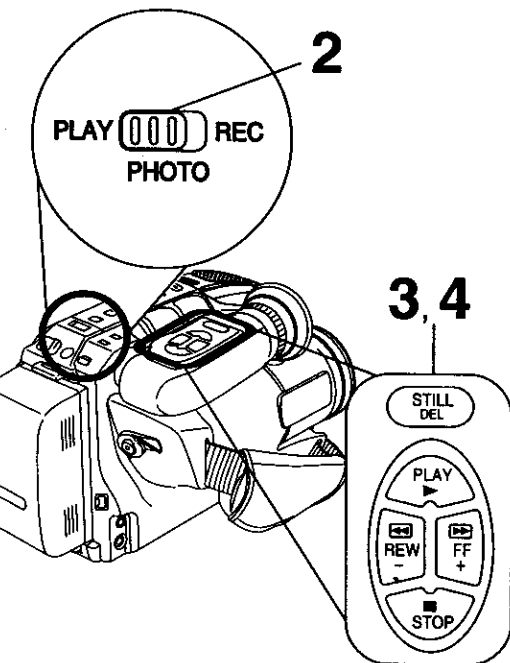
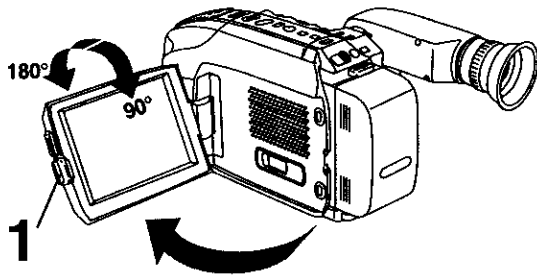

Note:

- If CompactFlash Card is not inserted, "NO CF CARD" appears on-screen. Set Power to OFF, then insert the CompactFlash Card.
- Pictures captured with other brand products cannot be used with this Camcorder.
- If "INCOMPATIBLE IMAGE" appears on-screen, the size of the captured image cannot be played back on this Camcorder.
- Do not change POWER setting to CAMERA or change recording mode while "PLEASE WAIT" is displayed.
- If "CF CARD ERROR" appears on-screen, see page 80.

Before you begin...

- Connect Camcorder to power source.
- Insert the CompactFlash Card (page 51).
- Set POWER to PHOTO.

1 Press **LCD-OPEN** and swing LCD monitor fully open. Adjust viewing angle.

2 Slide **PHOTO MODE** to **PLAY**. The Multi Image Playback screen appears. The last captured image screen is underlined.

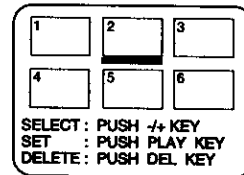

- If there are no recordings on the card, "NO PICTURE" appears on-screen.
- In NORMAL or FINE mode, the color of the Multi Image page number is as follows:
 NORMAL mode → green
 FINE mode → white

3 Press **+(FF)** → next.
 Press **-(REW)** → previous.
 • The selected image will be underlined in green.
 • Continue pressing + (FF) or - (REW) for next or previous page.

4 Press **PLAY** to display image. This screen appears followed by image.

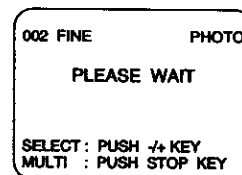

- Press DISPLAY to remove or redisplay this screen.
- Press STOP to redisplay Multi Image playback screen.

Special Features

Digital Still Camera

Deleting Specific Image Pages

Delete older images to make room for new ones.

Important :

Once deleted, images cannot be restored.

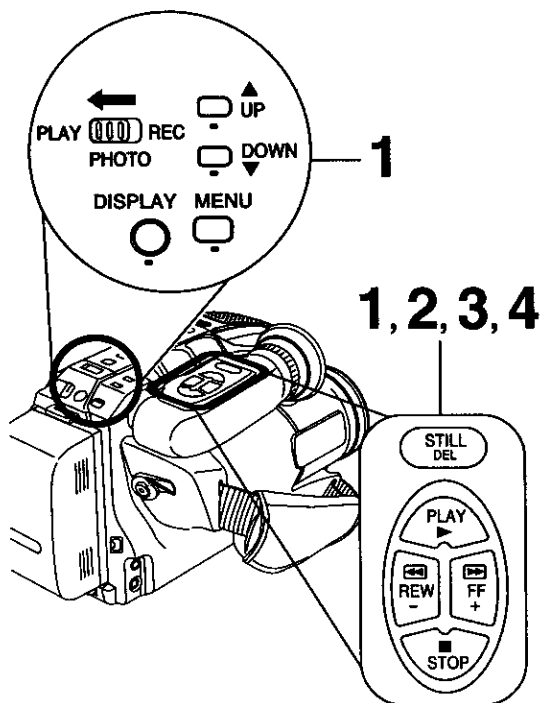

Before you begin...

- Connect Camcorder to power source.
- Insert the CompactFlash Card (page 51).
- Set POWER to PHOTO.
Slide PHOTO MODE to PLAY.

1 Press **DEL(STILL)** for **DELETE** menu. Press **UP ▲** or **DOWN ▼** to select **PAGE**.

- To exit menu at any time, press **STOP**.

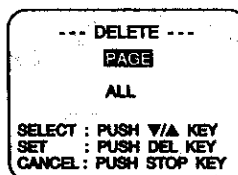

2 Press **DEL(STILL)** for Multi Image screen. Press **+ (FF)** or **- (REW)** to select image page. Press **PLAY** once to set. Or, press twice to undo.

- Press **+ (FF)** or **- (REW)** and **PLAY** repeatedly to select several pages at one time.
- The selected image will be underlined in green.
- You can delete set images underlined in red.

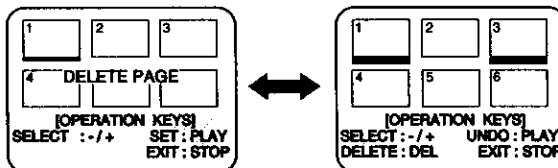

3 Press **DEL(STILL)**. This message appears.

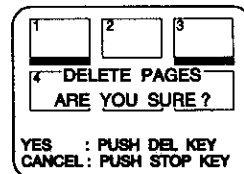

4 Press **DEL(STILL)** to delete the page.

- As image pages are deleted, page numbers adjust automatically.

Note:

- Pictures captured with other brand products cannot be used with this Camcorder.
- If "CF CARD ERROR" appears on-screen, see page 80.

WARNING:

Do not, under any circumstances, remove the card immediately after pressing the RECORD/PAUSE (during recording of an image) or while deleting. This could damage the format of the card and make it unusable.

Digital Still Camera

Deleting All Image Pages

All image pages are deleted from memory.

Important:

Once deleted, images cannot be restored.

Before you begin...

- Connect Camcorder to power source.
- Insert the CompactFlash Card (page 51).
- Set POWER to PHOTO.
- Slide PHOTO MODE to PLAY.

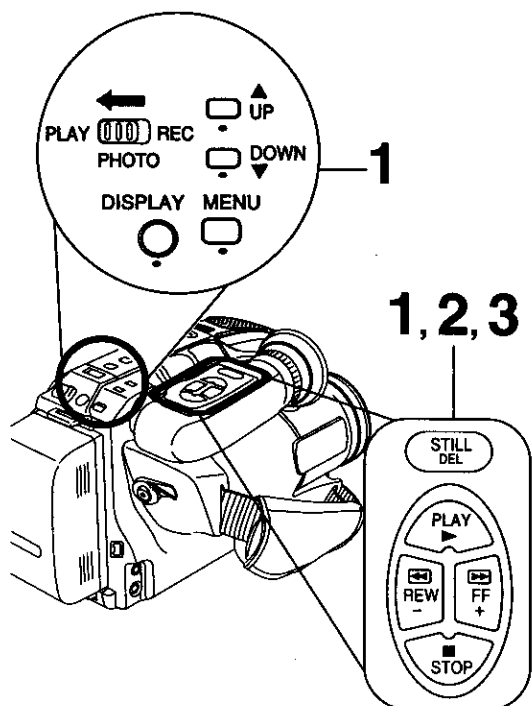

- 1** Press **DEL(STILL)** for **DELETE** menu. Press **UP ▲** or **DOWN ▼** to select **ALL**.

- To exit menu at any time, press **STOP**.

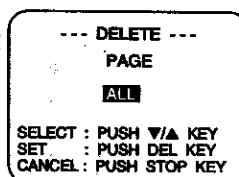

- 2** Press **DEL(STILL)**. This message appears.

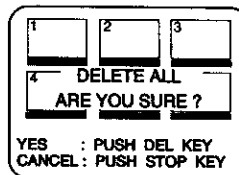

- 3** Press **DEL(STILL)** to delete all pages.
 - "NO PICTURE" appears on-screen after deletion.

Note:

- Pictures captured with other brand products cannot be used with this Camcorder.
- If "CF CARD ERROR" appears on-screen, see page 80.

WARNING:

Do not, under any circumstances, remove the card immediately after pressing the RECORD/PAUSE (during recording of an image) or while deleting. This could damage the format of the card and make it unusable.

Special Features

Digital Still Camera

Picture in Picture Wipe Title

Captured still images (pages 52, 53) can be recorded along with the current picture.

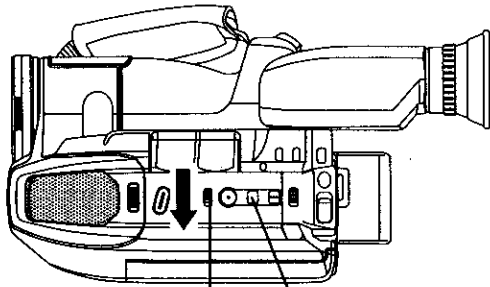

1 MODE

Still image

Moving Picture

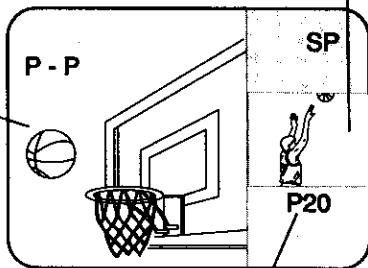

Multi image playback page number

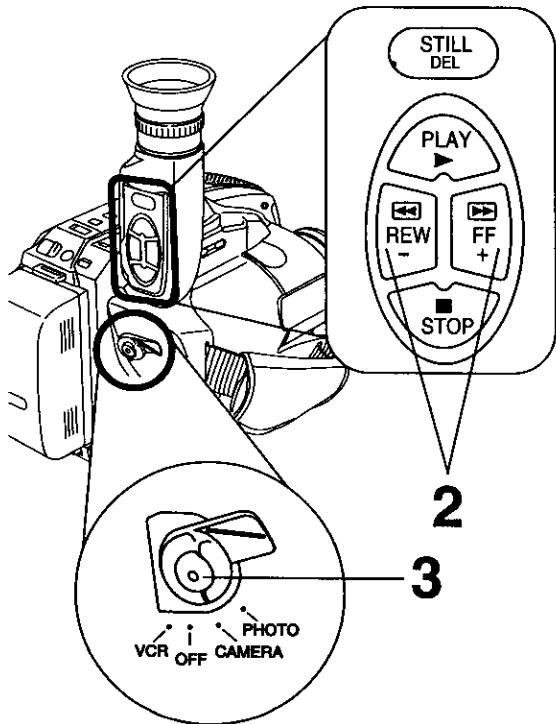

2

3

Before you begin...

- Connect Camcorder to power source.
- Insert the CompactFlash Card (page 51).
- Set POWER to CAMERA.

(P - P = Picture in Picture)

1

Set **DIGITAL SELECT** to **DIGITAL WIPE**.

- A still image captured on the CF card and the Multi image playback page number is displayed on the right side of the screen.
- If there are no recordings on the card, "NO PICTURE" appears on-screen.

2

Press **+** (FF) or **-** (REW) to select still image to be used.

3

Start recording (page 22).

- When recording starts, Multi image playback number disappears. Then the capture still images can be recorded along with the current picture.
- To exit from the Picture in Picture Wipe title mode, press **MODE** (page 59).

Note:

- If CompactFlash Card is not inserted, "NO CF CARD" appears on-screen. Set Power to OFF, then insert the CompactFlash Card.
- Pictures captured with other brand products cannot be used with this Camcorder.
- If "INCOMPATIBLE IMAGE" appears on-screen, the size of the captured image cannot be played back on this Camcorder.
- If "CF CARD ERROR" appears on-screen, see page 80.
- If Picture in Picture Wipe Title selected, the following functions are not available: Security mode, Auto Fade, Digital Fade, Digital Filter, Digital Zoom, Digital E.I.S., Still/Strobe/Wide.

Digital Still Camera

Digital Wipe Mode

Insert a Captured still image into the current recording, or vice versa, in one of three wipe effects.

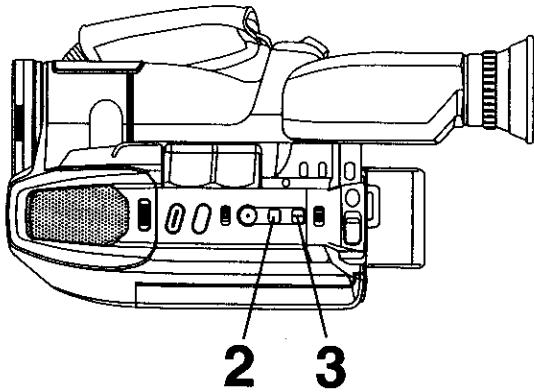

Before you begin...

- Connect Camcorder to power source.
- Insert the CompactFlash Card (page 51).
- Set POWER to CAMERA.

1 Repeat step 1 and 2 on page 58 to set Picture in Picture Wipe title.

2 Press **MODE** repeatedly for Wipe effect 1, 2, or 3 (See left).
 • WIPE 1 will flash for a while to store the image for the wipe.

3 Press **START**:
 once → inserts captured image.
 twice → inserts current recording picture.

- You can freeze the wipe in progress by pressing START. Press START again to resume wipe.

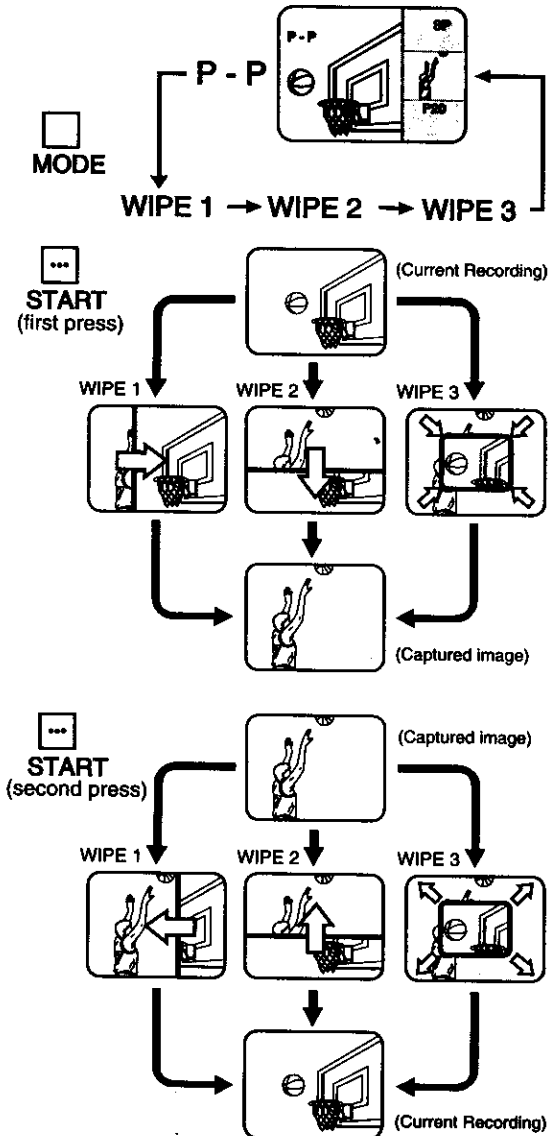

Note:

- If CompactFlash Card is not inserted, "NO CF CARD" appears on-screen. Set Power to OFF, then insert the CompactFlash Card.
- Pictures captured with other brand products cannot be used with this Camcorder.
- If "INCOMPATIBLE IMAGE" appears on-screen, the size of the captured image cannot be played back on this Camcorder.
- If "CF CARD ERROR" appears on-screen, see page 80.
- If Digital Wipe mode is selected, the following functions are not available: Security mode, Auto Fade, Digital Fade, Digital Filter, Digital Zoom, Digital E.I.S., Still/Strobe/Wide.

Special Features

Digital Still Camera

PhotoShot Title Library

The included 2MB CompactFlash Card already contains 12 pre-recorded titles. You can insert any one of the 12 included pre-recorded titles into your current video recording by following the steps outlined below.

CAUTION:

If you delete the following pre-recorded titles, they will not be restored.

Before you begin...

- Connect Camcorder to power source.
- Insert the CompactFlash Card (page 51).
- Set POWER to CAMERA.

- 1** Set DIGITAL SELECT to DIGITAL WIPE.
- 2** Press **+ (FF)** or **- (REW)** to select still image to be used. Please see page 58 for further details.
- 3** Start recording (page 22).

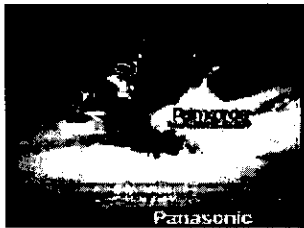

Panasonic



Anniversary



Happy Birthday



Bon Voyage

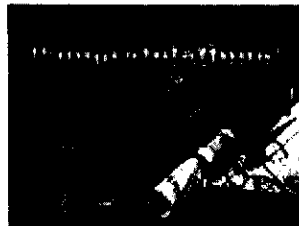

Congratulations

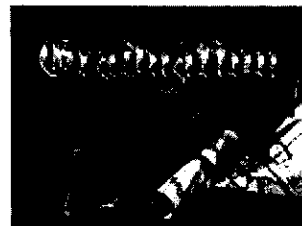

Graduation



It's a Girl!



It's a Boy!



Our Wedding



Surprise!

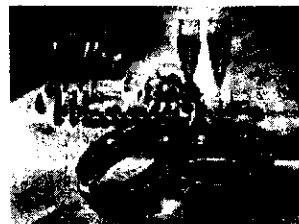

The Wedding



Vacation!

PC Connection

Digital PhotoShot Software

A live or captured image can be transferred to your PC (Personal Computer).

System Requirements for Digital PhotoShot

- IBM PC/AT or compatible.
- Microsoft Windows®95 or Windows®98.
- Intel® Pentium® Processor.
- RAM: 16 MB or more
- 2 MB of available hard-disk space.
- 256 color monitor (full color recommended).
- 3.5 inch 1.44 MB floppy disk drive (for installation).
- RS-232C serial port (D-Sub 9-pin). An adaptor (D-Sub 9-pin male to a D-Sub female) is required for a D-Sub 25-pin.
- Mouse or other pointing device.

PC-Camcorder Connection

Connect Camcorder PC jack to the serial port on your PC (Personal Computer) using the supplied PC connector cable. Refer to PC or Windows manual to identify which COM port to be used for connection.

Before you begin...

- Turn your PC off.
- Set Camcorder POWER to OFF.

Note:

- Be sure to turn PC off before connection for properly image transfer.
- After Camcorder and PC are connected by starting up the software included, video recording is not possible.

Special Features

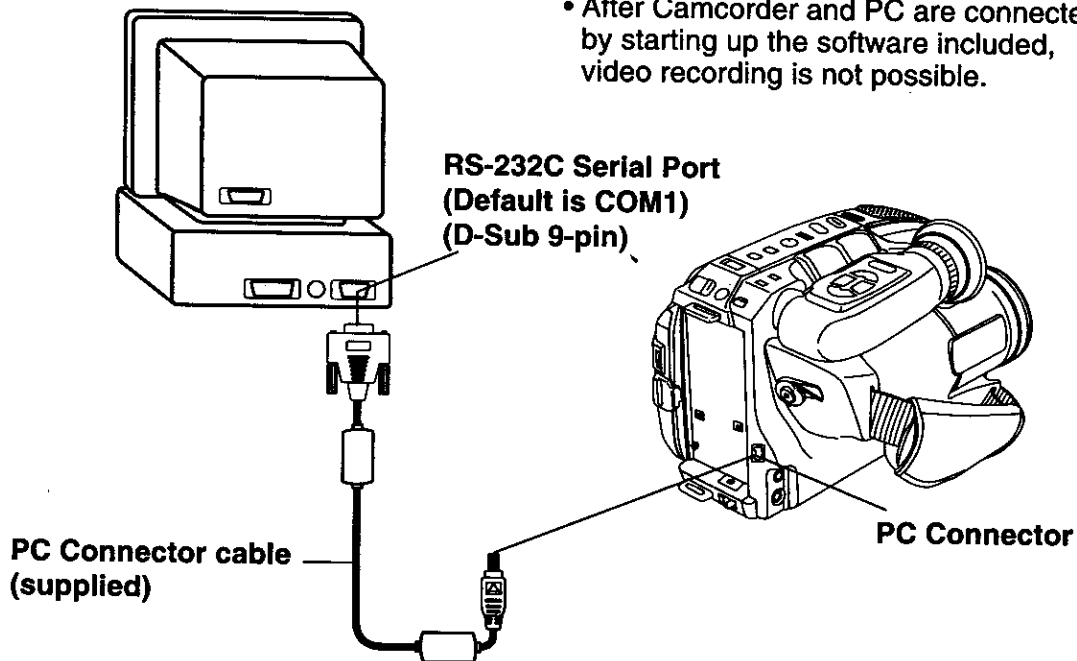

PC Connection

Software Installation (Windows 95/98)

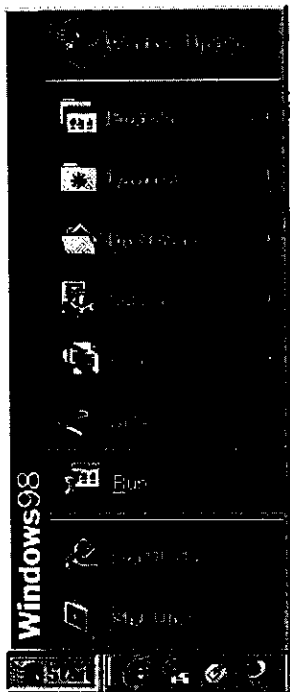

Before you begin...

- Your PC is in the power on mode.

- 1** Turn on PC (Personal Computer) and start up Windows.
- 2** Insert Digital PhotoShot disk (Windows 95/98) into a floppy disk drive.
- 3** Click on Start, then “Run...”
- 4** Type in `a:\setup.exe` and click OK.
 - If your 3.5 inch floppy disk drive is not “A”, use appropriate letter.
- 5** Follow instructions as they appear on PC screen until the installation is complete.
 - Setup window will disappear when the installation is complete.

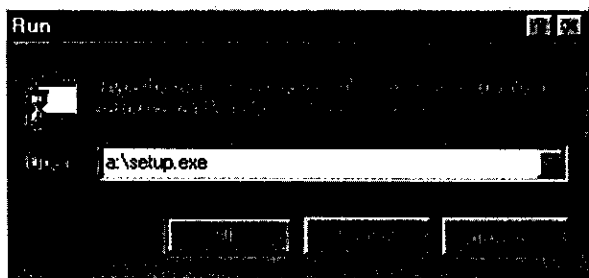

Note:

- Please look for Windows NT version of driver software on our website at <http://www.panasonic.com/video>.

PC Connection

Running the Software (Windows 95/98)

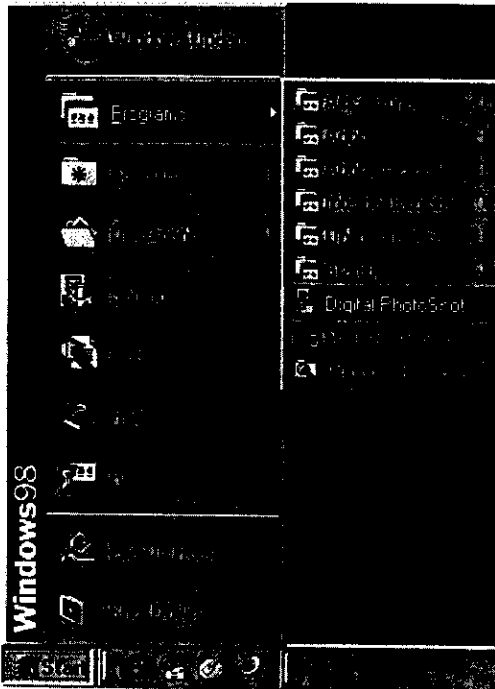

Before you begin...

- Insert the CompactFlash Card (page 51).
- Make Camcorder-PC connections (page 61).
- Turn both units on.
- Set Camcorder POWER to PHOTO.

1 Click on Start, then “**P**rograms,” then “**D**igital PhotoShot.”

2 “Digital PhotoShot” is opened.

Note:

- If connection error message appears, confirm COM Port to be used for the connection with the Camcorder and correct COM Port selection as follows:

- a Select File
- b Select COM setting
- c Select the correct COM Port
- d Select OK

COM PORT: COM1, COM2, COM3 or COM4
(COM1 or COM2 is usually used.)

Refer to Help for information about application operation and other Error messages.

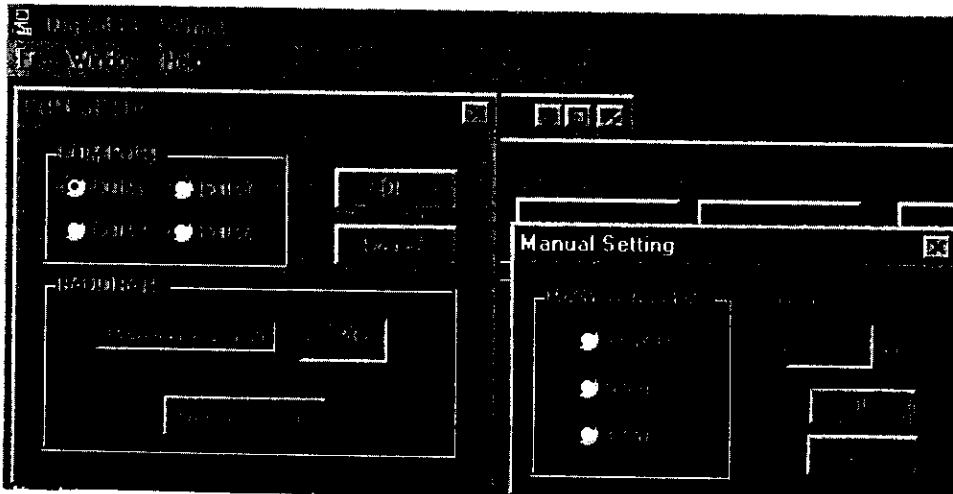
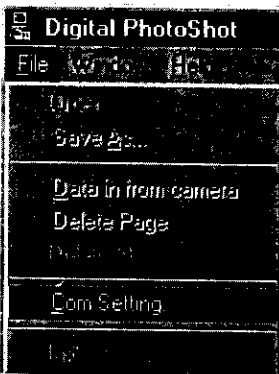

Special Features

PC Connection

Using Live Image Data

You can capture the current Camcorder picture to your PC.

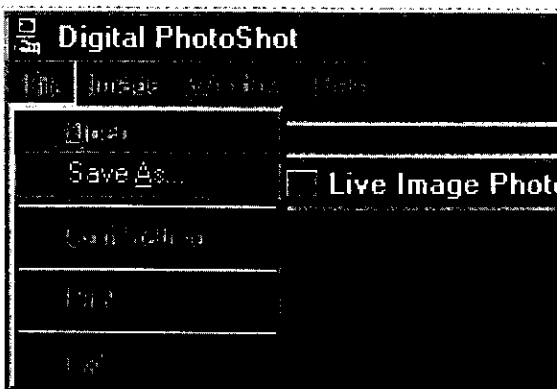
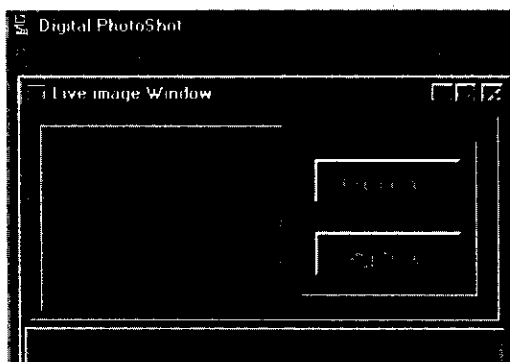
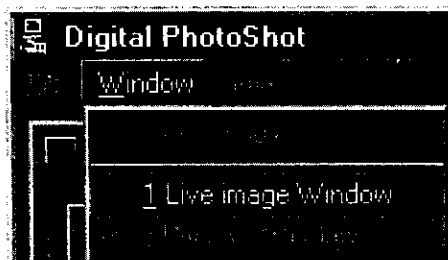

Before you begin...

- Insert the CompactFlash Card (page 51).
- Make Camcorder-PC connections (page 61).
- Turn both units on.
- Set Camcorder POWER to PHOTO.

1 Repeat step 1 and 2 on page 63 to run the Software.

2 Click on "**Window**," then select "**1 Live image Window**."

3 Click on "**Preview**," then Click on "**Capture**."

- Repeat this step to decide on an image.
- Captured image is transferred to your PC when "Capture" is clicked on.

4 Click on "**Window**," then select "**Live photo Zoom In**."

5 Click on "**File**," then select "**Save As**."
• Captured image is stored to your PC.

Note:

- If, while transferring the image to your PC, the displayed picture appears abnormal, restart the PC application and turn Camcorder POWER off, and then back on.

PC Connection

Using CF Card Image Data

Pictures captured with Camcorder can be transferred to your PC.

Before you begin...

- Insert the CompactFlash Card (page 51).
- Make Camcorder-PC connections (page 61).
- Turn both units on.
- Set Camcorder POWER to PHOTO.

1

Repeat step 1 and 2 on page 63 to run the Software.

2

“Preview Window” screen appears.

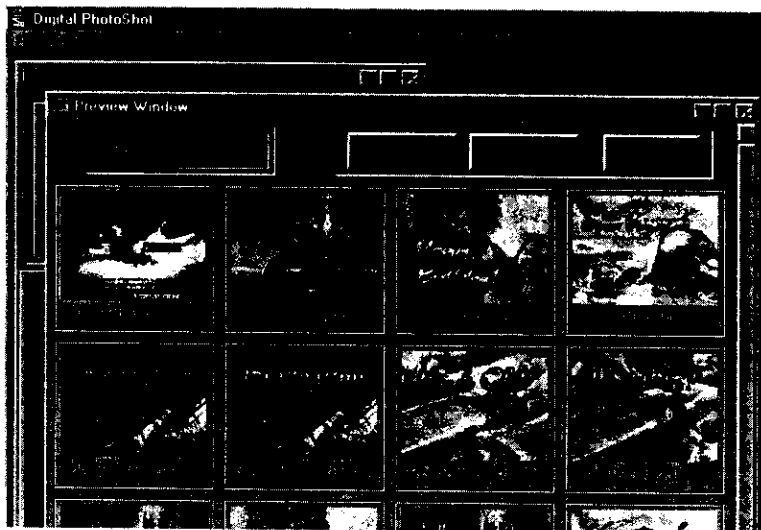

3

Select the image data you want to transfer to your PC.

- The selected image will be underlined in green.

4

Click on:

Transfer

- The picture image is transferred to your PC and displayed.

Delete

- The picture image is deleted.

Save...

- The picture image is transferred to your PC and displayed.
Save window appears.

Note:

- If, while transferring the image to your PC, the displayed picture appears abnormal, restart the PC application and turn Camcorder POWER off, and then back on.

PC Connection

Driver Quick Reference

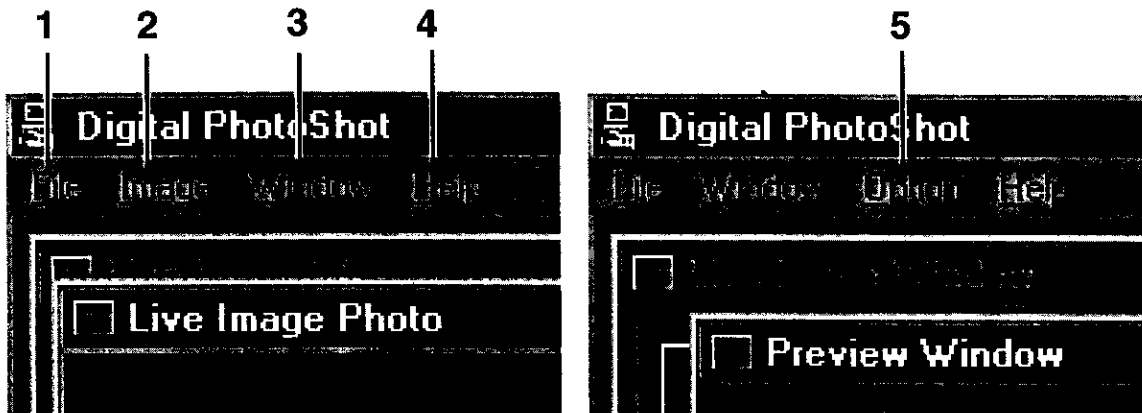

1 File

- **Open...**
To open an existing image (Bitmap or JPEG).
- **Save As**
To save the active image file under a new file name while preserving the original file.
- **Data in from CAMERA**
To display a dialog box listing all images in the CF Card memory along with Preview, Transfer, Delete, etc. commands.
- **Delete Page**
To delete the selected image from the CF Card memory.
- **Delete All**
To delete all images from the CF Card memory.
- **Com Setting**
To specify the port to which the Camcorder is connected.
- **Print...**
To print the currently active image.
- **Exit**
To quit the "Digital PhotoShot" application.

2 Image

- **Image Adjustment**
To modify the captured image as desired.
- **Copy to Clipboard**
To copy a view image to clipboard.

3 Window

- **Close Image**
Select "Close image" to close all view windows.
- **Live Photo Zoom In**
To open a view window.

4 Help

- **Help**
To display the Help screen.
- **About**
To display software version information.

5 Option

- **Reload**
To load the picture from the Camcorder to your PC again when Camcorder CF Card was changed.

Using a PCMCIA Adaptor (optional)

If your PC has a PCMCIA type II slot, you can insert the CompactFlash Card into a PCMCIA adaptor (optional, page 76) to transfer images, captured with this Camcorder only, to your PC.

Inserting a CompactFlash Card

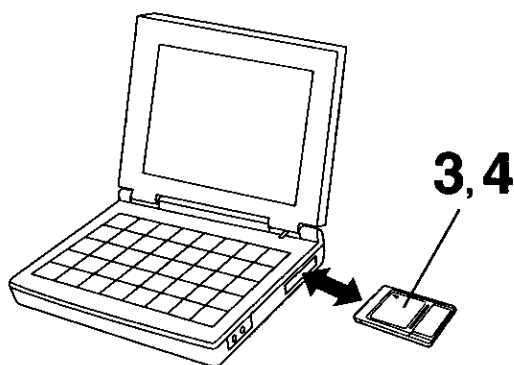
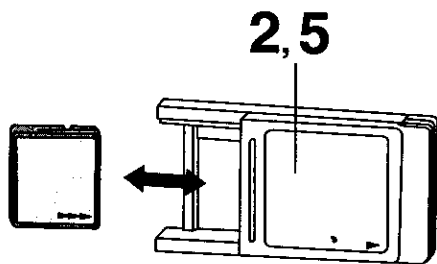
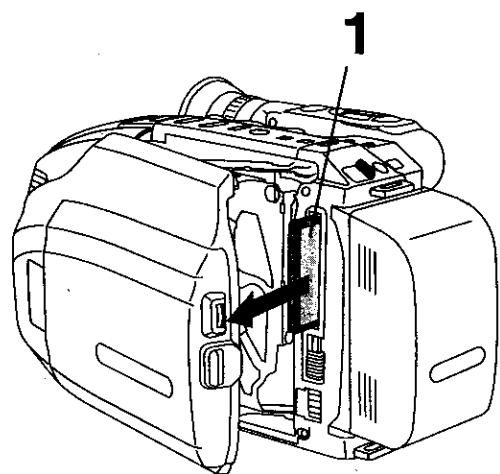

Before you begin...

- Turn your PC on.
- Set Camcorder POWER to OFF.

1

Remove the **CompactFlash Card** from the Camcorder (page 51).

2

Hold the **CompactFlash Card** so that the arrow side faces up and points toward the **PCMCIA Adaptor**. Securely insert the card into the PCMCIA Adaptor slot as far as it will go.

3

Hold the **PCMCIA Adaptor** so that the arrow side points toward the PCMCIA type II slot of **your PC (Personal Computer)**. Securely insert the PCMCIA Adaptor as far as it will go.

- Depending on the PC, it may be necessary to turn the PCMCIA Adaptor upside down in order to insert the card.

4

To remove, push the eject button on your PC (may vary by machine) and pull the **PCMCIA Adaptor** out until it is no longer inserted in the **PC (Personal Computer)**.

5

Pull the **CompactFlash Card** out of the **PCMCIA Adaptor**.

Note:

- Do not remove the PCMCIA Adaptor from the PC while the PC is working or while image data is being transferred between the CompactFlash Card and the PC (including operation such as opening and storing images), this will cause irreversible damage to the memory.
- If you change file name or folder in the CF card, the images be displayed properly on PHOTO mode.

Special Features

Viewfinder/LCD Monitor Indications

Tape remaining and battery charge level can be displayed.

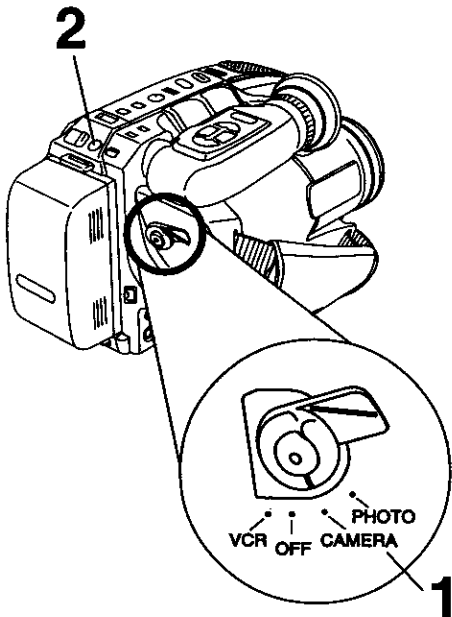

1 Set **POWER** to **CAMERA**.

2 Press **DISPLAY** repeatedly to select the following displays.

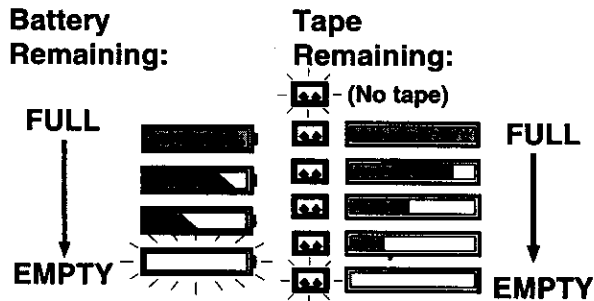
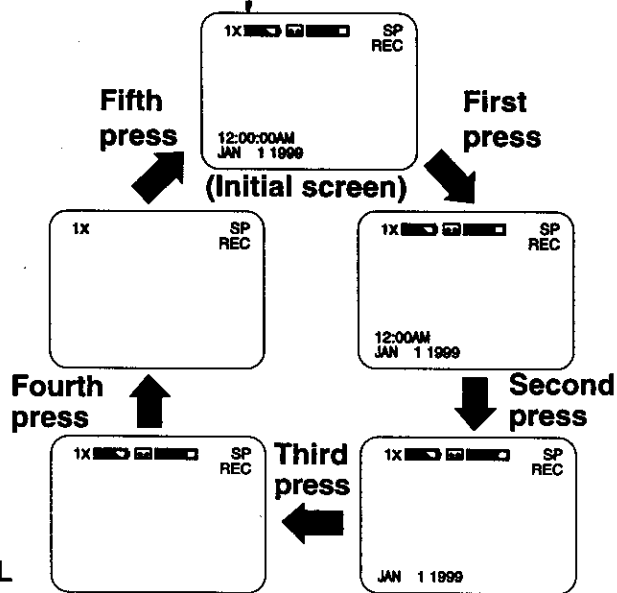

• Tape remaining indicator operates a few seconds after tape starts moving.

Recording the Date and Time

- 1** Do steps 1 and 2 above to select time/date, date only, or no display.
- 2** Start a recording (page 22).
 - Only the Date and/or Time are recorded.

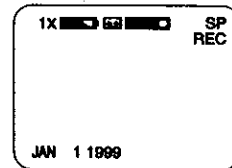
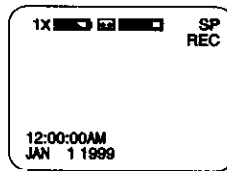

Display-Off Mode

No Indication, except Intelligent Titler (pages 48~50), will be displayed.

Press **DISPLAY** and **STOP** together over 1 second.

Press **DISPLAY** repeatedly to remove time/date.

Indications are restored when Camcorder is turned off, and then on again.

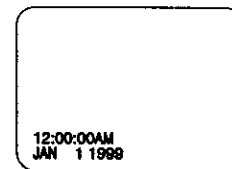

Viewfinder/LCD Monitor Indications

CAMERA/VCR mode

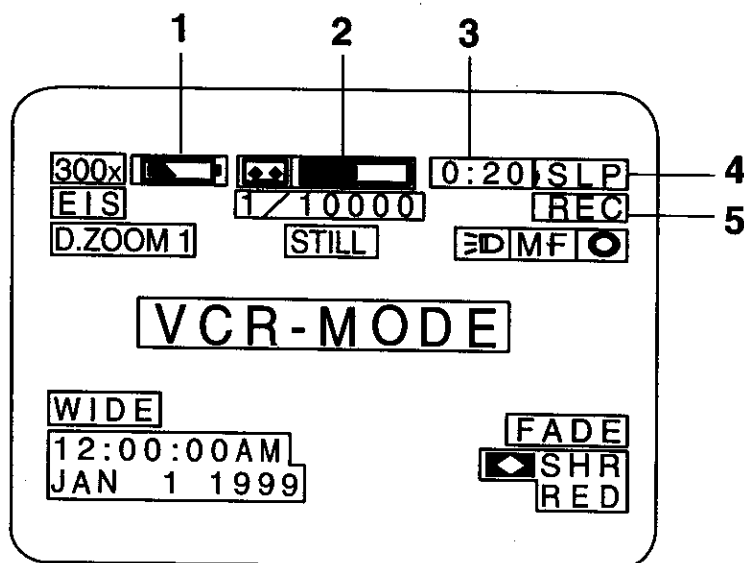

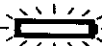
- 1 Battery Remaining**  (page 68)
 "WARNING LOW BATTERY" appears and External Power Lamp starts flashing 15 seconds before Camcorder shutoff.
- 2 Tape Remaining**
 - If cassette is not inserted or has no record tab in Camera (RECORD) mode, "1" flashes 1 minute and "CHECK TAPE" appears 5 seconds before Camcorder shutoff.
 - As end of tape is reached, "1" flashes and "TAPE END" appears 5 seconds.
- 3 10-Second Reminder**
 Each time a recording is started, a 10 second incremental display (up to 59:50) lets you monitor how long one scene is recorded.
- 4 TAPE SPEED** (pages 14, 22, 46)
 (SP=standard play, SLP=super long play, T.LAPSE=time lapse).
- 5 Operating Mode**
 REC (record)
 PAUSE
 FF (fast forward)
 PLAY
 REW (rewind)

0:00 0:10 0:20 59:50



(return to 0:00 and continue)

For more information
 visit us online at
 www.panasonic.com

Viewfinder/LCD Monitor Indications

CAMERA/VCR mode

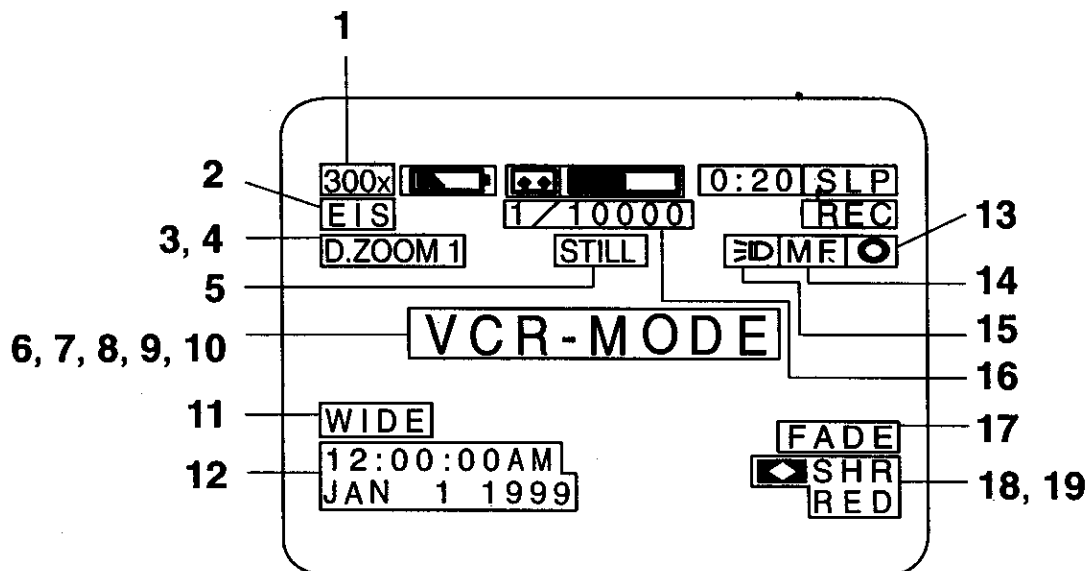

- | | |
|--|--|
| 1 Zoom Magnification level (page 33). | 13 Backlight (page 33). |
| 2 Digital E.I.S. (page 42). | 14 Manual Focus (page 34). |
| 3 Digital Zoom (page 41). | 15 Light ON/OFF (pages 21, 54). |
| 4 Digital Wipe (pages 58, 59). | 16 High Speed Shutter (page 35). |
| 5 Still/Strobe (page 43). | 17 Fade (page 37). |
| 6 VCR-MODE
Appears 1 minute when POWER is set to VCR or if RECORD/PAUSE is pressed in VCR mode. | 18 Color Digital Fade (pages 38, 39). |
| 7 DEW
If moisture condensation occurs in unit, "WARNING DEW DETECTED" appears, Power Lamp flashes, and Camcorder will shutoff in 15 seconds. Wait until lamp no longer flashes when Camcorder is turned on to use. | 19 Color Digital Filter (page 40). |
| 8 Time Lapse (page 46). | |
| 9 Security Mode (pages 44, 45). | |
| 10 Message Mode (page 47). | |
| 11 Wide Screen (page 43). | |
| 12 Date and Time (page 20). | |

Viewfinder/LCD Monitor Indications

PHOTO mode

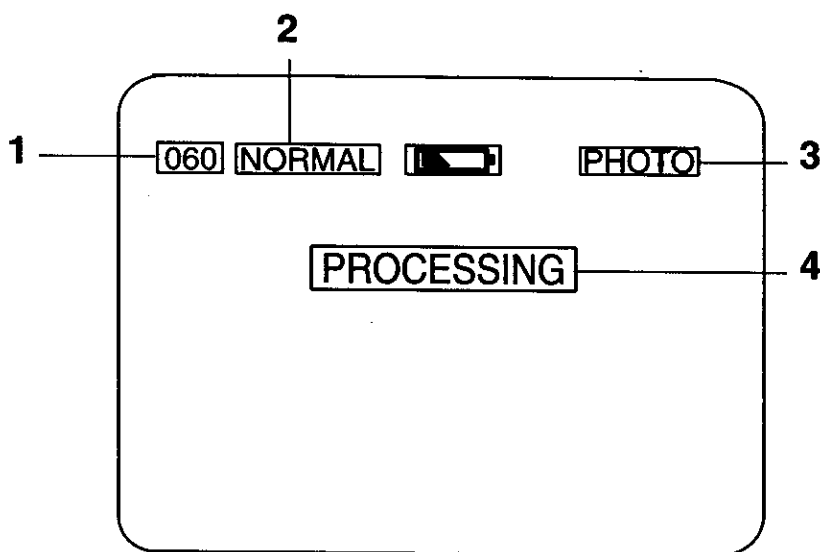

1 Image Page Remaining Indication (pages 52, 53)

- Image pages left in selected mode.
"000" flashes when memory is full.
- Memory capacity provided all pictures are taken in the same mode:
"NORMAL" mode → Approx 60 images
(Supplied 2 MB CompactFlash Card)
"FINE" mode → Approx 15 images
(Supplied 2 MB CompactFlash Card)

2 REC MODE

- NORMAL or FINE mode.
- Image Size :
"NORMAL" mode → 320 x 240 pixels.
"FINE" mode → 640 x 480 pixels.

3 Recording Mode

- POWER is set to PHOTO.

4 Image Status Indication

Image status is displayed when captured.

PROCESSING:

Image is being processed.

Note: Do not change setting to CAMERA or change recording mode while "PROCESSING" is displayed.

COMPLETED:

Image processing is completed.

The next image may be captured when "COMPLETED" disappears.

PLEASE WAIT:

Displayed when image is selected from Multi Image Playback screen.

Note: Do not change POWER setting to CAMERA or change recording mode while "PLEASE WAIT" is displayed.

Viewfinder/LCD Monitor Indications

PHOTO mode

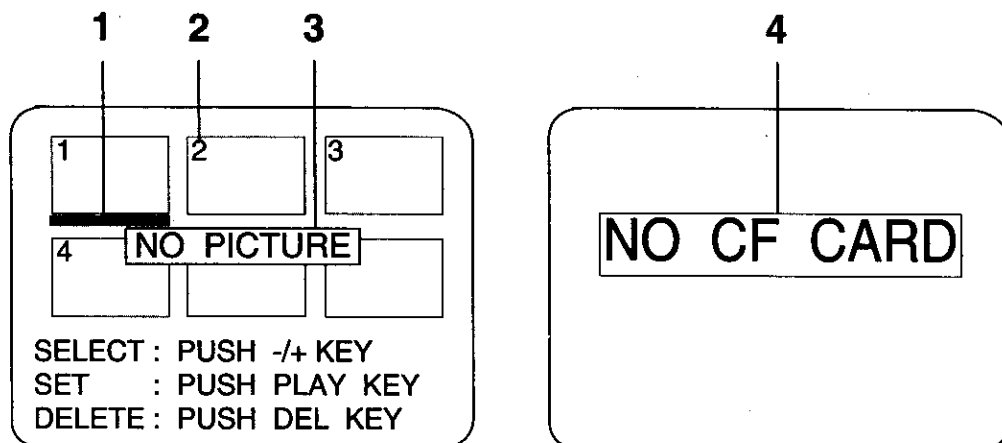

- 1** Currently selected image is underlined in green or red.
- 2** Multi Image Playback page number.
"NORMAL" mode → green
"FINE" mode → white
- 3** Image Status Indication
NO PICTURE:
No image is captured, all images are deleted from card.

- 4** **CF CARD Indication**
When the CompactFlash Card is not inserted in CAMERA or PHOTO mode, "NO CF CARD" appears.
If the CompactFlash Card is defective, "CF CARD ERROR" appears.

Operation Notes

Attaching Optional Filters and Lenses

When you remove the Lens Hood, pinch the Lens Hood and turn it counterclockwise as illustrated at right.

Then attach an optional filter or lens.

- Be careful not to touch the lens itself.
- Replace the Lens Hood after removing the accessory.

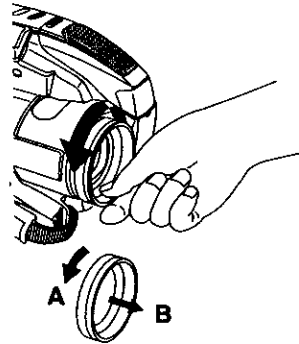

Lens Hood Area Operation Caution

With a Wide or Telephoto conversion lens (optional) attached, the four corners of the screen may darken when zoom is set to maximum wide angle.

When attaching the lens hood, a Wide or Telephoto conversion lens (optional), etc. after a filter (optional) has been attached, the four corners of the screen may darken when zoom is set to maximum wide angle.

With two filters (optional) attached, the four corners of the screen may darken when zoom is set to maximum wide-angle.

External MIC IN

Connect an external Microphone (optional) using an M3 connector if necessary. The built-in microphone is automatically disconnected when an external microphone is plugged in.

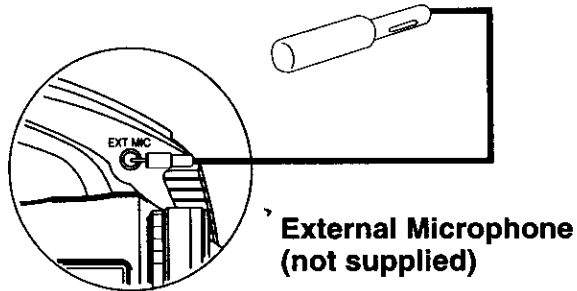

Cleaning EVF (Electronic Viewfinder)

To Remove

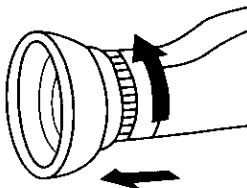

- 1** Turn the EVF Eyepiece counterclockwise 1/8 of a turn.
- 2** Pull free. Remove any lint or dust particles with a soft clean cloth being careful not to scratch the glass surfaces.
- 3** To re-install EVF
Line up the marks on the Eyepiece with the grooves inside the EVF shaft and attach. Turn the EVF clockwise 1/8 of a turn to lock in place.

Replacing Clock Battery

The clock battery is pre-installed. Follow the steps below if replacement becomes necessary.

WARNING:

Replace battery with Panasonic PART NO. VSBW0004 (CR2025) only. Use of another battery may present a risk of fire or explosion.

Caution: Battery may explode if mistreated. Dispose of used battery promptly. Keep away from children. Do not recharge, disassemble or dispose of in fire.

Clock Battery

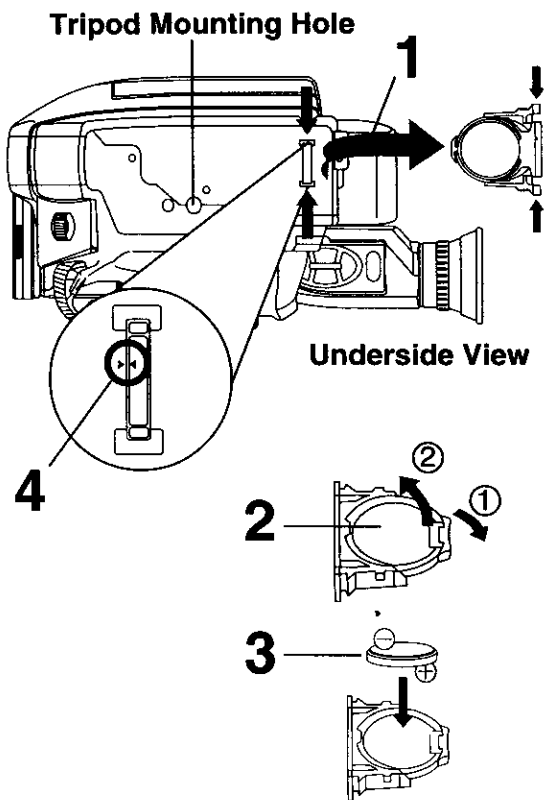

- 1** While pinching 2 tabs, pull Battery Tray out.
- 2** Bend 1 tab to remove Battery.
- 3** Snap new Battery (+ mark down) into Battery Tray.
 - Do not reverse the polarity.
- 4** Insert Battery Tray so the triangle marks meet.





Note:

- Keep Battery out of children's reach. Swallowing it may be harmful.
- Improperly installed, discharged, or missing battery causes "CLOCK BATTERY" to appear when DISPLAY is pressed.
- Battery life is approximately 5 years.

Palmcorder Accessory System

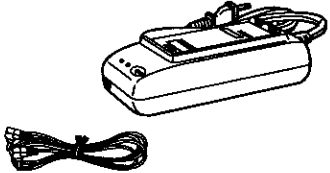
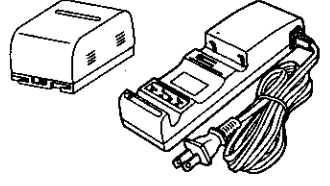

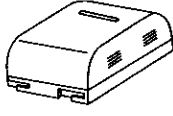
For ordering instructions, see the Accessory Order Form page.

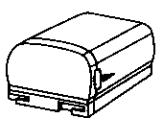
- The listed standard battery use times are based on continuous recording using this Palmcorder.

Accessory #	Figure	Description	Price
PV-A17		AC Adaptor with DC Power Cable	\$130.00
HHR-V214A/K		6.0Ah / 6 hr Battery Pack with Universal Battery Charger	\$200.00
P-V215A/1B		3.0Ah / 3 hr Battery Pack	\$60.00
PV-BP17, P-V214A/1B		2.4Ah / 2 hr 30 min Battery Pack	\$50.00
PV-BP18, P-V611A/1B		1.8Ah / 2 hr Battery Pack	\$45.00
PV-BP15, P-V213A/1B		1.2Ah / 1 hr 10 min Battery Pack	\$45.00
PV-AA6		"AA" Battery Case	\$20.00

Palmcorder Accessory System

For ordering instructions, see the Accessory Order Form page.

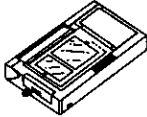
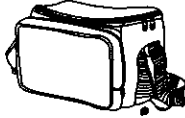
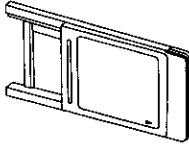
Accessory #	Figure	Description	Price
PV-C16		Car Battery Cord	\$70.00
PV-RF16		RF Adaptor	\$40.00
PV-P1		VHS PlayPak	\$35.00
PV-H18A		Soft Sided Carrying Case	\$49.00
KXL-D55		PCMCIA Adaptor	\$39.00

Palmcorder Accessory Order Form

Please photocopy this form when placing an order.

1. Palmcorder Model # _____

2. Items Ordered

Accessory #	Description	Price Each	Quantity	Total Price
Subtotal				
Your State & Local Sales Tax				
Shipping & Handling				5.00
Total Enclosed				

3. Method of payment (check one)

- Check or Money Order enclosed (NO C.O.D.SHIPMENTS)
- VISA Credit Card # _____
- MasterCard Expiration Date _____
- Discover Customer Signature _____

Make Check or Money Order to: MATSUSHITA ACCESSORIES

(Please do not send cash)

4. Shipping information (UPS delivery requires complete street address)

Ship To:

- Mr. _____
- Mrs. _____
- Ms. _____

First _____ Last _____ Phone #: _____
 Day () _____
 Street Address _____
 City _____ State _____ Zip _____ Night () _____

TO OBTAIN ANY OF OUR OMNIMOVIE/PALMCORDER ACCESSORIES YOU CAN DO ANY OF
 THE FOLLOWING:
 VISIT YOUR LOCAL PANASONIC DEALER
 OR
 CALL PANASONIC'S ACCESSORY ORDER LINE AT 1-800-332-5368
 [6 AM-5 PM M-F, 6 AM-10:30 AM SAT, PACIFIC TIME]
 OR
 MAIL THIS ORDER TO: PANASONIC SERVICES COMPANY ACCESSORY
 ORDER OFFICE
 20421 84th Avenue South Kent, WA. 98032

Specifications

Power Source:	Compact VHS Camcorder: DC 6V AC Adaptor: 110/120/220/240V AC, 50/60 Hz Battery: Nickel-Cadmium Type DC 6V
Power Consumption:	Compact VHS Camcorder: 6V DC 8.5 W (Max. 11.5 W) AC Adaptor: 24W 1.2W (when not in use.)
Video Signal:	EIA Standard (525 lines, 60 fields) NTSC color signal
Video Recording System:	4 rotary heads plus flying erase head. Helical scanning system
Audio:	1 track
Pick-Up System:	Sequential color difference field reverse system
Pick-Up Device:	One integral color filter Charge Coupled Device (CCD)
Lens:	26:1 zoom lens, F1:1.6 with auto iris control Focal length: 3.8mm - 98.8mm (4.5mm - 117mm: When recording.) (43.2mm - 1123.2mm: When converted to a 35mm still camera.) 4 speed power zoom function Lens filter diameter: 49mm
Viewfinder:	0.5 inch (12.7mm) Electronic Viewfinder
LCD Monitor:	4.0 inch (101.6mm) Liquid Crystal Display
Memory:	2 MB CompactFlash Card
Image Size:	FINE: 640 × 480 pixels Normal: 320 × 240 pixels
Image Storage:	FINE: Approx. 15 images Normal: Approx. 60 images
Image Format:	JPEG
Minimum Illumination Required:	2.0 lx (F1:1.6) 0.20 footcandles 10 lx (F1:1.6) 1.0 footcandles (EIA Standard)
Earphone Jack:	M3 Type
External Microphone Jack:	M3 Type
Operating Temperature:	32°F~104°F (0°C~40°C)
Operating Humidity:	10%~75%
Weight:	Compact VHS Camcorder: 2.4 lbs. 1.09 kg AC Adaptor: 0.77 lbs. 0.35 kg
Dimensions:	Compact VHS Camcorder: 4-1/4 (W) × 4-5/8 (H) × 7-1/8 (D) inch 107 (W) × 118 (H) × 180 (D) mm AC Adaptor: 2-3/4 (W) × 1-5/8 (H) × 5-3/4 (D) inch 70 (W) × 41 (H) × 145 (D) mm

Weight and dimensions shown are approximate.

Designs and specifications are subject to change without notice.

Before Requesting Service

If a problem arises, you may be able to correct it yourself.
See Symptom and Correction list below.

Symptom	Correction
No picture in EVF ...	<ul style="list-style-type: none"> • Connect Power Source. (pp. 11, 13) • Set POWER to VCR or CAMERA. (pp. 22, 27) • Check for Dew Indication. (p. 70) • Use fully charged Battery. (p. 13) • Firmly connect all needed cables. (p. 30)
The right side of the screen appears grayish...	<ul style="list-style-type: none"> • Be sure to slide Digital Select to Digital Wipe. (p. 58)
Video cassette cannot be inserted ...	<ul style="list-style-type: none"> • Connect Power Source. (pp. 11, 13) • Insert cassette, window side facing out. (p. 14)
Video cassette cannot be removed ...	<ul style="list-style-type: none"> • Connect Power Source. (pp. 11, 13)
Operation buttons do not work ...	<ul style="list-style-type: none"> • Check for Dew Indication. (p. 70)
Recording cannot be done ...	<ul style="list-style-type: none"> • Make sure record tab is intact. (p. 14) • Check Battery Indicator. (p. 68) • Check for Dew Indication. (p. 70)
Auto Focus does not operate ...	<ul style="list-style-type: none"> • Set FOCUS to AUTO. (p. 34) • Set POWER to CAMERA. (p. 22)
The Message mode cannot be used ...	<ul style="list-style-type: none"> • Make sure cassette is loaded. • Set MESSAGE to ON in Menu mode. (p. 47)
Sound from microphone can't be monitored ...	<ul style="list-style-type: none"> • Set unit to REC or Record/Pause mode.
Camera picture is too dark ...	<ul style="list-style-type: none"> • Turn HIGH SPEED SHUTTER off. (p. 35)
No playback picture, or the playback picture is noisy or contains streaks ...	<ul style="list-style-type: none"> • Press UP ▲/DOWN ▼ button during playback (Tracking Control). (p.29)
Playback picture is fast, and there is no sound ...	<ul style="list-style-type: none"> • Set TIME LAPSE to OFF in Menu mode. (p. 46)
"Panasonic ITS TAPES PLAY IN YOUR VCR ..." appears in EVF and LCD Monitor ...	<ul style="list-style-type: none"> • Set POWER to CAMERA, then hold down STOP over 5 seconds to exit Demo mode. (p. 8)
"NO CF CARD" appears in EVF and LCD Monitor ...	<ul style="list-style-type: none"> • Make sure CompactFlash Card is inserted. (p. 51)
Cannot capture the image ...	<ul style="list-style-type: none"> • Set POWER to PHOTO. (p. 52) • No memory remaining. Delete some images before capturing more images.
Cannot playback Still image ...	<ul style="list-style-type: none"> • Set POWER to PHOTO. (p. 52) • Make sure CompactFlash Card is inserted. (p. 51)
"NO PICTURE" appears in EVF and LCD Monitor ...	<ul style="list-style-type: none"> • There are no images in memory.
Top of playback picture waves back and forth excessively ...	<ul style="list-style-type: none"> • A playback signal is not as stable as an off the air TV signal, so the top of your TV screen may appear bent or unstable during playback. This is called, "Horizontal AFC time constant change." To correct, slowly turn the TV horizontal hold control. If you TV does not have this control, or adjusting it does not help, contact your TV service center. (Some nominal service charges may be required.)

Before Requesting Service

Video Head Cleaning



Clogged Video Head

While head cleaning is normally not needed, playing old or damaged tapes may clog the heads. When playback picture resembles example at the left, head cleaning is required.

Ideally, head cleaning should be performed by a qualified service technician. When this is not possible, purchase a head cleaning cassette. Be sure to follow cleaning cassette instructions exactly and only use when symptoms occur.

Self Diagnostic System

If any of the following numbers appear on-screen, the camcorder may have a problem. Do not remove the battery (if attached) and write down the displayed number on page 81. Then, take the camcorder to a service center for repair.

Error No.	Description
U11	CF Card Error
U12	CF Card Error
U13	CF Card Error
U14	CF Card/Camcorder Dialogue Error
U15	No CF Card Memory
U16	Captured image limit exceeded
U17	Captured image limit exceeded
U30	Error other than above

Request for Service Notice

Please photocopy this form when making a request for service notice.

Request for Service Notice:

In the unlikely event this product needs service.

- Please include your **proof of purchase**.
(Failure to do so will delay your repair.)
- To further speed your repair please provide an explanation of what is wrong with the unit and any symptom it is exhibiting.

Mail this completed form and your Proof of Purchase along with your unit to:
Panasonic Services Company
1705 N. Randall Road
Elgin, IL. 60123-7847
Attn: Camcorder Repair

Please write the displayed Self Diagnostic number here.
(See page 80)

Warranty

Panasonic Consumer Electronics Company, Division of Matsushita Electric Corporation of America
 One Panasonic Way Secaucus, New Jersey 07094

Panasonic Sales Company, Division of Matsushita Electric of Puerto Rico, Inc.
 Ave. 65 de Infantería. Km. 9.5
 San Gabriel Industrial Park, Carolina, Puerto Rico 00985

PANASONIC/QUASAR Video Products Limited Warranty

Panasonic Consumer Electronics Company or Panasonic Sales Company (collectively referred to as "the Warrantor") will repair this product with new or refurbished parts, free of charge, in the USA or Puerto Rico, in the event of a defect in materials or workmanship as follows (all time periods commence from the date of the original purchase):

PRODUCT	PARTS	LABOR
CAMCORDER	ONE (1) YEAR, EXCEPT CCD IMAGE SENSOR CCD IMAGE SENSOR - SIX (6) MONTHS	NINETY (90) DAYS NINETY (90) DAYS
VCR	ONE (1) YEAR	NINETY (90) DAYS
AV MIXER	ONE (1) YEAR	NINETY (90) DAYS
MONITOR-VCR	ONE (1) YEAR, EXCEPT CRT CRT - TWO (2) YEARS	NINETY (90) DAYS CRT- NINETY (90) DAYS CUSTOMER PAYS ALL LABOR CHARGES AFTER 90 DAYS

Monitor-VCR In-home or carry-in Service: 22" (diagonal) CRT / LCD and Larger
Monitor-VCR Carry-in Service: 21" (diagonal) CRT / LCD and smaller

Batteries (if included) - New rechargeable batteries in exchange for defective rechargeable batteries for ten (10) days. Non-rechargeable batteries are not warranted.

Tape (if included) - New video cassette tape in exchange for a defective video cassette tape for five (5) days.

In-home, carry-in or mail-in service, as applicable, in the USA can be obtained during the warranty period by contacting a Panasonic Services Company (PASC) Factory Servicenter listed in the Service Directory. Or call toll free 1-800-211-PANA(7262), to locate an authorized PASC Servicenter. Carry-in or mail-in service in Puerto Rico can be obtained during the warranty period by calling the Panasonic Sales Company telephone number listed in the Servicenter Directory.

This warranty is extended only to the original purchaser. A purchase receipt or other proof of the date of the original purchase is required before warranty service is rendered.

This warranty only covers failures due to defects in materials and workmanship which occur during normal use and does not cover normal maintenance, including, but not limited to, video and audio head cleaning. The warranty does not cover damage which occurs in shipment, or failures which are caused by products not supplied by the warrantor, or failures which result from accident, misuse, abuse, neglect, mishandling, misapplication, alteration, modification, faulty installation, set-up adjustments, improper antenna, inadequate signal pickup, maladjustment of consumer controls, improper operation, power line surge, improper voltage supply, lightning damage, commercial use such as hotel, office, restaurant, or other business or rental use of the product, or service by anyone other than a PASC Factory Servicenter or a PASC authorized Servicenter, or damage that is attributable to acts of God.

LIMITS AND EXCLUSIONS

There are no express warranties except as listed above. THE WARRANTOR SHALL NOT BE LIABLE FOR INCIDENTAL OR CONSEQUENTIAL DAMAGES (INCLUDING, WITHOUT LIMITATION, DAMAGE TO TAPES) RESULTING FROM THE USE OF THIS PRODUCTS, OR ARISING OUT OF ANY BREACH OF THE WARRANTY. ALL EXPRESS AND IMPLIED WARRANTIES, INCLUDING THE WARRANTIES OF MERCHANTABILITY AND FITNESS FOR PARTICULAR PURPOSE, ARE LIMITED TO THE APPLICABLE WARRANTY PERIOD SET FORTH ABOVE. Some states do not allow the exclusion or limitation of incidental or consequential damages, or limitations on how long an implied warranty lasts, so the above exclusions or limitations may not apply to you.

This warranty gives you specific legal rights and you may also have other rights which vary from state to state.

If a problem with this product develops during or after the warranty period, you may contact your dealer or Servicenter. If the problem is not handled to your satisfaction, then write to the Customer Satisfaction Center at the Panasonic Consumer Electronics Company address above.

SERVICE CALLS WHICH DO NOT INVOLVE DEFECTIVE MATERIALS OR WORKMANSHIP AS DETERMINED BY THE WARRANTOR, IN ITS SOLE DISCRETION, ARE NOT COVERED. COSTS OF SUCH SERVICE CALLS ARE THE RESPONSIBILITY OF THE PURCHASER.

warvid 10/20/97

Warranty

For Product Information, Operating Assistance, Literature Request, Dealer Locations, and all Customer Service inquiries please contact:

1-800-211-PANA(7262), Monday-Friday 9am-9pm Saturday-Sunday 9am-7am, EST.

Web Site: <http://www.panasonic.com>

You can purchase parts, accessories or locate your nearest servicenter by visiting our Web Site.

Accessory Purchases:

1-800-332-5368 (Customer Orders Only)

Panasonic Services Company 20421 84th Avenue South, Kent, WA 98032

(6 am to 5 pm Monday - Friday; 6 am to 10:30 am Saturday; PST)

(Visa, MasterCard, Discover Card, American Express, Check)

Product Repairs **Centralized Factory Servicenter**

MAIL TO : Panasonic Services Company
1705 N. Randall Road,
Elgin, IL 60123-7847

Attention: Camcorder Repair

Please carefully pack and ship, prepaid and insured, to the Elgin centralized repair Factory Servicenter. While there will be added handling delays, you may bring your unit to one of the following locations who will then forward the unit to Elgin for repair.

Customer's in Puerto Rico, please ship or carry in to location below ("Service in Puerto Rico").

Factory Servicenters Locations

CALIFORNIA

6550 Katella Avenue
Cypress, CA 90630

800 Dubuque Avenue
S. San Francisco
CA 94080

20201 Sherman Way
Suite 102
Canoga Park, CA 91306

3878 Ruffin Road
Suite A
San Diego, CA 92123

COLORADO

1640 South Abilene
Street Suite D
Aurora, CO 80012

FLORIDA

3700 North 29th Avenue
Suite 102
Hollywood, FL 33020

GEORGIA

8655 Roswell Road
Suite 100
Atlanta, GA 30350

ILLINOIS

9060 Golf Road
Niles, IL 60714

1703 North Randall Road
Elgin, IL 60123
(Pick-up/drop-off only)

MARYLAND

62 Mountain Road
Glen Burnie, MD 21061

MASSACHUSETTS

60 Glacier Drive
Suite G
Westwood, MA 02090

MICHIGAN

37048 Van Dyke Avenue
Sterling Heights,
MI 48312

MINNESOTA

7850-12th Avenue South
Airport Business Center
Bloomington, MN 55425

OHIO

2236 Waycross Road
Civic Center Plaza
ForestPark, OH 45240

PENNSYLVANIA

2221 Cabot Blvd. West
Suite B
Langhorne, PA 19047

Chartiers Valley
Shopping Center
1025 Washington Pike
Bridgeville, PA 15017

TENNESSEE

3800 Ezell Road
Suite 806
Nashville, TN 37211

TEXAS

7482 Harwin Drive
Houston, TX 77036

13615 Welch Road
Suite 101
Farmers Branch, TX
75244

WASHINGTON

20425-84th Avenue
South
Kent, WA 98032

HAWAII

99-859 Iwaiwa Street
Aiea, Hawaii 96701
Phone (808) 488-1996
Fax (808) 486-4369

Service in Puerto Rico

Matsushita Electric of Puerto Rico, Inc. Panasonic Sales Company/ Factory Servicenter:

Ave. 65 de Infantería. Km. 9.5 San Gabriel Industrial Park Carolina, Puerto Rico 00985

Phone (787) 750-4300 Fax (787) 768-2910

Index

Symbols

+ (FF) Button 55, 56, 58, 60
 - (REW) Button 55, 56, 58, 60

A

AC Adaptor 13
 Accessories (Optional) 75, 76
 Accessories (Supplied) 2
 Audio/Video Cable 30, 32
 Audio/Video Out 30, 32
 Auto Daylight Saving Time 19

B

Backlight 33
 BACKLIGHT Button 33
 Battery Pack 8, 11, 12
 BATTERY RELEASE Button 11
 BRIGHT Control 23, 27
 Built-In Twin Capsule 2-Way
 Microphone System 22

C

Camera Recording 22, 23, 24, 25, 26
 Car Battery Cord 13
 CARD EJECT Switch 51
 Charging Battery 11
 Clock Battery 74
 Clock Set 18, 19, 20
 Color Digital Filter 40
 CompactFlash Card 8, 51, 67
 Copying your Tapes 32

D

D.ZOOM Button 41
 DC IN 13
 DC Power Cable 13
 DEL(STILL) Button 56, 57
 Digital E.I.S. 42
 DIGITAL SELECT Switch
 37, 38, 40, 41, 42, 43, 44, 58, 60

Digital Still Camera

51, 52, 53, 54, 55, 56, 57, 58, 59, 60
 Digital Wipe Mode 59
 DISPLAY Button
 16, 18, 19, 20, 24, 26, 29, 36, 37, 38,
 39, 40, 44, 45, 46, 47, 48, 50, 52, 68
 Display-off Mode 68

E

EIS Button 42
 Electronic Viewfinder 73
 External MIC IN 73

F

Fade 37, 38, 39
 FADE Button 37, 39
 FAST FORWARD/SEARCH Button 29
 Focus 34

H

Hand Strap 15
 High Speed Shutter 35
 HIGH SPEED SHUTTER Button 35

L

LCD Monitor 23, 27, 52, 55
 LCD-OPEN Button 9, 10, 23, 27, 52, 55
 Lens Cover 22, 52
 Lens Hood 73
 Light 21, 54
 LIGHT Switch 21, 54

M

MANUAL FOCUS Wheel 34
 MENU Button
 16, 18, 19, 20, 24, 26, 36, 37, 38,
 39, 40, 44, 45, 46, 47, 48, 50, 52
 MENU Mode 16, 17
 Message Mode 47
 MODE Button 58, 59

Index

P

PC Connection 61, 62, 63, 64, 65, 66
PC Connector 61
PCMCIA Adaptor 67
PHONE (earphone) jack 23, 27
PHOTO MODE Selector 52, 55
PhotoShot Title Library 60
Picture in Picture Wipe Title 58
PLAY Button 10, 27, 28, 55
Playback 27, 28, 29, 30, 31
PlayPak 31
Power Lamp 69
Power Supply 11, 12, 13
POWER Switch 7, 9, 10, 22, 27, 52
POWER ZOOM Switch 33, 34
Programmed Recording 26

R

RECORD Button 53
RECORD/PAUSE Button 9, 22
Replacing Battery 74
Request for Service Notice 81
REWIND/SEARCH Button 10, 27, 29
RF Adaptor 30

S

Safety Precautions 3
Security Mode 44, 45
Self Demo Mode 7
Self Diagnostic System 80
Shoulder Strap 15
Slow Play (1/2) 28
Speaker 27
Specifications 78
START Button 59
Still / Strobe / Wide 43
STILL Button 29
Still Picture 29
STILL/STROBE Button 43
STOP Button 7, 10, 27

T

Tab 14
Tally Lamp 36
TAPE EJECT Switch 8, 14, 51
TAPE SPEED-Selector 14, 22
Time Lapse 46
TITLE Button 48, 49, 50
Titler 48, 49, 50
Tracking Control 29
Tripod Mounting Hole 74

U

UP ▲/DOWN ▼ Button 16, 29, 52

V

VHF Connecting Cable 30, 32
Video Cassettes (tapes) 14
Video Head Cleaning 80
Viewfinder/LCD Monitor Indications 68, 69, 70, 71, 72
Viewing 30
Vision Adjustment Control 22
VOLUME Control 27

W

Warranty 82, 83

Z

Zoom 33, 41