

SEARS

OWNERS MANUAL

**MODEL NO.
919.184160**

IMPORTANT:
Read the Safety Guidelines and
All Instructions Carefully Before
Operating.

CRAFTSMAN. SINGLE STAGE AIR COMPRESSOR

**ASSEMBLY
OPERATION
MAINTENANCE
REPAIR PARTS**

Record in the spaces provided.

- (1) The model number which can be found on the label on the front of the air tank saddle.
- (2) The code number which can be found on the foil label on the side of the air tank.
- (3) The Manufacturer's Number (ASME Code Compressors only) is located on the metal data plate which is welded onto the side of the air tank. (This data plate is painted the same color as the tank.)
- (4) The Motor Manufacturer's name which is located on the motor label.
- (5) The Motor Mfg. number - also located on the motor label.

Retain these numbers for future reference.

Model No. _____





Code No. _____

Sears, Roebuck and Co., Hoffman Estates, IL 60179 U.S.A.

TABLE OF CONTENTS

	Page
SAFETY GUIDELINES	2
WARNING CHART	3
SPECIFICATION CHART	5
GLOSSARY	5
ACCESSORIES FOR USE WITH SEARS AIR COMPRESSORS	5
GENERAL INFORMATION	6
DESCRIPTION OF OPERATION	6
INSTALLATION AND BREAK-IN PROCEDURES	6
Location of Air Compressor	6
Piping	7
Lubrication and Oil	7
Wiring Instructions	7
Wiring Diagram	7
Break-In Procedures	8
OPERATING PROCEDURES	8
MAINTENANCE	8
Air Compressor	8
Air Filter - Inspection and Replacement	8
Oil - Checking and Changing	9
Air Tank - Draining Water	9
Check Valve - Inspection and Replacement	9
Safety Valve Inspection	9
Motor	9
Belt - Replacement	9
Pulley and Flywheel - Alignment	10
TROUBLESHOOTING GUIDE	10
AIR COMPRESSOR DIAGRAM	12
Parts List	13
COMPRESSOR PUMP DIAGRAM	14
Parts List	15
HOW TO ORDER REPAIR PARTS	16
WARRANTY	16

SAFETY GUIDELINES - DEFINITIONS

<p>This manual contains information that is important for you to know and understand. This information relates to protecting YOUR SAFETY and PREVENTING EQUIPMENT PROBLEMS. To help you recognize this information, we use symbols to the right. Please read the manual and pay attention to these sections.</p>	 ▲ DANGER	 ▲ CAUTION
	<p>URGENT SAFETY INFORMATION - A HAZARD THAT WILL CAUSE SERIOUS INJURY OR LOSS OF LIFE.</p>	<p>Information for preventing damage to equipment.</p>
	 ▲ WARNING	 NOTE
	<p>IMPORTANT SAFETY INFORMATION - A HAZARD THAT <i>MIGHT</i> CAUSE SERIOUS INJURY OR LOSS OF LIFE.</p>	<p>Information that you should pay special attention to.</p>

IMPORTANT SAFETY INSTRUCTIONS



• **SAVE THESE INSTRUCTIONS** •







⚠ WARNING

IMPROPER OPERATION OR MAINTENANCE OF THIS PRODUCT COULD RESULT IN SERIOUS INJURY AND PROPERTY DAMAGE. READ AND UNDERSTAND ALL WARNINGS AND OPERATING INSTRUCTIONS BEFORE USING THIS EQUIPMENT.

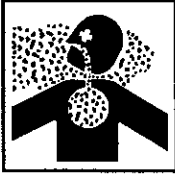

HAZARD	WHAT CAN HAPPEN	HOW TO PREVENT IT
<p>⚠ WARNING</p> <p>RISK OF BURSTING</p> 	<p>Air Tank</p> <ul style="list-style-type: none"> • THE FOLLOWING CONDITIONS COULD lead to a weakening of the tank, and RESULT IN A VIOLENT TANK EXPLOSION: <ol style="list-style-type: none"> 1. FAILURE TO PROPERLY DRAIN condensed WATER FROM THE TANK, causing rust and thinning of the tank steel. 2. MODIFICATIONS or attempted repairs TO THE TANK. 3. Unauthorized MODIFICATIONS TO THE PRESSURE SWITCH, SAFETY VALVE, OR any OTHER COMPONENTS WHICH CONTROL tank PRESSURE. <p>Attachments and Accessories</p> <ul style="list-style-type: none"> • EXCEEDING THE PRESSURE RATING OF AIR TOOLS, spray guns, air operated accessories, tires AND other INFLATABLES CAN CAUSE THEM TO EXPLODE or fly apart, and could result in serious injury. 	<ul style="list-style-type: none"> • DRAIN TANK DAILY OR AFTER EACH USE. If tank develops a leak, replace it immediately with a new tank or new compressor outfit. • NEVER drill into, weld, or MAKE ANY MODIFICATIONS TO THE TANK or its attachments. Never attempt to repair a damaged or leaking tank. Replace with a new tank. • The tank is designed to withstand specific operating pressures. NEVER MAKE ADJUSTMENTS OR PARTS SUBSTITUTIONS TO alter the FACTORY SET operating PRESSURES. • FOR essential CONTROL OF AIR PRESSURE, you must INSTALL A PRESSURE REGULATOR AND REGULATED AIR PRESSURE GAUGE to the air outlet of your compressor. • Follow the equipment manufacturers recommendation and never exceed the maximum allowable pressure rating of attachments. NEVER USE THE COMPRESSOR TO INFLATE SMALL LOW-PRESSURE OBJECTS SUCH AS CHILDREN'S TOYS, FOOTBALLS, BASKETBALLS, ETC.
<p>⚠ WARNING</p> <p>RISK OF ELECTRIC SHOCK</p> 	<ul style="list-style-type: none"> • Your AIR COMPRESSOR is powered by electricity. Like any other electrically powered device, IF it is NOT USED PROPERLY it MAY CAUSE ELECTRICAL SHOCK. • ELECTRICAL GROUNDING: FAILURE TO PROVIDE ADEQUATE GROUNDING TO THIS PRODUCT COULD RESULT IN SERIOUS INJURY OR DEATH FROM ELECTROCUTION. SEE GROUNDING INSTRUCTIONS 	<ul style="list-style-type: none"> • Any ELECTRICAL WIRING OR REPAIRS required to this product SHOULD BE PERFORMED BY QUALIFIED SERVICE PERSONNEL OR a LICENSED ELECTRICIAN, in accordance with national and local electrical codes. • MAKE CERTAIN that the ELECTRICAL CIRCUIT to which the compressor is connected PROVIDES PROPER ELECTRICAL GROUNDING, CORRECT VOLTAGE, AND ADEQUATE FUSE PROTECTION. • Never operate the compressor outdoors when it is raining.
<p>⚠ WARNING</p> <p>RISK OF EXPLOSION OR FIRE</p> 	<ul style="list-style-type: none"> • It is normal for ELECTRICAL CONTACTS within the motor and pressure switch to SPARK WHENEVER THE COMPRESSOR STARTS OR STOPS. 	<ul style="list-style-type: none"> • Always OPERATE the COMPRESSOR IN a well ventilated AREA FREE OF GASOLINE OR SOLVENT VAPORS. • If spraying flammable materials, LOCATE COMPRESSOR at least 20 FEET AWAY FROM SPRAY AREA. • STORE FLAMMABLE MATERIALS in a secure location AWAY FROM COMPRESSOR.

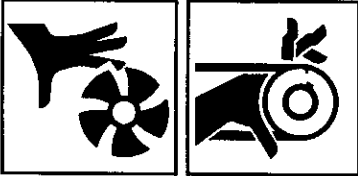
IMPORTANT SAFETY INSTRUCTIONS (cont'd)

HAZARD	WHAT CAN HAPPEN	HOW TO PREVENT IT
<p style="text-align: center;">⚠ WARNING</p> <p style="text-align: center;">RISK TO BREATHING</p> 	<ul style="list-style-type: none"> • The COMPRESSED AIR from your compressor IS NOT SAFE FOR BREATHING! The air stream may contain carbon monoxide or other toxic vapors, or particles from the tank or other components. • SPRAYED MATERIALS such as paint, paint solvents, paint remover, insecticides, weed killers, etc., CONTAIN HARMFUL VAPORS and poisons. 	<ul style="list-style-type: none"> • NEVER INHALE AIR FROM THE COMPRESSOR, either directly or from a breathing device connected to the compressor. WORK IN AN AREA equipped WITH GOOD CROSS-VENTILATION. • Read and FOLLOW THE SAFETY INSTRUCTIONS provided on the label or safety data sheet FOR THE MATERIAL YOU ARE SPRAYING. USE A NIOSH/MSHA APPROVED RESPIRATOR designed FOR use with YOUR specific APPLICATION.
<p style="text-align: center;">⚠ WARNING</p> <p style="text-align: center;">RISK FROM FLYING OBJECTS</p> 	<ul style="list-style-type: none"> • The COMPRESSED AIR STREAM CAN cause soft tissue damage, and can PROPEL dirt, chips, loose PARTICLES and small objects at high speed, resulting in property damage or personal injury. 	<ul style="list-style-type: none"> • ALWAYS WEAR ANSI Z87.1 APPROVED SAFETY GLASSES with side shields when using the compressor. • NEVER POINT any nozzle or SPRAYER toward any part of the body or AT OTHER PEOPLE or animals. • Always TURN the COMPRESSOR OFF AND BLEED PRESSURE from the air line BEFORE attempting maintenance, ATTACHING TOOLS or accessories.
<p style="text-align: center;">⚠ WARNING</p> <p style="text-align: center;">RISK FROM MOVING PARTS</p> 	<ul style="list-style-type: none"> • The COMPRESSOR CYCLES AUTOMATICALLY WHEN the PRESSURE SWITCH IS IN THE ON/AUTO POSITION! If you attempt repair or maintenance while the compressor is operating, or with the switch in the ON/AUTO position, you can expose yourself to moving parts. These MOVING PARTS CAN CAUSE SERIOUS INJURY or damage if they come into contact with you or your clothing. 	<ul style="list-style-type: none"> • Always UNPLUG the COMPRESSOR AND RELEASE AIR PRESSURE from the tank and any attachments BEFORE ATTEMPTING any MAINTENANCE OR REPAIR. • NEVER OPERATE the COMPRESSOR WITH GUARDS or covers which are damaged or REMOVED.
<p style="text-align: center;">⚠ WARNING</p> <p style="text-align: center;">RISK OF BURN</p> 	<ul style="list-style-type: none"> • Contact with HOT PARTS such as the compressor head or outlet tubes COULD RESULT IN A SERIOUS SKIN BURN. 	<ul style="list-style-type: none"> • NEVER TOUCH HOT COMPONENTS during or immediately after operation of the compressor. Do not reach around protective shrouds or attempt maintenance until unit has been allowed to cool.

SCOM1096

SPECIFICATION CHART

Model No.	919.184160
Horsepower	6.5 HP
Displacement CFM at Max. Pressure	15
Bore	2 7/8
Stroke	2"
Voltage - Single Phase	220
Minimum Branch Circuit Requirement	20 amp
*Fuse Type	Fusetron Type "T"
Amperage at Max. Pressure	15
Air Tank Capacity - Gallons	60 gal ASME
Approximate Cut-in Pressure	100
Approximate Cut-out Pressure	125
SCFM@ 90 psig	10.5
SCFM@ 40 psig	13.0
UL Listed	Yes

***A circuit breaker is preferred. Use only a fuse or circuit breaker that is the same rating as the branch circuit the air compressor is operated on.**

GLOSSARY

CFM: Cubic feet per minute.

SCFM: Standard cubic feet per minute; a unit of measure of air delivery.

PSIG: Pounds per square inch gauge; a unit of measure of pressure.

ASME: American Society of Mechanical Engineers; made, tested, inspected and registered to meet the standards of the ASME.

UL Listed: Underwriters Laboratories; samples of compressor outfits taken from production were submitted to UL and found to comply with their requirements for design and performance.

Cut-Out Pressure: When you turn on your air compressor and it begins to run, air pressure in the air tank begins to build. It builds to a certain high pressure before the motor automatically shuts off - protecting your air tank from pressure higher than its capacity. The high pressure at which the motor shuts off is called "cut-out pressure."

Cut-In Pressure: While the motor is off, air tank pressure drops as you continue to use your accessory. When the tank pressure drops to a certain low level the motor will re-start automatically. The low pressure at which the motor automatically re-starts is called "cut-in pressure."

To Lock-Out Power: Place a lock on the line power switch so no one else can turn on the power.

ACCESSORIES FOR USE WITH SEARS AIR COMPRESSORS

The following accessories are available through the current Power and Hand Tool Catalog or full-line Sears stores.

- SPRAY GUNS
- BLOW GUNS
- AIR CAULKING GUNS
- AIR POWERED WASHER GUNS
- SAND BLASTERS
- AIR BRUSHES
- IN LINE FILTERS
- TIRE AIR CHUCKS
- PAINT TANKS
- AIR TANKS
- INFLATOR KITS
- QUICK CONNECTOR SETS
(various sizes)
- AIR PRESSURE REGULATORS
- OIL FOG LUBRICATORS
- AIR TOOLS
 - Sanders
 - Drills
 - Impact Wrenches
 - Hammers
- AIR HOSE:
 - 1/4", 3/8" OR 1/2" I.D.
 - in various lengths

GENERAL INFORMATION

You have purchased an air compressor unit consisting of a two cylinder, single stage air compressor pump, an ASME air tank, associated controls and instruments. This air compressor must be permanently mounted in place.

Your air compressor can be used for operating paint spray guns, air tools, caulking guns, grease guns, air brushes, sandblasters, inflating tires and plastic toys,

spraying weed killers, insecticides, etc. An air pressure regulator is usually necessary for most of these applications. Regulators can be purchased from most Sears stores or through the current Sears Power and Hand Tool Catalog.

Separate air transformers which combine the functions of air regulation and/or moisture and dirt removal should be used where applicable.

Some form of piping or shut-off valve must be installed before operating the air compressor. A 1/2" NPT shut-off globe valve should be installed at the air compressor tank. Do not use a ball valve.

DESCRIPTION OF OPERATION

Air Compressor Pump: To compress air, the pistons move up and down in the cylinders. On the downstroke, air is drawn in through the air intake filter and then through the air intake valves. The exhaust valve remains closed. On the upstroke of the piston, air is compressed. The intake valves close and compressed air is forced out through the exhaust valves, through the outlet tube, through the check valve and into the air tank. Working air is not available until the compressor has raised air tank pressure above that required at the air outlet.

Check Valve: When the air compressor is operating, the check valve is "open," allowing compressed air to enter the air tank. When the air compressor reaches "cut-out" pressure, the check valve "closes," allowing air pressure to remain inside the air tank. If the air is not unloaded, the motor will try to start, but will be unable to. The check valve allows the motor to re-start freely.

Pressure Switch: The pressure switch automatically starts the motor when the air tank pressure drops below the factory set "cut-in" pressure. It stops the motor when the air tank pressure reaches the factory set "cut-out" pressure.

Pressure Release Valve: The pressure release valve is designed to automatically release compressed air from the compressor head and the outlet tube when the air compressor reaches "cut-out" pressure or is shut off. If the air is not released, the motor will try to start but will be unable to. The pressure release valve allows the motor to restart freely. When the motor stops running, air will be heard escaping for a few seconds. No air should be heard leaking when the motor is running.

Safety Valve: If the pressure switch does not shut off the air compressor at or near its cut-out pressure setting, the safety valve will protect against high pressure by "popping out" at its factory set pressure (slightly higher than the pressure switch cut-out setting).

INSTALLATION AND BREAK-IN PROCEDURES

Location of the Air Compressor

Operate the air compressor in a clean, dry and well ventilated area. The air intake filter must be kept clear of obstructions which could reduce air delivery of the air compressor. The air compressor should be located at least 12" away from walls or other obstructions that could interfere with the flow of air through the fan bladed flywheel. The air compressor crankcase and head are

designed with fins to provide proper cooling. If the humidity is high, a Sears air filter can be installed to remove excessive moisture.

The air compressor should be as near to air outlets as possible in order to avoid long pipe lines. Do not place the air compressor where heat is excessive.

INSTALLATION AND BREAK-IN PROCEDURES (Cont.)

⚠ WARNING

EXCESSIVE VIBRATION MAY WEAKEN THE AIR TANK AND CAUSE AN EXPLOSION. THE OUTFIT MUST BE MOUNTED AS DESCRIBED AND ILLUSTRATED BELOW.

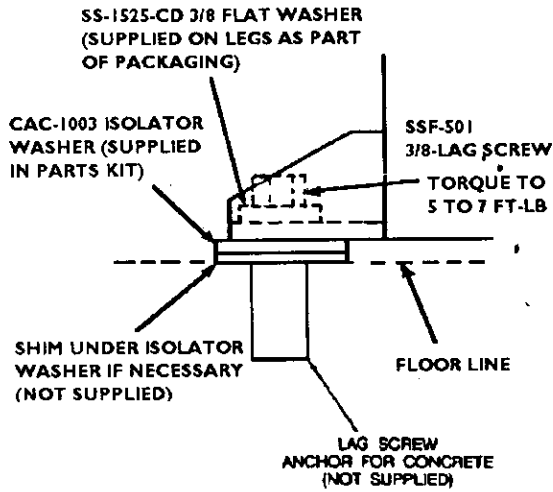

1. The air compressor must be bolted to the floor. Bolting holes are provided in the base feet.
2. Mount the air compressor on a solid level foundation with no strain to the air tank feet. Solid shims may be used if necessary.

Piping

⚠ CAUTION

Plastic or PVC pipe is not designed for use with compressed air. Regardless of its indicated pressure rating, plastic pipe can burst from air pressure. Use only metal pipe for air distribution lines.

If a pipe line is necessary, use pipe that is the same size as the air tank valve. Piping that is too small will restrict the flow of air. If piping is over 100 feet long, use the next larger size. Bury underground lines below the frost line and avoid pockets where condensation can gather and freeze. Apply pressure before underground lines are covered to make sure all pipe joints are free of leaks.

Lubrication and Oil

⚠ CAUTION

Compressors are shipped without oil. Do not attempt to operate this air compressor without first adding oil to the crankcase.

Place unit on a level surface. Remove oil fill plug and slowly add a special compressor oil such as Sears 9-16426 or SAE-20-20W SF motor oil until it is even with the top of the oil fill

hole. (It must not be allowed to be lower than 3/8" - 6 threads down - from the top.) When filling the crankcase, the oil flows very slowly. If the oil is added too quickly, it will overflow and appear to be full. (Crankcase oil capacity is 16 fluid ounces.) Under winter-type conditions use SAE 10W oil. (Multi-viscosity oil - 10W30 - will leave carbon deposits on critical components reducing performance and compressor life.) Replace oil fill plug.

Wiring Instructions

⚠ WARNING

IMPROPER GROUNDING CAN RESULT IN ELECTRICAL SHOCK. WIRING OF THE PRESSURE SWITCH, ELECTRIC MOTOR AND MANUAL ON/OFF SWITCH SHOULD BE DONE BY A LICENSED ELECTRICIAN IN ACCORDANCE WITH NATIONAL AND LOCAL CODES AND ORDINANCES.

To prevent added current draw and motor overheating we recommend the use of 12 gauge (AWG) wire, not exceeding a 70 foot length. The wire must be rated at a minimum temperature of 75° C.

When connecting wires, make sure that: (1) the electrical box is large enough; (2) service is of adequate amperage rating; (3) the supply line has the same electrical characteristics (voltage, cycles and phase) as the motor; (4) the line wire is the proper size and (5) no other equipment is operated from the same line. Various national and local codes and standards have been set up covering electrical apparatus and wiring. These should be consulted and observed. Our recommended wire sizes may be smaller than the minimum set up by local ordinances. If so, the larger size wire should be used to prevent excessive line voltage drop. For wiring instructions, see the diagram inside the pressure switch cover.

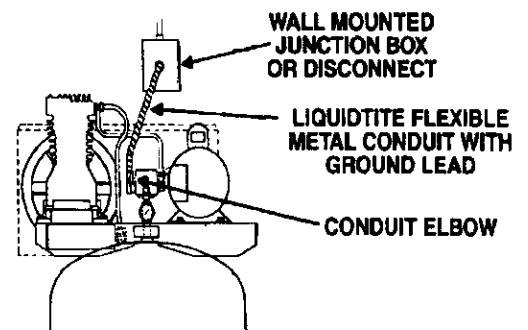

⚠ CAUTION

Electrical wiring must be located away from hot surfaces such as the compressor head, compressor cylinder or compressor outlet tube.

Break-In Procedures

⚠ CAUTION

Serious damage may result if the following break-in instructions are not closely followed.

This procedure is required only once; before the air compressor is put into service. Some form of piping or shut-off valve must be installed before beginning the break-in procedure. A 1/2" NPT shut-off globe valve should be installed at the air compressor tank. Do not use a ball valve.

1. Recheck compressor wiring. Make sure wires are secure at all terminal connections. Free all contacts of loose wire cuttings, etc.
2. Check oil level in the crankcase before operation. The oil level should be even with the top of the fill hole and must not be allowed to be lower than 3/8" (six threads down) from the top at any time. Add oil if level is low.

3. Open the shut-off valve fully, to permit air to escape and to prevent pressure build-up in the air tank.
4. Turn ON the air compressor.
5. Run the air compressor for 30 minutes to seal the rings and lubricate all internal surfaces.
6. Check all air line fittings and connections/piping for air leaks by applying a soap solution. Correct as necessary. Even minor leaks can cause this air compressor to overwork, resulting in premature break-down or inadequate performance.
7. Check for excessive vibration and noise. Adjust air compressor belt guard as necessary to eliminate chatter. Re-adjust or shim the air compressor feet, if necessary for proper level.
8. Close the shut-off valve and let the air compressor pump up to cut-out pressure. Turn the air compressor off and check oil level. Add oil if necessary. Connect the air hose to the air outlet adapter.

Your compressor is now ready for use.

OPERATING PROCEDURES

1. Before attaching an air hose or accessory, make sure the pressure switch OFF/AUTO lever is in the "OFF" position.
2. Attach hose and accessory.

⚠ WARNING

TOO MUCH AIR PRESSURE CAUSES A HAZARDOUS RISK OF BURSTING. CHECK THE MANUFACTURER'S MAXIMUM PRESSURE RATING FOR AIR TOOLS AND ACCESSORIES. THE REGULATOR OUTLET PRESSURE MUST NEVER EXCEED THE MAXIMUM PRESSURE RATING.

⚠ CAUTION

Compressed air from the outfit may contain water condensation and oil mist. Do not spray unfiltered air at an item that could be damaged. Some air operated tools or devices may require filtered air. Read the instructions for the air tool or device.

3. Turn the compressor on and allow tank pressure to build. The motor will stop when tank pressure reaches cut-out pressure.

Your outfit is ready for use.

MAINTENANCE

⚠ WARNING

UNIT CYCLES AUTOMATICALLY WHEN POWER IS ON. WHEN DOING MAINTENANCE, YOU MAY BE EXPOSED TO VOLTAGE SOURCES, COMPRESSED AIR OR MOVING PARTS. PERSONAL INJURIES CAN OCCUR. BEFORE PERFORMING MAINTENANCE OR REPAIR, TURN OFF AND LOCK OUT ELECTRIC POWER AND BLEED OFF AIR TANK PRESSURE. NEVER OPERATE THE COMPRESSOR WITH THE BELT GUARD REMOVED.

Air Compressor

A clean air compressor runs cooler and provides longer service. Clean or blow off fins and any other parts of the air compressor that collect dust or dirt. Do not place rags, containers or other material on or against the ventilation openings in the belt guard. Adequate ventilation is necessary to maintain proper air compressor operating temperature.

Air Filter - Inspection and Replacement

NOTE

Keep the air filter clean at all times. Do not operate the compressor with the air filter removed.

A dirty air filter will not allow the compressor to operate at full capacity. Before you use the compressor, check the air filter to be sure it is clean.

If it is dirty, remove the screws and filter retainer. Pull out the filter, replace with new.

Oil - Checking and Changing

⚠ CAUTION

Overfilling with oil will cause premature compressor failure. Do not overfill.

Check oil level in the crankcase daily. The oil level should be even with the top of the fill hole and must not be allowed to be lower than 3/8" from the top (6 threads) at any time. It is recommended that the oil be changed after every 100 hours of operation. To drain the oil, remove the oil drain plug and collect the oil in a suitable container. Be sure to replace the plug securely before adding new oil. Use a special compressor oil such as Sears 9-16426 or SAE-20-20W SF motor oil. (Crankcase oil capacity is 16 fluid ounces.) Under extreme winter conditions use 10 weight oil.

Air Tank - Draining Water

⚠ WARNING

WATER WILL CONDENSE IN THE AIR TANK. IF NOT DRAINED, THE WATER WILL CORRODE AND WEAKEN THE AIR TANK CAUSING A RISK OF AIR TANK RUPTURE.

Water should be drained from the air tank after each use. Operate the unit to apply 15-20PSIG and open the drain cock. Continue operating unit until all moisture is removed from the air tank. Close the drain cock tightly.

NOTE

If drain cock valve is clogged, release air pressure in air tank. The drain cock valve can then be removed, cleaned and reinstalled.

Check Valve - Inspection and Replacement

Remove the check valve for inspection or replacement if air tank pressure will not build up. Use the following procedure to inspect, clean or replace the check valve.

1. Release air pressure from the air tank.
2. Loosen the top and bottom nuts and remove the outlet tube.
3. Unscrew the check valve (turn counterclockwise) using a 7/8" diameter 1/2" socket wrench.
4. Check that the valve disc moves freely inside the check valve and that the spring holds the disc in the upper, closed position. The check valve may be cleaned with a solvent.

5. Apply sealant to the check valve threads. Reinstall the check valve (turn clockwise). The valve stem should still move freely - do not over tighten.
6. Replace the outlet tube and tighten top and bottom nuts.

Safety Valve - Inspection

⚠ WARNING

IF THE SAFETY VALVE DOES NOT WORK PROPERLY OVER-PRESSURIZATION MAY OCCUR, CAUSING AIR TANK RUPTURE OR EXPLOSION. OCCASIONALLY PULL THE RING ON THE SAFETY VALVE TO MAKE SURE THAT THE SAFETY VALVE OPERATES FREELY. IF THE VALVE IS STUCK OR DOES NOT OPERATE SMOOTHLY, IT MUST BE REPLACED WITH THE SAME TYPE OF VALVE.

Motor

The motor has a thermal overload protector. If the motor overheats for any reason, the overload protector will shut off the motor. The motor must be allowed to cool down before restarting. De-energize power supply. To restart, depress the reset button located on the end of the motor and energize the power supply.

NOTE

If the overload protector shuts the motor off frequently, check for a possible voltage problem. Low voltage can also be suspected when:

1. the motor does not get up to full power or speed;
2. fuses blow out when the motor is started;
3. lights dim when motor is started and remain dim while it is running.

Belt - Replacement

⚠ WARNING

SERIOUS INJURY OR DAMAGE MAY OCCUR IF PARTS OF THE BODY OR LOOSE ITEMS GET CAUGHT IN MOVING PARTS. NEVER OPERATE THE COMPRESSOR WITH THE BELT GUARD REMOVED. THE BELT GUARD SHOULD BE REMOVED ONLY WHEN THE POWER TO THE COMPRESSOR IS DISCONNECTED.

The motor is mounted on an adjustable motor base.

To replace belt:

1. Turn off and lock out power source.
2. Remove screws from the back of the belt guard.
3. Loosen the four motor mounting screws.
4. Slide the motor toward the compressor pump.
5. Remove belt and replace.

NOTE

The belt should be centered over the grooves on the flywheel and motor pulley.

6. Push the motor back into regular position and tighten bolts securely. Proper tension is approximately 1/4" belt deflection measured midway between the pulley and flywheel when a 3 pound weight or equivalent finger pressure is applied at this point. A loose belt will squeal at compressor start-up.
7. Replace beltguard and screws.

Pulley and Flywheel - Alignment

The compressor flywheel and motor pulley must be inline (in the same plane) within 1/16" to assure belt retention within sheave grooves. The motor mounting holes on the saddle are skewed to square the motor with the compressor mounting hole as the belt is tensioned. To check alignment, disconnect electrical power and remove the belt guard. Place a straightedge against the outside of the flywheel and measure the distance from it to the nearest groove. Alignment is achieved when the other end of the straightedge is within 1/16" of the measured dimension at the pulley grooves. Squareness is achieved when the pulley grooves are an equal distance from the straightedge on both sides of the motor shaft.

TROUBLESHOOTING GUIDE**⚠ WARNING**

UNIT CYCLES AUTOMATICALLY WHEN POWER IS ON. WHEN DOING MAINTENANCE, YOU MAY BE EXPOSED TO VOLTAGE SOURCES, COMPRESSED AIR OR MOVING PARTS. PERSONAL INJURIES CAN OCCUR. BEFORE PERFORMING MAINTENANCE OR REPAIR, TURN OFF AND LOCK OUT ELECTRIC POWER AND BLEED OFF AIR TANK PRESSURE. NEVER OPERATE THE COMPRESSOR WITH THE BELT GUARD REMOVED.

PROBLEM	CAUSE	CORRECTION
Excessive tank pressure - safety valve pops off.	Pressure switch does not shut off motor when compressor reaches "cut-out" pressure.	Pressure switch must be replaced.
Air leaks at fittings or hose.	Tube or hose fittings are not tight enough.	Tighten fittings where air can be heard escaping. Check fittings under soapy water solution. DO NOT OVER-TIGHTEN.
Air leaks at check valve.	Defective or dirty check valve.	Remove and clean or replace check valve. DO NOT OVER-TIGHTEN.
Air leaks at pressure switch release valve.	Defective pressure switch release valve.	Remove and replace the release valve.
Air leaks at air tank welds.	Defective air tank.	Air tank must be replaced. ⚠ WARNING DO NOT DRILL INTO, WELD OR OTHERWISE MODIFY AIR TANK. IT WILL BE WEAKENED.
Air leak from safety valve.	Possible defect in safety valve. Restricted check valve. Loose pulley. Low oil level. Loose flywheel. Loose compressor bolts. Loose belt. Carbon build-up.	Operate safety valve manually by pulling on ring. If valve still leaks, it should be replaced. Remove and clean or replace. Tighten pulley set screw. Maintain prescribed oil level. Tighten screw. Check bolts. Tighten as required. Tighten belt as per instructions under Belt Replacement above. Remove the head and valve plate. Clean the valve plate and the top of the piston. (Be sure carbon does not fall into the cylinder.) Reassemble to 25-30 ft.lbs. using new gasket and torque screws.

TROUBLESHOOTING GUIDE (Cont'd.)

PROBLEM	CAUSE	CORRECTION
Motor will not run.	<p>Motor overload protection switch has tripped.</p> <p>Tank pressure exceeds pressure switch "cut-in" pressure.</p> <p>Check valve stuck - fails to relieve head pressure; motor cannot start.</p> <p>Loose electrical connections.</p> <p>Possible defective capacitor.</p> <p>Possible defective motor.</p> <p>Fuse blown, circuit breaker tripped.</p> <p>Pressure release valve on pressure switch has not unloaded head pressure.</p>	<p>Let the motor cool off and reset switch by pressing the red button located on the end of the motor.</p> <p>Motor will start automatically when tank pressure drops below "cut-in" pressure of pressure switch.</p> <p>Remove and clean or replace. (Do not overtighten.)</p> <p>Check wiring connection inside pressure switch and terminal box area.</p> <p>Return to Sears Service Center for inspection or replacement if necessary.</p> <p>Have checked at a local Sears Service Center.</p> <ol style="list-style-type: none"> 1. Check fuse box for blown fuse and replace if necessary. Re-set circuit breaker. Do not use a fuse or circuit breaker with higher rating than that specified for your particular branch circuit. 2. Check for proper fuse; only "Fusetron" Type T fuses are acceptable. 3. Check for low voltage conditions. 4. Remove check valve and clean or replace if it is stuck open or closed. 5. Disconnect the other electrical appliances from circuit or operate the compressor on its own branch circuit. <p>Bleed the line by pushing the lever on the pressure switch to the "OFF" position, opening the pressure release valve. If the valve still doesn't open, it must be replaced.</p>
Restricted air intake.	Dirty air filter.	Replace with new.
Compressor is not supplying enough air to operate accessories.	<p>Prolonged excessive use of air.</p> <p>Compressor is not large enough for air requirement.</p> <p>Restricted air intake filter.</p> <p>Loose belt.</p> <p>Hole in hose.</p> <p>Check valve restricted.</p> <p>Air leaks.</p>	<p>Decrease amount of air usage.</p> <p>Check the accessory air requirement. If it is higher than the pressure supplied by your air compressor, you need a larger compressor.</p> <p>Replace air intake filter.</p> <p>Adjust belt tension.</p> <p>Check and replace if required.</p> <p>Remove and clean or replace.</p> <p>Tighten fittings. (See Air Leaks Section of Troubleshooting Guide.)</p>
Excessive belt wear.	<p>Loose belt.</p> <p>Tight belt.</p> <p>Loose pulley.</p>	<p>Adjust tension.</p> <p>Adjust tension.</p> <p>Check for worn keyway or pulley bore. Also check for bent motor shaft. Replace parts if necessary.</p>
Squealing sound.	<p>Loose belt.</p> <p>There is no oil in the compressor.</p>	<p>Adjust belt tension.</p> <p>Add oil.</p>

AIR COMPRESSOR DIAGRAM

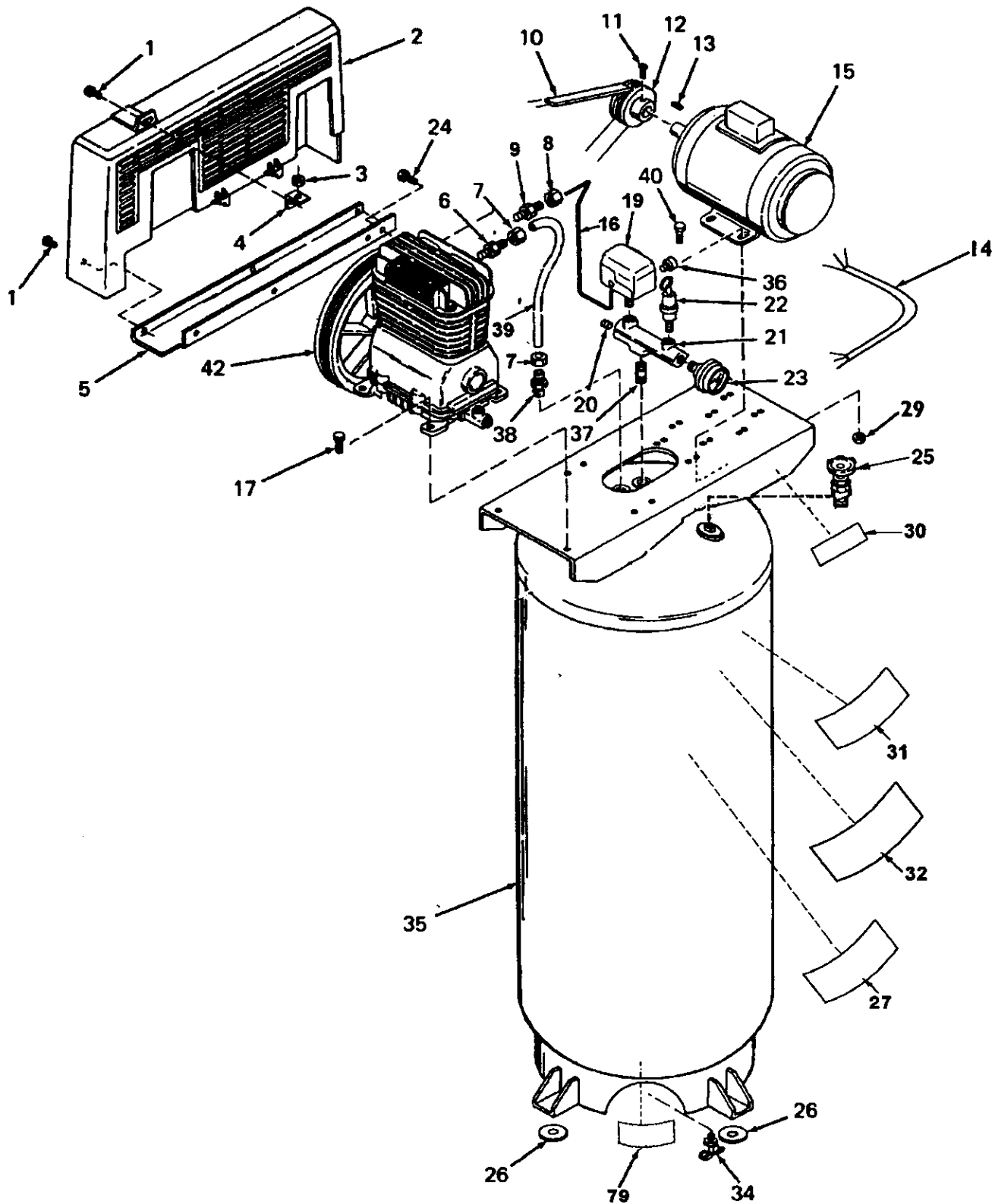



PARTS LIST

KEY NO.	PART NUMBER	DESCRIPTION
1	SSF-953-ZN	Self Tapping Screw 10 x 5/8 (6 used)
2	CAC-22-2	Belt Guard
3	SSF-8113-ZN	Lock Nut
4	CAC-2-1	Bracket
5	CAC-362-1	Belt Guard Closure
6	SSP-9401	Connector Body
7	SSP-7812	Nut-Sleeve Assembly 1/2" (2 used)
8	SSP-7811	Nut Sleeve Assembly 1/4"
9	SS-8553	Connector Body
10	C-BT-224	Poly-V Belt
11	SS-391	Set Screw
12	C-PU-2861	Motor Pulley
13	SUDL-65	Key, Motor Shaft
14	CAC-4205	Motor Cord Assembly
15	MO-3022-1	Motor 6.5 HP
16	CAC-1331	Pressure Release Tube
17	SSF-928	Cap Screw 5/16"-18-1" (4 used)
● 19	CAC-4336	Pressure Switch
20	SS-3222-CD	Pipe Plug
21	CAC-95	Manifold
22	TIA-4150	Safety Valve
23	GA-360	Gauge
24	39124607	Screw (2 used)
25	SSV-6	Globe Valve
26	SS-1525-CD	Isolator Washer (4 used)
27	LA-3294	Performance Label
29	SSF-8150	Locking Flange Nut (4 used)
30	CL-1263	Specification Label
31	LA-3266	Warning Label
32	LA-3105	Craftsman Label
34	SS-2707	Drain Valve
35	TA-4438	Air Receiver - 60 gal.
36	SSW-7367	Strain Relief
37	SS-2110	Nipple
38	CAC-437-2	Check Valve
39	AC-0720	Outlet Tube
40	SSF-3152	Locking Cap Screw (4 used)
41	LA-3108	Warning - Hot Surface Label (2 used)
42	AC-0722	Compressor Pump Assembly (includes Key No. 43 thru 78, inclusive)

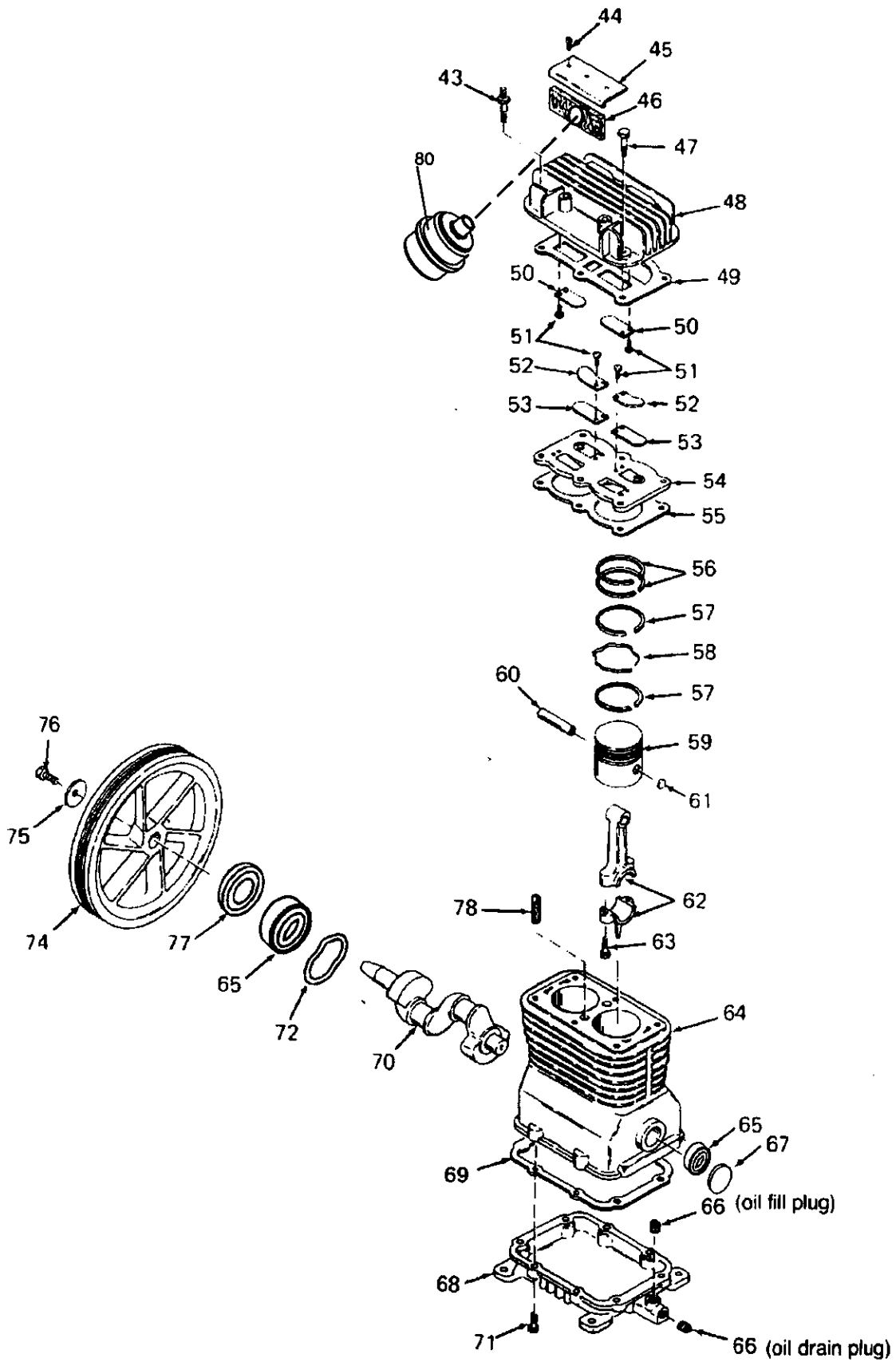
COMPRESSOR PUMP DIAGRAM



PARTS LIST

KEY NO.	PART NUMBER	DESCRIPTION
	43	SSF-6627 Stud 3/8" - 16 Taptite (1 used - Torque 25 to 30 ft. lbs.)
	44	SSF-935 Screw #8-32 x 3/8" (2 used)
	45	AC-0322 Filter Plate Assembly
*	46	AC-0333 Felt Filter
	47	SSF-955 Screw 3/8"-16 x 1-1/2" (5 used - Torque 25 to 30 ft. lbs.)
	48	CAC-4213 Head Assembly (includes 2 ea. Key #50 & 4 ea. Key #51)
*	49	CAC-291-1 Head Gasket
■	50	265-25 Intake Flapper Valve  (2 used on head)
■	51	SSF-9821 Screw, THD Forming 5-40x1/4 (8 used)
	52	CAC-294 Restrictor Plate (2 used)
■	53	265-196-1 Flapper Valve with Corner Bevels  (2 used on valve plate)
	54	CAC-4212-1 Valve Plate Assembly (includes 4 ea. Key #51 & 2 ea. Key #52 & 53)
*	55	CAC-54-2 Valve Plate Gasket
+	56	CAC-56-1 Compression Ring (4 used)
+	57	CAC-58 Oil Ring (4 used)
+	58	CAC-57 Oil Ring Expander (2 used)
	59	CAC-55-1 Piston (2 used)
	60	265-19 Piston Pin (2 used)
	61	CAC-207 Piston Pin Plug (4 used)
	62	265-410 Connecting Rod Assembly (2 used Includes two SSF-927 screws)
	63	SSF-927 Screw 1/4"-20 x 1-1/8" (2 used)
	64	AC-0205 Crankcase and Cylinder
	65	SST-104 Ball Bearing (2 used)
	66	SSP-486 Pipe Plug, 3/8-18" NPT (2 used)
*	67	SSP-505 Oil Plug
	68	DAC-276 Base
*	69	265-16-1 Base Gasket
	70	AC-0203 Crankshaft
	71	SSF-925 Screw 1/4 - 20 x 7/8" (8 used)
	72	SSN-1018 Wavy Spring Washer
	74	265-2 Flywheel
	75	SSN-1014-ZN Washer
	76	SSF-3039-ZN Screw
*	77	AC-0169 Oil Seal
*	78	265-6 Vent Filter
	79	LA-1923 Drain Tank Label
	80	AC-0330 Solberg Filter
	<u>NOT SHOWN</u>	
	AC-0331	Solberg Filter Replacement
	MGP-184160	Owners Manual

Parts Ordering Information

- + Key No. 56, 57, 58 only available in Ring Kit KK-4313.
- Key No. 19, pressure release valve and nut is available as part of Kit KK-5020.
- Key No. 50, 51 and 53 only available in Valve Kit KK-4275.
- * Key No. 46, 49, 55, 67, 69, 77, and 78 are available in Gasket Kit K-0159.

SEARS

OWNERS MANUAL

**MODEL NO.
919.184160**

When requesting service or ordering parts, always provide the following information:

- Model Number
- Part Number
- Part Description
- Name of Item

FULL ONE YEAR WARRANTY AIR COMPRESSOR

If this air compressor fails due to a defect in material or workmanship within one year from the date of purchase, **RETURN IT TO THE NEAREST SEARS REPAIR CENTER THROUGHOUT THE UNITED STATES AND SEARS WILL REPAIR IT, FREE OF CHARGE. IF PURCHASED FROM ORCHARD SUPPLY HARDWARE, RETURN TO THE NEAREST ORCHARD STORE AND ORCHARD WILL REPAIR IT, FREE OF CHARGE.**

If this air compressor is used for commercial or rental purposes, the warranty will apply for ninety days from the date of purchase.

This warranty gives you specific legal rights and you may have other rights which vary from state to state.

CRAFTSMAN. SINGLE STAGE AIR COMPRESSOR

For the repair or replacement parts you need

Call 7 am - 7 pm, 7 days a week

1-800-366-PART

(1-800-366-7278)



For in-home major brand repair service

Call 24 hours a day, 7 days a week

1-800-4-REPAIR

(1-800-473-7247)



For the location of a
Sears Parts and Repair Center in your area

Call 24 hours a day, 7 days a week

1-800-488-1222



For information on purchasing a Sears

Maintenance Agreement or to inquire

about an existing Agreement

call 9 am - 5 pm, Monday-Saturday

1-800-827-6655



SEARS
REPAIR SERVICES
America's Repair Specialists

Sears, Roebuck and Co., Hoffman Estates, IL 60179 U.S.A.