

## Operators Manual

# CRAFTSMAN®

**5 Horsepower**

**1900 PSI**

**2 GPM**

## HIGH PRESSURE WASHER

**Model No. 580.768110**

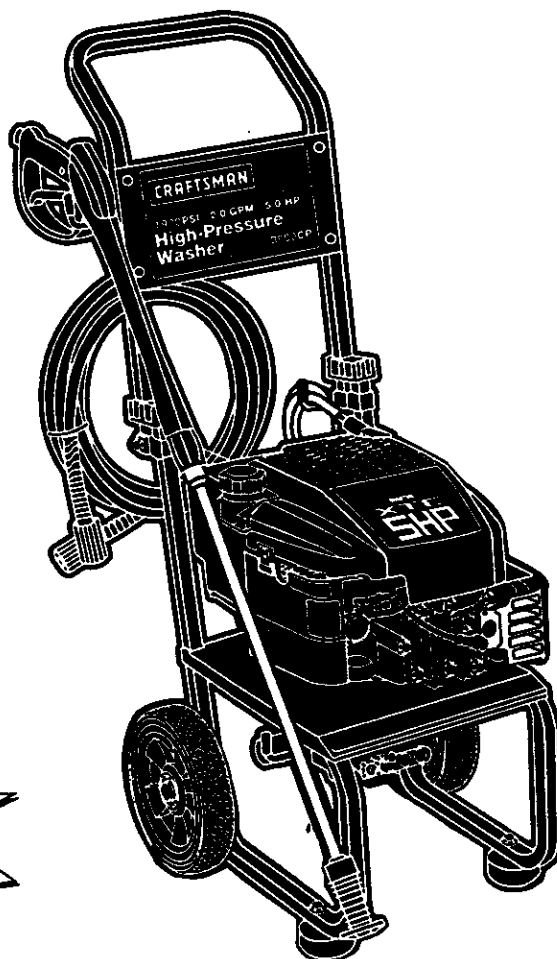

**HOURS: Mon. - Fri. 8 a.m. to 5 p.m. (CT)**

### **CAUTION:**

**Before using this product, read this manual and follow all its Safety Rules and Operating Instructions.**

**Sears, Roebuck and Co., Hoffman Estates, IL 60179**

Visit our Craftsman website: [www.sears.com/craftsman](http://www.sears.com/craftsman)

Part No. B3774 Draft 1 (4/19/1999) Printed in the U.S.A.

- **Safety**
- **Assembly**
- **Operation**
- **Maintenance**
- **Parts**

# TABLE OF CONTENTS

Safety Instructions . . . . .	2-3	Storage . . . . .	13
Assembly . . . . .	4	Troubleshooting . . . . .	14
Operation . . . . .	5-8	Replacements Parts . . . . .	16-27
Maintenance . . . . .	9-12	Order Parts / Request Service . . . . .	Back Page

# WARRANTY

## LIMITED ONE YEAR WARRANTY ON CRAFTSMAN HIGH PRESSURE WASHER

For one year from the date of purchase, when this Craftsman Cleaning System is maintained and operated according to the instructions in the owner's manual, Sears will repair, free of charge, any defect in material and workmanship.

If this washer is used for commercial purposes, this warranty applies for only 90 days from the date of purchase. If this high pressure washer is used for rental purposes, this warranty applies for only 30 days after date of purchase.

This warranty does not cover:

- Expendable items such as spark plugs or air filters, which become worn during normal use.
- Repairs necessary because of operator abuse or negligence, including damage resulting from no water being supplied to pump or failure to maintain the equipment according to the instructions contained in the owner's manual.

WARRANTY SERVICE IS AVAILABLE BY RETURNING THE HIGH PRESSURE WASHER TO THE NEAREST SEARS SERVICE CENTER OR DEALER IN THE UNITED STATES.

This warranty gives you specific legal rights and you may also have other rights, which vary from state to state.

Sears, Roebuck and Co., Dept. 817WA, Hoffman Estates, IL 60179

# SAFETY INSTRUCTIONS



## WARNING:



The engine exhaust from this product contains chemicals known to the State of California to cause cancer, birth defects, or other reproductive harm.



**CAUTION:** Before using this product, read this manual and follow all Safety Rules and Operating Instructions.



**DANGER:** When transporting, setting up, adjusting or making repairs to your pressure washer, **always** disconnect the spark plug wire and place it where it cannot contact the spark plug to prevent accidental starting.

- Engine exhaust gases contain **DEADLY** carbon monoxide gas. This dangerous gas, if breathed in sufficient concentrations, can cause unconsciousness or even death. Operate this equipment only in the open air where adequate ventilation is available.

- Gasoline is highly **FLAMMABLE** and its vapors are **EXPLOSIVE**. Do not permit smoking, open flames, sparks or heat in the vicinity while handling gasoline. Avoid spilling gasoline on a hot engine. Allow unit to cool for 2 minutes before refueling. Comply with all laws regulating storage and handling of gasoline.
- Locate this pressure washer in areas away from combustible materials, combustible fumes or dust.
- The high pressure equipment is designed to be used with Sears authorized parts only. If you use this equipment with parts that do not comply with minimum specifications, the user assumes all risks and liabilities.
- Some chemicals or detergents may be harmful if inhaled or ingested, causing severe nausea, fainting or poisoning. The harmful elements may cause property damage or severe injury.
- Do not allow **CHILDREN** to operate the Pressure Washer at any time.

- Operate engine only at governed speed. Running the engine at excessive speeds increases the hazard of personal injury. Do not tamper with parts which may increase or decrease the governed speed.
- Do not wear loose clothing, jewelry or anything that may be caught in the starter or other rotating parts.
- Before starting the Pressure Washer in cold weather, check all parts of the equipment and be sure ice has not formed there.
- Units with broken or missing parts, or without protective housing or covers should NEVER be operated.
- The muffler and air cleaner must be installed and in good condition before operating the Pressure Washer. These components act as spark arrestors if the engine backfires.
- Check the fuel system for leaks or signs of deterioration such as chafed or spongy hose, loose or missing clamps or damaged tank or cap. Correct all defects before operating the Pressure Washer.
- Do not spray flammable liquids.
- Never allow any part of the body to come in contact with the fluid stream. DO NOT come in contact with a fluid stream created by a leak in the high pressure hose.
- High pressure streams of fluid this equipment produces can pierce skin and its underlying tissues, leading to serious injury and possible amputation.
- Never aim the gun at people, animals or plants.
- High pressure spray can cause paint chips or other particles to become airborne and fly at high speeds.
- Always wear eye protection when you use this equipment or when you are in the vicinity where the equipment is in use.
- Operate the pressure at no more than the PSI fluid pressure rated for your pressure washer.
- Never move the machine by pulling on the high pressure hose. Use the handle provided on the top of the unit.
- Always be certain the spray gun, nozzles and accessories are correctly attached.
- Never use a spray gun which does not have a trigger lock or trigger guard in place and in working order.
- Use a respirator or mask whenever there is a chance that vapors may be inhaled. Read all instructions with the mask so you are certain the mask will provide the necessary protection against inhaling harmful vapors.
- High pressure spray may damage fragile items including glass. Do not point spray gun at glass when in the jet spray mode.
- Keep the hose connected to machine or the spray gun while the system is pressurized. Disconnecting the hose while the unit is pressurized is dangerous.
- Hold the spray gun firmly in your hand before you start the unit. Failure to do so could result in an injury from a whipping spray gun. Do not leave the spray gun unattended while the machine is running.
- The cleaning area should have adequate slopes and drainage to reduce the possibility of a fall due to slippery surfaces.
- Keep water spray away from electric wiring or fatal electric shock may result.
- Do not secure trigger gun in the pull-back (open) position.
- Do not by-pass any safety device on this machine.
- The muffler and engine heat up during operation and remain hot immediately after shutting it down. Avoid contact with a hot muffler or engine or you could be severely burned.
- Operate and store this unit on a stable surface.
- High pressure hose can develop leaks from wear, kinking, abuse, etc. Water spraying from a leak is capable of injecting material into skin. Inspect hose each time before using it. Check all hoses for cuts, leaks, abrasions or bulging of cover, or damage or movement of couplings. If any of these conditions exist, replace hose immediately. Never repair high pressure hose. Replace it with another hose that meets minimum pressure rating of your pressure washer.



**LOOK FOR THIS SYMBOL TO POINT OUT IMPORTANT SAFETY PRECAUTIONS. IT MEANS "ATTENTION!!! BECOME ALERT!!! YOUR SAFETY IS INVOLVED."**

# ASSEMBLY

## CARTON CONTENTS

The following parts are shipped loose with your pressure washer:

- Main Unit — pressure washer with wheels, guide handle.
- High Pressure Hose
- Parts Box (which includes items listed below)
  - Spray Gun
  - Wand Extension with Hi/Lo Adjustable Nozzle.
  - Engine Oil
- Manual Bag (which includes the items listed below)
  - Owner's Manual
  - Nozzle Cleaner Kit
  - "O"-Ring Kit

Become familiar with each piece before assembling the pressure washer. Check all contents against the illustration on Page 5. If any parts are missing or damaged, call the Pressure Washer Helpline at 1-800-222-3136.

## TO REMOVE PRESSURE WASHER FROM CARTON

- Remove loose parts and parts box included with pressure washer.
- Slice two corners at guide handle end of carton from top to bottom so the panel can be folded down flat.
- Raise guide handle, secure in place and roll the pressure washer out the open end of the carton.

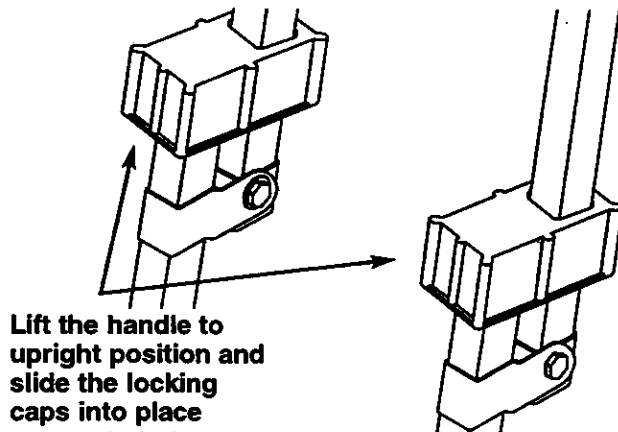

- Check carton for additional loose parts.

## HOW TO SET UP YOUR PRESSURE WASHER

For the most part, your Craftsman High Pressure Washer has been assembled at the factory. You must, however, assemble the spray gun, and attach the high pressure hose to the pump and spray gun.

- Cut the tie wraps on the high pressure hose and connect high pressure hose to gun. Tighten by hand.

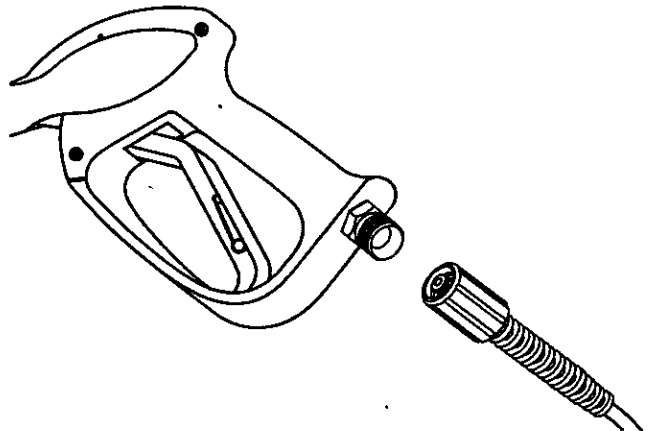

- Remove plastic cap and connect high pressure hose to pump. Tighten by hand.

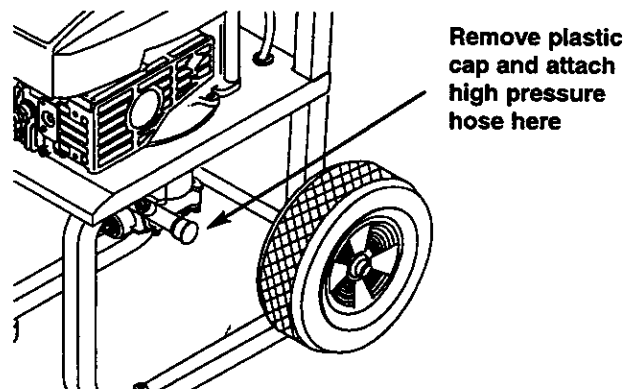

- Attach nozzle extension to spray gun.

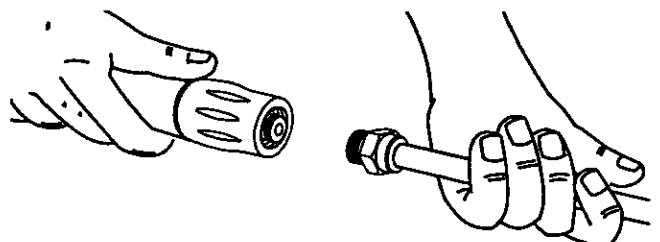

- Place assembled spray gun on holder.

# OPERATION

## KNOW YOUR HIGH PRESSURE WASHER

Read this owner's manual and safety rules before operating your high pressure washer. Compare this illustration with your high pressure washer to familiarize yourself with the locations of various controls and adjustments. Save this manual for future reference.

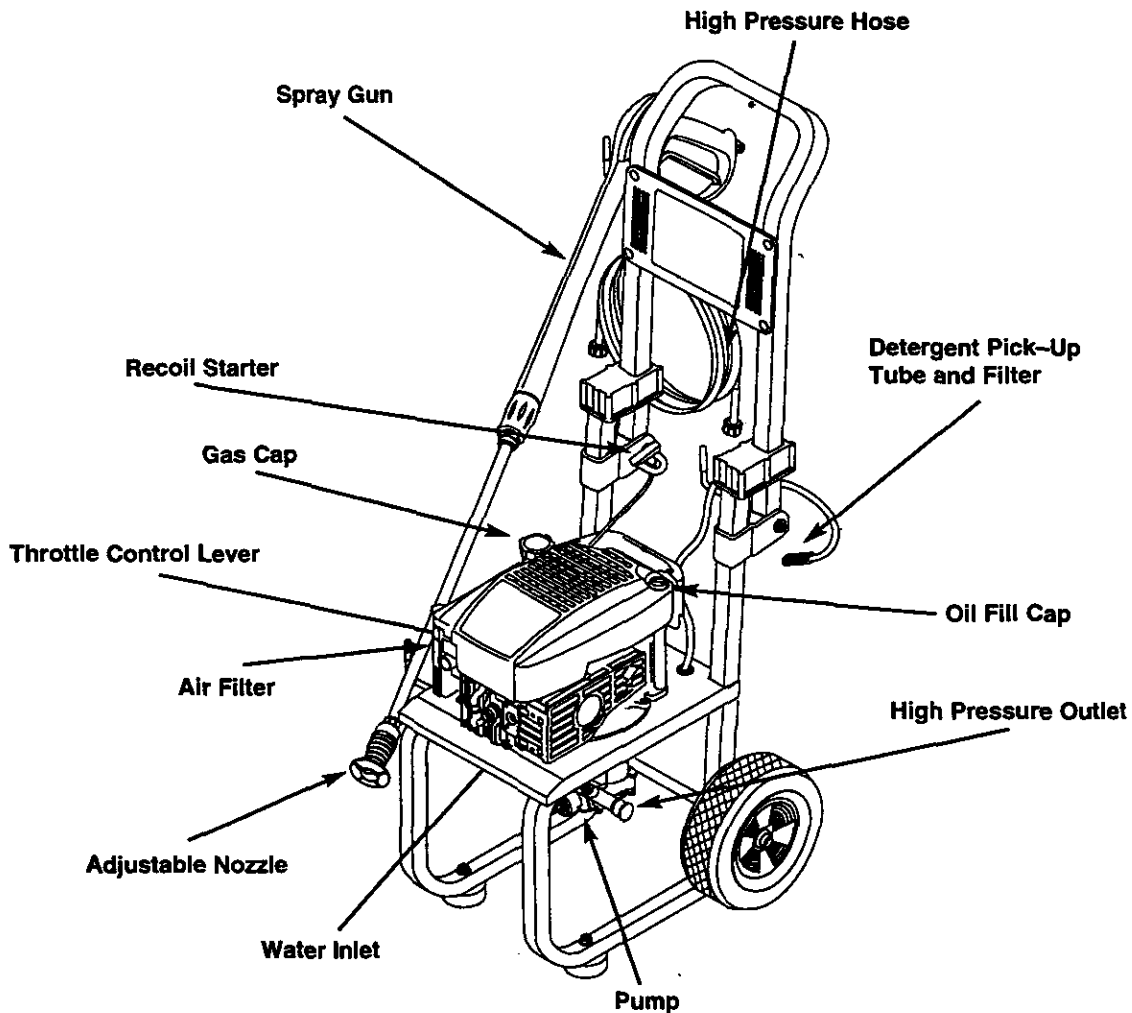

**Adjustable Nozzle** – Adjust for high or low pressure; narrow or fan spray.

**Air Filter** – Dry type filter element limits the amount of dirt and dust that gets in the engine.

**Detergent Pick-Up Tube and Filter** – Use to suck detergent from chemical bottle to the low pressure water stream.

**Gas Cap** – Fill gas tank with regular unleaded gasoline here.

**High Pressure Hose** – Connect one end to the spray gun and other end to the high pressure outlet.

**High Pressure Outlet** – Connection for high pressure hose.

**Oil Fill Cap** – Fill engine with oil here. See page 7 for oil recommendations.

**Pump** – Develops high water pressure.

**Recoil Starter** – Used for starting the engine manually.

**Spray Gun** – Controls the application of water onto cleaning surface with trigger device. Includes safety latch.

**Throttle Control Lever** – Sets engine in starting mode for recoil starter and stops running engine.

**Water Inlet** – Connection for garden hose.

## HOW TO USE YOUR PRESSURE WASHER

Read these instructions and learn how to use your pressure washer before you attempt to start your pressure washer. **If you have any problems** operating your pressure washer, please call the pressure washer helpline at **1-800-222-3136**.

### How To Use the Adjustable Nozzle

**WARNING:** Never adjust spray pattern when spraying. **Never** put hands in front of the nozzle when adjusting the spray.

- Push the nozzle forward for low pressure . Pull the nozzle backward to achieve high pressure.

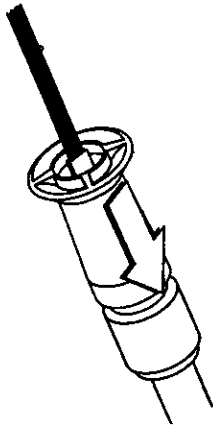

**Pull nozzle backward for high pressure.**

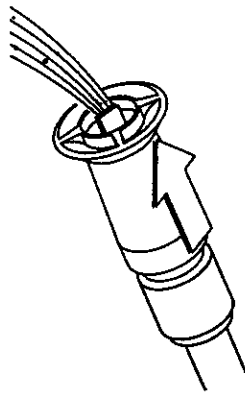

**Push nozzle forward for low pressure.**

- Twisting the nozzle adjusts the spray pattern from a narrow to a "fan" pattern.

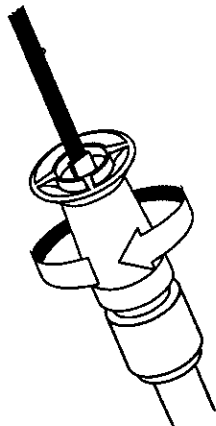

**Twist nozzle clockwise for narrow spray.**

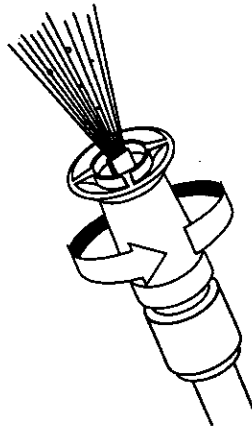

**Twist nozzle counterclockwise for "fan" pattern.**

- For most effective cleaning, keep spray nozzle between 8 to 24 inches away from cleaning surface.
- If you get the spray nozzle too close, especially using high pressure mode, you may damage the surface being cleaned.

### Cleaning With The Adjustable Nozzle

**IMPORTANT:** Use soaps designed specifically for pressure washers. Household detergents could damage the pump.

**IMPORTANT:** You must attach all hoses before you start the engine. Starting the engine without all the hoses connected and without the water turned ON will damage the pump.

**To apply detergent follow these steps:**

- Prepare the detergent solution as required by the job.
- Hang the detergent solution on the hook on the handle.

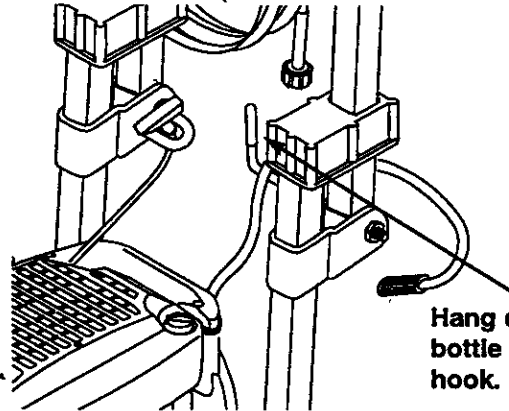

- Place small filter on the clear, chemical injection tube into the detergent container.
- Push the adjustable nozzle forward to low pressure mode. **Detergent cannot be applied with nozzle in high pressure position.**
- Review the use of the adjustable nozzle.
- Connect garden hose to water inlet (see "TO START PRESSURE WASHER" on page 8), check that high pressure hose is connected to spray gun and pump (see ASSEMBLY on page 4), and start engine.

**Note:** The first cleaning step is applying an appropriate cleaning solution to penetrate and loosen grime. Apply at low pressure. Leave the solution on surface for 3 to 5 minutes to allow solution to work. Reapply as needed to prevent surface from drying.

**Note:** The second step is cleaning the surface you have prepared with the pressure washer and then rinsing it clean.

- For cleaning, start at lower portion of area to be washed and work upward, using long, even overlapping strokes.
- Allow the detergent to soak in between 3-5 minutes before washing and rinsing. Reapply as needed to prevent surface from drying.

## Rinsing With the Pressure Washer



**WARNING:** Be extremely careful if you must use the pressure washer from a ladder, scaffolding or any other relatively unstable location. When you press the trigger, the recoil from the initial spray could force you to fall, or if you are too close to the cleaning surface, high pressure could force you off a climbing apparatus.

- Hook up the water supply and start your pressure washer (see TO START YOUR PRESSURE WASHER on page 8).
- Pull adjustable nozzle backward for high pressure mode. Wait for detergent to clear. Detergent will not flow when in the high pressure mode.
- When detergent has cleared, you may want to expand the spray pattern for a more gentle rinsing action. Start at top of area to be rinsed, working down with same action as for cleaning.



**CAUTION:** Test a small area of the surface to be cleaned. Make sure there is no damage caused by the high pressure spray.

## BEFORE STARTING THE PRESSURE WASHER

To operate the engine you will need to do the following:

### Add Engine Oil

Only use high quality detergent oil rated with API service classification SF or SG. Select the oil's SAE viscosity grade according to your expected operating temperature:

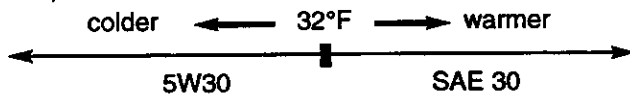

Although multi-viscosity oils (5W30, 10W30, etc.) improve starting in cold weather, these multi-viscosity oils will result in increased oil consumption when used above 32°F. Check your engine oil level more frequently to avoid possible damage from running low on oil.

- Place pressure washer on a level surface
- Clean area around oil fill and remove oil dipstick.
- Wipe dipstick clean.
- Pour oil from enclosed bottle into the oil fill opening until oil reaches **full** mark on the dipstick. Stop and check the oil level periodically. **Do not overfill.**
- Install oil dipstick, hand tighten securely.

### Add Gasoline

- Use **regular unleaded** gasoline with the pressure washer engine. Fuel tank capacity is 1.5 U.S. quart.



**DANGER:** Never fill fuel tank indoors. Never fill fuel tank when engine is running or hot. **Do not** smoke when filling fuel tank.



**CAUTION:** Do not overfill the fuel tank. Always leave room for expansion.



**CAUTION:** Experience indicates that alcohol blended fuels (called gasohol or using ethanol or methanol) can attract moisture which leads to separation and formation of acids during storage. Acidic gas can damage the fuel system of an engine while in storage.

### To add fuel to engine:

- Clean area around fuel cap, remove cap.
- Add **regular unleaded** gasoline, slowly, to the fuel tank.

**Important:** Never mix oil with gasoline.

- Install fuel cap and wipe up any spilled gasoline.

## TO START YOUR PRESSURE WASHER

- Place the pressure washer in an area close enough to an outside water source that can flow at a rate of at least 2 gallons per minute. Connect a garden hose to the water spout.
- Check that the high pressure hose is tightly connected to the spray gun and to the pump. See ASSEMBLY section on page 4 for illustrations.
- Check inlet screen on the water inlet. If the screen is dirty, clean before attaching a garden hose. If the screen is damaged, **do not** connect to the garden hose. Replace with screen provided in maintenance kit or call 1-800-366-PART to order a replacement inlet screen.
- Attach the the garden hose to the water inlet.
- **Turn on the water.**



**WARNING!** Do not run pump without the water supply connected and turned on. You must follow this warning or the pump will be damaged.

- Remove the adjustable nozzle extension from the spray gun.
- Pull the trigger on the spray gun and hold until a steady stream of water appears.
- Engage the safety latch on the spray gun.
- Attach adjustable nozzle extension onto spray gun.
- Move the throttle control lever to the "Fast" position.

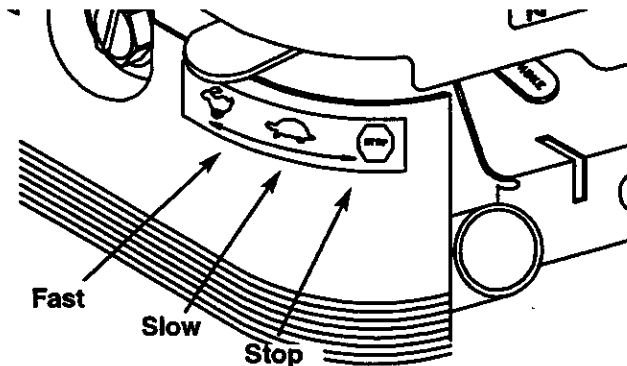

- Set the choke lever to "Choke" position.

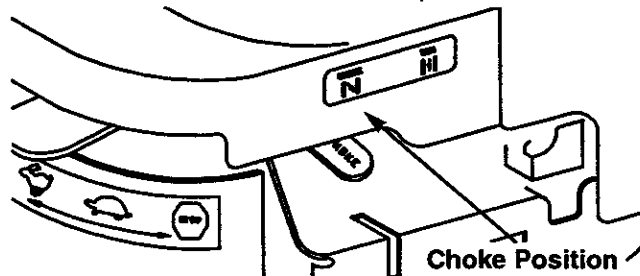

**Note:** For a recently run engine, be sure the throttle control is in the "Fast" position and the choke is in the "Run" position.

- Grasp rope handle and pull slowly until you feel some resistance. Then pull cord rapidly to overcome compression, prevent kickback and start the engine. Let rope return to starter **slowly**.

**Note:** Always keep the Throttle Control Lever in the 'Fast' position when operating the pressure washer.

- When the engine starts, gradually move the Choke Lever from one position to the next until it is in the "Run" position.

**Note:** If after 3 pulls the engine fails to start, move the Choke Lever to the 'Run' position, pull trigger on gun to relieve pressure, reengage safety latch, and pull the recoil starter handle rapidly (Max. 3 pulls).

## HOW TO STOP YOUR PRESSURE WASHER

- Move the Run/Stop Lever to the 'Stop' position.
- **Simply shutting off the engine will not release pressure in the system.** Squeeze trigger on the spray gun to relieve pressure in the hose.

**Note:** A small amount of water will squirt out when you release the pressure.

## SIPHONING

We recommend that you **DO NOT** siphon standing water for your water supply. Contaminated, brackish or dirty water can damage the pump. Connect only to household water supply.

## TIPS

- Never use the garden hose inlet to siphon detergent or wax.
- If you have the spray nozzle too far away, the cleaning will not be as effective.



# MAINTENANCE

## CUSTOMER RESPONSIBILITIES

<b>MAINTENANCE SCHEDULE</b> FILL IN DATES AS YOU COMPLETE REGULAR SERVICE  <b>MAINTENANCE TASK</b>	<b>HOURLY OPERATING INTERVAL</b>			<b>SERVICE DATES</b>			
	Before Each Use	Every 25 Hours or Yearly	Every 100 Hours or Yearly				
<b>PRESSURE WASHER</b>							
Check/clean water inlet screen on quick-connect.	X†						
Check high pressure hose.	X						
Check detergent hose.	X						
Check spray gun and assembly for leaks.	X						
Purge pump of air and contaminants.	X						
<b>ENGINE</b>							
Check oil level.	X						
Change engine oil.		X*					
Service air cleaner.			X**				
Clean/replace spark plug.			X				
Prepare for storage.	Prepare unit for storage if it is to remain idle for longer than 30 days.						

† Clean if clogged. Replace if perforated or torn.

\* Change oil after the first (2) operating hours and every 25 hours thereafter. Change sooner when operating under dirty or dusty conditions.

\*\* Replace more often under dirty or dusty conditions.

## PRODUCT SPECIFICATIONS

### Pressure Washer Specifications

PRESSURE .....	1900 psi
FLOW RATE.....	2 GPM
DETERGENT MIX....	Use undiluted detergent
WATER SUPPLY TEMPERATURE .....	Not to Exceed 140°F

### Engine Specifications

ENGINE MODEL.....	Briggs & Stratton
RATED HORSEPOWER .....	5
SPARK PLUG: Type: ...	Champion RJ-19LM or equivalent. Set Gap to: ...0.030 inch (0.76mm)
GASOLINE CAPACITY.....	1.5 U.S. quart
OIL .....	SAE 30 weight
SOLID STATE .....	0.006 – .010 inch
IGNITION AIR GAP	

In the State of California a spark arrestor is required by law (Section 4442 of the California Public Resources Code). Other states may have similar laws. Federal laws apply on federal lands.

**Note:** If you equip the engine of your pressure washer with a spark arrestor muffler, the spark arrestor must be maintained in effective working order by the owner/operator.

You can order a spark arrestor (P/N 398067) through your Sears Service Center.

### GENERAL RECOMMENDATIONS

The warranty of the high pressure washer does not cover items that have been subjected to operator abuse or negligence. To receive full value from the warranty, operator must maintain high pressure washer as instructed in this manual.

Some adjustments will need to be made periodically to properly maintain your high pressure washer.

All adjustments in the Service and Adjustments section of this manual should be made at least once each season.

- Once a year you should clean or replace the spark plug and replace the air filter and check the gun and wand assembly for wear. A clean spark plug and new air filter assure proper fuel-air mixture and help your engine run better and last longer.

## BEFORE EACH USE

- Check water inlet screen for damage.
- Check high pressure hose for leaks.
- Check detergent inlet hose and filter for damage.
- Check gun and wand assembly for leaks.
- Purge pump of air and contaminants.
- Check engine oil level.

## PRESSURE WASHER MAINTENANCE

### Check and Clean Inlet Screen

Examine inlet screen. Clean if it is clogged or replace if it is torn.

### Check High Pressure Hose

High pressure hose can develop leaks from wear, kinking, or abuse. Inspect hose each time before using it. Check for cuts, leaks, abrasions, bulging of cover, or damage or movement of couplings. If any of these conditions exist, replace hose immediately.



**DANGER: Never repair** a high pressure hose. **Replace** with hose that meets the minimum pressure rating of your pressure washer

### Check Detergent Hose

Examine the filter on the detergent hose and clean if clogged. Hose should fit tightly on barbed fitting. Examine hose for leaks or tears. Replace the filter or hose if either is damaged.

### Check In-Line Filter

Refer to the following illustration and service the in-line filter if it becomes clogged, as follows:

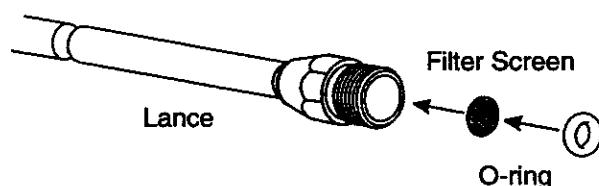

1. Detach gun and lance from high pressure hose. Detach lance from gun and remove o-ring and screen from lance. Flush the screen, gun, and lance with clean water to clear debris.
2. If the screen is damaged, the o-ring kit contains a replacement in-line filter screen and an o-ring. If undamaged, reuse screen.
3. Place the in-line filter screen into the threaded end of the lance. Direction does not matter. Push the screen in with the eraser end of a pencil until it rests flat at the bottom of the opening. Take care to not bend the screen.
4. Place the o-ring into the recess. Push the o-ring snugly against the in-line filter screen.
5. Assemble the lance to the spray gun, as described earlier in this manual.

## Check Gun and Wand

Examine hose connection to gun and make sure it is secure. Test trigger by pressing it and making sure it springs back into place when you release it. Put safety latch in UP position and test trigger. You should not be able to press trigger. Replace gun immediately if it fails any of these tests.

## Purge Pump of Air and Contaminants

To remove the air from the pump, follow these steps:

- Set up the pressure washer as described in the ASSEMBLY section on page 4 and connect the water supply.
- Remove the wand extension from the gun.
- Pull the trigger on the gun and hold until a steady stream of water appears.

To remove the contaminants from the pump, follow these steps:

- Set up the pressure washer as described in the ASSEMBLY section, and connect the water supply.
- Remove the nozzle attachment from the gun.
- Start the engine according to instructions in OPERATION section.
- Pull the trigger on the gun and hold.
- When the water supply is steady and constant, engage the safety latch and refasten the nozzle attachment.

## Nozzle Maintenance

If the nozzle becomes restricted or clogged with foreign materials, such as dirt, excessive pump pressure may develop. A partially clogged nozzle can cause a pulsing sensation during use. This generally is not a pump related problem, but rather a clogged or partially restricted nozzle.

If the nozzle becomes clogged or partially restricted, immediately clean the nozzle with the kit included with your pressure washer by following these instructions:

- Shut off the engine and turn off the water supply.
- Separate the wand from the gun.
- Rotate to stream setting.
- Remove nozzle from the end of the wand using the allen wrench included with the kit or a 2mm or 5/64 allen wrench.

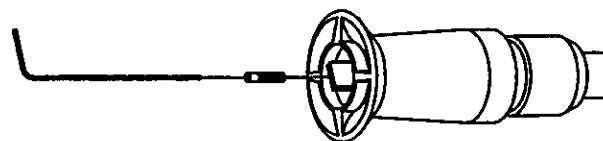

- Use the wire included in the kit or a small paper clip to free the foreign materials clogging or restricting the nozzle.

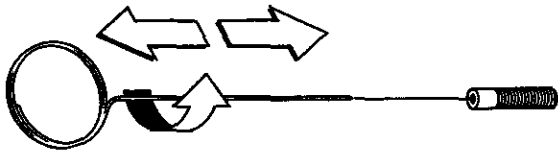

Insert wire into nozzle and turn back and forth to clear obstruction.

- Remove additional debris by back flushing water supply through wand. Back flush between 30 to 60 seconds. Turn wand to stream spray and move nozzle from low to high pressure while flushing.

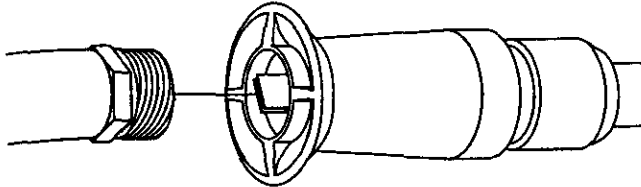

- Reinstall nozzle into wand. DO NOT overtighten.
- Reconnect wand extension to spray gun.
- Reconnect the water supply, turn ON the water, and start the engine.
- Test the pressure washer by operating with nozzle in the high and the low pressure positions.

### O-Ring Maintenance

Through the normal operation of your pressure washer, O-Rings, which keep the connections of the hoses and gun tight and leak-free may become worn or damaged. Provided with your pressure washer is an O-Ring Maintenance Kit which provides replacement O-Rings, Rubber Washer and water inlet screen.

### Parts in the O-Ring Kit Include:

- 1 o-ring, red, (p/n B2726) for the end of the spray gun connection between gun and high/low spray wand.

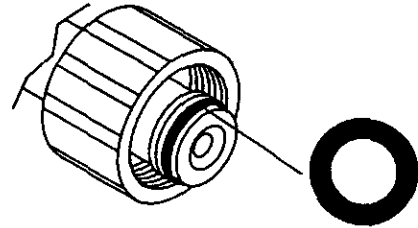

- 2 o-rings, yellow, (p/n B2264) for the ends of the high pressure hose.

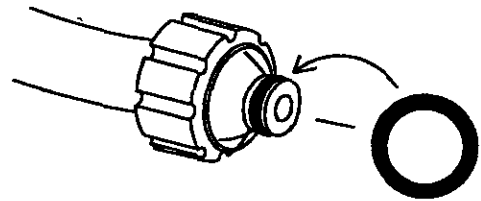

**Note:** The above two o-rings are close in size. Please match carefully to assure proper o-ring usage.

- 1 rubber washer (p/n B2385) for the inside of the garden hose connector.

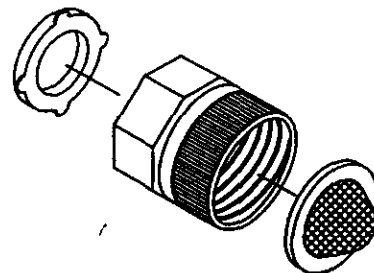

- 1 water inlet screen (p/n B2384) for the garden hose connector.

### To remove a worn or damaged O-Ring:

- Use a small flathead screwdriver to get underneath the o-ring and pry it off.

## ENGINE MAINTENANCE

**Maintenance, replacement or repair of the emission control devices and systems may be performed by any non-road engine repair establishment or individual.**

### Checking Oil Level

Oil level should be checked prior to each use or at least every 5 hours of operation. Keep oil level maintained.

### Changing Oil

Change engine oil after the first two hours and every 25 hours thereafter. If you are using your pressure washer under extremely dirty or dusty conditions, or in extremely hot weather, change oil more often.

Change oil while engine is still warm from running, as follows:

- Drain fuel tank by running pressure washer until fuel tank is empty.
- Clean area around oil fill, remove oil fill cap/dipstick. Wipe dipstick clean.
- Tip your pressure washer to drain oil from the oil fill tube into a suitable container. When crankcase is empty, return the pressure washer to upright position.
- Fill engine crankcase with recommended oil until oil level is at **FULL** point on dipstick. Do not overfill above that mark. **POUR SLOWLY.**
- When engine crankcase is filled to proper level, install and tighten oil cap/dipstick.

### Service Air Cleaner

Your engine will not run properly and may be damaged if you run it with a dirty air cleaner.

Replace the air cleaner once every 100 hours of operation or once each year, whichever comes first. Replace more often if operating under dirty or dusty conditions. Do not attempt to clean or oil filter. Replacements are available at your local Sears Authorized Service Center.

To clean or replace the air cleaner, follow these steps:

- Remove screw on the air cleaner cover.
- Remove dirty air cleaner carefully to prevent debris from falling into carburetor. Discard.
- Clean inside of filter case.
- Install new air filter.
- Reassemble all parts and fasten securely to the carburetor with the screw.

### Clean / Replace Spark Plug

Clean or replace the spark plug yearly or every 100 hours of operation.



**CAUTION:** Disconnect spark plug wire from spark plug and keep wire away from spark plug.

- Clean area around spark plug.
- Remove and inspect spark plug.
- Replace spark plug if the electrodes are pitted, burned or porcelain is cracked. For replacement use Champion RJ-19LM only.
- Check electrode gap with wire feeler gauge and set gap at 0.030 inches if necessary.

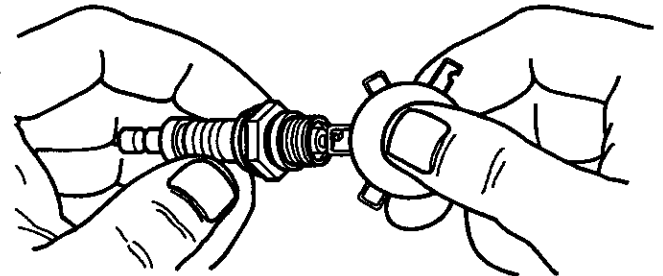

- Install spark plug, tighten securely.

### Carburetor

If you think your carburetor needs adjusting, see your nearest Sears Service Center. Engine performance should not be affected at altitudes up to 5000 feet. For operation at higher elevations, contact your nearest Sears Service Center.

# STORAGE

## AFTER EACH USE

Water should not remain in the unit for long periods of time. Sediments of minerals can deposit on pump parts and “freeze” pump action. Follow these procedures after every use:

- Flush detergent hose by placing the injector filter into a pail of clear water while running Pressure Washer with nozzle in low pressure mode. Flush until you can see clear water running through the tube.
- Shut off the engine and let it cool, then remove all hoses.



**CAUTION:** Be sure the Run/Stop Lever is in the “Stop” position before you continue. If you start the engine without the proper water supply connected, you can damage the pump.

- Empty the pump of all pumped liquids by pulling recoil handle about 6 times with the Run/Stop Lever in the “Stop” position. This should remove most of the liquid in the pump.
- Coil the high pressure hose and inspect it for damage. Cuts in the hose or fraying of it could result in leaks and loss of pressure. Should any damage be found, replace the hose. DO NOT attempt to repair a damaged hose. Replace the hose with the genuine Craftsman part.
- Drain water from hose and properly hang it on the wire support provided on the guide handle.
- Store in a clean, dry area.



**DANGER:** Never store the engine with fuel in the gas tank indoors or in enclosed, poorly ventilated areas where fumes may reach an open flame, a spark, or pilot light.

## WINTER STORAGE



**CAUTION:** You must protect your unit from freezing temperatures. Failure to do so will permanently damage your pump and render your unit inoperable.

**To protect the unit from freezing temperatures:**

- Draw RV-Antifreeze (antifreeze without alcohol) into the pump by pouring the washer fluid into a 3-foot section of garden hose connected to the inlet adapter and pulling the recoil handle twice.

## LONG TERM STORAGE

If you do not plan to use the Pressure Washer for more than 30 days, you must prepare the engine for long term storage.

**Note:** As always, prepare the pressure washer pump as you would after each use.

It is important to prevent gum deposits from forming in essential fuel system parts such as the carburetor, fuel filter, fuel hose or tank during storage. Also, experience indicates that alcohol-blended fuels (called gasohol, ethanol or methanol) can attract moisture which leads to separation and formation of acids during storage. Acidic gas can damage the fuel system of an engine while in storage.

## Protect Fuel System



**DANGER:** Drain fuel into approved container outdoors, away from open flame. Be sure engine is cool. Do not smoke.

- Remove all gasoline from the fuel tank to prevent gum deposits from forming on these parts and causing possible malfunction of engine.
- Run engine until engine stops from lack of fuel. Make sure you have water supply to pump inlet connected and turned ON.

## Change Oil

While engine is still warm, drain oil from crankcase. Refill with recommended grade. (See Changing Oil on Page 12.)

## Oil Cylinder Bore

- Remove spark plug and pour about 1 ounce (30 ml) of engine oil into the cylinder. Cover spark plug hole with rag. Crank slowly to distribute oil.



**CAUTION:** Avoid spray from spark plug hole when cranking engine slowly.

- Install spark plug. Do not connect spark plug wire.

## OTHER

- Do not store gasoline from one season to another.
- Replace your gasoline can if your can starts to rust. Rust and/or dirt in your gasoline will cause problems.
- If possible, store your unit indoors and cover it to give protection from dust and dirt. **BE SURE TO EMPTY THE FUEL TANK.**
- Cover your unit with a suitable protective cover that does not retain moisture.

**IMPORTANT:** NEVER cover your pressure washer while engine and exhaust area are warm.

# TROUBLESHOOTING

PROBLEM	CAUSE	CORRECTION
<p>Pump has following problems: failure to produce pressure, or erratic pressure, chattering, loss of pressure, low water volume.</p>	<ol style="list-style-type: none"> <li>1. Nozzle in low pressure mode.</li> <li>2. Water inlet is blocked.</li> <li>3. Inadequate water supply</li> <li>4. Inlet hose is kinked or leaking</li> <li>5. Clogged water inlet screen.</li> <li>6. Water supply is over 140°F.</li> <li>7. Outlet hose is blocked.</li> <li>8. Outlet hose leaks.</li> <li>9. Gun leaks.</li> <li>10. Nozzle is obstructed.</li> <li>11. Pump is faulty.</li> </ol>	<ol style="list-style-type: none"> <li>1. Pull nozzle backward for high pressure mode.</li> <li>2. Clear inlet</li> <li>3. Provide adequate water flow at least 2 gpm.</li> <li>4. Straighten inlet hose, patch leak.</li> <li>5. Replace / clean water inlet screen.</li> <li>6. Provide cooler water supply.</li> <li>7. Clear blocks in outlet hose.</li> <li>8. Replace outlet hose if leaking.</li> <li>9. Replace o-ring or gun if necessary.</li> <li>10. Clear nozzle.</li> <li>11. Contact Sears Service Department.</li> </ol>
<p>Detergent fails to mix.</p>	<ol style="list-style-type: none"> <li>1. Detergent line is not submerged.</li> <li>2. Chemical filter is clogged.</li> <li>3. Nozzle is in high pressure mode.</li> </ol>	<ol style="list-style-type: none"> <li>1. Insert chemical line into detergent.</li> <li>2. Clean or replace filter/detergent line.</li> <li>3. Push nozzle forward for low pressure mode.</li> </ol>
<p>Engine runs good when not spraying but dies when you begin to spray.</p>	<p>Engine speed is too slow.</p>	<p>Contact Sears Service Department.</p>
<p>Engine will not start; or starts and runs rough</p>	<ol style="list-style-type: none"> <li>1. Dirty air cleaner</li> <li>2. Out of gasoline.</li> <li>3. Stale gasoline.</li> <li>4. Spark plug wire not connected to spark plug.</li> <li>5. Bad spark plug.</li> <li>6. Water in gasoline.</li> <li>7. Overchoking or flooded</li> <li>8. Excessively rich fuel mixture.</li> <li>9. Intake valve stuck open or closed.</li> <li>10. Engine has lost compression.</li> </ol>	<ol style="list-style-type: none"> <li>1. Clean or replace air cleaner.</li> <li>2. Fill fuel tank.</li> <li>3. Drain gas tank; fill with fresh fuel.</li> <li>4. Connect wire to spark plug.</li> <li>5. Replace spark plug.</li> <li>6. Drain gas tank; fill with fresh fuel.</li> <li>7. Set engine throttle control lever to fast position, choke in run position.</li> <li>8. Contact Sears Service Department.</li> <li>9. Contact Sears Service Department.</li> <li>10. Contact Sears Service Department.</li> </ol>
<p>Engine shuts down during operation</p>	<ol style="list-style-type: none"> <li>1. Out of gasoline.</li> <li>2. Air filter dirty</li> </ol>	<ol style="list-style-type: none"> <li>1. Fill fuel tank.</li> <li>2. Replace Air filter.</li> </ol>
<p>Engine lacks power.</p>	<p>Dirty air filter.</p>	<p>Replace air filter.</p>

# NOTES

# PARTS

Craftsman 1900 PSI High Pressure Washer 580.768110  
Briggs & Stratton 5HP Quantum, Model 12F802-2407-E2

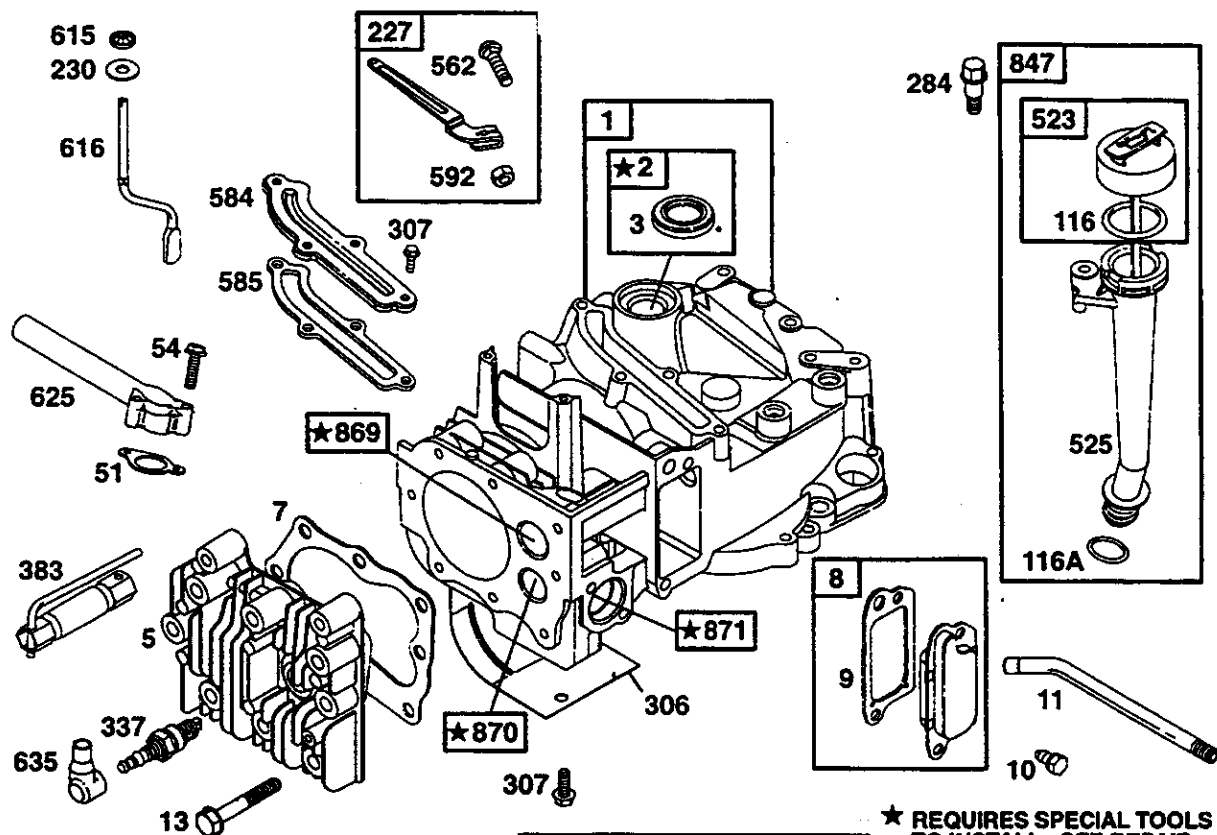

1058 OWNER'S MANUAL

★ REQUIRES SPECIAL TOOLS TO INSTALL. SEE REPAIR INSTRUCTION MANUAL.

REF. NO.	PART NO.	DESCRIPTION	REF. NO.	PART NO.	DESCRIPTION	REF. NO.	PART NO.	DESCRIPTION
1	493260	Cylinder Assembly	227	492349	Lever-Governor	616	263175	Crank-Governor
2	293708	Bushing	230	67072	Washer	625	497465	Manifold-Intake
3	★299819	Seal-Oil	284	94511	Screw-Shoulder	635	66538	Boot-Spark Plug
5	214626	Head-Cylinder	306	224324	Shield-Cylinder	847	495263	Dipstick/Tube Assembly
7	★272916	Gasket-Cylinder Head	307	94515	Screw-Hex.	869	213512	Seat-Valve (Intake)
8	495786	Breather Assembly	337	802592	Plug-Spark	870	213513	Seat-Valve (Exhaust)
9	★272481	Gasket-Breather	383	89838	Wrench-Spark Plug	871	262001	Bushing-Guide (Exhaust Valve)
10	94650	Screw-Hex.	523	495264	Dipstick			Note
11	231685	Tube-Breather	525	495265	Tube-Oil Fill			63709 Bushing-Guide (Intake Valve)
13	94547	Screw-Hex.	562	92613	Bolt-Carriage			
51	★272199	Gasket-Intake	584	224328	Baffle-Cylinder			
54	94526	Screw-Hex.	585	★272238	Gasket-Breather			
116	★280393	Seal-O-Ring	592	231082	Nut-Hex.			
116A	★280966	Seal-O-Ring	615	94474	Retainer	1058	273693	Owner's Manual

★ Included in Gasket Set-Part Number 497316.  
● Included in Carburetor Kit-Part Number 498260.

◆ Included in Carburetor Gasket Set-Part Number 498261.  
⊘ Included in Valve Overhaul Gasket Set-Part No. 498528.

Assemblies include all parts shown in frames.



**Craftsman 1900 PSI High Pressure Washer 580.768110  
Briggs & Stratton 5HP Quantum, Model 12F802-2407-E2**

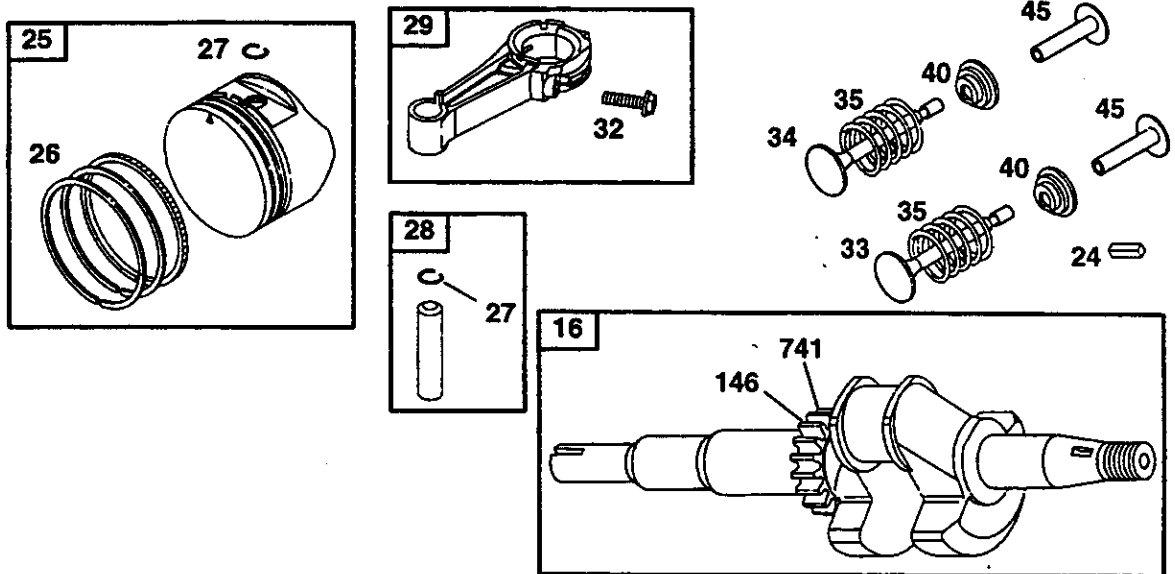

REF. NO.	PART NO.	DESCRIPTION	REF. NO.	PART NO.	DESCRIPTION	REF. NO.	PART NO.	DESCRIPTION
16	498571	Crankshaft	28	499423	Pin-Piston (Standard)	34	262652	Valve-Intake
24	222698	Key-Flywheel	29	499424	Rod-Connecting (Standard)	35	262224	Spring-Valve
25	499429	Piston Assembly (Standard)	32	94699	Screw-Hex.	40	93312	Retainer-Valve
26	499425	Ring Set (Standard)	33	262651	Valve-Exhaust	45	262204	Tappet-Valve
27	263190	Lock-Piston Pin				146	94388	Key-Timing
						741	262598	Gear-Timing

★ Included in Gasket Set-Part Number 497316.  
● Included in Carburetor Kit-Part Number 498260.

◆ Included in Carburetor Gasket Set-Part Number 498261.  
∅ Included in Valve Overhaul Gasket Set-Part No. 498528.

**Assemblies include all parts shown in frames.**

**Craftsman 1900 PSI High Pressure Washer 580.768110  
Briggs & Stratton 5HP Quantum, Model 12F802-2407-E2**

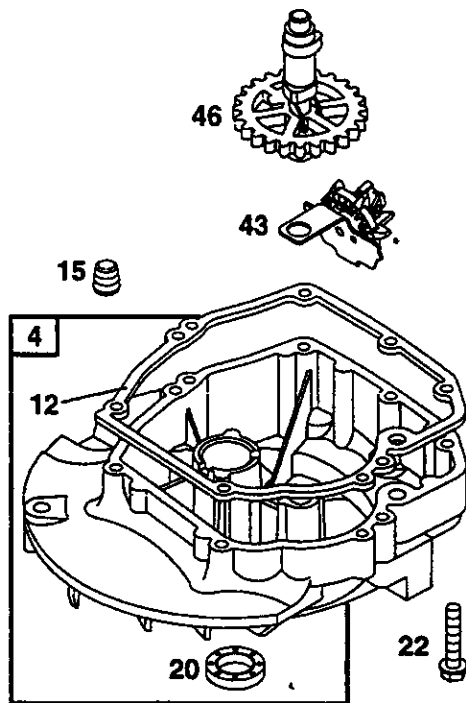

REF. NO.	PART NO.	DESCRIPTION	REF. NO.	PART NO.	DESCRIPTION	REF. NO.	PART NO.	DESCRIPTION
4	493279	Sump-Engine	20	★399781	Seal-Oil	43	493737	Governor/Oil Slinger
12	★272198	Gasket-Crankcase	22	94220	Screw-Hex.	46	498275	Gear-Cam
15	94720	Plug-Oil Drain						

★ Included in Gasket Set-Part Number 497316.  
● Included in Carburetor Kit-Part Number 498260.

◆ Included in Carburetor Gasket Set-Part Number 498261.  
∅ Included in Valve Overhaul Gasket Set-Part No. 498528.

**Assemblies include all parts shown in frames.**

**Craftsman 1900 PSI High Pressure Washer 580.768110  
Briggs & Stratton 5HP Quantum, Model 12F802-2407-E2**

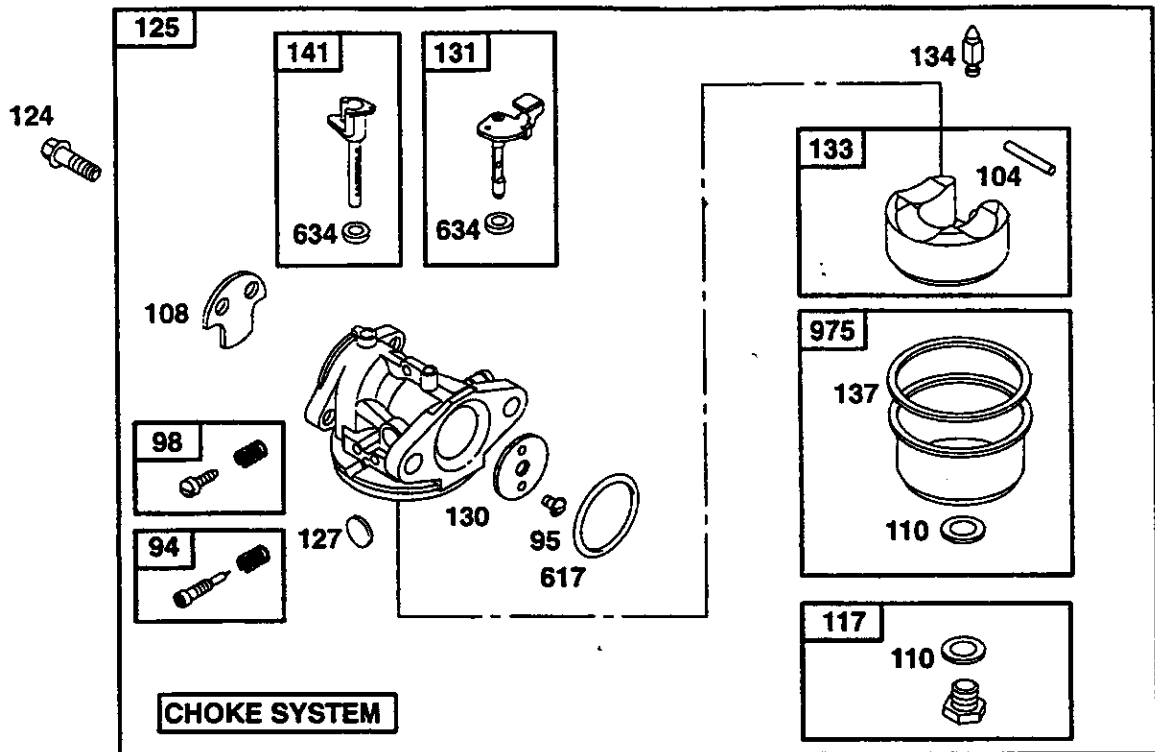

REF. NO.	PART NO.	DESCRIPTION	REF. NO.	PART NO.	DESCRIPTION	REF. NO.	PART NO.	DESCRIPTION
94	◆493765	Valve-Idle Adjustment	124	94525	Screw-Hex.	141	494218	Shaft-Choke
95	94098	Screw-Slotted	125	499059	Carburetor	617	◆◆270344	Seal-Intake Manifold
98	398185	Screw-Idle Speed	127	●	Plug-Welch (Sold in Kit Only)	634	◆◆	Washer (Sold in Kit Only)
104	◆231371	Pin-Float Hinge	130	223470	Valve-Throttle	975	493640	Bowl-Float
108	223471	Valve-Choke	131	493267	Shaft-Throttle			
110	◆◆	Seal-O-Ring (Sold in Kit Only)	133	398187	Float-Carburetor			
117	498978	Jet-Main (Standard) 497315 Jet-Main (High Altitude)	134	◆398188	Valve-Needle (Includes Seal)			
			137	◆◆	Gasket-Float Bowl (Sold in Kit Only)			

★ Included in Gasket Set-Part Number 497316.  
● Included in Carburetor Kit-Part Number 498260.

◆ Included in Carburetor Gasket Set-Part Number 498261.  
◆◆ Included in Valve Overhaul Gasket Set-Part No. 498528.

**Assemblies include all parts shown in frames.**

**Craftsman 1900 PSI High Pressure Washer 580.768110  
Briggs & Stratton 5HP Quantum, Model 12F802-2407-E2**

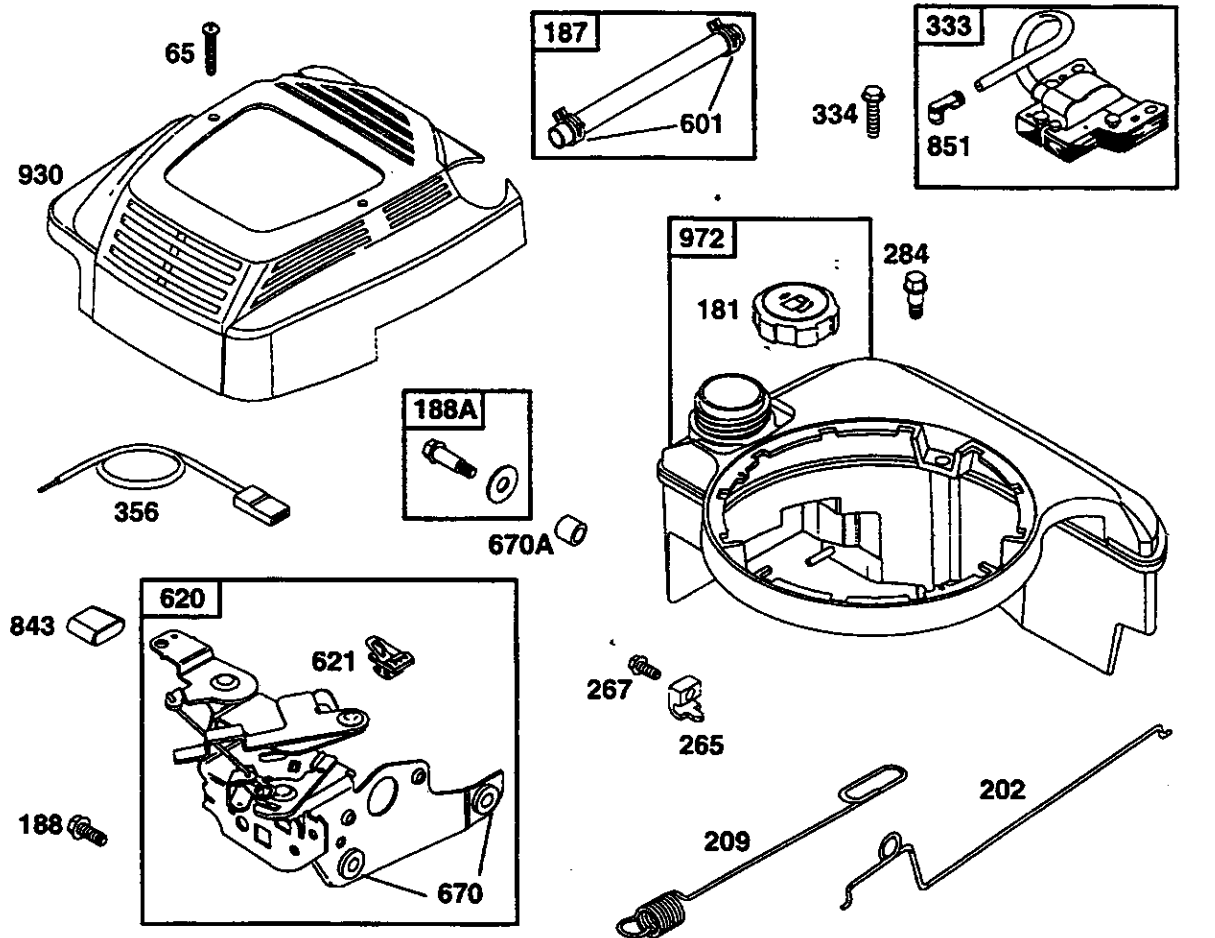

REF. NO.	PART NO.	DESCRIPTION	REF. NO.	PART NO.	DESCRIPTION	REF. NO.	PART NO.	DESCRIPTION
65	94696	Screw-Phillips	265	213146	Clamp-Casing	620	499737	Bracket-Control
181	397974	Cap-Fuel Tank	267	94694	Screw-Slotted Hex.	621	396847	Switch-Stop
187	298049	Line-Fuel (Cut To Required Length)	284	94511	Screw-Shoulder	670	★493823	Spacer
188	94644	Screw-Hex.	333	802574	Armature-Magneto	670A	280512	Spacer-Fuel Tank
188A	398540	Screw-Shoulder	334	94731	Screw-Hex.	843	272616	Sleeve-Lever
202	262579	Link-Mechanical Gov.	356	497833	Wire-Stop	930	281440	Cover-Blower Housing
209	692488	Spring-Governor	601	95162	Clamp-Hose (Green)	972	495224	Tank-Fuel

★ Included in Gasket Set-Part Number 497316.  
● Included in Carburetor Kit-Part Number 498260.

◆ Included in Carburetor Gasket Set-Part Number 498261.  
⊗ Included in Valve Overhaul Gasket Set-Part No. 498528.

**Assemblies include all parts shown in frames.**

**Craftsman 1900 PSI High Pressure Washer 580.768110  
Briggs & Stratton 5HP Quantum, Model 12F802-2407-E2**

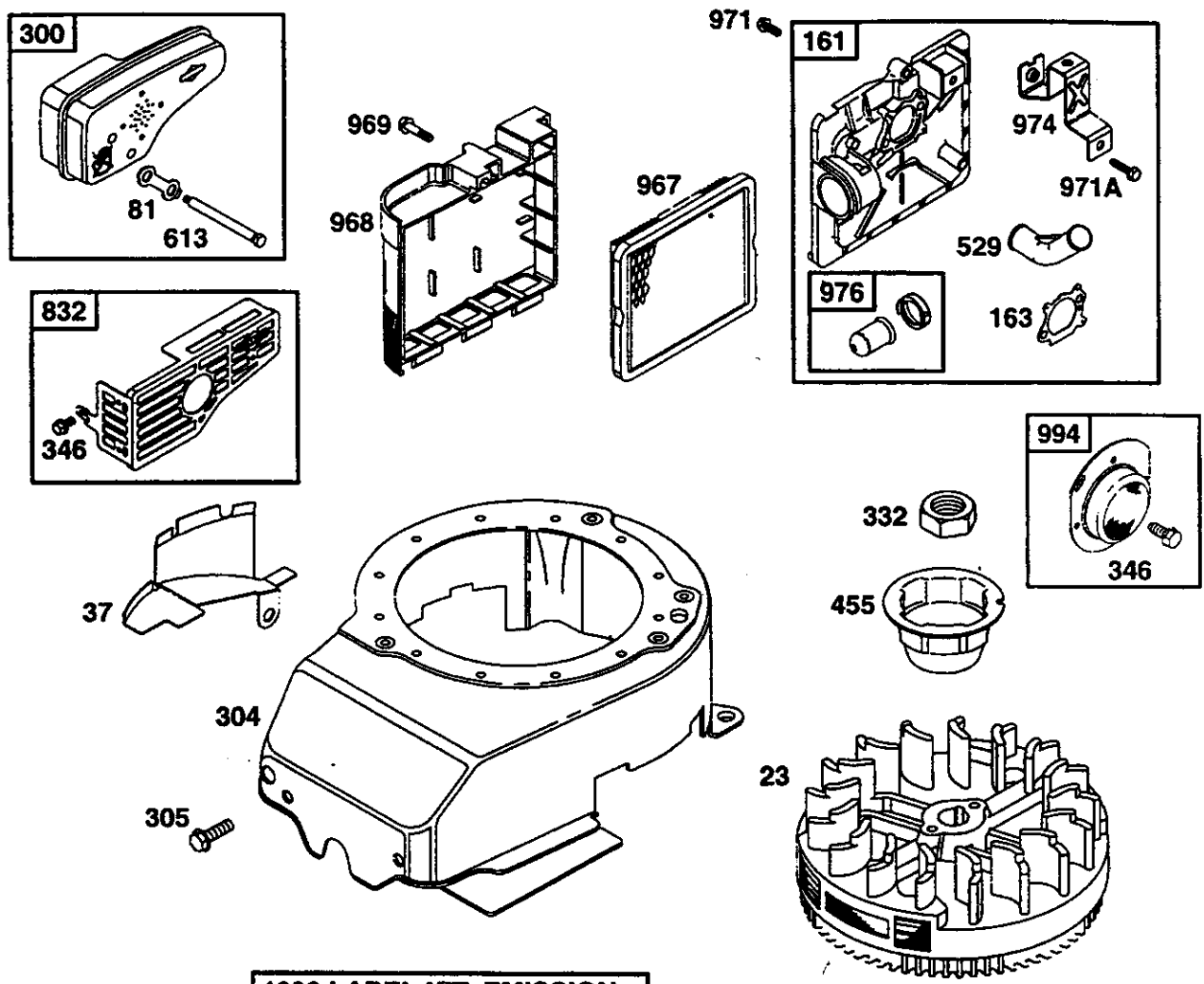

**1036 LABEL KIT-EMISSION**

REF. NO.	PART NO.	DESCRIPTION	REF. NO.	PART NO.	DESCRIPTION	REF. NO.	PART NO.	DESCRIPTION
23	492893	Flywheel	332	92284	Nut-Flywheel	968	281340	Cover-Air Cleaner
37	224511	Guard-Flywheel	346	94602	Screw-Hex.	969	94872	Screw-Slotted Hex.
81	223664	Lock-Muffler Screw	455	225121	Cup-Flywheel	971	94873	Screw-Hex.
161	496116	Base-Air Cleaner	529	281299	Grommet	971A	94749	Screw-Hex.
163	272653	Gasket-Air Cleaner	613	94231	Screw-Shoulder	974	224815	Bracket-Support
300	496106	Muffler-Exhaust	832	494224	Guard-Muffler	976	496115	Primer-Carburetor
304	493294	Housing-Blower	967	491588	Filter-Air	1036	499341	Label Kit-Emission
305	94744	Screw-Hex.				994	398067	Arrester-Spark

★ Included in Gasket Set-Part Number 497316.  
● Included in Carburetor Kit-Part Number 498260.

◆ Included in Carburetor Gasket Set-Part Number 498261.  
∅ Included in Valve Overhaul Gasket Set-Part No. 498528.

**Assemblies include all parts shown in frames.**

**Craftsman 1900 PSI High Pressure Washer 580.768110  
Briggs & Stratton 5HP Quantum, Model 12F802-2407-E2**

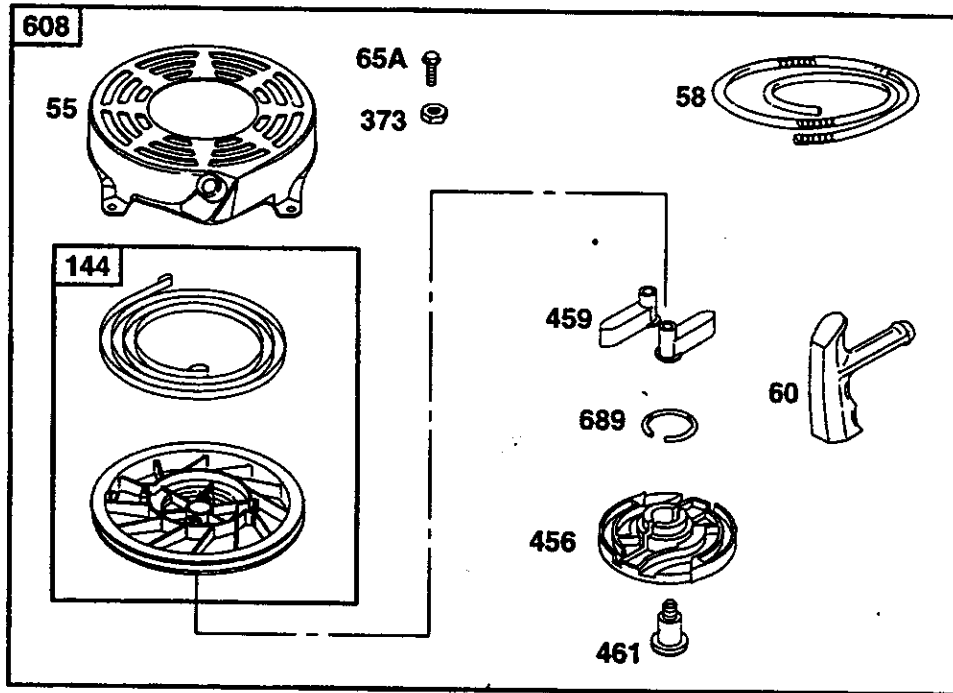

REF. NO.	PART NO.	DESCRIPTION	REF. NO.	PART NO.	DESCRIPTION	REF. NO.	PART NO.	DESCRIPTION
55	497440	Housing-Rewind Starter	60	281434	Grip-Starter Rope	459	281505	Pawl-Ratchet
58	280399	Rope-Starter (Cut To Required Length)	65A	94686	Screw-Hex.	461	94943	Screw-Shoulder
			144	498144	Pulley-Rope Start	608	497680	Starter-Rewind
			373	92987	Nut-Hex.	689	263073	Spring-Friction
			456	281503	Retainer-Spring			

★ Included in Gasket Set-Part Number 497316.  
● Included in Carburetor Kit-Part Number 498260.

◆ Included in Carburetor Gasket Set-Part Number 498261.  
∅ Included in Valve Overhaul Gasket Set-Part No. 498528.

**Assemblies include all parts shown in frames.**

**Craftsman 1900 PSI High Pressure Washer 580.768110  
Briggs & Stratton 5HP Quantum, Model 12F802-2407-E2**

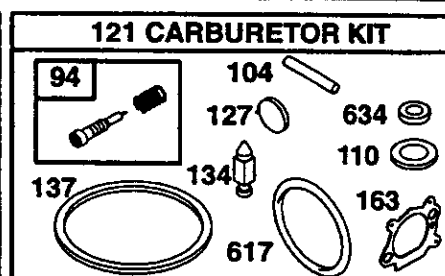
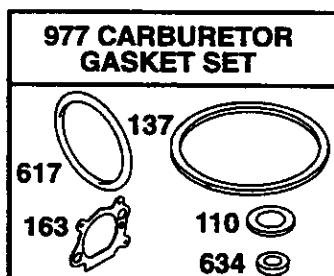
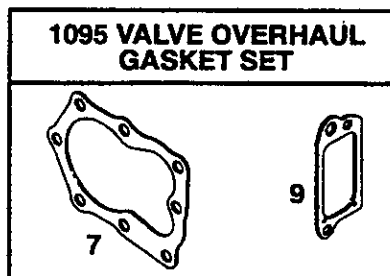
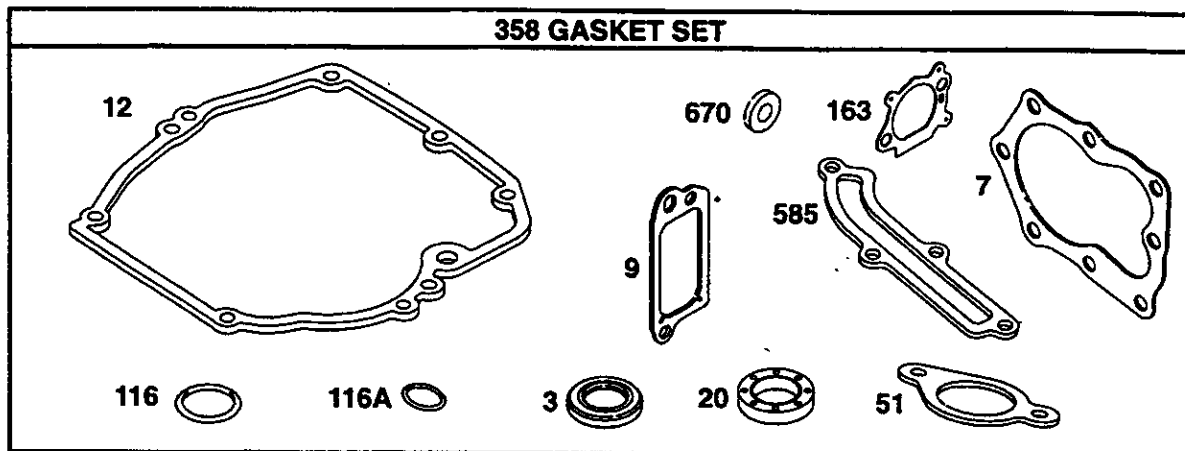

REF. NO.	PART NO.	DESCRIPTION	REF. NO.	PART NO.	DESCRIPTION	REF. NO.	PART NO.	DESCRIPTION
	3	*299819 Seal-Oil		121	498260 Carburetor Kit		617	◆270344 Seal-Intake Manifold
	7	*272916 Gasket-Cylinder Head		127	• Plug-Welch (Sold in Kit Only)		634	◆ Washer-Shaft (Sold in Kit Only)
	9	*272481 Gasket-Breather		134	◆398188 Valve-Needle (Includes Seat)		670	*493823 Spacer (Includes 2)
	12	*272198 Gasket-Crankcase		137	◆ Gasket-Bowl (Sold in Kit Only)		977	498261 Gasket Set- Carburetor
	20	*399781 Seal-Oil		163	*◆272653 Gasket-Air Cleaner		1095	498528 Gasket Set-Valve Overhaul
	51	*272199 Gasket-Intake		358	497316 Gasket Set			
	94	◆493765 Valve-Idle Adjustment		585	*272238 Gasket-Breather Passage			
	104	◆231371 Pin-Float Hinge						
	110	◆ Washer-Bowl (Sold in Kit Only)						
	116	*280393 Seal-O-Ring						
	116A	*280966 Seal-O-Ring						

\* Included in Gasket Set-Part Number 497316.  
● Included in Carburetor Kit-Part Number 498260.

◆ Included in Carburetor Gasket Set-Part Number 498261.  
⊗ Included in Valve Overhaul Gasket Set-Part No. 498528.

**Assemblies include all parts shown in frames.**

**Craftsman 1900 PSI High Pressure Washer 580.768110  
Pump**

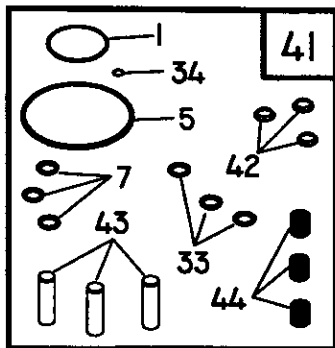
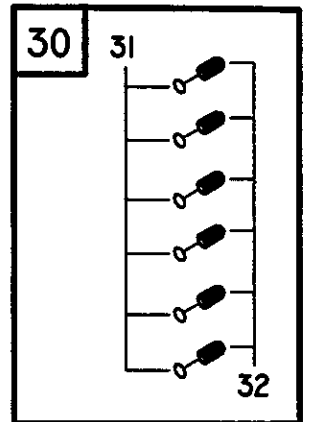
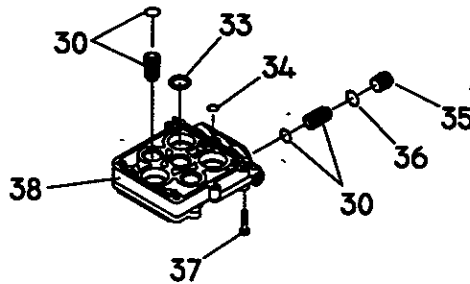
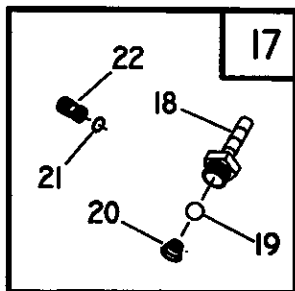
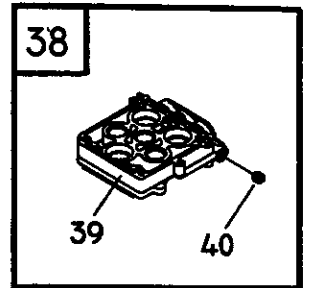
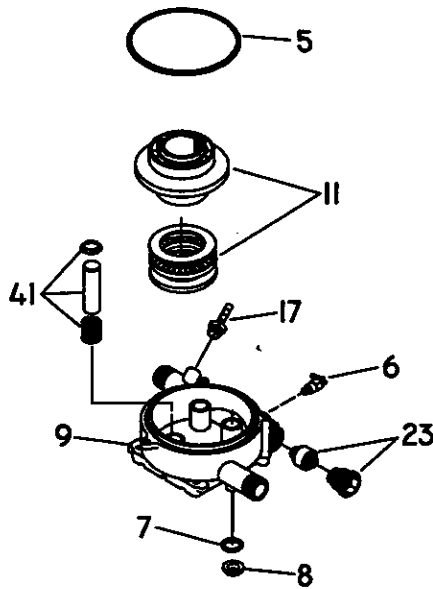
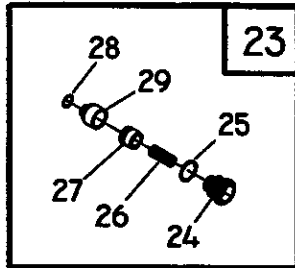
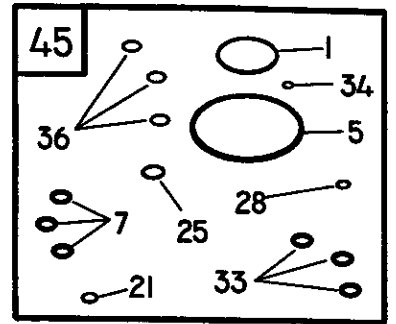
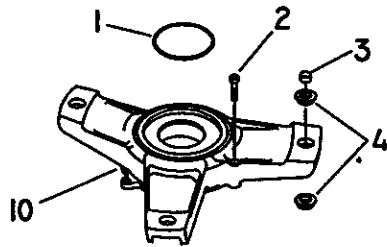
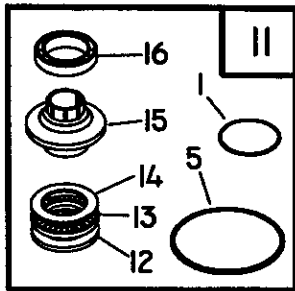



**Craftsman 1900 PSI High Pressure Washer 580.768110  
Pump**

Item	Part #	Qty	Description	Item	Part #	Qty	Description
1	98300	1	SEAL, Engine Donut	28	.....	1	O-RING, .364 ID x .070
2	97962	3	SHCS, M6 - 1 x 25	29	.....	1	SEAT, 2000 Unloader
3	96795	3	SLEEVE, Grommet Spacer	30	B3513	0	KIT, CHECK VALVES
4	21429	6	BUSHING, Rubber Mount	31	.....	6	O-RING, Check Valve
5	97835	1	O-RING, Housing Seal	32	.....	6	ASSY., Check Valve
6	21783	1	THERMAL RELIEF, GPW-EG	33	B3286	3	SEAL, Double-Lip
7	93680	3	SEAL, Oil Piston 15 TC4	34	97837	1	O-RING, Hi-Pressure Transfer
8	97831	3	SPACER, Pilot	35	97841	3	CAP, Outlet Check Valve
9	B2702	1	HOUSING, Piston	36	97840	3	O-RING, Outlet CV Cap
10	98227	1	ADAPTER, Engine	37	40946	4	SHCS, M6-1.0 x 35
11	B2310	0	KIT, AXIAL CAM SERV	38	B4186	0	KIT, HEAD CASTING SFG
12	.....	1	WASHER, Brg. 36 x 65 x 6 Thk	39	.....	1	HEAD, Pump
13	.....	1	ASSY., Brg. Cage 45 x 65	40	.....	1	PLUG, 1/8-28 W/VIRB
14	.....	1	WASHER, Brg. 45 x 65 x 1	41	B2312	0	KIT, PISTON & SPRING
15	.....	1	CAM, Axial 5.6 VS	42	.....	3	RETAINER, Piston Spring
16	.....	1	BALL BEARING, 35 x 72 x 17	43	.....	3	PISTON, Dia. 15 x 65 Lg
17	B3829	0	KIT, CHEM INJECT	44	.....	3	SPRING, Piston Return
18	.....	1	FITTING, Chem Inject	45	B1933	0	KIT, O-RING/SEAL SERV
19	.....	1	BALL, Chem Inject	1	.....	1	SEAL, Engine Donut
20	.....	1	SPRING, Chem Inject	5	.....	1	O-RING, Housing Seal
21	.....	1	O-RING, Venturi	7	.....	3	SEAL, Oil Piston 15 TC4
22	.....	1	VENTURI, Chem Inject	21	.....	1	O-RING, Venturi
23	B3828	0	KIT, UNLOADER	25	.....	1	O-RING, Unloader Cap
24	.....	1	CAP, Unloader	28	.....	1	O-RING, .364ID x .070
25	.....	1	O-RING, Unloader Cap	33	.....	3	SEAL, Double-Lip
26	.....	1	SPRING, 2000 Unloader	34	.....	3	O-RING, Outlet CV Cap
27	.....	1	PISTON, Unloader				

Item numbers 11, 17, 23, 30, 38, 41, and 45 are service kits and include all parts shown within the box. Items previously described are not listed under the service kit number.

**Craftsman 1900 PSI High Pressure Washer 580.768110  
Main Unit**

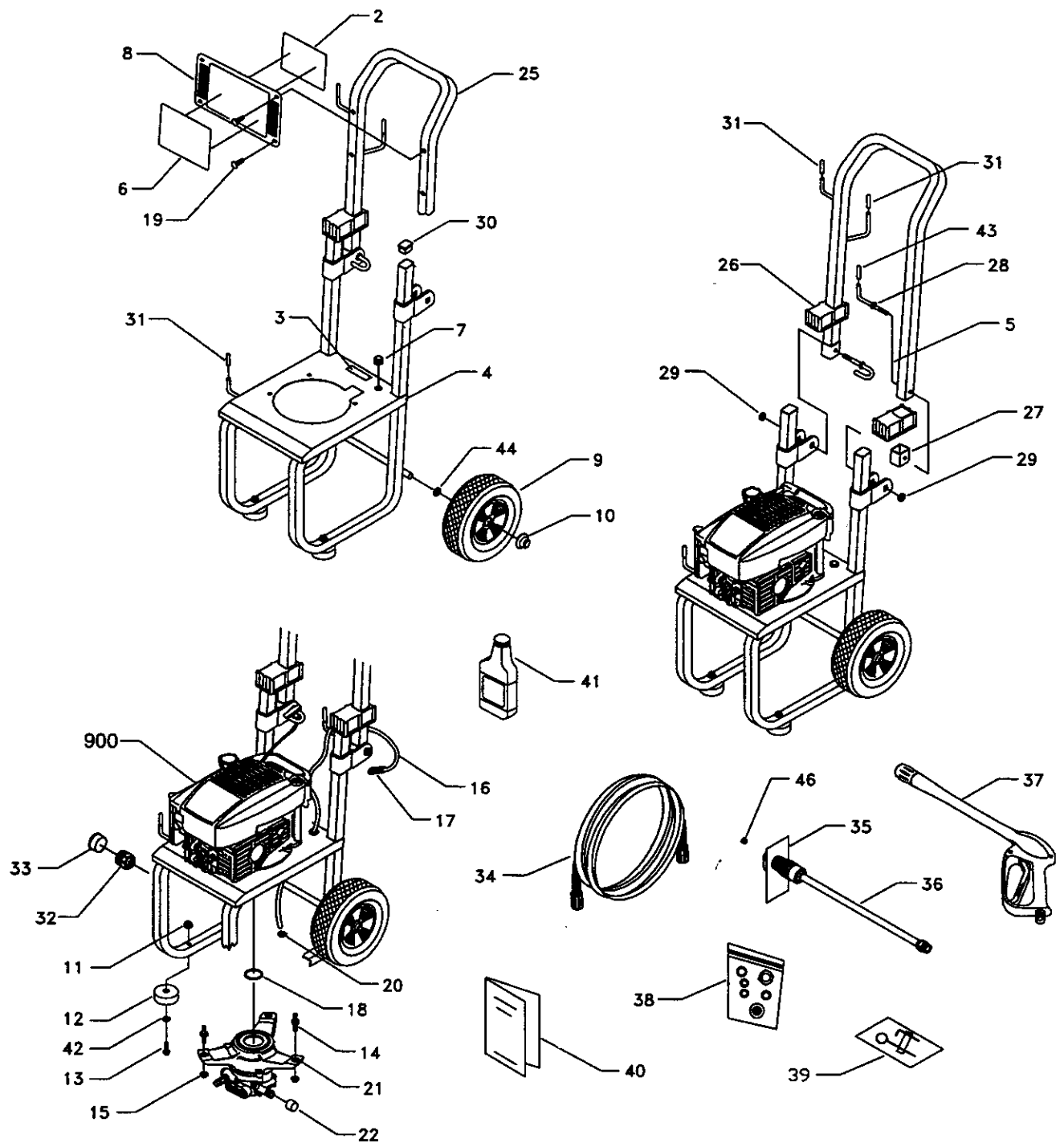

## Craftsman 1900 PSI High Pressure Washer 580.768110

### Main Unit

Item	Part #	Qty	Description
2	B2200	1	DECAL, Instructions
3	96307	1	DECAL, 1-800 Number
4	DB3307	1	BASE, Gray Powder Coated
5	B1730A	1	BOLT, Eye
6	B3777	1	DECAL, 1900 PSI
7	30809	1	GROMMET, Chemical Hose
8	B1786A	1	BILLBOARD
9	21206	2	TIRE, 2" x 8" Black Mag
10	75402	2	PUSHNUT, 1/2"
11	52858	2	NUT, M8 Locking Flange
12	27007	2	MOUNT, Vibration
13	57821	2	HHCS, M8 - 1.25 x 40
14	B1735	3	STUD, Double Ended
15	B1880	3	NUT, with Washer
16	A1040B	1	HOSE, Chemical
17	A1041	1	FILTER, Chemical Hose
18	98300	1	SEAL, Engine Donut
19	B1797	4	FASTENER, Clip
20	48031G	1	CLAMP, Hose 13/16"
21	B3468A	1	ASSY., Pump EG w/Thermal
22	97100	1	CAP, High Pressure
25	DB3330	1	HANDLE, Gray Powder Coated
26	B2791	2	COVER, Hinge
27	B2790	2	CAP, End
28	B2759A	1	HOOK, Chemical Bottle
29	B2071	2	NUT, 1/4-20 Locking Flange
30	81895	2	CAP, Plug
31	B2516	3	CAP, Vinyl
32	21424	1	CONNECTOR, Garden Hose
33	A1408	1	CAP, Hose Connector
34	B3607	1	HOSE, 1/4" x 25'
35	97566	1	TAG, Nozzle Instructions
36	B3335	1	WAND, Adjustable Nozzle
37	B3263	1	GUN, High Pressure
38	B3057	1	KIT, Maintenance
39	B3708	1	KIT, Nozzle, Cleaning
40	B3774	1	MANUAL
41	AB3061B	1	OIL, Engine
42	50190	2	WASHER, M8 Flat
43	B1460	1	CAP, Vinyl
44	49808	2	WASHER, M12 Flat
46	21761	1	NOZZLE, Replacement
900	NSP	1	ENGINE, 5HP

### Optional Accessories Not Illustrated

71-76485	Turbo Nozzle
71-75187	Garden Hose Quick Connect
71-75199	Rotating Brush
71-75197	Accessory Quick Connect
71-75115	Replacement Hose
71-75116	O-Ring Repair Kit
71-76450	25' Extension Hose

# EMISSIONS CONTROL WARRANTY STATEMENT

## **BRIGGS & STRATTON CORPORATION (B&S) , THE CALIFORNIA AIR RESOURCES BOARD (CARB) AND THE UNITED STATES ENVIRONMENTAL PROTECTION AGENCY (U.S. EPA) EMISSION CONTROL SYSTEM WARRANTY STATEMENT (OWNER'S DEFECT WARRANTY RIGHTS AND OBLIGATIONS)**

In the interest of the environment, Briggs & Stratton engines that meet strict emission requirements are labeled, "This engine conforms to 1995-1998 California Emission Control Regulations for ULGE engines and U.S. EPA Phase 1 regulations for small non-road engines." EMISSION CONTROL WARRANTY COVERAGE IS APPLICABLE ONLY TO CERTIFIED ENGINES PURCHASED IN CALIFORNIA IN 1995 AND THEREAFTER WHICH ARE USED IN CALIFORNIA AND TO CERTIFIED MODEL YEAR 1997 AND LATER ENGINES WHICH ARE PURCHASED AND USED ELSEWHERE IN THE UNITED STATES.

### **California and United States Emission Control Defects Warranty Statement**

CARB, U.S. EPA and B&S are pleased to explain the Emission Control System Warranty Statement on your 1996 and later utility or lawn and garden equipment (ULGE) engine. In California, new ULGE engines produced on or after August 1, 1995 must be designed, built and equipped to meet the State's stringent anti-smog standards. Elsewhere in the United States, new non-road, spark-ignition engines certified for model year 1997 and alter, must meet similar standards set forth by the U.S. EPA. B&S must warrant the emission control system on your engine for the periods of time listed below provided there has been no abuse, neglect or improper maintenance of your ULGE engine.

Your emission control system includes parts such as the carburetor, air cleaner, ignition system, muffler and catalytic converter. Also included may be connectors and other emission related assemblies. Where a warrantable condition exists, B&S will repair your ULGE engine at no cost to you including diagnosis, parts and labor.

### **Briggs and Stratton Emission Control Defects Warranty Coverage**

ULGE engines are warranted relative to emission control parts defects for a period of two years, subject to the provisions set forth below. If any covered part on your engine is defective, the part will be repaired and replaced by B&S.

### **Owner's Warranty Responsibilities**

As the ULGE engine owner you are responsible for the performance of the required maintenance listed in your Operator/Owner Manual. B&S recommends that you retain all of your receipts covering maintenance on your ULGE engine, but B&S cannot deny warranty solely for the lack of receipts or for your failure to ensure the performance of all scheduled maintenance.

As the ULGE engine owner, you should however be aware that B&S may deny you warranty coverage if your ULGE engine or a part has failed due to abuse, neglect, improper maintenance or unapproved modifications.

You are responsible for presenting your ULGE engine to an Authorized B&S Service Dealer as soon as a problem exists. The undisputed warranty repairs should be completed in a reasonable amount of time, not to exceed 30 days.

If you have any questions regarding your warranty rights and responsibilities, you should contact a B&S Service Representative at 1-414-259-5262.

The emission warranty is a defects warranty. Defects are judged on normal engine performance. The warranty is not related to an in-use emission test.

## **BRIGGS AND STRATTON EMISSION CONTROL DEFECTS WARRANTY PROVISIONS**

The following are specific provisions relative to your Emissions Control Defects Warranty Coverage. It is in addition to the B&S engine warranty for non-regulated engines found in the Operator/Owner's Manual.

### **1. Warranted Parts**

Coverage under this warranty extends only to the parts listed below (the emission control systems parts) to the extent these parts were present on the engine purchased.

#### **a. Fuel Metering System**

- Cold start enrichment system (soft choke)
- Carburetor and internal parts
- Fuel Pump

#### **b. Air Induction System**

- Air cleaner
- Intake manifold

#### **c. Ignition system**

- Spark Plugs
- Magneto ignition system

#### **d. Catalyst System**

- Catalyst converter
- Exhaust manifold
- Air injection system or pulse valve

#### **e. Miscellaneous Items Used in Above Systems**

- Vacuum, temperature, position, time sensitive valves and switches
- Connectors and Assemblies

### **2. Length of Coverage**

B&S warrants to the initial owner and each subsequent purchaser that the Warranted Parts shall be free from defects in materials and workmanship which caused the failure of the Warranted Parts for a period of two years from the date the engine is delivered to a retail purchaser.

### **3. No Charge**

Repair or replacement of any Warranted Part will be performed at no charge to the owner, including diagnostic labor which leads to the determination that a Warranted Part is defective, if the diagnostic work is performed at an Authorized B&S Service Dealer. For emissions warranty service contact your nearest Authorized B&S Dealer as listed in the "Yellow Pages" under "Engines, Gasoline," "Gasoline Engines," "Lawn Mowers" or similar category.

### **4. Claims and Coverage Exclusions**

Warranty claims should be filed in accordance with the provisions of the B&S Engine Warranty Policy. Warranty coverage shall be excluded for failures of Warranted Parts which are not original B&S parts or because of abuse, neglect or improper maintenance as set forth in the B&S Engine Warranty Policy. B&S is not liable to cover failures of Warranted Parts caused by the use of add-on, non-original, or modified parts.

### **5. Maintenance**

Any Warranted Part which is not scheduled for replacement as required by maintenance or which is scheduled only for regular inspection to the effect of "repair or replace as necessary" shall be warranted as to defects for the warranty period.

Any Warranted part which is scheduled for replacement as required by maintenance shall be warranted as to defects only for the period of time up to the first scheduled replacement for that part. Any replacement part that is equivalent in performance and durability may be used in the performance of any maintenance or repairs. The owner is responsible for the performance of all required maintenance, as defined in the B&S Operator/Owner Manual.

### **6. Consequential Coverage**

Coverage here under shall extend to the failure of any engine components caused by the failure of any Warranted Part still under warranty.

**For in-home major brand repair service:**

Call 24 hours a day, 7 days a week

**1-800-4-MY-HOME<sup>SM</sup>** (1-800-469-4663)

**Para pedir servicio de reparación a domicilio – 1-800-676-5811**

In Canada for all your service and parts needs call – **1-800-665-4455**  
Au Canada pour tout le service ou les pièces

**For the repair or replacement parts you need:**

Call 7 am – 7 pm, 7 days a week

**1-800-366-PART** (1-800-366-7278)

**Para ordenar piezas con entrega a domicilio – 1-800-659-7084**

**For the location of a Sears Parts and Repair Center in your area:**

Call 24 hours a day, 7 days a week

**1-800-488-1222**

**For information on purchasing a Sears Maintenance Agreement  
or to inquire about an existing Agreement:**

Call 9 am – 5 pm, Monday – Saturday

**1-800-827-6655**



The Service Side of Sears™