



# PRO 750 Conventional TREADMILL

MODEL NO. \_\_\_\_\_

SERIAL NO. \_\_\_\_\_

The Model and Serial numbers are located on frame just below the motor hood cover. Please write down these numbers in the spaces provided above for future reference.

## QUESTIONS?

**DO NOT RETURN** this product to the store where purchased.

**CALL OUR TOLL FREE HELPLINE**

USA: (888) 340-0482  
Canada: (800) 897-6025

## CAUTION!

Please read the precautions and instructions in this manual before using this equipment. Please save this manual for future reference.



# OWNER'S MANUAL

**KEYS FITNESS PRODUCTS, LP**  
11220 Petal Street  
Dallas, Texas 75238

**MADE IN U.S.A.**

**KEYS FITNESS PRODUCTS, LP - LIMITED WARRANTY**

**PLEASE CONSULT YOUR PHYSICIAN BEFORE USING THIS PRODUCT.**

This Limited Warranty applies in the United States, Canada, and Mexico to products manufactured or distributed by Keys Fitness Products, LP ("Keys") under the Keys brand name. The warranty period to the original purchaser is (lifetime) on the frame, (1) year on the motor, (1) year on parts, and (1) year labor.

Keys warrants that the Product you have purchased for non-commercial, personal, family, or household use from Keys or from an authorized Keys reseller is free from defects in materials or workmanship under normal use during the warranty period. Your sales receipt, showing the date of purchase of the Product, is your proof of the date of purchase. This warranty only extends to you, the original purchaser. It is not transferable to anyone who subsequently purchases the Product from you. It excludes expendable parts. This Limited Warranty becomes VALID ONLY if the treadmill is assembled/installed by a Keys Fitness authorized dealer/technician unless otherwise authorized by Keys Fitness in writing (if anyone other than a Keys Fitness authorized dealer/technician assembles a Keys Fitness treadmill the warranty will be void unless accompanied by written authorization by Keys Fitness).

During the warranty period Keys will at no additional charge, repair or replace (at Keys' option) the product if it becomes defective, malfunctions, or otherwise fails to conform with this Limited Warranty under normal non-commercial, personal, family or household use. In repairing the Product, Keys may replace defective parts, or at the option of Keys, serviceable used parts that are equivalent to new parts in performance. All exchanged parts and Products replaced under this warranty will become the property of Keys. Keys reserves the right to change manufacturers of any part to cover any existing warranty.

To obtain warranty service, you must contact a Keys authorized service technician or Keys Fitness at our phone numbers located in this manual. Any parts determined to be defective must be returned to Keys to obtain warranty service. You must prepay any shipping charges, export taxes, custom duties and taxes, or any other charges associated with transportation of the parts or Product. In addition, you are responsible for insuring any parts or Product shipped or returned. You assume the risk of loss during shipment. You must present Keys with proof-of-purchase documents (including the date of purchase). Any evidence of alteration, erasing or forgery of proof-of-purchase documents will be cause to void this Limited Warranty.

This warranty does not extend to any product not purchased from Keys or from an authorized Keys reseller. This Limited Warranty does not extend to any Product that has been damaged or rendered defective; (a) as a result of accident, misuse, or abuse; (b) by the use of parts not manufactured or sold by Keys; (c) by modification of the Product or normal wear and tear; (d) operation on incorrect power supplies; or (e) as a result of service by anyone other than Keys, or an authorized Keys warranty service provider. Product on which the serial number has been defaced or removed is not eligible for warranty service. Should any Product be submitted for warranty service be found ineligible therefore, an estimate of repair cost will furnished and the repair will be made if requested by you upon Keys' receipt of payment or acceptable arrangements for payment.

EXCEPT AS EXPRESSLY SET FORTH IN THIS WARRANTY, KEYS MAKES NO OTHER WARRANTIES, EXPRESSED OR IMPLIED, INCLUDING ANY IMPLIED WARRANTIES OF MERCHANTABILITY AND FITNESS FOR A PARTICULAR PURPOSE. KEYS EXPRESSLY DISCLAIMS ALL WARRANTIES NOT STATED IN THIS LIMITED WARRANTY. ANY IMPLIED WARRANTIES THAT MAY BE IMPOSED BY LAW ARE LIMITED TO THE TERMS OF THIS LIMITED WARRANTY. NEITHER KEYS NOR ANY OF ITS AFFILIATES SHALL BE RESPONSIBLE FOR INCIDENTAL OR CONSEQUENTIAL DAMAGES. SOME STATES DO NOT ALLOW LIMITATIONS ON HOW LONG AN IMPLIED WARRANTY LASTS OR THE EXCLUSION OR LIMITATION OF INCIDENTAL OR CONSEQUENTIAL DAMAGES, SO THE ABOVE LIMITATIONS OR EXCLUSION MAY NOT APPLY TO YOU. This Limited Warranty gives you specific legal rights and you may also have other rights that may vary from state to state. This is the only express warranty applicable to Keys-branded products. Keys neither assumes nor authorizes anyone to assume for it any other express warranty.

PLEASE SEND IN THE ATTACHED WARRANTY CARD WITHIN TEN (10) DAYS OF PURCHASE TO REGISTER YOUR TREADMILL WITH KEYS FITNESS PRODUCTS, LP.

**WARRANTY REGISTRATION**

A. FIRST NAME INITIAL LAST NAME  
 \_\_\_\_\_  
 STREET APT. NO.  
 \_\_\_\_\_  
 CITY STATE ZIP  
 \_\_\_\_\_  
 Phone \_\_\_\_\_

NOTE The model number is found on the front of the Owner's Manual

MODEL NO. \_\_\_\_\_  
 SERIAL NO. \_\_\_\_\_

NOTE The serial number is found on the ET sticker located on the front of the treadmill.

DATE OF PURCHASE \_\_\_\_\_

<p>B. What store or catalog did you purchase this product?                  _____</p>	<p>F. How did you learn of this product?  <input type="checkbox"/> TV <input type="checkbox"/> Friend  <input type="checkbox"/> Radio <input type="checkbox"/> Print ad/flyer  <input type="checkbox"/> In store display <input type="checkbox"/> Other  <input type="checkbox"/> Salesperson _____</p>	<p>I. How important are each of the following features:                  Least Most                  Speed <input type="checkbox"/> <input type="checkbox"/> <input type="checkbox"/> <input type="checkbox"/> <input type="checkbox"/>                  Horsepower <input type="checkbox"/> <input type="checkbox"/> <input type="checkbox"/> <input type="checkbox"/> <input type="checkbox"/>                  Warranty <input type="checkbox"/> <input type="checkbox"/> <input type="checkbox"/> <input type="checkbox"/> <input type="checkbox"/>                  Price <input type="checkbox"/> <input type="checkbox"/> <input type="checkbox"/> <input type="checkbox"/> <input type="checkbox"/>                  Features <input type="checkbox"/> <input type="checkbox"/> <input type="checkbox"/> <input type="checkbox"/> <input type="checkbox"/></p>
<p>C. How do you plan to use this product?  <input type="checkbox"/> Run <input type="checkbox"/> Walk <input type="checkbox"/> Both</p>	<p>G. Why did you buy a treadmill?  <input type="checkbox"/> Dr.'s Orders <input type="checkbox"/> Improve cardiovascular fitness  <input type="checkbox"/> Lose weight <input type="checkbox"/> In home convenience/safety  <input type="checkbox"/> Firm up <input type="checkbox"/> In home convenience/safety  <input type="checkbox"/> Other _____</p>	<p>Other comments or suggestions:                  _____                  _____                  _____                  _____</p>
<p>D. Sex of purchaser:  <input type="checkbox"/> Male <input type="checkbox"/> Female</p>	<p>H. Why did you choose our product?  <input type="checkbox"/> Speed Range <input type="checkbox"/> Look/Design  <input type="checkbox"/> Horsepower <input type="checkbox"/> Safety  <input type="checkbox"/> Warranty <input type="checkbox"/> Brand  <input type="checkbox"/> Price <input type="checkbox"/> Durability</p>	

# PRO 750 Conventional Treadmill

## OWNER'S MANUAL



---

### TABLE OF CONTENTS      PAGE

Warranty card	2-3
Important safety information	4-5
Before you start	5
Assembly instructions	6
How to plug in the power cord	7
Console functions	8
Console descriptions	9
Program profiles	10
Operating instructions	11
Maintenance instructions	12
Belt adjustments and tension	13
Calibration to MPH or Km/H	14
Troubleshooting guide	15
Exercise guide	16
Exploded View and parts list	17
Contacting customer service (back cover)	Back Cover

# Important Safety Information

## WARNING!

- 1) Before using this treadmill or starting any exercise program, consult your physician. This is especially important for persons over the age of 35 and/or persons with pre-existing health problems. Keys Fitness Products LP assumes no responsibility for personal injury or property damage sustained by or through the use of this product.
- 2) To reduce the risk of electrical shock, burns, fire, or other possible injuries to the user, it is important to review this manual and the following precautions *before* operation.

## SAFETY PRECAUTIONS AND TIPS

- It is the owner's responsibility to ensure that all users of this treadmill have read the Owner's Manual and are familiar with warnings and safety precautions.
- This treadmill has a user maximum capacity of 250 pounds.
- The treadmill should only be used on a level surface and is intended for indoor use only. The treadmill should not be placed in a garage, patio, or near water and should never be used while you are wet. Keys recommends a treadmill mat be placed under the treadmill to protect floor or carpet and for easier cleaning.
- Follow safety information in regards to plugging in your treadmill. Keep the power cord away from the incline wheels and do not run the power cord underneath your treadmill. Do not operate the treadmill with a damaged or frayed power cord.
- Wear comfortable, good-quality walking or running shoes and appropriate clothing. Do not use the treadmill with bare feet, sandals, socks or stockings!
- Always straddle the belt and allow it to start moving before stepping onto the belt.
- Hold on to handrails when adjusting speed, incline, or other controls.
- Always examine your treadmill before using to ensure all parts are in working order.
- Allow the belt to fully stop before dismounting.
- Pets should be never be allowed near or on the treadmill.
- Do not leave children unsupervised near or on the treadmill.
- Never operate the treadmill where oxygen is being administered, or where aerosol products are being used.
- Never insert any object or body parts into any opening.
- For safety and to prevent damage to your treadmill, no more than one person should be allowed to use the treadmill at a time.

- Always unplug the treadmill before cleaning and/or servicing. Service to your treadmill should only be performed by an authorized service representative, unless authorized and/or instructed by a Keys treadmill technician. Failure to follow these instructions will void the treadmill warranty.
  - Never leave the treadmill unattended while it is running.
- 

## **Before You Start**

Thank you for purchasing a Keys treadmill! This quality product you have chosen was designed to meet your needs for cardiovascular exercise.

- Before you start, please read the Owner's Manual and become familiar with the operation of your new treadmill.
- Do not stand on the walking belt while pressing the Power button or Start/Stop button.
- Always adjust the speed of the treadmill in small increments as this treadmill is capable of high speeds.
- If you are taking medication, consult your physician to see if the medication will affect your exercise heart rate.
- If you have heart problems, you are not active, and/or are over the age of 50 years, do not use the pre-set treadmill programs or start an exercise program without first contacting a getting approval from your physician.
- To avoid the risk of electrical shock, always keep the console dry. Do not spill liquids on the console. Keys recommends a sealed water bottle for beverages consumed while using the treadmill.

# Assembly Instructions

Keys 750 treadmills are shipped in one piece to make assembly very easy. The following steps should be followed for assembling the treadmill:

Remove any packing materials from the treadmill. Do not throw away any packing materials until assembly is completed.

Place the base on a clean, level surface. Make sure the electrical cord will easily reach an electrical outlet.

1. Raise the console into an upright position and have someone hold in position.
2. Insert TUBE SPACER from the bottom of the upright tube and line up with bottom hole. Hold TUBE SPACER while installing 1 1/2" x 5/16" button head bolt. SPACERS MUST BE USED. Repeat for other side. Tighten all bolts with allen wrench.
3. Install handlebars with 2 bolts for each side by sliding the handlebar mounting tabs down into upright tube. Line up holes and install 1" x 5/16" button head bolts on the front and rear sides of the upright. Tighten securely with allen wrench.
4. Be sure that the treadmill is level to the floor. Assembly is now complete!

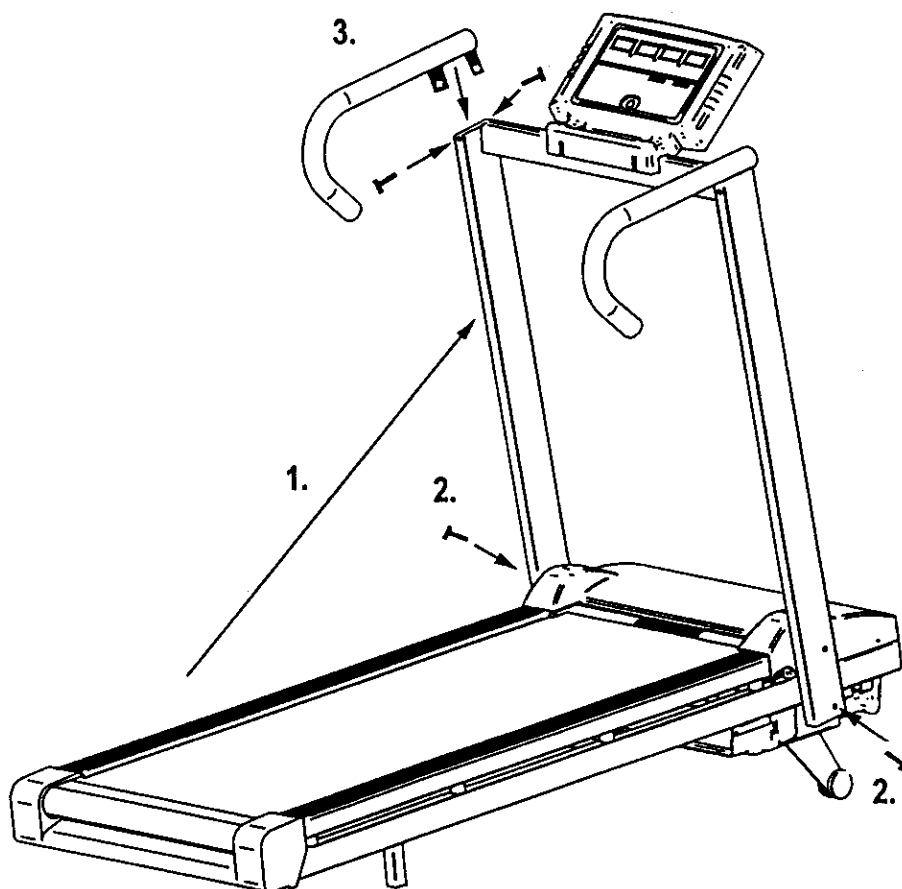

# How to Plug in the Power Cord

## WARNING!

IMPROPER CONNECTION OF THE EQUIPMENT GROUNDING CONNECTOR CAN RESULT IN A RISK OF AN ELECTRIC SHOCK. CHECK WITH A QUALIFIED ELECTRICIAN OR SERVICE MAN IF YOU ARE IN DOUBT AS TO WHETHER THE PRODUCT IS PROPERLY GROUNDING. DO NOT MODIFY THE PLUG PROVIDED WITH THE PRODUCT, IF IT WILL NOT FIT THE OUTLET, HAVE A PROPER OUTLET INSTALLED BY A QUALIFIED ELECTRICIAN.

This treadmill can be seriously damaged by sudden voltage changes in your home's electrical power. Voltage spikes, surges, and noise interference can result from weather conditions or from other appliances being turned on or off. To reduce the possibility of treadmill damage, always use a surge protector (not included) with your treadmill.

Surge protectors can be purchased at most hardware stores. Keys recommends a single outlet surge protector with a UL 1449 rating as a Transient Voltage Surge Suppressor (TVSS) with a UL suppressed voltage rating of 400V or less and an electrical rating of 120VAC, 15 amps.

This treadmill must be grounded to reduce the risk of electrical shock. Grounding provides a path of least resistance for electric current, should the treadmill malfunction. The Keys treadmill comes with an electrical cord having an equipment-grounding conductor and a grounding plug. Always plug the power cord into a surge protector, and plug the surge protector into an appropriate outlet that is properly installed and grounded in accordance with all local codes and ordinances.

This product is for use on a nominal 120-volt circuit, and has a grounding plug that looks like the plug illustrated in the drawing (1) below. A temporary adapter shown below (2) can be used to connect the surge protector to a 2-pole receptacle if a properly grounded outlet is not available. This temporary adapter should only be used until a properly grounded outlet (3-pole) receptacle can be installed by a qualified electrician.

The green colored lug or equivalent extending from the adapter must be connected to a permanent ground such as a properly grounded outlet box cover. Whenever the adapter is used, it must be held in place by a metal screw. Some 2-pole receptacle outlet box covers are not grounded. Contact a qualified electrician to insure the outlet box cover is grounded before using an adapter.

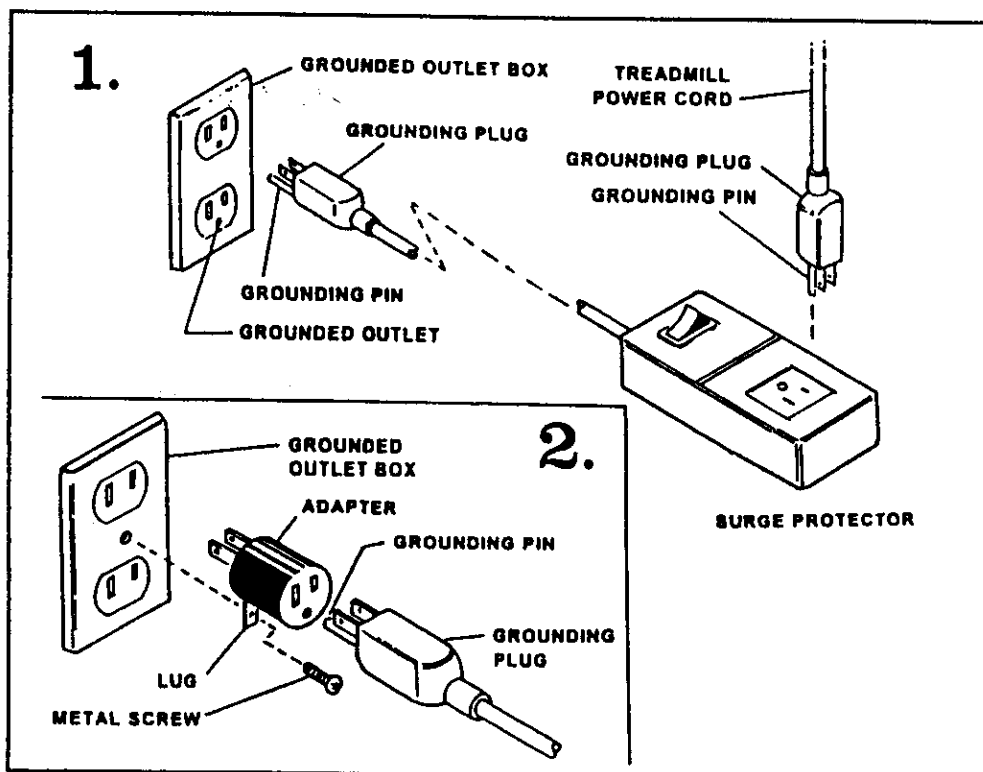

# Console Functions

There are four display windows on the control panel to provide you with vital feedback information.

## TIME WINDOW

- **TIME:** Indicates elapsed time after pressing start in minutes and seconds (0-99 minutes, 0-59 seconds)
- **INTERVAL TIME:** Indicates countdown in seconds to the next interval starting at 5 seconds and counting to 0 seconds

## SPEED WINDOW

- **SPEED:** Indicates MPH (miles per hour) or KMH (kilometer per hour) in .1 increments

## DISTANCE/CALORIES WINDOW

- **DISTANCE:** Indicates Miles or Kilometers traveled in .01 increments up to 9.99 and .1 increments starting at 10.0
- **CALORIES:** Indicates estimated calories used based on 150 lb. person at the indicated speed, incline, and time

## INCLINE WINDOW

- **INCLINE:** Indicates incline in percent of grade 0-15% in .5 increments



# Console Descriptions

**MODE BUTTON** – Accesses Programs for Fat Burn, Cardio, or Warm Up, Press once for Program, or twice for P1 or press three times for P2.

The **PAUSE** button pauses (stops) the treadmill while it is in operation. The Pause button also works as a re-start button after treadmill has Paused. The Pause button also functions as a re-set button for previously programmed P1 and P2 programs. **CAUTION:** When re-starting with the Pause button, treadmill will resume previous speed prior to pausing.

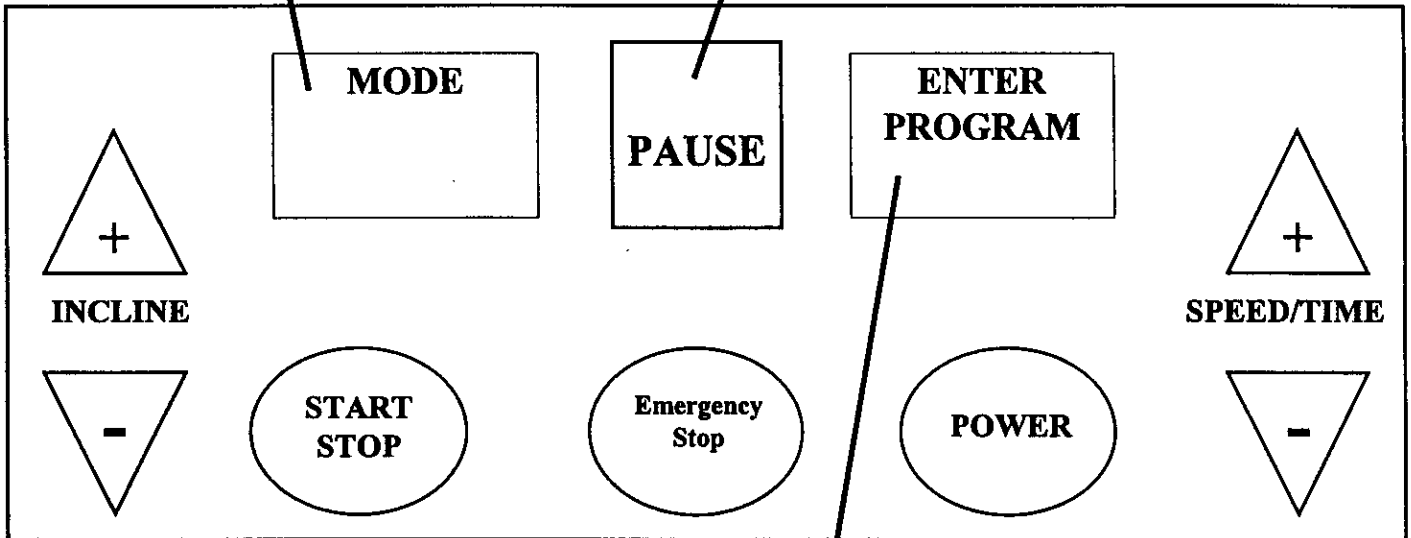

**INCLINE +/-** buttons increase (+) or Decrease (-) incline (percent of grade)

The **START/STOP** button puts the treadmill in motion. Will also Stop treadmill while in motion, reverting treadmill to original start up mode.

**ENTER PROGRAM** Button-  
To enter a program, make your selection by pressing the **MODE** Button. The Time window will then blink. After selecting time, press the **ENTER PROGRAM** button to set. Follow the same procedure for desired speed and incline.

**POWER** button  
Turns on Power to Console.

**SPEED +/-** buttons increase (+) or decrease (-) speed and time in programming mode.

# Program Profiles

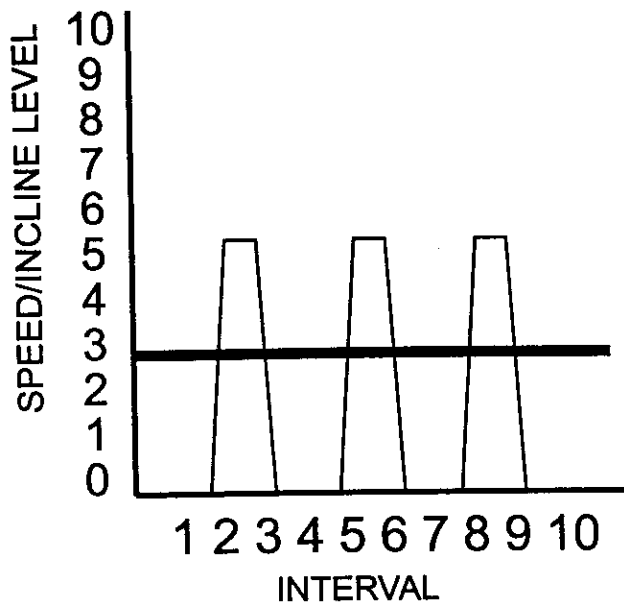

**FAT BURN PROGRAM**  
 Constant Speed throughout program,  
 with Incline changes on alternating  
 intervals.

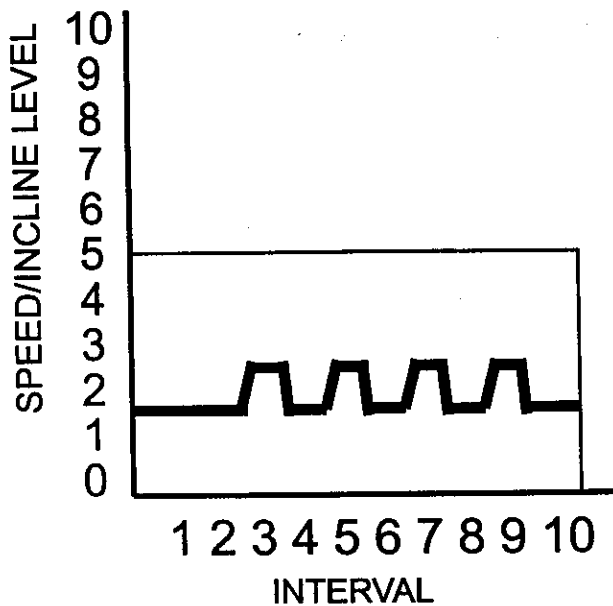

**CARDIO PROGRAM**  
 Constant Incline throughout program,  
 with Speed changes on alternating  
 intervals.

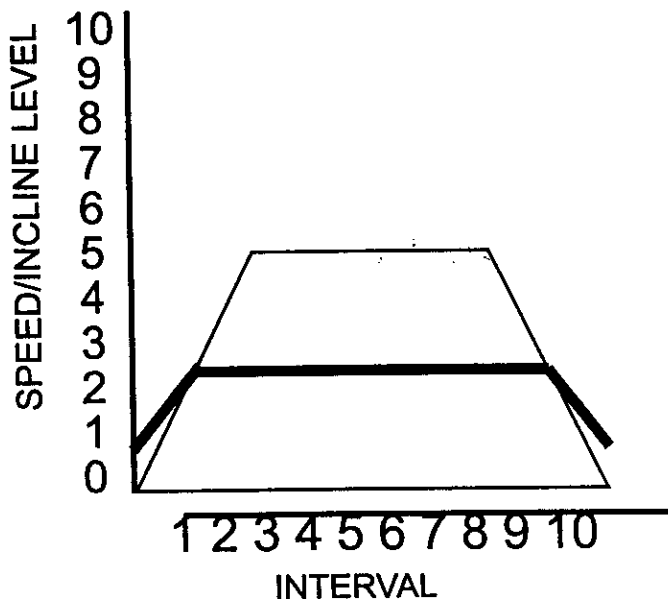
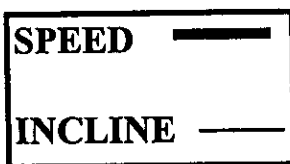

**WARM UP PROGRAM**  
 Gradual Speed and Incline increase to  
 plateau, ending with gradual decrease  
 in Speed and Incline.

---

# Operating Instructions

## QUICK START / MANUAL MODE

- Plug into a standard wall outlet (110 Volt AC, 15 amp circuit)
- Stand on the treadmill and straddle belt.
- Press POWER button. There will be an eight (8) second delay after pressing the POWER button before data can be entered. The TIME window will flash.
- Press START/STOP button. Belt will begin to move after 4 seconds. Step on belt slowly after the belt starts moving. Speed or incline may be adjusted by using the appropriate + (increase) or – (decrease) buttons.
- To end your workout, press START/STOP button. Belt will gradually slow to zero.
- To pause your workout, press PAUSE.
- To re-start after pausing: Press the PAUSE button. **WARNING:** The treadmill belt will resume at the speed the treadmill was moving before pausing.
- **Countdown Time, Preset Speed and/or Incline:** Time, Speed, and Incline may be preset prior to getting started. After pressing the POWER button, the time window will blink. Use the SPEED/TIME + or – arrows to select your workout time, then press the ENTER PROGRAM button. The SPEED/TIME window will now be flashing. Using the same + or – arrows, select the speed for your workout, then press ENTER PROGRAM. Now the INCLINE window will be flashing. Use the INCLINE + or – arrows to set your workout incline, then press ENTER PROGRAM. To start, press the START/STOP button.

## PROGRAM MODE

- Plug into a standard wall outlet (110 Volt AC, 15 amp circuit)

- Stand on the treadmill and straddle belt.
- Press POWER button. There will be an eight (8) second delay after pressing the POWER button before data can be entered. The TIME window will flash.
- There are three (3) preset programs to choose from: Fat Burn, Cardio, and Warm Up (see the program profiles later in this manual). Select the MODE button and the light above the program name on the console will light up and an "OP" will be displayed in the Calories window. Continue to press the MODE button for the desired program.
- Press START/STOP button. Belt will begin to move after 4 seconds. Step on belt slowly after the belt starts moving.
- **Customizing programs in P1 and P2 Mode:** Each pre-set program can be customized in the P1 or P2 mode. The P1 and P2 modes allow you to save the information for future use. After making the program selection, the CALORIES window will read "OP." "OP" refers to "original program" and is pre-set. Press the MODE button once more, and the CALORIE window will read P1. The "P1" mode is now accessed. You can now program the Time, Speed, and Incline in P1 mode, which will save your entered information for future use. The time window will blink. Use the SPEED/TIME + or – arrows to select your workout time, then press the ENTER PROGRAM button. The SPEED/TIME window will now be flashing. Using the same + or – arrows, select the speed for your workout, then press ENTER PROGRAM. Now the INCLINE window will be flashing. Use the INCLINE + or – arrows to set your workout incline, then press ENTER PROGRAM. To start, press the START/STOP button. To access P2 mode, press the MODE until the P2 shows in the CALORIE window for your selected program. Follow the above procedure to customize. **PLEASE NOTE:** Once you have programmed the P1 or P2 modes, you will need to use the PAUSE button to change the program you previously entered.

# Maintenance Instructions

**WARNING! Before performing any maintenance to your treadmill, always unplug the power cord from the surge protector.**

## DECK LUBRICATION INSTRUCTIONS

The treadmill deck has been pre-lubricated at the factory. For optimal deck life and performance, the deck should be checked periodically for lubrication. Keys recommends checking the deck every 30 days or 30 hours of operation (See Diagram below). Lift the edge of the belt and feel the top of the deck, reaching as far to the center as possible. If it feels slick, then no further lubrication is required. If it feels dry to the touch, lubrication is required. Keys recommends NAPA 8300 silicone or Pyroil Silicone Lubricant, available at most auto parts and/or hardware stores. Follow the directions here for applying silicone:

**TO APPLY LUBRICANT TO THE WALKING BOARD:**

- 1) Position the belt so that the seam is located on top and in the center of walking board.
- 2) Insert the red spray extension tube (included with silicone spray) into silicone spray nozzle.
- 3) Lift the edge of the belt and position the red extension tube approximately 6" from the front of the belt. Apply silicone lubricant to the deck moving from the front towards the rear. Note: Spray time should not exceed 4 seconds. Repeat for the other side of the deck. **WARNING! DO NOT over lubricate the deck. Any excess lubricant should be wiped off immediately. Do not spray silicone lubricant inside the motor compartment.**
- 4) After application, allow the silicone to penetrate for approximately one minute.
- 5) To help spread the silicone, turn the treadmill on to 2 miles per hour and walk on all surface areas. Lubrication is complete!

## CLEANING

Routine cleaning of your Keys treadmill will extend the life of your treadmill. **WARNING!** To prevent electrical shock, be sure the power to the treadmill is OFF and the unit unplugged from the wall electrical outlet before attempting any cleaning or maintenance.

**AFTER EACH WORKOUT:** Wipe off the console and other treadmill surfaces with a clean, water dampened soft cloth to remove excess perspiration. **USE NO CHEMICALS.**

**WEEKLY:** Use of a treadmill mat is recommended for ease of cleaning. Dirt from your shoes contacts the belt and eventually makes it to underneath the treadmill. Vacuum underneath treadmill once a week.

**DO NOT CLEAN OR WIPE UNDERNEATH THE BELT!**

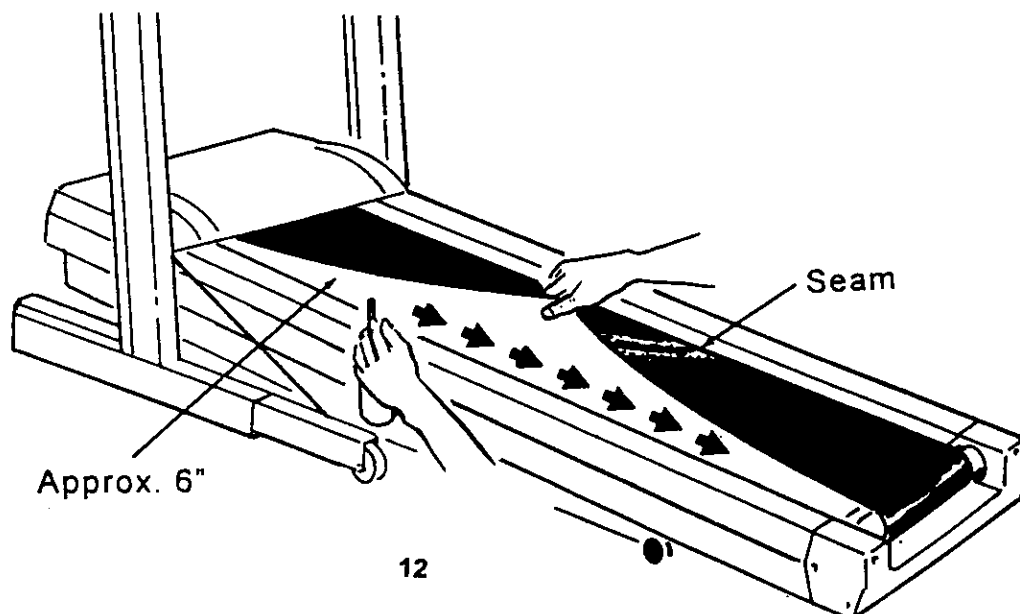

# Belt Adjustment and Tension

Belt adjustment and tension performs two functions: adjustment for tension and centering. Your new treadmill comes pre-adjusted from the factory for tension and centering. Please follow the procedures below if the belt shifts left or right or if the belt slips while walking:

## WALKING BELT HAS SHIFTING TO THE LEFT (Diagram 1)

First, unplug the power cord from the surge protector. Using the hex key provided, turn the left rear roller adjustment bolt  $\frac{1}{4}$  turn in the clockwise direction. Plug the power cord back into the surge protector and run the treadmill at 2.5 mph. You should see the belt start to correct itself, moving back towards the center. Repeat the above procedure until the walking belt is centered. It may be necessary to set walking belt tension once you have completed this procedure if the belt feels like it is slipping while walking. Refer to below to the "Walking Belt Slipping" instructions.

## WALKING BELT HAS SHIFTING TO THE RIGHT (Diagram 2)

First, unplug the power cord from the surge protector. Using the hex key provided, turn the right rear roller adjustment bolt  $\frac{1}{4}$  turn in the clockwise direction. Plug the power cord back into the surge protector and run the treadmill at 2.5 mph. You should see the belt start to correct itself, moving back towards the center. Repeat the above procedure until the walking belt is centered. It may be necessary to set walking belt tension once you have completed this procedure if the belt feels like it is slipping while walking. Refer to below to the "Walking Belt Slipping" instructions.

## WALKING BELT IS SLIPPING DURING USE (Diagram 3)

First, unplug the power cord from the surge protector. Using the hex key provided, turn both left and right rear roller adjustment bolts the same distance, usually a  $\frac{1}{4}$  turn in the clockwise direction. Plug the power cord back into the surge protector and run the treadmill at 2.5 mph. You should now walk on the belt to determine if the belt is still slipping. Repeat the above procedure until the walking belt is not slipping. The tension should be just tight enough not to slip.

**WARNING:** Incorrect tension adjustment (too tight) may cause pre-mature roller failure. Do not over tighten.

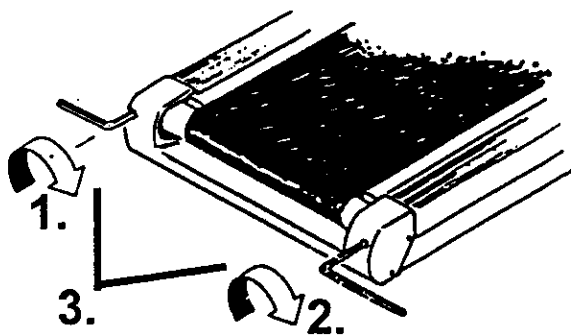

# Calibration Procedure

## Changing the readout from Miles per Hour to Kilometers per Hour

Your treadmill will operate in British Units (miles per hour) or International Units (kilometers per hour). All Keys treadmills are calibrated at the factory for British Units (miles per hour). To change the display to read in kilometers, follow the steps described here:

- 1) Power is turned OFF on the console.
- 2) Activate the calibration mode switch by inserting the eraser end of a pencil into the opening in the backside of the console (see diagram below).
- 3) Depressing the calibration mode switch will alternate the window display from "CL11" or "CL21". Make sure the "CL11" is showing in the window before proceeding.
- 4) The light beside the MPH should be blinking. To set display readout to KM/H, press the decrease (-) Speed button. To set display readout to Miles per hour, press the increase (+) Speed button.
- 5) To accept the setting, press the POWER button.

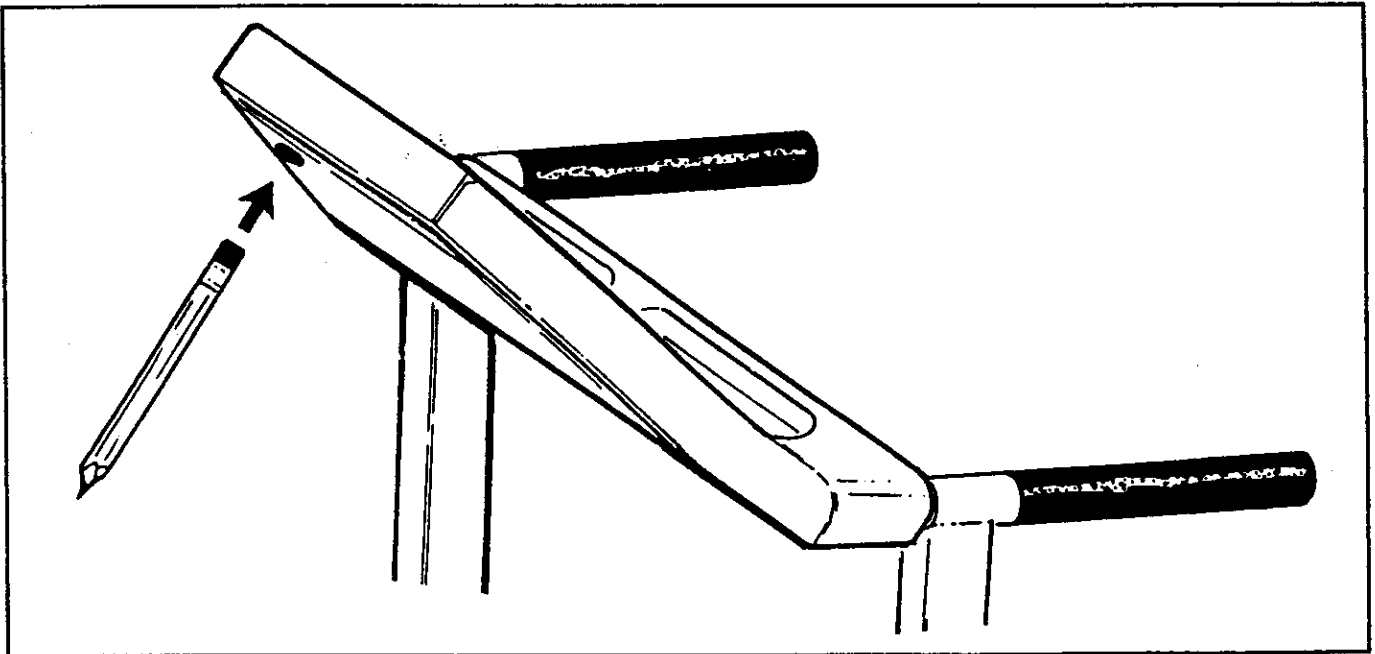

---

# Troubleshooting Guide

## Treadmill will not start.

- 1) Make sure the power cord is plugged into a surge protector, the surge protector is plugged into a properly grounded outlet, and the surge protector is turned on. (Refer to "How to Plug in the Power Cord")
- 2) Check the circuit breaker located on the front of the treadmill. If the switch protrudes, it has tripped. Wait five minutes and then press the switch back in.
- 3) Check the house electrical breaker box and the circuit breaker for the room the treadmill is located in. If it has tripped, reset or have an electrician replace the breaker in home.
- 4) Have an electrician check for inadequate voltage at the outlet.

## Treadmill loses power during use.

- 1) Check the circuit breaker located on the front of the treadmill. If the switch protrudes, it has tripped. Wait five minutes and then press the switch back in.
- 2) Check the house electrical breaker box and the circuit breaker for the room the treadmill is located in. If it has tripped, reset or have an electrician replace the breaker in home.
- 3) If treadmill still will not operate, please call our toll-free HELPLINE, (888) 340-0482.

## Treadmill walking belt slows during use.

- 1) Check to make sure the treadmill is securely plugged into an UL-listed surge protector, rated at 15 amps, with a 14-gauge cord of five feet or less and the surge protector is securely plugged into the outlet.
- 2) If treadmill still will not operate, please call our toll-free HELPLINE, (888) 340-0482.

## Treadmill walking belt slips or is not centered on rear roller.

- 1) Refer to "Belt Adjustment and Tension" section.
- 2) Need help? Call our toll-free HELPLINE, (888) 340-0482.

## Treadmill Error Messages.

Your treadmill is equipped with a software package that enables error messages to be displayed when there is a problem. **To avoid possible damage to the treadmill and the possibility of injury, do not operate the treadmill until the problem is corrected.**

Call our toll-free HELPLINE, (888) 340-0482 for recalibration procedures and self check information.

Error Codes include: E11, E22, E33, SI-1, SI-2

# Exercise Guide

## WARNING!

Before using this treadmill or starting any exercise program, consult your physician. This is especially important for persons over the age of 35 and/or persons with pre-existing health problems. Keys Fitness Products LP assumes no responsibility for personal injury or property damage sustained by or through the use of this product.

### WARM UP

Warming up prepares the body for exercise by increasing circulation, supplying more oxygen to the muscles and raising body temperature. Begin each workout with 5 to 10 minutes of stretching and light exercise to warm up. The drawings on this page show several forms of basic stretching you may perform before your workouts. Again, consult a physician before starting this or any other exercise program!

- 1) **Toe Touch Stretch** (Repeat 3 times). Stand bending your knees slightly and slowly bend forward from your hips. Allow your back and shoulders to relax as you reach down toward your toes as far as possible. Hold for 15 counts, then relax. This will stretch your hamstrings, back of knees, and back.
- 2) **Hamstring Stretch** (Repeat 3 times). Sit with one leg extended. Bring the sole of the opposite foot toward you and rest it against the inner thigh of your extended leg. Reach toward your toes as far as possible. Hold for 15 counts, then relax. Repeat with the other leg. This will stretch your hamstrings, lower back, and groin.
- 3) **Calf/Achilles Stretch** (Repeat 3 times). With one leg in front of the other, reach forward and place your hands against a wall. Keep your back leg straight and your back foot flat on the floor. Bend your front leg, lean forward and move your hips toward the wall. Hold for 15 counts, then relax. To cause further stretching of the achilles tendons, bend your back leg as well. Repeat with the other leg. This will stretch your calves, achilles tendons, and ankles.
- 4) **Quadriceps Stretch** (Repeat 3 times). With one hand against a wall for balance, reach back and grasp one foot with your other hand. Bring your heel as close to your buttocks as possible. Hold for 15 counts, then relax. Repeat with the other leg. This will stretch your quadriceps and hip muscles.
- 5) **Inner Thigh Stretch** (Repeat 3 times). Sit with the soles of your feet together and your knees outward. Pull your feet toward your groin area as far as possible. Hold for 15 counts, then relax. This will stretch your quadriceps and hip muscles.

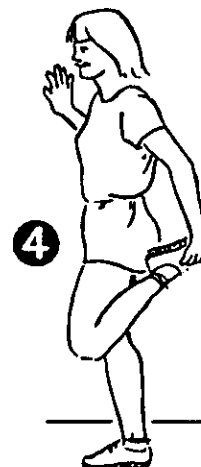
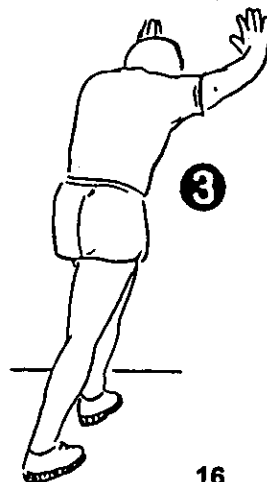
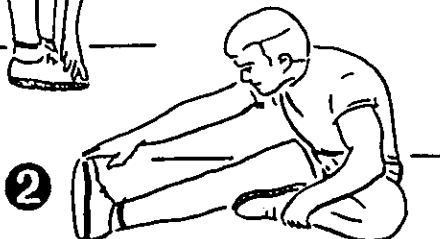
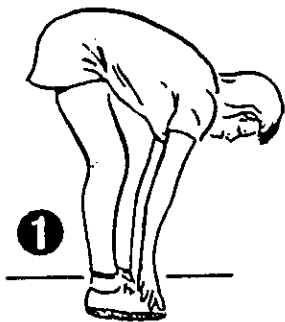



		Part #
1	Left Side Extrusion Rail	05-0007 Left
2	Right Side Extrusion Rail	05-0007 Right
3	Treadmill Belt	04-0001
4	Front Roller Assembly	09-0003
5	Rear Roller	09-0002
6	Treadmill Deck	03-0003
7	Rear End Cap	06-0008
8	Elevation Motor (acuator)	12-0006
9	Bottom Motor Pan	06-0057
10	Motor Fan	06-0037
11	Motor	12-0007
12	Motor Drive Belt	04-0004
13	Motor Hood Cover Top	06-0007
14	Console Upright	various
15	Upper electronics PC board	07-0012
16	Console & Membranes	various
17	Handlebars	various
18	Lower Electronics M/Control P/Supply	08-0015

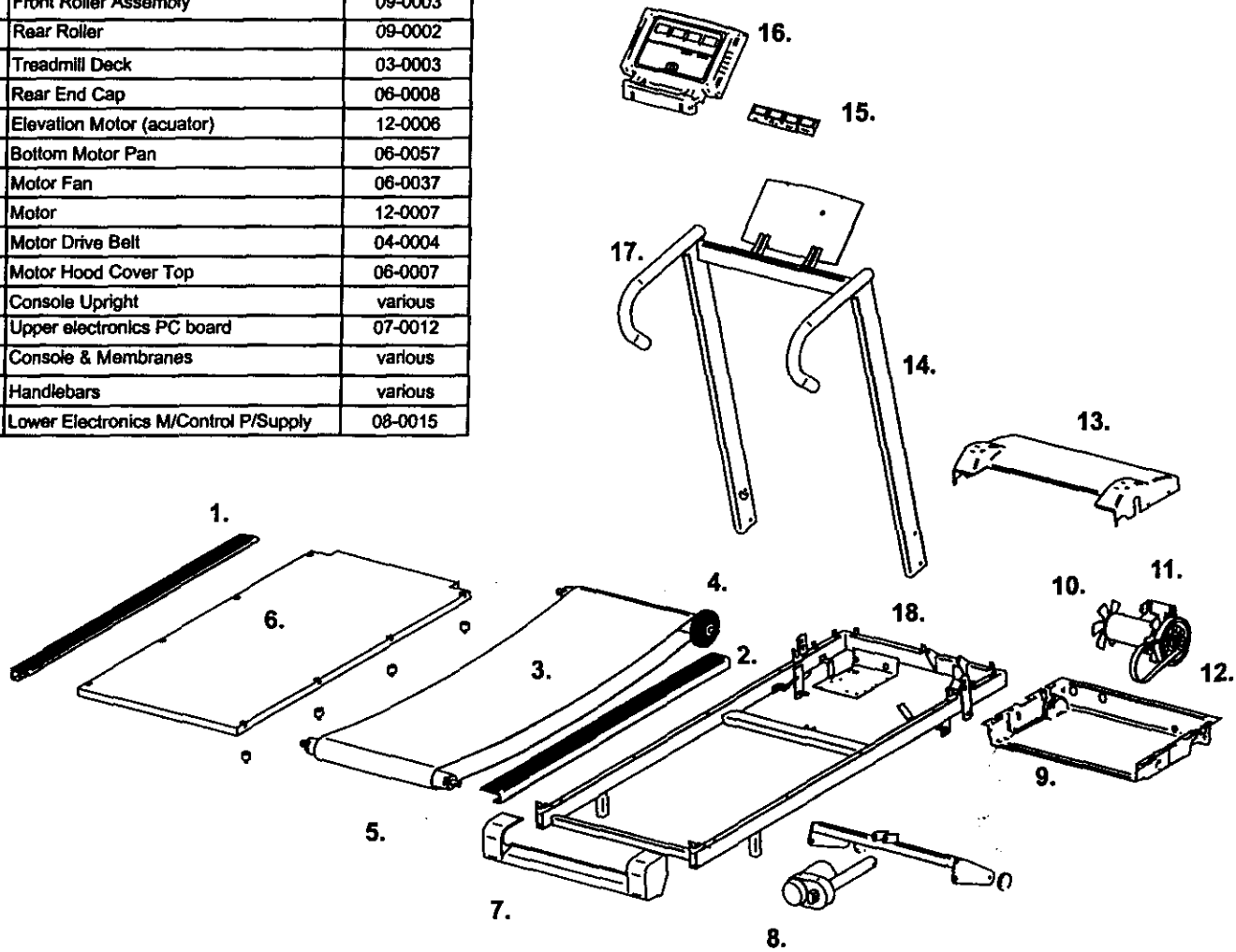





# PRO 750 Conventional TREADMILL

## QUESTIONS?

**CALL OUR TOLL FREE  
HELPLINE**

**USA: (888) 340-0482  
or  
(214) 340-8888**

**Canada: (800) 897-6025**

### CAUTION!

Please read the precautions and instructions in this manual before using this equipment. Please save this manual for future reference.

Dear Keys' Treadmill Customer!

Thank you for purchasing a Keys' treadmill! You have now invested in a superior quality product and a fitness lifestyle. We here at Keys Fitness Products have produced what we believe is the finest treadmill with exceptional value. A dedicated team of employees manufactures all Keys treadmills at our plant in Tyler, Texas.

Should you ever have a question concerning your treadmill, please feel free to give us a call at 1-888-340-0482. We will be glad to be at your service!

Sincerely yours in fitness!

Keys Fitness Products, LP

# OWNER'S MANUAL

**KEYS FITNESS PRODUCTS, LP  
11220 Petal Street  
Dallas, Texas 75238**

**MADE IN U.S.A.**