

# SEARS

## operator's manual

MODEL NO. 143.991004

SOLID STATE IGNITION

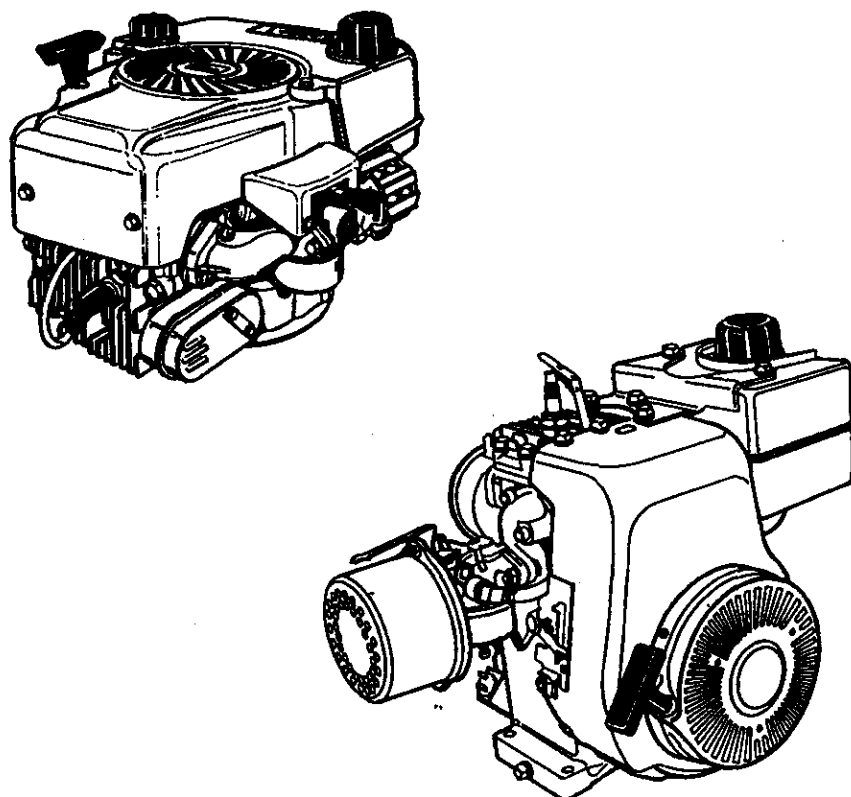

# ENGINE

- Operating
- Maintenance
- Repair Parts

### CAUTION:

Read RULES for  
Safe OPERATION  
and INSTRUCTIONS  
Carefully



California Proposition 65 **WARNING:** The engine exhaust from this product contains chemicals known to the State of California to cause cancer, birth defects or other reproductive harm.

Sold by SEARS, ROEBUCK AND CO., CHICAGO, IL 60684 U.S.A.  
and SEARS CANADA, INC., TORONTO, ONTARIO, CANADA

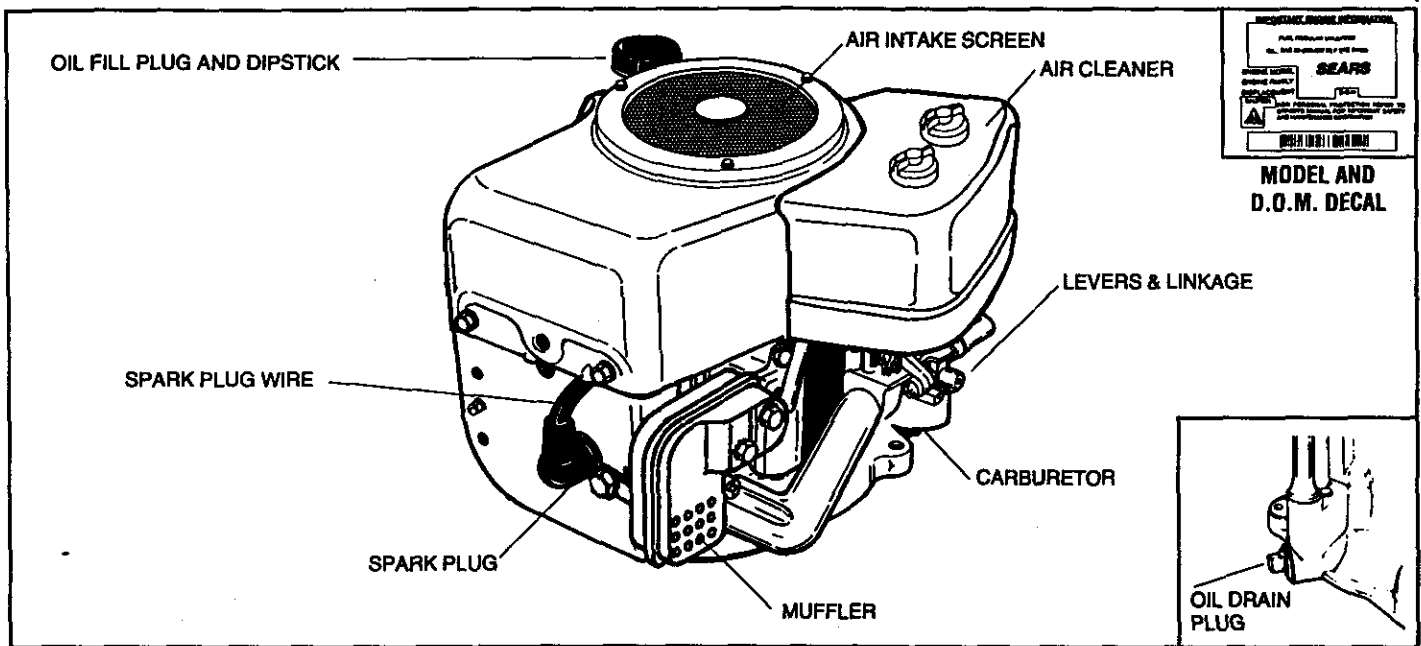

Figure 1

**THIS SYMBOL POINTS OUT IMPORTANT SAFETY INSTRUCTIONS WHICH IF NOT FOLLOWED COULD ENDANGER THE PERSONAL SAFETY AND/OR PROPERTY OF YOURSELF AND OTHERS. READ AND FOLLOW ALL INSTRUCTIONS IN THIS MANUAL AND ANY PROVIDED WITH THE EQUIPMENT ON WHICH THIS ENGINE IS USED BEFORE ATTEMPTING TO OPERATE YOUR CRAFTSMAN ENGINE.**

THESE SYMBOLS MAY APPEAR ON THE ENGINE:

FAST	SLOW	STOP	OFF	CHOKE	FULL

**ENGINES WHICH ARE CERTIFIED TO COMPLY WITH CALIFORNIA AND U.S. EPA EMISSION REGULATIONS FOR ULGE ENGINES:** Are certified to operate on regular unleaded gasoline. Include the following emission control system(s): EM, TWC (if so equipped); Do not include any user adjustable features - therefore no other adjustments are needed

## OIL & FUEL RECOMMENDATIONS

TO OPERATE ENGINE, YOU WILL NEED THE FOLLOWING:

### ① A CLEAN, HIGH QUALITY, DETERGENT OIL.

Be sure original container is marked:

A.P.I. service "SF"- "SJ".

**FOR SUMMER (ABOVE 32°F; 0°C) USE SAE 30 OIL.**

Using multigrade oil will increase oil consumption.

**FOR WINTER (BELOW 32°F; 0°C) USE SAE 5W30 OIL.**

(SAE 10W is an acceptable substitute.)

**DO NOT USE SAE 10W40 OIL.**

**OIL SUMP CAPACITY:** 32 ounces (2 pints).

.94 liter

### ② A FRESH, CLEAN, UNLEADED REGULAR, UNLEADED PREMIUM, OR REFORMULATED AUTOMOTIVE GASOLINE ONLY. DO NOT USE LEADED GASOLINE.

**NOTE:** DO NOT USE GASOLINE CONTAINING METHANOL (WOOD ALCOHOL). Gasoline containing up to 10% ethanol or grain alcohol ("Gasohol"), or up to 15% MTBE (Methyl Tertiary Butyl Ether), may be used but requires special care when engine is unused for extended periods.

See "STORAGE" instruction on Page 4.

**NOTE:** Use clean oil and fuel and store in approved, clean covered containers. Use clean fill funnels.

Never use "stale" gasoline left over from last season or stored for long periods.

## IMPORTANT

**KEEP THIS MANUAL HANDY AT ALL TIMES FOR FUTURE REFERENCE. READ IT CAREFULLY AND FAMILIARIZE YOURSELF WITH THE OPERATING, MAINTENANCE AND SAFETY INSTRUCTIONS. THIS MANUAL ALSO CONTAINS A COMPLETE PARTS LISTING.**

## BEFORE STARTING

① **READ ALL INSTRUCTIONS PROVIDED WITH THE EQUIPMENT ON WHICH THIS ENGINE IS USED.**

### ② CHECK OIL LEVEL:

**CAUTION: NEVER RUN ENGINE UNLESS OIL LEVEL IS BETWEEN "FULL" AND "ADD" MARKS ON DIPSTICK.**

**CHECK OIL LEVEL OFTEN DURING ENGINE BREAK-IN. NEVER RUN ENGINE UNLESS OIL FILL PLUG IS TIGHTENED SECURELY INTO OIL FILL HOLE.**

- POSITION EQUIPMENT SO ENGINE IS LEVEL.
- Clean area around oil fill plug (see Figure 1).
- Remove oil fill plug and dipstick.
- Wipe dipstick clean, insert it into oil fill hole and tighten securely.
- Remove oil fill plug and check oil level. If level is not up to "FULL" mark on dipstick, add recommended oil, until it is. **POUR SLOWLY.** Wipe dipstick clean each time oil level is checked.  
**DO NOT FILL ABOVE "FULL" MARK ON DIPSTICK.**
- Replace oil fill plug and tighten securely.

## BEFORE STARTING (Continued)

### TO ENSURE ADEQUATE OIL SUPPLY:

**G. DISCONNECT SPARK PLUG WIRE FROM SPARK PLUG AND KEEP IT AWAY FROM SPARK PLUG.**

H. Crank engine a few times with starter.

**NOTE - DO NOT USE MOWER CUTTING BLADE OR ANY OTHER ATTACHMENT ON POWER TAKE-OFF END OF CRANKSHAFT TO CRANK ENGINE.**

I. Re-check oil level per instructions C, D, E and F.

J. Connect spark plug wire to spark plug.

See "MAINTENANCE" section for any future oil level and oil change instructions (see Page 2).

**③ FILL FUEL TANK** with gasoline as specified in the preceding "OIL & FUEL RECOMMENDATIONS," item 2.

### NEVER MIX OIL WITH GASOLINE

Never use "stale" gasoline left over from last season or stored for long periods.

**NEVER FILL FUEL TANK INDOORS. NEVER FILL FUEL TANK WHEN ENGINE IS RUNNING OR HOT. DO NOT SMOKE WHEN FILLING FUEL TANK.**

**NEVER FILL FUEL TANK COMPLETELY. FILL TANK TO 1/2" BELOW BOTTOM OF FILLER NECK TO PROVIDE SPACE FOR FUEL EXPANSION. WIPE ANY FUEL SPILLAGE FROM ENGINE AND EQUIPMENT BEFORE STARTING ENGINE.**

**ANY LIQUEFIED PETROLEUM (LPG) OR NATURAL GAS FUEL SYSTEM MUST BE LEAKPROOF AND MEET ALL APPLICABLE CODES AND REGULATIONS.**

**④ CHECK THE FOLLOWING:**

**A. BE SURE EQUIPMENT IS IN NEUTRAL GEAR WITH CLUTCHES, BELTS, CHAINS AND SAFETY SWITCHES DISENGAGED. (FOLLOW EQUIPMENT MANUFACTURER'S INSTRUCTIONS). THIS SHOULD PLACE ANY SAFETY SWITCHES IN SAFE STARTING POSITION.**

B. Be sure spark plug wire is attached to spark plug (see Figure 1).

C. Be sure any ignition switch on engine or equipment is in ON, RUN or START position.

## STARTING

**NEVER RUN ENGINE INDOORS OR IN ENCLOSED, POORLY VENTILATED AREAS. ENGINE EXHAUST CONTAINS CARBON MONOXIDE, AN ODORLESS AND DEADLY GAS (CARBON MONOXIDE IS ALSO PRESENT IN ENGINE EXHAUST FROM LIQUID PETROLEUM (LPG) AND NATURAL GAS FUEL SYSTEMS).**

**KEEP HANDS, FEET, HAIR AND LOOSE CLOTHING AWAY FROM ANY MOVING PARTS ON ENGINE AND EQUIPMENT.**

**BE SURE AIR INTAKE SCREEN (see Fig. 1) IS SECURELY IN PLACE TO AVOID CONTACT WITH MOVING PARTS.**

**WARNING TEMPERATURE OF MUFFLER AND NEARBY AREAS MAY EXCEED 150°F (65°C). AVOID THESE AREAS.**

NOTE: If engine is remotely controlled, see equipment manufacturer's instructions for remote control positions which correspond to engine control positions in Figure 2.

### ELECTRIC STARTER 12 VOLT D.C.:

A. Move engine control lever (see Figure 2) or equipment control to CHOKE or START.

NOTE: IF RESTARTING A WARM ENGINE, AFTER A SHORT SHUTDOWN, MOVE CONTROL TO "FAST" INSTEAD OF "CHOKE."

## STARTING (Continued)

B. Press starter button or turn ignition switch key per equipment manufacturer's instructions to crank engine until it fires.

C. When engine starts move control to FAST and then to RUN RANGE.

D. If engine falters, move control to CHOKE, then to FAST and then to RUN RANGE.

NOTE: If engine fires, but does not continue to run, move control to FAST and crank engine until it starts.

E. If engine still does not start, move control to CHOKE and repeat instructions B and C again.

## STOPPING

① Move equipment control or any ignition stop switch on engine to STOP or OFF (see equipment manufacturer's instructions).

② AFTER ENGINE IS STOPPED:

**A. DISCONNECT SPARK PLUG WIRE FROM SPARK PLUG AND KEEP IT AWAY FROM SPARK PLUG.**

**B. TURN IGNITION SWITCH KEY (IF SO EQUIPPED) TO "OFF" POSITION AND REMOVE KEY FROM SWITCH. THIS WILL REDUCE THE POSSIBILITY OF UNAUTHORIZED STARTING OF ENGINE WHILE EQUIPMENT IS NOT IN USE.**

**NEVER STORE ENGINE WITH FUEL IN TANK IN DOORS OR IN ENCLOSED, POORLY VENTILATED AREAS, WHERE FUEL FUMES MAY REACH AN OPEN FLAME, SPARK OR PILOT LIGHT AS ON A FURNACE, WATER HEATER, CLOTHES DRYER OR OTHER GAS APPLIANCE.**

## MAINTENANCE

**WARNING TEMPERATURE OF MUFFLER AND NEARBY AREAS MAY EXCEED 150°F (65°C). AVOID THESE AREAS.**

① CHECK OIL LEVEL:

Check oil level every five (5) operating hours or each time engine is used. See "2 CHECK OIL LEVEL" in "BEFORE STARTING" on Page 1.

② CHANGE OIL:

Change oil after first two (2) operating hours and every 25 operating hours thereafter, more often if operated in extremely dusty or dirty conditions.

Change oil while engine is still warm from recent running.

**A. DISCONNECT SPARK PLUG WIRE FROM SPARK PLUG AND KEEP IT AWAY FROM SPARK PLUG.**

B. Position equipment so engine oil drain plug is lowest point on engine.

C. Remove oil drain plug and oil fill plug to drain oil.

D. Replace oil drain plug and tighten securely.

E. Fill oil sump with recommended oil. See "OIL & FUEL RECOMMENDATIONS" and "CHECK OIL LEVEL" on Page 1.

F. Replace oil fill plug and tighten securely.

G. Connect spark plug wire to spark plug.

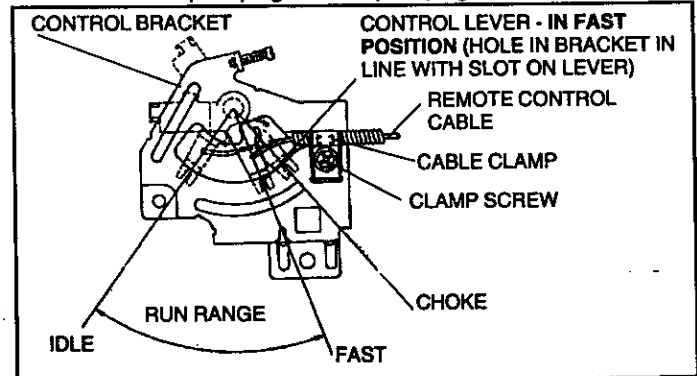

## MAINTENANCE (Continued)

### ③ AIR CLEANER:

**IMPORTANT: NEVER RUN ENGINE WITHOUT COMPLETE AIR CLEANER INSTALLED ON ENGINE.**

#### A. TO SERVICE FILTER(S) (see Figure 3):

##### 1. FOAM FILTER:

Clean and re-oil every three (3) months or every 25 operating hours. Clean and re-oil daily if used in extremely dusty conditions.

- Wash in water and detergent solution and squeeze (don't twist) until all dirt is removed.
- Rinse thoroughly in clear water.
- Wrap in a clean cloth and squeeze (don't twist) until completely dry.
- Saturate with engine oil and squeeze (don't twist) to distribute oil and remove excess oil.

##### 2. PAPER OR FOAM/SCREEN FILTERS:

###### - DO NOT ATTEMPT TO CLEAN OR OIL FILTER.

Replace once a year or every 100 operating hours, more often if used in extremely dusty conditions.

Replacement filters are available at any nearby Sears Roebuck and Co. (or Sears Canada, Inc.) Service Center.

#### B. TO REMOVE AND INSTALL FILTER(S):

- Remove wing nuts and cover.
- Slide FILTER A off FILTER B.
- Inspect filter(s) for discoloration or dirt accumulation. If either is present, service per preceding "TO SERVICE FILTER(S)" instructions.
- Remove nuts and FILTER B. Discard FILTER B and nuts (if service is necessary).
- Clean inside of cover and body thoroughly.
- Install new FILTER B and new nuts. Tighten nuts finger tight and then turn one (1) more complete turn.
- Slide foam filter over paper filter.
- Install cover and wing nuts. Tighten wing nuts.

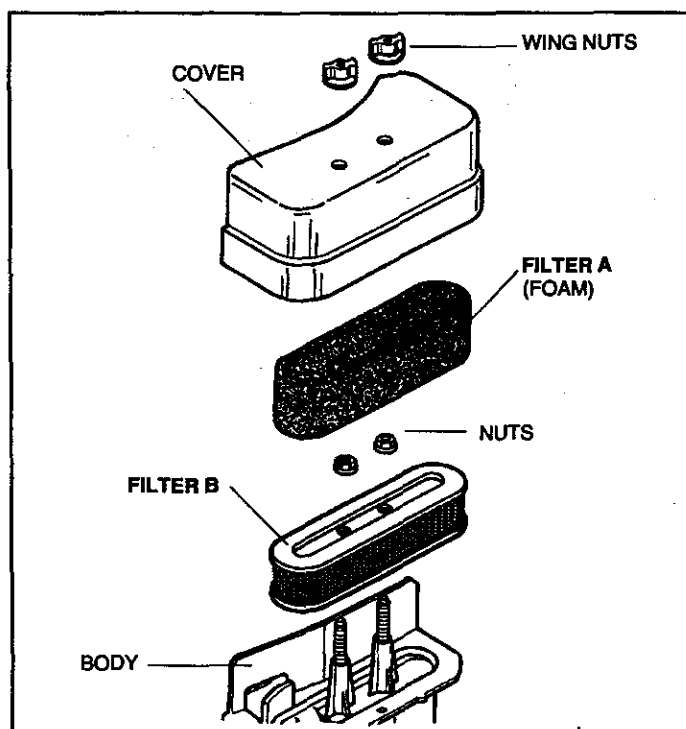

Figure 3

## MAINTENANCE (Continued)

### ④ SPARK PLUG (see Figure 4):

This spark ignition system meets all requirements of the Canadian Interference-Causing Equipment Regulations. This engine complies with all current Australian and New Zealand limitations regarding electromagnetic interference. Check spark plug yearly or every 100 operating hours.

- Clean area around spark plug.
- Remove and inspect spark plug.
- Replace spark plug if electrodes are pitted, burned or porcelain is cracked. For replacement use Champion RJ-19LM or equivalent.  
**NOTE: A resistor spark plug must be used for replacement.**
- Check electrode gap with wire feeler gauge and set gap at .030 if necessary.
- Install spark plug, tighten securely.

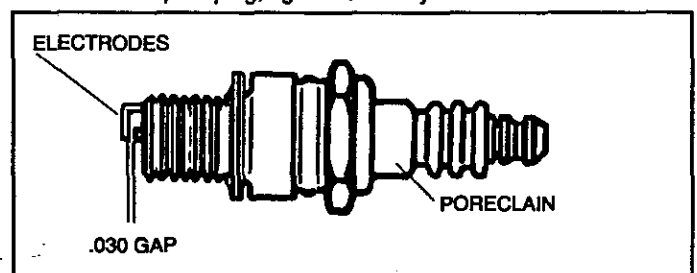

Figure 4

### ⑤ ALTERNATOR AND BATTERY (if so equipped):

#### A. ALTERNATOR:

For electrical problems such as inoperative starter or discharged battery, see your nearby Sears Roebuck and Co. (or Sears Canada, Inc.) Service Center for fuse replacement (if so equipped), maintenance and repairs.

#### B. BATTERY:

- When servicing battery, always connect cables to battery exactly as they were before removal (ground cable to battery negative [- or neg.] post). If incorrectly connected, alternator won't charge battery. If this happens, see your Sears Roebuck and Co. (or Sears Canada, Inc.) Service Center.
- Never expose engine ignition system to battery power. If battery cable or any live wire contacts ignition system ground wire, engine ignition system may be damaged.
- If external battery charger is used, disconnect positive (+ or pos.) cable from battery to prevent possible damage.
- See battery manufacturer's instructions for service and storage.

### ⑥ COOLING SYSTEM:

**IMPORTANT:** Frequently remove any grass clippings, dirt and debris from cooling fins, air intake screen and levers and linkage (see Figures 1 and 5). This will help ensure adequate cooling and correct engine speed.

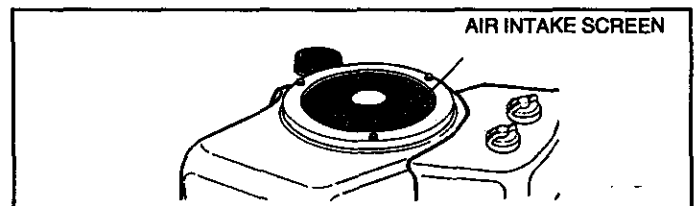

Figure 5

⑦ **CHECK ENGINE AND EQUIPMENT OFTEN FOR LOOSE NUTS, BOLTS AND ATTACHMENTS AND KEEP THESE ITEMS TIGHTENED.**

## ADJUSTMENTS

DO NOT MAKE UNNECESSARY ADJUSTMENTS. FACTORY SETTINGS ARE SATISFACTORY FOR MOST APPLICATIONS AND CONDITIONS. IF ADJUSTMENTS ARE NEEDED, PROCEED AS FOLLOWS:

### ① CARBURETOR (see Figure 6):

If you think your carburetor needs adjusting, see your nearest SEARS, ROEBUCK AND CO. (OR SEARS CANADA, INC.) SERVICE CENTER. Engine performance should not be affected at altitudes up to 7,000 feet. For operation at higher elevations, contact your nearest SEARS, ROEBUCK AND CO. (OR SEARS CANADA, INC.) SERVICE CENTER.

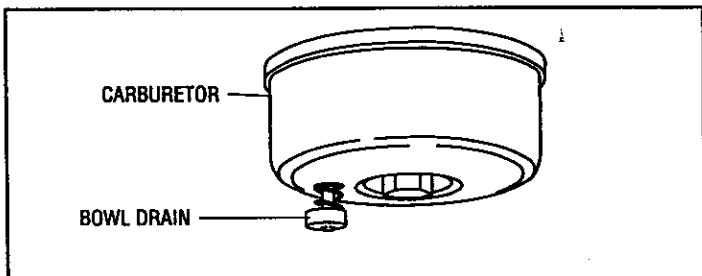

Figure 6

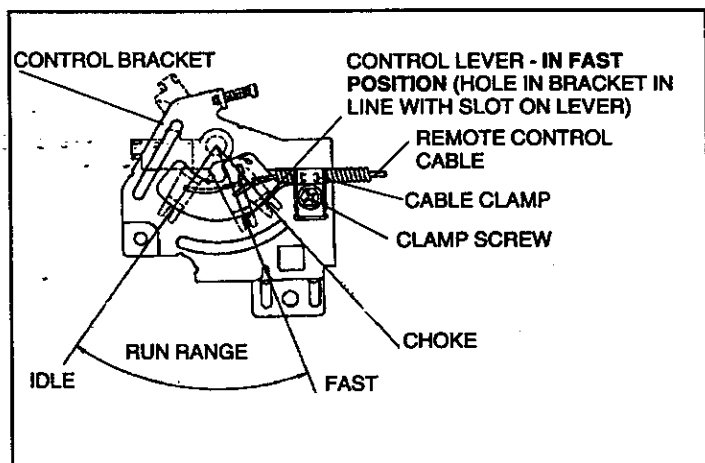

Figure 7

### ② REMOTE CONTROL (see Figure 7):

For satisfactory engine performance, engine and equipment controls must be adjusted properly. To check engine control adjustments, proceed as follows:

- A. Set equipment control at **FAST** or **HIGH SPEED** and keep in this position.
- B. Loosen clamp screw so remote control cable can be moved in cable clamp (do not remove cable clamp from control bracket or disconnect remote control cable from engine control lever).
- C. Move engine control lever into **FAST** and hold in this position.
- D. Tighten clamp screw securely so cable clamp will hold cable casing in place when equipment control is used. The engine should now run at the desired speed when equipment control is set at **FAST**, and should choke engine when in **CHOKE**.

## ADJUSTMENTS (Continued)

If additional control adjustments are necessary, contact your nearby Sears Roebuck and Co. (or Sears Canada, Inc.) Service Center.

### ③ ENGINE SPEED:

**NEVER TAMPER WITH ENGINE GOVERNOR WHICH IS FACTORY SET FOR PROPER ENGINE SPEED. OVERSPEEDING ENGINE ABOVE FACTORY HIGH SPEED SETTING CAN BE DANGEROUS. CHANGING OF ENGINE-GOVERNED SPEED WILL VOID ENGINE WARRANTY.**

## STORAGE

**NEVER STORE ENGINE WITH FUEL IN TANK INDOORS OR IN ENCLOSED, POORLY VENTILATED AREAS, WHERE FUEL FUMES MAY REACH AN OPEN FLAME, SPARK OR PILOT LIGHT AS ON A FURNACE, WATER HEATER, CLOTHES DRYER OR OTHER GAS APPLIANCE.**

IF ENGINE IS TO BE UNUSED FOR 30 DAYS OR MORE, PREPARE AS FOLLOWS:

### ① DRAIN FUEL SYSTEM:

Remove all gasoline from carburetor and fuel tank to prevent gum deposits from forming on these parts and causing possible malfunction of engine.

**DRAIN FUEL INTO APPROVED CONTAINER OUTDOORS, AWAY FROM OPEN FLAME. BE SURE ENGINE IS COOL. DO NOT SMOKE.**

Run engine until fuel tank is empty and engine stops due to lack of fuel.

**NOTE:** Fuel stabilizer (such as STA-BIL) is an acceptable alternative in minimizing the formation of gum deposits during storage. Add stabilizer to gasoline in fuel tank or storage container. Always follow mix ratio found on stabilizer container. Run engine at least 10 minutes after adding stabilizer to allow it to reach carburetor.

### ② CHANGE OIL:

Change oil if it has not been changed in the last three (3) months. See "CHANGE OIL" instructions in "MAINTENANCE" section.

### ③ OIL CYLINDER BORE:

- A. Remove spark plug. Squirt one (1) oz. (30 ml) of clean engine oil into spark plug hole.
- B. Cover spark plug hole with a rag.
- C. Crank engine over, slowly, several times.

**AVOID SPRAY FROM SPARK PLUG HOLE WHEN CRANKING ENGINE OVER SLOWLY.**

- D. Install spark plug. Do not connect spark plug wire.

### ④ CLEAN ENGINE:

Remove any clippings, dirt, or chaff from exterior of engine.

## GENERAL

Just as your automobile needs professional mechanical maintenance from time to time, so does your Craftsman engine. Replacement of the spark plug and air cleaner is made necessary by **NORMAL** use. Professional Air-Cooled Engine Service is as close as your nearest Sears Roebuck and Co. (or Sears Canada, Inc.) Service Center.

A yearly check-up or tune-up by Sears is a good idea to avoid breakdowns or delay . . . do it at the end of the season, then you're ready for the next. We even prepare it for storage for you.

# TROUBLESHOOTING

**THE FOLLOWING MAY HELP AVOID A DELAY IN YOUR WORK OR  
SAVE THE EXPENSE OF A SERVICE CALL.**

<b>ENGINE FAILS TO START OR STARTS WITH DIFFICULTY</b>	
<b>CAUSE</b>	<b>REMEDY</b>
Controls not in start position.	Move <b>ENGINE CONTROL</b> or equipment control to "HI" or <b>START</b> position. See " <b>STARTING</b> " instructions in this manual.
Spark plug wire disconnected from spark plug.	Connect <b>SPARK PLUG WIRE</b> to <b>SPARK PLUG</b> .
Spark plug fouled.	Remove <b>SPARK PLUG</b> and clean it. See " <b>SPARK PLUG</b> " instructions in " <b>MAINTENANCE</b> " section in this manual.
Spark plug porcelain cracked.	Install new spark plug.
Insufficient fuel.	Fill <b>FUEL TANK</b> per " <b>BEFORE STARTING</b> " instructions.
Water or dirt in fuel.	Drain <b>FUEL TANK</b> and re-fill with clean, fresh gasoline. See " <b>BEFORE STARTING</b> " instructions in this manual.
Improper carburetor adjustment	Adjust carburetor (if applicable). See " <b>ADJUSTMENTS</b> " section in this manual.
<b>ENGINE LACKS POWER</b>	
<b>CAUSE</b>	<b>REMEDY</b>
Dirty air cleaner.	Replace or clean air cleaner per " <b>AIR CLEANER</b> " instructions in " <b>MAINTENANCE</b> " section in this manual.
Improper carburetor adjustment.	Adjust carburetor (if applicable). See " <b>ADJUSTMENTS</b> " section in this manual.
Lack of lubrication.	Fill oil sump to proper level. See " <b>BEFORE STARTING</b> " instructions section in this manual.
<b>ENGINE MISSES UNDER LOAD</b>	
<b>CAUSE</b>	<b>REMEDY</b>
Spark plug fouled.	Remove <b>SPARK PLUG</b> and clean it. See " <b>SPARK PLUG</b> " instructions in " <b>MAINTENANCE</b> " section in this manual.
Spark plug porcelain cracked.	Install new <b>SPARK PLUG</b> .
Improper spark plug gap.	Regap <b>SPARK PLUG</b> electrodes. See " <b>SPARK PLUG</b> " instructions in " <b>MAINTENANCE</b> " section in this manual.
Improper carburetor adjustment	Adjust carburetor (if applicable). See " <b>ADJUSTMENTS</b> " section in this manual.

## SEARS, ROEBUCK AND CO.

# Federal and California Emission Control Systems Limited Warranty Utility and Lawn and Garden Engines

### CALIFORNIA & US EPA EMISSION CONTROL WARRANTY STATEMENT

The U. S. Environmental Protection Agency ("EPA"), the California Air Resources Board ("CARB") and Sears, Roebuck and Co. are pleased to explain the Federal and California Emission Control Systems Warranty on your new utility or lawn and garden equipment engine. In California, new 1995 and later utility and lawn and garden equipment engines must be designed, built and equipped to meet the State's stringent anti-smog standards. In other states, new 1997 and later model year engines must be designed, built and equipped, at the time of sale, to meet the U.S. EPA regulations for small non-road engines. Sears, Roebuck and Co. will warrant the emission control system on your utility or lawn and garden equipment engine for the periods of time listed below, provided there has been no abuse, neglect, unapproved modification, or improper maintenance of your utility or lawn and garden equipment engine.

Your emission control system may include parts such as the carburetor, ignition system and exhaust system. Also included may be the compression release system and other emission-related assemblies.

Where a warrantable condition exists, Sears, Roebuck and Co. will repair your utility or lawn and garden equipment engine at no cost to you for diagnosis, parts and labor.

### MANUFACTURER'S EMISSION CONTROL SYSTEM WARRANTY COVERAGE

Emission control systems on 1995 and later model year California utility and lawn and garden equipment engines are warranted for two years as hereinafter noted. In other states, 1997 and later model year engines are also warranted for two years. If, during such warranty period, any emission-related part on your engine is defective in materials or workmanship, the part will be repaired or replaced by Sears, Roebuck and Co.

### OWNER'S WARRANTY RESPONSIBILITIES

As the utility or lawn and garden equipment engine owner, you are responsible for the performance of the required maintenance listed in your Owner's Manual, but Sears, Roebuck and Co. will not deny warranty solely due to the lack of receipts or for your failure to provide written evidence of the performance of all scheduled maintenance.

As the utility or lawn and garden equipment engine owner, you should, however, be aware that Sears, Roebuck and Co. may deny you warranty coverage if your utility or lawn and garden equipment or a part thereof has failed due to abuse, neglect, improper maintenance or unapproved modifications.

You are responsible for presenting your utility or lawn and garden equipment engine to a Sears, Roebuck and Co. Authorized Service Outlet as soon as a problem exists. The warranty repairs should be completed in a reasonable amount of time, not to exceed 30 days.

Warranty service can be arranged by contacting either a Sears, Roebuck and Co. Authorized Service Outlet, or by contacting Sears, Roebuck and Co. at 1-800-473-7247.

### IMPORTANT NOTE

This warranty statement explains your rights and obligations under the Emission Control System Warranty ("ECS Warranty") which is provided to you by Sears, Roebuck and Co. pursuant to California law. See also the Sears, Roebuck and Co. Limited Warranties for Sears, Roebuck and Co. which is enclosed therewith on a separate sheet and also is provided to you by Sears, Roebuck and Co. The ECS Warranty applies only to the emission control system of your new engine. To the extent that there is any conflict in terms between the ECS Warranty and the Sears, Roebuck and Co. Warranty, the ECS Warranty shall apply except in any circumstances in which the Sears, Roebuck and Co. Warranty may provide a longer warranty period. Both the ECS Warranty and the Sears, Roebuck and Co. Warranty describe important rights and obligations with respect to your new engine.

Warranty service can only be performed by a Sears, Roebuck and Co. Authorized Service Outlet. At the time of requesting warranty service, evidence must be presented of the date of sale to the original purchaser. The purchaser shall pay any charges for making service calls and/or for transporting the products to and from the place where the inspection and/or warranty work is performed. The purchaser shall be responsible for any damage or loss incurred in connection with the transportation of any engine or any part(s) thereof submitted for inspection and/or warranty work.

If you have any questions regarding your warranty rights and responsibilities, you should contact Sears, Roebuck and Co. at 1-800-473-7247.

### EMISSION CONTROL SYSTEM WARRANTY

Emission Control System Warranty ("ECS Warranty") for 1995 and later model year California utility and lawn and garden equipment engines (for other states, 1997 and later model year engines):

**A. APPLICABILITY:** This warranty shall apply to 1995 and later model year California utility and lawn and garden equipment engines (for other states, 1997 and later model year engines). The ECS Warranty Period shall begin on the date the new engine or equipment is delivered to its original, end-use purchaser, and shall continue for 24 consecutive months thereafter.

**B. GENERAL EMISSIONS WARRANTY COVERAGE:** Sears, Roebuck and Co. warrants to the original, end-use purchaser of the new engine or equipment and to each subsequent purchaser that each of its utility and lawn and garden equipment engines is:

1. Designed, built and equipped so as to conform with all applicable regulations adopted by the Air Resources Board pursuant to its authority in Chapters 1 and 2, Part 5, Division 26 of the Health and Safety Code, and
2. Free from defects in materials and workmanship which, at any time during the ECS Warranty Period, will cause a warranted emissions-related part to fail to be identical in all material respects to the part as described in the engine manufacturer's application for certification.

**C. The ECS Warranty only pertains to emissions-related parts on your engine, as follows:**

1. Any warranted, emissions-related parts which are not scheduled for replacement as required maintenance in the Owner's Manual shall be warranted for the ECS Warranty Period. If any such part fails during the ECS Warranty Period, it shall be repaired or replaced by Sears, Roebuck and Co. according to Subsection 4 below. Any such part repaired or replaced under the ECS Warranty shall be warranted for any remainder of the ECS Warranty Period.
2. Any warranted, emissions-related part which is scheduled only for regular inspection as specified in the Owner's Manual shall be warranted for the ECS Warranty Period. A statement in such written instructions to the effect of "repair or replace as necessary", shall not reduce the ECS Warranty Period. Any such part repaired or replaced under the ECS Warranty shall be warranted for the remainder of the ECS Warranty Period.
3. Any warranted, emissions-related part which is scheduled for replacement as required maintenance in the Owner's Manual, shall be warranted for the period of time prior to the first scheduled replacement point for that part. If the part fails prior to the first scheduled replacement, the part shall be repaired or replaced by Sears, Roebuck and Co. according to Subsection 4 below. Any such emissions-related part repaired or replaced under the ECS Warranty, shall be warranted for the remainder of the ECS Warranty Period prior to the first scheduled replacement point for such emissions-related part.
4. Repair or replacement of any warranted, emissions-related part under this ECS Warranty shall be performed at no charge to the owner at a Sears, Roebuck and Co. Authorized Service Outlet.
5. The owner shall not be charged for diagnostic labor which leads to the determination that a part covered by the ECS Warranty is in fact defective, provided that such diagnostic work is performed at a Sears, Roebuck and Co. Authorized Service Outlet.
6. Sears, Roebuck and Co. shall be liable for damages to other original engine components or approved modifications proximately caused by a failure under warranty of an emission-related part covered by the ECS Warranty.
7. Throughout the ECS Warranty Period, Sears, Roebuck and Co. shall maintain a supply of warranted emission-related parts sufficient to meet the expected demand for such emission-related parts.
8. Any Sears, Roebuck and Co. authorized and approved emission-related replacement part may be used in the performance of any ECS Warranty maintenance or repair and will be provided without charge to the owner. Such use shall not reduce Sears, Roebuck and Co. ECS Warranty obligations.
9. Unapproved add-on or modified parts may not be used to modify or repair a Sears, Roebuck and Co. engine. Such use voids this ECS Warranty and shall be sufficient grounds for disallowing an ECS Warranty claim. Sears, Roebuck and Co. shall not be liable hereunder for failures of any warranted parts of a Sears, Roebuck and Co. engine caused by the use of such an unapproved add-on or modified part.

### EMISSION-RELATED PARTS INCLUDE THE FOLLOWING:

1. Carburetor Assembly and its Internal Components
  - a) Fuel filter
  - b) Carburetor gaskets
  - c) Intake pipe
2. Air Cleaner Assembly
  - a) Air filter element
3. Ignition System, including:
  - a) Spark plug
  - b) Ignition module
  - c) Flywheel assembly
4. Catalytic Muffler (if so equipped)
  - a) Muffler gasket (if so equipped)
  - b) Exhaust manifold (if so equipped)
5. Crankcase Breather Assembly and its Components
  - a) Breather connection tube

Sears, Roebuck and Co., Hoffman Estates, IL 60179 U.S.A.

7.22.97 EPA/CARB

# CRAFTSMAN 4-CYCLE ENGINE

MODEL: 143.991004

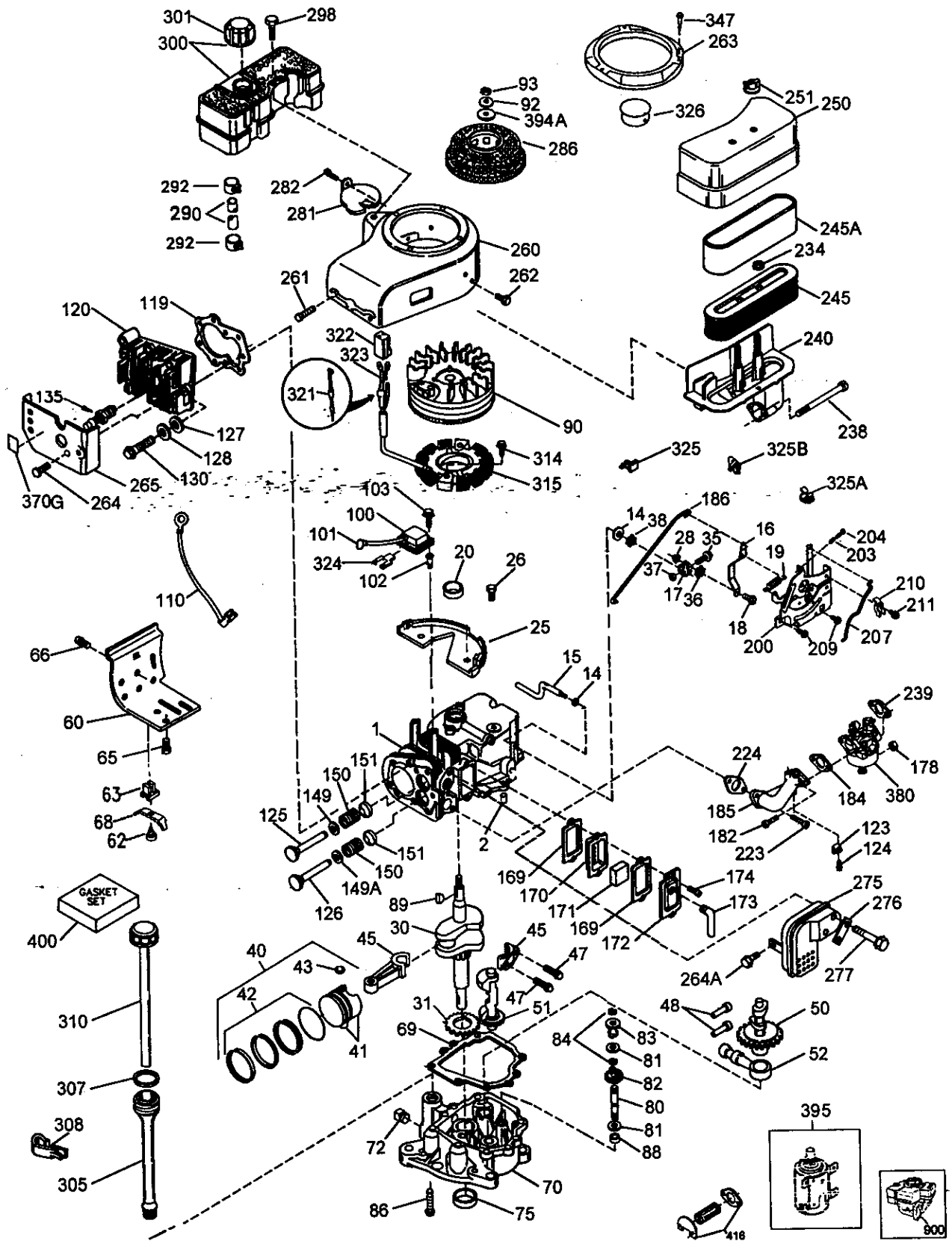



# CRAFTSMAN 4-CYCLE ENGINE

MODEL: 143.991004

Ref. No.	Part No.	Part Name	Ref. No.	Part No.	Part Name
1	35421	Cylinder (Incl. 2 & 20)	103	651007	Screw, Torx T-15, 10-24 x 15/16"
2	27652	Dowel Pin	110	35234	Ground Wire
14	28277	Washer	119	*36451	Cylinder Head Gasket
15	35082	Governor Rod	120	36449	Cylinder Head
16	36494	Governor Lever	123	33261	Intake Pipe Brace
17	29916	Governor Lever Clamp	124	651031	Screw, 1/4-20 x 9/16"
18	651028	Screw, Torx T-15, 8-32 x 3/8"	125	27878A	Exhaust Valve (Std.) (Incl. 151)
19	36495	Extension Spring	125	27880A	Exhaust Valve (1/32" OS) (Incl. 151)
20	35319	Oil Seal	126	34035	Intake Valve (Std.) (Incl. 151)
25	35424	Blower Housing Baffle	126	34036	Intake Valve (1/32" OS) (Incl. 151)
26	650561	Screw, 1/4-20 x 5/8"	127	650691	Washer
28	30322	Lock Nut, 8-32	128	650690	Belleville Washer
30	35429A	Crankshaft	130	650694A	Screw, 5/16-18 x 2"
31	35327	Counterbalance Gear	135	33636	Resistor Spark Plug (RJ17LM)
35	29826	Screw, 10-32 x 3/4"	149	27882	Valve Spring Cap
36	29918	Lock Washer	149A	35862	Valve Spring Cap
37	29216	Lock Nut, 10-32	150	27881	Valve Spring
38	29642	Retaining Ring	151	32581	Valve Spring Keeper
40	35776A	Piston, Pin & Ring Set (Std.)	169	*27896A	Valve Cover Gasket
40	35777A	Piston, Pin & Ring Set (.010" OS)	170	28423	Breather Body
40	35778A	Piston, Pin & Ring Set (.020" OS)	171	28424	Breather Element
41	35773A	Piston & Pin Ass'y. (Std.) (Incl. 43)	172	28425	Valve Cover
41	35774A	Piston & Pin Ass'y. (.010" OS) (Incl. 43)	173	35350	Breather Tube
41	35775A	Piston & Pin Ass'y. (.020" OS) (Incl. 43)	174	650128	Screw, 10-24 x 1/2"
42	35779	Ring Set (Std.)	178	29752	Nut & Lock Washer, 1/4-28
42	35780	Ring Set (.010" OS)	182	30088A	Screw, 1/4-28 x 1"
42	35781	Ring Set (.020" OS)	184	*33263	Carburetor To Intake Pipe Gasket
43	35772	Piston Pin Retaining Ring	185	34926	Intake Pipe
45	36895	Connecting Rod Ass'y. (Incl. 47)	186	33860	Governor Link
47	651033	Connecting Rod Bolt	200	35956	Control Bracket (Incl. 203 & 204)
48	34034	Valve Lifter	203	36482	Compression Spring
50	35381	Camshaft (MCR)	204	650777	Screw, 6-32 x 21/32"
51	35315A	Counterbalance Weight	207	35989	Choke Link
52	31356	Oil Pump Ass'y.	209	650902	Screw, 10-32 x 7/16"
60	33273A	Blower Housing Extension	210	27793	Conduit Clip
62	650760	Screw, 8-32 x 3/8"	211	28942	Screw, 10-32 x 3/8"
63	28545	Grommet	223	650378	Screw, Torx T-30, 5/16-18 x 1-1/8"
65	650128	Screw, 10-24 x 1/2"	224	*27915A	Intake Pipe Gasket
66	650990	Screw, Torx T-30, 1/4-20 X 15/32"	234	650825	Nut & Lock Washer, 1/4-20
68	33356	Ground Terminal	238	650834	Screw, 10-32 x 1-17/32"
69	*35317	Mounting Flange Gasket	239	*33629	Air Cleaner Gasket
70	35711A	Mounting Flange (Incl. 72, 75 & 80)	240	35538B	Air Cleaner Body (Incl. 239)
72	31927	Oil Drain Plug	245	35403	Air Cleaner Filter (Incl. 234)
75	35319	Oil Seal	245A	35404	Air Cleaner Filter
80	35783	Governor Shaft	250	35961	Air Cleaner Cover
81	30590A	Washer	251	650886	Wing Nut, 1/4-20
82	35378	Governor Gear Ass'y. (Incl. 81)	260	36266	Blower Housing
83	30588A	Governor Spool	261	650788	Screw, 5/16-18 x 3/4"
84	29193	Retaining Ring	262	29747B	Screw, Torx T-40, 5/16-24 x 21/32"
86	650833	Screw, 1/4-20 x 1-3/16"	263	35963	Trim Ring
88	31707A	Spacer (Incl. 81)	264	650990	Screw, 5/16-18 x 15/32"
89	32589	Flywheel Key	264A	650802	Screw, 1/4-20 x 5/8"
90	611093	Flywheel	265	33272B	Cylinder Head Cover
92	650880	Lock Washer			
93	650881	Flywheel Nut			
100	35135	Solid State Ignition			
101	610118	Spark Plug Cover			
102	651024	Solid State Mounting Stud			

\*Indicates Parts Included in Gasket Set, Ref. No. 400.

# CRAFTSMAN 4-CYCLE ENGINE

MODEL: 143.991004

Ref. No.	Part No.	Part Name	Ref. No.	Part No.	Part Name
275	40003	Muffler	325A	27275	Wire Clip
276	31588	Locking Plate	325B	34246	Wire Clip
277	650729	Screw, 5/16-18 x 3-3/16"	326	36210	Screen Plug
281	33013	Starter Bubble Cover	347	650949	Screw, 10-32 x 9/16"
282	650760	Screw, 8-32 x 3/8"	370G	35274	Oil Instruction Decal
286	35962	Cup & Screen	380	640091A	Carburetor (Incl. 184)
290	30705	Fuel Line	394A	650948	Washer
292	26460	Fuel Line Clamp	395	36680	Electric Starter Motor (12 Volt) (Optional)
298	28763	Screw, 10-32 x 35/64"	400	36452A	Gasket Set (Incl. Items Marked *)
300	33583B	Fuel Tank (Incl. 292, 298 & 301)	416	34479A	Spark Arrestor Screen Kit (Optional)
301	36246	Fuel Cap	900		Replacement Engine 752329, order from 71-999
305	35574	Oil Fill Tube	900		Replacement Short Block 752312A, order from 71-999
307	35499	"O" Ring			Operator's Manual
308	35437	Fill Tube Clip			
310	35576	Dipstick			
314	650873	Screw, 1/4-20 x 3/4"		181-1192-11	
315	611113	Alternator Coil (3 Amp) (Incl. 321 - 323)			
321	611161	Diode			*Indicates Parts Included in Gasket Set, Ref. No. 400.
322	610921	Connector Body			
323	610922	Terminal			RPM High 3250 to 3550
324	33177	Terminal			RPM Low 2000 to 2300
325	29443	Wire Clip			

## CARBURETOR NO. 640091A

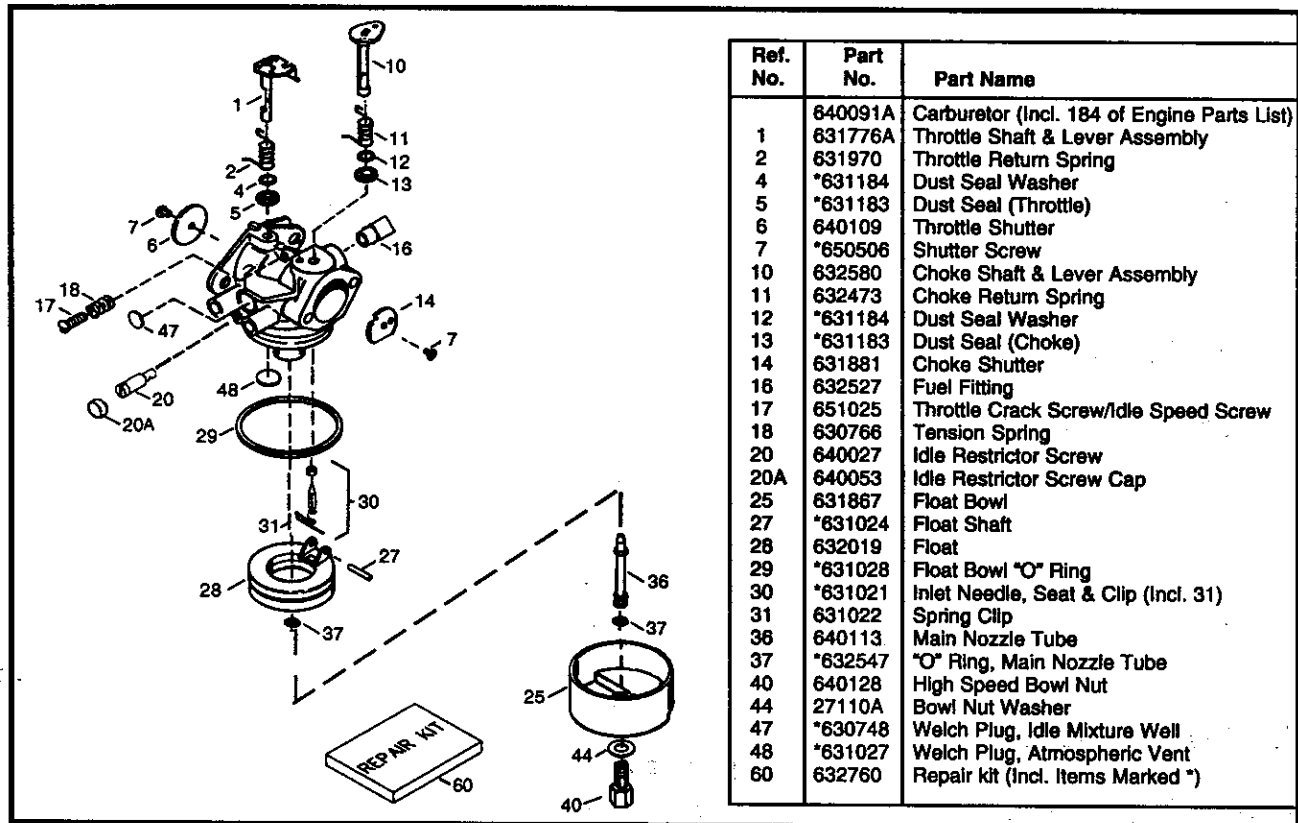

Ref. No.	Part No.	Part Name
1	640091A	Carburetor (Incl. 184 of Engine Parts List)
1	631776A	Throttle Shaft & Lever Assembly
2	631970	Throttle Return Spring
4	*631184	Dust Seal Washer
5	*631183	Dust Seal (Throttle)
6	640109	Throttle Shutter
7	*650506	Shutter Screw
10	632580	Choke Shaft & Lever Assembly
11	632473	Choke Return Spring
12	*631184	Dust Seal Washer
13	*631183	Dust Seal (Choke)
14	631881	Choke Shutter
16	632527	Fuel Fitting
17	651025	Throttle Crack Screw/Idle Speed Screw
18	630766	Tension Spring
20	640027	Idle Restrictor Screw
20A	640053	Idle Restrictor Screw Cap
25	631867	Float Bowl
27	*631024	Float Shaft
28	632019	Float
29	*631028	Float Bowl "O" Ring
30	*631021	Inlet Needle, Seat & Clip (Incl. 31)
31	631022	Spring Clip
36	640113	Main Nozzle Tube
37	*632547	"O" Ring, Main Nozzle Tube
40	640128	High Speed Bowl Nut
44	27110A	Bowl Nut Washer
47	*630748	Welch Plug, Idle Mixture Well
48	*631027	Welch Plug, Atmospheric Vent
60	632760	Repair Kit (Incl. Items Marked *)

## ELECTRIC STARTER MOTOR NO. 36680

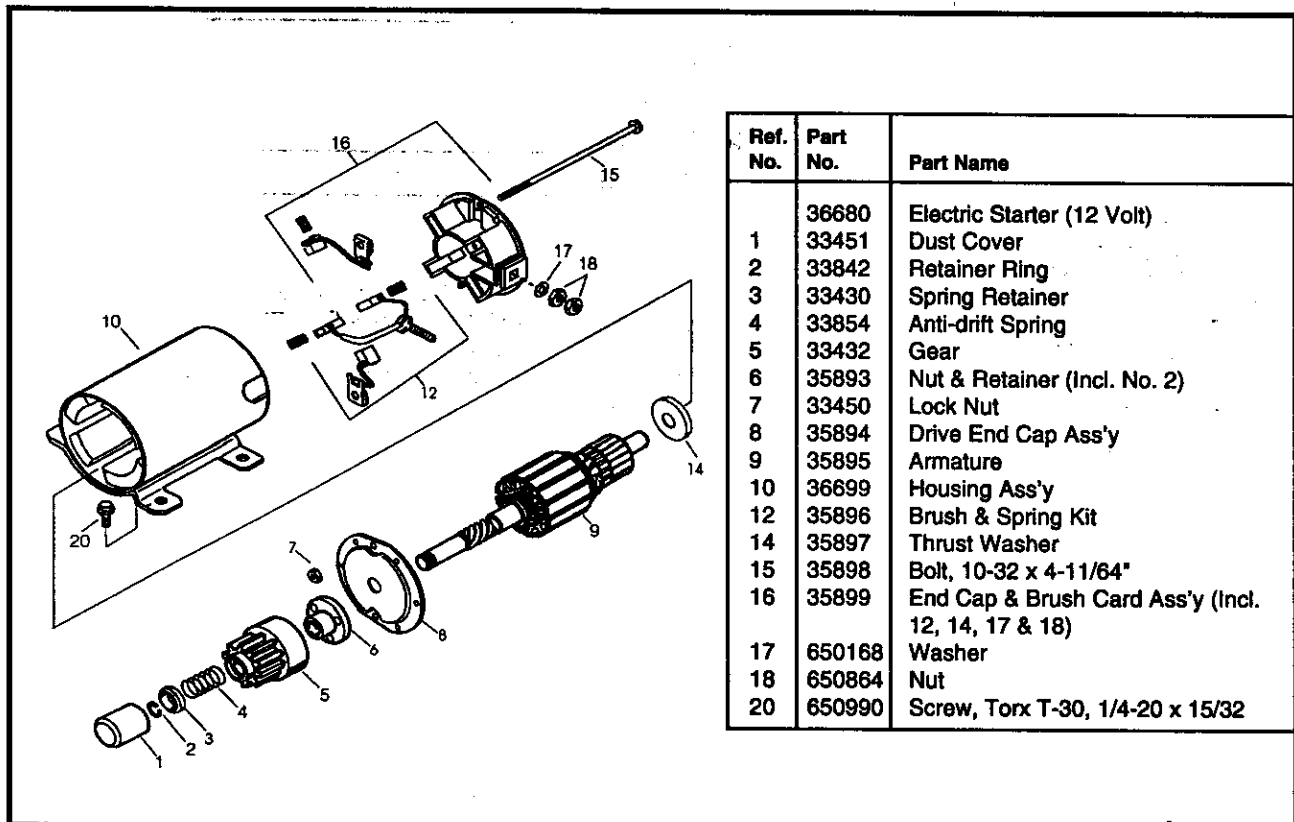

Ref. No.	Part No.	Part Name
	36680	Electric Starter (12 Volt)
1	33451	Dust Cover
2	33842	Retainer Ring
3	33430	Spring Retainer
4	33854	Anti-drift Spring
5	33432	Gear
6	35893	Nut & Retainer (Incl. No. 2)
7	33450	Lock Nut
8	35894	Drive End Cap Ass'y
9	35895	Armature
10	36699	Housing Ass'y
12	35896	Brush & Spring Kit
14	35897	Thrust Washer
15	35898	Bolt, 10-32 x 4-11/64"
16	35899	End Cap & Brush Card Ass'y (Incl. 12, 14, 17 & 18)
17	650168	Washer
18	650864	Nut
20	650990	Screw, Torx T-30, 1/4-20 x 15/32

# **SEARS**

## **operator's manual**

**MODEL NO. 143.991004**

**SOLID STATE IGNITION**

### **CAUTION:**

Read **RULES** for  
Safe **OPERATION**  
and **INSTRUCTIONS**  
Carefully

### ***How to ORDER Repair Parts***

The Model Number can be found on a decal on the blower housing (See Figure 1). Always mention the Model Number when requesting service or repair parts for your Craftsman Engine.

All parts listed herein may be ordered from any SEARS, ROEBUCK AND CO. or SEARS CANADA, INC. retail or catalog store. If the parts you need are not stocked locally, your order will be electronically transmitted to a Sears Repair Parts Distribution Center for expedited handling.

**WHEN ORDERING REPAIR PARTS, ALWAYS GIVE THE FOLLOWING INFORMATION AS SHOWN IN THIS LIST.**

1. The **PART NUMBER**
2. The **PART DESCRIPTION**
3. The **MODEL NUMBER**
4. The **NAME OF ITEM - ENGINE**

"Your Sears merchandise has added value when you consider that Sears has service units nationwide staffed with Sears trained technicians... professional technicians specifically trained on Sears products, having the parts, tools and equipment to insure that we meet our pledge to you ... we service what we sell."

**Sold by SEARS, ROEBUCK AND CO., CHICAGO, IL 60684 U.S.A.  
and SEARS CANADA, INC., TORONTO, ONTARIO, CANADA**