

Operator's Manual



Rear Engine Riding Mower with Electric Start

Model No.

107.280340 (12.5HP Briggs & Stratton Engine with 28" Mower Deck)

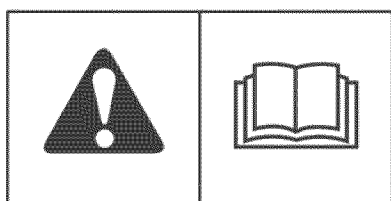

For answers to your questions about this product, call:

1-800-659-5917

Sears Craftsman Help Line

5 am - 5 pm, Mon - Sat

Sears, Roebuck and Co., Hoffman Estates, IL 60179 U.S.A.

Visit our Craftsman website: www.sears.com/craftsman

7103268
Revision B

Thank You for purchasing this quality-built Craftsman product. We're pleased that you placed your confidence in our brand. When operated and maintained according to the instructions in this manual, your Craftsman product will provide many years of dependable service.

This manual contains safety information to make you aware of the hazards and risks associated with the machine and how to avoid them. This machine is designed and intended only for finish cutting of established lawns and is not intended for any other purpose. It is important that you read and understand these instructions thoroughly before attempting to start or operate this equipment. **Save these instructions for future reference.**

IDENTIFICATION NUMBERS

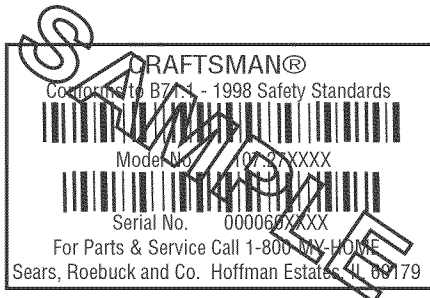

PRODUCT REFERENCE DATA	
Model Description Name/Number	
Stock Number	Unit Serial Number
Date Purchased	
ENGINE REFERENCE DATA	
Engine Maker	Engine Model
Engine Type/Spec	Engine Code/Serial Number

When contacting the service center for replacement parts, service, or information you MUST have these numbers.

Record your model name/number, manufacturer's identification numbers, and engine serial numbers in the space provided for easy access.

The identification tag is located on the rear frame, between the wheels.

For answers to your questions about this product, call the Sears Craftsman Help Line at 1-800-659-5917, between 5 am - 5 pm, Monday-Saturday.

TABLE OF CONTENTS

Identification Numbers	2	Maintenance	17
Warranty Statement	3	Storage	21
Emissions Statement	4	Troubleshooting	22
Operator Safety	5	Specifications	24
Features and Controls	10	Service Parts	PTS-1
Operation	11		

WARRANTY

CRAFTSMAN FULL WARRANTY

When operated and maintained according to all supplied instructions, if any non-expendable part of this riding equipment fails due to a defect in material or workmanship within two years from the date of purchase, call 1-800-659-5917 to arrange for free in-home repair.

The frame and front axle will be repaired free of charge for five years from the date of purchase if defective in material or workmanship.

All of the above warranty coverage applies for only 90 days from the date of purchase if this riding equipment is ever used for commercial or rental purposes.

In all cases, if repair proves impossible, the riding equipment will be replaced free of charge with the same or an equivalent model.

The battery will be replaced free of charge for 90 days from the date of purchase if defective in material or workmanship (or testing proves that it will not hold a charge).

This warranty covers ONLY defects in material and workmanship. Sears will NOT pay for:

- Expendable items that become worn during normal use, including but not limited to blades, spark plugs, air cleaners, belts, and oil filters.
- Standard maintenance servicing, oil changes, or tune-ups.
- Tire replacement or repair caused by punctures from outside objects, such as nails, thorns, stumps, or glass.
- Tire or wheel replacement or repair resulting from normal wear, accident, or improper operation or maintenance.
- Repairs necessary because of operator abuse, including but not limited to damage caused by towing objects beyond the capability of the riding equipment, impacting objects that bend the frame or crankshaft, or over-speeding the engine.
- Repairs necessary because of operator negligence, including but not limited to, electrical and mechanical damage caused by improper storage, failure to use the proper grade and amount of engine oil, failure to keep the deck clear of flammable debris, or failure to maintain the riding equipment according to the instructions contained in the operator's manual.
- Engine (fuel system) cleaning or repairs caused by fuel determined to be contaminated or oxidized (stale). In general, fuel should be used within 30 days of its purchase date.
- Normal deterioration and wear of the exterior finishes, or product label replacement.

This warranty applies only while this product is within the United States.

This warranty gives you specific legal rights, and you may also have other rights which vary from state to state.

Sears, Roebuck and Co., Hoffman Estates, IL 60179

Emissions Control System Warranty Statement

Briggs & Stratton Corporation (B&S), the California Air Resource Board (CARB), and the United States Environmental Protection Agency (U.S. EPA) Emissions Control System Warranty Statement (Owner's Defect Warranty Rights and Obligations)

California, United States and Canada Emissions Control Defects Warranty Statement

The California Air Resource Board (CARB), U.S. EPA and B&S are pleased to explain the Emissions Control System Warranty on your small off-road engine (SORE). In California, new small off-road engines model year 2006 and later must be designed, built and equipped to meet the State's stringent anti-smog standards. Elsewhere in the United States, new non-road, spark-ignition engines certified for model year 1997 and later must meet similar standards set forth by the U.S. EPA. B&S must warrant the emissions control system on your engine for the periods of time listed below, provided there has been no abuse, neglect or improper maintenance of your small off-road engine.

Your emissions control system includes parts such as the carburetor, air cleaner, ignition system, fuel line, muffler and catalytic converter. Also included may be connectors and other emissions related assemblies.

Where a warrantable condition exists, B&S will repair your small off-road engine at no cost to you including diagnosis, parts and labor.

Briggs & Stratton Emissions Control Defects Warranty Coverage

Small off-road engines are warranted relative to emissions control parts defects for a period of two years, subject to provisions set forth below. If any covered part on your engine is defective, the part will be repaired or replaced by B&S.

Owner's Warranty Responsibility

As the small off-road engine owner, you are responsible for the performance of the required maintenance listed in your Operating and Maintenance Instructions. B&S recommends that you retain all your receipts covering maintenance on your small off-road engine, but B&S cannot deny warranty solely for the lack of receipts or for your failure to ensure the performance of all scheduled maintenance.

As the small off-road engine owner, you should however be aware that B&S may deny you warranty coverage if your small off-road engine or a part has failed due to abuse, neglect, improper maintenance or unapproved modifications.

You are responsible for presenting your small off-road engine to an Authorized B&S Service Dealer as soon as a problem exists. The undisputed warranty repairs should be completed in a reasonable amount of time, not to exceed 30 days.

If you have any questions regarding your warranty rights and responsibilities, you should contact a B&S Service Representative at (414) 259-5262.

The emissions warranty is a defects warranty. Defects are judged on normal engine performance. The warranty is not related to an in-use emissions test.

Briggs & Stratton Emissions Control Defects Warranty Provisions

The following are specific provisions relative to your Emissions Control Defects Warranty Coverage. It is in addition to the B&S engine warranty for non-regulated engines found in the Operating and Maintenance Instructions.

1. Warranted Parts

Coverage under this warranty extends only to the parts listed below (the emissions control systems parts) to the extent these parts were present on the engine purchased.

- a. Fuel Metering System
 - Cold start enrichment system (soft choke)
 - Carburetor and internal parts
 - Fuel pump
 - Fuel line, fuel line fittings, clamps
 - Fuel tank, cap and tether
 - Carbon canister
- b. Air Induction System
 - Air cleaner
 - Intake manifold
 - Purge and vent line
- c. Ignition System
 - Spark plug(s)
 - Magneto ignition system
- d. Catalyst System
 - Catalytic converter
 - Exhaust manifold
 - Air injection system or pulse valve
- e. Miscellaneous Items Used in Above Systems
 - Vacuum, temperature, position, time sensitive valves and switches
 - Connectors and assemblies

2. Length of Coverage

B&S warrants to the initial owner and each subsequent purchaser that the Warranted Parts shall be free from defects in materials and workmanship which caused the failure of the Warranted parts for a period of two years from the date the engine is delivered to a retail purchaser.

3. No Charge

Repair or replacement of any Warranted Part will be performed at no charge to the owner, including diagnostic labor which leads to the determination that a Warranted Part is defective, if the diagnostic work is performed at an Authorized B&S Service Dealer as listed in the "Yellow Pages" under "Engines, Gasoline," "Gasoline Engines," "Lawn Mowers," or similar category.

4. Claims and Coverage Exclusions

Warranty claims shall be filed in accordance with the provisions of the B&S Engine Warranty Policy. Warranty coverage shall be excluded for failures of Warranted Parts which are not original B&S parts or because of abuse, neglect or improper maintenance as set forth in the B&S Engine Warranty Policy. B&S is not liable to cover failures of Warranted Parts caused by the use of add-on, non-original, or modified parts.

5. Maintenance

Any Warranted Part which is not scheduled for replacement as required maintenance or which is scheduled only for regular inspection to the effect of "repair or replace as necessary" shall be warranted as to defects for the warranty period. Any Warranted Part which is scheduled for replacement as required maintenance shall be warranted as to defects only for the period of time up to the first scheduled replacement for that part. Any replacement part that is equivalent in performance and durability may be used in the performance of any maintenance or repairs. The owner is responsible for the performance of all required maintenance, as defined in the B&S Operating and Maintenance Instructions.

6. Consequential Coverage

Coverage hereunder shall extend to the failure of any engine components caused by the failure of any Warranted Part still under warranty.

Look For Relevant Emissions Durability Period and Air Index Information On Your Engine Emissions Label

Engines that are certified to meet the California Air Resources Board (CARB) Emissions Standard must display information regarding the Emissions Durability period and the Air Index. Briggs & Stratton makes this information available to the consumer on our emissions labels. The engine emissions label will indicate certification information.

The **Emissions Durability Period** describes the number of hours of actual running time for which the engine is certified to be emissions compliant, assuming proper maintenance in accordance with the Operating and Maintenance Instructions. The following categories are used:

Moderate:

Engine is certified to be emissions compliant for 125 hours of actual running time.

Intermediate:

Engine is certified to be emissions compliant for 250 hours of actual running time.

Extended:

Engine is certified to be emissions compliant for 500 hours of actual engine running time. For example, a typical walk-behind lawn mower is used 20 to 25 hours per year. Therefore, the **Emissions Durability Period** of an engine with an **intermediate** rating would equate to 10 to 12 years.

Briggs & Stratton engines are certified to meet the United States Environmental Protection Agency (ESEPA) Phase 2 emissions standards. For Phase 2 certified engines, the Emissions Compliance Period referred to on the Emissions Compliance label indicates the number of operating hours for which the engine has been shown to meet Federal emissions requirements.

For engines less than 225 cc displacement.

Category C= 125 hours, Category B= 250 hours, Category A= 500 hours

For engines of 225 cc or more displacement.

Category C= 250 hours, Category B= 500 hours, Category A= 1000 hours

OPERATOR SAFETY

Important Safety Instructions

SAVE THESE INSTRUCTIONS - This manual contains important instructions that should be followed during the initial set-up, the operation, and the maintenance of the equipment.

Safety Symbols and Meanings



FIRE



MOVING PARTS



SHOCK



STOP



TOXIC FUMES



KICKBACK



EXPLOSION



ON OFF



WEAR EYE PROTECTION



HAZARDOUS CHEMICAL



HOT SURFACE



CHOKER



READ MANUAL



FAST



SLOW





OIL





FUEL

 The safety alert symbol is used to identify safety information about information about hazards that can result in personal injury. A signal word (DANGER, WARNING, or CAUTION) is used with the alert symbol to indicate the likelihood and the potential severity of injury. In addition, a hazard symbol may be used to represent the type of hazard.

 **DANGER** indicates a hazard which, if not avoided, will result in death or serious injury.

 **WARNING** indicates a hazard which, if not avoided, could result in death or serious injury.



 **CAUTION** indicates a hazard which, if not avoided, could result in minor or moderate injury.

 **NOTICE** indicates a situation that could result in damage to the product.

 **WARNING** The engine exhaust from this product contains chemicals known to the State of California to cause cancer, birth defects, or other reproductive harm.

 **WARNING** Certain components in this product and its related accessories contain chemicals known to the State of California to cause cancer, birth defects, or other reproductive harm. Wash hands after handling.

 **WARNING** Battery posts, terminals, and related accessories contain lead and lead compounds - chemicals known to the State of California to cause cancer, birth defects, or other reproductive harm. Wash hands after handling.

 **WARNING** Running engine gives off carbon monoxide, an odorless, colorless, poison gas.  Breathing carbon monoxide can cause headache, fatigue, dizziness, vomiting, confusion, seizures, nausea, fainting or death.

- Operate equipment **ONLY** outdoors.
- Keep exhaust gas from entering a confined area through windows, doors, ventilation intakes, or other openings.

WARNING: This cutting machine is capable of amputating hands and feet and can throw objects that can cause injury and damage! Failure to comply with the following SAFETY instructions could result in serious injury or death to the operator or bystanders. The owner of the machine must understand these instructions and must allow only persons who understand these instructions to operate machine. Each person operating the machine must be of sound mind and body and must not be under the influence of any substance, which might impair vision, dexterity or judgment.

Protection for Children

Tragic accidents can occur if the operator is not alert to the presence of children. Children are often attracted to the machine and the mowing activity. Never assume that children will remain where you last saw them.

1. KEEP children out of the mowing area and under the watchful care of a responsible adult.
2. DO NOT allow children or others to ride on machine, attachments or towed equipment (even with the blades OFF). They may fall and be seriously injured.
3. ALLOW only responsible adults & teenagers with mature judgment under close adult supervision to operate machine.
4. DO NOT operate blades in reverse. STOP BLADES. LOOK and SEE behind and down for children, pets and hazards before and while backing.
5. USE EXTRA CARE when approaching blind corners, shrubs, trees, or other objects that may obscure vision.

Protection against Tipovers

Slopes are a major factor related to loss-of-control and tip-over accidents, which can result in severe injury or death. All slopes require extra CAUTION. If you cannot back up the slope or if you feel uneasy on the slope, DO NOT mow it. Use extra care with grass catchers or other attachments; these affect the handling and the stability of the machine. Refer to the Slope Guide at the end of this section.

1. DO NOT operate machine on slopes exceeding 10 degrees, which is 3.5 feet (1.1 m) vertically for every 20 feet (6.1 m) horizontally.
2. Turn blades OFF when traveling uphill. Use a slow speed and avoid sudden or sharp turns.
3. DO NOT operate machine back and forth across face of slopes. Operate up and down. Practice on slopes with blades off.
4. AVOID starting, stopping or turning on slopes. If machine stops going uphill or tires lose traction, turn blades OFF and back slowly straight down the slope.
5. STAY ALERT for holes and other hidden hazards. Tall grass can hide obstacles. Keep away from ditches, washouts, culverts, fences and protruding objects.
6. KEEP A SAFE DISTANCE of at least 3 feet (.9 meters) away from edge of ditches and other drop offs. The machine could turn over if an edge caves in.
7. Always begin forward motion slowly and with caution.
8. Use weights or a weighted load carrier in accordance with instructions supplied with a grass catcher. DO NOT operate machine on slopes exceeding 10 degrees.

9. DO NOT put your foot on the ground to try to stabilize the machine.
10. DO NOT operate machine on wet grass. Reduced traction could cause sliding.
11. Choose a low enough speed setting so that you will not have to stop or shift on a slope. Tires may lose traction on slopes even though the brakes are functioning properly.
12. DO NOT operate machine under any condition where traction, steering or stability is doubtful.
13. Always keep the machine in gear when going down slopes. DO NOT shift to neutral (or actuate hydro roll release) and coast downhill.

Before Mowing

1. Read, understand, and follow instructions and warnings in this manual and on the machine, engine and attachments. Know the controls and the proper use of the machine before starting.
2. Only mature, responsible persons shall operate the machine and only after proper instruction.
3. Data indicates that operators age 60 and above, are involved in a large percentage of mower-related injuries. These operators should evaluate their ability to operate the mower safely enough to protect themselves and others from serious injury.
4. Handle fuel with extra care. Fuels are flammable and vapors are explosive. Use only an approved fuel container. DO NOT remove fuel cap or add fuel with engine running. Add fuel outdoors only with engine stopped and cool. Clean spilled fuel from machine. DO NOT smoke.
5. Practice operation of machine with BLADES OFF to learn controls and develop skills.
6. Check the area to be mowed and remove all objects such as toys, wire, rocks, limbs and other objects that could cause injury if thrown by blade or interfere with mowing.
7. Keep people and pets out of mowing area. Immediately STOP blades, STOP engine, and STOP machine if anyone enters the area.
8. Check shields, deflectors, switches, blade controls and other safety devices frequently for proper operation and location.
9. Make sure all safety decals are clearly legible. Replace if damaged.
10. Protect yourself when mowing by wearing safety glasses, a dust mask, long pants and substantial footwear.

11. Know how to STOP blades and engine quickly in preparation for emergencies.
12. Use extra care when loading or unloading the machine into a trailer or truck.
13. Check grass catcher components frequently for signs of wear or deterioration and replace as needed to prevent injury from thrown objects going through weak or worn spots.

Safe Handling of Gasoline

To avoid personal injury or property damage, use extreme care in handling gasoline. Gasoline is extremely flammable and the vapors are explosive.

1. Extinguish all cigarettes, cigars, pipes and other sources of ignition.
2. Use only an approved fuel container.
3. DO NOT remove fuel cap or add fuel with the engine running. Allow the engine to cool before refueling.
4. DO NOT refuel the machine indoors.
5. DO NOT store the machine or fuel container inside where there is an open flame, spark or pilot light such as on a water heater or other appliances.
6. DO NOT fill fuel containers inside a vehicle or on a truck or trailer bed with a plastic liner. Always place the containers on the ground away from the vehicle before filling.
7. Remove gas-powered equipment from the vehicle or trailer and refuel it on the ground. If this is not possible, then refuel equipment using a portable container, rather than a gasoline dispenser nozzle.
8. DO NOT start gas powered equipment in enclosed vehicles or trailers.
9. Keep the nozzle in contact with the rim of the fuel tank or container opening at all times until fueling is complete. DO NOT use a nozzle lock-open device
10. If fuel is spilled on clothing, change clothing immediately.
11. Never overfill a fuel tank. Replace fuel cap and tighten securely.

General Operating Safety

1. Mount and dismount machine from left side. Keep clear of discharge opening at all times.
2. Start engine from operator's seat. Make sure blades are OFF and parking brake is set.
3. DO NOT leave machine with engine running. STOP engine, STOP blades, SET brake, and Remove key before leaving operators position of any reason.
4. DO NOT operate machine unless properly seated with feet on rests or pedal(s).
5. STOP BLADES and ENGINE and make sure blades have stopped before removing grass catcher or unclogging mower to prevent loss of fingers or hand.
6. Blades must be OFF except when cutting grass. Set blades in highest position when mowing over rough ground.
7. Keep hands and feet away from rotating blades underneath deck. DO NOT place foot on ground while BLADES are ON or machine is in motion.
8. DO NOT operate machine without entire grass catcher or guards in place and working. DO NOT point discharge at people, passing cars, windows or doors.
9. Slow down before turning.
10. Watch out for traffic when near or crossing roadways.
11. STOP engine immediately after striking an obstruction. Inspect machine and repair damage before resuming operation.
12. Operate machine only in daylight or with good artificial light.
13. Move joystick (if equipped) SLOWLY to maintain control during speed and directional changes.
14. DO NOT operate engine in enclosed areas. Engine exhaust gases contain carbon monoxide, a deadly poison.
15. DO NOT discharge material against a wall or obstruction. Material may ricochet back towards the operator.
16. Only use accessories approved by the manufacturer. See manufacturer's instructions for proper operation and installation of accessories.

Towing

1. Tow only with a machine that has a hitch designed for towing. DO NOT attach towed equipment except at the hitch point.
2. Follow the manufacturer's recommendation for weight limits for towed equipment and towing on slopes.
3. DO NOT allow children or others on towed equipment.
4. On slopes, the weight of the towed equipment may cause loss of traction and loss of control.
5. Travel slowly and allow extra distance to stop.
6. Exercise CAUTION when pulling loads. Limit loads to those you can safely control and attach loads to hitch plate as specified in the attachment instructions.
7. Service engine and make adjustments only when engine is stopped. Remove spark plug wire(s) from spark plug(s) and secure wire(s) away from spark plug(s).
8. DO NOT change engine governor speed settings or overspeed engine.
9. Mower blades are sharp and can cut. Wrap the blades or wear heavy leather gloves and use CAUTION when handling them.
10. DO NOT test for spark by grounding spark plug next to spark plug hole; spark plug could ignite gas exiting engine.
11. Maintain or replace safety and instruction labels as necessary.

Maintenance Safety

1. DO NOT store machine or fuel container inside where fumes may reach an open flame, spark or pilot light such as in a water heater, furnace, clothes dryer or other gas appliance. Allow engine to cool before storing machine in an enclosure. Store fuel container out of the reach of children in a well ventilated, unoccupied building.
2. Keep engine free of grass, leaves or excess grease to reduce fire hazard and engine overheating.
3. When draining fuel tank, drain fuel into an approved container outdoors and away from open flame.
4. Always provide adequate ventilation when running engine. Exhaust gases contain carbon monoxide, an odorless and deadly poison.
5. Disconnect negative (black) cable from battery before performing maintenance or service. Cranking engine could cause injury.
6. DO NOT work under machine without safety blocks.

SUGGESTED GUIDE FOR SIGHTING SLOPES FOR SAFE OPERATION

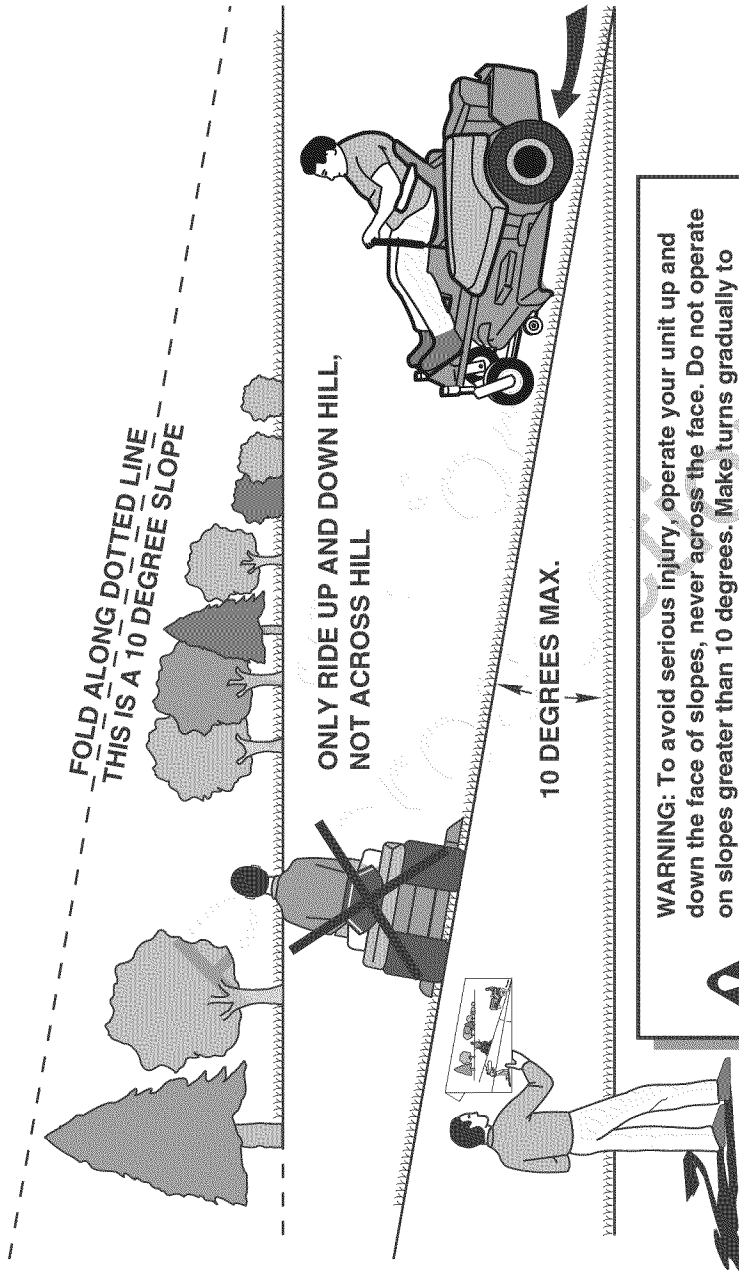

WARNING: To avoid serious injury, operate your unit up and down the face of slopes, never across the face. Do not operate on slopes greater than 10 degrees. Make turns gradually to prevent tipping or loss of control. Exercise extreme caution when changing direction on slopes. Braking may be affected by attachments. Reduce speed on slopes.

1. Fold this page along dotted line indicated above.
2. Hold page before you so that its left edge is vertically parallel to a tree trunk or other upright structure.
3. Sight across the fold in the direction of hill slope you want to measure.
4. Compare the angle of the fold with the slope of the hill.

FEATURES AND CONTROLS

NOTICE: The figures and illustrations in this manual are provided for reference only and may differ from your specific model.

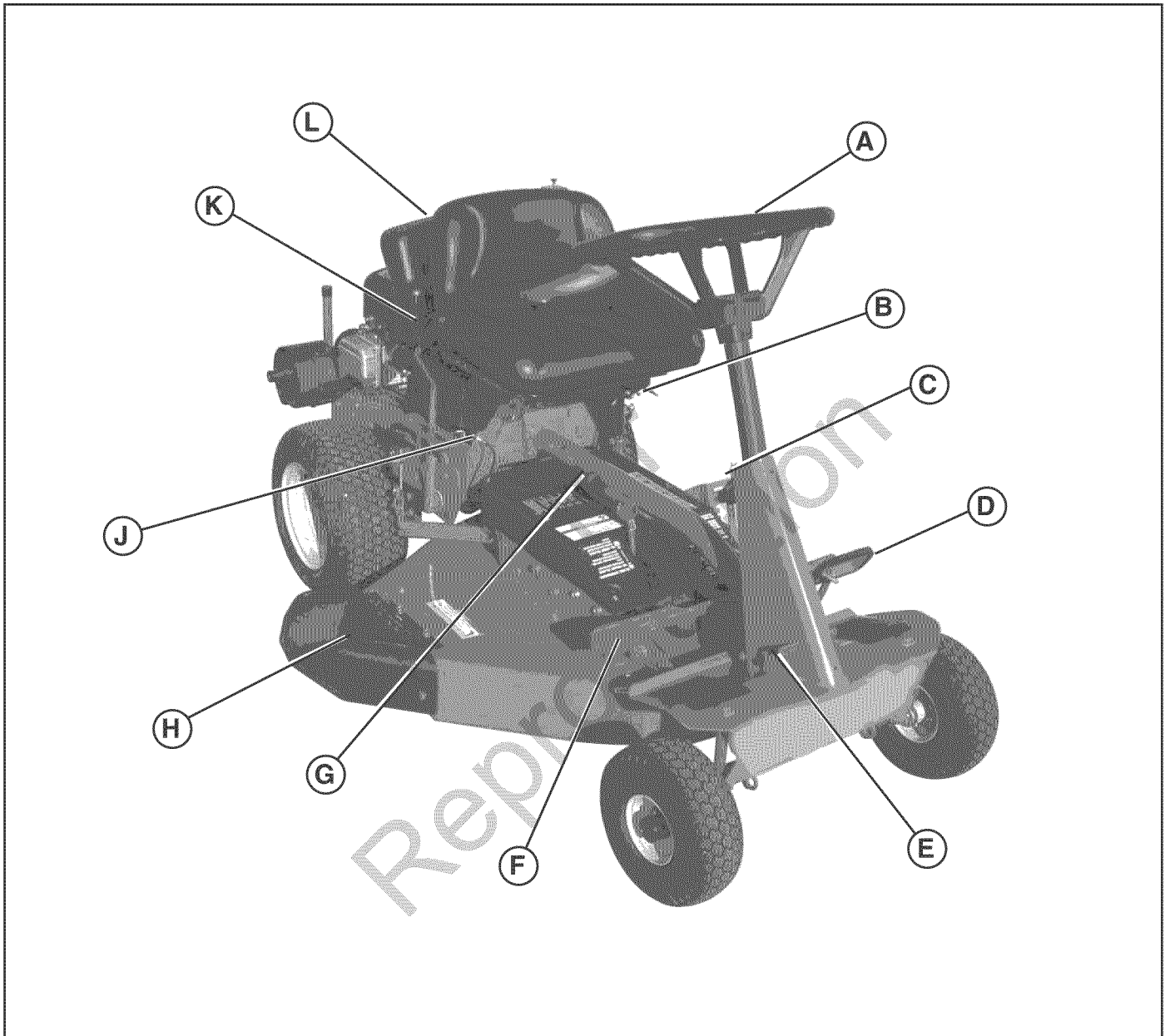

- | | | | |
|----|---|----|--------------------------|
| A. | Steering Wheel | F. | Blade Pedal |
| B. | Engine Speed Control (hidden from view) | G. | Blade Lever |
| C. | Ignition Switch | H. | Discharge Deflector |
| D. | Clutch/Brake Pedal | J. | Override Control |
| E. | Parking Brake Latch | K. | Transmission Shift Lever |
| | | L. | Fuel Tank |

OPERATION

Oil Recommendations

We recommend the use of Briggs & Stratton Warranty Certified oils for best performance. Other high-quality detergent oils are acceptable if classified for service SF, SG, SH, SJ or higher. Do not use special additives.

Outdoor temperatures determine the proper oil viscosity for the engine. Use the chart to select the best viscosity for the outdoor temperature range expected.

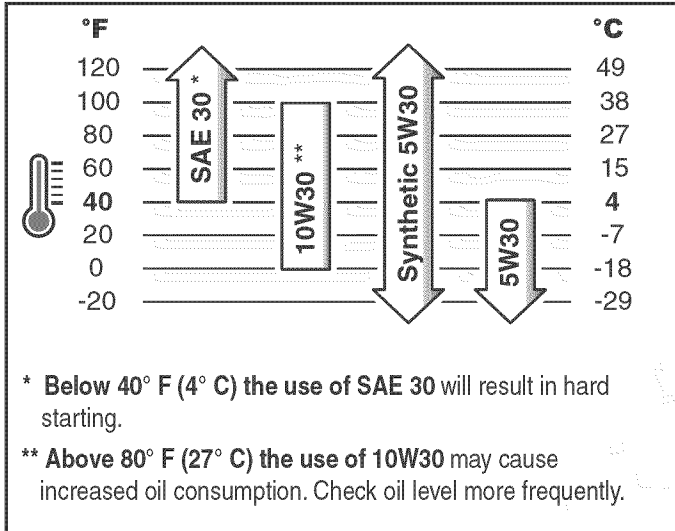

How to Check/Add Oil

1. Remove the dipstick and wipe with a clean cloth.
2. Insert and tighten the dipstick.
3. Remove the dipstick and check the oil level. It should be at the top of the full indicator on the dipstick.
4. If low, add oil slowly into the engine oil fill. **Do not overfill.** After adding oil, wait one minute and then recheck the oil level.
5. Replace and tighten the dipstick.

Fuel Recommendations

Fuel must meet these requirements:

- Clean, fresh, unleaded gasoline
- A minimum of 87 octane/87 AKI (91 RON). High altitude use, see below.
- Gasoline with up to 10% ethanol (gasohol) or up to 15% MTBE (methyl tertiary butyl ether) is acceptable.

CAUTION: Do not use unapproved gasolines, such as E85. Do not mix oil in gasoline or modify the engine to run on alternate fuels. This will damage the engine components and **void the engine warranty.**

To protect the fuel system from gum formation, mix a fuel stabilizer into the fuel. See Storage. All fuel is not the same. If starting or performance problems occur, change the fuel providers or change brands. This engine is certified to operate on gasoline. The emissions control system for the engine is EM (Engine Modifications).

High Altitude

At altitudes over 5,000 feet (1524 meters), a minimum 85 octane/85 AKI (89 RON) gasoline is acceptable. To remain emissions compliant, high altitude adjustment is required. Operation without this adjustment will cause decreased performance, increased fuel consumption, and increased emissions. See a Craftsman Service Dealer for high altitude adjustment information.

Operation of the engine at altitudes below 2,500 feet (762 meters) with the high altitude kit is not recommended.

How to Add Fuel

⚠ WARNING Gasoline and its vapors are extremely flammable and explosive.
Fire or explosion can cause severe burns or death.



When Adding Fuel

- Turn engine off and let engine cool at least 2 minutes before removing the fuel cap.
- Fill fuel tank outdoors or in well-ventilated area.
- Do not overfill fuel tank. To allow for expansion of gasoline, do not fill above the bottom of the fuel tank neck.
- Keep gasoline away from sparks, open flames, pilot lights, heat, and other ignition sources.
- Check fuel lines, tank, cap, and fittings frequently for cracks or leaks. Replace if necessary.
- If fuel spills, wait until it evaporates before starting engine.

1. Add fuel to the fuel tank after pushing the machine outside where fumes can dissipate. Make sure the fuel filler cap (A, Figure 1) is tight, and the vent (B) is open after refueling. If the vent is not opened, the engine will stall.

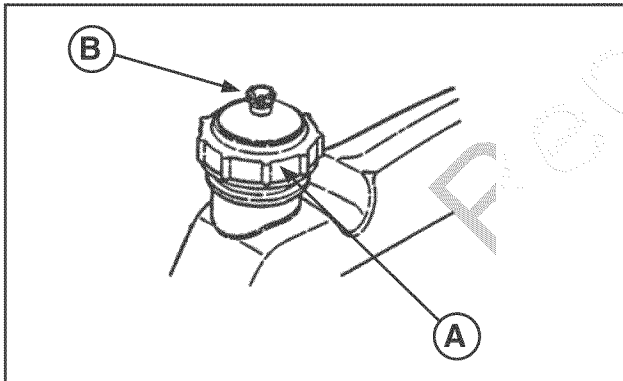

FIGURE 1

Before Starting

1. Check the tire pressure; add or release air as needed to bring pressure to values listed on Specifications page.
2. Check guards, deflectors and covers to make sure all are in place and securely tightened.
3. Check engine oil and add oil as needed to bring level up to the FULL mark (A, Figure 2).

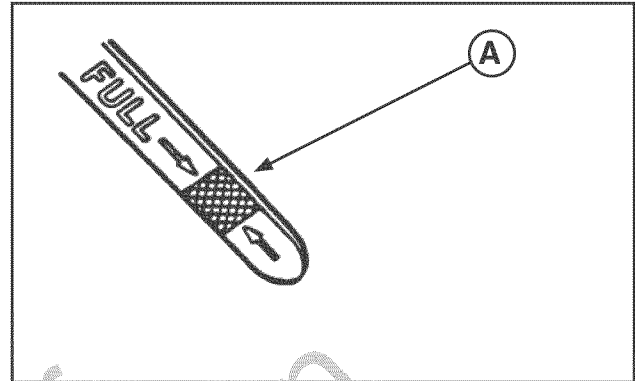

FIGURE 2

4. With the engine stopped, loosen the two adjusting knobs (B, Figure 3) and move the seat to the desired position. After adjustment, tighten the knobs securely.
5. Check the blade lever mechanism. If the blade pedal is depressed, the blade lever can be moved manually from ON to OFF to stop the blade.
6. Check the Reverse Lockout Mechanism. With the blade pedal depressed, the transmission shift lever must **not** go into reverse.

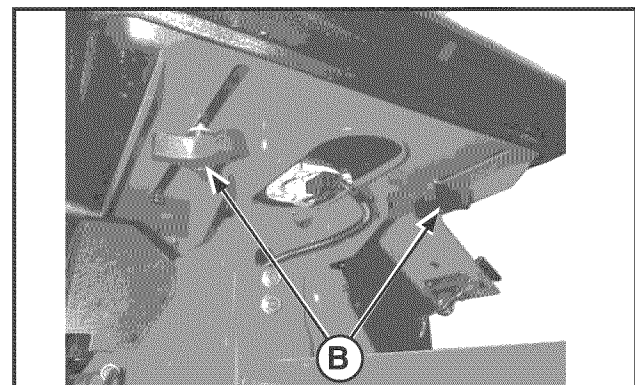

FIGURE 3

How to Start the Engine

⚠ WARNING Gasoline and its vapors are extremely flammable and explosive.
Fire or explosion can cause severe burns or death.



When Starting Engine

- Ensure that spark plug, muffler, fuel cap and air cleaner (if equipped) are in place and secured.
- Do not crank the engine with the spark plug removed.
- If engine floods, set choke (if equipped) to OPEN/RUN position, move throttle (if equipped) to FAST position and crank until engine starts.

⚠ WARNING Running engine gives off carbon monoxide, an odorless, colorless, poison gas.
Breathing carbon monoxide can cause headache, fatigue, dizziness, vomiting, confusion, seizures, nausea, fainting or death.

- Operate equipment **ONLY** outdoors.
- Keep exhaust gas from entering a confined area through windows, doors, ventilation intakes, or other openings.

⚠ WARNING DO NOT start the engine with the transmission shift lever in a drive position. Follow starting instructions carefully.

IMPORTANT: When the ignition key is turned to START, the engine will turn over, but will not start unless the clutch/brake pedal is pressed all the way down, and the blade lever is OFF. The operator must be in the seat.

1. Move the transmission shift lever (**A**, Figure 4) to the (N) NEUTRAL position.
2. Make sure the blade lever (**A**, Figure 5) is in the OFF position.
3. Press the clutch/brake pedal (Figure 6) all the way down and hold while starting the engine.

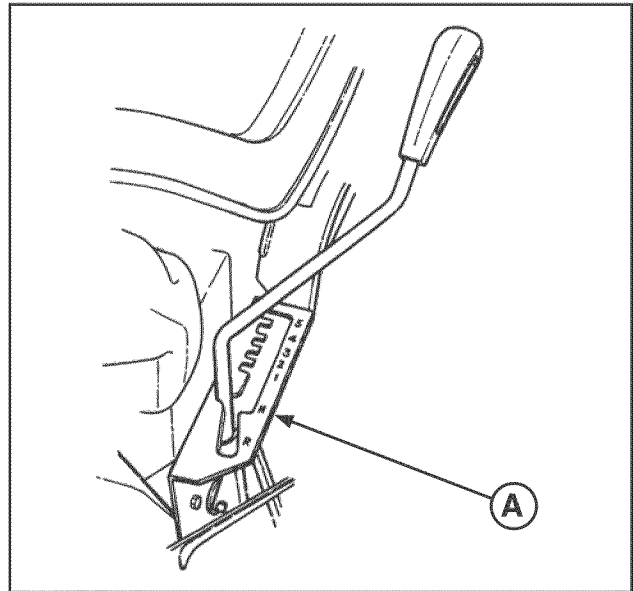

FIGURE 4

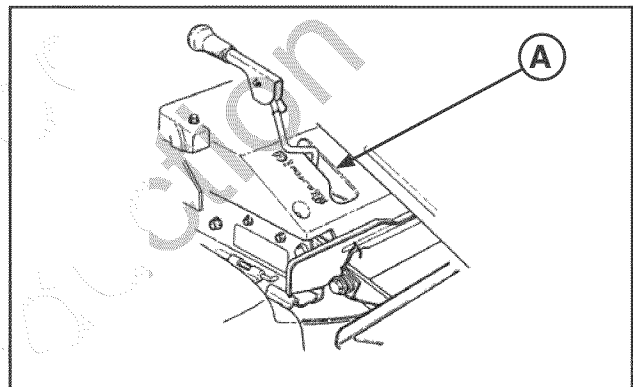

FIGURE 5

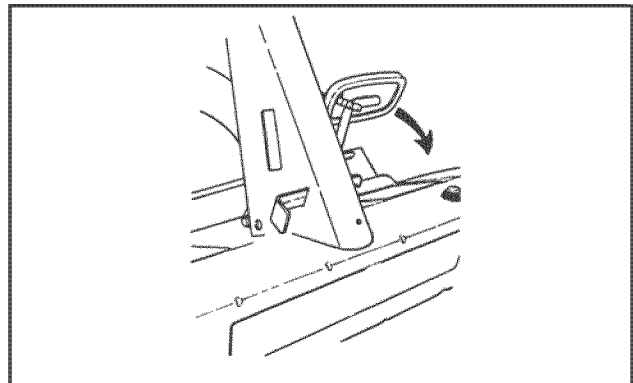

FIGURE 6

4. Move the engine speed control (Figure 7) to the CHOKE position to start a cold engine.
5. Turn the ignition key (Figure 8) to the START position until the engine starts.

NOTE: If after 5 seconds of cranking the engine does not start, release the key, make sure the clutch/brake pedal is fully depressed, and attempt starting again after waiting for approximately 20 seconds.

6. After the engine starts, move the engine speed control to the FAST position and allow a brief warm-up until engine runs smooth.

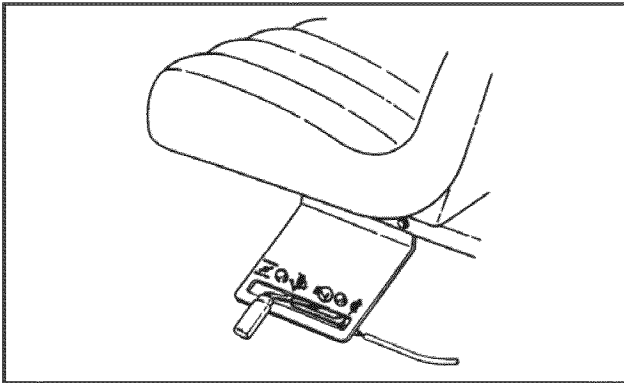

FIGURE 7

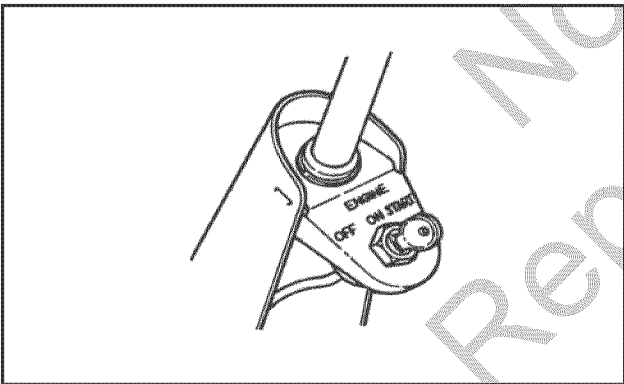

FIGURE 8

⚠ WARNING DO NOT leave the machine with the engine running. STOP blade. STOP engine. Shift to neutral and engage parking brake. Remove key.

7. Turn the ignition key (Figure 8) to the OFF position to stop the engine.

How to Operate the Mower Blade

1. To engage the blade, move the blade lever (A, Figure 9) to ON position, then depress the blade pedal (B) to hold the blade lever in the ON position.
2. To stop the blade, release the blade pedal. The blade lever will return to the OFF position.

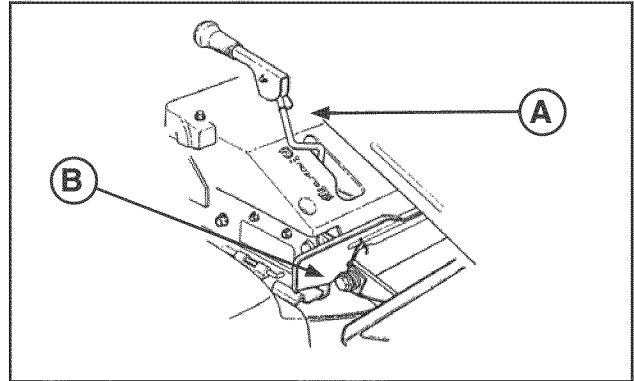

FIGURE 9

⚠ WARNING If blade does not come to a complete stop in 3 seconds or less, the blade brake must be adjusted. DO NOT operate machine until proper adjustment has been performed by an authorized service dealer

How to Set the Cutting Height

1. Adjust the cutting height by raising or lowering the deck lift lever (A, Figure 10) into the desired height of cut notch (B).
2. When mowing is completed, set the deck lift lever to the highest position, then stop the blade.

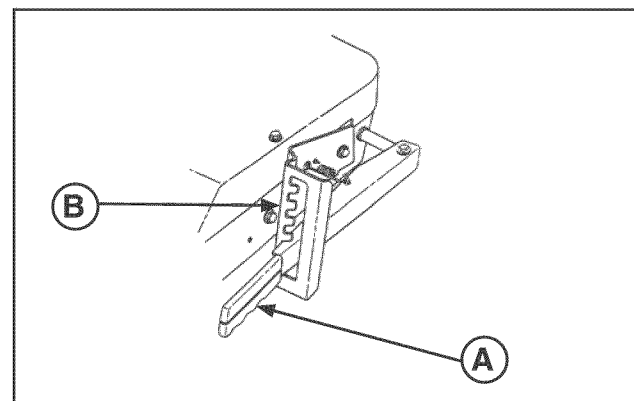

FIGURE 10

How to Engage the Drive System

⚠ WARNING DO NOT operate blades in reverse. STOP BLADES. LOOK and SEE behind and down for children, pets and hazards before and while backing.

1. Fully depress the clutch/brake pedal (Figure 11).
2. Place the transmission shift lever (B, Figure 12) into the first forward speed notch (C).

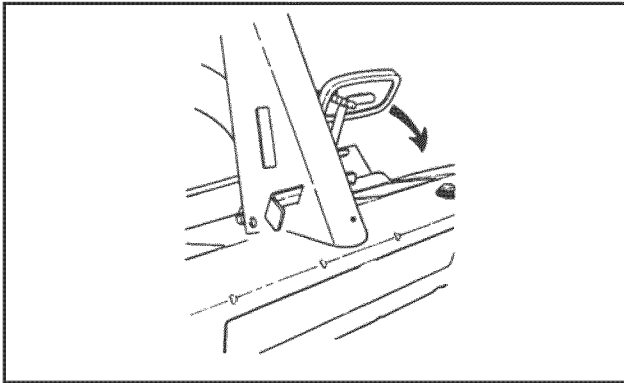

FIGURE 11

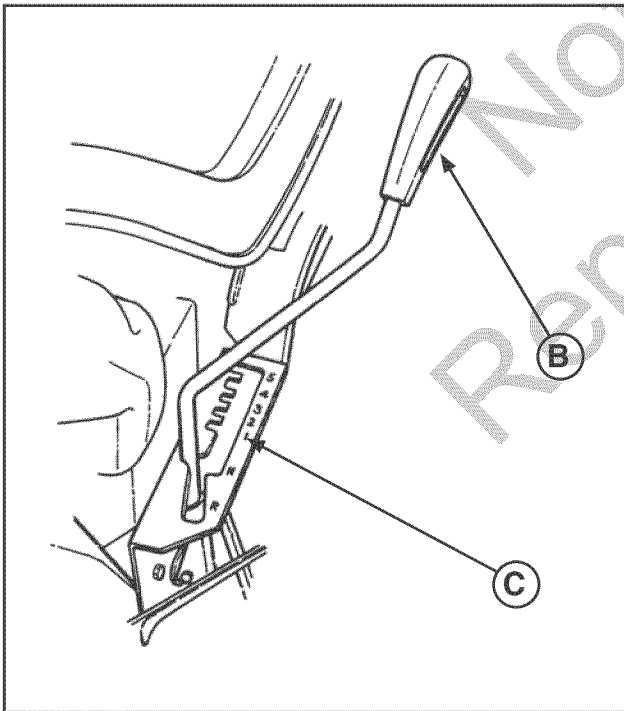

FIGURE 12

3. Smoothly release the clutch/brake pedal to begin forward motion.
4. During forward motion, the transmission shift lever may be placed in any desired forward speed without depressing the clutch/brake pedal.
5. To stop the machine, fully depress the clutch/brake pedal. Shift to the Neutral (N) position.

NOTE: For best cutting results, use a slower forward speed with the engine throttle set to FAST. This combination will allow the mower blade to lift the grass while cutting smoothly and evenly.

Reverse Lockout Mechanism

This riding mower has a Reverse Lockout Mechanism. This device prevents the mower from being shifted into reverse while the blade is turning.

1. To shift into reverse, stop the blade by releasing the blade pedal.
2. Fully depress the clutch/brake pedal, then shift into Reverse.
3. After visually clearing the area behind the machine, smoothly release the clutch/brake pedal.

⚠ WARNING DO NOT operate blades in reverse. STOP BLADES. LOOK and SEE behind and down for children, pets and hazards before and while backing.

Reverse Lockout Override



WARNING AMPUTATION HAZARD



Failure to obey these rules could result in loss of control of unit, severe personal injury or death to you, or bystanders, or damage to property or equipment.



- Do not mow when children or others are present.
- Do not carry riders (especially children) even with the blades off. They may fall off or return for another ride when you are not expecting it.
- Look down and behind before and while backing.

This override should never be selected unless you are absolutely sure that no children or others are present in the mowing area.

If the machine is used in areas that require quick shifting to reverse (such as operation near a roadway), the override lever will allow mowing in reverse until the blade pedal is released.

IMPORTANT: DO NOT use the Reverse Lockout Override as the normal operating mode.

1. Stop the machine and the blade.
2. Push down and hold the override lever on the transmission shift bracket.
3. Depress and hold the blade pedal, then release the override lever.
4. Move the blade lever to ON position.
5. Engage the drive system as usual.

When the blade pedal is released, the Reverse Lockout Mechanism is automatically reactivated.

IMPORTANT: DO NOT use the Reverse Lockout Override as the normal operating mode. Check the Reverse Lockout Mechanism frequently for proper function. With the blade pedal depressed, the transmission shift lever must **not** go into reverse. DO NOT operate machine if Reverse Lockout Mechanism is not functioning properly. Contact a Craftsman Service dealer for assistance.

How to Set the Parking Brake

1. To set the parking brake, press the clutch/brake pedal (A, Figure 13) all the way down, slide the parking brake latch (B) all the way in, and release the clutch/brake pedal. A detent in the parking brake latch will keep the parking brake engaged.



WARNING DO NOT park on slopes.

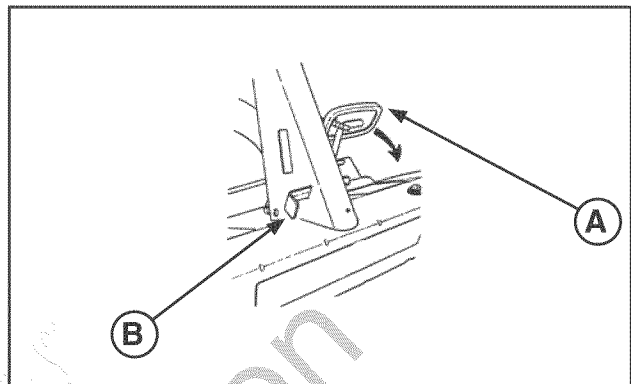

FIGURE 13



2. To release the parking brake, press firmly on the clutch/brake pedal. The parking brake latch will automatically disengage.

MAINTENANCE

Emissions Control

Maintenance, replacement, or repair of the emissions control devices and systems may be performed by any non-road engine repair establishment or individual. However, to obtain “no charge” emissions control service, the work must be performed by a Craftsman or Briggs & Stratton service dealer. See the Emissions Warranty.

WARNING

-  Unintentional sparking can result in fire or electric shock.
-  Unintentional start-up can result in entanglement, traumatic amputation, or laceration.
-  Fire hazard.

Before performing adjustments or repairs:

- Disconnect the spark plug wire and keep it away from the spark plug.
- Disconnect battery at negative terminal.
- Use only correct tools.
- Do not tamper with governor spring, links or other parts to increase engine speed.
- Replacement parts must be the same and installed in the same position as the original parts.
- STOP engine
- STOP blade
- Engage parking brake
- Remove key
- Avoid serious burns. Allow all parts to cool before working on machine.
- Fuel filler cap and vent must be closed securely to prevent fuel spillage.

Equipment Maintenance Chart

TRACTOR AND MOWER
Every 8 Hours or Daily
Check safety interlock system
Clean debris off tractor and mower deck
Clean debris from engine compartment
Every 25 Hours or Annually *
Check tire pressure
Check mower blade stopping time
Check tractor and mower for loose hardware
Every 50 Hours or Annually *
Clean battery and cables
Check tractor brakes
See Dealer Annually to
Lubricate tractor and mower
Check mower blades **

* Whichever comes first

** Check blades more often in regions with sandy soils or high dust conditions.

Engine Maintenance Chart

ENGINE
First 5 Hours
Change engine oil
Every 8 Hours or Daily
Check engine oil level
Every 25 Hours or Annually *
Clean engine air filter and pre-cleaner **
Every 50 Hours or Annually *
Change engine oil
Replace oil filter
Annually
Replace air filter
Replace pre-cleaner
See Dealer Annually to
Inspect muffler and spark arrester
Replace spark plug
Replace fuel filter
Clean engine air cooling system

* Whichever comes first

** Clean more often in dusty conditions or when airborne debris is present.

Check Safety Interlock System

This unit is equipped with safety interlock switches. Do not attempt to bypass safety switches, and never tamper with safety devices.

Operational SAFETY Checks

Test 1 — Engine should NOT crank when:

- Mower blade lever is ON, or
- Transmission is in Forward or Reverse positions, or
- Clutch/brake pedal is released.

Test 2 — Engine SHOULD crank when:

- Mower blade is OFF, and
- Transmission is in Neutral (N) position, and
- Clutch/pedal is fully depressed.

Test 3 — Engine should SHUT OFF when:

- Operator rises off seat with the mower blade ON
- Operator rises off seat with the transmission engaged
- Operator rises off seat with the parking brake OFF.

Test 4 — Check Mower Blade Stopping Time

The mower blade should come to a complete stop within three seconds after the mower blade is turned OFF.

 **WARNING** If blade does not come to a complete stop in 3 seconds or less, the blade brake must be adjusted. DO NOT operate machine until proper adjustment has been performed by an authorized service dealer.

Check Reverse Lockout Mechanism

 **WARNING** If Reverse Lockout Mechanism is not functioning properly, DO NOT operate machine until proper adjustment has been performed by an authorized service dealer.

Check the function of the Reverse Lockout Mechanism with the engine OFF.

1. Depress and hold the blade pedal.
2. Depress and hold the clutch/brake pedal.
3. The transmission shift lever must **not** go into reverse.

Clean Debris Off Tractor, Mower Deck, and Engine Compartment

 **WARNING** Combustible debris, such as leaves, grass, brush, etc can catch fire.

- Remove accumulated debris from muffler area, mower deck, and engine compartment.

Remove any grass clippings, dirt, leaves, or other debris from the unit and engine compartment.

1. Stop engine and allow engine to cool.
2. Remove ignition key, then disconnect sparkplug wire from spark plug.
3. Wear safety goggles. Using a brush and/or compressed air, clean debris from all surfaces of tractor and top of mower deck.
4. Clean engine compartment thoroughly, including any debris from the intake screen on the top of the engine, exposed engine cooling fins, and around the air filter assembly.

Check Tire Pressure

Tire pressure should be checked (Figure 14) periodically, and maintained at the pressures listed on the Specifications page. The pressures shown provide proper traction, improve cut quality, and extend tire life.

NOTE: These pressures may differ from the “Max Inflation” stamped on the side-wall of the tires.

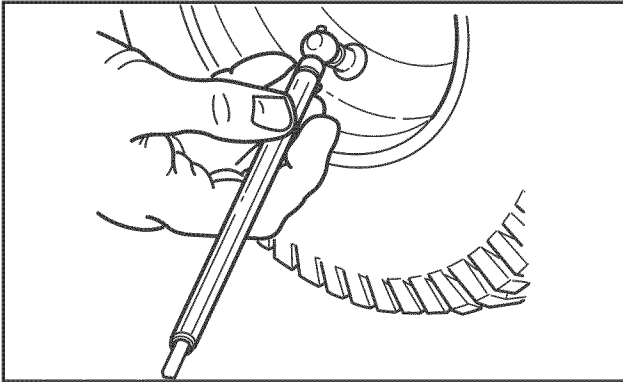

FIGURE 14

Check Mower Blade Stopping Time

WARNING If blade does not come to a complete stop in 3 seconds or less, the blade brake must be adjusted. DO NOT operate machine until proper adjustment has been performed by an authorized service dealer.

Check the blade brake for proper function. The blade should stop rotating in 3 seconds or less after moving the blade control lever to the OFF position or after releasing the blade pedals.

Clean Battery and Cables

WARNING Battery posts, terminals, and related accessories contain lead and lead compounds - chemicals known to the State of California to cause cancer, birth defects, or other reproductive harm. Wash hands after handling.

1. Disconnect the cables from the battery, negative cable first (**A**, Figure 15).
2. Remove the battery.
3. Clean the battery, battery terminals, and battery compartment using a brush with a solution of baking soda and water.
4. Rinse with clean water.
5. Reinstall the battery.
6. Reattach the battery cables: first attach the positive cable (**B**), then attach the negative cable (**A**).
7. Coat the cable ends and battery terminals with petroleum jelly or non-conducting grease.

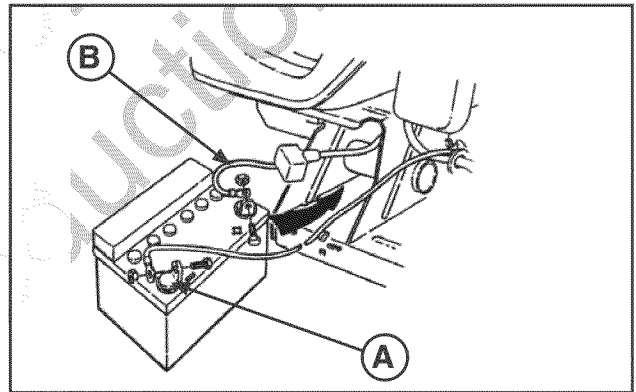

FIGURE 15

Check Tractor Brakes

Check the brakes for proper function. Engage the parking brake, and push the machine. The rear tires should skid. Drive the machine forward and apply the brake. The machine should come to a complete stop in less than 5 ft.

How to Change the Engine Oil

Used oil is a hazardous waste product and must be disposed of properly. Do not discard with household waste. Check with your local authorities, service center, or dealer for safe disposal/recycling facilities.

1. Set the parking brake, then raise the front of the mower slightly by placing wood blocks beneath the front axle.
2. Disconnect the spark plug wire and keep it away from the spark plug.
3. Remove the dipstick and loosen or remove the oil fill cap on the engine.
4. Place an appropriate container under the oil drain (Figure 16). Remove or open the oil drain plug and allow oil to drain completely.
5. If equipped, change the oil filter.
6. Replace or close the drain plug, and wipe up any oil that may have spilled. Dispose of used oil properly.
7. Pour new oil slowly into the engine oil fill. Do not overfill. After adding oil, wait one minute and then check the oil level.
8. Install and tighten the dipstick, then remove the dipstick and check the oil level. It should be at the top of the full indicator.
9. Install and tighten the dipstick.

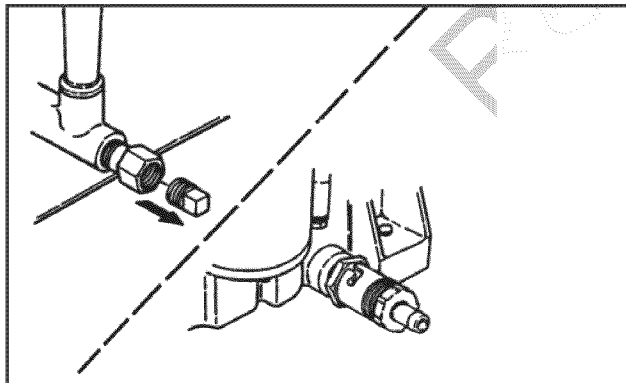

FIGURE 16

How to Service the Air Filter

WARNING Gasoline and its vapors are extremely flammable and explosive.
Fire or explosion can cause severe burns or death.
• Never start or run the engine with the air cleaner assembly or the air filter removed.

NOTICE: Do not use pressurized air or solvents to clean the filter. Pressurized air can damage the filter and solvents will dissolve the filter.

1. Lift up on the bottom of the latch (A, Figure 17) and flip the latch away from the cover (B).
2. Remove the cover. Remove the filter (C) and the pre-cleaner (D).
3. To loosen debris, gently tap the filter on a hard surface. If filter is excessively dirty, replace with a new filter.
4. Wash the pre-cleaner in liquid detergent and water. Then allow it to thoroughly air dry. Do not oil the pre-cleaner.
5. Install the pre-cleaner with the mesh side up. Install the filter.
6. Install the cover making sure the tabs are inserted into their slots. Secure with the latch.

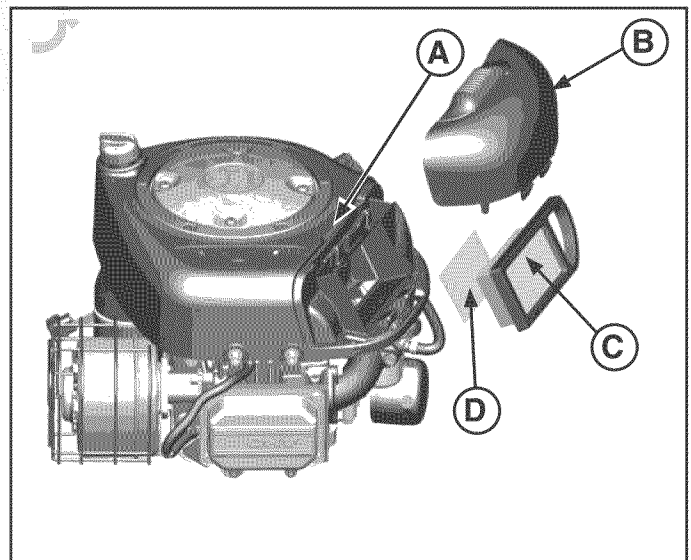

FIGURE 17

STORAGE

Before Storage

Before storing the unit perform the following steps:

1. Turn the mower blade OFF, move the transmission shift lever to Neutral (N), set the parking brake, and remove the key from the ignition switch.
2. Check all fluid levels. Check all maintenance items.
3. Remove battery and store in a cool place. Recharge about once a month. If the battery is left in the unit, disconnect the negative cable.

Protect Fuel System

Fuel can become stale when stored over 30 days. Stale fuel causes acid and gum deposits to form in the fuel system or on essential carburetor parts. To keep fuel fresh, use Briggs & Stratton FRESH START® fuel stabilizer, available as a liquid additive or a drip concentrate cartridge.

There is no need to drain gasoline from the engine if a fuel stabilizer is added according to instructions. Run the engine for 2 minutes to circulate the stabilizer throughout the fuel system. The engine and fuel can then be stored up to 24 months.

If gasoline in the engine has not been treated with a fuel stabilizer, it must be drained into an approved container. Run the engine until it stops from lack of fuel. The use of a fuel stabilizer in the storage container is recommended to maintain freshness.

After Storage

Before starting the unit after it has been stored:

1. Check all fluid levels. Check all maintenance items.
2. Fill with FRESH fuel.
3. After starting, allow the engine to warm before operating.

TROUBLEHOOTING

Troubleshooting the Tractor

PROBLEM	LOOK FOR	REMEDY
Engine will not turnover or start.	Brake pedal not depressed.	Fully depress brake pedal.
	Blade lever is in ON position.	Place blade lever in OFF position.
	Fuel cap vent closed.	Open fuel cap vent.
	Out of fuel.	If engine is hot, allow it to cool, then refill the fuel tank.
	Engine flooded.	Disengage the choke.
	Fuse is blown.	See authorized dealer.
	Battery terminals require cleaning.	See Cleaning the Battery and Cables section.
	Battery discharged or dead.	Recharge or replace battery.
	Wiring loose or broken.	Visually check wiring. If wires are frayed or broken, see authorized dealer.
	Solenoid or starter motor faulty.	See authorized dealer.
	Safety interlock switch faulty.	See authorized dealer.
	Water in fuel.	See authorized dealer.
	Gas is old or stale.	See authorized dealer.
Engine starts hard or runs poorly.	Fuel mixture too rich.	Clean air filter.
	Engine has other problem.	See authorized dealer.
Engine knocks.	Low oil level.	Check/add oil as required.
	Using wrong grade oil.	See Oil Recommendations Chart.
Excessive oil consumption.	Engine running too hot.	See authorized dealer.
	Using wrong grade oil.	See Oil Recommendations Chart.
	Too much oil in crankcase.	Drain excess oil.
Engine exhaust is black.	Dirty air filter.	See Servicing the Air Filter section.
	Choke closed.	Open choke.
Engine runs, but tractor will not drive.	Drive disc worn or out of adjustment.	See authorized dealer.
	Parking brake is engaged.	Disengage parking brake.

Troubleshooting the Tractor

PROBLEM	LOOK FOR	REMEDY
Brake will not hold.	Internal brake worn.	See authorized dealer.
Tractor steers hard or handles poorly.	Steering linkage is loose.	See authorized dealer.
	Improper tire inflation.	See Check Tire Pressure section.
	Front wheel spindle bearings dry.	See authorized dealer.

Troubleshooting the Mower

PROBLEM	LOOK FOR	REMEDY
Mower will not raise.	Lift linkage not properly attached or damaged.	See authorized dealer.
Mower cut is uneven.	Mower not leveled properly.	See authorized dealer.
	Tractor tires not properly inflated.	See Check Tire Pressure section.
Mower cut is rough looking.	Engine speed too slow.	Set to full throttle.
	Ground speed too fast.	Slow down.
	Mower has other problem.	See authorized dealer.
Engine stalls easily with mower engaged.	Engine speed too slow.	Set to full throttle.
	Ground speed too fast.	Slow down.
	Dirty or clogged air filter.	See Servicing Air Filter section.
	Cutting height set too low.	Cut tall grass at maximum cutting height during first pass.
	Discharge chute jamming.	Cut grass with discharge pointing toward previously cut area.
	Engine not up to operating temperature.	Run engine for several minutes to warm-up.
	Starting mower in tall grass.	Start the mower in a cleared area.
Excessive mower vibration.	Damaged cutting blade or deck belt.	See authorized dealer.
Engine runs and tractor drives, but mower will not drive.	Deck belt loose or damaged.	See authorized dealer.

SPECIFICATIONS

Model # 107.280340	
Overall Length	64"
Overall Width	32"
Deck Size (inches)	28"
Height of Cut (5-position)	1.5 - 4.0"
Transmission Type	5-Spd Disc Drive
Tire Pressure	
Front 11x4.00-4	12 psi
Rear 16x6.5-8	12 psi
Turning Radius	28"
Engine Power (hp)	12.5
Engine Displacement (cc)	344 cc
Engine Oil Capacity	42 - 44 oz.
Fuel Tank Capacity	7 qts.
Spark Plug Gap	.030"
Weight	314 lbs.

Common Service Part	Part Number
Cutter Blade (28" Standard Air-Lift)	7019515
Cutting Deck Belt (28")	7022252
Air Filter Cartridge	698413 or 5079
Air Filter Pre-Cleaner	697292 or 5079
Fuel Stabilizer	5041
Spark Plug	491055

Engine Power Rating Information: The gross power rating for individual gas engine models is labeled in accordance with SAE (Society of Automotive Engineers) code J1940 (Small Engine Power & Torque Rating Procedure), and rating performance has been obtained and corrected in accordance with SAE J1995 (Revision 2002-05). Torque values are derived at 3060 RPM; horsepower values are derived at 3600 RPM. Actual gross engine power will be lower and is affected by, among other things, ambient operating conditions and engine-to-engine variability. Given both the wide array of products on which engines are placed and the variety of environmental issues applicable to operating the equipment, the gas engine will not develop the rated gross power when used in a given piece of power equipment (actual "on-site" or net power). This difference is due to a variety of factors including, but not limited to, accessories (air cleaner, exhaust, charging, cooling, carburetor, fuel pump, etc.), application limitations, ambient operating conditions (temperature, humidity, altitude), and engine-to-engine variability. Due to manufacturing and capacity limitations, Briggs & Stratton may substitute an engine of higher rated power for this Series engine.

Manual del operador



Tractor cortacésped con motor trasero con arranque eléctrico

Modelo N°

107.280340 (Motor Briggs & Stratton de 12,5 HP con plataforma del cortacésped de 71 cm [28 pulg.]

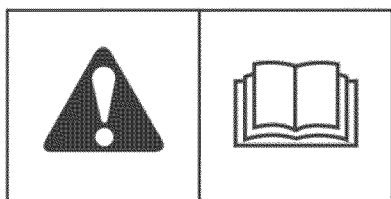

Para obtener respuestas a sus preguntas sobre este producto, llame al:

1-800-659-5917

Línea de ayuda de Sears Craftsman

Lunes a sábado de 5 a.m. a 5 p.m.

Sears, Roebuck and Co., Hoffman Estates, IL 60179 EE.UU.

Visite nuestro sitio Web de Craftsman: www.sears.com/craftsman

7103268
Modificación B

Gracias por comprar este producto fabricado con la calidad Craftsman. Nos complace que haya depositado su confianza en nuestra marca. Cuando se opera y se mantiene según las instrucciones de este manual, su producto Craftsman le puede brindar muchos años de servicio confiable.

Este manual contiene información de seguridad para que tome conciencia de los peligros y riesgos asociados a esta máquina y cómo evitarlos. Esta máquina se diseñó y pensó solamente para obtener un corte de acabado de césped establecido y no fue prevista para otros propósitos. Es importante que lea y comprenda a cabalidad estas instrucciones antes de que intente arrancar u operar este equipo. **Guarde estas instrucciones para consultas futuras.**

NÚMEROS DE IDENTIFICACIÓN

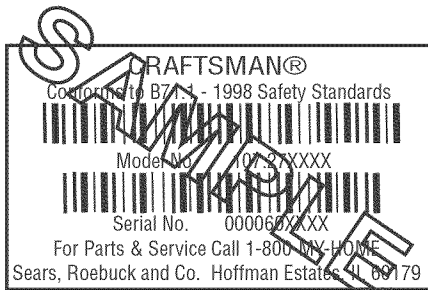

DATOS DE REFERENCIA DEL PRODUCTO

Nombre/número de descripción del modelo	
Número de inventario	Número de serie de la unidad
Fecha de compra	

DATOS DE REFERENCIA DEL MOTOR

Fabricante del motor	Modelo del motor
Tipo/especificaciones del motor	Código/número de serie del motor

Cuando se comunique con el centro de mantenimiento para pedir piezas de repuesto, mantenimiento o información, el usuario DEBE tener estos números a su disposición.

Registre su nombre/número de modelo, los números de identificación del fabricante y los números de serie del motor en el espacio proporcionado para tener un acceso fácil.

La etiqueta de identificación está situada en el lado de abajo del asiento. Incline el asiento hacia delante para acceder a la etiqueta de identificación.

Para obtener respuestas a sus preguntas sobre este producto, llame a la línea de ayuda de Sears Craftsman en el 1-800-659-5917, de lunes a sábado de 5 a.m. a 5 p.m.

ÍNDICE DE CONTENIDOS

Números de identificación	2	Mantenimiento	17
Declaración de garantía	3	Almacenaje	21
Declaración de emisiones	4	Localización de fallas	22
Seguridad del operario	5	Especificaciones técnicas	24
Características y mandos	10	Repuestos	PTS-1
Funcionamiento	11		

GARANTÍA

GARANTÍA COMPLETA DE FABRICACIÓN

Cuando se opera y mantiene de acuerdo con todas las instrucciones que se proporcionan, si alguna pieza no ampliable de este equipo falla debido a un defecto en los materiales o en la fabricación dentro de dos años desde la fecha de compra, llame a 1-800-659-5917 para solicitar una reparación gratuita en su hogar.

La cubierta y el eje delantero se repararán de manera gratuita durante cinco años desde la fecha de compra si se trata de un defecto de material o de fabricación.

La cobertura de la garantía anterior se aplica solo durante 90 días desde la fecha de compra si este equipo se usa alguna vez con propósitos comerciales o de arriendo.

En todos los casos, si la reparación no es posible, el equipo se reemplazará de manera gratuita con el mismo modelo o un modelo equivalente.

La batería se reemplazará de manera gratuita durante 90 días desde la fecha de compra si tiene defectos en los materiales o en la fabricación (o se comprueba que no almacena carga).

Esta garantía SOLAMENTE cubre defectos de material y fabricación. Sears NO pagará:

- Artículos desechables que se gasten durante el uso normal, entre los que se incluyen, entre otros cuchillas, bujías, depuradores de aire, correas y filtros de aceite.
- Servicio de mantenimiento normal, cambios de aceite o afinamientos.
- Reemplazo o reparación de neumáticos debido a pinchazos por objetos exteriores, como clavos, espinas, tocones o vidrios.
- Reemplazo o reparación de neumáticos o ruedas producto de desgaste normal, accidentes o funcionamiento o mantenimiento inadecuados.
- Reparaciones necesarias debido a abuso del operador, incluidos, entre otros, daños provocados por remolcar objetos que sobrepasen la capacidad del equipo con asiento, impactos a objetos que doblen el bastidor o cigüeñal, o sobrepasar la velocidad del motor.
- Reparaciones necesarias debido a negligencia del operador, incluidos, entre otros, daños eléctricos y mecánicos provocados por almacenamiento inadecuado, no utilizar el grado ni la cantidad correcta de aceite de motor, no mantener la cubierta libre de desperdicios inflamables o no mantener al equipo con asiento según las instrucciones que se incluyen en el manual del operador.
- Limpiezas o reparaciones al motor (sistema de combustible) provocadas por combustible que se determine como contaminado u oxidado (deteriorado). En general, se debe utilizar el combustible dentro de 30 días a partir de la fecha de compra.
- Desgaste y deterioro normal de los acabados exteriores o reemplazo de la etiqueta del producto.

Esta garantía sólo se aplica mientras este producto esté dentro de los Estados Unidos.

Esta Garantía le otorga derechos legales específicos, y Ud. puede ostentar otros derechos, que pueden variar de estado en estado.

Sears, Roebuck and Co., Hoffman Estates, IL 60179

Emissions Control System Warranty Statement

Briggs & Stratton Corporation (B&S), the California Air Resource Board (CARB), and the United States Environmental Protection Agency (U.S. EPA) Emissions Control System Warranty Statement (Owner's Defect Warranty Rights and Obligations)

California, United States and Canada Emissions Control Defects Warranty Statement

The California Air Resource Board (CARB), U.S. EPA and B&S are pleased to explain the Emissions Control System Warranty on your small off-road engine (SORE). In California, new small off-road engines model year 2006 and later must be designed, built and equipped to meet the State's stringent anti-smog standards. Elsewhere in the United States, new non-road, spark-ignition engines certified for model year 1997 and later must meet similar standards set forth by the U.S. EPA. B&S must warrant the emissions control system on your engine for the periods of time listed below, provided there has been no abuse, neglect or improper maintenance of your small off-road engine.

Your emissions control system includes parts such as the carburetor, air cleaner, ignition system, fuel line, muffler and catalytic converter. Also included may be connectors and other emissions related assemblies.

Where a warrantable condition exists, B&S will repair your small off-road engine at no cost to you including diagnosis, parts and labor.

Briggs & Stratton Emissions Control Defects Warranty Coverage

Small off-road engines are warranted relative to emissions control parts defects for a period of two years, subject to provisions set forth below. If any covered part on your engine is defective, the part will be repaired or replaced by B&S.

Owner's Warranty Responsibility

As the small off-road engine owner, you are responsible for the performance of the required maintenance listed in your Operating and Maintenance Instructions. B&S recommends that you retain all your receipts covering maintenance on your small off-road engine, but B&S cannot deny warranty solely for the lack of receipts or for your failure to ensure the performance of all scheduled maintenance.

As the small off-road engine owner, you should however be aware that B&S may deny you warranty coverage if your small off-road engine or a part has failed due to abuse, neglect, improper maintenance or unapproved modifications.

You are responsible for presenting your small off-road engine to an Authorized B&S Service Dealer as soon as a problem exists. The undisputed warranty repairs should be completed in a reasonable amount of time, not to exceed 30 days.

If you have any questions regarding your warranty rights and responsibilities, you should contact a B&S Service Representative at (414) 259-5262.

The emissions warranty is a defects warranty. Defects are judged on normal engine performance. The warranty is not related to an in-use emissions test.

Briggs & Stratton Emissions Control Defects Warranty Provisions

The following are specific provisions relative to your Emissions Control Defects Warranty Coverage. It is in addition to the B&S engine warranty for non-regulated engines found in the Operating and Maintenance Instructions.

1. Warranted Parts

Coverage under this warranty extends only to the parts listed below (the emissions control systems parts) to the extent these parts were present on the engine purchased.

- a. Fuel Metering System
 - Cold start enrichment system (soft choke)
 - Carburetor and internal parts
 - Fuel pump
 - Fuel line, fuel line fittings, clamps
 - Fuel tank, cap and tether
 - Carbon canister
- b. Air Induction System
 - Air cleaner
 - Intake manifold
 - Purge and vent line
- c. Ignition System
 - Spark plug(s)
 - Magneto ignition system
- d. Catalyst System
 - Catalytic converter
 - Exhaust manifold
 - Air injection system or pulse valve
- e. Miscellaneous Items Used in Above Systems
 - Vacuum, temperature, position, time sensitive valves and switches
 - Connectors and assemblies

2. Length of Coverage

B&S warrants to the initial owner and each subsequent purchaser that the Warranted Parts shall be free from defects in materials and workmanship which caused the failure of the Warranted parts for a period of two years from the date the engine is delivered to a retail purchaser.

3. No Charge

Repair or replacement of any Warranted Part will be performed at no charge to the owner, including diagnostic labor which leads to the determination that a Warranted Part is defective, if the diagnostic work is performed at an Authorized B&S Service Dealer as listed in the "Yellow Pages" under "Engines, Gasoline," "Gasoline Engines," "Lawn Mowers," or similar category.

4. Claims and Coverage Exclusions

Warranty claims shall be filed in accordance with the provisions of the B&S Engine Warranty Policy. Warranty coverage shall be excluded for failures of Warranted Parts which are not original B&S parts or because of abuse, neglect or improper maintenance as set forth in the B&S Engine Warranty Policy. B&S is not liable to cover failures of Warranted Parts caused by the use of add-on, non-original, or modified parts.

5. Maintenance

Any Warranted Part which is not scheduled for replacement as required maintenance or which is scheduled only for regular inspection to the effect of "repair or replace as necessary" shall be warranted as to defects for the warranty period. Any Warranted Part which is scheduled for replacement as required maintenance shall be warranted as to defects only for the period of time up to the first scheduled replacement for that part. Any replacement part that is equivalent in performance and durability may be used in the performance of any maintenance or repairs. The owner is responsible for the performance of all required maintenance, as defined in the B&S Operating and Maintenance Instructions.

6. Consequential Coverage

Coverage hereunder shall extend to the failure of any engine components caused by the failure of any Warranted Part still under warranty.

Look For Relevant Emissions Durability Period and Air Index Information On Your Engine Emissions Label

Engines that are certified to meet the California Air Resources Board (CARB) Emissions Standard must display information regarding the Emissions Durability period and the Air Index. Briggs & Stratton makes this information available to the consumer on our emissions labels. The engine emissions label will indicate certification information.

The **Emissions Durability Period** describes the number of hours of actual running time for which the engine is certified to be emissions compliant, assuming proper maintenance in accordance with the Operating and Maintenance Instructions. The following categories are used:

Moderate:

Engine is certified to be emissions compliant for 125 hours of actual running time.

Intermediate:

Engine is certified to be emissions compliant for 250 hours of actual running time.

Extended:

Engine is certified to be emissions compliant for 500 hours of actual engine running time. For example, a typical walk-behind lawn mower is used 20 to 25 hours per year. Therefore, the **Emissions Durability Period** of an engine with an **intermediate** rating would equate to 10 to 12 years.

Briggs & Stratton engines are certified to meet the United States Environmental Protection Agency (EPA) Phase 2 emissions standards. For Phase 2 certified engines, the Emissions Compliance Period referred to on the Emissions Compliance label indicates the number of operating hours for which the engine has been shown to meet Federal emissions requirements.

For engines less than 225 cc displacement.

Category C= 125 hours, Category B= 250 hours, Category A= 500 hours

For engines of 225 cc or more displacement.

Category C= 250 hours, Category B= 500 hours, Category A= 1000 hours

SEGURIDAD DEL OPERADOR

Instrucciones importantes de seguridad

GUARDE ESTAS INSTRUCCIONES - Este manual contiene instrucciones importantes que se deben seguir durante el ajuste inicial, la operación y el mantenimiento del equipo.

Símbolos de seguridad y sus significados



⚠ El símbolo de alerta de seguridad indica un posible peligro de lesiones personales. Se usa una palabra (PELIGRO, ADVERTENCIA o PRECAUCIÓN) como señal con el símbolo de alerta para designar un grado o nivel de gravedad del peligro. Se puede usar un símbolo de seguridad para representar el tipo de peligro. Se usa la palabra AVISO como señal para dirigir prácticas no relacionadas con lesiones personales.

⚠ PELIGRO indica un peligro que, si no se evita, producirá la muerte o lesiones graves.

⚠ ADVERTENCIA indica un peligro que, si no se evita, podría producir la muerte o lesiones graves.

⚠ PRECAUCIÓN indica un peligro que, si no se evita, podría producir lesiones menores o moderadas.

⚠ AVISO dirige prácticas no relacionadas con lesiones personales.

⚠ ADVERTENCIA El escape del motor de este producto contiene sustancias químicas que el estado de California sabe que causan cáncer, defectos congénitos u otros daños reproductivos.

⚠ ADVERTENCIA Ciertos componentes en este producto y sus accesorios relacionados contienen sustancias químicas que el estado de California sabe que causan cáncer, defectos congénitos u otros daños reproductivos. Lávese las manos después de la manipulación.

⚠ ADVERTENCIA Los bornes, terminales y accesorios relacionados con la batería contienen plomo y compuestos de plomo, productos químicos que el estado de California sabe que producen cáncer y defectos congénitos u otros daños reproductivos. Lávese las manos después de usarlos.

⚠ ADVERTENCIA El motor encendido libera monóxido de carbono, un gas venenoso, incoloro e inodoro. Respirar monóxido de carbono puede causar dolor de cabeza, fatiga, vértigo, vómitos, confusión, ataques, náuseas, desmayos o incluso la muerte.

- Opere el equipo **SÓLO** en el exterior.
- Evite que el gas del escape entre en áreas cerradas a través de ventanas, puertas, entradas de ventilación u otras aberturas.

ADVERTENCIA: ¡Esta máquina cortacésped es capaz de amputar manos y pies y puede lanzar objetos que pueden causar lesiones y daños! Si no se cumplen las siguientes instrucciones de SEGURIDAD, el operador o los transeúntes podrían sufrir lesiones graves o la muerte. El propietario de la máquina deberá comprender estas instrucciones y permitirá utilizar la máquina únicamente a personas que comprendan estas instrucciones. Todas las personas que hagan funcionar la máquina deberán ser dueñas de sí mental y físicamente y no deberán hallarse bajo la influencia de ningún tipo de sustancias que puedan deteriorar sus capacidades visuales, su destreza o capacidad de juicio.

Protección a la infancia

Pueden ocurrir accidentes graves si el usuario no está atento ante la presencia de niños. Los niños suelen sentirse atraídos por la unidad y por la actividad del cortacésped. Nunca dé por hecho que los niños vayan a permanecer en el último lugar en el que los vio.

1. MANTENGA a los niños fuera del área de corte y bajo la vigilancia atenta de algún adulto responsable.
2. NO PERMITA que niños ni otros se monten en la máquina, en sus accesorios ni en el equipo remolcado (incluso con las cuchillas DESCONECTADAS). Podrían caerse y resultar gravemente heridos.
3. PERMITA únicamente que adultos y adolescentes responsables con capacidad de juicio madura y bajo la supervisión cercana de un adulto utilicen la máquina.
4. NO opere las cuchillas marcha atrás. DETENGA LAS CUCHILLAS. MIRE detrás y debajo de Ud. antes de retroceder y antes de retroceder y mientras lo haga por si hay niños, animales domésticos u otros peligros.
5. PONGA ESPECIAL CUIDADO al acercarse a esquinas cerradas, arbustos, árboles u otros objetos que puedan obstaculizar la visión.

Cómo evitar que vuelque

Las pendientes son un factor de gran pérdida en los casos de pérdida de control y en los accidentes en los que vuelca el cortacésped, que pueden resultar en lesiones graves o incluso la muerte. Todas las pendientes requieren mayor PRECAUCIÓN. Si no puede ir hacia atrás sobre una pendiente con el cortacésped, o no se siente seguro sobre la pendiente, NO corte el césped en la misma. Ponga el mayor cuidado con los recogedores de hierba y otros elementos anexos: afectan al manejo y a la estabilidad de la máquina. Consulte la Guía de trabajo en pendientes que encontrará al final de esta sección.

1. NO opere la máquina en pendientes que excedan los 10 grados, lo que equivale a 1,1 m (3,5 pies) verticalmente por cada 6,1 m (20 pies) horizontalmente.
2. DESCONECTE las cuchillas cuando se desplace cuesta arriba. Utilice una velocidad lenta evitando giros bruscos.
3. NO maneje la máquina hacia delante y hacia atrás en medio de las pendientes. Manéjela hacia arriba y hacia abajo. Practique sobre las pendientes con las cuchillas desconectadas.
4. EVITE arrancar, detenerse, o girar en pendientes. Si la máquina se detiene mientras sube o los neumáticos pierden tracción, DESCONECTE las cuchillas y retroceda lentamente en línea recta hacia abajo.
5. ESTÉ ALERTA ante la presencia de hoyos y otros peligros ocultos. La hierba alta puede ocultar obstáculos. Manténgase lejos de cunetas, deslaves, alcantarillas, cercas y objetos que puedan salir proyectados.

6. MANTENGA UNA DISTANCIA DE SEGURIDAD mínima de 0,9 metros (3 pies) de separación desde el borde de zanjas y otros desniveles. La máquina podría volcar si se mete una parte en un desnivel.
7. Comience siempre a moverse hacia delante lentamente y con precaución.
8. Manipule pesos o un transportador de carga con peso según las instrucciones proporcionadas junto con el recolector de hierba. NO MANEJE la máquina en pendientes que excedan los 10 grados.
9. NO coloque su pie en el suelo para intentar estabilizar la máquina.
10. NO utilice el cortacésped sobre hierba húmeda. La reducción de tracción puede causar deslizamiento.
11. Escoja una velocidad lo suficientemente baja de manera tal que no tenga que detenerse ni hacer cambios en pendientes. Los neumáticos pueden perder tracción en las pendientes incluso cuando los frenos funcionen debidamente.
12. NO maneje la máquina en circunstancias en que la tracción, la dirección o la estabilidad sean dudosas.
13. Siempre mantenga la máquina con un cambio al bajar pendientes. NO utilice el punto muerto (ni libere el hidro-rodamiento) para bajar una pendiente.

Antes de cortar el césped

1. Lea, comprenda y siga las instrucciones y advertencias en este manual y las indicadas sobre la máquina, el motor y sus accesorios. Conozca los controles y el uso apropiado de la máquina antes de comenzar.
2. Únicamente deben hacer funcionar la máquina personas maduras y responsables y sólo después de la adecuada instrucción.
3. Los datos indican que operadores de 60 o más años están implicados en un amplio porcentaje de lesiones relacionadas con el uso de tractores cortacésped. Estos operadores deberán evaluar su capacidad de utilizar la unidad de manera lo suficientemente segura como para protegerse a sí mismos y a los demás frente a graves lesiones.
4. Manipule el combustible con especial precaución. Los combustibles son inflamables y sus vapores, explosivos. Utilice un recipiente de combustible homologado. NO retire la tapa del combustible ni añada combustible con el motor en marcha. Añada combustible únicamente en exteriores y con el motor parado y frío. Limpie el carburante derramado sobre la máquina. NO fume.
5. Practique el manejo de la máquina con LAS CUCHILLAS DESCONECTADAS para aprender los controles y desarrollar destrezas.
6. Revise la zona de césped que se va a cortar y retire objetos como juguetes, cables, piedras, ramas y otros elementos que puedan causar lesiones si

- son lanzados por la cuchilla o interfieren con el funcionamiento del cortacésped.
7. Mantenga personas y animales domésticos lejos de la zona donde va a cortar el césped. **DETENGA** inmediatamente las cuchillas, **DETENGA** el motor y **DETENGA** el cortacésped en caso de que alguna persona entre en la zona.
 8. Compruebe con frecuencia el adecuado funcionamiento y ubicación de protecciones, deflectores, interruptores, controles de la cuchilla y otros dispositivos de seguridad.
 9. Asegúrese de que todas las calcomanías de seguridad sean claramente legibles. Reemplácelas si están dañadas.
 10. Cuando corte el césped, protéjase con gafas de seguridad, mascarilla anti-polvo, pantalones largos y calzados sólidos.
 11. Debe saber cómo **DETENER** rápidamente las cuchillas y el motor para prepararse ante cualquier emergencia.
 12. Extreme la precaución cuando cargue o descargue la máquina en un remolque o camión.
 13. Compruebe con frecuencia los componentes del recogedor de hierba en busca de señales de desgaste o deterioro y reemplácelos, según sea necesario, para evitar las lesiones producidas por el lanzamiento de objetos a través de puntos débiles o desgastados.

Manipulación segura de la gasolina

Para evitar lesiones personales o daños en los bienes, extreme la precaución cuando manipule gasolina. La gasolina es extremadamente inflamable y sus vapores son explosivos.

1. Apague cigarrillos, puros, pipas y cualquier otra fuente que pueda provocar incendios.
2. Utilice sólo un recipiente de combustible homologado.
3. **NO** retire la tapa del combustible ni añada combustible con el motor en marcha. Deje que el motor se enfríe antes de reponer el combustible.
4. **NO** reponga combustible en la máquina en espacios cerrados.
5. **NO** almacene la máquina ni el recipiente de combustible en interiores donde haya llamas expuestas, chispas ni luces pilotos como las de los calentadores de agua u otros dispositivos.
6. **NUNCA** llene recipientes de combustible en el interior de vehículos ni sobre el lecho de un camión o remolque con revestimientos de plástico. Sitúe los recipientes sobre el suelo, lejos del vehículo, antes de llenarlos.
7. Retire del vehículo o camión el equipamiento alimentado por gasolina y reponga el combustible sobre el suelo. Si ello no es posible, reponga el combustible del equipo utilizando un contenedor portátil y no con boquillas dosificadoras de gasolina.
8. **NO** arranque equipos alimentados por gasolina en vehículos o remolques cerrados.
9. Mantenga la boquilla en contacto con el borde de la abertura del depósito o recipiente de combustible en todo momento hasta haber completado el llenado. **NO** use un dispositivo para trabar y abrir boquillas.

10. Si se derrama combustible sobre la ropa, cámbiese la ropa de inmediato.
11. Nunca llene en exceso el depósito de combustible. Vuelva a situar la tapa del combustible y ajústela firmemente.

Consideraciones generales de seguridad de funcionamiento

1. Monte y desmonte la máquina desde el lado izquierdo. Manténgase alejado del agujero de descarga en todo momento.
2. Encienda el motor desde el asiento del operador. Asegúrese de que las cuchillas estén **DESACTIVADAS** y de que esté activado el freno de mano.
3. **NO** abandone la máquina con el motor en funcionamiento. **DETENGA** el motor, **DETENGA** las cuchillas, **ACTIVE** el freno y quite la llave antes de abandonar el puesto del conductor.
4. **NO** maneje la máquina a no ser que esté correctamente sentado con los pies en los apoyos o pedales.
5. **DETENGA LAS CUCHILLAS y EL MOTOR** y asegúrese de que las cuchillas se hayan detenido antes de quitar el recolector de césped o antes de desatascar el cortacésped para evitar la amputación de dedos o manos.
6. Las cuchillas deben estar **DESCONECTADAS** excepto cuando se corte el césped. Coloque las cuchillas en la posición más alta cuando esté cortando sobre una superficie desigual.
7. Mantenga las manos y los pies lejos de las cuchillas en rotación que están debajo de la plataforma. **NO** ponga el pie en el suelo mientras las **CUCHILLAS** estén **ACTIVADAS** o la mientras la máquina esté en movimiento.
8. **NO** maneje la máquina sin que el recolector de césped o los protectores estén correctamente colocados y en funcionamiento. **NO** apunte la descarga hacia personas, coches en tránsito, ventanas o puertas.
9. Reduzca la velocidad antes de realizar giros.
10. Tenga cuidado con el tránsito al cruzar o pasar cerca de vías.
11. **DETENGA** la máquina inmediatamente después de golpear obstáculos. Inspeccione el cortacésped y repare los daños antes de volver a manejarlo.
12. Maneje la máquina sólo durante el día o con luz artificial potente.
13. Mueva **LENTAMENTE** la palanca de mando (si la tiene) para mantener el control durante cambios de velocidad y de sentido.
14. **NO** haga funcionar el motor en zonas cerradas. Los gases del tubo de escape del motor contienen monóxido de carbono, un veneno letal.
15. **NO** descargue materiales contra paredes ni obstáculos. Los materiales pueden rebotar hacia el operador.
16. Utilice únicamente accesorios aprobados por el fabricante. Consulte las instrucciones del fabricante para obtener información sobre el funcionamiento y la instalación de accesorios.

Remolcar

1. Remolque solamente con una máquina que tenga un enganche diseñado para remolque. NO sujete el equipo remolcado a un lugar que no sea el punto de enganche.
2. Siga las recomendaciones del fabricante respecto a los límites de peso para equipos remolcados y remolque en pendientes.
3. NO permita que niños ni otras personas se suban al equipo remolcado.
4. En pendientes, el peso del equipo remolcado puede causar pérdida de tracción y pérdida de control.
5. Desplácese lentamente y deje una distancia extra para poder detenerse.
6. Tenga CUIDADO cuando arrastre cargas. No lleve más carga de la que pueda controlar con seguridad y sujete las cargas a la placa de enganche según se especifica en las instrucciones de los accesorios.
7. Únicamente realice reparaciones y ajustes en el motor cuando éste se encuentre detenido. Retire el (los) cable (s) de bujía del enchufe de la bujía y fije el (los) cable (s) lejos del (los) enchufe (s) de la bujía.
8. NO cambie los ajustes de velocidad del regulador del motor ni acelere en exceso el motor.
9. Las cuchillas del cortacésped son afiladas y pueden producir cortes. Envuelva las cuchillas o utilice gruesos guantes de cuero y extreme la PRECAUCIÓN cuando las manipule.
10. NO pruebe la existencia de chispas conectando la bujía a tierra junto al orificio de la bujía; la bujía podría encender la gasolina que sale del motor.
11. Mantenga o reemplace las etiquetas de seguridad e instrucciones, según sea necesario.

Seguridad de mantenimiento

1. NO guarde el cortacésped ni el recipiente para el combustible en lugares donde los vapores puedan alcanzar una llama abierta, chispa o luz piloto como la de los calentadores de agua, hornos, secadoras de ropa u otros dispositivos que utilicen gas. Permita que el motor se enfríe antes de almacenar la máquina en un lugar cerrado. Guarde el contenedor o recipiente para el carburante fuera del alcance de los niños en un lugar deshabitado.
2. Mantenga la máquina libre de césped, hojas o exceso de grasa para reducir el riesgo de incendio y sobrecalentamiento del motor.
3. Cuando drene el depósito de combustible, drene el combustible en el exterior hasta un recipiente homologado y lejos de llamas expuestas.
4. Siempre procure una ventilación adecuada cuando el motor esté en funcionamiento. Los gases del tubo de escape del motor contienen monóxido de carbono, un veneno inodoro letal.
5. Desconecte el cable negativo (negro) de la batería antes de realizar el mantenimiento o cualquier reparación en la máquina. El motor de arranque puede causar lesiones.
6. NO trabaje debajo de la máquina sin bloques de seguridad.

GUÍA SUGERIDA PARA EL AVISTAMIENTO DE PENDIENTES PARA UNA OPERACIÓN SEGURA DEL MONTABLE CON ACCESORIO

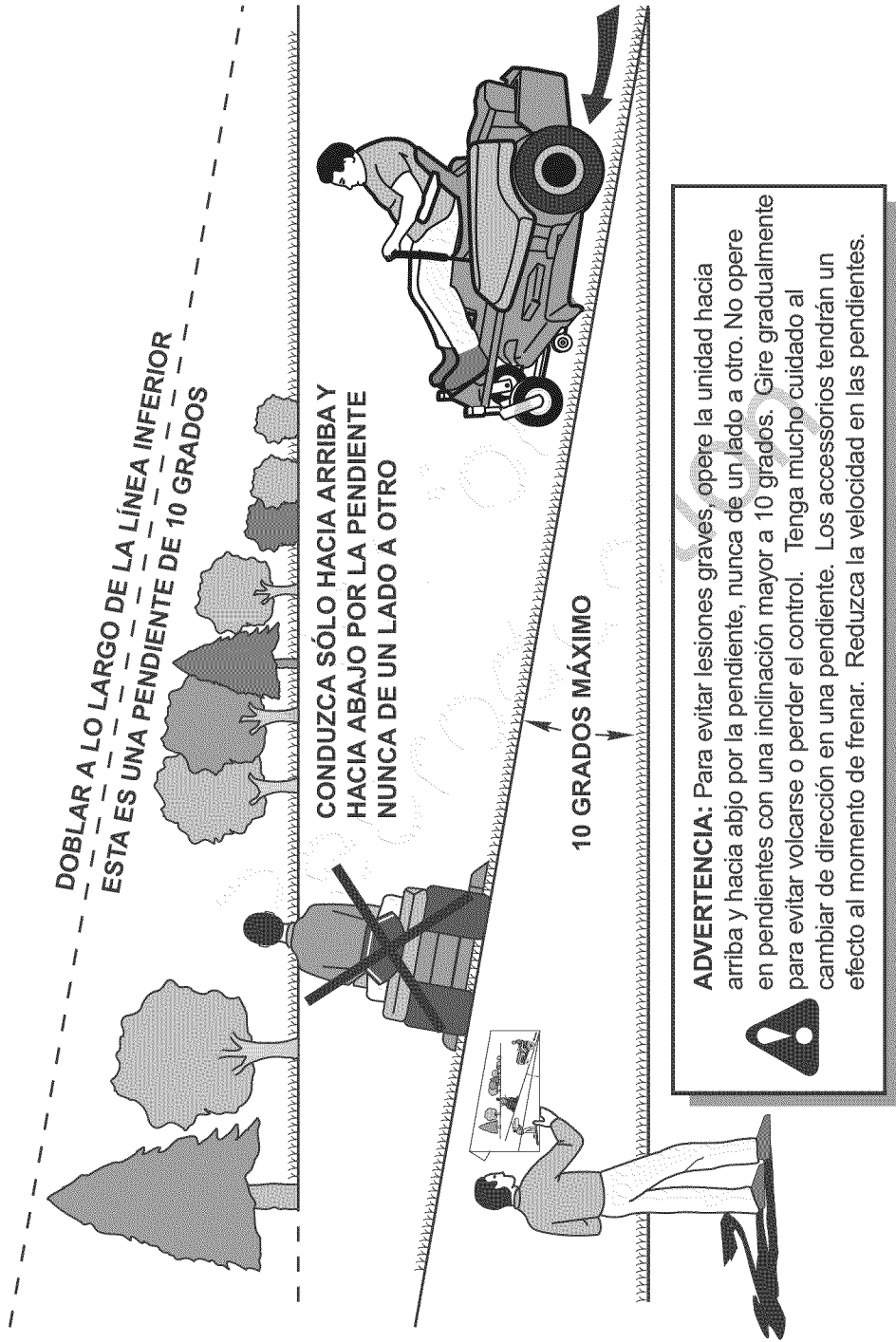

1. Doble la página a lo largo de la línea punteada como se indica arriba.
2. Sostenga la página frente a usted de modo que el borde izquierdo esté verticalmente paralelo al tronco de un árbol u otra estructura vertical.
3. Mire por encima del doblez en dirección de la pendiente que desea medir.
4. Compare el ángulo del doblez con la pendiente de la colina.

CARACTERÍSTICAS Y CONTROLES

AVISO: Las figuras e ilustraciones en este manual se proporcionan sólo como referencia y pueden diferir de su modelo específico.

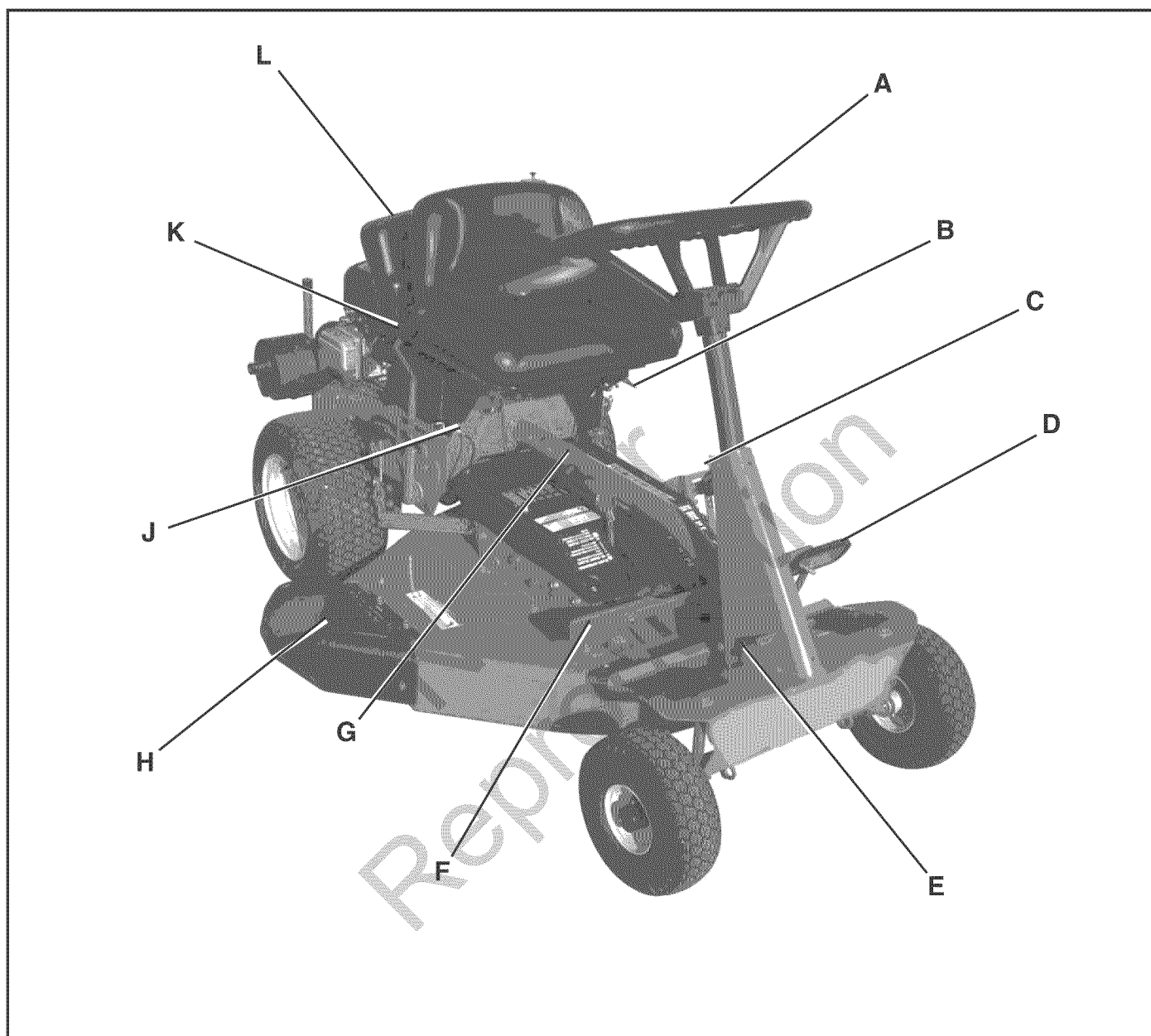

- | | |
|---|---|
| A. Volante | G. Palanca de la cuchilla |
| B. Control de velocidad del motor (no se muestra) | H. Deflector de descarga |
| C. Interruptor de encendido | J. Control de desenganche |
| D. Pedal del embrague/freno | K. Palanca de cambios de la transmisión |
| E. Enganche del freno de estacionamiento | L. Depósito de combustible |
| F. Pedal del freno | |

OPERACIÓN

Recomendaciones de aceite

Se recomienda el uso de aceites certificados con la garantía de Briggs & Stratton para un rendimiento óptimo. Se pueden aceptar otros aceites detergentes de alta calidad si están clasificados para el servicio SF, SG, SH, SJ o superior. No utilice aditivos especiales.

Las temperaturas exteriores determinan la viscosidad adecuada del aceite para el motor. Use la tabla para seleccionar la viscosidad óptima para la variación estimada de temperatura exterior.

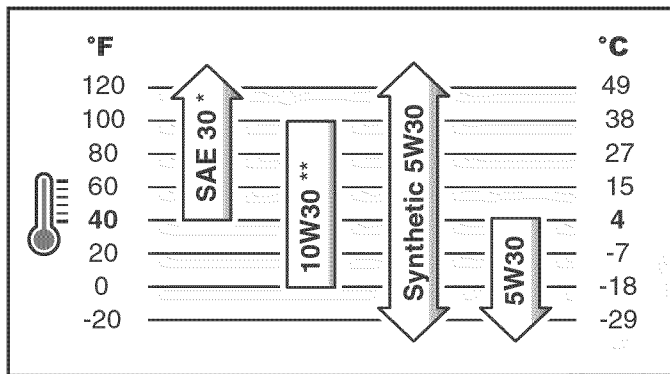

Cómo revisar/agregar aceite

1. Retire la varilla de nivel de aceite y límpiela con un paño limpio.
2. Inserte y apriete la varilla de nivel de aceite.
3. Retire la varilla de nivel de aceite y revise el nivel de éste. Debe estar en la parte superior del indicador lleno en la varilla de nivel de aceite.
4. Si estuviera bajo, agregue aceite lentamente en el llenado de aceite de motor. **No llene en exceso.** Después de agregar aceite, espere un minuto y luego vuelva a revisar el nivel de aceite.
5. Vuelva a poner y apriete la varilla de nivel de aceite.

Presión de aceite

Si la presión de aceite fuera demasiado baja, un presostato (si lo tiene) detendrá el motor o activará un dispositivo de advertencia en el equipo. Si sucede esto, detenga el motor y revise el nivel de aceite con la varilla de nivel de aceite.

Si el nivel de aceite está debajo de la marca ADD (AÑADIR), agregue aceite hasta que llegue a la

marca FULL (LLENO). Encienda el motor y revise que la presión sea adecuada antes de seguir operando. Si el nivel de aceite está entre las marcas ADD (AÑADIR) y FULL (LLENO), **no encienda** el motor. Comuníquese con un concesionario de servicio de Craftsman para corregir el problema de la presión de aceite.

Recomendaciones sobre combustible

El combustible debe cumplir estos requisitos:

- Gasolina limpia, nueva y sin plomo
- Un mínimo de 87 octanos/87 AKI (91 RON). Para uso en altitudes elevadas, consulte a continuación.
- Se puede aceptar gasolina que contenga hasta un 10% de etanol (gasohol) o hasta un 15% de metil terc-butil éter (MTBE por su sigla en inglés).

PRECAUCIÓN: No utilice gasolinas no homologadas, como es el caso de E85. No haga mezclas con la gasolina ni realice modificaciones en el motor para hacerlo funcionar con otros combustibles. Hacer esto dañará los componentes del motor y **anulará la garantía del motor.** Para proteger el sistema de combustible de la formación de resina, mezcle un estabilizador de combustible con el combustible. Consulte almacenamiento. Todos los combustibles no son iguales. Si ocurren problemas de arranque o de rendimiento, cambie el proveedor de combustible o cambie la marca. El funcionamiento de este motor con gasolina está certificado. El sistema de control de emisiones para el motor corresponde a modificaciones del motor (EM por su sigla en inglés).

Altitud elevada

En altitudes superiores a 1524 metros (5.000 pies), se puede aceptar gasolina de un mínimo de 85 octanos/85 AKI (89 RON). Para seguir cumpliendo con las emisiones, se necesita un ajuste para altitudes elevadas. El funcionamiento sin este ajuste causará menor rendimiento, mayor consumo de combustible y aumento de emisiones. Consulte un concesionario de servicio de Craftsman para obtener información sobre el ajuste para altitudes elevadas.

Se recomienda el funcionamiento del motor en altitudes inferiores a 762 metros (2.500 pies) con el equipo para altitudes elevadas.

Cómo agregar combustible

- ⚠ ADVERTENCIA** La gasolina y sus vapores son extremadamente inflamables y explosivos.
El fuego o las explosiones pueden causar quemaduras graves o incluso la muerte.

Cuando cargue combustible

- Apague el motor y deje que se enfríe al menos durante 2 minutos antes de quitar la tapa del combustible.
- Llene el depósito de combustible en exteriores en un área bien ventilada.
- No llene el depósito de combustible en exceso. Para permitir la expansión de la gasolina, no llene sobre la parte inferior del cuello del depósito de combustible.
- Mantenga la gasolina lejos de chispas, llamas expuestas o de encendido, calor y otras fuentes de encendido.
- Revise frecuentemente las tuberías, el depósito, la tapa y los accesorios de combustible para saber si existen grietas o filtraciones. Reemplácelas, si fuera necesario.
- Si se derrama combustible, espere hasta que se evapore antes de arrancar el motor.

1. Agregue combustible al depósito de combustible después de haber empujado la máquina hacia el exterior donde se puedan disipar los vapores. Asegúrese de que la tapa de llenado de combustible (A, Figura 1) esté ajustada y de que la ventilación (B) esté abierta después de volver a cargar combustible. Si la ventilación está cerrada, el motor se detendrá.



FIGURA 1

Antes del arranque

1. Revise la presión de los neumáticos; agregue o libere aire, según sea necesario, para alcanzar una presión de 6,9 kPa (12 PSI) en la parte delantera y 6,9 kPa (12 PSI) en la parte trasera.
2. Revise las protecciones, deflectores y cubiertas para asegurarse de que todas estén en su lugar y firmemente ajustadas.
3. Revise el aceite de motor y agregue aceite, según sea necesario, hasta que el nivel llegue a la marca FULL (LLENO) (A, Figura 2).

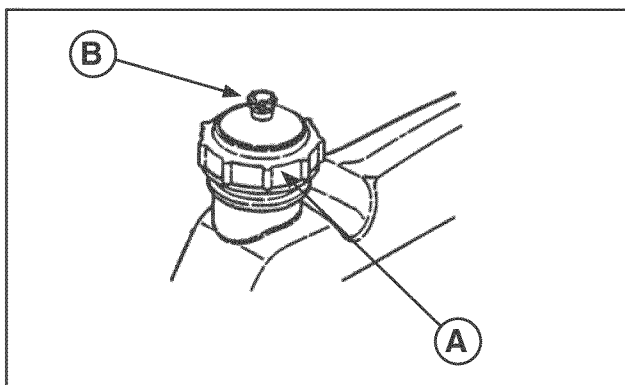

FIGURA 2

4. Con el motor detenido, suelte los dos pernos de ajuste (D, Figura 3) y mueva el asiento hacia la posición deseada. Después del ajuste, apriete los pernos firmemente.
5. Revise el mecanismo de la palanca de la cuchilla. Si se presiona el pedal del freno, se puede mover manualmente la palanca de la cuchilla desde la posición ON (encendido) a OFF (apagado) para detener la cuchilla.
6. Revise el mecanismo de bloqueo de marcha atrás. La palanca de cambios de la transmisión no debe cambiar marcha atrás con el pedal de la cuchilla presionado.





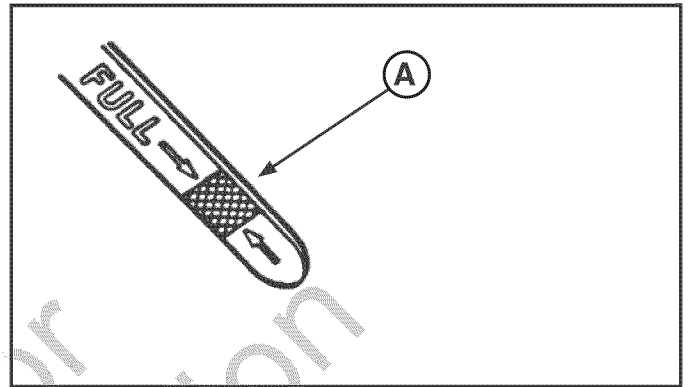

FIGURA 3

Arranque del motor

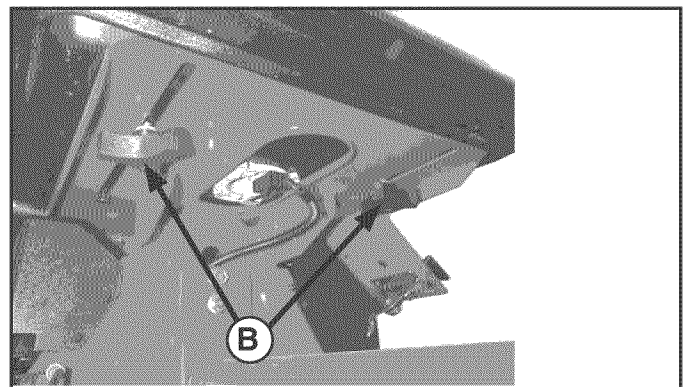
- ⚠ ADVERTENCIA** La gasolina y sus vapores son extremadamente inflamables y explosivos.
-  El fuego o las explosiones pueden causar quemaduras graves o incluso la muerte.
- 

Cuando arranque el motor

- Asegúrese de que la bujía, el silenciador, la tapa del depósito de combustible y el purificador de aire (si lo tiene) se encuentren en su lugar y estén fijos.
- No encienda el motor sin la bujía.
- Si se ahoga el motor, ajuste el estrangulador (si lo tiene) en la posición ABIERTO/MARCHA, mueva el control de la mariposa (si la tiene) a la posición RÁPIDO y arranque el motor hasta que encienda.

- ⚠ ADVERTENCIA** El motor encendido libera monóxido de carbono, un gas venenoso, incoloro e inodoro.
-  Respirar monóxido de carbono puede causar dolor de cabeza, fatiga, vértigo, vómitos, confusión, ataques, náuseas, desmayos o incluso la muerte.
- Opere el equipo SÓLO en el exterior.
 - Evite que el gas del escape entre en áreas cerradas a través de ventanas, puertas, entradas de ventilación u otras aberturas.

- ⚠ ADVERTENCIA** NO arranque el motor con la palanca de cambios de la transmisión en una posición de marcha. Siga cuidadosamente las instrucciones de arranque.

IMPORTANTE: Cuando la llave de encendido se gire hasta la posición de INICIO, el motor se activará, pero no arrancará a menos que el pedal del embrague/freno esté presionado totalmente hasta el fondo y la palanca de la cuchilla esté en la posición desacoplada (OFF). El usuario debe estar en el asiento.

1. Mueva la palanca de cambios de transmisión (A, Figura 4) hasta la posición de punto muerto (N).
2. Cerciórese de que la palanca de la cuchilla (A, Figura 5) esté en la posición desacoplada (OFF).
3. Presione el pedal de embrague/freno (Figura 6) completamente hasta el fondo y manténgalo presionado mientras arranca el motor.



FIGURA 4



FIGURA 5

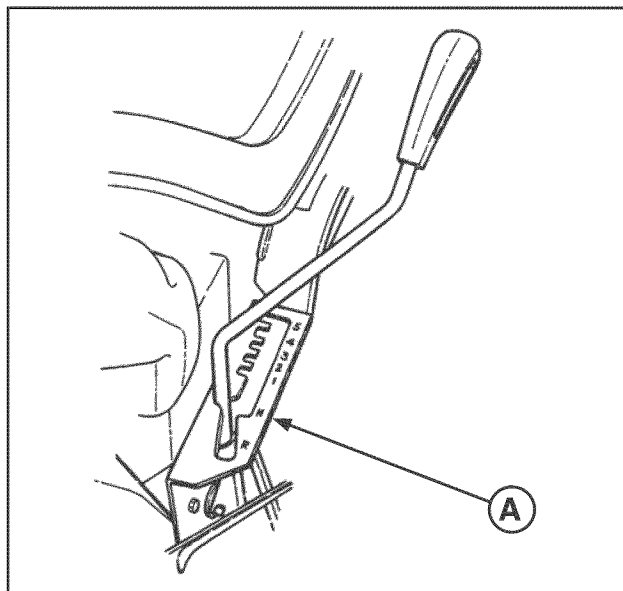

FIGURA 6

- Mueva el control de velocidad del motor (Figura 7) hasta la posición de ESTRANGULACIÓN para arrancar un motor que esté frío.
- Gire la llave de encendido (Figura 8) a la posición de ENCENDIDO hasta que arranque el motor.

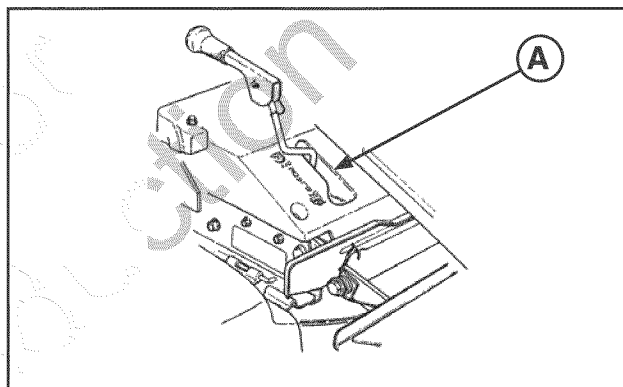
NOTA: Si después de 5 segundos de intentar el arranque, el motor no arranca, suelte la llave, asegúrese de que el pedal del embrague/freno esté totalmente presionado e intente el arranque de nuevo después de esperar aproximadamente 20 segundos.

- Después de que arranque el motor, mueva el control de velocidad del motor hasta la posición RÁPIDO y espere un poco de tiempo a que el motor se caliente y funcione de un modo suave.

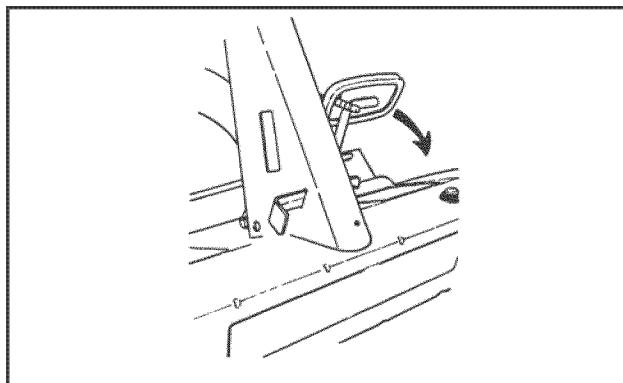

FIGURA 7



FIGURA 8

⚠ ADVERTENCIA NO abandone la máquina con el motor en funcionamiento. **DETENGA** la cuchilla. **DETENGA** el motor. Cambie a neutro y enganche el freno de estacionamiento. Retire la llave.

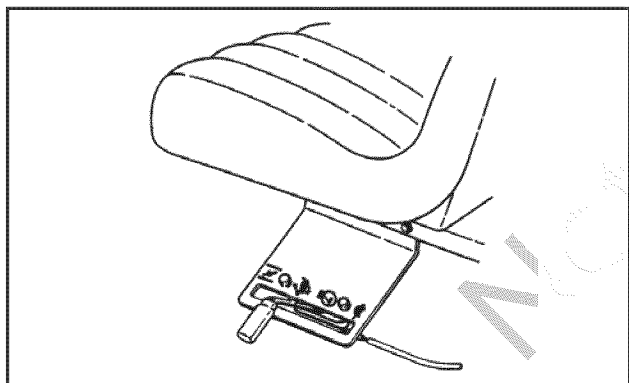
- Coloque la llave de encendido (Figura 8) en la posición de APAGADO para detener el motor.

Cómo operar la cuchilla del cortacésped

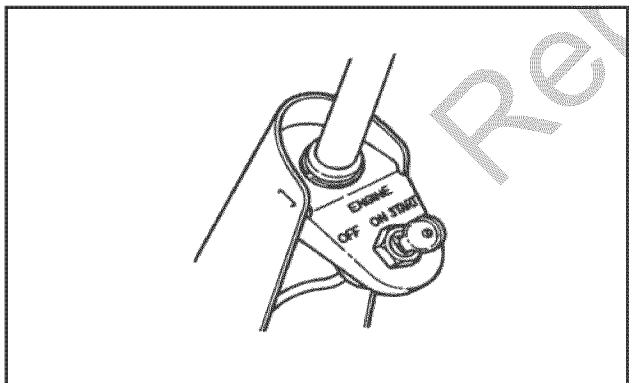
- Para enganchar la cuchilla, mueva la palanca de la cuchilla (A, Figura 9) a la posición de ENCENDIDO, luego presione el pedal de la cuchilla (B) para mantener la palanca de la cuchilla en la posición de ENCENDIDO.
- Para detener la cuchilla, suelte el pedal de la cuchilla. La palanca de la cuchilla volverá a la posición APAGADO.



FIGURA 9

⚠ ADVERTENCIA Si la cuchilla no se detiene completamente dentro de 3 segundos o menos, se debe ajustar el freno de la cuchilla. **NO** opere la máquina hasta que el concesionario de servicio autorizado haya realizado el ajuste apropiado.

Cómo ajustar la altura de corte

- Ajuste la altura de corte subiendo o bajando la palanca elevadora de la plataforma (A, Figura 10) hasta la altura deseada de la muesca de corte (B).
- Cuando haya terminado de cortar el césped, ajuste la palanca elevadora de la plataforma en la posición de máxima altura, luego detenga la cuchilla.

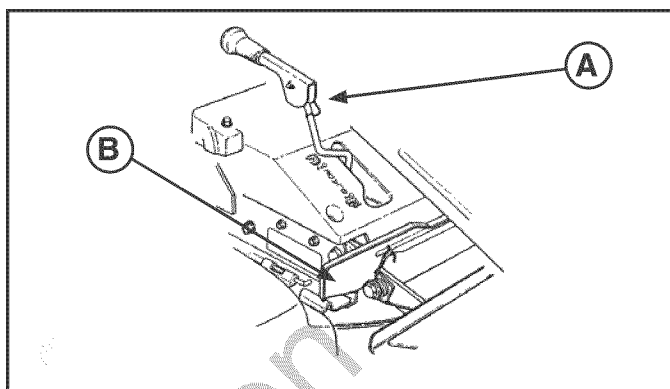

FIGURA 10

Cómo enganchar el sistema de transmisión

⚠ ADVERTENCIA NO opere las cuchillas marcha atrás. **DETENGA LAS CUCHILLAS.** MIRE detrás y debajo de Ud. antes de retroceder y antes de retroceder y mientras lo haga por si hay niños, animales domésticos u otros peligros.

1. Presione completamente el pedal de embrague/freno (**A**, Figura 11).
2. Ponga la palanca de cambios de la transmisión (**A**, Figura 12) en la primera muesca de velocidad hacia delante (**B**).

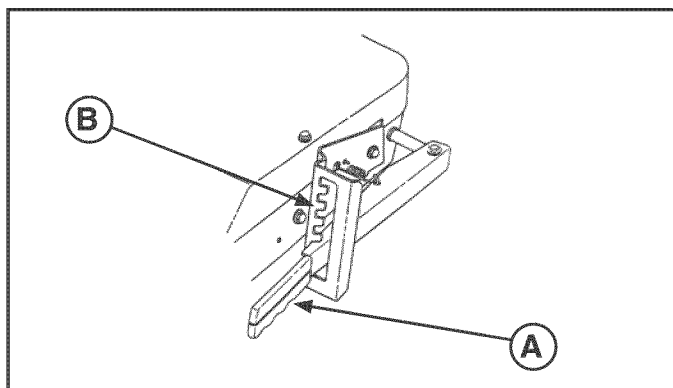

FIGURA 11



FIGURA 12

3. Suavemente suelte el pedal de embrague/freno para comenzar el movimiento hacia delante.
4. Durante el movimiento hacia delante, la palanca de cambios de la transmisión se puede poner en cualquier velocidad deseada hacia delante sin presionar el pedal de embrague/freno.
5. Para detener la máquina, presione completamente el pedal de embrague/freno.

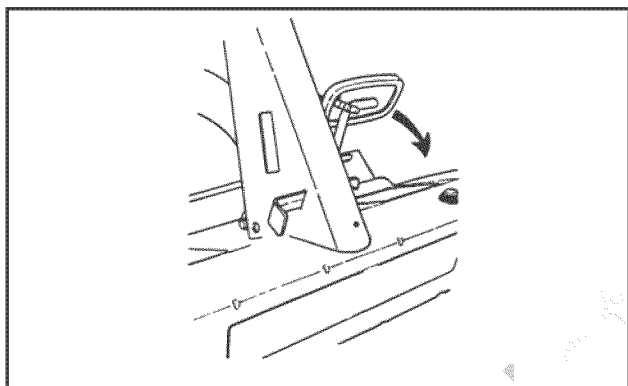
NOTA: Para obtener resultados óptimos de corte, use una velocidad de avance hacia delante más lenta con la mariposa del motor en la posición **RÁPIDO**. Esta combinación permitirá que la cuchilla del cortacésped levante el césped mientras corta suave y uniformemente.

Mecanismo de bloqueo de marcha atrás

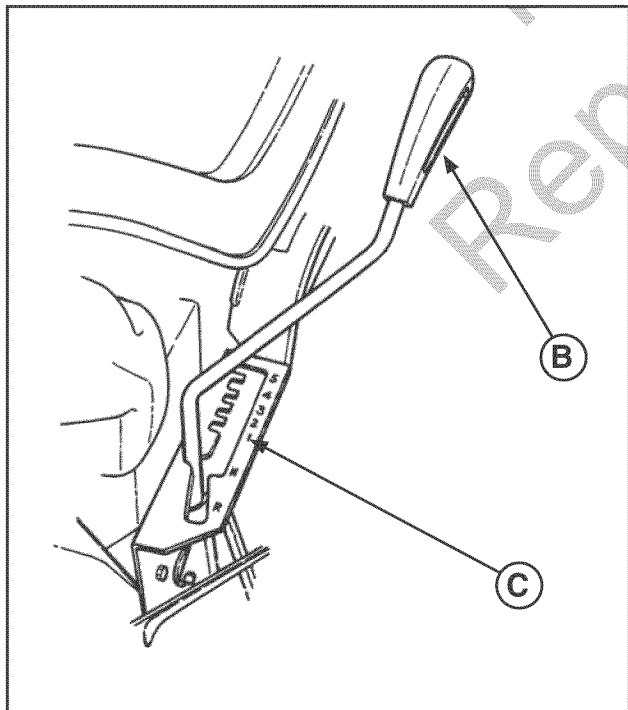
Este tractor cortacésped tiene un mecanismo de bloqueo de marcha atrás. Este dispositivo evita que el cortacésped se cambie marcha atrás mientras la cuchilla esté girando.

1. Para cambiar marcha atrás, detenga la cuchilla soltando el pedal de la cuchilla.
2. Presione completamente el pedal de embrague/freno, luego cambie marcha atrás.
3. Después de haber despejado visualmente el área detrás de la máquina, suavemente suelte el pedal de embrague/freno.

⚠ ADVERTENCIA NO opere las cuchillas marcha atrás. **DETENGA LAS CUCHILLAS.** MIRE detrás y debajo de Ud. antes de retroceder y antes de retroceder y mientras lo haga por si hay niños, animales domésticos u otros peligros.

Desenganche de bloqueo de marcha atrás

ADVERTENCIA PELIGRO DE AMPUTACIÓN



El no respetar estas normas podría resultar en pérdida del control de la unidad, lesiones personales graves o muerte para el usuario o para terceros, o daños en propiedades o en el equipo.



- No corte el césped cuando niños u otras personas estén alrededor.
- No transporte pasajeros (especialmente niños) incluso con las cuchillas desconectadas. Se pueden caer o volver por otro paseo cuando no lo espere.
- Mire hacia abajo y hacia atrás antes y durante el retroceso.

Nunca se debe seleccionar este desenganche, a menos que esté absolutamente seguro de que no haya niños ni otras personas en el área de corte de césped.

Si se usa la máquina en áreas que sea necesario hacer cambios rápidos marcha atrás (como el funcionamiento cerca de alguna vía), la palanca de desenganche permitirá cortar el césped marcha atrás hasta que se suelte el pedal de la cuchilla.

1. Detenga la máquina y la cuchilla.
2. Presione hacia abajo y mantenga presionada la palanca de desenganche en el soporte de cambios de la transmisión.
3. Presione y mantenga presionado el pedal de la cuchilla, luego suelte la palanca de desenganche.
4. Mueva la palanca a la posición de ENCENDIDO.
5. Enganche el sistema de transmisión como se hace normalmente.

Cuando se suelta el pedal de la cuchilla, el mecanismo de bloqueo de marcha atrás se vuelve a activar automáticamente.

IMPORTANTE: NO use el desenganche de bloqueo de marcha atrás como el modo normal de funcionamiento. Revise con frecuencia el funcionamiento adecuado del mecanismo de bloqueo de marcha atrás. La palanca de cambios de la transmisión **no** debe cambiar marcha atrás con el pedal de la cuchilla presionado. NO maneje la máquina si el mecanismo de bloqueo de marcha atrás no está funcionando en forma adecuada. Comuníquese con algún concesionario de servicio de Craftsman para obtener asistencia.

Cómo accionar el freno de mano

1. Para aplicar el freno de estacionamiento, presione el pedal de embrague/freno (**A**, Figura 13) todo el recorrido hacia abajo, deslice el enganche del freno de estacionamiento (**B**) todo el recorrido hacia dentro y suelte el pedal de embrague/freno. Un seguro en el enganche del freno de estacionamiento mantendrá el freno de estacionamiento enganchado.

ADVERTENCIA NO estacione en pendientes.



FIGURA 13



2. Para liberar el freno de estacionamiento, presione firmemente el pedal de embrague/freno. El enganche del freno de estacionamiento se desenganchará automáticamente.

MANTENIMIENTO

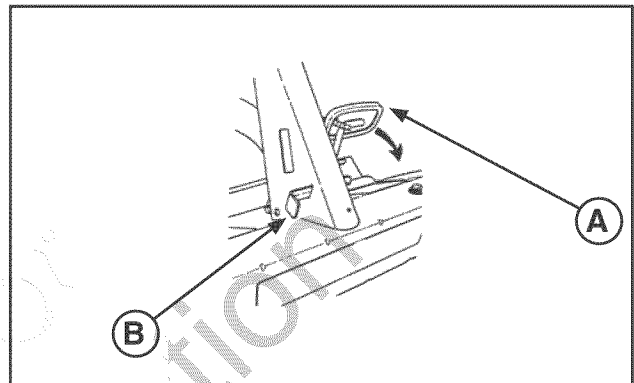
Control de emisiones

Cualquier establecimiento de reparación de motores que no esté en el camino o cualquier individuo pueden realizar el mantenimiento, reemplazo o reparación de los dispositivos y sistemas de control de emisiones. Sin embargo, para conseguir un servicio de control de emisiones “sin costo”, el trabajo debe realizarlo un empleado de Craftsman o un distribuidor de servicio técnico de Briggs & Stratton. Consulte la Garantía de emisiones.

ADVERTENCIA

-  Las chispas involuntarias pueden provocar fuego o descargas eléctricas.
-  El arranque no intencional pueden resultar en enmarañamiento, amputación traumática o laceración.
-  Peligro de incendio.

Antes de realizar ajustes o reparaciones:

- Desconecte el cable de la bujía y manténgalo lejos de ella.
- Desconecte la batería en el terminal negativo (solamente motores con encendido eléctrico).
- Use solamente las herramientas correctas.
- No altere el resorte, las conexiones u otras piezas del regulador para aumentar la velocidad del motor.
- Los repuestos deben ser los mismos y se deben instalar en la misma posición de las piezas originales.
- DETENGA el motor
- DETENGA la cuchilla
- Enganche el freno de estacionamiento
- Retire la llave
- Evite quemaduras graves. Deje que todas las piezas se enfríen antes de trabajar en la máquina.
- La tapa de llenado de combustible y de la ventilación deben estar cerradas firmemente para evitar el derrame de combustible.

Tabla de mantenimiento del equipo

TRACTOR Y CORTACÉSPED
Cada 8 horas o diariamente
Revise el sistema de interbloqueo de seguridad
Limpie los desechos del tractor y de la plataforma del cortacésped
Limpie los desechos del compartimiento del motor
Cada 25 horas o anualmente *
Revise la presión de los neumáticos
Revise el tiempo de detención de las cuchillas del cortacésped
Revise las piezas metálicas sueltas en el tractor y en el cortacésped
Cada 50 horas o anualmente *
Limpie la batería y los cables
Revise los frenos del tractor
Consulte al concesionario anualmente para
Lubrique el tractor y el cortacésped
Revise las cuchillas del cortacésped **

* Lo que suceda primero

** Revise las cuchillas más a menudo en regiones con condiciones de suelos arenosos o con mucha cantidad de polvo.

Tabla de mantenimiento del motor

MOTOR
Primeras 5 horas
Cambie el aceite del motor
Cada 8 horas o diariamente
Revise el nivel de aceite del motor
Cada 25 horas o anualmente *
Limpie el filtro y el predepurador de aire del motor **
Cada 50 horas o anualmente *
Cambie el aceite del motor
Reemplace el filtro de aceite
Anualmente
Reemplace el filtro de aire
Cambie el predepurador de aire
Consulte al concesionario anualmente para
Inspeccione el silenciador y el amortiguador de chispas
Cambie la bujía
Reemplace el filtro de combustible
Limpie el sistema de refrigeración con aire del motor

* Lo que suceda primero

** Limpie más a menudo en condiciones polvorientas o cuando haya desechos transportados por el aire.

Verificación del sistema de bloqueo de seguridad

Esta unidad está equipada con los conmutadores de interbloqueo de seguridad. No intente puentear conmutadores de seguridad y no fuerce nunca dispositivos de seguridad.

Verificaciones de SEGURIDAD operativa

Prueba 1 — El motor NO debe arrancar cuando:

- La palanca de la cuchilla del cortacésped esté en posición de ENCENDIDO o
- La transmisión esté en las posiciones hacia delante o marcha atrás o
- Se suelte el pedal de embrague/freno.

Prueba 2 — El motor DEBE arrancar cuando:

- La cuchilla del cortacésped esté en posición APAGADA y
- La transmisión esté en posición neutra (N) y
- El pedal del embrague esté presionado completamente.

Prueba 3 — El motor debe APAGARSE cuando:

- El operador se levante del asiento con la cuchilla del cortacésped en la posición de ENCENDIDO
- El operador se levante del asiento con la transmisión enganchada
- El operador se levante del asiento con el freno de estacionamiento DESENGANCHADO.

Prueba 4 — Verificación del tiempo de detención de las cuchillas del cortacésped

La cuchilla del cortacésped debe detenerse completamente dentro de tres segundos después de que se APAGUE la cuchilla del cortacésped.

 **ADVERTENCIA** Si la cuchilla no se detiene completamente dentro de 3 segundos o menos, se debe ajustar el freno de la cuchilla. NO opere la máquina hasta que el concesionario de servicio autorizado haya realizado el ajuste apropiado.

Revise el mecanismo de bloqueo de marcha atrás

 **ADVERTENCIA** Si el mecanismo de bloqueo de marcha atrás no está funcionando adecuadamente, NO opere la máquina hasta que el concesionario de servicio autorizado haya realizado el ajuste apropiado.

Revise el funcionamiento del mecanismo de bloqueo de marcha atrás con el motor APAGADO.

1. Presione y mantenga presionados los pedales de la cuchilla.
2. Presione y mantenga presionado el pedal de embrague/freno.
3. La palanca de cambios de la transmisión **no** debe cambiar marcha atrás.

Limpie los desechos del tractor, la plataforma del cortacésped y el compartimiento del motor

 **ADVERTENCIA** Desechos combustibles, tales como hojas, césped, maleza, etc., pueden incendiarse.

- Retire los desechos acumulados en el área del silenciador, de la plataforma del cortacésped y del compartimiento del motor.

Retire el césped cortado, suciedad, hojas u otros desechos de la unidad y del compartimiento del motor.

1. Detenga el motor y déjelo enfriar.
2. Retire la llave de encendido, luego desconecte el cable de la bujía desde la bujía.
3. Use anteojos de seguridad. Con un cepillo o aire comprimido, limpie los desechos de todas las superficies del tractor y de la parte superior de la plataforma del cortacésped.
4. Limpie completamente el compartimiento del motor, incluyendo los desechos de la rejilla de entrada de la parte superior del motor (A, Figura 15), aletas expuestas de refrigeración del motor y alrededor del conjunto del filtro de aire.

Verificación de la presión de los neumáticos

La presión de los neumáticos se debe revisar (Figura 14) en forma periódica y mantenerse según la presión que aparece en la página de especificaciones.

NOTA: Estas presiones pueden diferir ligeramente del inflado máximo "Max Inflation" (inflado máximo) que consta impreso en la superficie lateral de los neumáticos.



FIGURA 14

Verificación del tiempo de detención de las cuchillas del cortacésped

⚠ ADVERTENCIA Si la cuchilla no se detiene completamente dentro de 3 segundos o menos, se debe ajustar el freno de la cuchilla. NO opere la máquina hasta que el concesionario de servicio autorizado haya realizado el ajuste apropiado.

1. Revise que el freno de la cuchilla funcione adecuadamente. La cuchilla debe dejar de girar dentro de 3 segundos o menos después de mover la palanca de control de la cuchilla a la posición APAGADO o después de soltar los pedales de la cuchilla.

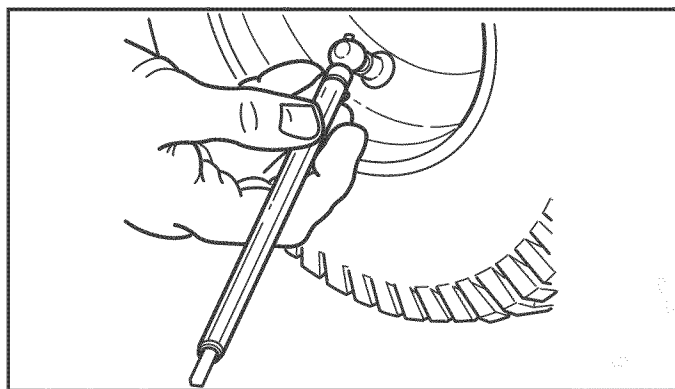
Limpie la batería y los cables

⚠ ADVERTENCIA Los bornes, terminales y accesorios relacionados con la batería contienen plomo y compuestos de plomo, productos químicos que el estado de California sabe que producen cáncer y defectos congénitos u otros daños reproductivos. Lávese las manos después de usarlos.

1. Desconecte los cables de la batería, primero el negativo (**B**, Figura 15).
2. Retire la banda elástica que sujeta la batería y luego saque la batería.
3. Limpie la batería, los terminales de la batería y el compartimiento de la batería con una solución de bicarbonato de sodio y agua.
4. Enjuague con agua limpia.
5. Vuelva a instalar la batería y asegúrela con la banda elástica.
6. Vuelva a conectar los cables de la batería. Primero conecte el cable positivo (**A**), luego conecte el cable negativo (**B**).
7. Cubra los extremos del cable y los terminales de la batería con vaselina o grasa aislante.



FIGURA 15

Verificación de los frenos del tractor

1. Revise que el freno de la máquina funcione adecuadamente. Enganche el freno de estacionamiento y empuje la máquina. Los neumáticos traseros deben deslizarse. Conduzca la máquina hacia delante y aplique el freno. La máquina debe detenerse completamente en menos de 1,5 metros (5 pies).

⚠ ADVERTENCIA Si la cuchilla no se detiene completamente dentro de 3 segundos o menos, se debe ajustar el freno de la cuchilla. NO opere la máquina hasta que el concesionario de servicio autorizado haya realizado el ajuste apropiado.

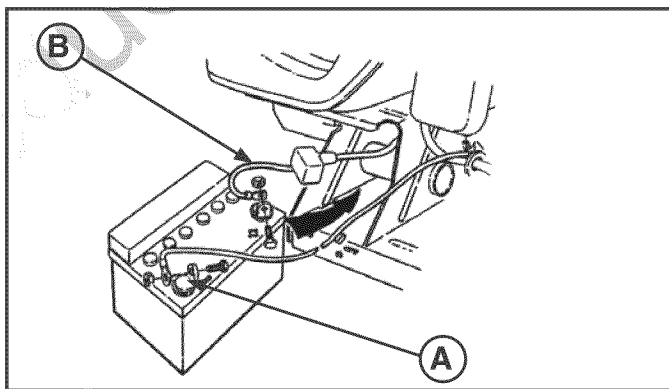
Cómo cambiar el aceite del motor

Compruebe los frenos para asegurarse de que funcionan correctamente. Ponga el freno de estacionamiento y se debe eliminar adecuadamente. No lo elimine con los desechos domésticos. Consulte con las autoridades, centro de servicio o distribuidor local para conocer sobre instalaciones seguras de desecho/reciclaje.

1. Aplique el freno de estacionamiento, luego levante la parte delantera del cortacésped levemente, poniendo bloques de madera debajo del eje delantero.
2. Desconecte el cable de la bujía y manténgalo lejos de ella.
3. Retire la varilla de nivel de aceite y suelte o retire la tapa de llenado de aceite en el motor.
4. Ponga un recipiente adecuado debajo del drenaje del aceite (Figura 16). Retire o abra el tapón de drenaje de aceite y deje que el aceite se drene completamente.
5. Si tiene filtro de aceite, cámbielo.
6. Vuelva a poner o cierre el tapón del drenaje y limpie el aceite que pudo haberse derramado. Elimine debidamente el aceite usado.
7. Vacíe lentamente el aceite nuevo en el llenado de aceite de motor. No llene en exceso. Después de agregar aceite, espere un minuto y luego revise el nivel de aceite.
8. Instale y apriete la varilla para medir el nivel de aceite, luego retire la varilla y revise el nivel de aceite. Debe estar en la parte superior del indicador lleno.
9. Inserte y apriete la varilla de nivel de aceite.



FIGURA 16

Cómo mantener el filtro de aire

⚠ ADVERTENCIA La gasolina y sus vapores son extremadamente inflamables y explosivos. El fuego o las explosiones pueden causar quemaduras graves o incluso la muerte.

- Nunca arranque ni haga funcionar el motor cuando se haya retirado el conjunto del depurador de aire o filtro de aire.

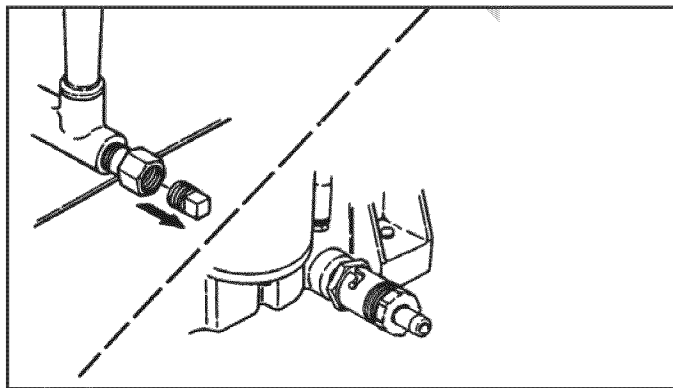
AVISO: No use aire presurizado ni solventes para limpiar el filtro. El aire presurizado puede dañar el filtro y los solventes pueden disolverlo.

1. Levante de la parte inferior de la traba (A, Figura 17) y tire la traba hacia fuera de la cubierta (B).
2. Retire la cubierta. Quite el filtro (C) y el depurador (D).
3. Para quitar en lo posible la suciedad, golpee suavemente el filtro contra una superficie dura.
4. Lave el depurador con detergente líquido y agua. Luego espere a que se seque completamente con el aire. No lubrique el depurador.
5. Instale el depurador con la malla hacia arriba. Instale el filtro.
6. Instale la cubierta cerciorándose de que las lengüetas se insertan en las correspondientes ranuras. Asegúrela con la traba.



FIGURA 17

ALMACENAMIENTO

Antes de almacenaje

Antes de guardar la unidad, realice los siguientes pasos:

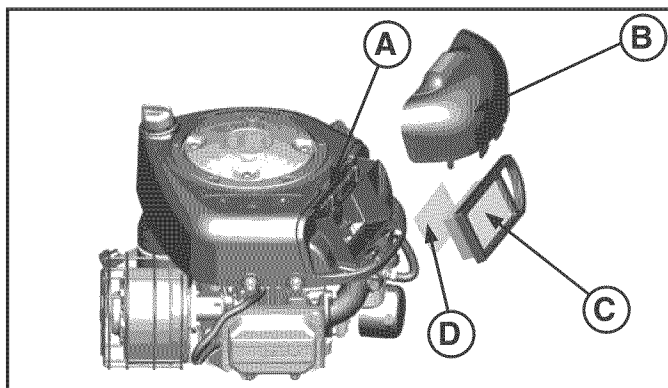
1. APAGUE la cuchilla del cortacésped, mueva la palanca de cambios de la transmisión a neutro (N), aplique el freno de estacionamiento y retire la llave desde el interruptor de encendido.
2. Revise los niveles de los líquidos. Compruebe todos los puntos del mantenimiento.
3. Retire la batería y guárdela en un lugar fresco. Recargue aproximadamente una vez al mes. Si la batería se deja instalada en la unidad, desconecte el cable negativo.

Después del almacenamiento

Antes de arrancar la unidad luego de que ha permanecido almacenada:

1. Revise los niveles de los líquidos. Compruebe todos los puntos del mantenimiento.
2. Llene el depósito con combustible NUEVO.
3. Después de poner la unidad en marcha, deje que se caliente el motor antes de utilizarla.

Proteja el sistema de combustible

El combustible se puede deteriorar cuando se almacena durante 30 días. El combustible deteriorado produce ácido y depósitos de resina que se forman en el sistema de combustible o en las piezas principales del carburador. Para mantener el combustible nuevo, use estabilizador de combustible Briggs & Stratton FRESH START®, que se vende como aditivo líquido o cartucho concentrado de goteo. No es necesario drenar la gasolina desde el motor si se agrega estabilizador de combustible según las instrucciones. Haga funcionar el motor durante 2 minutos para que el estabilizador circule a través del sistema de combustible. Luego se puede guardar el motor y el combustible hasta 24 meses. Si no se ha tratado la gasolina en el motor con algún estabilizador de combustible, se debe drenar en un recipiente homologado. Haga funcionar el motor hasta que se detenga por falta de combustible. Se recomienda el uso de algún estabilizador de combustible en el recipiente de almacenamiento para mantener la calidad del combustible como si fuera nuevo.

LOCALIZACIÓN DE FALLAS

Localización de fallas del tractor

PROBLEMA	BUSQUE	SOLUCIÓN
El motor no funciona ni arranca.	El pedal del freno no está presionado.	Presione por completo el pedal del freno.
	La palanca de la cuchilla del cortacésped está en posición ENCENDIDO.	Coloque la palanca de la cuchilla en la posición APAGADO.
	La ventilación de la tapa del depósito está cerrada.	Abra la ventilación de la tapa del depósito de combustible.
	Sin combustible.	Si el motor está caliente, déjelo enfriar y vuelva a llenar el tanque de combustible.
	El motor está ahogado.	Suelte el estrangulador.
	El fusible está quemado.	Consulte a un distribuidor autorizado.
	Los terminales de la batería requieren limpieza.	Revise la sección Limpieza la batería y los cables.
	La batería está descargada o muerta.	Recargue o sustituya la batería.
	El cableado está suelto o roto.	Revise visualmente el cableado. Si los cables están raídos o rotos, consulte al distribuidor autorizado.
	El solenoide o el motor de arranque está defectuoso.	Consulte a un distribuidor autorizado.
	El interruptor de bloqueo de seguridad está defectuoso.	Consulte a un distribuidor autorizado.
	Hay agua en el combustible.	Consulte a un distribuidor autorizado.
El gas es viejo o está muy usado.	Consulte a un distribuidor autorizado.	
El motor arranca con dificultad o funciona en forma deficiente.	La mezcla de combustible es demasiado rica.	Limpie el filtro de aire.
	El motor tiene otro problema.	Consulte a un distribuidor autorizado.
El motor golpea.	El nivel de aceite está bajo.	Revise o agregue aceite, según sea necesario.
	Se está usando aceite de una calidad incorrecta.	Consulte la Tabla de recomendaciones de aceite.
El consumo de aceite es excesivo.	El motor se calienta demasiado.	Consulte a un distribuidor autorizado.
	Se está usando aceite de una calidad incorrecta.	Consulte la Tabla de recomendaciones de aceite.
	El cárter tiene demasiado aceite.	Drene el exceso de aceite.
El escape del motor es negro.	El filtro de aire está sucio.	Consulte la sección Como mantener el filtro de aire.
	El estrangulador está cerrado.	Abra el estrangulador.
El motor funciona pero el tractor no avanza.	El disco de accionamiento está desgastado o no está ajustado.	Consulte a un distribuidor autorizado.
	El freno de estacionamiento está accionado.	Desenganche el freno de estacionamiento.

Localización de fallas del tractor

PROBLEMA	BUSQUE	SOLUCIÓN
El freno no se mantiene.	El freno interno está desgastado.	Consulte a un distribuidor autorizado.
La dirección del tractor está dura o su manejo es deficiente.	El varillaje de dirección está suelto.	Consulte a un distribuidor autorizado.
	El inflado del neumático es inadecuado.	Consulte la sección Verificación de la presión de los neumáticos.
	Los rodamientos del eje portamuela delantero están secos.	Consulte a un distribuidor autorizado.

Localización de fallas del cortacésped

PROBLEMA	BUSQUE	SOLUCIÓN
El cortacésped no se eleva.	El varillaje de elevación no está conectado en forma adecuada o presenta daños.	Consulte a un distribuidor autorizado.
El corte del cortacésped es irregular.	El cortacésped no está nivelado en forma adecuada.	Consulte a un distribuidor autorizado.
	Los neumáticos del tractor no están inflados en forma apropiada.	Consulte la sección Verificación de la presión de los neumáticos.
El corte del cortacésped luce irregular.	La velocidad del motor es demasiado lenta.	Ajústelo a toda marcha.
	La velocidad de avance es demasiado alta.	Disminúyala.
	El cortacésped tiene otro problema.	Consulte a un distribuidor autorizado.
El motor se detiene con facilidad con el cortacésped accionado.	La velocidad del motor es demasiado lenta.	Ajústelo a toda marcha.
	La velocidad de avance es demasiado rápido.	Disminúyala.
	El filtro de aire está sucio u obstruido.	Consulte la sección Como mantener el filtro de aire.
	La altura de corte es muy baja.	Corte el césped largo a la altura máxima de corte durante la primera pasada.
	Conducto de descarga atascado.	Corte el césped con la dirección de descarga hacia el área que cortó con anterioridad.
	El motor no alcanza la temperatura de funcionamiento.	Arranque el motor durante algunos minutos para calentarlo.
	Arranca el cortacésped en césped alto.	Arranque el motor en un área limpia.
Vibración excesiva del cortacésped.	La cuchilla de corte o la correa de la plataforma están dañadas.	Consulte a un distribuidor autorizado.
El motor funciona y el tractor tiene tracción, pero el cortacésped no se mueve.	Correa de plataforma floja o dañada.	Consulte a un distribuidor autorizado.

ESPECIFICACIONES TÉCNICAS

Modelo N° 107.280340	
Largo total	162,6 cm (64 pulg.)
Ancho total	81,3 cm (32 pulg.)
Tamaño de la plataforma	71,1 cm (28 pulg.)
Altura de corte (5 posiciones)	3,8 a 10,2 cm (1,5 a 4,0 pulg.)
Tipo de transmisión	Transmisión de 5 velocidades por discos
Presión de los neumáticos	12 psi
Radio de giro	71,1 cm (28 pulg.)
Potencia del motor (hp)	12,5
Desplazamiento del motor (cc)	344 cc
Capacidad de aceite del motor	1,2 a 1,3 litros (42 a 44 onzas)
Capacidad del depósito de combustible	6,6 litros (7 cuartos de galón)
Separación de las bujías	0,030 pulg.
Peso	142,4 kg (314 lb)

Repuestos comunes	Número de pieza
Cuchilla del cortador (elevador estándar por aire de 71 cm [28 pulg.])	7019515
Correa de la plataforma de corte de 71 cm (28 pulg.)	7022252
Cartucho del filtro de aire	698413 ó 5079
Predepurador del filtro de aire	697292 ó 5079
Estabilizador de combustible	5041
Bujía	491055

Información de clasificación de potencia del motor La clasificación de potencia bruta para el modelo de motor de gasolina individual está etiquetada de acuerdo con el código J1940 (Small Engine Power & Torque Rating Procedure) de la SAE (Society of Automotive Engineers), y la clasificación de rendimiento ha sido obtenida y corregida de conformidad con SAE J1995 (Revisión 2002-05) Los valores de pares motor han sido obtenidos a 3060 RPM; los valores de caballos de fuerza han sido obtenidos a 3600 RPM. La potencia bruta real del motor resultará disminuida y se verá afectada por, entre otros elementos, las condiciones ambientales de funcionamiento y variabilidad entre motores. Dado el amplio conjunto de productos en que son colocados los motores y la variedad de cuestiones ambientales pertinentes para el funcionamiento del equipo, el motor de gasolina no desarrollará la potencia nominal bruta cuando sea utilizado en un componente dado de equipamiento de motor (caballos de fuerza efectivos "in situ" o netos). Estas diferencias se deben a una amplia variedad de factores, incluidos entre otros, accesorios (limpiadores de aire, tubos de escape, carga, refrigeración, carburador, bomba de combustible), limitaciones de aplicación, condiciones ambientales de funcionamiento (temperatura, humedad, altitud), y la variabilidad entre motores. A causa de las limitaciones de fabricación y de capacidad, Briggs & Stratton podrá sustituir una mayor potencia clasificada para este motor de serie.

Repair Parts

Not for
Reproduction

NOTE: Unless noted otherwise,
use the standard hardware torque
specification chart.

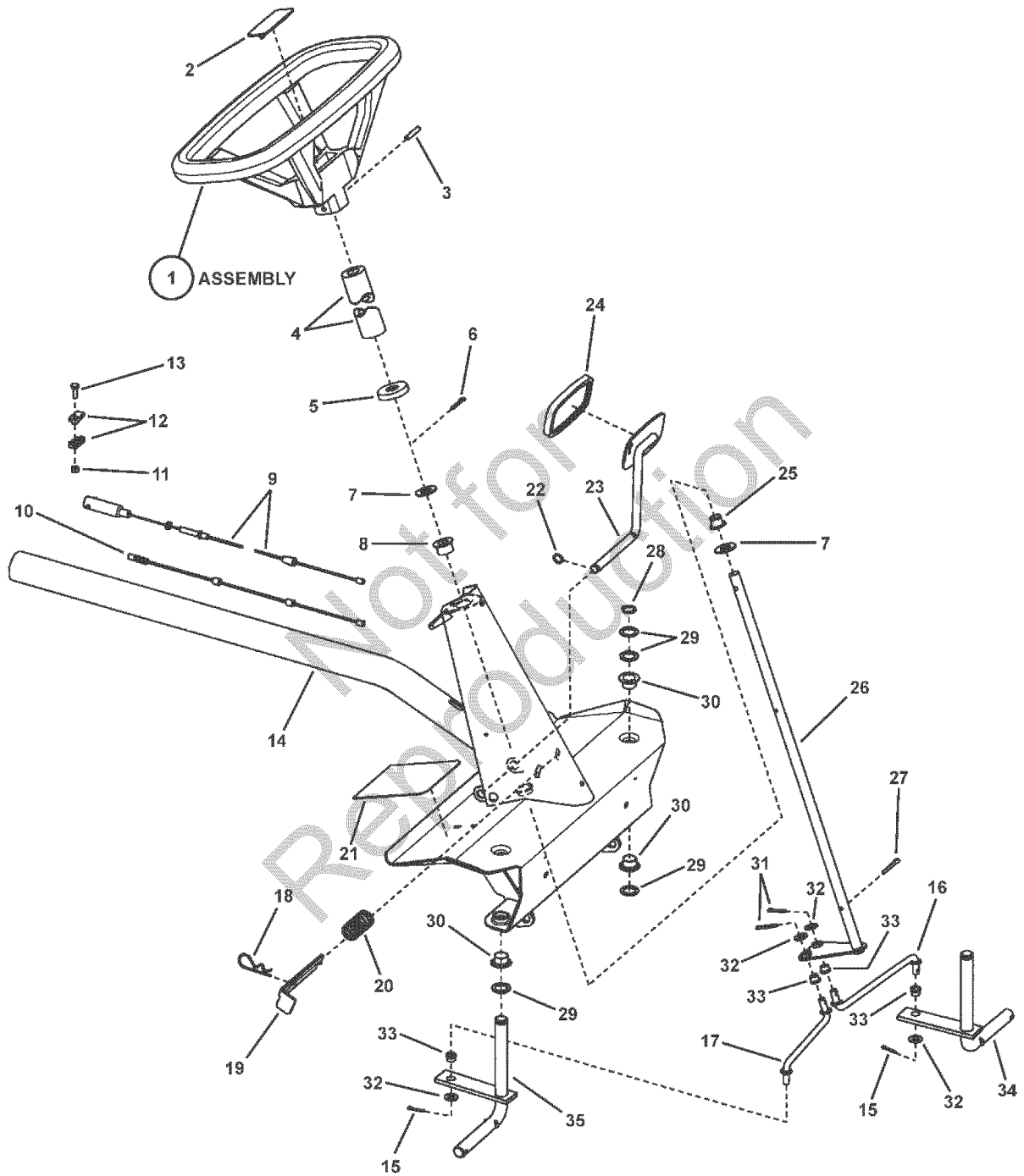

Front End & Steering Group

CRAFTSMAN 28" 107.280340

REF NO	PART NO.	QTY.	DESCRIPTION
1	7501813YP	1	ASSEMBLY, Steering Wheel (for 5/8" shaft) (Includes Ref. No. 2)
2	7103982YP	1	PLATE, Center, Steering Wheel
3	7013862YP	1	ROLL PIN, 1/4 x 1-1/2"
4	7023667YP	1	FOAM COVER, Steering Shaft
5	7023671YP	1	COVER, Steering Shaft
6	7090296YP	1	PIN, 3/16 x 1" Cotter
7	7090183YP	2	WASHER, .66 x 1.31 x .09 Flat
8	7046158YP	1	BUSHING, Nylon
9	7101192YP	1	CABLE, Brake, Snap-In
10	7022449YP	1	CABLE, Clutch/Brake (54.32" long)
11	7090372SM	1	NUT, 1/4-20 Hex Center Lock, GR 5 or B
12	7034174YP	2	CONNECTOR, Cable
13	7091495SM	1	SCREW, 1/4-20 x 3/4" Hex Head Cap, GR 5
14	7054378YP	1	WELDMENT, Front Axle, Narrow
15	7090365YP	2	PIN, 1/8 x 3/4" Cotter
16	7013023YP	1	TIE ROD, Left Hand (7.41" long)
17	7012933YP	1	TIE ROD, Right Hand (7.41" long)
18	7011714YP	1	HAIR PIN, 2-1/4"
19	7038243DYP	1	LATCH, Parking Brake
20	7015444YP	1	SPRING, Parking Brake Latch
21	7014049YP	2	FOOT PAD, Short (5.5" x 4.7")
22	7010776YP	1	RING, 1/2" External Retaining (Heavy Duty)
23	7047888BMYP	1	WELDMENT, Clutch Pedal
24	7011815YP	1	PAD, Pedal
25	7010694YP	1	BUSHING, Nylon
26	7046232YP	1	WELDMENT, Steering Shaft
27	7090753YP	1	PIN, 3/16 x 1-1/2" Cotter
28	7010746YP	2	RING, 5/8" External Retaining
29	7010935SM	6	WASHER, .77 x 1.13 x .06 Flat
30	7010986YP	4	BEARING, Nylon
31	7090364YP	2	PIN, 5/32 x 1" Cotter
32	7090122YP	4	WASHER, 3/8" Flat SAE
33	7013321YP	4	BUSHING, Tie Rod
34	7041687YP	1	WELDMENT, King Pin, Left Hand
35	7041688YP	1	WELDMENT, King Pin, Right Hand

Footnotes

NOTE: Unless noted otherwise,
use the standard hardware torque
specification chart.

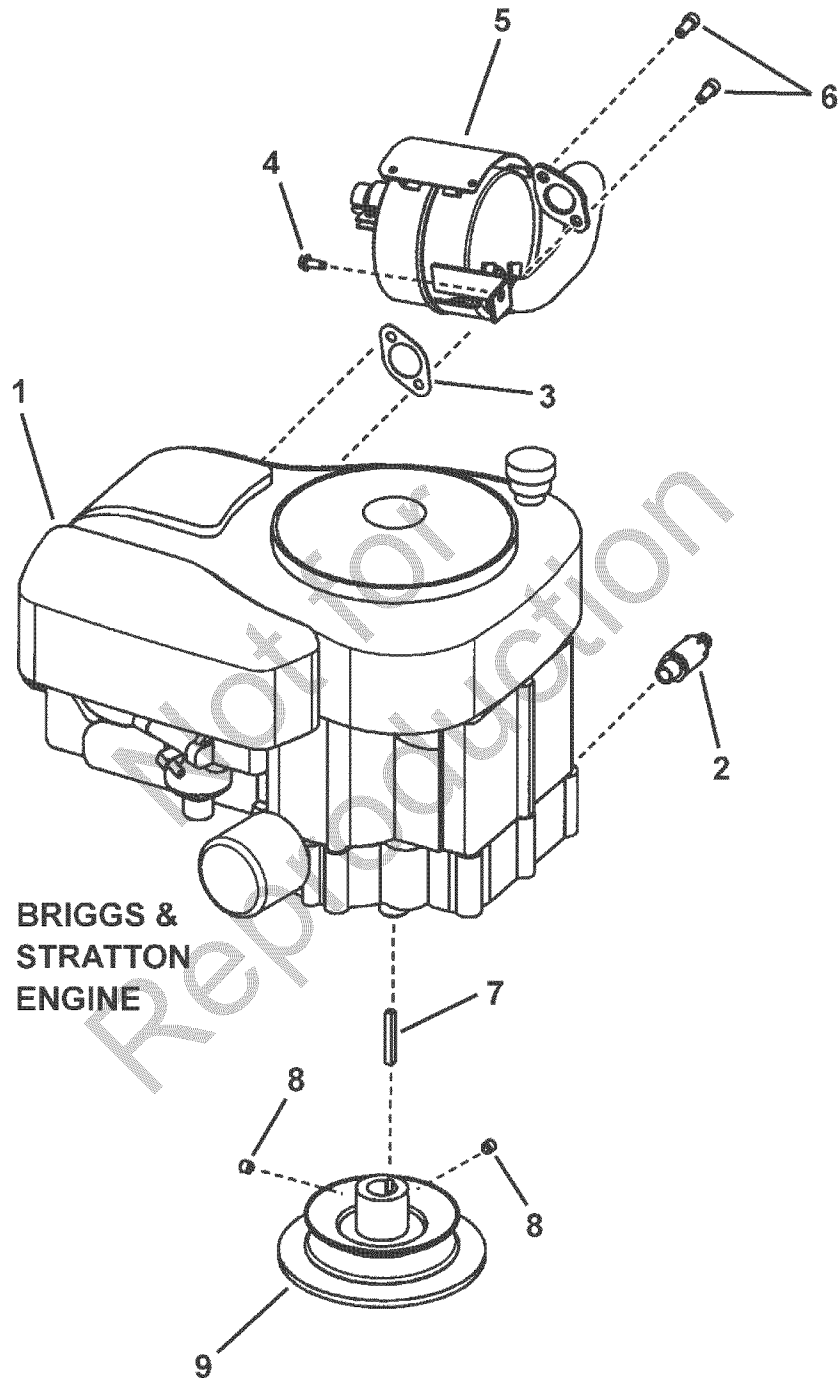

Engine, Muffler & Drive Disc Group**CRAFTSMAN 28" 107.280340**

REF NO	PART NO.	QTY.	DESCRIPTION
1	219977-0130-B1	1	* ENGINE, 12.5HP Briggs Intek OHV, E. S. No Recoil electric start
2	7027972SM	1	ASSEMBLY, Oil Valve
3	7015352SM	1	GASKET, Exhaust
4	7090362YP	2	SCREW, 1/4-20 x 5/8" Hex Washer Head Self-Tap
5	7074453YP	1	MUFFLER, w/Heat Shield (Briggs 11 thru 17.5HP)
6	7091738SM	2	SET SCREW, 5/16-18 x 3/4" Socket Head, GR8
7	7010210SM	1	KEY, 1/4" Square x 2" Long
8	7090132YP	2	SET SCREW, HRSS, 3/8-16 x 3/8"
9	7072658YP	1	WELDMENT, 5.75" O.D. Drive Disc
10	7091576SM	1	NUT, 1/4-20 Hex, GR 5 or B (not shown) (attaches to starter terminal)

Not for
reproduction

Footnotes

Note: * Purchase engine parts from engine manufacture dealer.

Gear Shift Assembly

CRAFTSMAN 28" 107.280340

NOTE: Unless noted otherwise, use the standard hardware torque specification chart.

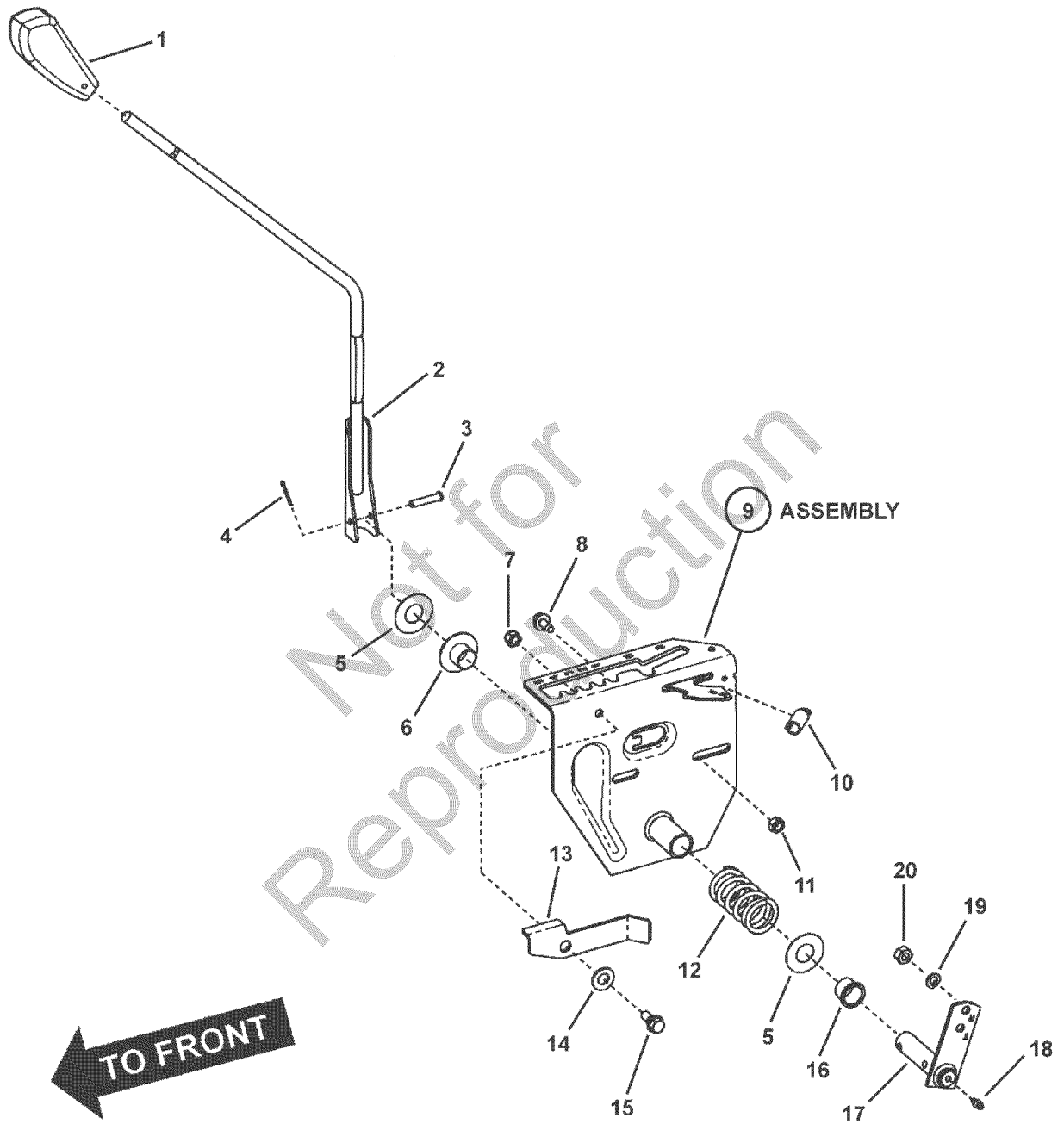

Gear Shift Assembly**CRAFTSMAN 28" 107.280340**

REF NO	PART NO.	QTY.	DESCRIPTION
1	7023656YP	1	GRIP, Shift Handle
2	7059212YP	1	WELDMENT, Shift Handle
3	7023914YP	1	PIN, 1/4 x 1-3/4" Tapered Clevis
4	7090037YP	1	PIN, 3/32 x 3/4" Cotter
5	7031036YP	2	WASHER, Thrust
6	7019245YP	1	BUSHING, 3/4 x 1.62 Flange (Nylon)
7	7091298YP	1	NUT, 5/16-18 Hex Nyloc
8	7090361YP	1	SCREW, 5/16-18 x 5/8" Hex Washer Self-Tap
9	7058763YP	1	ASSEMBLY, Speed Adjustment Latch (Includes Ref. No. 10)
10	7026292YP	1	SPRING part of Speed Adjustment Latch Ass'y
11	7090196YP	1	NUT, 5/16-18 Hex, GR 5 or B
12	7010754YP	1	SPRING, Shift Detent
13	7073289YP	1	LEVER, Over-Ride
14	7091595SM	1	WASHER, .47 x .92 x .065 Flat
15	7015761YP	1	SHOULDER BOLT, 5/16-18
16	7019246YP	1	BUSHING, 3/4 x I.O. Flange (Nylon)
17	7043201YP	1	WELDMENT, Arm, Shift Handle (w/grease ftg. Hole)
18	7010817SM	1	LUBE FITTING, 3/16" Press-In
19	7091315SM	1	WASHER, .32 x .58 x .08 Split Lock
20	7091297SM	1	NUT, 5/16-24 Hex, GR 5

Footnotes

NOTE: Unless noted otherwise, use the standard hardware torque specification chart.

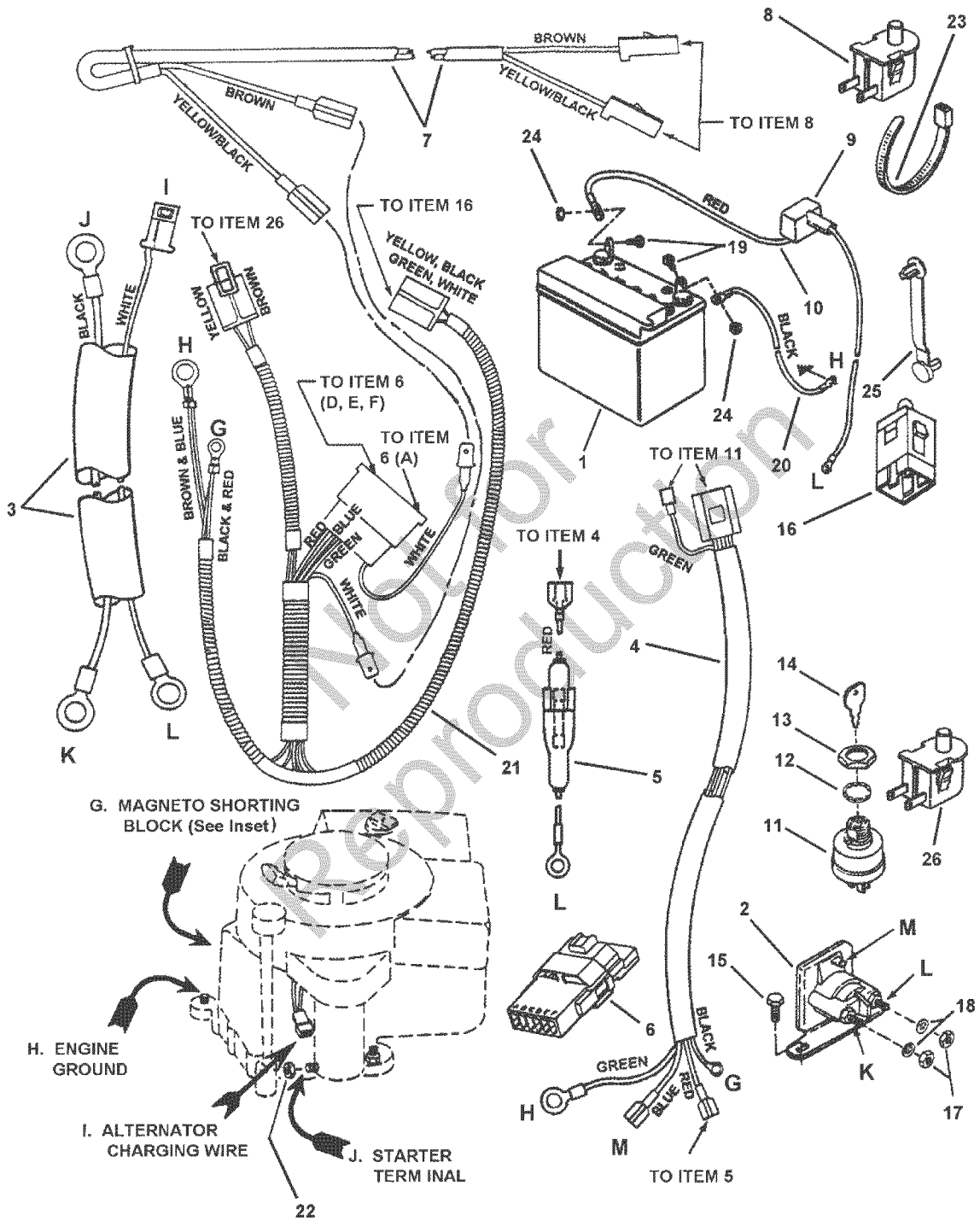

REF NO	PART NO.	QTY.	DESCRIPTION
1	7075373YP	1	BATTERY, 12V 140CCA L Terminal
2	7075671YP	1	SOLENOID, Super-Trombetta
3	7022788YP	1	HARNESS, Starter Wiring (Briggs Engines)
4	7073715YP	1	HARNESS, Ignition Wiring (Briggs Engines)
5	7016168YP	1	HOLDER, Fuse (Includes Fuse)
--	7016169YP	1	FUSE, 10 Amp (Not shown)
6	7028606YP	1	INTERLOCK MODULE, Briggs
7	7028386YP	1	HARNESS (Deck Interlock Wiring)
8	7018524YP	1	SWITCH, Deck Interlock (NO)
9	7012444YP	1	COVER, Battery Cable
10	7019326YP	1	WIRE, Positive (Red, 17" long)
11	7073797YP	1	SWITCH, Ignition, 4 Terminal, Indak
12	7090880YP	1	WASHER, 5/8" Internal Tooth Lock
13	7015438YP	1	NUT, 5/8-32 Hex
14	7011138YP	1	IGNITION KEY, Pair
15	7090539YP	3	SCREW, 1/4-20 x 1/2" Hex Washer Self-Tap
16	7022886YP	1	SWITCH, Operator Presence Control (OPC) Traction (NC/NO)
17	7091576SM	4	NUT, 1/4-20 Hex, GR 5 or B
18	7090053SM	2	WASHER, 1/4" Internal Tooth Lock
19	7027172YP	2	SCREW, 1/4-20 x 5/8" Hex Head Cap. GR 5
20	7028027YP	1	WIRE, Negative, Black (15" long)
21	7028607YP	1	HARNESS, Operator Presence Control (OPC) Wire
22	7091576SM	1	NUT, 1/4-20 Hex, GR 5 or B
23	7012080SM	2	CABLE TIE, 7"
24	7090372SM	2	NUT, 1/4-20 Hex Center Lock, GR 5 or B
25	7014451YP	1	CABLE TIE
26	7023354YP	1	SWITCH, Seat (NC)

Footnotes

NOTE: Unless noted otherwise,
use the standard hardware torque
specification chart.

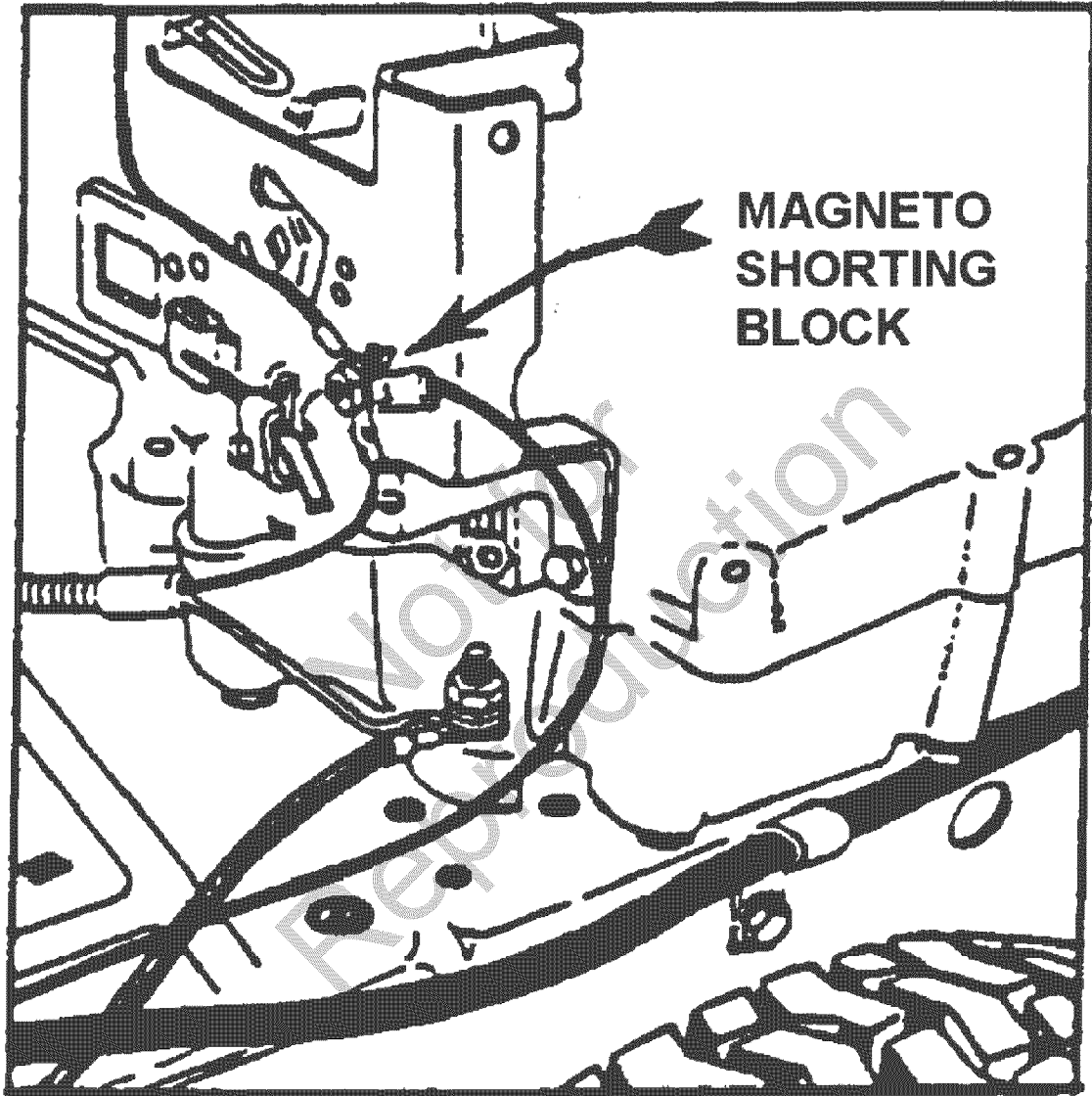

REF NO	PART NO.	QTY.	DESCRIPTION
--	--		View shows engine magneto ground connection on throttle plate

Not for
reproduction

Footnotes

NOTE: Unless noted otherwise, use the standard hardware torque specification chart.

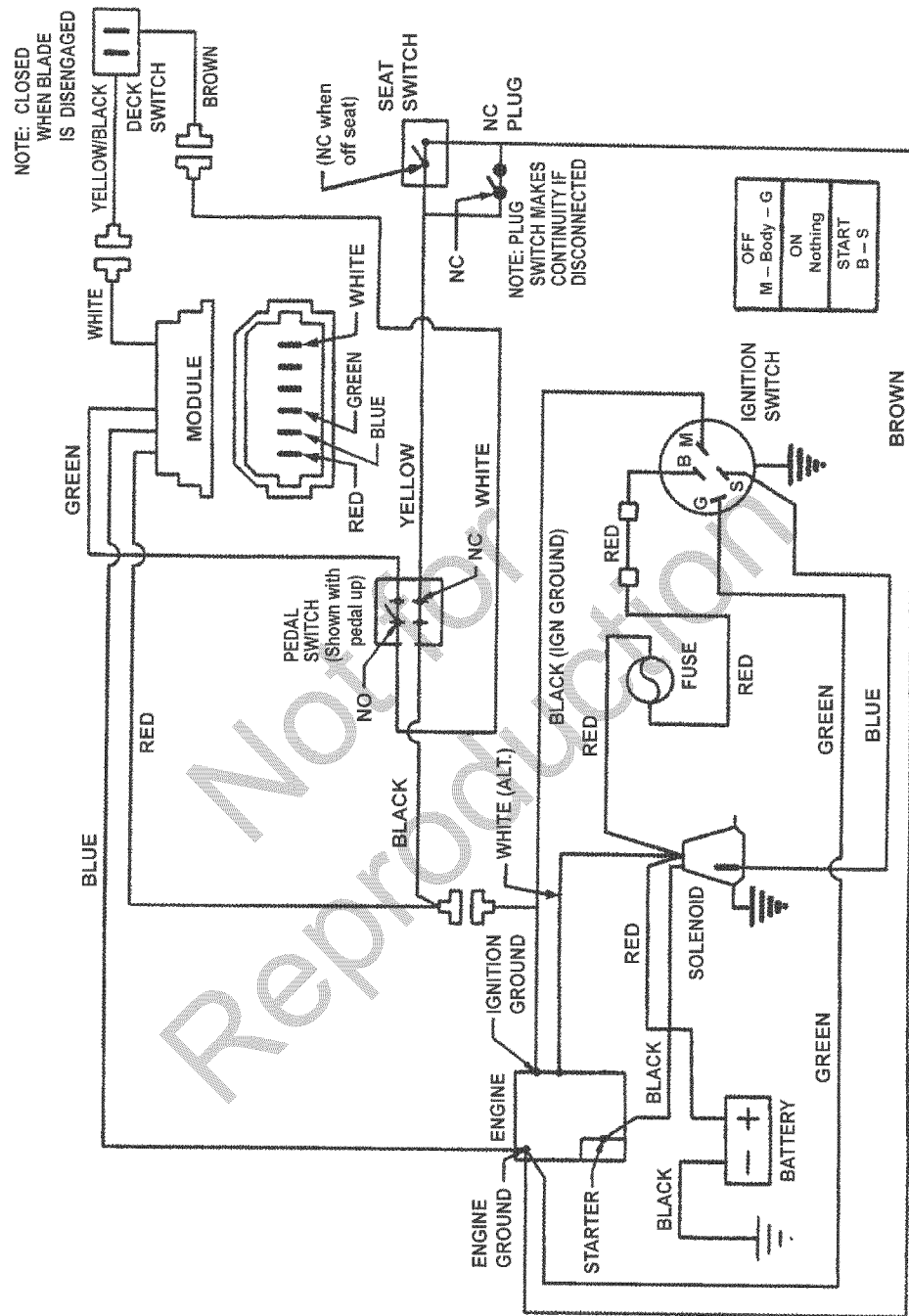

WIRING SCHEMATIC FOR 12.5HP Briggs Engines

REF NO	PART NO.	QTY.	DESCRIPTION
	----		Electrical Schematic

Not for
reproduction

Footnotes

NOTE: Unless noted otherwise,
use the standard hardware torque
specification chart.

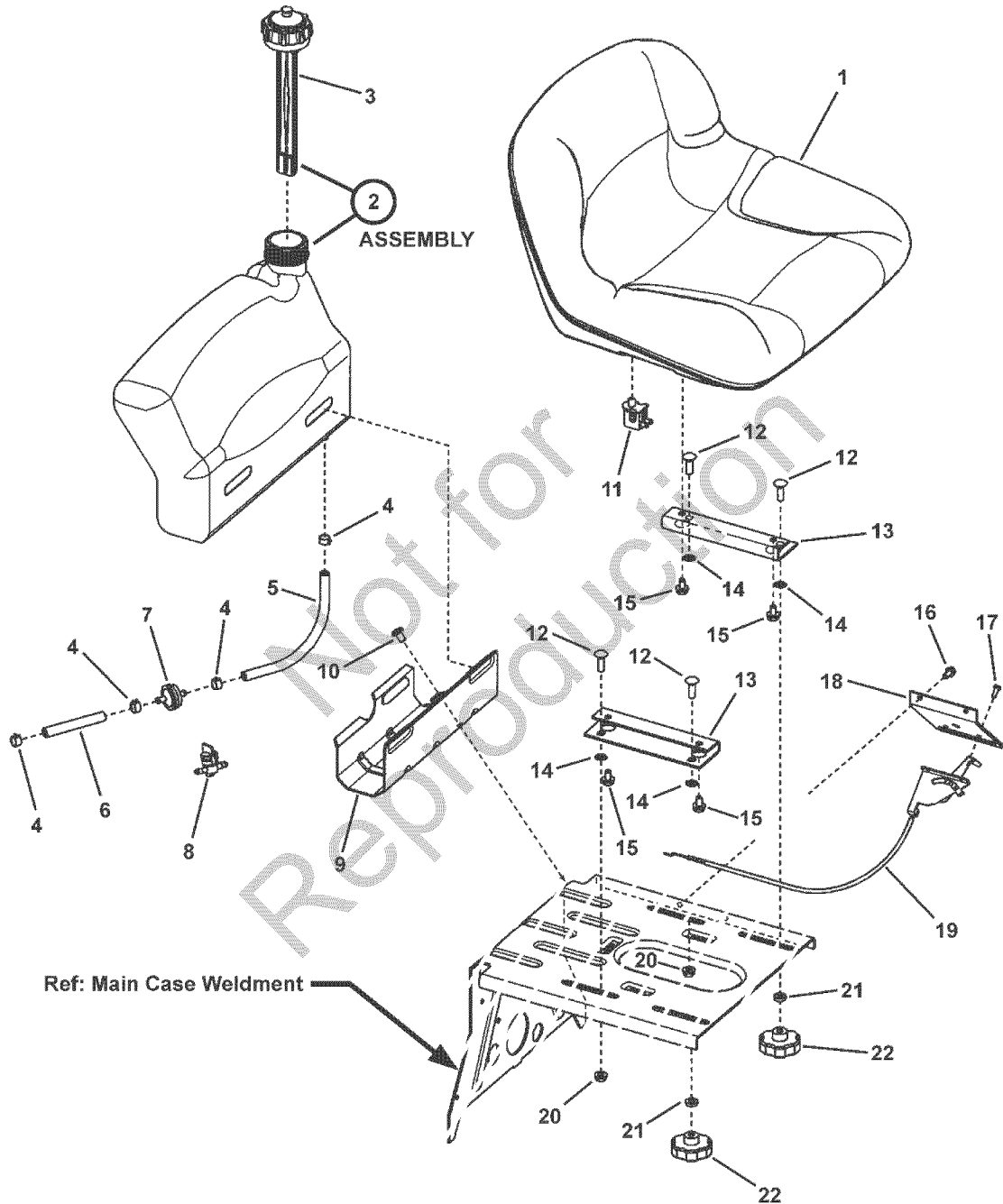

Fuel Tank & Seat Group**CRAFTSMAN 28" 107.280340**

REF NO	PART NO.	QTY.	DESCRIPTION
1	885172YP	1	SEAT, V2405 w/Switch Hole, No Graphics
2	7052435YP	1	ASSEMBLY, Fuel Tank with Gauge (Includes Ref. No. 3)
3	7019377YP	1	CAP, with Gauge
4	7029900SM	2	CLAMP, Fuel Line
5	791766	1	HOSE, Fuel (1/4" I.D. x 8-1/2" long) (Cut to Length 8 1/2" long)
6	791766	1	HOSE, Fuel (1/4" I.D. x 3-1/2" long) (Cut to Length 3 1/2" long)
7	7014359YP	1	FILTER, Fuel (In-Line)
8	7024507YP	1	VALVE, Fuel Shut-Off (Accessory)
9	7033377BMYP	1	BRACKET, Fuel Tank (Rear)
10	7091542SM	2	SCREW, 5/16-18 x 1/2" Pan Head Self-Tap (Torx #T-40)
11	7023354YP	1	SWITCH, Seat (NC)
12	7091714YP	4	BOLT, 5/16-18 x 1" Square Neck Carriage, GR 5
13	7075018BMYP	2	BRACKET, Seat
14	7011791SM	4	RETAINER, 5/16" Bolt
15	7091038YP	2	BOLT, 5/16-18 x 1/2" Hex Flange Nyloc
16	7090362YP	2	SCREW, 1/4-20 x 5/8" Hex Washer Self-Tap
17	7090913SM	2	SCREW, #10-24 x 1/2" Hex Washer Self-Tap (Torx)
18	7033470YP	1	PLATE, Throttle Control
19	7022751YP	1	CONTROL, Throttle (23.6" long)
20	7090951SM	2	NUT, 5/16-18 Hex Flange Top Lock
21	7013849YP	2	SPACER, .33 x .63 x .156
22	7023735YP	2	KNOB, Fluted, 5/16-18 internal thread (2.15 O.D.)

Footnotes

NOTE: Unless noted otherwise,
use the standard hardware torque
specification chart.

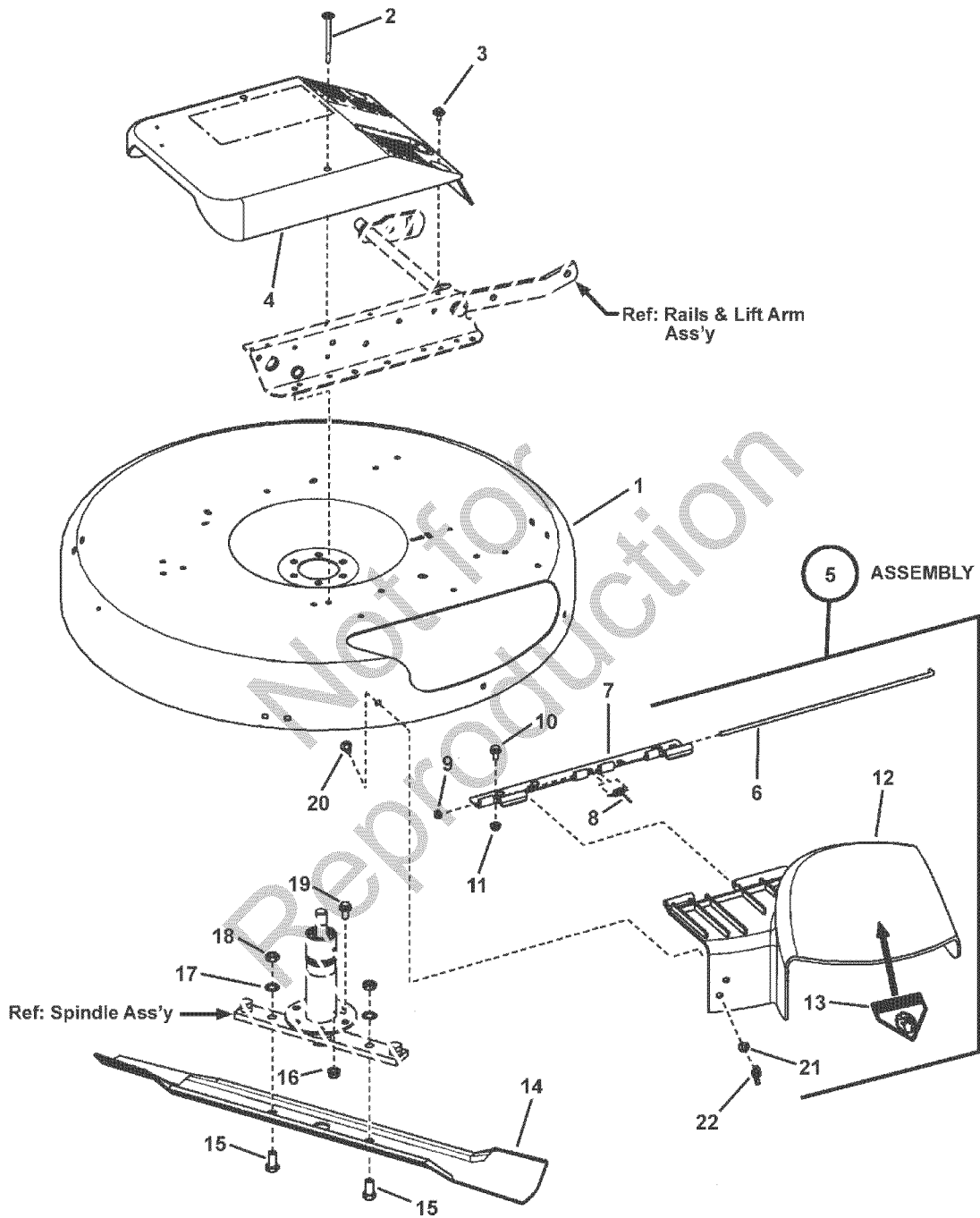

28" Hi-Vac Cutting Deck & Deflector**CRAFTSMAN 28" 107.280340**

REF NO	PART NO.	QTY.	DESCRIPTION
1	7061970YP	1	DECK, 28" Replacement (Painted deck w/decals & wheel bracket fasteners)
2	7091015YP	2	SCREW, 1/4-20 x 3-1/2" Hex Head w/Free Spinning Washer
3	7091016YP	4	SCREW, 1/4-20 x 5/8" Hex Head w/Free Spinning Washer
4	7073434YP	1	COVER, Spindle
5	7500484YP	1	ASSEMBLY, Discharge Deflector, 28" without decal (Includes Ref. Nos. 6, 7, 8, 9 & 12)
6	7026234YP	1	PIN, Hinge
7	7300886BMYP	1	HINGE, Deflector (Deck side)
8	7016341YP	1	SPRING, Hinge
9	7026483YP	2	PUSH NUT, 1/4"
10	7091811SM	3	BOLT, 5/16-18 x 5/8" Hex Flange Lock, GR 5
11	7091070YP	2	NUT, 5/16-18 Hex Flange Lock, GR 5
12	7026233YP	1	DEFLECTOR, Discharge, 28"
13	7013010SM	1	DECAL, Danger, (Cut Finger)
14	7600103YP	1	BLADE, Replacement Kit, 28"
15	7090491YP	2	SCREW, 1/2-20 x 1-1/4" Hex Head Cap, GR 5
16	7090613YP	9	NUT, 3/8-16 Hex Flange Lock
17	7090509YP	2	WASHER, 1/2" Internal Tooth Lock
18	7091939YP	2	NUT, 1/2-20 Hex, GR 5 or B
19	7090612YP	3	BOLT, 3/8-16 x 3/4" Hex Flange Lock
20	7091508SM	2	BOLT, 5/16-18 x 3/4" Short Neck Carriage, GR 5
21	7091296YP	2	WASHER, 5/16" Flat
22	7090492YP	2	NUT, 5/16-18 Wing

Footnotes

NOTE: Unless noted otherwise,
use the standard hardware torque
specification chart.

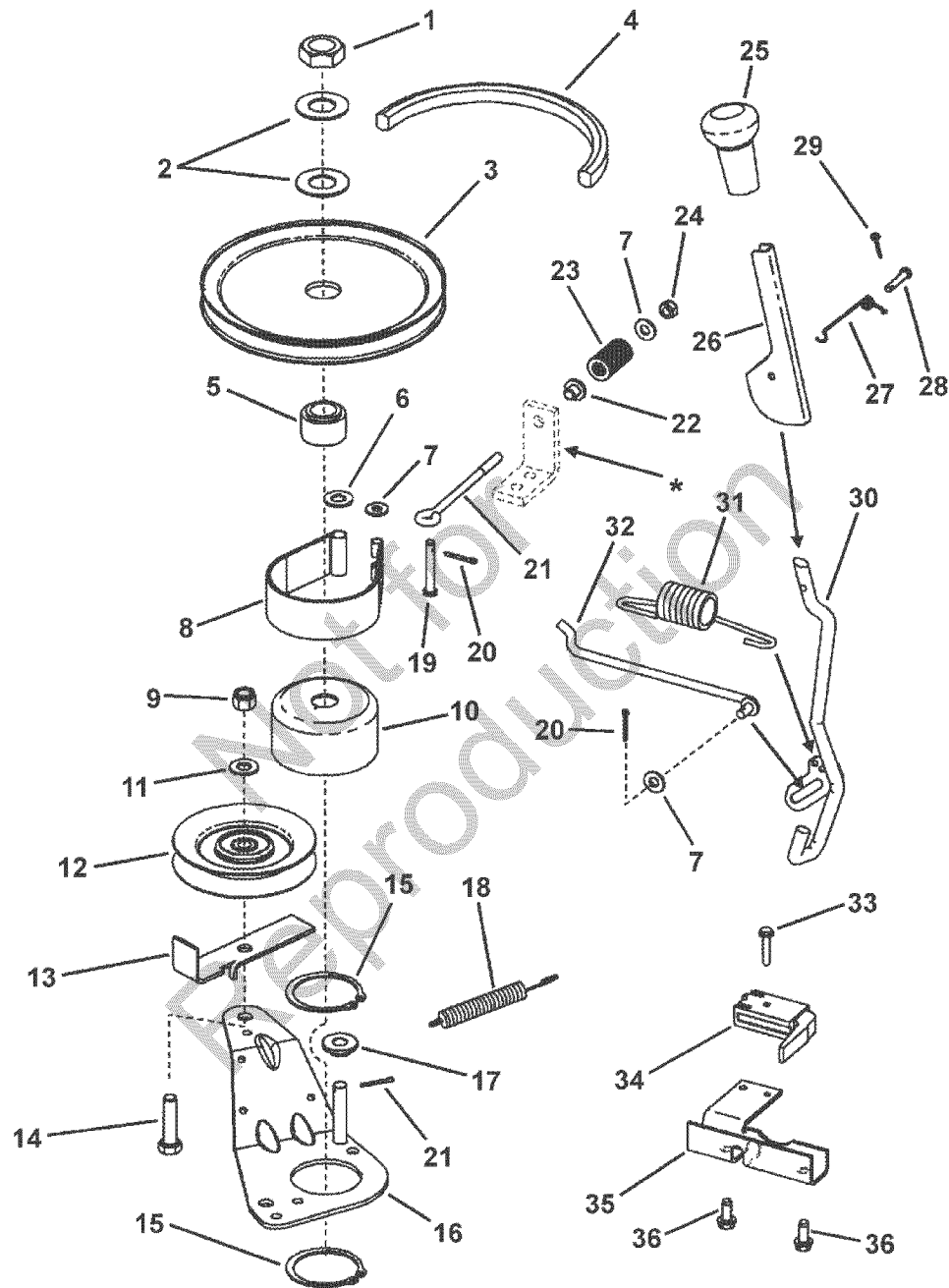

* Ref: Rails, Lift Arms & Cam Lift Group, Item # 38

REF NO	PART NO.	QTY.	DESCRIPTION
1	7074467SM	1	NUT, 3/4-16 Hex Jam, GR 8
2	7032027SM	2	WASHER, 49/64" I.D. x 1-1/2" O.D. Flat
3	7018781YP	1	PULLEY, Deck
4	7022252YP	1	* BELT, Drive (72.75" AA Section)
5	7015290YP	1	PULLEY, Hub (Powdered Metal)
6	7090122YP	1	WASHER, 3/8" Flat SAE
7	7091294SM	3	WASHER, 1/4" Flat
8	7034852YP	1	BAND, Brake (Formed)
9	7091299SM	1	NUT, 3/8-16 Hex Nyloc
10	7035378YP	1	DRUM, Brake Spindle
11	7091514YP	1	WASHER, 3/8" Flat
12	7029624YP	1	IDLER PULLEY, 4" Idler
13	7032111YP	1	RESTRICTOR, Belt
14	7091497SM	1	SCREW, 3/8-16 x 1-1/2" Hex Head Cap, GR 5
15	7010740YP	2	RING, 2" External Retaining
16	7047787YP	1	WELDMENT, Idler Arm
17	7014314YP	1	SPACER, .39 x 1.0 x .31 Nylon
18	7036521YP	1	SPRING, Extension, 4" x 1/2" Diameter
19	7014304YP	1	PIN, 1/4 x 1-5/8" Clevis
20	7091597SM	3	PIN, 3/32 x 3/4" Cotter
21	7046677YP	1	EYE-BOLT, 1/4-20 x 4"
22	7014343YP	1	BUSHING, Flange .27 x .35 x .4
23	7046782YP	1	SPRING, Rectangular Wire Die, Blue
24	7090761YP	1	NUT, 1/4-20 Hex Top Lock
25	7046874YP	1	GRIP, Handle
26	7046567BMYP	1	HANDLE, Blade Engagement (Flip)
27	7046648YP	1	SPRING, Torsion, Flip Handle
28	7091974YP	1	PIN, 3/16 x 1" Clevis
29	7090555YP	1	PIN, 3/32 x 1/2" Cotter
30	7059254YP	1	WELDMENT, Blade Engagement Handle
31	7014168YP	1	SPRING, Blade Handle
32	7012055YP	1	ROD, Idler Control
33	7090299YP	1	SCREW, #10-32 x 1" Hex Washer Head Self-Tap
34	7018524YP	1	SWITCH, Deck Interlock (NO)
35	7038021YP	1	MOUNT, Handle/Switch
36	7090362YP	2	SCREW, 1/4-20 x 5/8" Hex Washer Head Self-Tap

Footnotes

Note: * Belt part numbers are printed on belts.

Yoke Lift Components

CRAFTSMAN 28" 107.280340

NOTE: Unless noted otherwise, use the standard hardware torque specification chart.

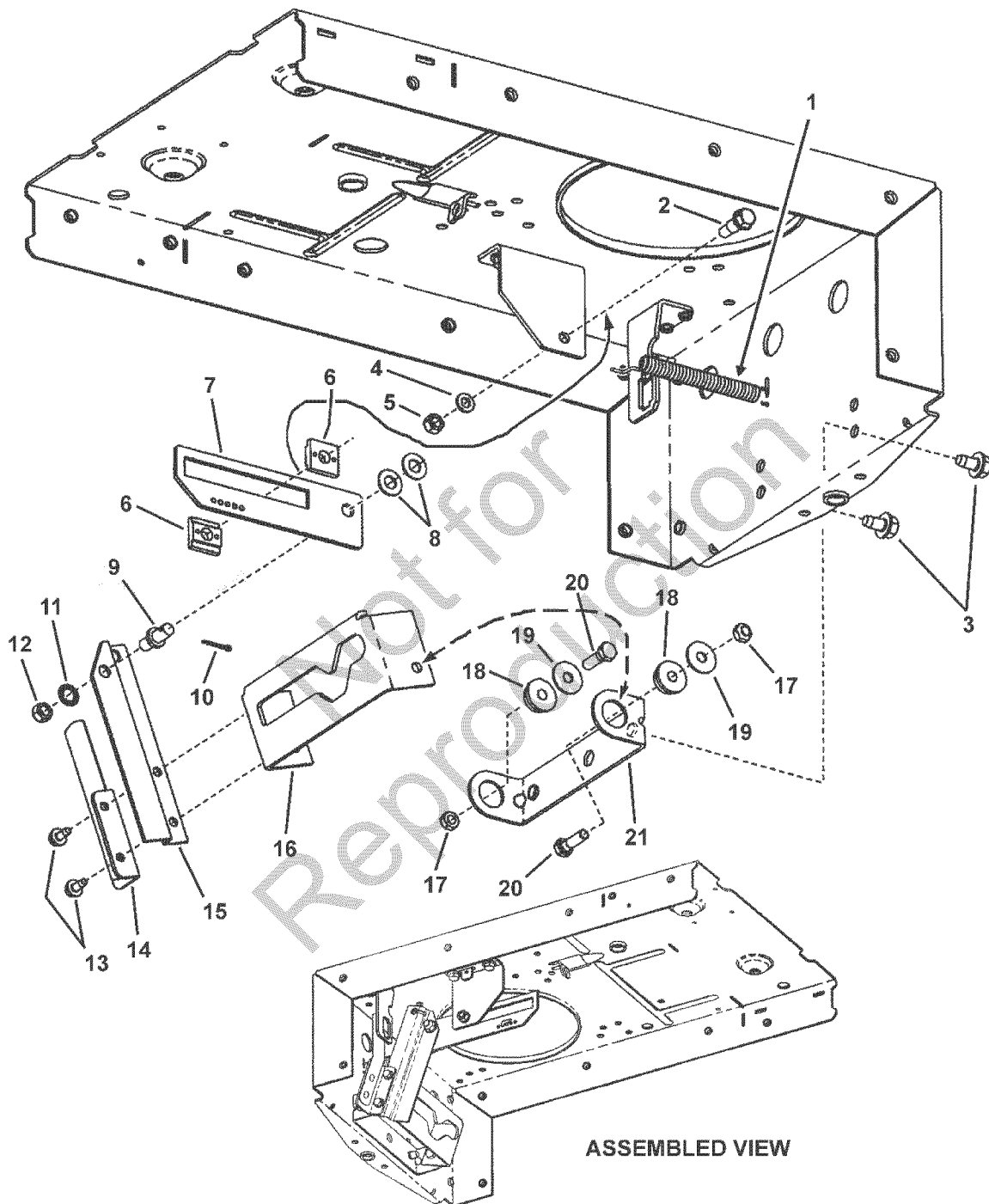

ASSEMBLED VIEW

Yoke Lift Components**CRAFTSMAN 28" 107.280340**

REF NO	PART NO.	QTY.	DESCRIPTION
1	7013885YP	1	SPRING, Clutch & Brake
2	7014664SM	1	BOLT, 5/16-18 Shoulder
3	7091198SM	2	SCREW, 3/8-16 x 5/8" Hex Washer Self-Tap
4	7090187SM	1	WASHER, 5/16" Split Lock
5	7090196YP	1	NUT, 5/16-18 Hex, GR 5 or B
6	7014663YP	2	SLIDE HALF
7	7047190YP	1	BRACKET, Slide
8	7090122YP	2	WASHER, 3/8" Flat SAE
9	7015464YP	1	STUD, Clutch Link (3/8-24 thread)
10	7090037YP	1	PIN, 3/32 x 3/4" Cotter
11	7090390SM	1	WASHER, 3/8" Internal Tooth Lock
12	7090155YP	1	NUT, 3/8-24 Hex, GR 5 or B
13	7090539YP	2	SCREW, 1/4-20 x 1/2" Hex Washer Self-Tap
14	7059068YP	1	ASSEMBLY, Leaf Spring
15	7073733YP	1	ARM, Yoke
16	7046162YP	1	LIFT, Yoke
17	7011201YP	2	NUT, 5/16-24 Hex Center Lock
18	7011048YP	2	BEARING, Yoke
19	7011763SM	2	FENDER WASHER, 5/16"
20	7090238SM	2	SCREW, 5/16-24 x 1" Hex Head Cap, GR 5
21	7033291YP	1	COLLAR, Yoke

Footnotes

NOTE: Unless noted otherwise,
use the standard hardware torque
specification chart.

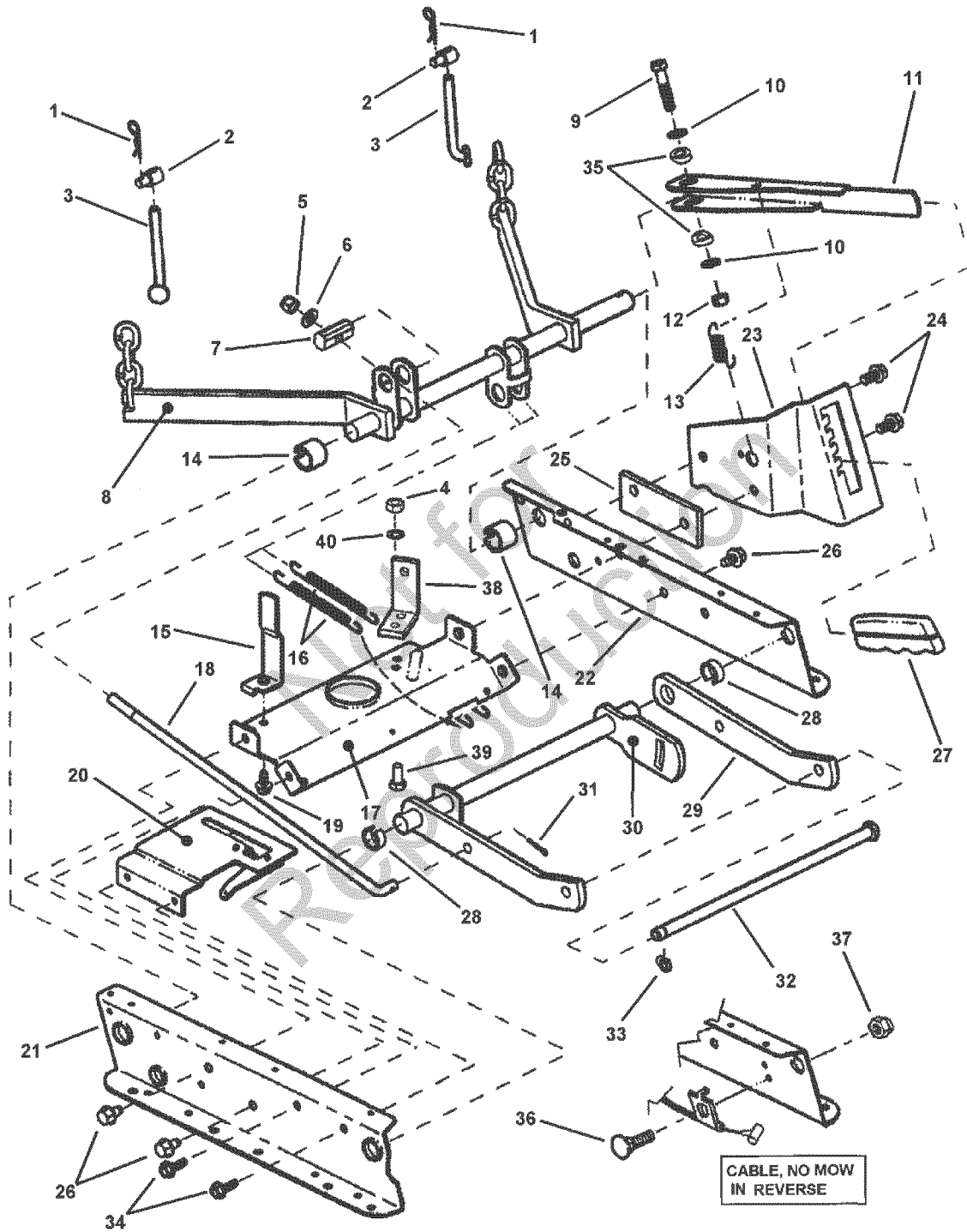

REF NO	PART NO.	QTY.	DESCRIPTION
1	7091503SM	2	HAIR PIN, 3/32 x 1-1/2"
2	7028200SM	2	SWIVEL, Adjustable
3	7028728SM	2	ADJUSTER, Chain (5/16-18 thread)
4	7091297SM	2	NUT, 5/16-24 Hex
5	7090854YP	1	NUT, 3/8-24 Hex Nyloc
6	7090122YP	1	WASHER, 3/8" Flat SAE
7	7034213YP	1	PIVOT, Leveling
8	7059324YP	1	WELDMENT, Rear Lift Arm
9	7090483YP	1	SCREW, 3/8-24 x 1-3/4" Hex Head Cap, GR 5
10	7032030SM	2	WASHER, 13/32 x 1-1/4" Flat
11	7046155YP	1	LEVER, Height of Cut
12	7090289SM	1	NUT, 3/8-24 Hex Center Lock
13	7046159YP	1	SPRING, Lever
14	7012068YP	2	RING, Rear Lift Arm (Blue)
15	7031855YP	1	GUIDE, Belt
16	7046163YP	2	SPRING, Assist
17	7031838YP	1	BRACE, Top
18	7016122YP	1	ROD, Leveling (3/4-24 thread)
19	7090361YP	1	SCREW, 5/16-18 x 5/8" Hex Washer Self-Tap
20	7058969YP	1	ASSEMBLY, Clutch Plate
21	7043848YP	1	RAIL, Deck Lift, Right Hand
22	7073269YP	1	RAIL, Deck Lift, Left Hand
23	7046157YP	1	DETENT, Height Adjust
24	7090324SM	2	SCREW, 3/8-16 x 1" Hex Washer Self-Tap
25	7046217YP	1	SPACER, Detent
26	7091198SM	3	SCREW, 3/8-16 x 5/8" Hex Washer Self-Tap
27	7026420YP	1	GRIP, Height Adjustment Lever
28	7012067YP	2	RING, Front Lift Arm (Red)
29	7032997YP	1	ARM, Front Lift
30	7058041YP	1	WELDMENT, Front Lift Arm
31	7090365YP	1	PIN, 1/8 x 3/4" Cotter
32	7022717YP	1	ROD, Deck Support (Front Lift Arm to Front End)
33	7017847YP	1	RING, .438 External Retaining
34	7090858YP	2	SCREW, 5/16-18 x 1/2" Hex Washer Self-Tap
35	7071920YP	2	SPACER, Deck Lift
36	7092051YP	1	BOLT, #10-24 x 1" Flat Head Square Neck
37	7091290SM	1	NUT, #10-24 Hex Nyloc
38	7032243YP	1	ANCHOR
39	7090233YP	2	SCREW, 5/16-24 x 3/4" Hex Head Cap, GR 5
40	7090391SM	2	WASHER, 5/16" Internal Tooth Lock

Footnotes

NOTE: Unless noted otherwise, use the standard hardware torque specification chart.

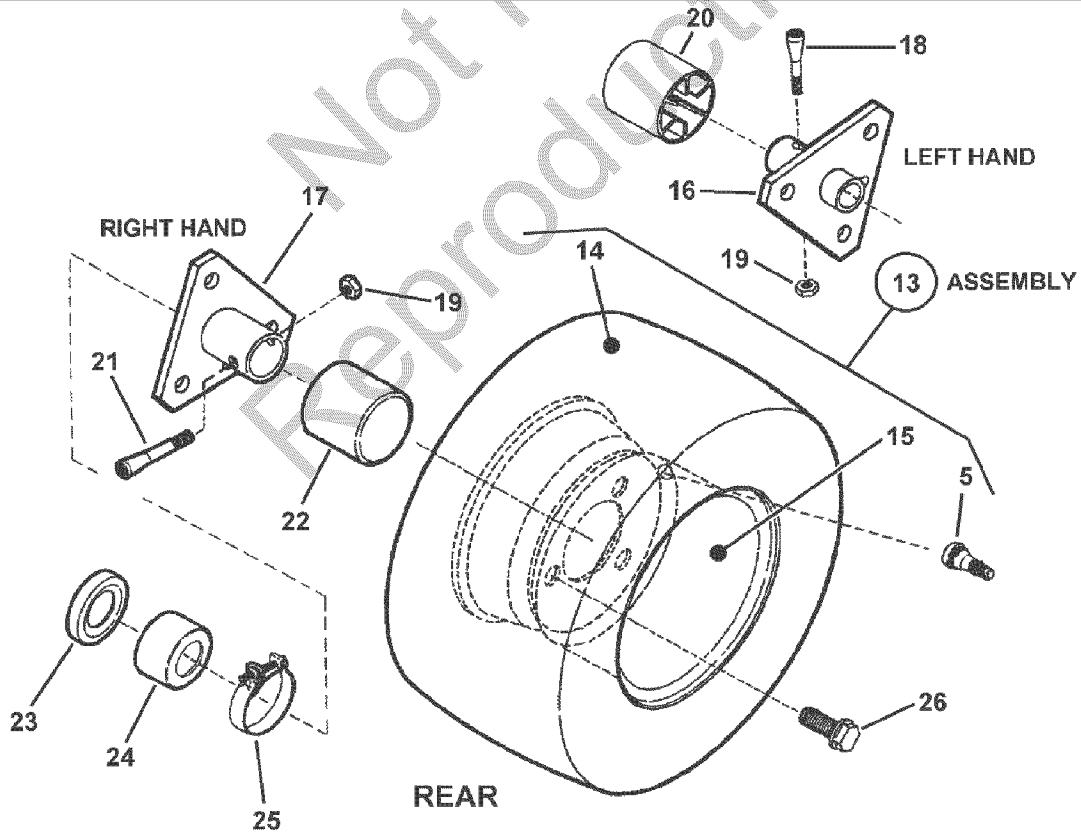
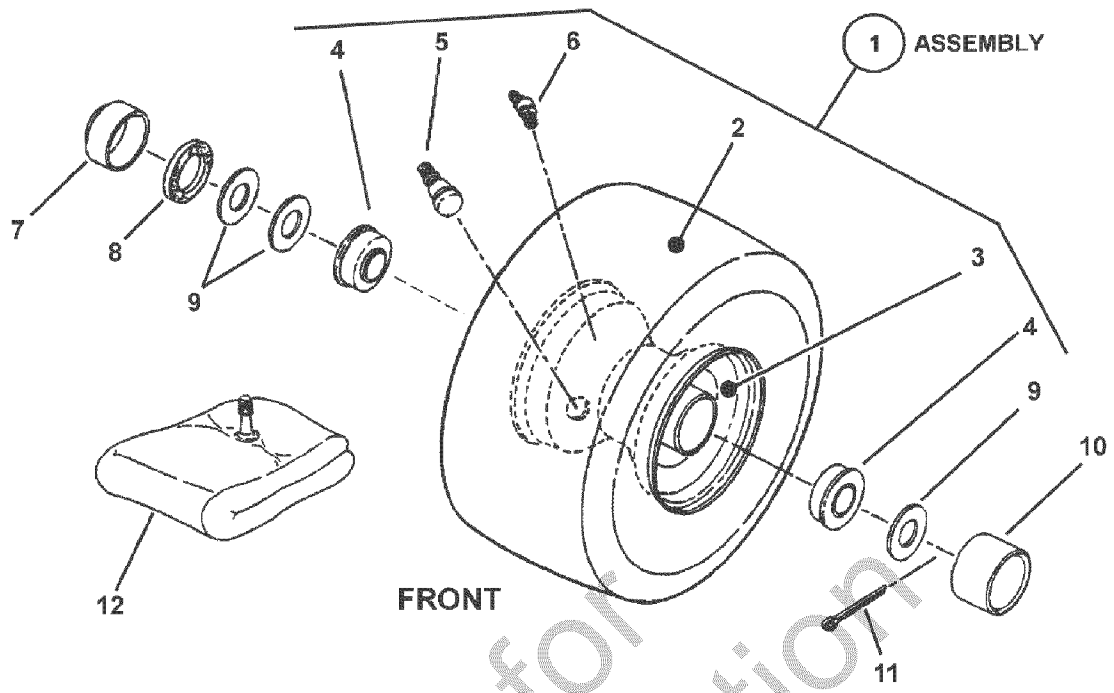

Wheels - Front & Rear**CRAFTSMAN 28" 107.280340**

REF NO	PART NO.	QTY.	DESCRIPTION
1	7058943YP	2	ASSEMBLY, Front Tire & Rim Complete (Includes Items 2, 3, 4, 5 & 6)
2	7073563YP	1	TIRE, 11 x 4.00-4 (Kenda)
3	7017146YP	1	RIM (For 4.10/3.50 x 4 Tire)
4	7011807YP	2	BALL BEARING, Flange (3/4" I.D.)
5	7012234SM	1	VALVE STEM, Snap In
6	7014669YP	1	LUBE Fitting
7	7031038YP	1	CAP, Dust
8	7011032YP	1	FELT SEAL
9	7010935SM	3	WASHER, .77 x 1.13 x .06 Flat
10	7103979YP	1	HUB CAP
11	7091516SM	1	COTTER PIN, 5/32 x 1"
12	7010821YP	1	TUBE, Inner (For 4.10/3.50 x 4 Tire)
13	7058951YP	2	ASSEMBLY, Rear Tire & Rim (28", 30", 33" Models) (Includes Items 5, 14 & 15)
14	7073584YP	1	TIRE, 16-6.50 x 8
15	7017147YP	1	RIM, Extra Wide (For 16/7.50 x 8 Tire) (33" Models)
16	7040434YP	1	HUB, Rear Wheel LH, 3 Hole 3/4" ID
17	7040433YP	1	HUB, Rear Wheel RH, 3 Hole 1" ID
18	7011035YP	1	AXLE BOLT, Left Hand (5/16-24 x 1-5/8" Tapered)
19	7011201YP	1	NUT, Wheel Bolt, 5/16-24 Hex Center Lock
20	7103980YP	1	CAP, Hub, L. H. (Long Axle)
21	7011013YP	1	WHEEL BOLT, Right Hand (5/16-24 x 2" Tapered)
22	7103981YP	1	CAP, Hub
23	7011817YP	1	SEAL, 1.22" ID x 1.875" OD CAP, Seal 1.0" ID x 1.67" OD
24	7031732YP	1	CAP, Seal 1.0" ID x 1.67" OD, Right Hand
25	7012332YP	1	CLAMP, Right Hand 2"
26	7091502YP	3	BOLT, 1/2-20 x 3/4" Lug, GR 5

Footnotes

NOTE: Unless noted otherwise, use the standard hardware torque specification chart.

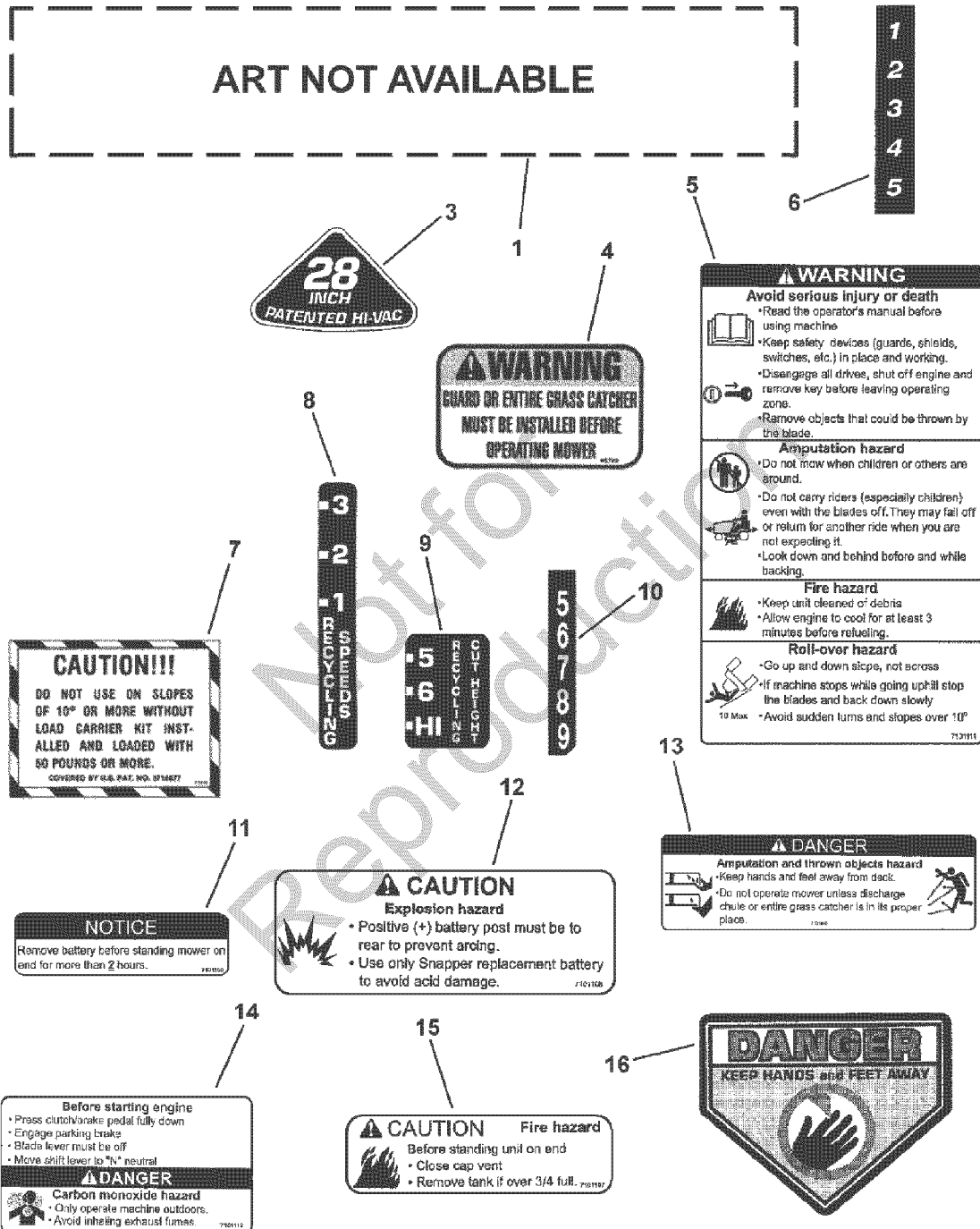

Decals**CRAFTSMAN 28" 107.280340**

REF NO	PART NO.	QTY.	DESCRIPTION
1	7103999YP	1	DECAL, Craftsman
3	7023996YP	1	DECAL, 28 Inch (Hi-Vac)
4	7046720SM	1	DECAL, Chute/Deflector Warning
5	7101111YP	1	DECAL, Warning, Safety Panel
6	7046218YP	1	DECAL, Height of Cut
7	7011910YP	1	DECAL, Grass Catcher
8	7017176SM	1	DECAL, Recy Ground Speed
9	7017328YP	1	DECAL, Recy Height-Of-Cut
10	7022325YP	1	DECAL, Height-Of-Cut
11	7101109YP	1	DECAL, Remove Battery
12	7101108YP	1	DECAL, Caution, Battery
13	7101110YP	1	DECAL, Danger, Deck
14	7101112YP	1	DECAL, Danger, Safety Panel
15	7101107YP	1	DECAL, Caution, Fuel
16	7013010SM	1	DECAL, Danger, Cut Finger

Not for
Reproduction

Footnotes

NOTE: Unless noted otherwise,
use the standard hardware torque
specification chart.

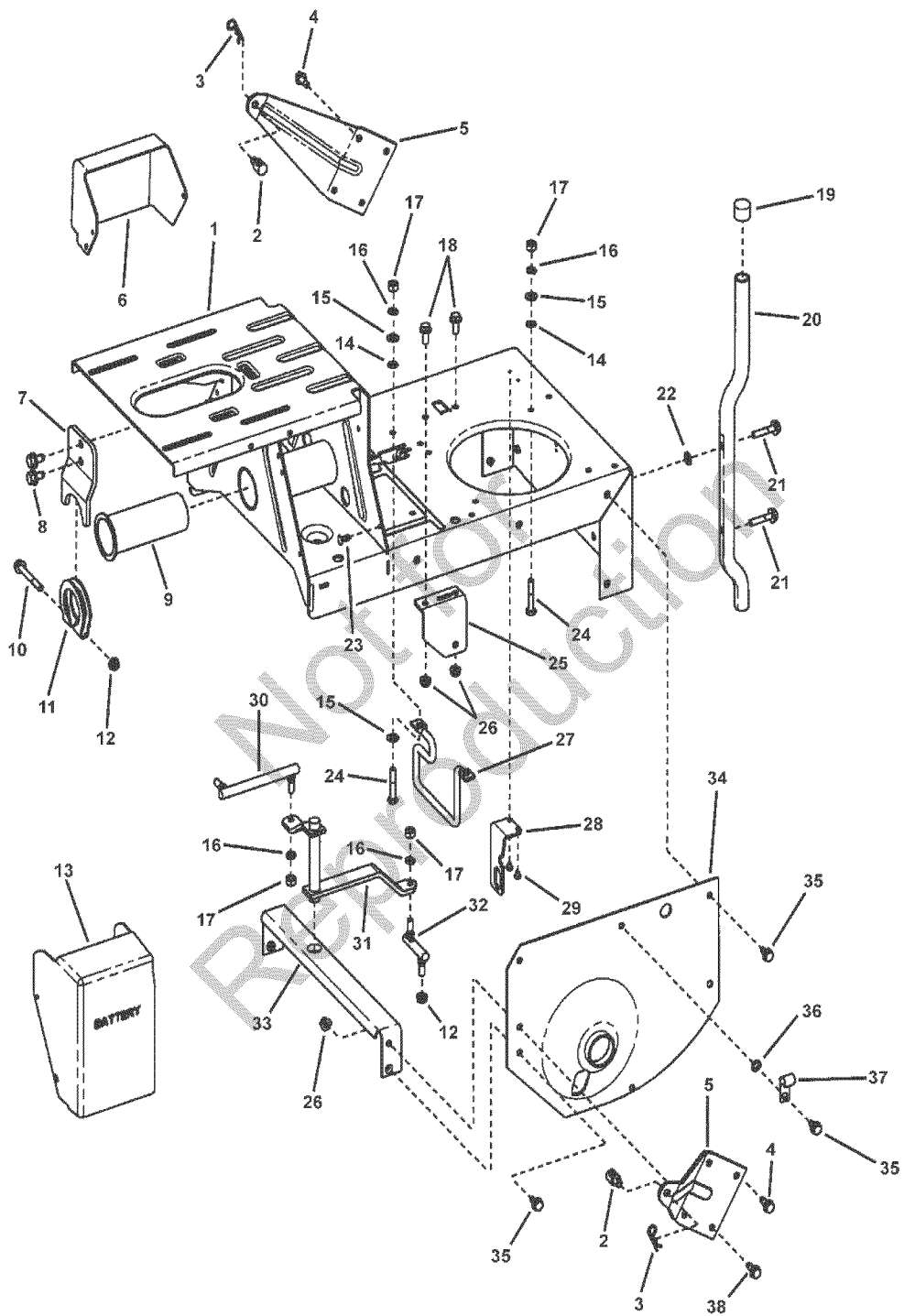

REF NO	PART NO.	QTY.	DESCRIPTION
1	7053697YP	1	WELDMENT, Main Case (Standard)
2	7028200SM	2	SWIVEL, Adjustable
3	7091503SM	2	HAIR PIN, 3/32 x 1-1/2"
4	7090793YP	4	SCREW, 5/16-18 x 3/4" Hex Washer Self-Tap
5	7034299YP	2	WING, Rear
6	7073268YP	1	COVER, Solenoid
7	7074210YP	1	BRACKET, Belt Adjuster
8	7091198SM	2	SCREW, 3/8-16 x 5/8" Hex Washer Self-Tap
9	7074650YP	1	BUSHING, Pivot
10	7090358YP	1	SCREW, 5/16-24 x 2-1/2" Hex Head Cap, GR 5
11	7031100YP	1	TUBE CLAMP
12	7010969YP	2	NUT, 5/16-24 Flange Lock (Large)
13	7028990YP	1	COVER, Battery
14	7011791SM	4	RETAINER, 5/16" Bolt
15	7090188SM	4	WASHER, 5/16" Flat
16	7091315SM	7	WASHER, .32 x .58 x .08 Split Lock
17	7091297SM	7	NUT, 5/16-24 Hex, GR 5
18	7090595SM	2	BOLT, 5/16-18 x 3/4" Hex Flange Lock, GR 5
19	7010153YP	2	CAP, Bumper
20	7030798ZYP	2	BUMPER, Rear
21	7091506YP	4	SCREW, 5/16-18 x 1-1/2" Hex Washer Self-Tap
22	7090188SM	2	WASHER, 11/32" Flat
23	7091272YP	7	FASTENER, 1/4" Ratchet
24	7091513YP	4	SCREW, 5/16-24 x 1-3/4" Hex Head Cap, GR 5
25	7047189YP	1	BRACKET, Drive Support
26	7090585MA	6	NUT, 5/16-18 Hex Flange Lock, GR 5
27	7017653YP	1	BELT GUIDE, 25, 26, 28, 41" (5.74" Bolt Pattern, 4.74" Belt Gap)
28	7073735YP	1	BRACKET, Switch
29	7090981YP	2	SCREW, #10-32 x 1/4" Hex Washer Self-Tap
30	7023676YP	1	SHIFT LINK, Long (5/16-24 both ends)
31	7041384YP	1	WELDMENT, Shift Arm
32	7011018YP	1	SHIFT LINK, Short (5/16-24 thread)
33	7033799YP	1	CROSS BRACE
34	7037285YP	1	FENDER, Left Hand (1.628" I. D. Hole)
35	7090361YP	14	SCREW, 5/16-18 x 5/8" Hex Washer Self-Tap
36	7090391SM	1	WASHER, 5/16" Internal Tooth Lock
37	7012652YP	1	CLIP, Wire
38	7090206YP	1	SCREW, 5/16-18 x 3/4" Hex Head Cap, GR 5

Footnotes

NOTE: Unless noted otherwise,
use the standard hardware torque
specification chart.

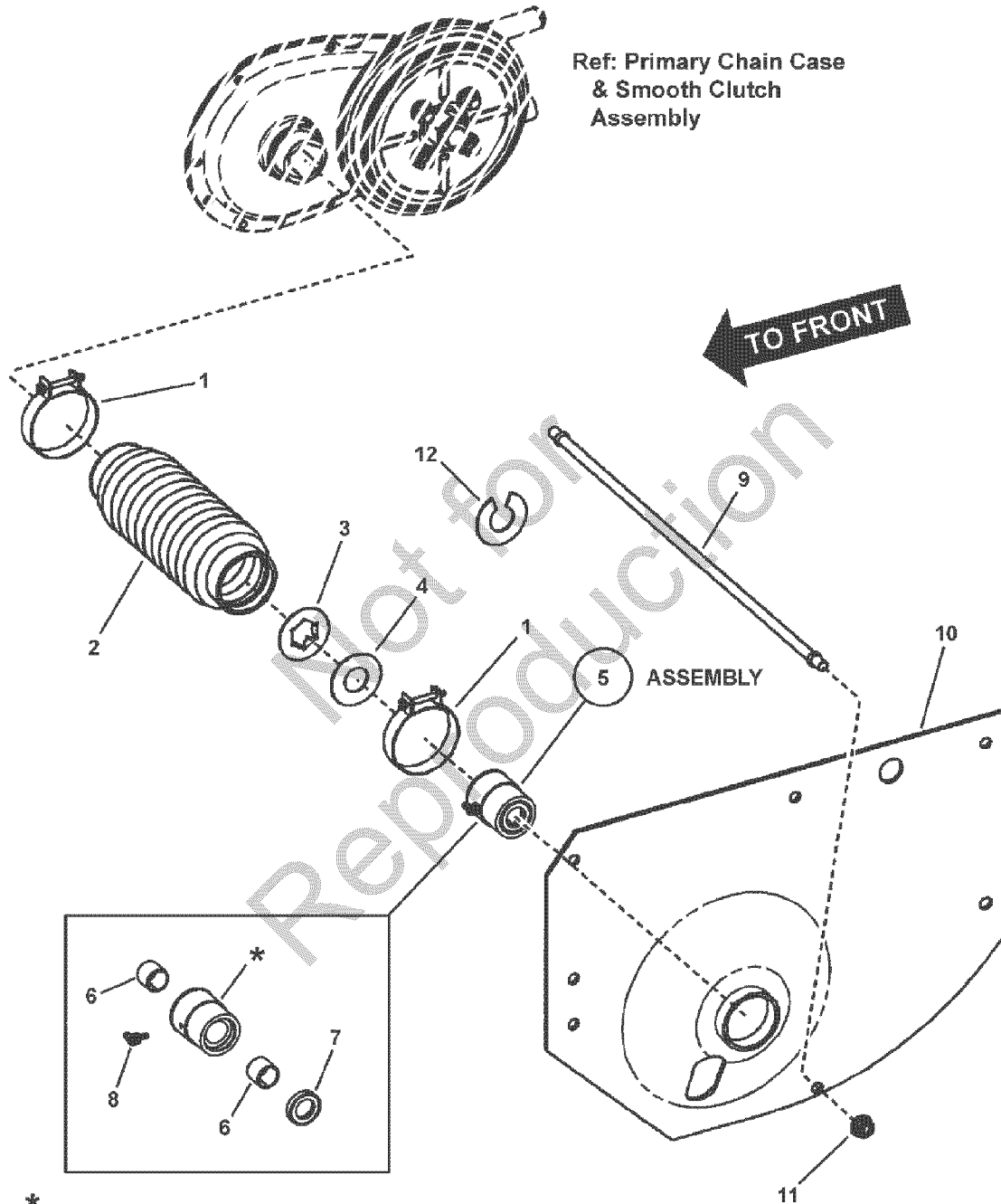

* Not available separately,
order Ref. 5 Separately

Left Hand Fender & Bearing**CRAFTSMAN 28" 107.280340**

REF NO	PART NO.	QTY.	DESCRIPTION
1	7012332YP	2	BOOT CLAMP, 2"
2	7075115YP	1	BOOT, Rear Axle, Thick Flange
3	7011072YP	1	WASHER, Thrust
4	7011071YP	1	THRUST WASHER
5	7052827YP	1	ASSEMBLY, DX Bearing (Includes Ref. Nos. 6, 7 & 8)
6	7074182YP	2	BEARING, DX
7	7074500YP	1	SEAL, Axle (Dust/Grease)
8	7075848YP	1	FITTING, Lube, 45 Degree, 3/16" w/Hex (long shank)
9	7011070YP	1	TIE ROD (5/16-24 thread- both ends)
10	7037285YP	1	FENDER, Left Hand (1.628" I. D. Hole)
11	7010969YP	1	NUT, 5/16-24 Flange Lock (Large)
12	7012271YP	1	WASHER, Shim or quantity as required

Not for
Reproduction

Footnotes

Primary Chain Case & Smooth Clutch

CRAFTSMAN 28" 107.280340

NOTE: Unless noted otherwise,
use the standard hardware torque
specification chart.

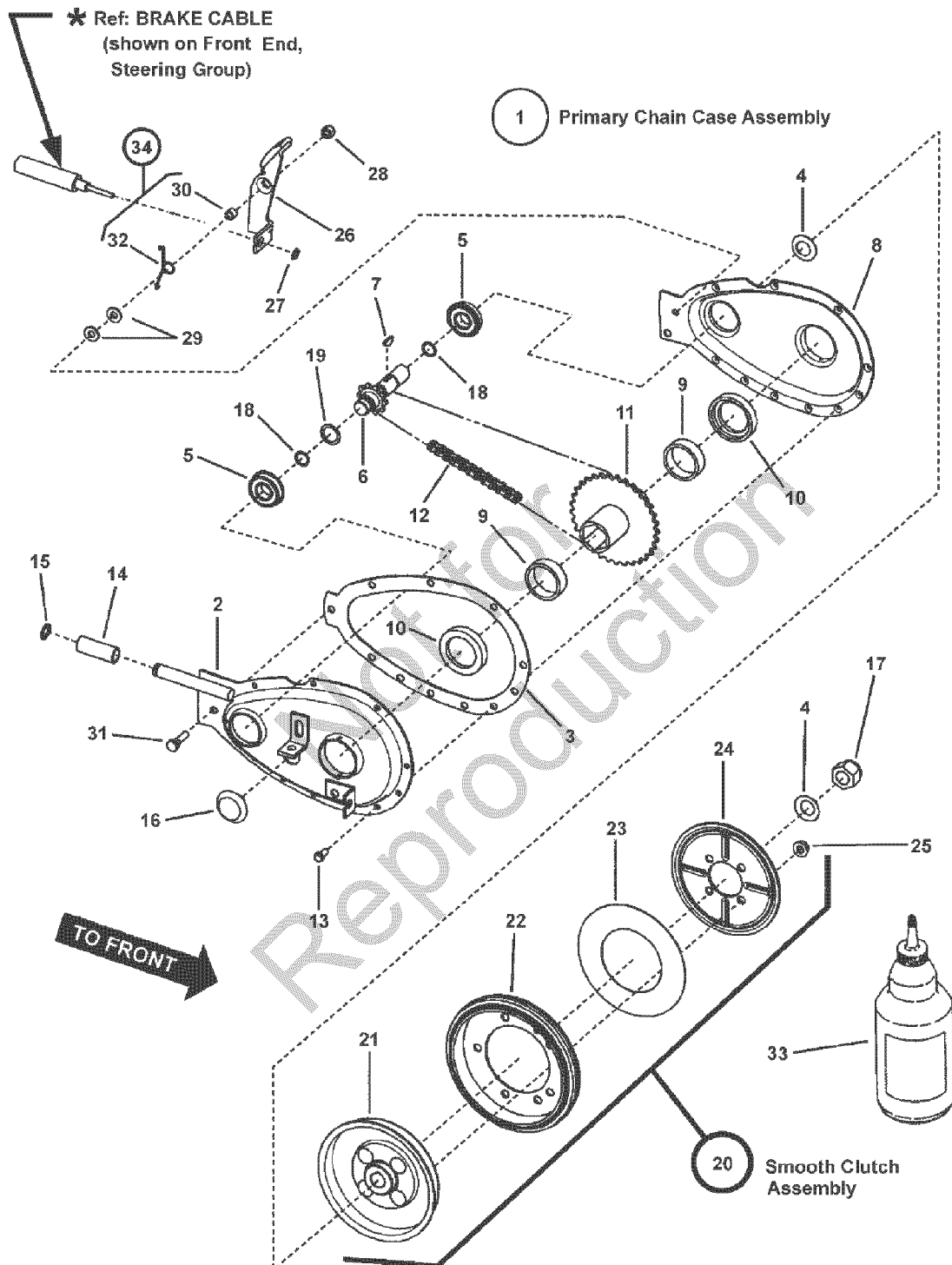

Primary Chain Case & Smooth Clutch**CRAFTSMAN 28" 107.280340**

REF NO	PART NO.	QTY.	DESCRIPTION
1	7052683YP	1	ASSEMBLY, Primary Chain Case (Includes Ref. Nos. 6 through 12)
2	7041136YP	1	WELDMENT, Primary Chain Case Half, Right Hand
3	7028761YP	1	GASKET, Primary Chain Case
4	7011121SM	2	WASHER, 5/8" Belleville
5	7010756YP	2	BEARING, .625 x 1.37 x .435
6	7018963YP	1	WELDMENT, Sprocket & Shaft
7	7010614YP	1	KEY, #5 Woodruff
8	7039778YP	1	PRIMARY CHAIN CASE HALF, Left Hand
9	7010942YP	2	BEARING, Needle 1.355" ID x 1.6245" OD x .5" Wide
10	7011086YP	2	THRUST WASHER, Nylon
11	7040355YP	1	WELDMENT, Hub & Sprocket
12	7010941YP	1	CHAIN, 46 Pitch (#35 Endless)
13	7090307YP	10	SCREW, 10-24 x 1/2" Hex Washer Self-Tap
14	7022785YP	1	ROLLER, 1-3/8 Long
15	7010776YP	1	RING, 1/2" External Retaining (Heavy Duty)
16	7011024YP	1	PLUG, 3/4" Cup Insert
17	7091505YP	1	NUT, 5/8-18 Hex Nyloc
18	7019260YP	2	O-RING, 1/2 x 5/8"
19	7027981YP	1	WASHER, Shim .625 x .875
20	7053114YP	1	ASSEMBLY, Smooth Clutch, non-asbestos (Includes Ref. Nos. 21 through 25)
21	7059443YP	1	HUB, Driven Disc Assembly
22	7053103YP	1	DISC, Driven (rubber tire bonded to rim)
23	7014523YP	1	THRUST WASHER
24	7032331YP	1	PLATE, Drive Disc
25	7092081YP	4	NUT, 5/16-24 Hex Flange Lock
26	7052497YP	1	ASSEMBLY, Brake Lever (Includes brake pad & rivet)
27	7012313SM	1	RING, 3/8" External Retaining
28	7090303YP	1	NUT, 1/4-28 Hex Top Lock
29	7091294SM	2	WASHER, .28 x .63 x .06 Flat, GR 5
30	7072593YP	1	SPACER, Brake Arm Pivot (.418/.403 long)
31	7091504YP	1	SCREW, 1/4-28 x 1" Hex Head Cap, (Washer Face) GR 5
32	7072406YP	1	SPRING, Torsional Brake Return
33	7061017YP		GREASE, Transmission (Use 2 oz. Maximum)
34	7061197YP	1	KIT, Brake Return Replacement (Includes Ref. Nos. 30 & 32)

Footnotes

NOTE: Unless noted otherwise,
use the standard hardware torque
specification chart.

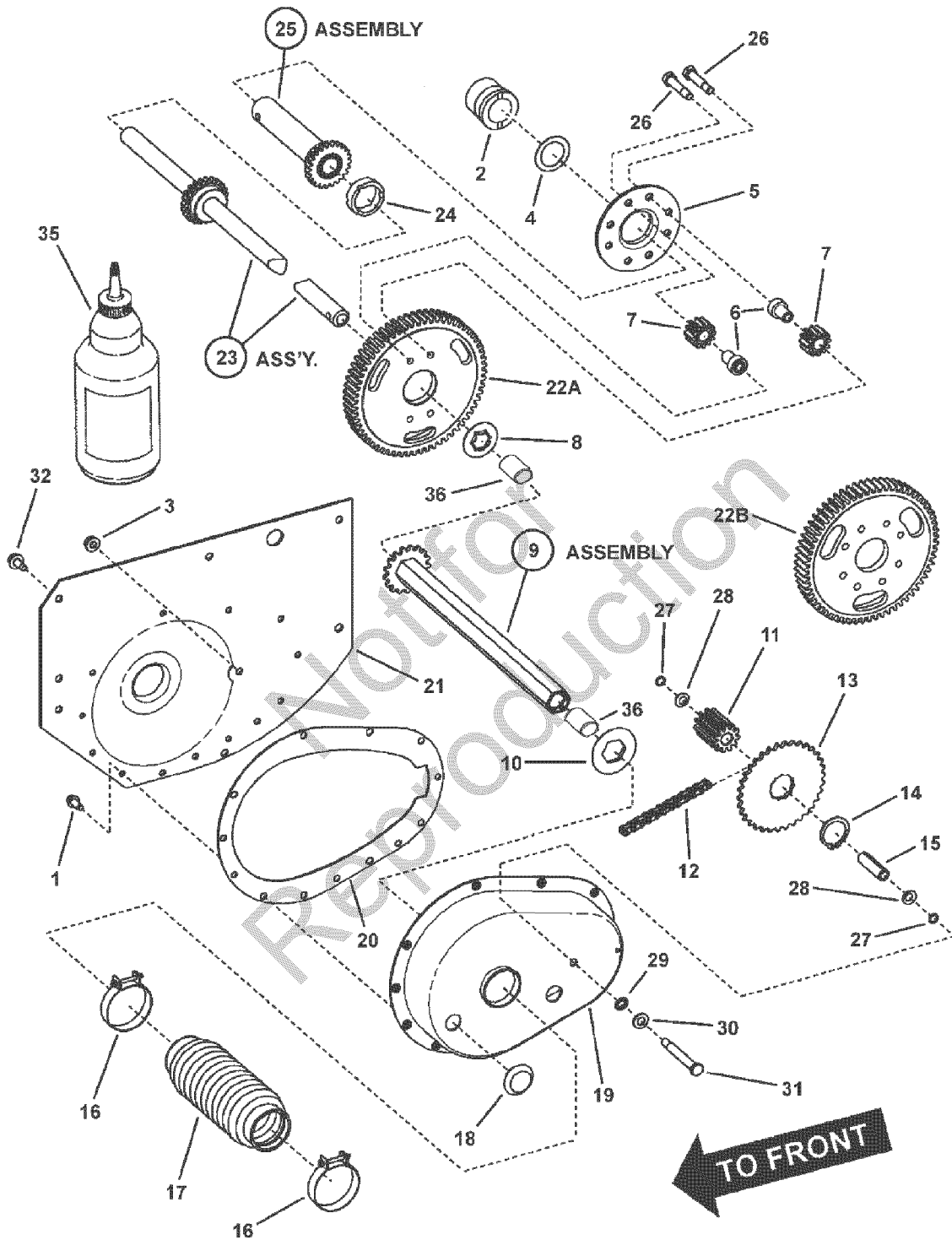

REF NO	PART NO.	QTY.	DESCRIPTION
1	7090362YP	13	SCREW, 1/4-20 x 5/8" Hex Washer Head Self-Tap
2	7012296YP	1	BEARING, Axle (R. H. Fender)
2	7054372YP	1	BEARING-DX, Axle (R. H. Fender) includes 1-1/8" I.D. (DX) bearing
3	7010969YP	1	NUT, 5/16-24 Flange Lock (Large)
4	7031079YP	1	WASHER, Thrust
5	7038067YP	1	PLATE, Differential Note: 4 holes offset - align properly to prevent binding.
6	7022115YP	4, 8	SPACER, Pinion
7	7021127YP	4, 8	GEAR, Differential Pinion (12T 12P)
8	7011072YP	1	WASHER, Thrust
9	7051584YP	1	ASSEMBLY, Drive Hex Tube (Includes Ref. Nos. 10 & 36)
10	7010988YP	1	WASHER, Nylon
11	7200128YP	1	GEAR, 11 Tooth, 10 Pitch
12	7010941YP	1	CHAIN, 46 Pitch (#35 Endless)
13	7021129YP	1	SPROCKET, 34T, 3/8P
14	7010965YP	1	RING, 1-3/16" External Retaining
15	7021128YP	1	SPACER, Differential Case
16	7012332YP	2	BOOT CLAMP, 2"
17	7075115YP	1	BOOT, Oil Seal (Short Axle)
18	7011024YP	1	PLUG, 1/2" Cup Insert
19	7037279YP	1	CASE, Transmission
20	7028762YP	1	GASKET, Transmission Case
21	7037280YP	1	FENDER, Right Hand (1.62" Dia. Hole)
22A	7021158YP	1	GEAR, 63 Tooth 10 Pitch (4 Hole)
22B	7027644YP	1	GEAR, 63 Tooth 10 Pitch (8 Hole)
23	7047763YP	1	KIT, Long Axle Structure (Includes Ref. No. 24)
24	7074431YP	1	SPACER, Differential Case
25	7057398YP	1	ASSEMBLY, Short Axle, 23T (Includes Gear)
26	7012333YP	4, 8	BOLT, 5/16-24 x 1-5/8" Hex Special Lock (Vibresist)
27	7011156YP	2	5/16" O-RING
28	7011782YP	2	WASHER, 5/16" Belleville
29	7090395YP	1	WASHER, 5/16" External Tooth Lock
30	7090188SM	1	WASHER, .34 x .69 x .08 Flat
31	7011042YP	1	SCREW, 5/16-24 x 2-5/8" Hex Head Cap
32	7090361YP	11	SCREW, 5/16-18 x 5/8" Hex Washer Self-Tap
35	7061017YP		GREASE, Transmission (24 oz. Required)
36	7015140YP	2	BEARING, DX
--	7060411YP	1	KIT, Differential (4 Pinion)
--	7060662YP	1	KIT, Differential (8 Pinion w/DX Bearing)
--	7060412YP	1	KIT, Long & Short Axle (Includes items 23, 24, & 25)

Footnotes

NOTE: Unless noted otherwise,
use the standard hardware torque
specification chart.

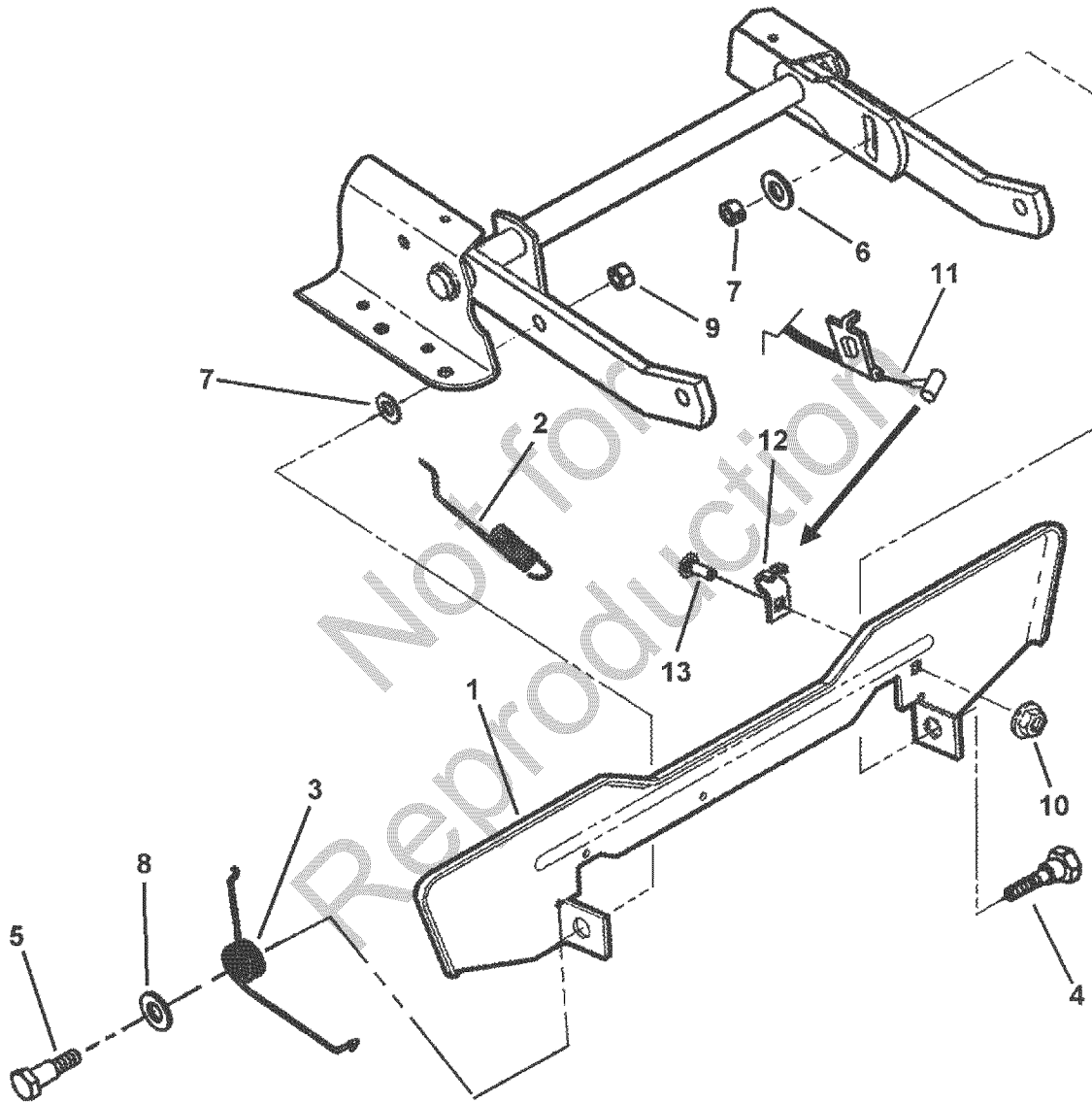

Blade Stop Pedals**CRAFTSMAN 28" 107.280340**

REF NO	PART NO.	QTY.	DESCRIPTION
1	7073267YP	1	FOOT PEDAL, Blade Stop Control
2	7074649YP	1	SPRING, Latching (.072 dia.)
3	7015448YP	1	SPRING, Pedal
4	7015495YP	1	SHOULDER BOLT, 3/8-24 w/Nylon Patch, GR 5
5	7015446YP	1	SHOULDER BOLT, 3/8-24 x 9/16"
6	7032030SM	1	WASHER, Flat 13/32" ID x 1.25" x 1/8" Thick ZP
7	7090155YP	1	NUT, 3/8-24 Hex, GR B
8	7090250YP	2	WASHER, 1/2" Flat SAE
9	7090289SM	1	NUT, 3/8-24 Hex Center Lock
10	7091584SM	1	NUT, 1/4-20 Hex Flange Lock, GR 5
11	7073216YP	1	CABLE ASSEMBLY, No Reverse in Mow
12	7073217YP	1	CLIP, Cable
13	7091776YP	1	BOLT, 1/4-20 x 3/4" Square Neck Carriage, GR 5

Not for
Reproduction

Footnotes

NOTE: Unless noted otherwise,
use the standard hardware torque
specification chart.

1 ASSEMBLY

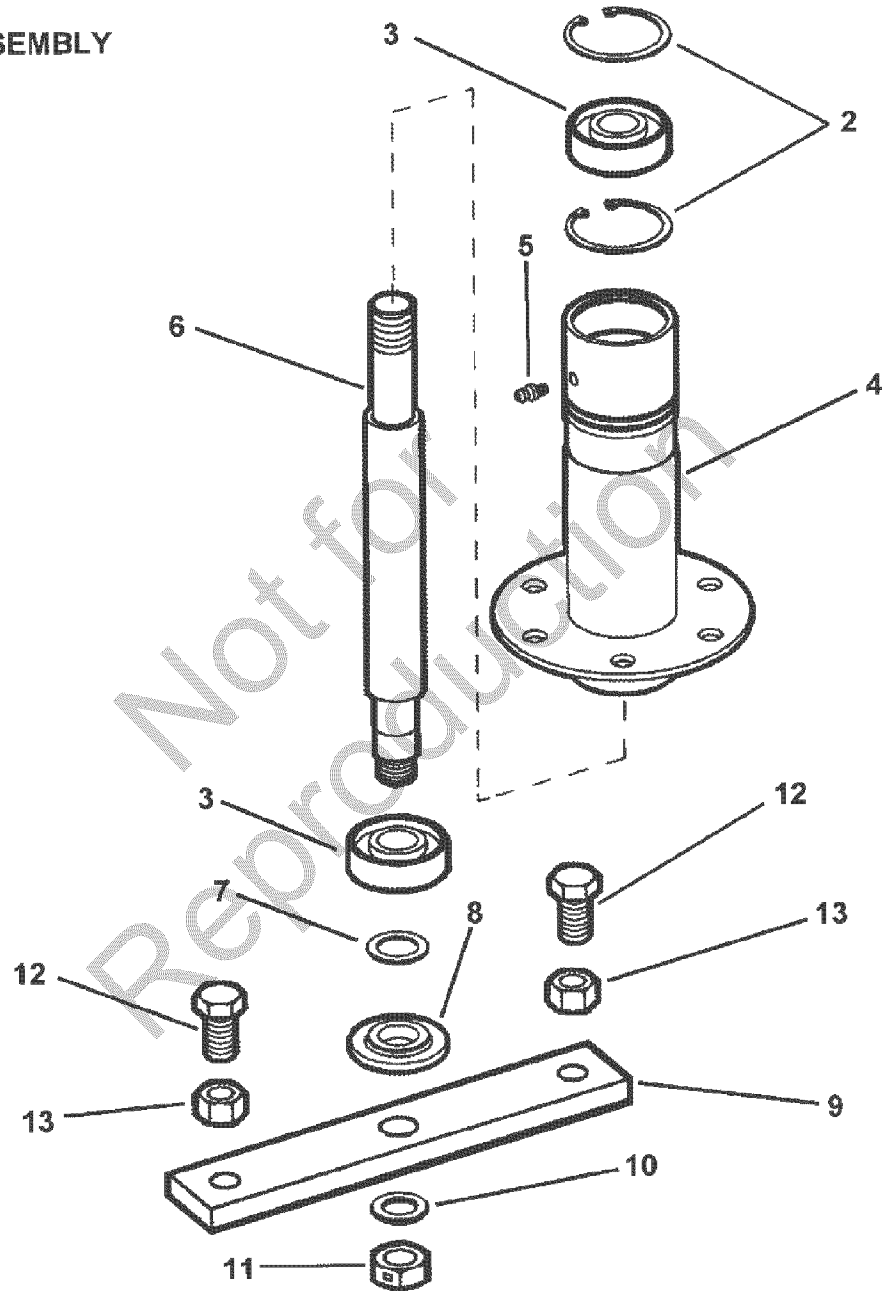

Spindle Assembly**CRAFTSMAN 28" 107.280340**

REF NO	PART NO.	QTY.	DESCRIPTION
1	7058049YP	1	ASSEMBLY, Spindle (Includes Ref. Nos. 2 through 11)
2	7012491SM	2	RING, 1.85" Internal Retaining
3	7013313SM	2	BEARING, Spindle
4	7050696YP	1	ASSEMBLY, Spindle Housing (Includes Ref. No. 5)
5	7010817SM	1	LUBE FITTING, 3/16" Press-In
6	7044785YP	1	SPINDLE, Rider (10.327" overall length)
7	7010935SM	1	WASHER, .77 x 1.13 x .06 Flat
8	7014407SM	1	WASHER, Spindle
9	7031184YP	1	HOLDER, Blade
10	7044782YP	1	SPACER, Blade Centering
11	7090356YP	1	NUT, 5/8-18 Hex Center Lock Jam
12	7090491YP	2	SCREW, 1/2-20 x 1-1/4" Hex Head Cap, GR 5
13	7091939YP	2	NUT, 1/2-20 Hex, GR 5 or B

Not for
reproduction

Footnotes

NOTE: Unless noted otherwise, use the standard hardware torque specification chart.

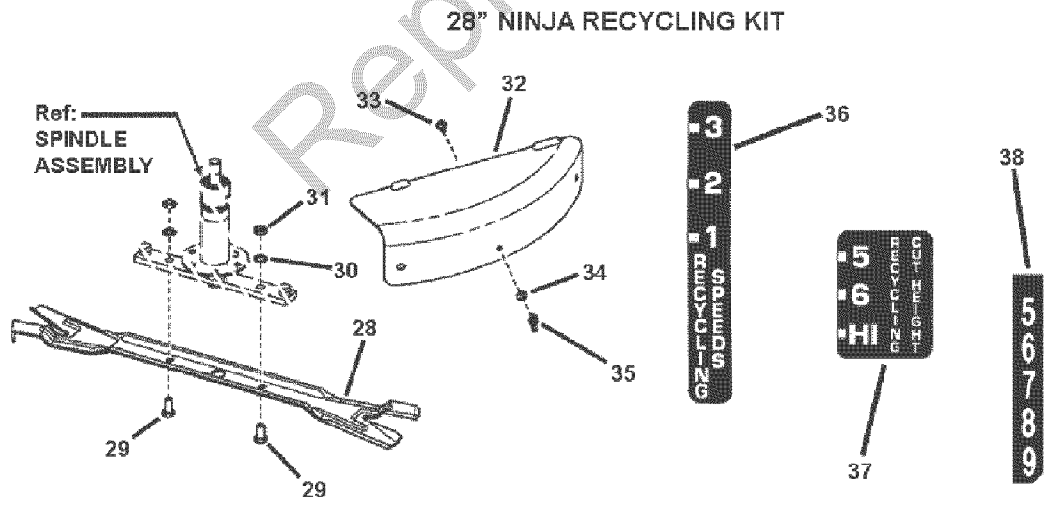
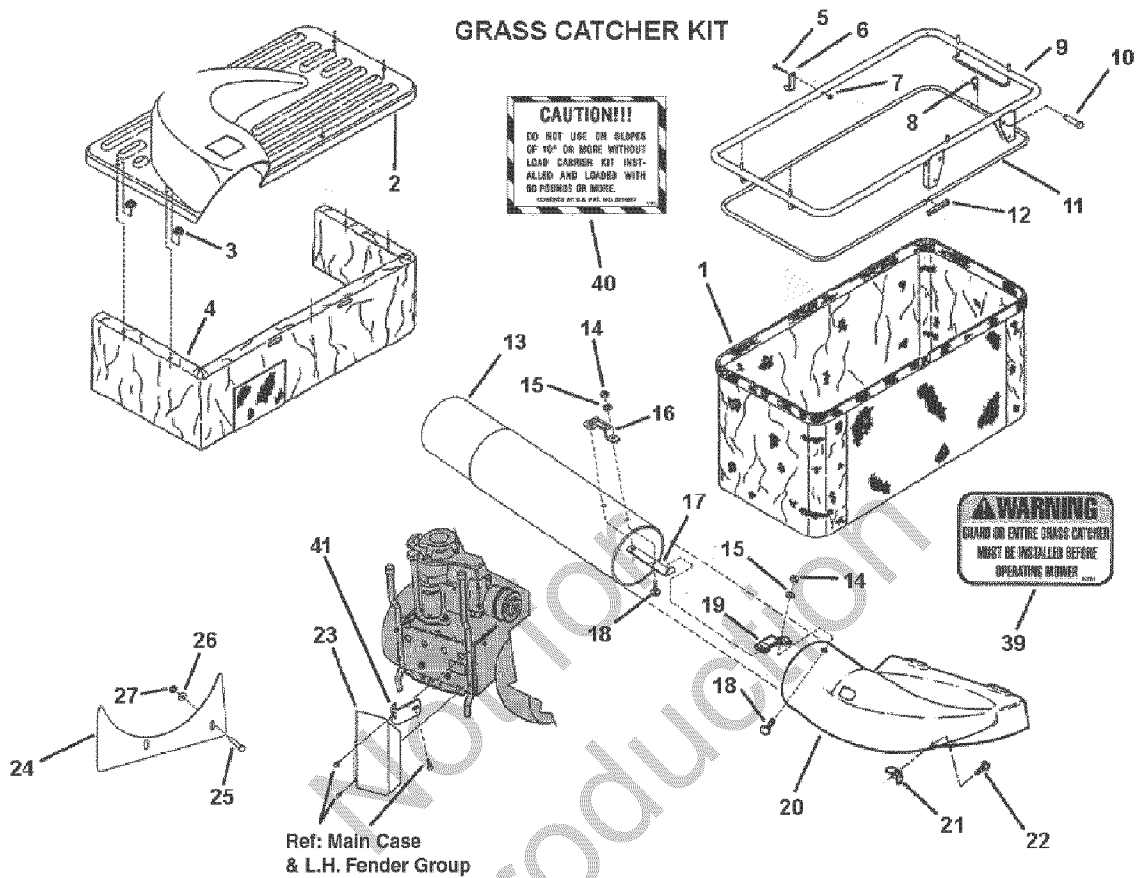

Accessories**CRAFTSMAN 28" 107.280340**

REF NO	PART NO.	QTY.	DESCRIPTION
--	7600101YP	1	KIT, Single Bag Grass Catcher, 28" (Includes Ref. Nos. 1 through 27)
1	7019251YP	1	GRASS BAG, Single, Zipperless
2	7104012YP	1	TOP, Grass Container, No Graphics
3	7029840YP	5	WASHER, 5/16 Faceted
4	7016108YP	1	DUST SKIRT
5	7090532YP	1	SCREW, #10-32 x 1-3/8" Hex Head Machine
6	7031725YP	1	LATCH, Grass Catcher Top
7	7090376YP	1	NUT, #10-32 Hex Nyloc
8	7091503SM	2	PIN, 3/32 x 1-1/2" Hair, YZ
9	7047973YP	1	FRAME STRUCTURE
10	7029841YP	2	PIN, 5/16 x 1-11/16" Clevis
11	7037758YP	1	ROD, Bag
12	7012556YP	1	CONNECTOR, Bag Rod
13	7014517YP	1	GRASS TUBE, 28-33
14	7091576SM	3	NUT, 1/4-20 Hex, YZ
15	7091314YP	3	WASHER, 1/4" Internal Tooth Lock, YZ
16	7037745YP	1	HANDLE, Tube
17	7031952YP	1	BASE, Handle
18	7091530SM	3	BOLT, 1/4-20 x 3/4" Round Head Short Square Neck Carriage, YZ
19	7031951YP	1	LATCH, Tube
20	7019912YP	1	ADAPTER, 28" Deck
21	7091537YP	1	WING LOCKNUT, 5/16-18, YZ
22	7091303YP	1	BOLT, 5/16-18 x 1" Round Head Short Square Neck, GR 5
23	7071677YP	1	MUFFLER GUARD, Grass Catcher
24	7063287YP	1	SHIELD, Grass Catcher Debris
25	7090909YP	2	BOLT, 1/4-20 x 1-1/2" Hex Head
26	7091294SM	2	WASHER, 1/4" Flat
27	7091705SM	2	NUT, 1/4-20 Hex top Lock
--	7600100YP	1	KIT, Ninja Recycling, 28" Deck (Includes Ref. Nos. 28 through 38)
28	7104083YP	1	BLADE, Ninja, 28"
29	7090392YP	2	SCREW, 1/2-20 x 1" Hex Head Cap, GR 5
30	7090509YP	2	WASHER, 1/2" Internal Tooth Lock
31	7090559YP	2	NUT, 1/2-20 Hex Jam, GR 5 or B
32	7016983YP	1	COVER, 28" Mulcher
33	7090001YP	3	BOLT, 5/16-18 x 3/4" Round Head Short Square Neck Carriage, GR 5
34	7090188SM	3	WASHER, 5/16" Flat
35	7090492YP	3	NUT, 5/16-18 Wing
36	7017176SM	1	DECAL, Recy Ground Speed
37	7017328YP	1	DECAL, Recy Height-Of-Cut
38	7022325YP	1	DECAL, Height-Of-Cut
39	7046720SM	1	DECAL, Chute/Deflector Warning
40	7011910YP	1	DECAL, Grass Catcher
41	7042716YP	1	BRACKET, Bumper Reinforcement

Footnotes

219977-0130-B1

48 SHORT BLOCK

1058 OPERATOR'S MANUAL

1329 REPLACEMENT ENGINE

1330 REPAIR MANUAL

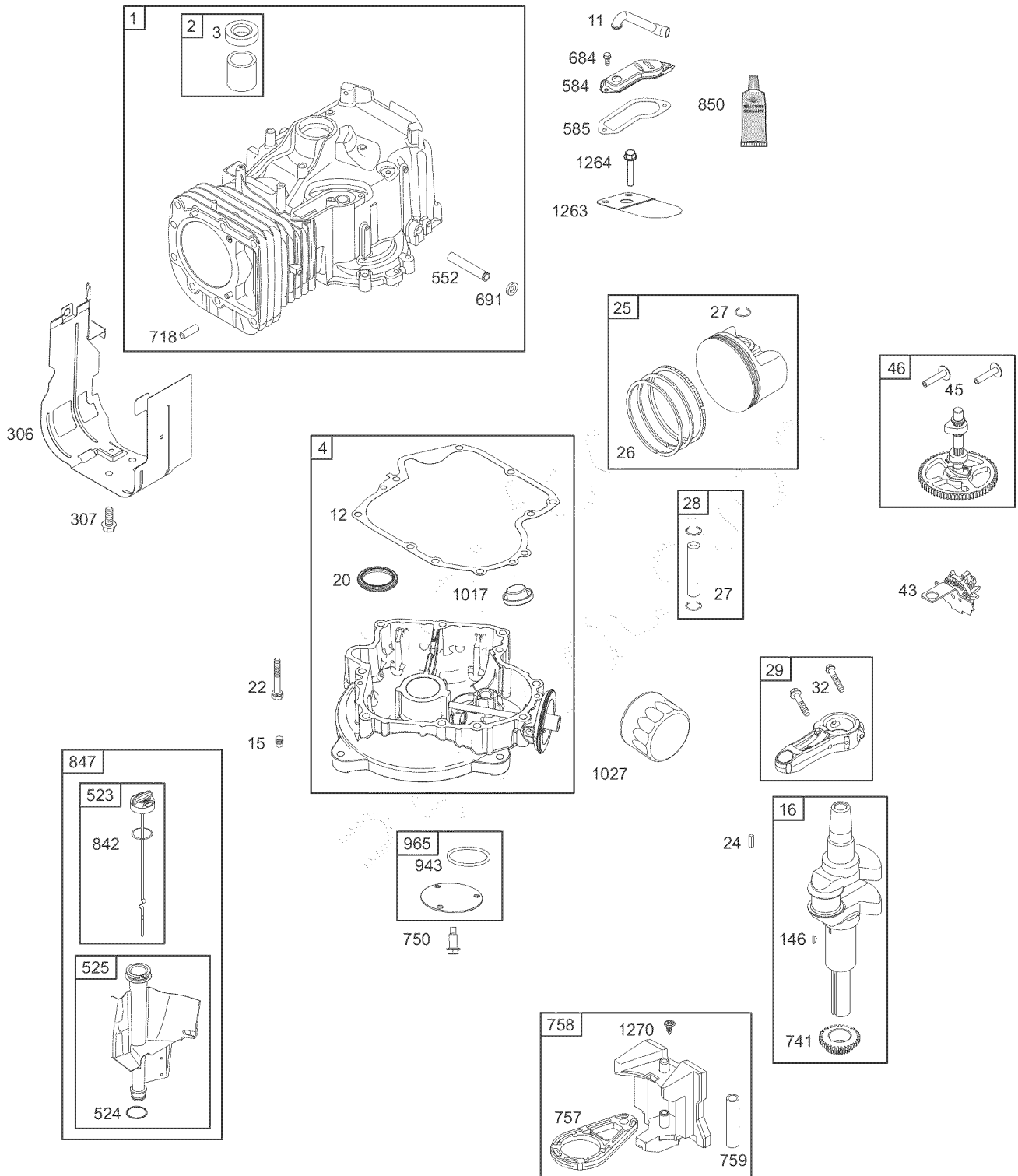

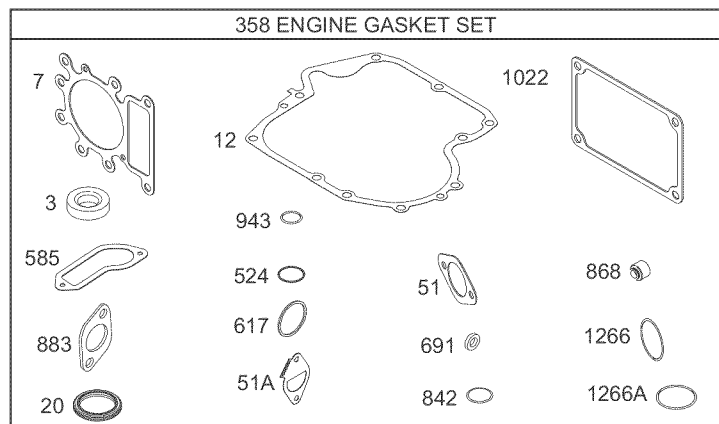
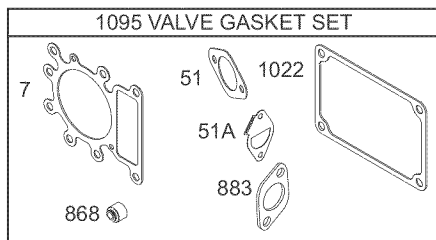
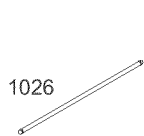
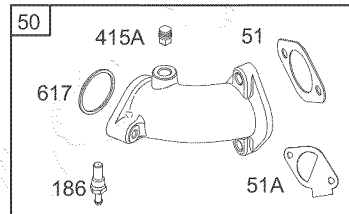
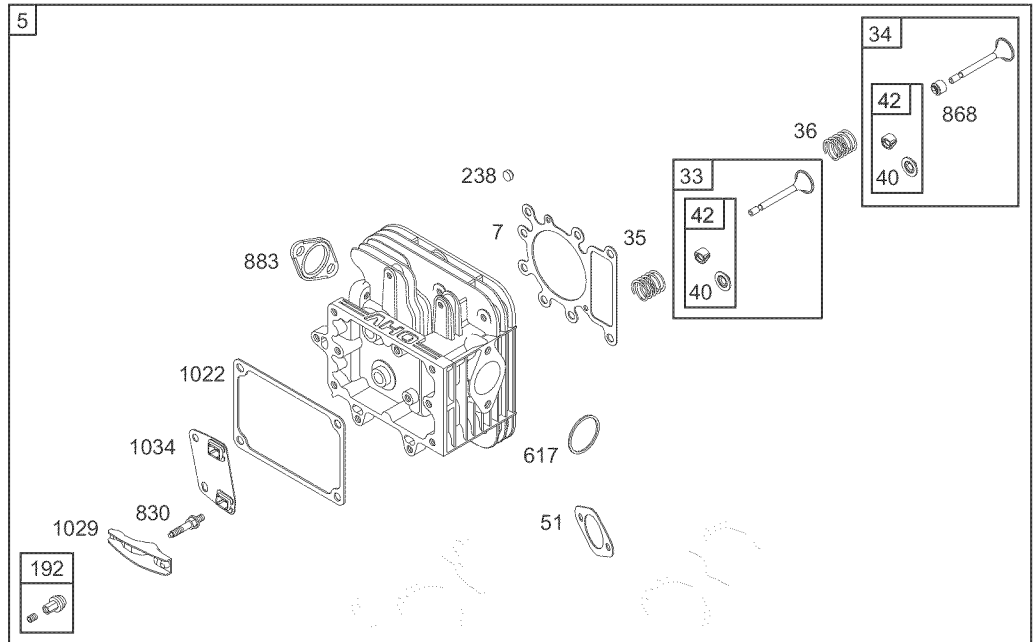
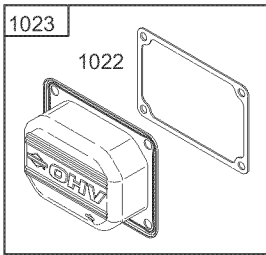
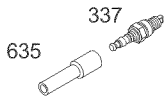

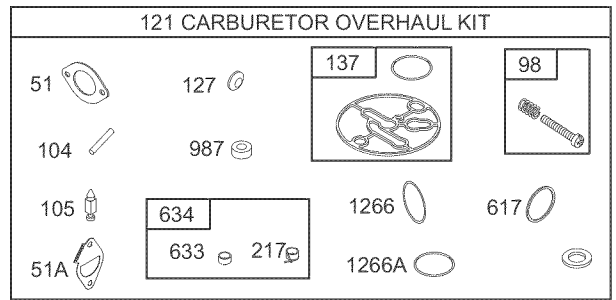
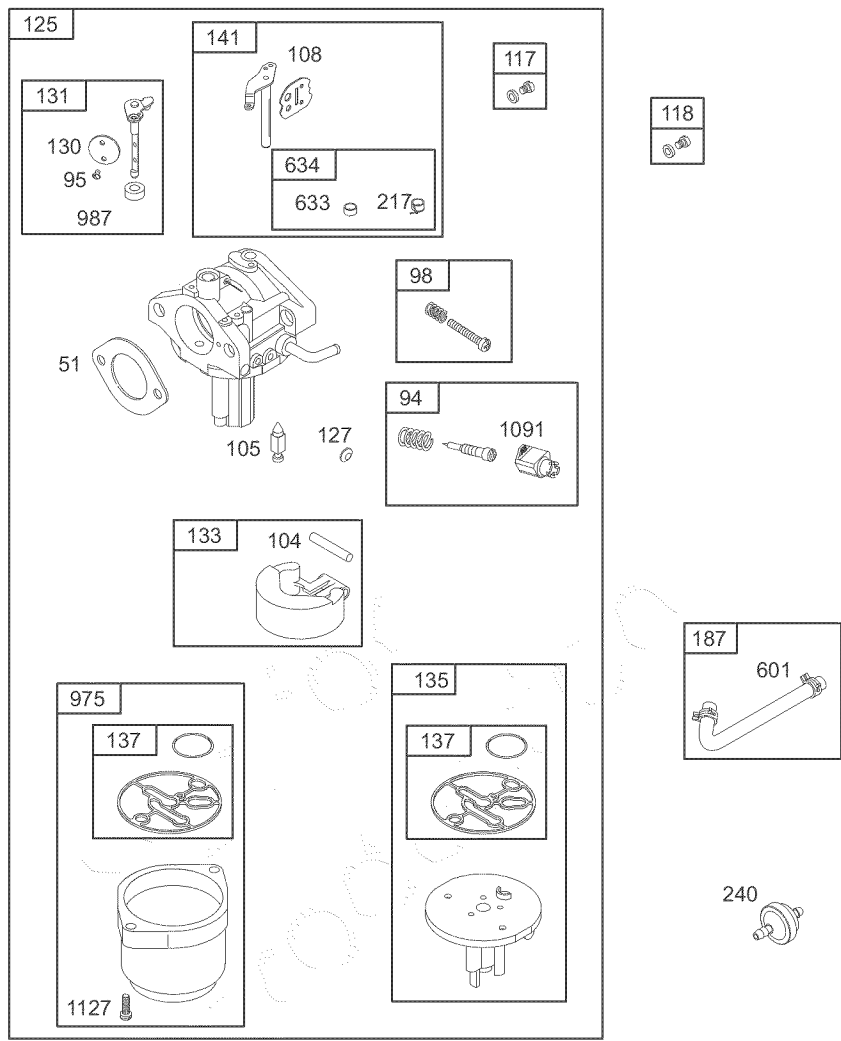

1036 EMISSIONS LABEL

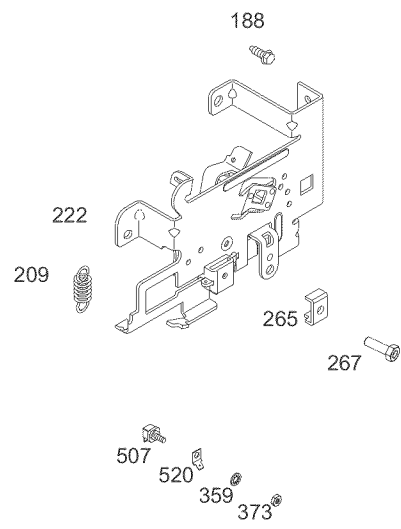
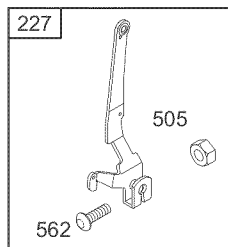
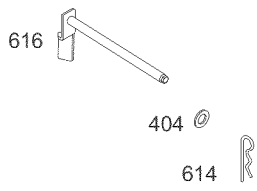
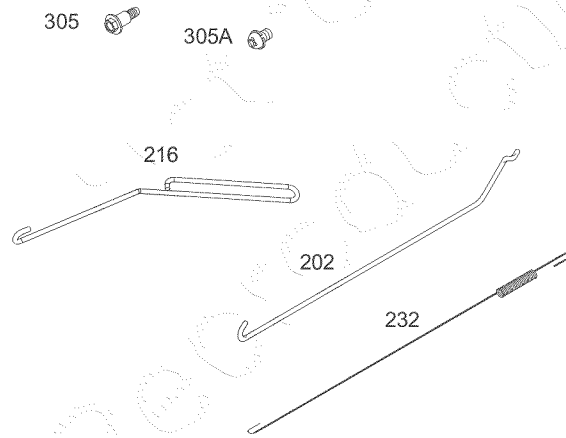
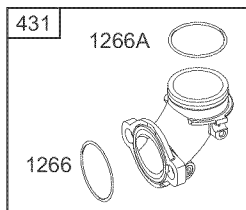
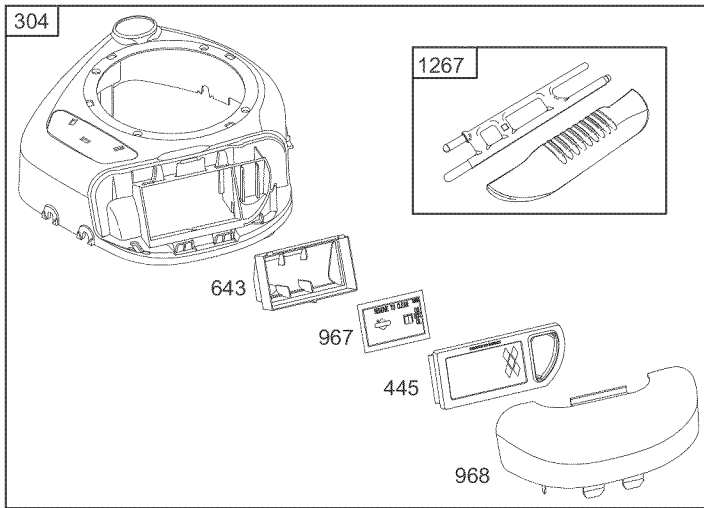

219977-0130-B1

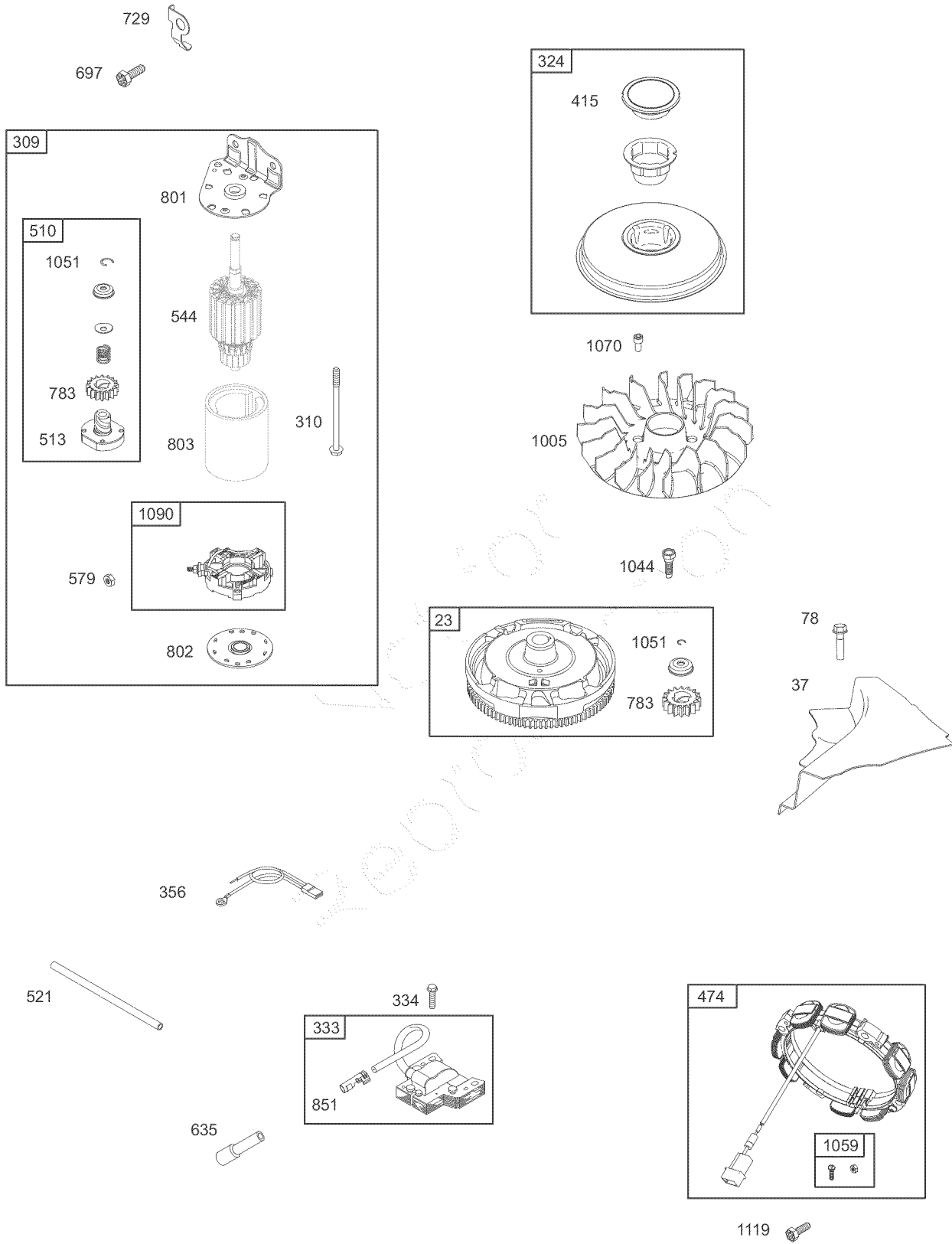

219977-0130-B1

REF. NO.	PART NO.	DESCRIPTION	REF. NO.	PART NO.	DESCRIPTION	REF. NO.	PART NO.	DESCRIPTION
1	697377	Cylinder Assembly	50	796188	Manifold-Intake	238	691843	Cap-Valve
2	399265	Kit-Bushing/Seal (Magneto Side)	51	692137	Gasket-Intake	240	394358s	Filter-Fuel
3	391086s	Seal-Oil (Magneto Side)	51A	796081	Gasket-Intake	265	691024	Clamp-Casing
4	697188	Sump-Engine	53	690227	Stud (Carburetor)	267	794904	Screw (Casing Clamp)
5	796183	Head-Cylinder	54	691148	Screw (Intake Manifold)	304	796414	Housing-Blower
7	273280s	Gasket- Cylinder Head	78	691003	Screw (Flywheel Guard)	305	697102	Screw (Blower Housing) (Long)
11	794683	Tube-Breather	94	793610	Kit-Idle Mixture	305A	793376	Screw (Blower Housing) (Short)
12	697110	Gasket-Crankcase	95	690718	Screw (Throttle Valve)	306	697359	Shield-Cylinder
13	690360	Screw (Cylinder Head)	98	695408	Kit-Idle Speed	307	691003	Screw (Cylinder Shield)
15	690946	Plug-Oil Drain	104	694918	Pin-Float Hinge	309	693551	Motor-Starter
16	697390	Crankshaft	105	696136	Valve-Float Needle	310	690323	Bolt (Starter Motor)
20	795387	Seal-Oil (PTO Side)	108	698773	Valve-Choke	324	796308	Screen/Cup Assembly
22	692125	Screw (Crankcase Cover/Sump)	117	796079	Jet-Main (Standard)	333	795315	Armature-Magneto
23	698281	Flywheel	118	796332	Jet-Main (High Altitude)	334	691061	Screw (Magneto Armature)
24	222698s	Key-Flywheel	121	796184	Kit- Carburetor Overhaul	337	691043	Plug-Spark
25	792307	Piston Assembly (Standard)	125	796077	Carburetor	356	398808	Wire-Stop
		----- Note -----	127	690727	Plug-Welch	358	796181	Gasket Set-Engine
		792728 Piston Assembly (.020" Oversize)	130	698774	Valve-Throttle	359	691077	Washer (Ground Terminal)
26	792306	Ring Set (Standard)	131	698776	Kit-Throttle Shaft	373	691612	Nut (Ground Terminal)
		----- Note -----	133	694914	Float-Carburetor	404	691691	Washer (Governor Crank)
		792643 Ring Set (.020" Oversize)	135	698780	Tube-Fuel Transfer	415	794129	Plug (Cover/Retainer)
27	698469	Lock-Piston Pin	137	698781	Gasket-Float Bowl	415A	794903	Plug (Intake Manifold)
28	697099	Pin-Piston	141	698778	Kit-Choke Shaft	431	697122	Elbow-Intake
29	791633	Rod-Connecting	146	691639	Key-Timing	445	797007	Filter- Air Cleaner Cartridge
32	791118	Screw (Connecting Rod)	186	794873	Connector-Hose (Intake Manifold)	474	696459	Alternator
33	791934	Valve-Exhaust	187	791805	Line-Fuel (Formed)	505	691251	Nut (Governor Control Lever)
34	791935	Valve-Intake				507	691972	Insulator
35	691279	Spring-Valve (Intake)				510	693699	Drive-Starter
36	691279	Spring-Valve (Exhaust)				513	692024	Clutch-Drive
37	697352	Guard-Flywheel	192	691986	Adjuster-Rocker Arm	520	691084	Terminal-Ground
40	690964	Retainer-Valve	202	691841	Link- Mechanical Governor	521	690581	Shield-Cable
42	499586	Keeper-Valve	209	792813	Spring-Governor (Brown)	523	699908	Dipstick
43	691968	Slinger-Governor/Oil	216	691840	Link-Choke	524	691032	Seal-Dipstick Tube
45	690564	Tappet-Valve	217	695409	Spring-Choke Return	525	697184	Tube-Dipstick Armature-Starter (Not Serviced Separately, Order Starter Motor 693551, Reference 309)
46	793880	Camshaft	222	694042	Bracket-Control	544		
			227	691374	Lever- Governor Control			
			232	691842	Spring-Governor Link			

Engine Gasket Set-Reference 358
Carburetor Overhaul Kit-Reference 121

Valve Gasket Set-Reference 1095

219977-0130-B1

REF. NO.	PART NO.	DESCRIPTION	REF. NO.	PART NO.	DESCRIPTION	REF. NO.	PART NO.	DESCRIPTION
552	697144	Bushing- Governor Crank	801	691283	Cap-Drive	1044	698139	Screw (Flywheel)
562	691119	Bolt (Governor Control Lever)	802	691286	Cap-End	1051	691265	Ring-Retaining
579	691029	Nut (Starter Cable)	803		Housing-Starter (Not Serviced Separately, Order Starter Motor 693551 , Reference 309)	1058	276344	Owner's Manual
584	794682	Cover- Breather Passage (Use With Liquid Sealant, Reference 850)	830	691095	Stud-Rocker Arm	1059	698516	Kit-Screw/Washer (Alternator)
585	697109	Gasket- Breather Passage	842	691031	Seal-O Ring (Dipstick Tube)	1070	690372	Screw (Flywheel Fan)
601	791850	Clamp-Hose (Green)	847	790442	Dipstick/Tube Assembly	1090	691293	Retainer-Brush
614	691620	Pin-Cotter (Governor Crank)	850	100106	Sealant-Liquid (Used to seal the Rocker Cover and/or Breather Passage Cover)	1091	691333	Cap-Limiter
616	692012	Crank-Governor	851	692424	Terminal-Spark Plug	1095	796189	Gasket Set-Valve
617	692138	Seal-O Ring (Intake Manifold) (Red)	868	690968	Seal-Valve	1119	691183	Screw (Alternator)
633	699813	Seal- Choke/Throttle Shaft (Choke Shaft)	883	692236	Gasket-Exhaust	1127	695407	Screw (Float Bowl)
634	698779	Spring/Seal Assembly (Choke Shaft)	914	691108	Screw (Rocker Cover)	1263	697124	Reed-Breather
635	691909	Boot-Spark Plug	943	690589	Seal-O Ring (Oil Pump Cover)	1264	697104	Screw (Breather Reed)
643	697155	Retainer-Air Filter	965	499613	Cover-Oil Pump	1266	691917	Seal-O Ring (Intake Elbow) (Red)
654	690958	Nut (Carburetor)	967	697292	Filter-Pre Cleaner	1266A	697123	Seal-O Ring (Intake Elbow)
684	697157	Screw (Breather Passage Cover)	968	697420	Cover-Air Cleaner	1267	697419	Latch-Blower Housing
691	692407	Seal-Governor Shaft	975	698783	Bowl-Float	1270	793243	Plug-AVS Counterweight
697	690372	Screw (Drive Cap)	987	698777	Seal-Throttle Shaft			
718	690959	Pin-Locating	1005	796082	Fan-Flywheel			
729	691224	Clip-Wire (Starter Motor)	1017	796981	Screen-Oil Pump			
741	697128	Gear-Timing	1022	272475s	Gasket-Rocker Cover			
750	790832	Screw-Oil Pump	1023	797421	Cover-Rocker			
757	793242	Link-Counterweight	1026	794573	Rod-Push (Exhaust) (Steel)			
758	697391	Counterweight			----- Note -----			
759	697392	Pin-Counterweight			697394 Rod-Push (Intake) (Aluminum)			
783	693713	Gear-Pinion	1027	492932s	Filter-Oil			
			1029	691751	Arm-Rocker			
			1034	690822	Guide-Push Rod			
			1036		Label-Emissions (Available from a Briggs & Stratton Authorized Dealer)			

Engine Gasket Set-Reference 358
Carburetor Overhaul Kit-Reference 121

Valve Gasket Set-Reference 1095

MSC000200-8

Assemblies include all parts shown in frames.

12/07/2009

Hardware Identification & Torque Specifications

Common Hardware Types

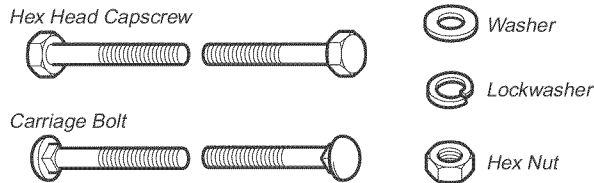

Standard Hardware Sizing

When a washer or nut is identified as 1/2", this is the *Nominal size*, meaning the *inside diameter* is 1/2 inch; if a second number is present it represents the *threads per inch*

When bolt or capscrew is identified as 1/2 - 16 x 2", this means the *Nominal size*, or *body diameter* is 1/2 inch; the second number represents the *threads per inch* (16 in this example, and the final number is the *body length* of the bolt or screw (in this example 2 inches long).

The guides and ruler furnished below are designed to help you select the appropriate hardware and tools.

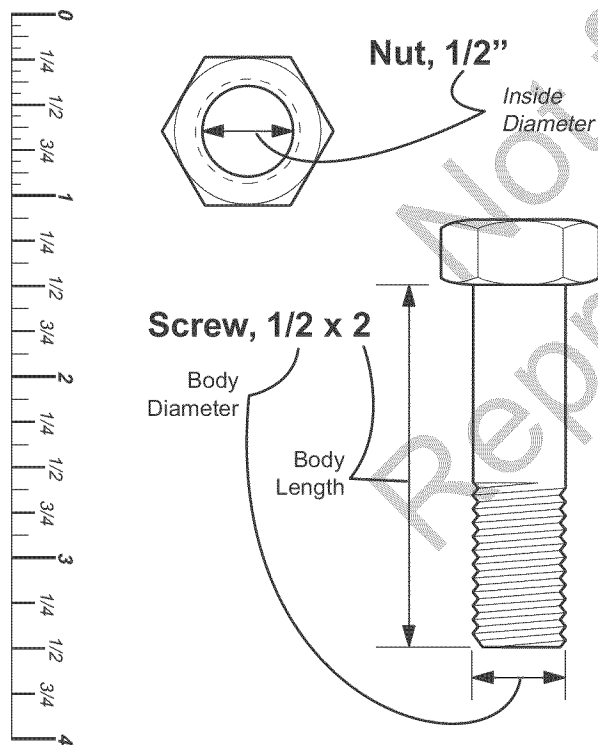

Torque Specification Chart						
FOR STANDARD MACHINE HARDWARE (Tolerance ± 20%)						
Hardware Grade	No Marks SAE Grade 2		SAE Grade 5		SAE Grade 8	
	in/lbs ft/lbs	Nm.	in/lbs ft/lbs	Nm.	in/lbs ft/lbs	Nm.
8-32	19	2.1	30	3.4	41	4.6
8-36	20	2.3	31	3.5	43	4.9
10-24	27	3.1	43	4.9	60	6.8
10-32	31	3.5	49	5.5	68	7.7
1/4-20	66	7.6	8	10.9	12	16.3
1/4-28	76	8.6	10	13.6	14	19.0
5/16-18	11	15.0	17	23.1	25	34.0
5/16-24	12	16.3	19	25.8	27	34.0
3/8-16	20	27.2	30	40.8	45	61.2
3/8-24	23	31.3	35	47.6	50	68.0
7/16-14	30	40.8	50	68.0	70	95.2
7/16-20	35	47.6	55	74.8	80	108.8
1/2-13	50	68.0	75	102.0	110	149.6
1/2-20	55	74.8	90	122.4	120	163.2
9/16-12	65	88.4	110	149.6	150	204.0
9/16-18	75	102.0	120	163.2	170	231.2
5/8-11	90	122.4	150	204.0	220	299.2
5/8-18	100	136	180	244.8	240	326.4
3/4-10	160	217.6	260	353.6	386	525.0
3/4-16	180	244.8	300	408.0	420	571.2
7/8-9	140	190.4	400	544.0	600	816.0
7/8-14	155	210.8	440	598.4	660	897.6
1-8	220	299.2	580	788.8	900	1,244.0
1-12	240	326.4	640	870.4	1,000	1,360.0

NOTES

- These torque values are to be used for all hardware excluding: locknuts, self-tapping screws, thread forming screws, sheet metal screws and socket head setscrews.
- Recommended seating torque values for locknuts:
 - for prevailing torque locknuts - use 65% of grade 5 torques.
 - for flange whizlock nuts and screws - use 135% of grade 5 torques.
- Unless otherwise noted on assembly drawings, all torque values must meet this specification.

Wrench & Fastener Size Guide



1/4" Bolt or Nut
Wrench—7/16"

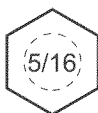

5/16" Bolt or Nut
Wrench—1/2"

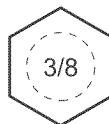

3/8" Bolt or Nut
Wrench—9/16"



7/16" Bolt or Nut
Wrench (Bolt)—5/8"
Wrench (Nut)—11/16"

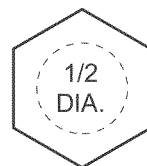

1/2" Bolt or Nut
Wrench—3/4"

Not for
reproduction

Not for
Reproduction

Get it fixed, at your home or ours!

Your Home

For expert troubleshooting and home solutions advice:

manage  my home

www.managemyhome.com

For repair – **in your home** – of **all** major brand appliances, lawn and garden equipment, or heating and cooling systems, **no matter who made it, no matter who sold it!**

For the replacement parts, accessories and owner's manuals that you need to do-it-yourself.

For Sears professional installation of home appliances and items like garage door openers and water heaters.

1-800-4-MY-HOME[®] (1-800-469-4663)

Call anytime, day or night (U.S.A. and Canada)

www.sears.com www.sears.ca

Our Home

For repair of carry-in items like vacuums, lawn equipment, and electronics, call anytime for the location of your nearest

Sears Parts & Repair Service Center

1-800-488-1222 (U.S.A.) **1-800-469-4663** (Canada)

www.sears.com

www.sears.ca

To purchase a protection agreement on a product serviced by Sears:

1-800-827-6655 (U.S.A.)

1-800-361-6665 (Canada)

Para pedir servicio de reparación a domicilio, y para ordenar piezas:

1-888-SU-HOGAR[®]

(1-888-784-6427)

Au Canada pour service en français:

1-800-LE-FOYER^{MC}

(1-800-533-6937)

www.sears.ca

