

Panasonic®

Operating Instructions High Definition Video Camera

Model No. **HDC-TM700P/PC**
HDC-HS700P/PC

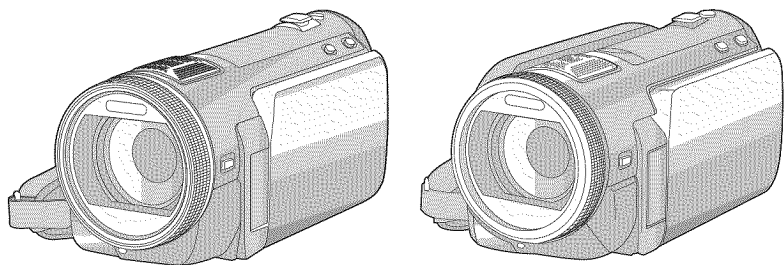

Before connecting, operating or adjusting this product, please read the instructions completely.
Spanish Quick Use Guide is included.

Guía para rápida consulta en español está incluida.

AVCHD™

DOLBY
DIGITAL
5.1 CREATOR

LEICA
DICOMAR

SD™
XC

HDMI

VIERA Link™

For USA and Puerto Rico assistance, please call: 1-800-211-PANA(7262) or,
contact us via the web at: <http://www.panasonic.com/contactinfo>

For Canadian assistance, please call: 1-800-561-5505 or visit us at www.panasonic.ca

VQT2M75

Things You Should Know

Thank you for choosing Panasonic! You have purchased one of the most sophisticated and reliable products on the market today. Used properly, we're sure it will bring you and your family years of enjoyment. Please take time to fill in the information on the right. The serial number is on the tag located on the back of your camera. Be sure to **retain this manual** as your convenient camera information source.

Date of Purchase _____

Dealer Purchased From _____

Dealer Address _____

Dealer Phone No. _____

Model No. _____

Serial No. _____

Safety Precautions

WARNING:





TO REDUCE THE RISK OF FIRE, ELECTRIC SHOCK OR PRODUCT DAMAGE,

- DO NOT EXPOSE THIS APPARATUS TO RAIN, MOISTURE, DRIPPING OR SPLASHING AND THAT NO OBJECTS FILLED WITH LIQUIDS, SUCH AS VASES, SHALL BE PLACED ON THE APPARATUS.
- USE ONLY THE RECOMMENDED ACCESSORIES.
- DO NOT REMOVE THE COVER (OR BACK); THERE ARE NO USER SERVICEABLE PARTS INSIDE. REFER SERVICING TO QUALIFIED SERVICE PERSONNEL.

CAUTION!

DO NOT INSTALL OR PLACE THIS UNIT IN A BOOKCASE, BUILT-IN CABINET OR IN ANOTHER CONFINED SPACE. ENSURE THE UNIT IS WELL VENTILATED. TO PREVENT RISK OF ELECTRIC SHOCK OR FIRE HAZARD DUE TO OVERHEATING, ENSURE THAT CURTAINS AND ANY OTHER MATERIALS DO NOT OBSTRUCT THE VENTILATION VENTS.

The following mark and symbols are located on bottom of the unit.

  	
<p>CAUTION: TO REDUCE THE RISK OF ELECTRIC SHOCK, DO NOT REMOVE SCREWS. NO USER-SERVICEABLE PARTS INSIDE. REFER SERVICING TO QUALIFIED SERVICE PERSONNEL.</p>	<p>The lightning flash with arrowhead symbol, within an equilateral triangle, is intended to alert the user to the presence of uninsulated "dangerous voltage" within the product's enclosure that may be of sufficient magnitude to constitute a risk of electric shock to persons.</p>
	 <p>The exclamation point within an equilateral triangle is intended to alert the user to the presence of important operating and maintenance (servicing) instructions in the literature accompanying the appliance.</p>

THE FOLLOWING APPLIES ONLY IN THE U.S.A.

FCC Note:

This equipment has been tested and found to comply with the limits for a Class B digital device, pursuant to Part 15 of the FCC Rules. These limits are designed to provide reasonable protection against harmful interference in a residential installation. This equipment generates, uses, and can radiate radio frequency energy and, if not installed and used in accordance with the instructions, may cause harmful interference to radio communications. However, there is no guarantee that interference will not occur in a particular installation. If this equipment does cause harmful interference to radio or television reception, which can be determined by turning the equipment off and on, the user is encouraged to try to correct the interference by one or more of the following measures:

- Reorient or relocate the receiving antenna.
- Increase the separation between the equipment and receiver.
- Connect the equipment into an outlet on a circuit different from that to which the receiver is connected.
- Consult the dealer or an experienced radio/TV technician for help.

FCC Caution: To assure continued compliance, follow the attached installation instructions and use only shielded interface cables with ferrite core when connecting to computer or peripheral devices.

Any changes or modifications not expressly approved by the party responsible for compliance could void the user's authority to operate this equipment.

Declaration of Conformity

Trade Name: Panasonic
Model No.: HDC-TM700P/HDC-HS700P
Responsible party: Panasonic Corporation of North America
One Panasonic Way, Secaucus, NJ 07094
Support Contact: Panasonic Consumer Electronics Company
1-800-211-PANA (7262)

This device complies with Part 15 of the FCC Rules. Operation is subject to the following two conditions: (1) This device may not cause harmful interference, and (2) this device must accept any interference received, including interference that may cause undesired operation.



THE FOLLOWING APPLIES ONLY IN CANADA.

This Class B digital apparatus complies with Canadian ICES-003.

Batteries

1 Battery pack (Lithium ion battery pack)

- Use the specified unit to recharge the battery pack.
- Do not use the battery pack with equipment other than the specified unit.
- Do not get dirt, sand, liquids, or other foreign matter on the terminals.
- Do not touch the plug terminals (+ and -) with metal objects.
- Do not disassemble, remodel, heat or throw into fire.

2 Button-type battery (Lithium battery)

- Insert with poles aligned.
- Do not touch the terminals (+ and -) with metal objects.
- Do not recharge, disassemble, remodel, heat or throw into fire.
- Keep out of reach of children

If any electrolyte should come into contact with your hands or clothes, wash it off thoroughly with water.

If any electrolyte should come into contact with your eyes, never rub the eyes. Rinse eyes thoroughly with water, and then consult a doctor.

Warning

Risk of fire, explosion and burns. Do not disassemble.

Do not heat the batteries above the following temperatures or incinerate.

Button-type battery 60 °C (140 °F)

Battery pack 60 °C (140 °F)

AC adaptor

This AC adaptor operates on AC between 110 V and 240 V.

But

- In the U.S.A. and Canada, the AC adaptor must be connected to a 120 V AC power supply only.
- When connecting to an AC supply outside of the U.S.A. or Canada, use a plug adaptor to suit the AC outlet configuration.
- When connecting to a supply of greater than AC 125 V, ensure the cord you use is suited to the voltage of the AC supply and the rated current of the AC adaptor.
- Contact an electrical parts distributor for assistance in selecting a suitable AC plug adaptor or AC cord set.

The unit should be installed near an accessible AC power outlet, with the power cord connected directly to it.

To completely disconnect power from the unit, unplug the power cord from the AC power outlet.

■ Concerning the AC adaptor

Product Identification Marking is located on the bottom of unit.

U.S.A./CANADA CONSUMERS: ATTENTION:



A lithium ion/polymer battery that is recyclable powers the product you have purchased. Please call 1-800-8-BATTERY for information on how to recycle this battery.

<For USA-California only>

This product contains a CR Coin Cell Lithium Battery which contains Perchlorate Material – special handling may apply.

See www.dtsc.ca.gov/hazardouswaste/perchlorate.

IMPORTANT SAFETY INSTRUCTIONS

Read these operating instructions carefully before using the unit. Follow the safety instructions on the unit and the applicable safety instructions listed below. Keep these operating instructions handy for future reference.

- 1) Read these instructions.
- 2) Keep these instructions.
- 3) Heed all warnings.
- 4) Follow all instructions.
- 5) Do not use this apparatus near water.
- 6) Clean only with dry cloth.
- 7) Do not block any ventilation openings. Install in accordance with the manufacturer's instructions.
- 8) Do not install near any heat sources such as radiators, heat registers, stoves, or other apparatus (including amplifiers) that produce heat.
- 9) Do not defeat the safety purpose of the polarized or grounding-type plug. A polarized plug has two blades with one wider than the other. A grounding-type plug has two blades and a third grounding prong. The wide blade or the third prong are provided for your safety. If the provided plug does not fit into your outlet, consult an electrician for replacement of the obsolete outlet.
- 10) Protect the power cord from being walked on or pinched particularly at plugs, convenience receptacles, and the point where they exit from the apparatus.
- 11) Only use attachments/accessories specified by the manufacturer.
- 12) Use only with the cart, stand, tripod, bracket, or table specified by the manufacturer, or sold with the apparatus. When a cart is used, use caution when moving the cart/apparatus combination to avoid injury from tip-over.
- 13) Unplug this apparatus during lightning storms or when unused for long periods of time.
- 14) Refer all servicing to qualified service personnel. Servicing is required when the apparatus has been damaged in any way, such as power-supply cord or plug is damaged, liquid has been spilled or objects have fallen into the apparatus, the apparatus has been exposed to rain or moisture, does not operate normally, or has been dropped.



Precautions

USE & LOCATION

WARNING

- **TO AVOID SHOCK HAZARD ...** Your camera and power supply should not be exposed to rain or moisture. Do not connect the power supply or operate your camera if it gets wet. Your camera has been designed for outdoor use, however it is not designed to sustain direct exposure to water, rain, sleet, snow, sand, dust, or a direct splashing from a pool or even a cup of coffee. This action could permanently damage the internal parts of your camera. Do not attempt to disassemble this unit. There are no user serviceable parts inside. Unplug your camera from the power supply before cleaning.
- **AS WITH ANY SMALL OBJECT, SD CARDS CAN BE SWALLOWED BY YOUNG CHILDREN. DO NOT ALLOW CHILDREN TO HANDLE THE SD CARD.**

CAUTION

- **DO NOT AIM YOUR CAMERA AT THE SUN OR OTHER BRIGHT OBJECTS**
- **DO NOT LEAVE THE CAMERA WITH THE EVF AIMED DIRECTLY AT THE SUN AS THIS MAY CAUSE DAMAGE TO THE INTERNAL PARTS OF THE EVF**
- **DO NOT EXPOSE YOUR CAMERA TO EXTENDED HIGH TEMPERATURE ...** Such as, in direct sunlight, inside a closed car, next to a heater, etc... This action could permanently damage the internal parts of your camera.
- **AVOID SUDDEN CHANGES IN TEMPERATURE ...** If the unit is suddenly moved from a cold place to a warm place, moisture may form on the SD card and inside the unit.
- **DO NOT LEAVE YOUR CAMERA OR THE POWER SUPPLY TURNED ON WHEN NOT IN USE.**
- **STORAGE OF YOUR CAMERA ...** Store and handle your camera in a manner that

will not subject it to unnecessary movement (avoid shaking and striking). Your camera contains a sensitive pick-up device which could be damaged by improper handling or storage.

CARE

- **TO CLEAN YOUR CAMERA ...** Do not use strong or abrasive detergents when cleaning your camera body.
- **TO PROTECT THE LENS ...** Do not touch the surface of the lens with your hand. Use a commercial camera lens solution and lens paper when cleaning the lens. Improper cleaning can scratch the lens coating.
- **TO PROTECT THE FINISH OF YOUR CAMERA ...** Before handling your camera, make sure your hands and face are free from any chemical products, such as suntan lotion, as it may damage the finish.

-If you see this symbol-

Information on Disposal in other Countries outside the European Union



This symbol is only valid in the European Union.

If you wish to discard this product, please contact your local authorities or dealer and ask for the correct method of disposal.

■ Indemnity about recorded content

Panasonic does not accept any responsibility for damages directly or indirectly due to any type of problems that result in loss of recording or edited content, and does not guarantee any content if recording or editing does not work properly. Likewise, the above also applies in a case where any type of repair is made to the unit (including any other non-built-in memory/HDD related component).

■ Handling of built-in memory [HDC-TM700]

This unit is equipped with the built-in 32 GB memory. When using this component, pay attention to the following points.

Back up data periodically.

The built-in memory is temporary storage. In order to avoid erasing data due to static electricity, electromagnetic waves, breakage, and failures, back up the data to a PC or DVD disc. (→ 109, 117)

- Access lamp [ACCESS] (→ 16) illuminates while the SD card or built-in memory is being accessed (initialization, recording, playback, deleting etc.). Do not perform the following operations when the lamp illuminates. It may damage the built-in memory or cause a malfunction in the unit.
 - Turn the unit off (remove the battery)
 - Insert and remove the USB cable
 - Expose the unit to vibrations or shock
- About disposing of or giving away this unit. (→ 142)

■ Handling of HDD [HDC-HS700]

This unit is equipped with the built-in 240 GB HDD. While the HDD is capable of storing a large amount of data, there are a few things to look out for. When using this component, pay attention to the following points.

Do not expose the HDD to vibrations and shocks.

Due to the environment and handling conditions, the HDD may be subject to

partial damages or may not be able to read, record, and play back data. Do not expose the unit to vibrations or shock, and do not turn off the power during recording or playback.

If the unit is used in a place with loud sounds, such as a club or similar venue, the recording may stop due to sound vibrations. Recording data on an SD card is recommended in these places.

Back up data periodically.

The HDD is temporary storage. In order to avoid erasing data due to static electricity, electromagnetic waves, breakage, and failures, back up the data to a PC or DVD disc. (→ 109, 117)

If the HDD experiences any abnormality, back up data immediately.

Failure in the HDD may produce continuous noise or choppy sound during recording or playing back. Continuous use will cause further deterioration, and may eventually disable the HDD. If these phenomena are observed, copy the data on the HDD to a PC, a DVD disc etc. immediately and contact consumer support. (→ 161, 162) Once the HDD is out of order, data cannot be restored.

Operation may stop in hot or cold environments.

The unit is disabled in order to protect the HDD.

Do not use the unit in low atmospheric pressures.

The HDD may fail if it is used at altitudes of 3000 m (9800 feet) or higher above sea level.

Transportation

When the unit is transported, turn off the power and be careful not to shake, drop, or cause impact to the unit.

Falling detection

[] is indicated on the screen when it detects a falling state (a weightless state). If the falling state is detected repeatedly, the

unit may stop the recording or playback operation in order to protect the HDD.

- HDD access lamp [ACCESS HDD] (→ 21) illuminates while the HDD is being accessed (initialization, recording, playback, deleting etc.). Do not perform the following operations when the lamp illuminates. It may damage the HDD or cause a malfunction in the unit.
 - Turn the unit off (remove the battery)
 - Insert and remove the USB cable
 - Expose the unit to vibrations or shock
- About disposing of or giving away this unit. (→ 142)

■ Cards that you can use with this unit

SD Memory Card, SDHC Memory Card and SDXC Memory Card

- 4 GB or more Memory Cards that do not have the SDHC logo or 48 GB or more Memory Cards that do not have the SDXC logo are not based on SD Memory Card Specifications.
- Refer to page 27 for more details on SD cards.

■ For the purposes of these operating instructions

- SD Memory Card, SDHC Memory Card and SDXC Memory Card are referred to as the "SD card".
- Functions that can be used for motion picture recording/motion picture playback are indicated by **VIDEO** in these operating instructions.
- Functions that can be used for still picture recording/still picture playback are indicated by **PHOTO** in these operating instructions.
- Pages for reference are indicated by an arrow, for example: → 00

These operating instructions are designed for use with models **HDC-TM700** and **HDC-HS700**. Pictures may be slightly different from the original.

- The illustrations used in these operating instructions show model **HDC-TM700**, however, parts of the explanation refer to different models.
- Depending on the model, some functions are not available.
- Features may vary, so please read carefully.
- Not all models may be available depending on the region of purchase.

Contents

Accessories	12
Quick Guide	13

Preparation

Before using

1 Parts identification and handling	16
[HDC-TM700]	16
[HDC-HS700]	19

Setup

1 Power supply	22
Charging the battery	22
Inserting/removing the battery	23
Charging and recording time	24
Connecting to the AC outlet	26
2 Recording to a card	27
Cards that you can use with this unit	27
Inserting/removing an SD card	28
3 Turning the unit on/off	29
Turning the power on and off with the power button	29
Turning the power on and off with the LCD monitor/viewfinder	29
4 Selecting a mode	30
5 Adjusting LCD monitor/viewfinder	31
How to use the touch screen	31
Viewfinder adjustment	31
Recording showing the contents to a partner	31
6 Setting date and time	32

Basic

Recording/Playback

1 Before recording	33
2 Selecting a media to record	34
3 Recording motion pictures	35
4 Recording still pictures	37
Recording still pictures in Motion Picture Recording Mode	38
5 Intelligent Auto Mode	39
6 Motion picture/Still picture playback	41

Setup

1 Using the menu screen	44
Using the quick menu	45
2 Using the Setup Menu	46
3 Using with the remote control	53
Operation of direction buttons/OK button	54

Advanced

Recording (Advanced)

1 Zoom in/out function	55
Ring zoom	55
Extra Optical Zoom	55
2 Optical Image Stabilizer Function	56
3 AF/AE tracking	57
4 1080/60p recording	58
5 Recording functions of operation icons	59
Operation icons	59
6 Recording functions of menus	65
7 Recording manually by setting white balance, shutter speed or iris adjustment	82
White balance	83
Manual shutter speed/iris adjustment	84
8 Recording with Manual focus	85

Playback (Advanced)

1 Playback Operations	86
Motion picture playback using operation icon	86
Creating still picture from motion picture	87
Highlight&Time frame index	88
Repeat playback	88
Resuming the previous playback	89
Zooming in on a still picture during playback (Playback zoom)	89
2 Various playback functions	90

Playing back motion pictures/ still pictures by date	90
Face Highlight Playback/ Highlight Playback/ Intelligent Scene Selection.....	91
Changing the playback settings and playing back the slide show	94

Editing

1 Deleting scenes/still pictures ...	95
Dividing a scene to partially delete	96
Deleting personal information	97
Protecting scenes/still pictures.....	97
2 DPOF setting	98
3 Relay scene combining [HDC-TM700]	99

With a TV

1 Watching Video/Pictures on your TV	101
Connecting with a HDMI mini cable.....	104
Listening in 5.1 channel sound	104
Connecting with the AV multi cable	104
2 Playback using VIERA Link™ (HDMI Control™)	105

Copy/Dubbing

With this unit/other products

1 Copying between SD card and Built-in Memory/HDD	107
Copying	107
2 Connecting a DVD burner to copy to/play back a disc.....	109
Preparing for copying/ playing back	109
Copying to discs.....	111
Playing back the copied disc.....	114
Managing the copied disc	115
3 Dubbing images onto other video devices	116

With a PC

Before using

1 What you can do with a PC	117
End User License Agreement....	119
2 Operating environment	120

Setup

1 Installation	123
2 Connecting to a PC.....	125
About the PC display	127

Using with a PC

1 Starting HD Writer AE 2.1	128
Reading the operating instructions of the software applications	128
2 If using Mac	129

Others

Indications

1 Indications	130
2 Messages	133
About recovery.....	134

Troubleshooting

Cautions for use

About copyright

Recording modes/ approximate recordable time

Number of recordable pictures

Specifications

Optional accessories

Accessory Order Form (For USA and Puerto Rico Customers)	159
--	-----

Limited Warranty (ONLY FOR U.S.A. AND PUERTO RICO).....

Warranty (For Canadian Customers).....

Index

Spanish Quick Use Guide/ Guía española para el uso rápido

165

Accessories

Check the accessories before using this unit.

Product numbers correct as of Feb. 2010. These may be subject to change.

Battery pack

VW-VBG130



CD-ROM

Software



AC adaptor

VSK0697



AC cable

K2CA2CA00025



DC cable

K2GJYDC00004



Remote control

(Built-in battery)

N2QAEC000024



AV multi cable

K1HY12YY0004



USB cable

K1HY04YY0032



Stylus pen

VGQ0C14



Lens hood

VDW2053



Shoe adaptor

(supplied for HDC-TM700;
not supplied for HDC-HS700)

VYC0996



Quick Guide

■ Charging the battery

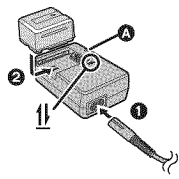

**Charging lamp
[CHARGE] A**

Lights up:
Charging
Goes off:
Charging completed

- 1) Connect the AC cable to the AC adaptor and the AC outlet.
- 2) Insert the battery into the AC adaptor by aligning the arrows.

■ Inserting the battery

Install the battery by inserting it in the direction shown in the figure.

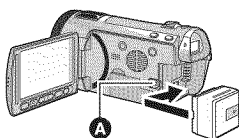

- A) Insert the battery until it clicks and locks.

■ Inserting/removing an SD card

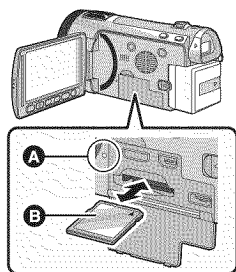

Access lamp [ACCESS] A

- When this unit is accessing the SD card or built-in memory, the access lamp lights up.

- 1) Open the LCD monitor.
- 2) Open the SD card/terminal cover and insert (remove) the SD card into (from) the card slot.
 - Face the label side **B** in the direction shown in the illustration and press it straight in as far as it will go.
 - Press the center of the SD card and then pull it straight out.
- 3) Securely close the SD card/terminal cover.
 - Securely close it until it clicks.

■ Turning the unit on/off

Turning the power on and off with the power button

Press the power button to turn on the power.

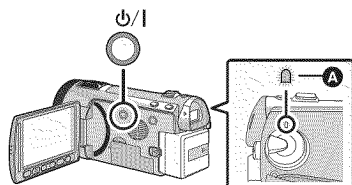

- A) The status indicator lights.
- To turn off the power, hold down the power button until the status indicator goes off.

Turning the power on and off with the LCD monitor/viewfinder

Opening the LCD monitor or extending the viewfinder turns on the power. Closing the LCD monitor/viewfinder turns off the power.
To turn on the power

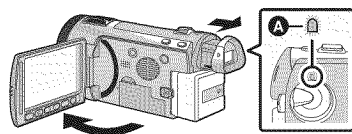

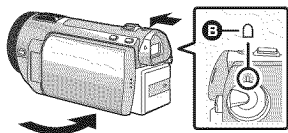

- A) The status indicator lights on.

To turn off the power





- B** The status indicator goes off.

■ Selecting a mode

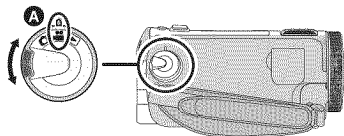
Operate the mode dial to change the mode to ,  or .



- Align with the status indicator **A**.

	Motion Picture Recording Mode (→ 35)
	Still Picture Recording Mode (→ 37)
	Playback Mode (→ 41, 86)

■ How to use the touch screen

You can operate by directly touching the LCD monitor (touch screen) with your finger. It is easier to use the stylus pen (supplied) for detailed operation or if it is hard to operate with your fingers.

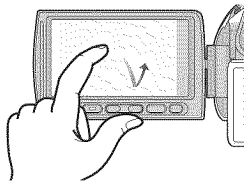

Touch and release the touch screen to select icon or picture.



■ Language selection

- 1) Press the MENU button, then touch [SETUP] → [LANGUAGE].
- 2) Touch [English].

■ Selecting a media to record

- 1) Change the mode to  or .
- 2) Select the menu.



 : [MEDIA SELECT]

- 3) Touch the media to record motion pictures or still pictures.
 - Touch [VIDEO/SD CARD] or [PICTURE/SD CARD] to record to the SD card.
HDC-TM700
Touch [VIDEO/Built-inMemory] or [PICTURE/Built-inMemory] to record to the built-in memory.
HDC-HS700
Touch [VIDEO/HDD] or [PICTURE/HDD] to record to the HDD.
 - The media is selected separately to motion pictures or still pictures is highlighted in yellow.
- 4) Touch [ENTER].

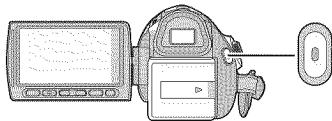

■ Recording motion pictures

- 1) Change the mode to .
- 2) Open the LCD monitor or extend the viewfinder.
- 3) Press the recording start/stop button to start recording.



- When you begin recording,  changes to .

■ Recording still pictures

- 1) Change the mode to .
- 2) Open the LCD monitor or extend the viewfinder.
- 3) Press the  button fully to take the picture.

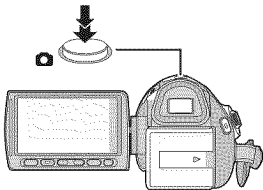



■ Motion picture/Still picture playback

- 1) Change the mode to .
- 2) Touch the play mode select icon **A**.



- 3) Touch the desired media to be played back motion pictures or still pictures.
- Touch [VIDEO/SD CARD] or [PICTURE/SD CARD] to play back the SD card.
HDC-TM700
Touch [VIDEO/Built-inMemory] or [PICTURE/Built-inMemory] to play back the built-in memory.
HDC-HS700
Touch [VIDEO/HDD] or [PICTURE/HDD] to play back the HDD.
- 4) Touch the scene or the still picture to be played back.







- Next (previous) page can be displayed by touching  / .

- 5) Select the playback operation by touching the operation icon.









- A** Operation icon

(Motion picture playback)

- : Playback/Pause
- : Rewind playback
- : Fast forward playback
- : Stops the playback and shows the thumbnails.
- : Displays the direct playback bar. (→ 87)

(Still picture playback)

- : Slide show (playback of the still pictures in numerical order) start/pause.
- : Plays back the previous picture.
- : Plays back the next picture.
- : Stops the playback and shows the thumbnails.
- Touch  /  to display/not-display the operation icon.

1

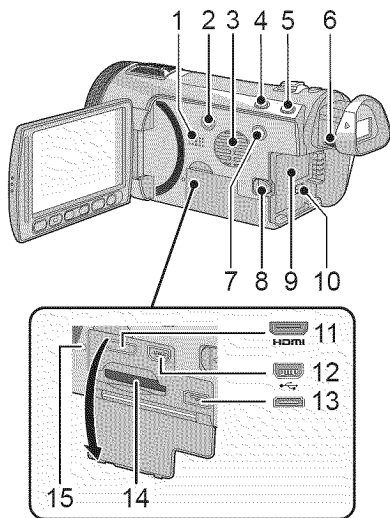

Parts identification and handling

[HDC-TM700]

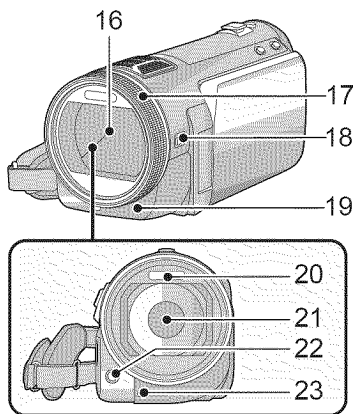

- 1 Speaker
 - 2 Power button [⏻/⏺] (→ 29)
 - 3 Inlet (cooling fan) (→ 33)
 - 4 Intelligent auto/Manual button [iA/MANUAL] (→ 39, 82)
 - 5 Optical image stabilizer button [(⏏)]/O.I.S.] (→ 56)
 - 6 Eyepiece corrector dial (→ 31)
 - 7 1080/60p button [1080/60p] (→ 58)
 - 8 Battery release lever [BATT] (→ 23)
 - 9 Battery holder (→ 23)
 - 10 DC input terminal [DC IN] (→ 26)
- Always use the supplied AC adaptor or a genuine Panasonic AC adaptor (VW-AD21PP-K; optional).
- 11 HDMI mini connector [HDMI] (→ 101, 105)
 - 12 USB terminal [↔] (→ 110, 125)
 - 13 AV multi connector (→ 101, 116)
- Use the AV multi cable (only the supplied cable).
- 14 Card slot (→ 28)
 - 15 Access lamp [ACCESS] (→ 28)



- 16 Lens cover
- The lens cover opens in  Motion Picture Recording Mode or  Still Picture Recording Mode. (→ 30)
- 17 Multi manual ring (→ 82, 85)
 - 18 Camera function button [CAMERA FUNCTION] (→ 82)
 - 19 Remote control sensor (→ 54)
 - 20 Built-in flash (→ 61)
 - 21 Lens (LEICA DICOMAR)
- Please refer to page 33 for details about attaching the lens hood.
- 22 AF assist lamp (→ 81)
 - 23 Recording lamp (→ 49)

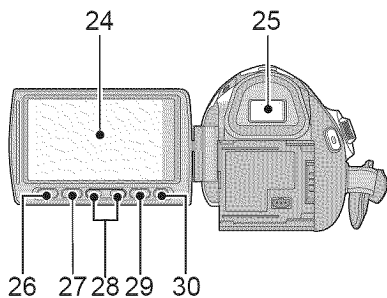

24 LCD monitor (Touch screen) (→ 31)

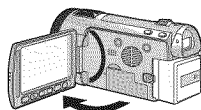

- It can open up to 90°.

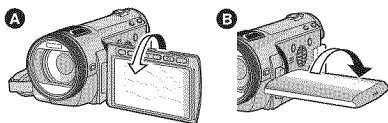

- It can rotate up to 180° **A** towards the lens or 90° **B** towards the viewfinder.

Due to limitations in LCD production technology, there may be some tiny bright or dark spots on the LCD monitor screen. However, this is not a malfunction and does not affect the recorded picture.

25 Viewfinder (→ 31)

Due to limitations in LCD production technology, there may be some tiny bright or dark spots on the viewfinder screen. However, this is not a malfunction and does not affect the recorded picture.

26 Quick menu button [Q.MENU] (→ 45)

27 Sub recording start/stop button (→ 33)

- This button functions in the same manner as the recording start/stop button.

28 Adjust zoom buttons (→ 55)

29 Menu button [MENU] (→ 44)

30 Delete button [] (→ 95)

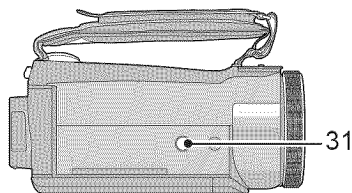

31 Tripod receptacle

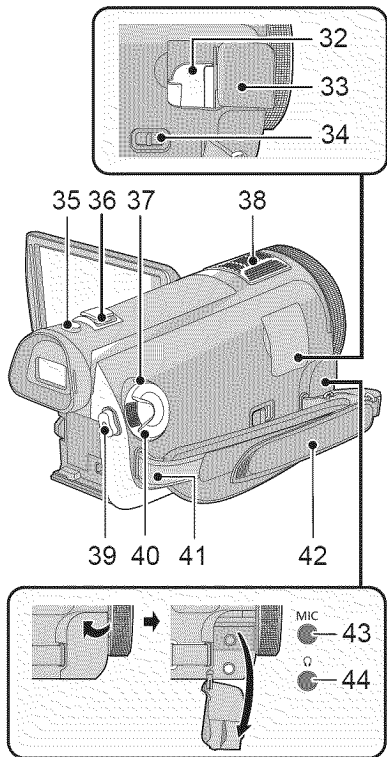

- 32 Shoe adaptor mount (→ 157)
- 33 Shoe adaptor cover (→ 157)
- 34 Shoe adaptor release lever
[SHOE ADAPTOR RELEASE] (→ 157)
- 35 Photoshot button [] (→ 37)
- 36 Zoom lever [W/T] (In Motion Picture
Recording Mode or Still Picture
Recording Mode) (→ 55)
- 37 Status indicator (→ 29)
- 38 Internal microphones
- 39 Recording start/stop button (→ 35)
- 40 Mode dial (→ 30)
- 41 Shoulder strap fixture
- 42 Grip belt

Adjust the length of the grip belt so that it fits your hand.

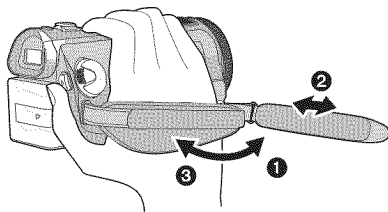

- ① Flip the belt.
- ② Adjust the length.
- ③ Replace the belt.

43 Microphone terminal [MIC]

- A compatible plug-in powered microphone can be used as an external microphone.
- Audio will be stereo (2 ch) with the external microphone input.
- When the unit is connected with the AC adaptor, sometimes noise may be heard depending on the microphone type. In this case, please switch to the battery for the power supply and the noise will stop.

44 Headphone terminal [] (→ 64)

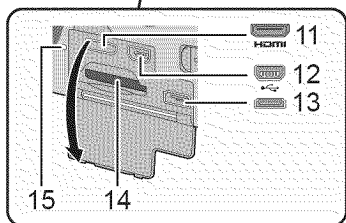
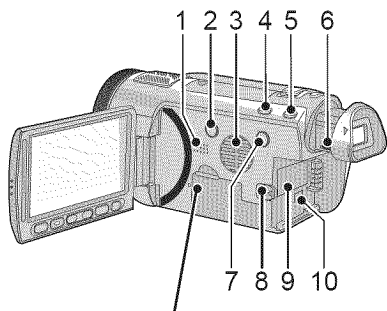

- 1 Speaker
- 2 Power button [⏻/⏺] (→ 29)
- 3 Inlet (cooling fan) (→ 33)
- 4 Intelligent auto/Manual button [iA/MANUAL] (→ 39, 82)
- 5 Optical image stabilizer button [O.I.S.] (→ 56)
- 6 Eyepiece corrector dial (→ 31)
- 7 1080/60p button [1080/60p] (→ 58)
- 8 Battery release lever [BATT] (→ 23)
- 9 Battery holder (→ 23)
- 10 DC input terminal [DC IN] (→ 26)
 - Always use the supplied AC adaptor or a genuine Panasonic AC adaptor (VW-AD21PP-K; optional).
- 11 HDMI mini connector [HDMI] (→ 101, 105)
- 12 USB terminal [↔] (→ 110, 125)
- 13 AV multi connector (→ 101, 116)
 - Use the AV multi cable (only the supplied cable).
- 14 Card slot (→ 28)
- 15 Access lamp [ACCESS] (→ 28)

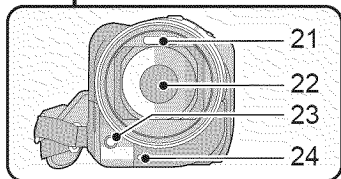
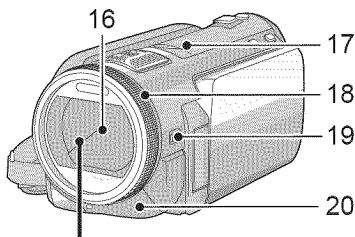

- 16 Lens cover
 - The lens cover opens in Motion Picture Recording Mode or Still Picture Recording Mode. (→ 30)
- 17 Accessory shoe (→ 158)
- 18 Multi manual ring (→ 82, 85)
- 19 Camera function button [CAMERA FUNCTION] (→ 82)
- 20 Remote control sensor (→ 54)
- 21 Built-in flash (→ 61)
- 22 Lens (LEICA DICOMAR)
 - Please refer to page 33 for details about attaching the lens hood.
- 23 AF assist lamp (→ 81)
- 24 Recording lamp (→ 49)

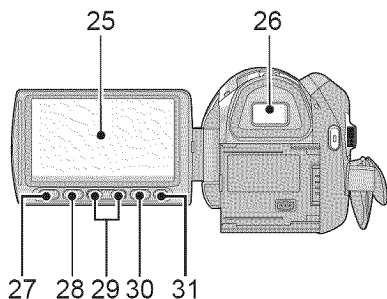

25 LCD monitor (Touch screen) (→ 31)

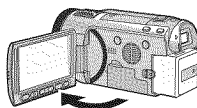

- It can open up to 90°.

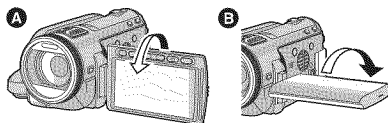

- It can rotate up to 180° **A** towards the lens or 90° **B** towards the viewfinder.

Due to limitations in LCD production technology, there may be some tiny bright or dark spots on the LCD monitor screen. However, this is not a malfunction and does not affect the recorded picture.

26 Viewfinder (→ 31)

Due to limitations in LCD production technology, there may be some tiny bright or dark spots on the viewfinder screen. However, this is not a malfunction and does not affect the recorded picture.

27 Quick menu button [Q.MENU] (→ 45)

28 Sub recording start/stop button (→ 33)

- This button functions in the same manner as the recording start/stop button.

29 Adjust zoom buttons (→ 55)

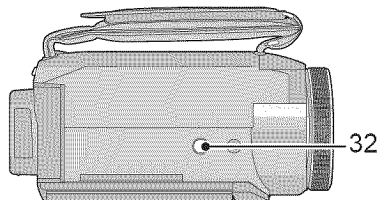

30 Menu button [MENU] (→ 44)

31 Delete button [] (→ 95)

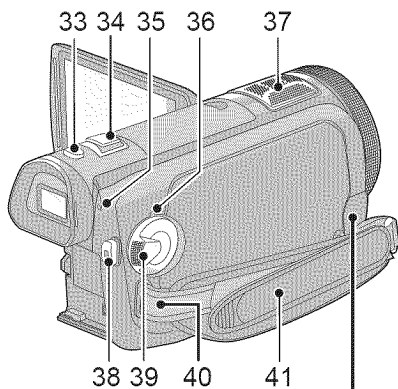

32 Tripod receptacle



- 33 Photoshot button [] (→ 37)
 34 Zoom lever [W/T] (In Motion Picture Recording Mode or Still Picture Recording Mode) (→ 55)
 Thumbnail display switch [ / ]
 Volume lever [-VOL+] (In Playback Mode) (→ 43)
 35 HDD access lamp [ACCESS HDD]
 36 Status indicator (→ 29)
 37 Internal microphones
 38 Recording start/stop button (→ 35)
 39 Mode dial (→ 30)
 40 Shoulder strap fixture
 41 Grip belt
 Adjust the length of the grip belt so that it fits your hand.

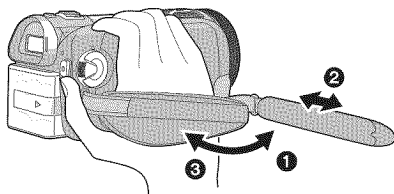
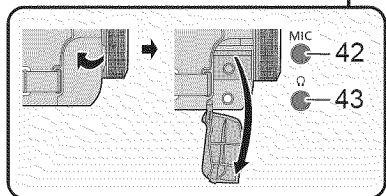

- ❶ Flip the belt.
 - ❷ Adjust the length.
 - ❸ Replace the belt.
- 42 Microphone terminal [MIC]**
- A compatible plug-in powered microphone can be used as an external microphone.
 - Audio will be stereo (2 ch) with the external microphone input.
 - When the unit is connected with the AC adaptor, sometimes noise may be heard depending on the microphone type. In this case, please switch to the battery for the power supply and the noise will stop.
- 43 Headphone terminal [] (→ 64)**

1

Power supply

■ About batteries that you can use with this unit

The battery that can be used with this unit is VW-VBG130/VW-VBG260/VW-VBG6.

- This unit has a function to distinguish the batteries that can be used, and the batteries (VW-VBG130/VW-VBG260/VW-VBG6) that are compatible with this function. (The batteries that are not compatible with this function cannot be used.)
- To use the VW-VBG6 for this unit, the battery pack holder kit VW-VH04 (optional) is required.

It has been found that counterfeit battery packs which look very similar to the genuine product are made available to purchase in some markets. Some of these battery packs are not adequately protected with internal protection to meet the requirements of appropriate safety standards. There is a possibility that these battery packs may lead to fire or explosion. Please be advised that we are not liable for any accident or failure occurring as a result of use of a counterfeit battery pack. To ensure that safe products are used we would recommend that a genuine Panasonic battery pack is used.

Charging the battery

When this unit is purchased, the battery is not charged. Charge the battery before using this unit for the first time.

Important:

If the DC cable is connected to the AC adaptor, then the battery will not charge. Remove the DC cable from the AC adaptor.

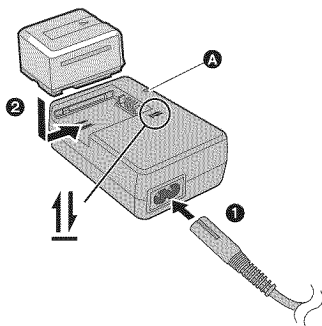

Charging lamp

[CHARGE] A

Lights up:

Charging (Battery charging time: → 24)

Goes off:

Charging completed

Flashing:

Be sure to connect the unit correctly. (→ 143)

- 1 Connect the AC cable to the AC adaptor and the AC outlet.
- 2 Insert the battery into the AC adaptor by aligning the arrows.

- We recommend using Panasonic batteries (→ 12, 24, 25, 155).
- If you use other batteries, we cannot guarantee the quality of this product.
- Do not heat or expose to flame.
- Do not leave the battery(ies) in an automobile exposed to direct sunlight for a long period of time with doors and windows closed.

Inserting/removing the battery

Install the battery by inserting it in the direction shown in the figure.

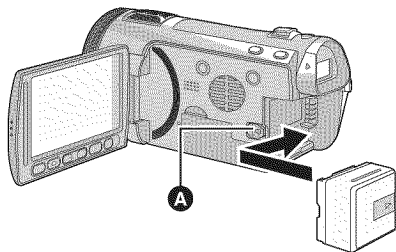

- A** Insert the battery until it clicks and locks.

Removing the battery

Be sure to hold down the power button until the status indicator goes off. Then remove the battery while supporting the unit to prevent it from dropping.

Move the battery release lever in the direction indicated by the arrow and remove the battery when unlocked.

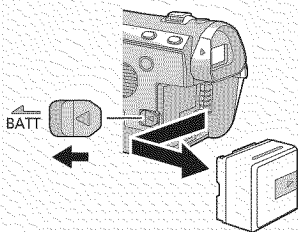

CAUTION

Danger of explosion if battery is incorrectly replaced. Replace only with the same or equivalent type recommended by the manufacturer. Dispose of used batteries according to the manufacturer's instructions.

Charging and recording time

■ Charging/Recording time

- Temperature: 25 °C (77 °F)/humidity: 60%

HDC-TM700				
Battery model number [Voltage/Capacity (minimum)]	Charging time	Recording mode	Maximum continuous recordable time	Actual recordable time
Supplied battery/ VW-VBG130 (optional) [7.2 V/1250 mAh]	2 h 35 min	1080/60p	1 h 35 min	55 min
		HA, HG, HX, HE	1 h 40 min	1 h
VW-VBG260 (optional) [7.2 V/2500 mAh]	4 h 40 min	1080/60p	3 h	1 h 50 min
		HA, HG, HX, HE	3 h 10 min	1 h 55 min
VW-VBG6 (optional)* [7.2 V/5400 mAh]	9 h 25 min	1080/60p	7 h 30 min	4 h 40 min
		HA, HG, HX	7 h 50 min	4 h 50 min
		HE	7 h 55 min	4 h 55 min

HDC-HS700

Battery model number [Voltage/Capacity (minimum)]	Charging time	Recording destination	Recording mode	Maximum continuous recordable time	Actual recordable time
Supplied battery/ VW-VBG130 (optional) [7.2 V/1250 mAh]	2 h 35 min	HDD	1080/60p	1 h 25 min	55 min
			HA, HG, HX, HE	1 h 30 min	
		SD	1080/60p, HA, HG	1 h 30 min	55 min
			HX, HE	1 h 35 min	
VW-VBG260 (optional) [7.2 V/2500 mAh]	4 h 40 min	HDD	1080/60p	2 h 50 min	1 h 45 min
			HA, HG	2 h 55 min	
			HX, HE	2 h 55 min	
		SD	1080/60p	2 h 50 min	1 h 45 min
			HA, HG, HX, HE	3 h	1 h 50 min
VW-VBG6 (optional)* [7.2 V/5400 mAh]	9 h 25 min	HDD	1080/60p	7 h	4 h 20 min
			HA, HG, HX	7 h 15 min	4 h 30 min
			HE	7 h 20 min	
		SD	1080/60p	7 h 10 min	4 h 25 min
			HA, HG	7 h 25 min	4 h 35 min
			HX	7 h 30 min	
			HE	7 h 30 min	

* The battery pack holder kit VW-VH04 (optional) is necessary.



- These times are approximations.
- **The indicated charging time is for when the battery has been discharged completely. Charging time and recordable time vary depending on the usage conditions such as high/low temperature.**

- The actual recordable time refers to the recordable time when repeatedly starting/stopping recording, turning the unit on/off, moving the zoom lever etc.
- The batteries heat up after use or charging. This is not a malfunction.

Battery capacity indication

- The display changes as the battery capacity reduces.



If there is less than 3 minutes remaining, then  will become red. If the battery discharges, then  will flash.

- The remaining battery capacity is displayed when using the Panasonic battery that you can use for this unit. The actual time can vary depending on your actual use.
- If the actual remaining time exceeds 9 hours 59 minutes, the indication will stay green and will not change until the remaining time falls below 9 hours 59 minutes.
- When using the AC adaptor or batteries made by other companies, the remaining battery capacity will not be shown.

Connecting to the AC outlet

Important:

While the DC cable is connected to the AC adaptor, the battery will not charge.

- Do not use the AC cable with any other equipment as it is designed only for this unit. Also, do not use the AC cable from other equipment with this unit.

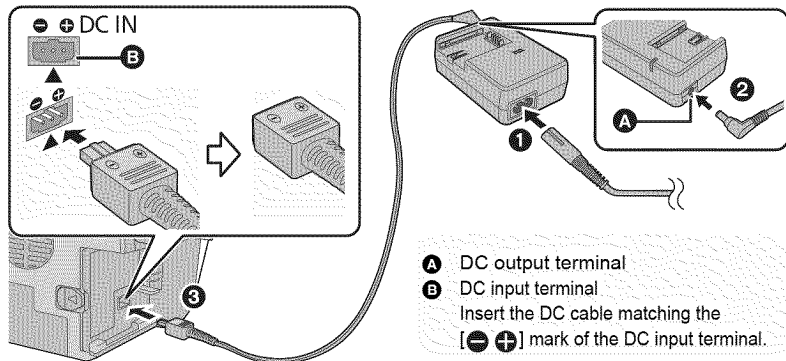

- 1** Connect the AC cable to the AC adaptor and the AC outlet.
- 2** Connect the DC cable to the AC adaptor.
- 3** Connect the DC cable to the DC input terminal [DC IN].

- When removing the AC adaptor, be sure to hold down the power button until the status indicator goes off. Then remove the AC adaptor.

Recording to a card

The unit can record still pictures or motion pictures to an SD card, built-in memory or HDD. To record to an SD card, read the following.

This unit (an SDXC compatible device) is compatible with SD Memory Cards, SDHC Memory Cards and SDXC Memory Cards. When using an SDHC memory card/SDXC memory card with other equipment, check the equipment is compatible with these memory cards.

Cards that you can use with this unit

Use SD cards conforming to Class 4 or higher of the SD Speed Class Rating* for motion picture recording.

Card type	Capacity	Motion picture recording	Still picture recording
SD Memory Card	8 MB/16 MB	Cannot be used.	Can be used.
	32 MB/64 MB/ 128 MB/256 MB	Cannot be guaranteed in operation. The recording may suddenly stop during motion picture recording depending on the SD card you use. (→ 136)	
	512 MB/1 GB/ 2 GB	Can be used.	
SDHC Memory Card	4 GB/6 GB/8 GB/ 12 GB/16 GB/ 24 GB/32 GB		
SDXC Memory Card	48 GB/64 GB		

* The SD Speed Class Rating is the speed standard for successive writes.

- 4 GB or more Memory Cards that do not have the SDHC logo or 48 GB or more Memory Cards that do not have the SDXC logo are not based on SD Memory Card Specifications.
- When the write-protect switch **A** on SD card is locked, no recording, deletion or editing will be possible on the card.
- Keep the Memory Card out of reach of children to prevent swallowing.

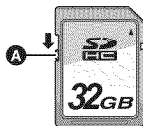

Inserting/removing an SD card

When using an SD card not from Panasonic, or one previously used on other equipment, for the first time on this unit, format the SD card. (→ 51) When the SD card is formatted, all of the recorded data is deleted. Once the data is deleted, it cannot be restored.

Caution:

Check that the access lamp has gone off.

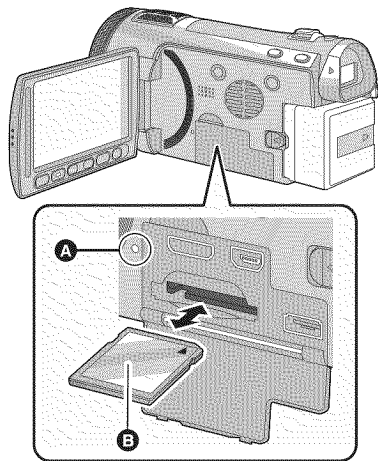

Access lamp [ACCESS] **A**

- When this unit is accessing the SD card or built-in memory, the access lamp lights up.

- 1** Open the LCD monitor.
- 2** Open the SD card/terminal cover and insert (remove) the SD card into (from) the card slot.

- Face the label side **B** in the direction shown in the illustration and press it straight in as far as it will go.
- Press the center of the SD card and then pull it straight out.

- 3** Securely close the SD card/terminal cover.

- Securely close it until it clicks.

- Do not touch the terminals on the back of the SD card.
- Do not apply strong shocks, bend, or drop the SD card.
- Electrical noise, static electricity or the failure of this unit or the SD card may damage or erase the data stored on the SD card.
- When the card access lamp is lit, do not:
 - Remove the SD card
 - Turn the unit off
 - Insert and remove the USB cable
 - Expose the unit to vibrations or shockPerforming the above while the lamp is on may result in damage to data/SD card or this unit.
- Do not expose the terminals of the SD card to water, garbage or dust.
- Do not place SD cards in the following areas:
 - In direct sunlight.
 - In very dusty or humid areas.
 - Near a heater.
 - Locations susceptible to significant difference in temperature (condensation can occur).
 - Where static electricity or electromagnetic waves occur.
- To protect SD cards, return them to their cases when you are not using them.
- About disposing of or giving away the SD card. (→ 144)

3

Turning the unit on/off

You can turn the power on and off using the power button, the LCD monitor or the viewfinder.

Turning the power on and off with the power button

Press the power button to turn on the power

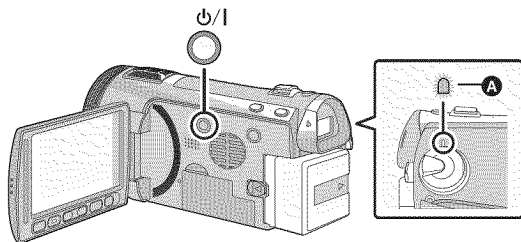

To turn off the power

Hold down the power button until the status indicator goes off.

A The status indicator lights on.

Turning the power on and off with the LCD monitor/viewfinder

Opening the LCD monitor or extending the viewfinder turns on the power. Closing the LCD monitor/viewfinder turns off the power.

During general use, you may find it convenient to turn the power on/off using the LCD monitor or viewfinder.

■ To turn on the power

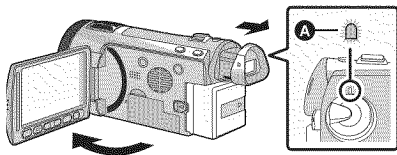

A The status indicator lights on.

■ To turn off the power

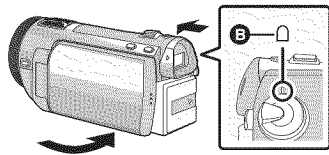



B The status indicator goes off.

- The power will not turn off unless the LCD monitor is closed and the viewfinder is retracted.
- The power will not turn off while recording motion pictures even if the LCD monitor is closed and the viewfinder is retracted.
- In the following cases, opening the LCD monitor or extending the viewfinder does not turn on the power. Press the power button to turn on the power.
 - When the unit is originally purchased
 - When you have turned off the power using the power button



4

Selecting a mode

Change the mode to recording or playback.

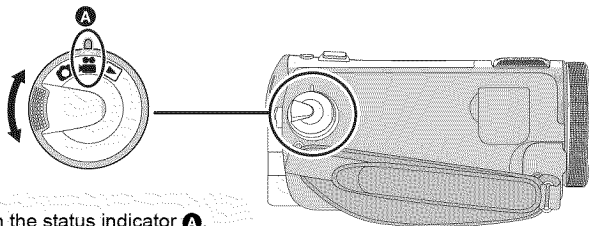
Operate the mode dial to change the mode to  ,  or  .



	Motion Picture Recording Mode (→ 35)
	Still Picture Recording Mode (→ 37)
	Playback Mode (→ 41, 86)

Adjusting LCD monitor/ viewfinder

How to use the touch screen

You can operate by directly touching the LCD monitor (touch screen) with your finger. It is easier to use the stylus pen (supplied) for detailed operation or if it is hard to operate with your fingers.

■ Touch

Touch and release the touch screen to select icon or picture.

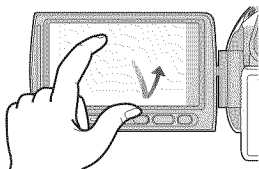

- Touch the center of the icon.
- Touching the touch screen will not operate while you are touching another part of the touch screen.

■ About the operation icons

▲ / ▼ / ◀ / ▶ :

These icons are used to switch the menu and thumbnail display page, for item selection and setting etc.

↶ :

Touch to return to the previous screen such as when setting menus.

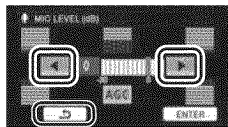

- Do not touch on the LCD monitor with hard pointed tips, such as ball point pens.
- Perform the touch screen calibration when the touch is not recognized or wrong location is recognized. (→ 51)

Viewfinder adjustment

■ Adjusting the field of view

It adjusts the field of view to show the images on the viewfinder clearly.

Adjust the focus by rotating the eyepiece corrector dial.

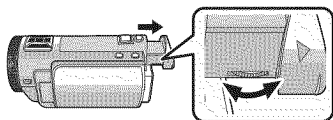

- Extend the viewfinder and close the LCD monitor to turn on the viewfinder.

Recording showing the contents to a partner

◇ Change the mode to or .

Extend the viewfinder and rotate the LCD monitor towards the lens side.

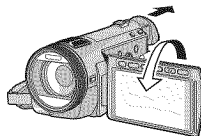



- LCD monitor and viewfinder are turned on during the face-to-face recording when the viewfinder is extended.
 - The image is horizontally flipped as if you see a mirror image. (However the image recorded is the same as a normal recording.)
 - Record by viewing the image in the viewfinder during the face-to-face recording.
-
- Only some indications will appear on the screen. When appears, return the direction of the LCD monitor to normal position and check the warning/alarm indication. (→ 133)

Setting date and time

When the unit is turned on for the first time, a message asking you to set the date and time will appear.

Select [YES] and perform steps 2 to 3 below to set the date and time.

◇ Change the mode to  or .

1 Select the menu.

 : [SETUP] → [CLOCK SET]

2 Touch the date or time to be set, then set the desired value using / .



A Displaying the World time setting (→ 46):

 [HOME] /  [DESTINATION]

- The year can be set between 2000 and 2039.
- The 12-hour system is used to display the time.

3 Touch [ENTER].

- The clock function starts at [00] seconds.
- A message prompting for World time setting may be displayed. Perform the World time setting by touching the screen. (→ 46)
- Touch [EXIT] or press the MENU button to complete the setting.

- The date and time function is driven by a built-in lithium battery.
- When this unit is purchased, the clock is set. If the time display becomes [- -], the built-in lithium battery needs to be recharged. To recharge the built-in lithium battery, connect the AC adaptor or attach the battery to this unit. Leave the unit as it is for approx. 24 hours and the battery will maintain the date and time for approx. 6 months. (The battery is still being recharged even if the power is off.)

1

Before recording

■ Basic camera positioning

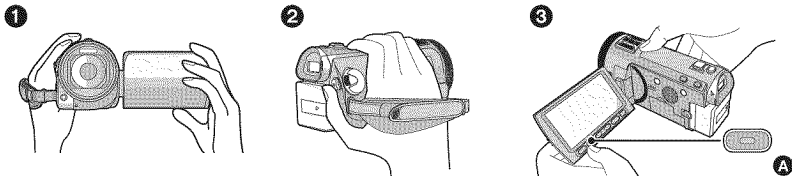

- ① Hold the unit with both hands.
 - ② Put your hand through the grip belt.
 - ③ It is convenient to use the Sub-recording Start/Stop button **A** when holding the unit at waist level.
- When recording, make sure your footing is stable and there is no danger of colliding with another person or object.
 - When you are outdoors, record pictures with the sunlight behind you. If the subject is backlit, it will become dark in the recording.
 - Keep your arms near your body and separate your legs for better balance.
 - Do not cover the microphones or the cooling fan inlet with your hand etc.

■ Basic motion picture recording

- The unit should normally be held steady when recording.
- If you move the unit when recording, do so slowly, maintaining a constant speed.
- The zoom operation is useful for recording subjects you cannot get close to, but overuse of zoom in and zoom out can make the resulting motion picture less enjoyable to watch.

■ Attaching/Removing the lens hood

This will reduce the extra light entering the lens in bright sunlight or backlight etc., making it possible to take clearer pictures.

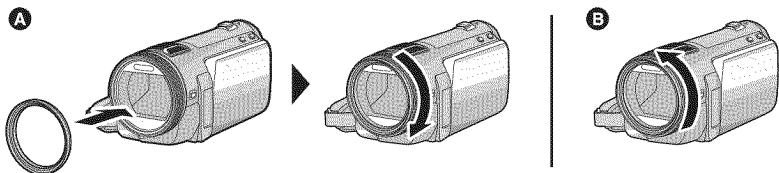



- A** Attaching the lens hood
 - B** Removing the lens hood
- If you use the Filter kit (optional) or the conversion lens (optional), remove the lens hood.

2

Selecting a media to record

The card, built-in memory, and HDD media can be selected separately to record motion pictures or still pictures.

- 1 Change the mode to  or .
- 2 Select the menu.

 : [MEDIA SELECT]

- 3 Touch the media to record motion pictures or still pictures.

HDC-TM700

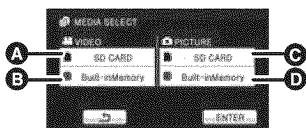

- A [VIDEO/SD CARD]
- B [VIDEO/Built-inMemory]
- C [PICTURE/SD CARD]
- D [PICTURE/Built-inMemory]

HDC-HS700



- E [VIDEO/SD CARD]
- F [VIDEO/HDD]
- G [PICTURE/SD CARD]
- H [PICTURE/HDD]

- The media is selected separately to motion pictures or still pictures is highlighted in yellow.



- 4 Touch [ENTER].

3

Recording motion
pictures

VIDEO

- 1 Change the mode to .
- 2 Open the LCD monitor or extend the viewfinder.
- 3 Press the recording start/stop button to start recording.

B When you begin recording,  changes to .

- 4 Press the recording start/stop button again to pause recording.

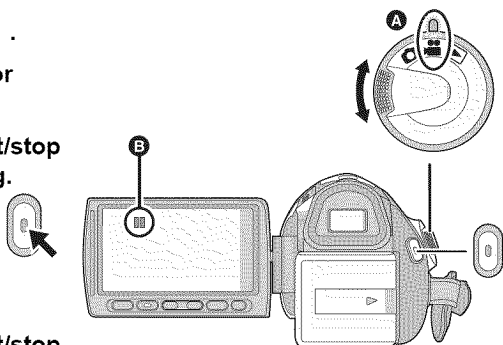

• Align with the status indicator **A**.

- Still pictures can be recorded while recording the motion picture. (→ 38)
- The images recorded between pressing the recording start/stop button to start recording and pressing it again to pause recording become one scene.
- Maximum number of recordable scenes: 3900
Maximum number of different dates: 200 (→ 90)
When either of them reaches to the maximum limit, additional scenes cannot be recorded. (In the case of SD cards it is the maximum number of recordable scenes per card.)
- While recording is in progress, the recording will not stop even if the LCD monitor is closed and the viewfinder is retracted.
- Put the unit in Pause mode when connecting or disconnecting an external microphone with the MIC terminal.

■ Screen indications in the Motion Picture Recording Mode



- A Recording mode**
- B Remaining time left for recording**
(When the remaining time is less than 1 minute, [R 0h00m] flashes red.)
- C Recording time elapsed**
Each time the unit is put into recording pause, the counter display will be reset to "0h00m00s".

About the compatibility of the recorded motion pictures



Please refer to page 58 about 1080/60p

- They are not compatible with devices other than those that support AVCHD. Images cannot be played with equipment that does not support AVCHD (ordinary DVD recorders). Confirm that your equipment supports AVCHD by referring to the operating instructions.
- There are some cases where the recorded motion pictures cannot be played back, even if the device supports AVCHD. In such cases, play the recorded motion picture with this unit instead.

4

Recording still pictures

PHOTO

- 1 Change the mode to .
- 2 Open the LCD monitor or extend the viewfinder.
- 3 Press the  button halfway.
(For Auto focus only)



- 4 Press the  button fully.

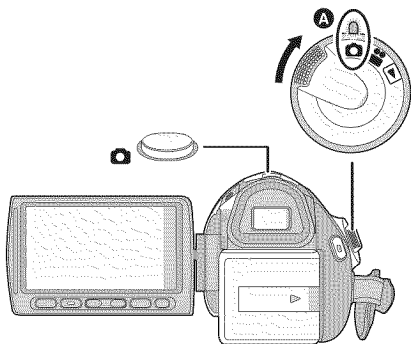



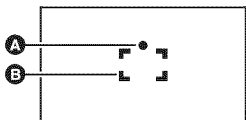

- Align with the status indicator **A**.

Focus indication:











- A** Focus indication
 - (The white lamp flashes.):
Focusing
 - (The green lamp lights up.):
When in focus
 - No mark:
When focusing is unsuccessful.
- B** Focus area (area inside brackets)

- If you set the Optical image stabilizer function (→ 56) to  /  (MODE1), then the Image Stabilizer function will be more effective. () (MEGA Optical Image Stabilizer) will be displayed when the  button is pressed halfway.)
- The AF assist lamp lights in dark places.
- Focus indication will change to registered focus icon when [FACE RECOG.] is set to [ON]. (→ 70)
- Using a flash or tripod is recommended when recording still pictures in dark places because the shutter speed becomes slow.
- The screen will become darker when the  button is pressed halfway if the shutter speed is 1/30 or slower.

■ About the screen indications in Still Picture Recording



-  : Still picture operation indicator (→ 131)
-  : Flash (→ 61)
-  : Flash level (→ 61)
-  : Red-eye reduction (→ 62)
-  : MEGA optical image stabilizer (→ 37)
-  : Optical image stabilizer (→ 56)
-  : Quality of still pictures (→ 79)
-  : Size of still pictures (→ 78)
- R3000: Remaining number of still pictures (Flashes in red when [0] appears.)
- AF*: AF assist lamp (→ 81)

■ About the focus indication

- The focus indication indicates the status of the Auto focus.
- The focus indication does not appear in Manual Focus Mode.
- The focus indication does not appear or has difficulty focusing in the following cases.
 - When close subjects and far subjects are included in the same scene.
 - When the scene is dark.
 - When there is a bright part in the scene.
 - When the scene is filled with only horizontal lines.

■ About the focusing area

When there is a contrasting object ahead or behind the subject in the focus area, the subject may not be focused. If so, move the contrasting object out of the focus area.

- Focus area is not displayed in the following conditions.
 - When the Intelligent Auto Mode (Portrait) is used.
 - When a zoom magnification of more than approx. 12× is used.
 - When AF/AE tracking is used.
 - When the Extra optical zoom is used.
 - When the unit determines that the AF assist lamp is necessary.

Recording still pictures in Motion Picture Recording Mode

You can record still pictures even in Motion Picture Recording Mode.

◇ Change the mode to  .

Press the  button fully (press to the bottom) to take the picture.



- It is possible to record still pictures while recording motion pictures. (Simultaneous recording)
-
- Built-in flash, Red-eye reduction, Self-timer (→ 59) do not work.
 - While recording motion pictures or during the PRE-REC operation, the following arrangements are applied so that motion picture recording takes preference over still picture recording.
 - Image quality is different from ordinary still pictures.
 - The remaining usable capacity (number of pictures that can be taken) indication does not appear.

Intelligent Auto Mode

VIDEO PHOTO

The following modes appropriate for the condition are set just by pointing the unit to what you want to record.

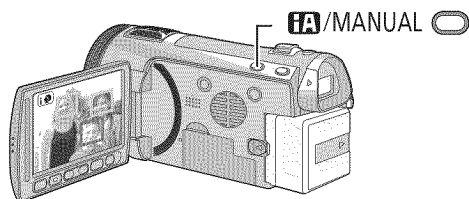

Intelligent auto/Manual button

Press this button to switch Intelligent Auto Mode/Manual Mode.

- Please refer to page 82 for details about Manual Mode.

Mode	Scene	Effect
Portrait	When the object is a person	Faces are detected and focused automatically, and the brightness is adjusted so it is recorded clearly.
Scenery	Recording outdoors	The whole landscape will be recorded vividly without whitening out the background sky, which may be very bright.
Spotlight ^{*1}	Under a spotlight	Very bright object is recorded clearly.
Low light ^{*1}	Dark room or twilight	It can record very clearly even in a dark room or twilight.
Night portrait ^{*2}	Recording night portrait	A subject and the background are recorded with near real-life brightness.
Night scenery ^{*2}	Recording night scenery	You can record night scenery vividly by slowing the shutter speed.
Macro ^{*2}	Recording zooming in on a flower etc.	This allows recording at very close proximity to the object of recording.
Normal	Other situations	Contrast is adjusted automatically for clear images.

*1 In Motion Picture Recording Mode only

*2 In Still Picture Recording Mode only

- Depending on the recording conditions, the unit may not enter the desired mode.
- In the Portrait mode, a subject that is bigger and close to center of the screen will be surrounded by an orange frame. (→ 71)
- Using a tripod is recommended in Night Portrait and Night Scenery Mode.

- Optical Image Stabilizer function (→ 56) is set to Active Mode/ON in all modes.
- Faces cannot be detected depending on the recording conditions, such as when faces are of certain sizes or at certain tilts or when digital zoom is used.
- The microphone setup is set to surround in the Intelligent Auto Mode. (→ 73)

■ Intelligent Auto Mode

When switching to Intelligent Auto Mode, the Auto White Balance and Auto Focus operate and automatically adjust the color balance and focusing.

Depending on the brightness of the subject etc., the aperture and shutter speed are automatically adjusted for an optimum brightness.

- Color balance and focus may not be adjusted automatically depending on light sources or scenes. If so, manually adjust these settings. (→ 83, 85)

Automatic white balance

The illustration shows the range over which Automatic white balance functions.

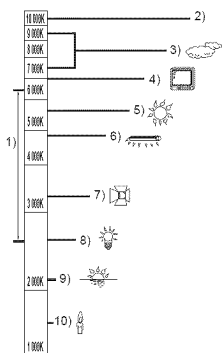

- 1) The effective range of Automatic white balance adjustment on this unit
- 2) Blue sky
- 3) Cloudy sky (rain)
- 4) TV screen
- 5) Sunlight
- 6) White fluorescent lamp
- 7) Halogen light bulb
- 8) Incandescent light bulb
- 9) Sunrise or sunset
- 10) Candlelight

If the automatic white balance is not functioning normally, adjust the white balance manually. (→ 83)

Auto focus

The unit focuses automatically.

- Auto focus does not work correctly in the following situations. Record pictures in the Manual Focus Mode. (→ 85)
 - Recording distant and close-up objects at the same time
 - Recording a subject behind a dirty or dusty window
 - Recording a subject that is surrounded by objects with glossy surfaces or by highly reflective objects

For details on Scene Mode, refer to page 65.

For how to set Manual Focus/White Balance manually, refer to page 82-85.

Motion picture/Still
picture playback

VIDEO | PHOTO

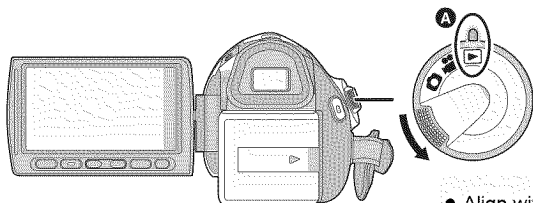

- Align with the status indicator **A**.

1 Change the mode to .

2 Touch the play mode select icon **B**.

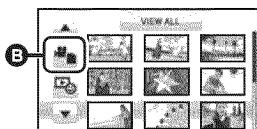

3 Touch the desired media to be played back motion pictures or still pictures.

HDC-TM700

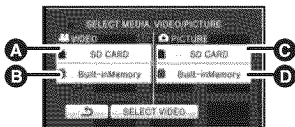

- A** [VIDEO/SD CARD]
- B** [VIDEO/Built-inMemory]
- C** [PICTURE/SD CARD]
- D** [PICTURE/Built-inMemory]

HDC-HS700

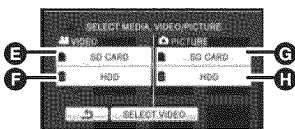

- E** [VIDEO/SD CARD]
- F** [VIDEO/HDD]
- G** [PICTURE/SD CARD]
- H** [PICTURE/HDD]

4 Touch the scene or the still picture to be played back.



- Next (previous) page can be displayed by touching











5 Select the playback operation by touching the operation icon.



A Operation icon

- Touch  /  to display/not-display the operation icon.

Motion picture playback	Still picture playback
<p>: Playback/Pause</p> <p>: Rewind playback</p> <p>: Fast forward playback</p> <p>: Stops the playback and shows the thumbnails.</p> <p>: Displays the direct playback bar. (→ 87)</p>	<p>: Slide show (playback of the still pictures in numerical order) start/pause.</p> <p>: Plays back the previous picture.</p> <p>: Plays back the next picture.</p> <p>: Stops the playback and shows the thumbnails.</p>

■ Play back 1080/60p recorded scenes (→ 58)

- Change the mode to  and touch the play mode select icon.

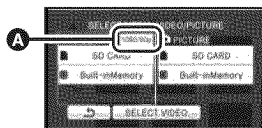

Touch [SELECT VIDEO].

- The motion picture media switches between normal and 1080/60p recorded scenes each time [SELECT VIDEO] is touched.



A 1080/60p appears.

Change the thumbnail display

While the thumbnail is displayed, the thumbnail display changes in the following order if the zoom lever or adjust zoom buttons are operated to  side or  side.

20 scenes \longleftrightarrow 9 scenes \longleftrightarrow 1 scene
 \longleftrightarrow Highlight&Time frame index* (\rightarrow 88)

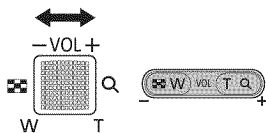

* Highlight&Time frame index can only set in Motion Picture Playback Mode.

- 9 scenes display returns if the power is turned off or the mode is changed.
- When the thumbnail display is changed to 1 scene during motion picture playback, the recording date and time can be checked. Similarly, when the thumbnail display is changed to 1 still picture during still picture playback, the recording date and file number can be checked.

Speaker/Headphone volume adjustment

Operate the volume lever or the adjust zoom buttons to adjust the speaker/headphone volume during motion picture playback.

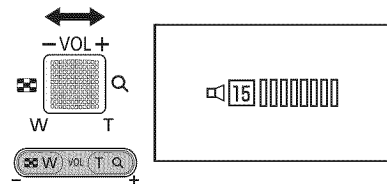

Towards “+”:
Increases the volume

Towards “-”:
Decreases the volume

- Sound will be heard only during normal playback.
- If pause play is continued for 5 minutes, the screen returns to the thumbnails.
- The elapsed time for playback indication will be reset to “0h00m00s” for each scene.

Motion picture compatibility

- This unit is based on the AVCHD format.
- The video signal that can be played back on this unit is 1920×1080/60i, 1920×1080/24p or 1440×1080/60i.
- This unit may degrade or not play back motion pictures recorded or created on other products, and other products may degrade or not play back motion pictures recorded on this unit, even if the products support AVCHD.

Please refer to page 58 about 1080/60p.

Still picture compatibility

- This unit is compliant with the unified standard DCF (Design rule for Camera File system) established by JEITA (Japan Electronics and Information Technology Industries Association).
- The file format of still pictures supported by this unit is JPEG. (Not all JPEG formatted files will be played back.)
- This unit may degrade or not play back still pictures recorded or created on other products and other products may degrade or not play back still pictures recorded on this unit.

1

Using the menu screen

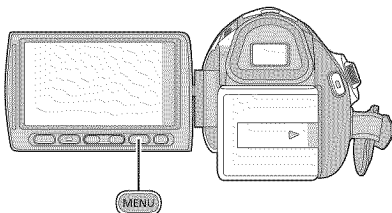

1 Press the MENU button.



2 Touch the top menu **A**.

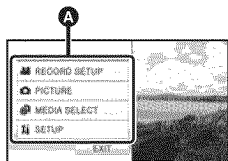

3 Touch the submenu **B**.

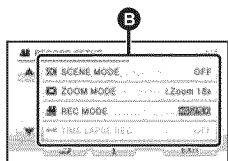

- Next (previous) page can be displayed by touching / .

4 Touch the desired item to enter the setting.

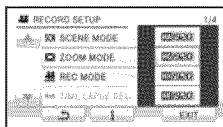

5 Touch [EXIT] or press the MENU button to exit the menu setting.

■ About guide display

After touching , touching the submenus and items will cause function descriptions and settings confirmation messages to appear.

- After the messages have been displayed, the guide display is canceled.

Using the quick menu

This allows quick setting of some of the menus.

1 Press the Q.MENU button.



The following menus can be set.

Touch the desired menu.

- The items displayed differ depending on the position of the mode dial or settings.

Icon	Function	Page
	[REC MODE]	→ 66
	[TIME LAPSE REC]	→ 67
	[PICTURE SIZE]	→ 78
	[DISPLAY]	→ 46
	[POWER LCD]	→ 49
	[GUIDE LINES]	→ 63
	[MIC LEVEL]	→ 74
	[MF ASSIST]	→ 85
	[ZEBRA]	→ 76
	[LUMINANCE]	→ 76
	[HISTOGRAM]	→ 77

2 Touch the desired item to enter the setting.

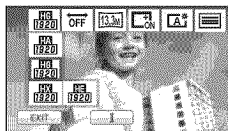

3 Touch [EXIT] or press Q.MENU button to exit the quick menu.

2

Using the Setup Menu

- The items displayed differ depending on the position or settings of the mode dial.
Select the menu.

[MENU] : [SETUP] → desired setting

[DISPLAY] [OFF]/[ON]

The screen indications are selected as shown in the illustration.

- It is possible to set from the quick menu.
(→ 45)

[OFF]

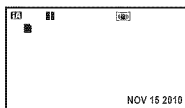

[ON]

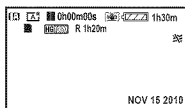

[CLOCK SET]

Please refer to page 32.

[SET WORLD TIME]

It is possible to display and record the time at the travel destination by selecting your home region and the travel destination.

1 Touch [SET WORLD TIME].

- If the clock is not set, adjust the clock to the current time. (→ 32)
- When the [HOME] (your home region) is not set, the message appears. Touch [ENTER] and proceed to Step 3.

2 (Only when setting your home region)

Touch [HOME].

- Touch [ENTER].

3 (Only when setting your home region)

Touch **[←]/[→]** to select your home region and touch [ENTER].

- Touch [SUMMER TIME SET] to set daylight saving time. **[☀]** appears and the summer time setting is turned on; the time difference from GMT is set forward by one hour. Touch [SUMMER TIME SET] again to return to the normal time setting.

4 (Only when setting the region of your travel destination)

Touch [DESTINATION].

- Touch [ENTER].



- A** The current time
- B** The time difference from GMT (Greenwich Mean Time)

- When the home region is set for the first time, the screen for selecting home/travel destination appears after setting the home region successively. If the home region has already been set once, execute the menu operation for Step 1.

- 5 (Only when setting the region of your travel destination)
Touch / to select your travel destination and touch [ENTER].



- Touch [SUMMER TIME SET] to set daylight saving time. appears and the summer time setting is turned on. The clock and time difference from the home region time are set forward by one hour. Touch [SUMMER TIME SET] again to return to the normal time setting.
- Close the setting by pressing the MENU button. appears and the time of the travel destination is indicated.

- C The local time at the selected travel destination
- D The time difference between the travel destination and the home region

To return the display to the home setting

Set the home region using Step 1 to 3, and close the setting by touching [EXIT] or pressing the MENU button.

- If you cannot find your travel destination in the area shown on the screen, set it by using the time difference from your home region.

[DATE/TIME] [OFF]/[D/T]/[DATE]

It is possible to change the date and time display mode.

- You can also show or change the date and time display by repeatedly pressing the DATE/TIME button on the remote control.

[DATE FORMAT] [Y/M/D]/[M/D/Y]/[D/M/Y]

It is possible to change the date format.

[ECONOMY] [OFF]/[5 MINUTES]

When about 5 minutes have passed without any operation, this unit automatically turns off to save battery life.

- The Power Save function will not activate when:
 - connected to AC adaptor
 - using the USB cable for PC, DVD burner etc.
 - PRE-REC is used

[QUICK POWER ON] [OFF]/[ON]

The unit is put into recording pause approx. 1 second when the power is turned on with the mode set to or .

- Depending on the recording conditions, start time may be longer than 1 second in Still Picture Recording Mode.
- In the Quick power on mode, the zoom magnification becomes 1×.

This unit is put into recording pause approx. 0.6 seconds after the LCD monitor is reopened or the viewfinder is extended.

- When in Quick start standby mode about 80% of the power used in Recording pause mode is being consumed, so the recording time will be reduced.
- Start time will not be shortened if there is no SD card inserted.



[HDC-TM700]

Start time will be shortened if the [Built-inMemory] is selected in the [MEDIA SELECT], even if there is no SD card inserted.

[HDC-HS700]

Start time will be shortened if the [HDD] is selected in the [MEDIA SELECT], even if there is no SD card inserted.

- Change the mode to  or .

- 1 Set [QUICK START] to [ON].
- 2 Close the LCD monitor and retract the viewfinder while the mode is set to  or .

The status indicator **A** flashes green and the unit goes into Quick start standby mode.

- The lens cover does not close.

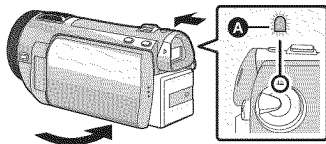

- 3 Open the LCD monitor or extend the viewfinder.

The status indicator **A** lights red and the unit is put into recording pause.

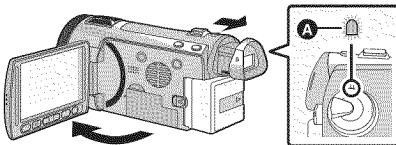

- Quick Start Standby Mode is canceled if
 - about 5 minutes have elapsed
 - mode is set to 
- Time for Quick start will be more than 0.6 seconds slower when the Digital cinema is used.
- Depending on the recording conditions, time for Quick Start may be more than 0.6 seconds slower in Still Picture Recording Mode.
- It may take some time for Automatic white balance to adjust.
- In the Quick Start Mode, the zoom magnification becomes 1×.
- If [ECONOMY] (→ 47) is set to [5 MINUTES] and the unit automatically goes into Quick Start Standby Mode, close the LCD monitor and viewfinder and then open the LCD monitor or extend the viewfinder again.
- Turn the unit off using the power button.
- Quick start standby mode cannot be released by the remote control.

Please refer to page 53.

[REC LAMP]

[OFF]/[ON]

The recording lamp lights up during recording and flashes when the unit receives a signal from the remote control or when the Self-timer is counting down. When this is set to [OFF], it does not light during recording.

[ALERT SOUND]

[OFF]/ [v] / [v]]

Touch screen operation, starting and stopping of recording and power on/off can be confirmed with this sound.

[v] (Volume low)/ [v]] (Volume high)

2 Beeps for 4 times

When an error occurs. Check the sentence displayed on the screen. (→ 133)

[POWER LCD]

[+2]* / [+1]* / [0]* / [-1]* / [A]*

This makes it easier to view the LCD monitor in bright places including outdoors.

- These settings will not affect the images actually recorded.
- It is possible to set from the quick menu. (→ 45)

[+2]* (Makes even brighter) / [+1]* (Makes brighter) / [0]* (Normal) / [-1]* (Makes less bright) / [A]* (Automatic adjustment)

* It is not displayed in the Manual Mode or in the Playback Mode.

- When the AC adaptor is in use, the LCD monitor is set to [+1]* automatically.
- The recordable time will become shorter when you use this unit with the LCD monitor lit up.

[LCD SET]

It adjusts brightness and color density on the LCD monitor.

- These settings will not affect the images actually recorded.

1 Touch [LCD SET].

2 Touch the desired setting item.

[BRIGHTNESS]:

Brightness of the LCD monitor

[COLOR]:

Color level of the LCD monitor

3 Touch [◀]/[▶] to adjust settings.

4 Touch [ENTER].

- Touch [EXIT] or press the MENU button to exit the menu screen.

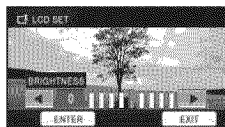

[EVF SET]



It adjusts the brightness of the viewfinder.

- These settings will not affect the images actually recorded.

1 **Extend the viewfinder and open the LCD monitor.**

2 **Touch [EVF SET].**

- The viewfinder turns on.

3 **Touch  / ** to adjust the setting.

- Adjust while checking the picture in the viewfinder.

4 **Touch [ENTER].**

- Touch [EXIT] or press the MENU button to complete the setting.

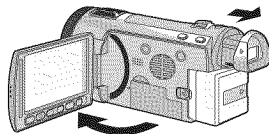

[AV MULTI]

[COMPONENT]/[AV OUT]

Please refer to page 104.

[COMPONENT OUT]

[480i]/[1080i]

Please refer to page 104.

[HDMI RESOLUTION]

[AUTO]/[1080p]/[1080i]/[480p]

Please refer to page 104.

[VIERA Link]

[OFF]/[ON]

Please refer to page 105.

[TV ASPECT]

[16:9]/[4:3]

Please refer to page 103.

[INITIAL SET]

Set to [YES] for changing the menu settings back to the default condition.

- Settings for [CLOCK SET], [MEDIA SELECT] and [LANGUAGE] will not be changed.

[FORMAT MEDIA]

Please be aware that if a medium is formatted, then all the data recorded on the medium will be erased and cannot be restored. Back up important data on a PC, DVD disc etc. (→ 109, 117)

1 Touch [FORMAT MEDIA].

2 [HDC-TM700]

Touch [SD CARD] or
[Built-inMemory].

[HDC-HS700]

Touch [SD CARD] or [HDD].

- When formatting is complete, touch [EXIT] to exit the message screen.
 - Perform a physical formatting of the SD card when the SD card is to be disposed/transferred. (→ 144)
 - Perform a physical formatting of the built-in memory/HDD when this unit is to be disposed/transferred. (→ 142)
-
- Do not turn this unit off or remove the SD card, while formatting. Do not expose the unit to vibrations or shock.

Use this unit to format media.

Formatting built-in memory or HDD is only available with this unit.

Do not format an SD card using any other equipment such as a PC. The card may not be used on this unit.

[MEDIA STATUS]

The amount of space left on the SD card, the built-in memory and HDD can be checked. (Only when the mode is at the  position)

- Touching [CHANGE MEDIA] switches the unit between the display for the SD card and the display for the built-in memory/HDD.
 - Touch [EXIT] or press the MENU button to close the indication.
-
- The SD card, built-in memory or built-in HDD requires some space to store information and manage system files, so the actual usable space is slightly less than the indicated value. The usable built-in memory/HDD space is generally calculated as 1 GB=1,000,000,000 bytes. The capacities of this unit, PCs and software are expressed as 1 GB=1,024×1,024×1,024=1,073,741,824 bytes. Therefore, the indicated value of the capacity appears to be smaller.

[CALIBRATION]

Perform the touch screen calibration if a different object to the one touched is selected.

1 Touch [CALIBRATION].

- Touch [ENTER].

2 Touch the [+] that appears on the screen with the supplied stylus pen.



- Touch [+] in sequence (up left → down left → down right → up right → center).

3 Touch [ENTER].

- Calibration cannot be performed when the LCD monitor is turned 180°.

[DEMO MODE]**[OFF]/[ON]**

This item is used to start the unit demonstration.



(Only when the mode is at the  or  position)

If [DEMO MODE] is switched to [ON] when there is no SD card inserted and while this unit is connected to the AC adaptor, the demonstration automatically starts.

If any operation takes place, the demonstration is canceled. However if no operations take place for approx. 10 minutes, the demonstration automatically starts again. To stop the demonstration, set [DEMO MODE] to [OFF] or insert an SD card.

[O.I.S. DEMO]

This item is used to start the Optical Image Stabilizer demo.

(Only when the mode is at the  or  position)

Touch [O.I.S. DEMO], the demonstration automatically starts.

When you touch [EXIT], the demonstration will be canceled.

[LANGUAGE]**[English]/[Français]/[Español]**

You can select the language on the screen display and the menu screen.

3

Using with the remote control

Select the menu.

[MENU] : [SETUP] →
[REMOTE CONTROL] → [ON]

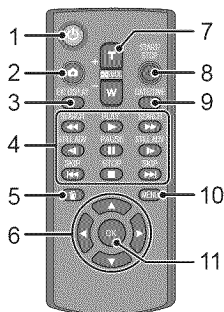

1 Power on/off button []

Power can be turned on/off when the LCD monitor is opened or the viewfinder is extended.

- Power cannot be turned on by the power on/off button when 36 hours have passed after the power is turned off. Press the power button on the unit and turn the power back on.
- Power cannot be turned off when it is connected to the PC or the DVD burner.

2 Photoshot button []^{*}3 On-screen display button
[EXT DISPLAY] (→ 103)

4 Playback operation buttons (→ 41, 86)

These buttons function in the same manner as the corresponding playback operation icon being displayed on screen.

[Excluding skip playback. (→ 86)]

5 Delete button []^{*}

6 Direction buttons []

7 Zoom/volume/thumbnail display
switch buttons [T, W, /VOL]*8 Recording start/stop button [START/STOP]^{*}

9 Date/time button [DATE/TIME] (→ 47)

10 Menu button [MENU]^{*}

11 OK button [OK]

* means that these buttons function in the same manner as the corresponding buttons on the unit.

Remove the insulation sheet **A** before using.

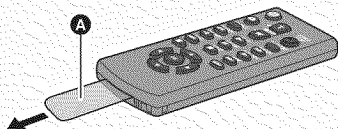

Replacing a button-type battery

- 1 While pressing the stopper **B**, pull out the battery holder.

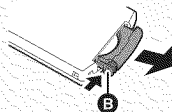

- 2 Set the button-type battery with its (+) mark facing upward and then put the battery holder back in place.



- When the button-type battery runs down, replace it with a new battery (part number: CR2025). The battery should normally last about 1 year, however this depends on how frequently the unit is used.
- Keep the button-type battery out of reach of children to prevent swallowing.

CAUTION

Danger of explosion if battery is incorrectly replaced. Replace only with the same or equivalent type recommended by the manufacturer. Dispose of used batteries according to the manufacturer's instructions.

Replace battery with Panasonic PART NO. CR2025 only. Use of another battery may present a risk of fire or explosion. Caution: Battery may explode if mistreated. Dispose of used battery promptly. Keep away from children. Do not recharge, disassemble or dispose of in fire.

■ Remote control usable range

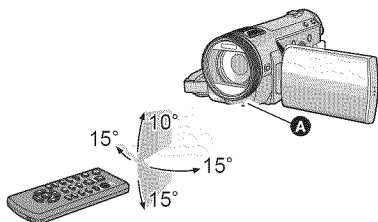

A Remote control sensor

Distance: Within approx. 5 m (16 feet)
Angle: Approx. 10° up and 15° down, left, and right

- The remote control is intended for indoor operation. Outdoors or under strong light, the unit may not operate properly even within the usable ranges.

Operation of direction buttons/OK button

1 Press a direction button.

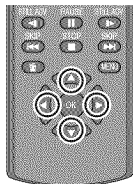

- Selected item will become yellow.

2 Select the item with the direction button.

3 Confirm the selection by pressing the OK button.

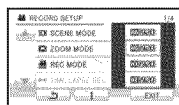

- Selection/confirmation of operation icons, thumbnail display etc. can be operated.
- All touch operations on the unit can also be operated by the remote control (some exceptions).

1

Zoom in/out function

The maximum optical zoom ratio is 12×.

The default setting of the [ZOOM MODE] is [i.Zoom 18×]. It can be extended to a maximum of 18× during Motion Picture Recording Mode. (→ 66)

◇ Change the mode to  or .

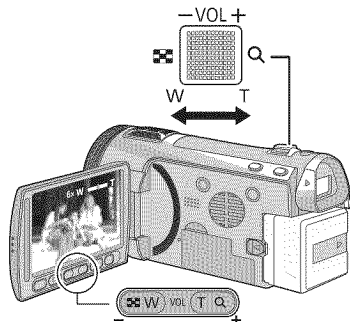

Zoom lever/Adjust zoom buttons

T side:

Close-up recording (zoom in)

W side:

Wide-angle recording (zoom out)

- The zoom speed varies depending on the range over which the zoom lever is moved.
- The adjust zoom buttons are useful for making fine adjustments to the zoom magnification.

Ring zoom

VIDEO PHOTO

Zoom operation can be done using the multi manual ring.

Zoom by rotating the ring.

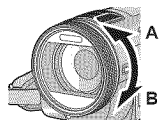

A side:

Close-up recording
(zoom in)

B side:

Wide-angle
recording (zoom out)

- The zoom speed varies depending on the speed to rotate the ring.



Extra Optical Zoom

PHOTO

If the number of the recording pixels is set to anything other than the maximum number of recording pixels in Still Picture Recording Mode, the still picture can be recorded with a zoom ratio of a maximum of 25× without degrading the picture quality.

- Extra optical zoom ratio varies depending on the setting of [PICTURE SIZE] and [ASPECT RATIO]. (→ 78, 79)

■ Extra optical zoom mechanism



When you set the picture size to , the maximum  area is cropped to the center  area, allowing a picture with a higher zoom effect.

- If you take your finger off the zoom lever during zoom operation, the operation sound may be recorded. When returning the zoom lever to the original position, move it quietly.
- When the zoom magnification is 12×, the subjects are focused at about 1.2 m (3.9 feet) or more.
- When the zoom magnification is 1×, this unit can focus on a subject approx. 4 cm (1.6") away from the lens.
- The zoom speed does not vary when operating with the adjust zoom buttons and the remote control.

Optical Image Stabilizer Function

VIDEO PHOTO

Optical Image Stabilizer can stabilize the image without decreasing the image quality as much.

◇ Change the mode to  or .

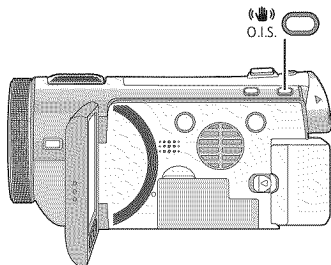

Optical image stabilizer button

Pressing the button changes the Optical image stabilizer setting.

(Motion Picture Recording Mode)

 →  → OFF

(Still Picture Recording Mode)

₁ / ₂ → ₁ / ₂ → OFF

- Switch to Manual Mode before setting the Optical image stabilizer function to off.

: Active mode

This setting gives more stabilization and is suitable for recording when walking.

: ON

This setting is suitable for recording in a stable state such as scenery. We recommend recording with a tripod in Motion Picture Recording Mode.

■ Changing the Optical Image Stabilizer function when in Still Picture Recording Mode





 : [RECORD SETUP] → [O.I.S.] → [MODE1] or [MODE2]

[MODE1]:

The function works all the time.

[MODE2]:



The function works when the  button is pressed. We recommend you are recording yourself or recording with a tripod in Still Picture Recording Mode.

- When in [MODE1], ₁ / ₁ appears. When in [MODE2], ₂ / ₂ appears.

- Stabilization may not be possible under strong shaking conditions.

It is possible to set the focus and exposure to the subject specified on the touch screen. The focus and exposure will keep following the subject automatically even if it moves.

(Dynamic tracking)

◇ Change the mode to  or .

1 Touch .





-  will be displayed on the screen.
- When [FACE RECOG.] (→ 68) is [ON] and a registered face is detected, the target is automatically locked.

2 Touch the object and lock the target.



A Target frame

- When you touch the head of the object, the target frame on the head gets locked and tracking starts.
- Touch the object to be changed again when you want to change the target.
- When the Intelligent Auto Mode is selected, the setting becomes  (Normal) and touched object is tracked. Selection becomes  (Portrait) when target frame is locked on a face. (It may turn to  (Normal) even if the target is locked on the face when a spotlight is shining or with a dark scene.)
- AF/AE tracking will be canceled in the following cases.
 - When the mode is changed
 - When the power is turned off
 - When the Scene mode is set
 - Switch to Intelligent Auto Mode/Manual Mode
 - Switch to face-to-face recording
- After setting [DISPLAY] to [OFF] if no operation is performed for a few seconds, the operation icon disappears. Touch the screen to display the icon again. When the AF/AE tracking is used, the icon does not disappear.

3 Start recording.

- When you touch [RETURN], the tracking function will be canceled.

■ About target frame

- When target lock fails, the target frame blinks in red and then disappears. Touch a characteristic part (color etc.) on the object to lock onto it again.
- When the  button is pressed halfway in Still Picture Recording Mode, the focus is set to the object that is locked. The target frame turns green when it focuses, and the target cannot be changed.

- It may track different objects or may not lock the target depending on the recording conditions such as the following:
 - When the object is too large or too small
 - When color of the object is similar to the background
 - When the scene is dark
- When the target is locked in Still Picture Recording Mode, the screen may become dark or the AF assist lamp may turn on.

This is a 1080/60p (1920×1080/60 progressive) recording mode that can record in maximum quality*.

* This means the highest quality for this unit.

◇ Change the mode to  .

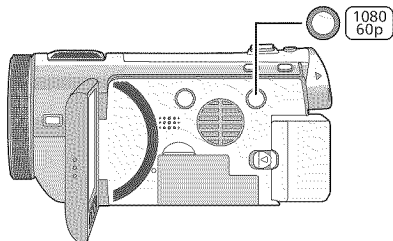

1080/60p button

To set to 1080/60p recording mode, press and hold the button until  is displayed.

- To return to normal recording mode, press and hold the button until  disappears.



- Please refer to page 147 for details about approximate recordable time.

1080/60p

- The scenes recorded in 1080/60p can be saved or played back by this unit or the HD Writer AE 2.1.



Recording functions of operation icons

Select the operation icons to add different effects to the images to be recorded.

◇ Change the mode to  or .

1 Touch  to display the operation icons on the screen.















- Touch  at the bottom right of the screen to change the page and touch  /  to display/not-display the operation icon.

2 (e.g. Backlight compensation)
Select an operation icon.



- Select the operation icon again to cancel the function.
- Refer to the respective pages for canceling the following functions.
 - Smile shot (→ 61)
 - Self-timer (→ 62)
 - Built-in flash (→ 61)

Operation icons

	Fade* ¹
	Intelligent contrast control* ^{1, 2}
PRE-REC	PRE-REC* ¹
	Smile shot* ¹
	Built-in flash* ³
	Red-Eye Reduction* ^{2, 3}
	Self-timer* ³
	Intelligent exposure* ^{2, 3}
	Backlight compensation
	Soft skin mode* ²
	Tele macro
	Guideline
	Color Night Rec* ^{1, 2}
	Headphone volume adjustment* ⁴

*1 Not displayed in Still Picture Recording Mode.

*2 Not displayed in the Intelligent Auto Mode.

*3 Not displayed in Motion Picture Recording Mode.

*4 It is displayed only when a headphone is connected to the headphone output terminal.

- If you turn off the power or change the mode to , PRE-REC, Color night rec, Backlight compensation, Self-timer and Tele macro functions are canceled.
- If you turn off the power, the Fade function is canceled.
- It is possible to set from the menu. (Except for the PRE-REC, on/off of the Guideline, and Headphone volume adjustment)
- After setting [DISPLAY] to [OFF] if no operation is performed for a few seconds, the operation icon disappears. Touch the screen to display the icon again.

Fade

VIDEO

When you start recording, the image/audio gradually appears. (Fade in)

When you pause recording, the image/audio gradually disappears. (Fade out)

- The Fade setting is canceled when the recording stops.

■ To select the color for Fade in/out

 : [RECORD SETUP] → [FADE COLOR] → [WHITE] or [BLACK]

(Fade in)



(Fade out)



- The thumbnails of scenes recorded using fade in become black (or white).

Intelligent contrast control

VIDEO

This brightens parts that are in shadow and difficult to see and suppresses white saturation in bright parts at the same time. Both bright and dark parts can be recorded clearly.

- If there are extremely dark or bright parts or the brightness is insufficient, the effect may not be clear.

PRE-REC

This prevents you from missing a shot.

VIDEO

This allows recording of the pictures and sound to start approximately 3 seconds before the recording start/stop button is pressed.

-  appears on the screen.

- Aim the unit at the subject beforehand.
- There is no beep sound.
- PRE-REC is canceled in the following cases.
 - If you change the mode.
 - If you remove the SD card while [MEDIA SELECT] is set to [VIDEO/SD CARD]
 - If you press the MENU button or 1080/60p button.
 - If you turn the unit off.
 - If you start recording.
 - After 3 hours have passed
- After setting PRE-REC, if recording starts in less than 3 seconds, or while the PRE-REC indication flashes within about 3 seconds after initiating the Quick start operation, motion pictures taken 3 seconds before pressing the recording start/stop button cannot be recorded.
- Images displayed on the thumbnail in Playback Mode will differ from the motion pictures displayed at the start of playback.



Smile shot

PHOTO

When a smiling face is detected during motion picture recording, the unit automatically records a still picture.

The icon changes each time it is touched.

(ON) → (Face Recognition) → OFF

: The unit records a still picture on detecting a smiling face.

: Still pictures are only recorded when the face of a person registered using Face Recognition (→ 68) is detected.

OFF: Cancel the setting.

- During smile shot recording, / are red and the face detected as a smiling face is surrounded by a green frame.
- does not function when [FACE RECOG.] is [OFF] or no one is registered.

- The face of the subject may not be detected correctly depending on the recording conditions.
- The number of recording pixels are (4864×2736), (3840×2160) or (1920×1080). (→ 78)
- When still pictures that have been recorded using the Smile Shot are displayed as thumbnails, the appears.
- When the AF/AE tracking function is target locking a face of the subject, still pictures are only recorded if a smile is detected on the locked subject. When the Smile Shot function is set to (Face Recognition), it will record only if the face of a subject registered with [FACE RECOG.] is locked as a target.



Built-in flash

PHOTO

When the button is pressed, the flash is activated and the picture will be recorded. Use the Built-in flash in order to record still pictures in dark places.

Each time the icon is selected, the indication changes by one setting in the following order:

([ON]) → ([AUTO]) → ([OFF])

- When the button is pressed halfway, the flash indicator will appear.
- The unit automatically determines if the flash is necessary even when it has been set to by detecting the ambient brightness. (If it determines that the flash is necessary, the indication lights up in red when the button is pressed halfway.)

■ To adjust the brightness of the flash



: [PICTURE] → [FLASH LEVEL] → desired setting

[-]: Less bright

[±0]: Normal

[+]: Much brighter

- Set the flash to where using a flash is prohibited.
- The light from the flash may be blocked by the lens hood when the lens hood is attached.
- Do not use the flash with the ND filter (optional) or the conversion lens (optional) attached.

- If the  indication etc. flashes when the  button is pressed halfway, the flash is not activated.
- The available range of the flash is approx. 1 m to 2.5 m (3.3 feet to 8.2 feet) in dark places.
- Using the flash fixes a shutter speed to 1/500 or slower.

Red-Eye Reduction

PHOTO

Reduces the phenomena where human eyes become red from flashes.







- The flash is activated 2 times.
- The red-eye phenomenon tends to appear in certain recording conditions and more with some people than with others.
- When faces are detected in the Intelligent Auto Mode, the Red-Eye Reduction is set to on.

Self-timer

PHOTO



This is for recording still pictures using the timer.

Each time the  icon is selected, the indication changes by one setting in the following order:

-  10 (Records after 10 seconds) →  2 (Records after 2 seconds) → setting canceled
- When the  button is pressed, a still picture is recorded after the  or  display and the recording lamp flashes for the time which has been set. After recording, the Self-timer is canceled.
- In Auto Focus Mode, if the  button is pressed halfway once and then fully, the lens focuses on the subject when the button is pressed halfway. If the  button is pressed fully all at once, the lens focuses on the subject just before recording.

To stop the timer midway through

Press the MENU button.

- Setting the Self-timer to  2 is a good way to prevent image shake when the  button is pressed while using a tripod etc.

Intelligent exposure

PHOTO

This brightens dark areas so the image can be recorded clearly.

- If there are extremely dark parts or the brightness is insufficient, the effect may not be clear.

Backlight compensation

VIDEO

PHOTO

This makes the image brighter to prevent darkening of a backlit subject.



Soft skin mode

VIDEO

PHOTO

This makes skin colors appear softer for a more attractive appearance. This is more effective if you record a person closely from the torso up.

- If the background or anything else in the scene has colors similar to the skin color, they will also be smoothed.
- If the brightness is insufficient, the effect may not be clear.
- If you record a person in the distance, the face may not be recorded clearly. In this case, cancel Soft Skin Mode or zoom in on the face (close-up) to record.



Tele macro

VIDEO

PHOTO

A more impressive image can be obtained by focusing on the object only in close-up and shading off the background.

- The unit can focus on the subject at a distance of approx. 70 cm (28").
 - If the magnification is 12× or less, then it is automatically set to 12×.
- Tele Macro function is canceled when the zoom magnification becomes lower than 12×.



Guideline

VIDEO

PHOTO

You can check if the image is level while recording or playing back motion pictures and still pictures. The function can also be used to estimate the balance of the composition.



- The guidelines do not appear on the images actually recorded.

■ Selecting the type of Guideline

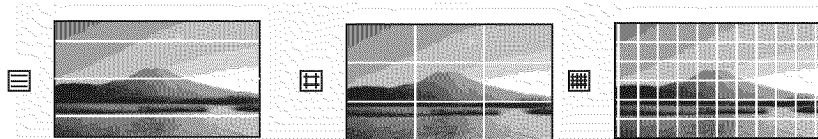
-  : [RECORD SETUP] → [GUIDE LINES] → desired setting
- It is possible to set from the quick menu. (→ 45)



■ Displaying Guidelines at playback

- Change the mode to  .
-  : [VIDEO SETUP] → [GUIDE LINES] → desired setting
- To cancel the Guideline function during playback, set to [OFF].

This function allows you to record color images in very low light situations. (Minimum required illumination: approx. 1 lx)

- Recorded scene is seen as if frames were missed.
- If set in a bright place, the screen may become washed out for a while.
- Bright dots that are usually invisible may be seen, but this is not a malfunction.
- Using a tripod is recommended.
- In darker areas, Auto Focus may focus a bit slower. This is normal.

🎧 **Headphone volume adjustment**

Adjusts the volume of the headphone while recording. (When the LCD monitor is in use)

▲: Increases the volume

▼: Decreases the volume

- Actual volume to be recorded does not change.

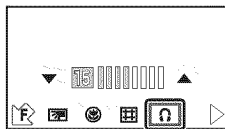



Recording functions of
menus

[SCENE MODE]

VIDEO











PHOTO

When you record images in different situations, this mode automatically sets optimum shutter speeds and apertures.

- Change the mode to  or .

 : [RECORD SETUP] → [SCENE MODE] → desired setting

[OFF]:

	Cancel the setting
 Sports:	To make fast moving scenes less shaky with slow playback and pause of playback
 Portrait:	To make people stand out against the background
 Spotlight:	Improved quality when subject is brightly illuminated.
 Snow:	Improved image quality when shooting in snowy locations.
 Beach:	To make blue in the sea or sky vibrant
 Sunset:	To make red in the sunrise or sunset vibrant
 Fireworks:	To capture the fireworks in the night sky beautifully
 Scenery:	For spatial scenery
 Low light:	For dark scenes, such as at dusk (In Motion Picture Recording Mode only)
 Night scenery:	To capture the evening or night scenery beautifully.
 Night portrait:	To capture a person and the background brightly. (In Still Picture Recording Mode only)

- (Sports/Portrait/Spotlight/Snow/Beach/Sunset/Scenery)

- The shutter speed is 1/8 or more in Still Picture Recording Mode.

- (Sunset/Low light)

- The shutter speed is 1/30 or more (When [DIGITAL CINEMA] is [ON], it is 1/24 or more.) in Motion Picture Recording Mode.

- (Sunset/Fireworks/Scenery/Night scenery)

- Image may get blurry when a close object is recorded.

- (Sports)

- During normal playback, the image movement may not look smooth.
- Color and screen brightness may change under indoor lighting.
- If the brightness is insufficient, the Sports Mode does not function. The  display flashes.

- (Portrait)

- Color and screen brightness may change under indoor lighting.

- **(Fireworks)**
 - The shutter speed is 1/30.
 - Image may get washed out when recorded in bright surroundings.
- **(Night scenery/Night portrait)**
 - The shutter speed is 1/2 or more in Still Picture Recording Mode.
 - Using a tripod is recommended.
- **(Night portrait)**
 - The flash is set to [ON].

[ZOOM MODE]

VIDEO

PHOTO

Set the maximum zoom ratio for the Motion Picture Recording Mode.

- Change the mode to .

 : [RECORD SETUP] → [ZOOM MODE] → desired setting

[Opt.Zoom 12×]:	Optical zoom only (Up to 12×)
[i.Zoom 18×]:	This zoom function allows you to maintain high-definition picture quality (Up to 18×)
[D.Zoom 30×]:	Digital zoom (Up to 30×)
[D.Zoom 700×]:	Digital zoom (Up to 700×)

- The larger the digital zoom magnification, the more the image quality is degraded.

[REC MODE]

VIDEO

Switch the picture quality of the motion pictures to be recorded.

- Change the mode to .

 : [RECORD SETUP] → [REC MODE] → desired setting

- It is possible to set from the quick menu. (→ 45)

[HA]/[HG]/[HX]/[HE]



- A Favors image quality
- B Favors recording time

- **Recordable time using the battery (→ 24)**
- This function's default setting is HG mode.
- Please refer to page 147 about approximate recordable time.
- When the unit is moved a lot or moved quickly, or when a fast-moving subject is recorded (particularly when recording in HE mode), mosaic-type noise may appear at playback.

[TIME LAPSE REC]

VIDEO

A scene that moves slowly for long period of time is recorded frame by frame with an interval, and is recorded as a short time motion picture.

A frame is recorded with a set recording interval.

30 frames will make up motion picture of 1 second.

- Change the mode to .

 : [RECORD SETUP] → [TIME LAPSE REC] → desired setting

- It is possible to set from the quick menu. (→ 45)

[OFF]:

Cancel the setting

[1 SECOND]/[10 SECONDS]/[30 SECONDS]/[1 MINUTE]/[2 MINUTES]:

Change the recording interval.

-  appears on the screen.
- After recording, the setting of interval recording is canceled.
- Audio cannot be recorded.

Setup example	Setup time (recording interval)	Recording time	Recorded time
Sunset	1 s	Approx. 1 h	Approx. 2 min
Blooming	30 s	Approx. 3 h	Approx. 12 s

- Maximum recordable time is 12 hours.
- Still picture recording cannot be used.
- Recording mode cannot be changed when the Interval recording is set.
- If you turn off the power or change the mode to , this function is canceled.
- The shortest motion picture recording time is 1 second.
- Color balance and focus may not be adjusted automatically depending on light sources or scenes. If so, manually adjust these settings. (→ 83, 85)

[DIGITAL CINEMA]

VIDEO

Use this function to record an image with vivid color, like an image on a movie film.

- Change the mode to .
- Switch to Manual Mode. (→ 82)
- Set the Recording mode to HA or HG. (→ 66)



 : [RECORD SETUP] → [DIGITAL CINEMA] → [ON]

- The shutter speed is 1/48 or more. (When [AUTO SLOW SHTR] is [ON], it is 1/24 or more.)
- This function cannot be used in the Intelligent Auto Mode or 1080/60p recording mode.
- The images may not appear smooth.

It is possible to continuously record motion picture to an SD card when there is no space available in the built-in memory. (It allows you to record only to SD card from built-in memory.)



- Change the mode to  .

 : [RECORD SETUP] → [RELAY REC] → [ON]

- ⇄  is displayed on the screen. ⇄  will disappear when space in the built-in memory is gone and the recording to the SD card starts.
 - Relay recording can only be performed once.
 - **Combine the scenes that were relay-recorded using the [RELAY SCENE COMBINE] into the SD card. (→ 99, 107)**
 - Once you have performed [RELAY SCENE COMBINE], you can use the Relay Recording function again. If the [RELAY REC] is set to [ON] without performing the [RELAY SCENE COMBINE], a message is displayed. You will be able to perform Relay Recording by touching [YES], but you will not be able to perform the [RELAY SCENE COMBINE] after that.
-
- Still pictures are recorded to the SD card after Relay recording.
 -  is displayed on the thumbnail display during the playback of a scene that was relay-recorded on the built-in memory.

[FACE RECOG.]

Face Recognition is a function for finding faces that resemble faces which have already been registered and automatically prioritizing focus and exposure for those faces. This function makes it possible to keep the face of your loved ones in focus even when they are at the back or on the end of a line in a group picture.

- Change the mode to  or  .

 : [RECORD SETUP] → [FACE RECOG.] → desired setting

- [OFF]:** Cancel the setting
- [ON]:** The Face Recognition function is available
- [SET]:** Face Recognition registration/editing/cancellation

■ Registering a face for face recognition

[RECORD SETUP] → [FACE RECOG.] → [SET] → [SAVE]

- Up to a maximum of 6 people can be registered.

1 Align the person's face with the guide.

- Take a picture of the person's face from the front, ensuring that their hair does not hide the outline of their face, their eyes or their eyebrows.

2 Touch [REC] or press the button fully.

- Touch [ENTER].
- It may not be possible to register a face depending on the recording conditions. In this case, try recording the face again.

3 Entering the person's name.

- Touch the text entry icon in the center of the screen and enter the name.
- After entering the name, touch [Enter].



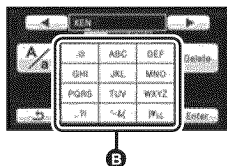

A Guide



B Text entry icon

Entering text

Icon	Description of operation
[A] etc.	Enters a character.
	Moves cursor left.
	Moves cursor right.
[A/a]	Switches between [A]/[a] (alphabet) and [&/1] (symbols/numbers).
[Delete]	Deletes a character. Deletes the previous character if the cursor is in an empty space.
[Enter]	Ends text entry.

- A maximum of 9 characters can be entered.

4 Touch [ENTER] to end registration.

- Touch [EXIT].

■ Changing the information of a registered person

1 Select the menu.

[RECORD SETUP] → [FACE RECOG.] → [SET] → [EDIT]

2 Touch the desired item to enter the setting.

- Up to 3 face shots can be registered. To additionally register or to change/delete the registered face shots, touch  or the face shot.

[SET NAME]:

Change the name.

[PRIORITY]:

Focus and exposure will be set in priority according to the registration order setting from the first person. Target will be locked according to the registration order setting from the first person when AF/AE tracking is active.

- Touch the face shot of the person you wish to promote in the registration order. This will promote the person forward in the order.

[FOCUS ICON]:

This changes the focus indication icon that appears during still picture recording. (Only displayed when Face Recognition is in use.)

- Touch the icon you wish to have displayed.

3 Touch [ENTER].

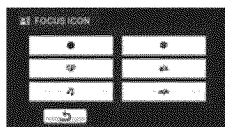

■ Canceling a registered person

1 Select the menu.

[RECORD SETUP] → [FACE RECOG.] → [SET] → [DELETE] or [DELETE ALL]

- Touching [DELETE ALL] cancels all the registered people.

2 (Only when [DELETE] is selected)

Touch the person to cancel.



- When touched, the person is selected and surrounded by orange. Touch the person again to cancel the operation.
- Touch [ENTER].

- Since face recognition searches for faces that resemble the registered faces, there is no guarantee of positive recognition.
- It may not be possible to correctly recognize a person who has been registered due to differences in facial expression and environment.
- Perform the registration again if recognition becomes unstable in cases such as when facial features change with age.

[NAME DISPLAY]

VIDEO**PHOTO**

When a registered person is detected by face recognition during recording, the name registered for that person is displayed.

- Change the mode to  or .

 : [RECORD SETUP] → [NAME DISPLAY] → desired number



[OFF]/[1]/[2]/[3]

- Displayed name will disappear after a while.
- It is displayed according to the registration order setting from the first person.
- This function is not displayed during the face-to-face recording or Playback Mode.

[FACE FRAMING]

VIDEO**PHOTO**

Detected faces appear with frames.

- Change the mode to  or .

 : [RECORD SETUP] → [FACE FRAMING] → desired setting

[OFF]:

Cancel the setting.

[PRIMARY]:

Only the prioritized face framing is displayed.

[ALL]:

All face detection framings are displayed.



- Up to 15 frames are indicated. Larger faces and faces nearer to the center of the screen take preference over others. When [FACE RECOG.] is [ON] registered people are given priority.

■ Prioritized face framing

Prioritized face framing is displayed in orange. Focus and adjustment of brightness will be performed against the prioritized face framing.

- Prioritized face framing is only displayed in Intelligent Auto Mode.
- Focus will be set to prioritized face framing when the  button is pressed halfway when recording still pictures. Prioritized face framing will turn to green when the focus is set.

[AGS]

VIDEO

If the unit continues to be tilted upside down from the normal horizontal position while recording motion pictures, it is automatically put into recording pause.

- Change the mode to .

 : [RECORD SETUP] → [AGS] → [ON]

- The AGS function may activate and cause the unit to pause the recording if you are recording a subject right above or right below you.

[AUTO SLOW SHTR]

VIDEO

PHOTO

You can record bright pictures even in dark places by slowing the shutter speed.

- Change the mode to .
- Switch to Manual Mode. (→ 82)

 : [RECORD SETUP] → [AUTO SLOW SHTR] → [ON]

- The shutter speed is set to 1/30 or more depending on the surrounding brightness.
- This function cannot be used in Still Picture Recording Mode.
- When the shutter speed becomes 1/30, the screen may be seen as if frames are missed and afterimages may appear.

[Digital Cinema Color]

VIDEO

Recording motion pictures with more vivid colors, using x.v.Color™ technology.

- Change the mode to .
- Switch to Manual Mode. (→ 82)

 : [RECORD SETUP] → [Digital Cinema Color] → [ON]

- For more realistic colors, use an HDMI mini cable with a TV that supports the x.v.Color™.
- This function cannot be used when switch to Intelligent Auto Mode.
- When motion pictures recorded while this function is turned [ON] are played back with a TV not compatible with x.v.Color™, colors may not be reproduced properly.
- To play back images recorded in Digital cinema color with vivid colors of wider color ranges, a device compatible with x.v.Color™ is required. When these images are played back with devices other than ones compatible with x.v.Color™, it is recommended to record the images after this function is turned [OFF].
- x.v.Color™ is a name for devices that are compatible with the xvYCC format, an international standard for expanded color in motion pictures, and that follow the rules for signal transmission.

[SHOOTING GUIDE]

VIDEO

Message is displayed when this unit is moved rapidly.

- Change the mode to .

 : [RECORD SETUP] →
[SHOOTING GUIDE] → [ON]

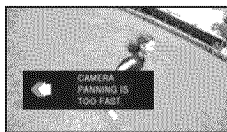

When "CAMERA PANNING IS TOO FAST." appears, move the unit slowly while recording.

- Set to [OFF] to turn off the message indication.
- Message will not appear while pausing the recording. (Message will appear even if it is pausing the recording if [DEMO MODE] is set to [ON].)
- In some recording conditions, messages may not appear.

[WIND NOISE CANCELER]

VIDEO

This will reduce the wind noise coming into the built-in microphones while maintaining the realism.

- Change the mode to .
- Switch to Manual Mode. (→ 82)



: [RECORD SETUP] → [WIND NOISE CANCELER] → [ON]

- When switching to Intelligent Auto Mode, [WIND NOISE CANCELER] is set to [ON], and the setting cannot be changed.
- You may not see the full effect depending on the recording conditions.
- If wind sound cannot be reduced with the Wind noise canceler function alone, set [BASS SETTING] to [LOWCUT]. (→ 75)

[MIC SETUP]

VIDEO

Recording setting of the built-in microphone can be adjusted.

- Change the mode to .
- Switch to Manual Mode. (→ 82)



: [RECORD SETUP] → [MIC SETUP] → desired setting

[SURROUND]:	Sound is recorded with 5.1 ch surround microphone.
[ZOOM MIC]:	Directivity of the microphone is synchronized with the zoom operation. Sounds near the front of the unit are recorded more clearly if you zoom in (close-up) and surrounding sounds are recorded more realistically if you zoom out (wide angle).
[FOCUS MIC]:	Directivity of the center is enhanced for recording audio near the front of the unit more clearly.
[STEREO MIC]:	Sound from two directions is recorded in 2 ch by forward-facing stereo microphones.

- If you wish to record higher quality sound and maintain realism even when zooming in, for instance, when recording a music recital, we recommend setting [MIC SETUP] to [SURROUND].

When recording, the input level from the built-in microphones and the external microphone terminal can be adjusted.

- Change the mode to .
- Switch to Manual Mode. (→ 82)



1 Select the menu.

 : [RECORD SETUP] → [MIC LEVEL] → desired setting

[AUTO]: AGC is activated, and the recording level is adjusted automatically.

[SET+AGC]/[SET]: The desired recording level can be set.

- It is possible to select the setting from the quick menu in Manual Mode. (→ 45) The microphone level returns to the setting adjusted previously, and it cannot be set from the quick menu.

2 Touch  /  to adjust the microphone input level.

- Touch **AGC** to activate/disactivate AGC. When AGC is activated, the icon is surrounded by yellow and the amount of sound distortion can be reduced. When AGC is deactivated, natural recording can be performed.
- Adjust the microphone input level so that the last 2 bars of the gain value are not red. (Otherwise, the sound is distorted.) Select a lower setting for microphone input level.

3 Touch [ENTER] to determine the microphone input level and then touch [EXIT].

-  (Microphone input level meter) appears on the screen.

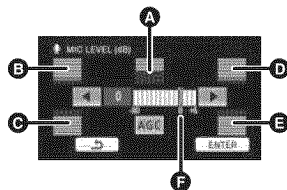

- A** Center
- B** Front left
- C** Back left
- D** Front right
- E** Back right
- F** Microphone input level

- When switching to Intelligent Auto Mode, the setting is fixed to [AUTO] and cannot be changed.
- When [MIC SETUP] is [ZOOM MIC], the volume will be different depending on the zoom rate.
- When [MIC SETUP] is set to [STEREO MIC] or external microphone input is used, the sound is stereo (2 ch) and only the front-left and front-right input level meters function.
- The microphone input level meter shows the largest volume for the microphones.
- You cannot record with the audio completely muted.

[BASS SETTING]

VIDEO

Change the lower setting of the built-in microphone according to your choice.

- Change the mode to .
- Switch to Manual Mode. (→ 82)

 : [RECORD SETUP] → [BASS SETTING] → desired setting

[0dB]/[+3dB]/[+6dB]/[LOWCUT]

- Normally set to [0dB].
- Select [+3dB] or [+6dB] to get strong power feeling at bass level.



[PICTURE ADJUST]

VIDEO

PHOTO

Adjust the quality of the image while recording.

Adjust by outputting to a TV while adjusting the quality of the image.

- Change the mode to  or .
- Switch to Manual Mode. (→ 82)

1 Select the menu.

 : [RECORD SETUP] → [PICTURE ADJUST]



2 Touch the desired setting items.

[SHARPNESS]: Sharpness of the edge

[COLOR]: Depth of the color of the image

[EXPOSURE]: Brightness of the image

[WB ADJUST]: Picture color balance

3 Touch  /  to adjust settings.

4 Touch [ENTER].



- Touch [EXIT] or press the MENU button to complete the settings.
-  appears on the screen.

[ZEBRA]

VIDEO

PHOTO

Parts where white saturation (color saturation) is likely to occur (extremely brightly lit or shiny parts) are displayed with diagonal lines (zebra pattern).

- Change the mode to  or .
- Switch to Manual Mode. (→ 82)

 : [RECORD SETUP] → [ZEBRA] → [ON]

- It is possible to set from the quick menu in Manual Mode. (→ 45)
- You can record an image with little white saturation if you manually adjust the shutter speed or brightness (iris/gain) (→ 84).
- The zebra pattern does not appear on the images actually recorded.



A Zebra pattern



[LUMINANCE]

VIDEO

PHOTO

Displays the luminance level of the center of the screen (luminance display frame) in %. It makes the adjustment of the brightness of the object easier, by checking the luminance level of the object, when recording same object in different surroundings.

Adjust the brightness using [IRIS]. (→ 84)

- Change the mode to  or .
- Switch to Manual Mode. (→ 82)

 : [RECORD SETUP] → [LUMINANCE] → desired setting

- It is possible to set from the quick menu in Manual Mode. (→ 45)

[OFF]:

Cancel the setting.

[ALWAYS]:

Constantly display.

[ON ADJUST]:

Display only when [IRIS] is adjusted. (→ 84)

A Luminance display frame

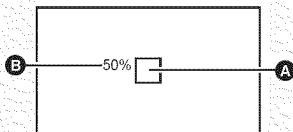

B Luminance level



- Luminance level is displayed between [0%] and [99%]. It will be displayed as [99% ↑] when it is over 99%.
- Luminance is displayed while adjusting [IRIS] even if [DISPLAY] is set to [OFF].

A graph with brightness as horizontal axis and number of pixels at that brightness as vertical axis is displayed. It is possible to determine the exposure of the whole image by looking at the distribution in the graph.

Adjust the brightness using [IRIS]. (→ 84)

- Change the mode to  or .
- Switch to Manual Mode. (→ 82)



: [RECORD SETUP] → [HISTOGRAM] → desired setting

- It is possible to set from the quick menu in Manual Mode. (→ 45)

[OFF]:

Cancel the setting.

[ALWAYS]:

Constantly display.

[ON ADJUST]:

Display only when [IRIS] is adjusted. (→ 84)

- A** Normal
- B** Dark
- C** Bright

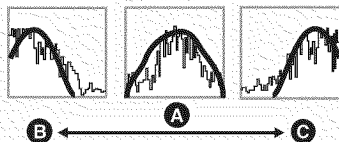
■ Example of the display

- Histogram is displayed while adjusting [IRIS] even if [DISPLAY] is set to [OFF].

The higher the number of pixels, the higher the clarity of the picture when printing.











- Change the mode to .

[MENU] : **[PICTURE]** → **[PICTURE SIZE]** → desired setting

- It is possible to set from the quick menu. (→ 45)

- The number of recording pixels that can be set changes depending on selected screen aspect ratio. (→ 79)

Picture size and Maximum zoom ratio

Aspect ratio	Picture size		Extra optical zoom (→ 55)
4:3		4032×3024	—*
		3200×2400	13.2×
		2560×1920	16.5×
		640×480	25×
3:2		4608×3072	—*
		3600×2400	13.2×
		2880×1920	16.5×
16:9		4864×2736	—*
		3840×2160	13.2×
		3072×1728	16.5×



* Extra optical zoom cannot be used. The maximum zoom magnification is 12×



Picture size in Motion Picture Recording Mode

- Change the mode to .

[MENU] : **[PICTURE]** → **[PICTURE SIZE]** → desired setting

- It is possible to set from the quick menu. (→ 45)

Aspect ratio	Picture size	
16:9		4864×2736
		3840×2160
		1920×1080

- This function's default settings are  in Still Picture Recording Mode and  in Motion Picture Recording Mode.
- Please refer to page 148 for details about the number of recordable pictures.
- The recording will become longer depending on the recording pixels.

Selecting the picture quality.

- Change the mode to  or .

 : [PICTURE] → [QUALITY] → desired setting



Still pictures with a high picture quality are recorded.



Priority is given to the number of still pictures recorded. Still pictures are recorded in normal picture quality.

[ASPECT RATIO]

This allows you to select the aspect ratio of the pictures to suit printing or the playback method.

- Change the mode to .

 : [PICTURE] → [ASPECT RATIO] → desired setting

4:3: Aspect ratio of 4:3 television

3:2: Aspect ratio of conventional film camera or prints (such as L-size print)

16:9: Aspect ratio of high-definition television, etc.

- This function's default setting is [3:2].
- When the aspect ratio is set to [4:3] or [3:2], black bands may appear on the left and right of the screen.
- The edges of still pictures recorded on this unit with a 16:9 aspect ratio may be cut at printing. Check the printer or photo studio before printing.

Recording is done continuously at the rate of 60 still pictures per second. Use this function to record an object with fast movement.

- Change the mode to .

1 Select the menu.

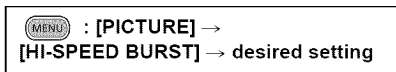



[OFF]:

Cancel the setting.

[60 frames/sec]:

180 still pictures are recorded continuously at the rate of 60 per second. The picture size is 2.1M (1920×1080).

2 Press the button.

-  flashes in red during recording.
- First press the  button halfway, then press it fully to set the focus and record. It will automatically focus if you press fully once, so it is convenient when recording objects moving back and forth.

3 Touch [Record] or [Delete].

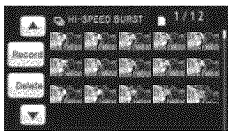

[Record]: Pictures are stored.
[Delete]: All pictures are deleted.

4 (Only when [Record] is selected in step 3)

Touch **[REC ALL]** or **[SELECT]**.

[REC ALL]: All pictures are stored.



[SELECT]: Pictures are stored by specifying range.

5 (Only when [SELECT] is selected in step 4)

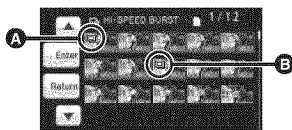
Touch the range of pictures that will be stored.



- A Start point*
- B Finish point

- Previous (Next) page is displayed by touching  / .
- * Only select the picture for start point if only 1 picture is to be stored.
- A confirmation message is displayed when [Enter] is touched after selecting the start point and finish point. Touch [YES] to store the pictures.

- If you turn off the power or change the mode, this function is canceled.
- The maximum number of times you can record on a media is 15.
(In the case of SD cards it is the maximum number of recordable scenes per card.)
- Color balance and brightness on the screen may change with some light sources such as fluorescent lamps.
- Image quality is different from ordinary still picture recording.

[AF ASSIST LAMP]

PHOTO

Illuminating the subject makes it easier for the camera to focus when recording in low light conditions that make focusing difficult.

- Change the mode to .
- Switch to Manual Mode. (→ 82)

 : [PICTURE] → [AF ASSIST LAMP] → [AUTO]

- The available distance of the AF assist lamp is approx. 1.5 m (5 feet).
- A conversion lens (optional) can block the AF assist lamp, and it will become harder to adjust the focus.
- When switching to Intelligent Auto Mode, the setting is fixed to [AUTO] and cannot be changed.

[SHTR SOUND]

PHOTO

You can add a shutter sound when recording still pictures.



- Change the mode to .

 : [PICTURE] → [SHTR SOUND] → [OFF] /  / 

- No shutter sound is emitted in Motion Picture Recording Mode.

Recording manually by setting white balance, shutter speed or iris adjustment

The operation sequence differs for the LCD monitor and viewfinder.

◇ Change the mode to  or .

Press the **iA/MANUAL** button or **CAMERA FUNCTION** button to switch to **Manual Mode**.

- **MNL** appears on the screen.

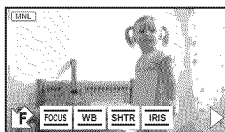
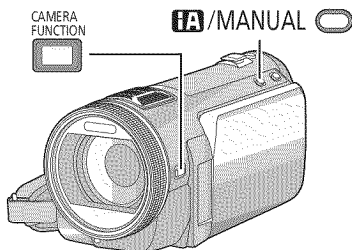



- FOCUS Focus (→ 85)
- WB White balance (→ 83)
- SHTR Manual shutter speed (→ 84)
- IRIS Aperture adjustment (→ 84)

■ When using the LCD monitor

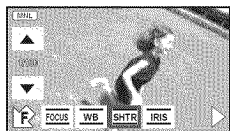
- 1 Touch the desired item to be set.
- 2 Touch  /  to enter the selection.



- Press the **iA/MANUAL** button to cancel manual setting.
- Touch  to change the page and the manual icon appears or disappears each time  /  is touched.

■ When using the viewfinder

- 1 Press the **CAMERA FUNCTION** button to select the desired item.
 - Selected item changes whenever the **CAMERA FUNCTION** button is pressed.
- 2 Rotate the multi manual ring to select the setting and press the **CAMERA FUNCTION** button to enter the setting.

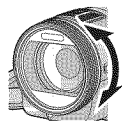
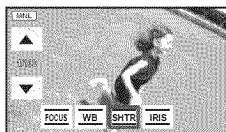

- Zoom operation cannot be done using the multi manual ring during setting.







Automatic white balance function may not reproduce natural colors depending on the scenes or lighting conditions. If so, you can adjust the white balance manually.

- Press the **iA/MANUAL** button or **CAMERA FUNCTION** button to switch to Manual Mode. (→ 82)
- For how to perform the settings when using the viewfinder, refer to page 82

1 Touch [WB].



2 Touch / to select White balance mode.

- Select the optimal mode by confirming the color on the screen.



Icon	Mode/Recording conditions
	Auto white balance adjustment
	Sunny mode Outdoors under a clear sky
	Cloudy mode Outdoors under cloudy sky
	Indoor mode 1 Incandescent light, video lights like in the studio, etc.
	Indoor mode 2 Color fluorescent lamps, sodium lamps in gymnasiums etc.
	Manual adjustment mode <ul style="list-style-type: none"> ● Mercury-vapor lamps, sodium lamps, some fluorescent lights ● Lights used for wedding receptions at hotels, stage spotlights in theaters ● Sunrise, sunset, etc.

- To return to auto setting, set to **AWB** or press the **iA/MANUAL** button again.

■ To set the white balance manually

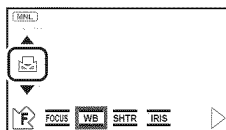
- 1 Select , fill the screen with a white subject.
- 2 Touch and set the blinking .



- When using the viewfinder, press and hold the **CAMERA FUNCTION** button.
 - When the screen turns black instantly and the  display stops flashing and then lights constantly, the setting is complete.
 - If the  display continues flashing, the white balance cannot be set. In this case, use other White balance modes.
-
- When the  display flashes, the manual white balance previously adjusted is stored. Whenever recording conditions change, re-set the white balance.
 - When setting both the white balance and the iris/gain, set the white balance first.
 - **AWB** is not displayed on the screen when **AWB** is being set.

Shutter Speed:

Adjust it when recording fast-moving subjects.

Iris:

Adjust it when the screen is too bright or too dark.

● Press the **iA/MANUAL** button or **CAMERA FUNCTION** button to switch to **Manual Mode**. (→ 82)

● For how to perform the settings when using the viewfinder, refer to page 82

1 Touch [SHTR] or [IRIS].

2 Touch / to adjust settings.

Shutter speed:

1/60 to 1/8000

- If [AUTO SLOW SHTR] is set to [ON], the shutter speed will be set between 1/30 and 1/8000.
- If [DIGITAL CINEMA] is set to [ON], the shutter speed will be set between 1/48 and 1/8000. (When [AUTO SLOW SHTR] is set to [ON], the range is 1/24 to 1/8000.)
- The shutter speed closer to 1/8000 is faster.
- The shutter speed will be set between 1/2 and 1/2000 in Still Picture Recording Mode.

Iris/Gain value:

CLOSE ↔ (F16 to F1.7) ↔ OPEN ↔ (0dB to 18dB)

- Value closer to [CLOSE] darkens the image.
- Value closer to [18dB] brightens the image.
- When the iris value is adjusted to brighter than [OPEN], it changes to the gain value.
- To return to auto setting, press the **iA/MANUAL** button again.

-
- When setting both the shutter speed and the iris/gain value, set the shutter speed and then set the iris/gain value.

Manual shutter speed adjustment

- When the shutter speed is set lower than 1/15 in the Still Picture Recording Mode, using a tripod is recommended. Also, white balance cannot be set. The shutter speed will be set to 1/30 when the power is turned on again or when the Quick start is performed.
- You may see a band of light around an object that is shining very bright, or highly reflective.
- During normal playback, image movement may not look smooth.
- If you record an extremely bright object or record under indoor lighting, color and screen brightness may change or a horizontal line may appear on the screen. In this case, record in the Intelligent Auto Mode or set the shutter speed to 1/60 in areas where the power supply frequency is 60 Hz, or 1/100 in areas of 50 Hz.

Manual iris/gain adjustment

- Luminance level and histogram are displayed during the iris adjustment. (→ 76, 77)
- If the gain value is increased, the noise on the screen increases.
- Depending on the zoom magnification, there are iris values that are not displayed.

Panasonic Consumer Electronics Company,
Division of Panasonic Corporation of North America
One Panasonic Way, Secaucus, NJ 07094

Panasonic Canada Inc.
5770 Ambler Drive, Mississauga, Ontario, L4W 2T3



VQT2M75
F0210KK0 (6500 (A))

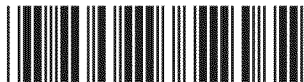

© Panasonic Corporation 2010
Printed in Japan