

SANYO

GUIDE FOR BASIC OPERATION

Dual Camera

Xacti 

VPC-CS1EX

VPC-CS1

VPC-CS1GX

VPC-CS1PX

VPC-CS1TA

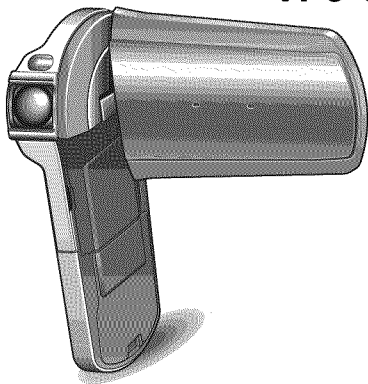



HIGH-DEFINITION MULTIMEDIA INTERFACE

Important note

This manual explains how to safely operate the VPC-CS1EX, VPC-CS1, VPC-CS1GX, VPC-CS1PX and VPC-CS1TA.

Any information regarding only one of these products will be labeled as such.

Please read these instructions carefully before using the camera.
Make sure to read and understand the separate booklet "SAFETY MANUAL".
Keep this manual in a safe place for later reference.

Warning

TO PREVENT THE RISK OF FIRE OR ELECTRIC SHOCK, DO NOT EXPOSE THIS APPLIANCE TO RAIN OR MOISTURE

■ FOR AMERICAN USERS

The following advisory is included in accordance with the laws of the State of California (USA):

WARNING:

This product contains chemicals, including lead, known to the State of California to cause cancer, birth defects or other reproductive harm. **Wash hands after handling.**

- This equipment has been tested and found to comply with the limits for a Class B digital device, pursuant to Part 15 of the FCC Rules. These limits are designed to provide reasonable protection against harmful interference in a residential installation. This equipment generates, uses and can radiate radio frequency energy and, if not installed and used in accordance with the instructions, may cause harmful interference to radio communications. However, there is no guarantee that interference will not occur in a particular installation. If this equipment does cause harmful interference to radio or television reception, which can be determined by turning the equipment off and on, the user is encouraged to try to correct the interference by one or more of the following measures:
 - Reorient or relocate the receiving antenna.
 - Increase the separation between the equipment and receiver.
 - Connect the equipment into an outlet on a circuit different from that to which the receiver is connected.
 - Consult the dealer or an experienced radio/TV technician for help.
- Changes or modifications not expressly approved by the party responsible for compliance could void the user's authority to operate the equipment.

Declaration of Conformity

Model number: VPC-CS1

Trade Name: SANYO

Responsible party: SANYO North America Corporation

Address: 21605 Plummer Street, Chatsworth, California 91311

Telephone No.: (818) 998-7322

This device complies with Part 15 of the FCC Rules. Operation is subject to the following two conditions:

- (1) this device may not cause harmful interference, and
- (2) this device must accept any interference received, including interference that may cause undesired operation.

FOR USERS IN THE USA

About the battery charger

IMPORTANT SAFETY INSTRUCTIONS – SAVE THESE INSTRUCTIONS DANGER – TO REDUCE THE RISK OF FIRE OR ELECTRIC SHOCK, CAREFULLY FOLLOW THESE INSTRUCTIONS

- For connection to a supply not in the U.S.A., use an attachment plug adapter of the proper configuration for the power outlet.
- **Power Supply Cord:**
Use UL Listed detachable power supply cord - No. 18 AWG, two conductors, rated 10 A, VW-1, 105 °C, 125/250 V, minimum 1.8 m, maximum 3 m long. Provided with a molded-on, non-polarized attachment plug with a 15 A, 250 V (NEMA 2-15P) configuration or a 15 A, 125 V (NEMA 1-15P) configuration and a molded-on connector which mates with the Power Inlet.

Cord Type

Basic Cord Type	Other Suitable Types
TS	TST
SP-2	SPE-2, SPT-2
SP-3	SPE-3, SPT-3
SV	SVE, SVO, SVOO, SVT, SVTO, SVTOO
SJ	SJE, SJO, SJOO, SJT, SJTO, SJTOO
S	SE, SO, SOO, ST, STO, STOO

- This device complies with Part 15 of the FCC Rules. Operation is subject to the following two conditions: (1) this device may not cause harmful interference, and (2) this device must accept any interference received, including interference that may cause undesired operation.

PARA LOS USUARIOS DE EE.UU.

Acerca del cargador de baterías

INSTRUCCIONES IMPORTANTES SOBRE DE SEGURIDAD - GUARDE ESTAS INSTRUCCIONES PELIGRO - PARA REDUCIR EL RIESGO DE INCENDIO O DESCARGAS ELÉCTRICAS, SIGA CUIDADOSAMENTE ESTAS INSTRUCCIONES

- Para la conexión a una red de alimentación que no sea de EE.UU., utilice el adaptador de enchufe apropiado para la toma de la red.
- **Cable de alimentación:**
Utilice el cable de alimentación UL desenchufable indicado en la lista - N.º 18 AWG, dos conductores, amperaje nominal de 10 A, VW-1, 105 °C, 125/250 V, mínimo 1,8 m, máximo 3 m de longitud. Provisto de enchufe moldeado, adaptador de enchufe no polarizado con configuración de 15 A, 250 V (NEMA 2-15P), o configuración de 15 A, 125 V (NEMA 1-15P) y conector moldeado que se adapta a la toma de corriente de la red.

Tipo de cable

Tipo de cable básico	Otros tipos adecuados
TS	TST
SP-2	SPE-2, SPT-2
SP-3	SPE-3, SPT-3
SV	SVE, SVO, SVOO, SVT, SVTO, SVTOO
SJ	SJE, SJO, SJOO, SJT, SJTO, SJTOO
S	SE, SO, SOO, ST, STO, STOO

- Este dispositivo cumple con lo estipulado en la Parte 15 de las Normativas de la FCC. La operación está sujeta a las dos condiciones siguientes: (1) este dispositivo no puede provocar interferencias nocivas, y (2) este dispositivo debe aceptar las interferencias recibidas, incluidas las interferencias que puedan provocar un funcionamiento no deseado.

■ FOR CANADIAN USERS

- This Class B digital apparatus complies with Canadian ICES-003.

■ FOR EU USERS

The symbol mark and recycling systems described below apply to EU countries and do not apply to countries in other areas of the world.

Your SANYO product is designed and manufactured with high quality materials and components which can be recycled and/or reused.

The symbol mark means that electrical and electronic equipment, batteries and accumulators, at their end-of-life, should be disposed of separately from your household waste.

Note:

If a chemical symbol is printed beneath the symbol mark, this chemical symbol means that the battery or accumulator contains a heavy metal at a certain concentration. This will be indicated as follows: Hg: mercury, Cd: cadmium, Pb: lead

In the European Union there are separate collection systems for used electrical and electronic equipment, batteries and accumulators.

Please, dispose of them correctly at your local community waste collection/ recycling centre.

Please, help us to conserve the environment we live in!



SANYO Sales & Marketing Europe GmbH

Stahlgruberring 4, D-81829 München, Germany

SANYO Electric Co., Ltd.

1-1, Sanyo-cho, Daito City, Osaka 574-8534, Japan

■ FOR RUSSIAN USERS



AP46

This product is certified by an official certification company which is authorized by the Russian Federation.

HOW TO READ THIS MANUAL

For first-time users

Please read this manual to familiarize yourself with your camera's operation.



To use the various camera features

The Instruction Manual that explains the features in detail can be obtained from our website (page 45).



To use additional features

Visit the Sanyo website to learn how to adjust the camera settings for various shooting scenes. There you'll also find information about the software for playing back data recorded with your camera and for burning (recording) DVDs.

You may find the answers to questions or problems concerning camera operation in the sections "COMMONLY ASKED QUESTIONS" (page 51).

Symbols used in this manual

- HINT** Points giving some extended instructions or special points to pay attention to.
- CAUTION** Points that require special attention.
- (page xx)** Refer to the page indicated for detailed information.

SHOOT, PLAY BACK AND SAVE

Preparing the camera

1 Insert the battery pack.

① Open the monitor unit.

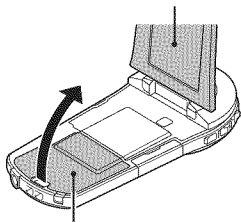

② Open the battery cover.

③ Insert the battery pack.

*The battery must be correctly oriented in relation to the terminals.

④ Close the battery cover.

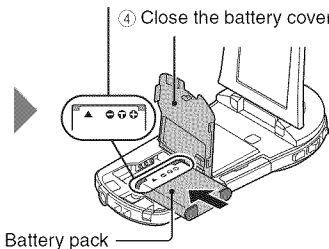

2 Insert the SD Memory Card.

- An SD Memory Card is not included with your camera. Please purchase a commercially sold card.
- In this manual, the SD Memory Card is referred to as the "card".

② Insert the card.

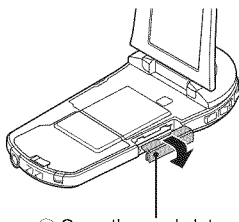

① Open the card slot cover.

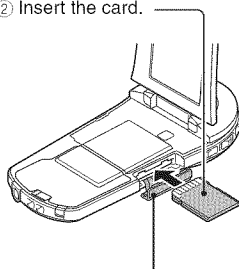

③ Close the card slot cover.

Shooting



- 1** Press the **ON/OFF** button for at least 1 second to turn the camera on.

- If the screen to set the date and time appears, press the **MENU** button 2 times to cancel it.

For how to set the date and time, see page 22.

- 2** Record.

To record a video clip:

- Press the [] button to begin recording a video clip.
- Press the [] button again to end the recording.

To take a photo:

- Press the [] button.
- A still image is captured.

ON/OFF button
MENU button

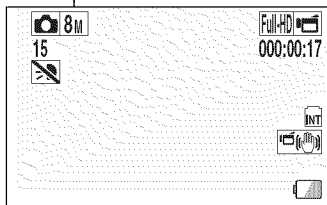
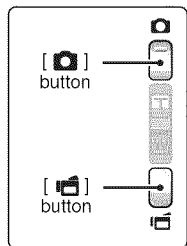
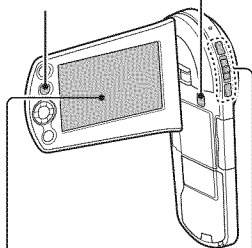

Before capturing those important shots, be sure to first take a test shot to confirm that your camera is set up and ready to go

- Sanyo declines any claim for compensation for recorded contents etc. in case of photographing or recording failure due to a chance camera or card flaw.

Playback

1 Press the REC/PLAY button.

- The display changes to the Playback Screen.

2 Select the image to play back.

- Use the arrow keys to move the orange frame to the image you wish to play back.
- The image information for the framed image is shown in the bottom part of the monitor.

3 Press the SET button.

- Playback begins.
- <To return to the recording mode>**
- Press the REC/PLAY button.

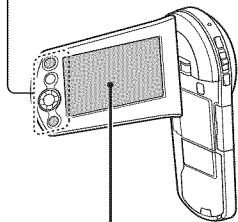
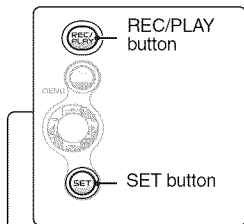

Deleting files

1 On the screen in step 2, move the orange frame to the file you wish to delete, and press the MENU button.

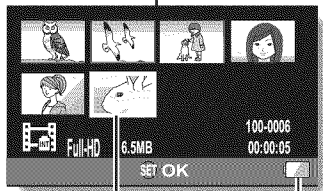

Orange frame

Remaining battery
power indication

2 Select “DELETE”, and press the SET button.

3 Select “DELETE SINGLE”, and press the SET button.

4 Select “DELETE”, and press the SET button.

- If you press [◀] or [▶], the screen to delete a different file will appear.

5 When you are finished deleting files, press the MENU button.

- Pressing the MENU button 3 times will return you to the screen in step 2.

When you are finished using the camera...

Press the ON/OFF button for at least 1 second to turn the camera off.

To continue to the next operation...

Please confirm that your computer is connected to the Internet.

Burn your recorded video clips onto a DVD

Using the supplied CD-ROM (Xacti Software CD), you can store your captured images on a DVD.

Install application program

- 1 Set the supplied CD-ROM in your computer's DVD drive.**
 - The installation window opens.
 - 2 Click on [TotalMedia Extreme for SANYO].**
 - After clicking on the application program, follow the instructions shown on the monitor to install the program.
 - When the window appears requesting to restart your computer, click the [Finish] button to reboot.
 - 3 Remove the CD-ROM from the computer's DVD drive.**
 - <About the Kodak online service>**
 - When the installation window closes, a dialog box to connect to the website introducing Kodak's online service appears. Check the [No thanks !] option button, and then click on the [OK] button.
-

Copy data from your camera to the computer

Connect your camera to a computer, and copy the desired data to the computer.

1 Turn on the computer, and use the supplied dedicated USB interface cable to connect your camera to the computer.

- Connect the cable between the camera's USB/AV terminal and the computer's USB connector.

2 Turn on the camera (page 19).

- The USB Connection Screen appears on the camera's monitor.

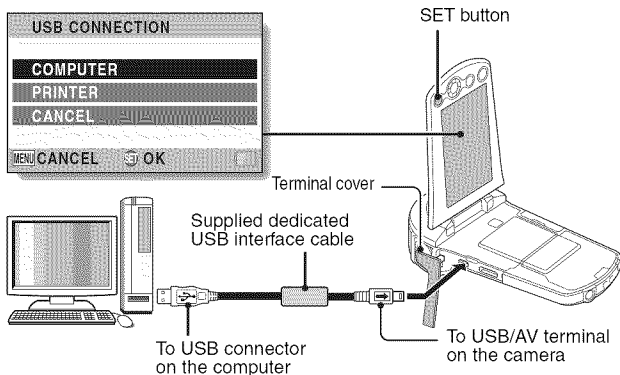

3 Select “COMPUTER”, and press the SET button.

- The screen to select the computer connection mode appears.

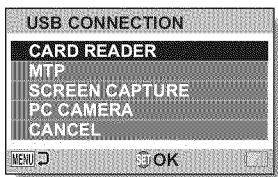

4 Select “CARD READER”, and press the SET button.

5 Copy data from your camera to a computer.

- The CD-ROM (Xacti Software CD) includes “TotalMedia Extreme for SANYO” with which photo and video files can be imported en bloc.

HINT

How to open the terminal cover

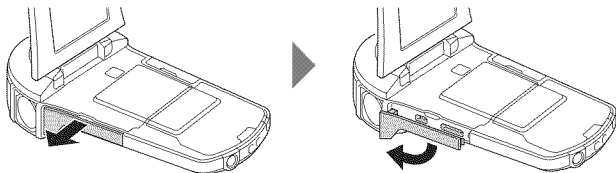

Burn video clips onto a DVD (for Windows Vista users)

Here's how to write your recorded data onto a DVD in the MPEG2 format. For information on other operations, please see the Help file for TotalMedia Extreme.

1 Insert a blank DVD in your computer's DVD drive.

2 Double-click the desktop [TotalMedia Extreme for SANYO] icon.

- TotalMedia Extreme for SANYO is launched, and the startup page appears.

[Create video] icon



- 3** Click the [Create video] icon.
- The TotalMedia Studio screen appears.

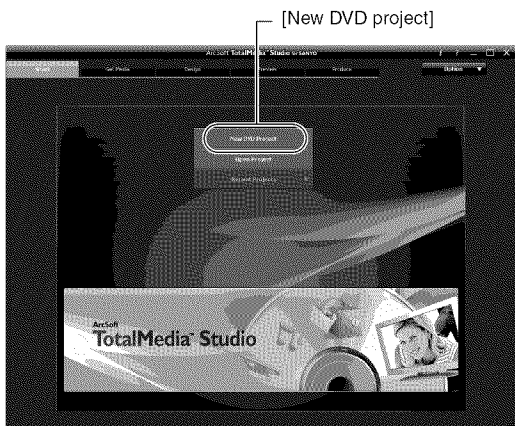

4 Click [New DVD project].

- The screen to create a video clip to burn to DVD appears.



5 Click [Insert video].

- The screen to select the video clip file to burn to DVD appears.
- Click on the file you wish to burn to DVD.
- To select multiple files, keep the [Ctrl] key pressed while selecting files.

6 Click the [Open] button.

- The files you selected in step 5 and the total size of the files to burn to DVD are shown in the lower part of the window.

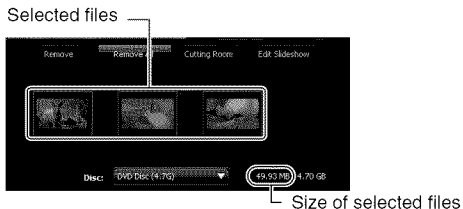

7 Click the [Design] tab.

- The screen to design the title menu that is shown when the DVD is played appears.
- Select one of the designs.



8 Click the [Produce] tab.

- The screen to burn files to the DVD appears.



[Burn] button

9 Click the [Burn] button.

- A window appears asking if you wish to save the project.
- Saving the project will save your settings from steps 5 through 7.
- It is recommended that you save the project if you intend to again edit the same video clips that you burned to DVD.

10 Click the [Yes] button.

- The screen to save the project appears.
- Assign a suitable file name for the project.

11 Click the [Save] button.

- The current project is saved, and the DVD burn process begins.
- When the burn process is completed, a window appears to inform you that the process is done. Remove the DVD from the computer's DVD drive.

12 Click the [OK] button.

- You are returned to the screen to burn files to DVD.

13 Click the [X] close button in the upper right corner.

- You are returned to the top page.

14 Click the [X] close button in the upper right corner.

- TotalMedia Extreme for SANYO is exited.

HINT

About software upgrades

- For information concerning TotalMedia Extreme upgrades, please go to the following website:
<http://www.arcsoft.com/en-us/index.asp>
 - If TotalMedia Extreme is launched while you are connected to the Internet, automatic program update notifications may appear.

To use Blu-ray Disc or AVCHD

- The version of TotalMedia Extreme that accompanies your camera cannot be used to burn these formats. To purchase a different version, please refer to the following website.
<http://sanyo.com/xacti/english/>

CAUTION

Does the window requesting confirmation to enable the MPEG-2 Codec appear?

When using TotalMedia Extreme for the first time, a window requesting you to confirm activation of the MPEG-2 Codec appears during the procedure. The MPEG-2 Codec must be activated in order to burn files to a DVD. Complete the following procedure to activate the MPEG-2 Codec.

- Note that your computer must be connected to the Internet in order to complete this procedure. Please confirm that your computer is connected to the Internet.
- ① **When the window requesting confirmation to activate the MPEG-2 Codec appears, click the [Yes] button.**
 - The ArcSoft website appears.
 - ② **Click on [Special downloads].**
 - The window appears for you to enter your email address, name, license ID, etc.
 - Enter the correct information.
 - The license ID is located on the back card of the supplied CD-ROM.
 - ③ **Click the [Submit] button.**
 - Soon thereafter, the URL for the download to activate the MPEG-2 Codec will be sent to the email address you entered in step ②.
 - ④ **Click the download URL link.**
 - The program will be downloaded to your computer.
 - ⑤ **Double-click the icon for the downloaded program.**
 - Follow the instructions to activate the MPEG-2 Codec.
 - DVD burning via the TotalMedia Extreme program is now enabled.
 - When the procedure above has been completed, continue to the procedure to burn to DVD.

United States/Canada

Tel: +1-510-979-5599

Web: <http://www.arcsoft.com/support/>

E-mail Support: [http://www.arcsoft.com/public/
content_page.asp?pageID=83](http://www.arcsoft.com/public/content_page.asp?pageID=83)

Hours: M-F from 9:00am - 5:00pm

(Pacific Standard Time, excluding holidays observed by ArcSoft)

Language: English

Europe

Tel: +353 (0) 61-702087

Web: <http://www.arcsoft.com/en/support>

Email Support: eurosupport@arcsoft.com

Hours: M-Th from 8:30am - 5:30pm GMT

(excluding holidays observed by ArcSoft's Affiliate)

F from 8:30am - 5:00pm GMT

(excluding holidays observed by ArcSoft's Affiliate)

(Adjusted for daylight savings time when applicable)

Language: English, French, Italian, German, Spanish and Dutch

China

Tel: +86 (0) 571-88210575

Web: <http://www.arcsoft.com.cn/support>

E-Mail Support: support@arcsoft.com.cn

Hours: M-F 8:30am-5:30pm

(Beijing local time) (excluding holidays observed by ArcSoft)

Language: Chinese

CONTENTS

HOW TO READ THIS MANUAL	v
CHECKING THE INCLUDED ACCESSORIES	3
How to use the accessories	5
ABOUT THE CARD	7
Media cards that can be used with this camera	7
What "card" means in this manual	7

■ SETUP

PARTS NAMES	8
CHARGING THE BATTERY PACK	10
Charging the battery pack	11
INSTALLING THE CARD	13
INSTALLING THE BATTERY PACK	15
Installing the DC adaptor (sold separately: VAR-A3U/A3EX)	16
About the temperature alert icon 	18
TURNING THE CAMERA ON AND OFF	19
Turning on the camera	19
Turning off the camera	19
Turning on the camera when the power save (sleep) mode is active	20
DATE AND TIME SETTING	22
SWITCHING BETWEEN THE RECORDING MODE AND PLAYBACK MODE	25
SWITCHING THE OPERATING MODE	26
Switching between the SIMPLE and NORMAL modes	26
Accessing/exiting the SIMPLE/NORMAL Mode Menu Screen	27

■ SHOOTING

VIDEO CLIP RECORDING	31
SHOOTING SINGLE SHOTS	32
Using the LED light	34
SHOOT A STILL IMAGE WHILE RECORDING A VIDEO CLIP	36
MACRO-PHOTOGRAPHY (ZOOM)	38

■ **PLAYBACK**

PLAYING BACK VIDEO CLIPS AND STILL IMAGES	39
How to save one frame from a video clip as a still image	41

■ **CONNECTING TO A TV**

CONNECTING TO A TV	42
Connecting to a video input terminal	43
Connecting to the HDMI terminal	43
PLAYING BACK ON A TV	44

■ **OBTAINING THE INSTRUCTION MANUAL**

OBTAINING THE INSTRUCTION MANUAL	45
Contents of the Instruction Manual	45
How to obtain the Instruction Manual	49

■ **ABOUT THE EYE-FI TRANSFER FEATURE**

About the Eye-Fi transfer feature	50
---	----

■ **APPENDICES**

COMMONLY ASKED QUESTIONS	51
SPECIFICATIONS	59
Camera	59
Camera connectors	63
Battery life	63
Possible No. of Images/Possible Shooting Time/ Possible Recording Time	64
Concerning the multi-indicator	65
Supplied battery pack charger	66
Supplied Li-ion battery pack	66
Others	67
Before capturing those important shots, be sure to first take a test shot to confirm that your camera is set up and ready to go	68

CHECKING THE INCLUDED ACCESSORIES

- Xacti Software CD (CD-ROM)
(page x): 1



- Li-ion battery pack: 1

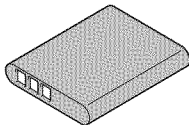

- Lithium-ion battery pack
charger and power cord: 1

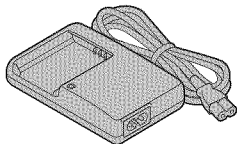

- Dedicated USB interface
cable (page xi): 1

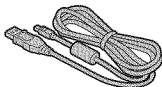

- Dedicated AV interface cable
(page 43): 1

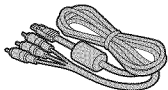

- Handstrap (page 5): 1

* To prevent from dropping the camera, be sure to attach the handstrap.

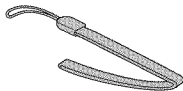

- Lens cap (page 6): 1

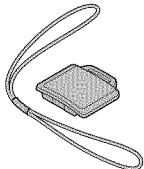

- GUIDE FOR BASIC
OPERATION

- **SAFETY MANUAL**
(safety precautions booklet)
Please read this booklet
carefully before using the
camera.



- **QUICK GUIDE**



How to use the accessories

■ Handstrap

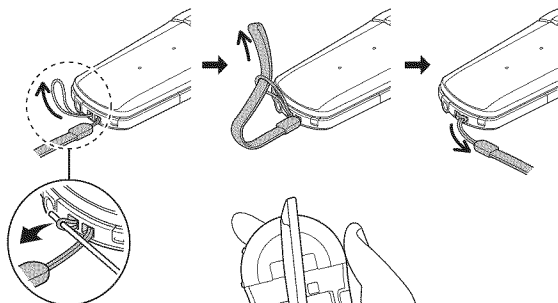

If it is difficult to thread the loop through the eyelet, use a fine-tipped object to pull it through.

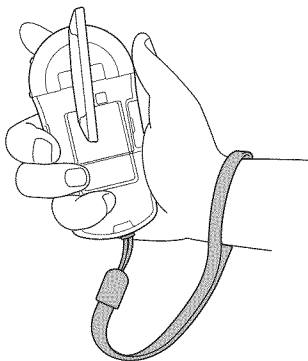

■ How to attach the lens cap

①

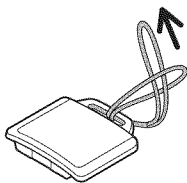

②



③

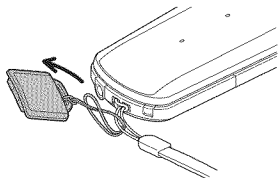

④

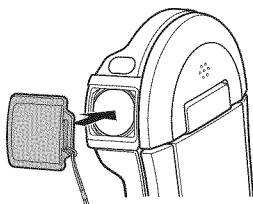

ABOUT THE CARD

Media cards that can be used with this camera

The type of card that can be inserted into and used with this camera is:

- SD Memory Card
- SDHC Memory Card
- SDXC Memory Card

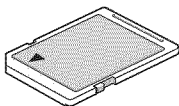

What “card” means in this manual

- In this manual, SD Memory Cards, SDHC Memory Cards and SDXC Memory Cards that can be used in this dual camera are referred to as “card”.

PARTS NAMES

Front

LED light unit

- In contrast to a flash, the LED light does not emit a strong light. It is useful for illuminating subjects when taking macro (close-up) shots.

Lens

Terminal cover

Monitor unit

Stereo microphone

Battery cover

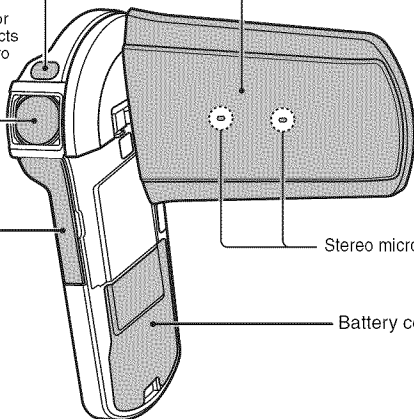

Bottom

Cover for DC adaptor (optional) connection

Strap holder

Tripod stand hole

- Affix the camera to the tripod before opening the monitor unit.
- When closing the monitor unit, be sure to first detach it from the tripod.

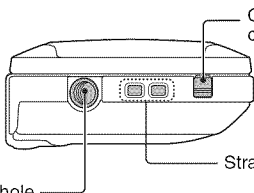

Rear

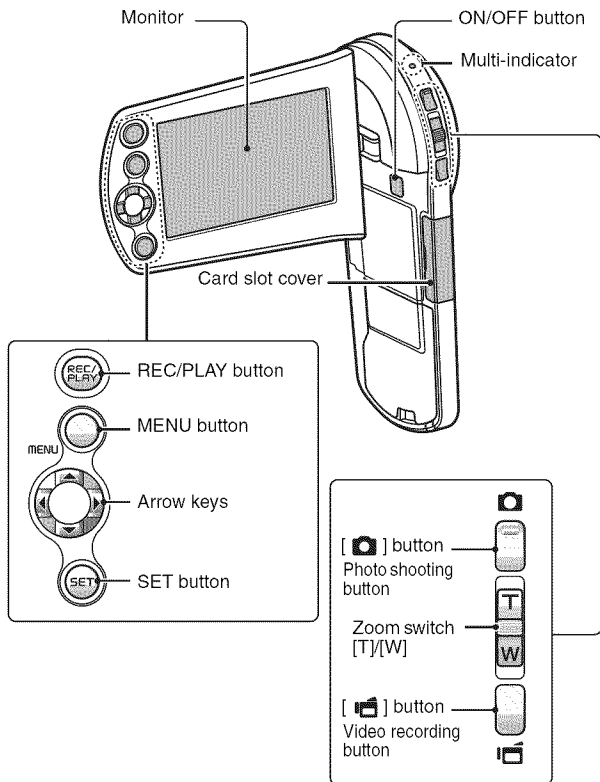

CHARGING THE BATTERY PACK

Please charge the supplied battery pack before using it.

1 Connect the supplied power cord to the socket on the battery pack charger.

- Insert the connector straight and securely.

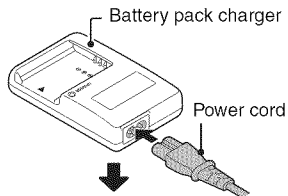

2 Insert the battery pack in the battery charger.

- Insert it in the direction indicated by the [Δ] mark on the battery pack.

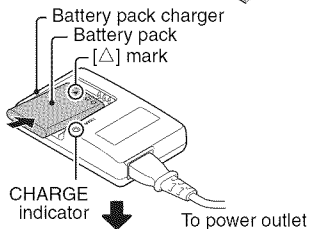

3 Plug the power plug into a power outlet (AC 100 V to 240 V).

- Charging begins.
- The CHARGE indicator is lit during charging.

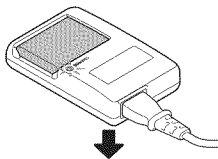

4 When the CHARGE indicator turns off, unplug the power cord from the power outlet, and remove the battery pack from the charger.

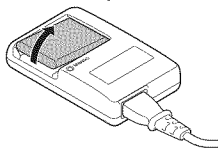

HINT

- Charging takes approximately 120 min.

Charging the battery pack

Be sure to fully charge the supplied or separately sold battery pack before using it in your camera. For charging the battery pack, use the supplied charger.

Charge the battery pack if it is being used for the first time, and recharge it whenever the remaining charge is low.

Does the battery pack feel hot?

- During charging, the charger and battery pack will be warm. This is normal and does not indicate a malfunction.

If there is interference to your TV or radio during charging...

- Move the battery pack and charger further away from the TV or radio.

Ambient temperature during charging

- It is recommended that the ambient temperature during charging be between about 10 °C and 35 °C (50 °F and 95 °F). Due to the characteristics of the battery pack, at temperatures below 0 °C (32 °F), it may not be possible to sufficiently charge it.
- When the battery pack temperature is high, the safety function may be activated and halt charging.

Charge a battery pack in the following cases

- A battery pack which has not been used for a long time
- Newly purchased battery pack

FOR AMERICAN USERS:

- Use a UL Listed, 1.8 to 3 m (6 to 10 ft.), Type SPT-2 or NiSPT-2, AWG No.18 power supply cord, rated for 125 V 7 A, with a non-polarized NEMA 1-15P plug rated for 125 V 15 A.

About the CHARGE indicator

The CHARGE indicator shows the status of the battery pack and the charger. Please refer to the following table if the indicator flashes abnormally.

CHARGE indicator	
Not lit	Not connected properly <ul style="list-style-type: none">• To recharge the battery pack, the power cord of the charger must be connected to a power outlet, and the plug at the other end inserted in the charger's power socket (page 10).• The battery pack is not installed, or it is not installed correctly (page 10). Charging finished
Lit	Charging
Flashing	Problem with the battery pack or battery pack charger <ul style="list-style-type: none">• Immediately remove the battery pack from the charger.• Do not use an abnormal battery pack. (The usable life of the battery pack has probably expired.)

CAUTION

Do not charge the battery pack immediately after the camera has been in continuous use for a long time

- The battery pack becomes hot when the camera is used continuously for a long time. If you attempt to charge the battery pack in this state, the safety function may be activated and it may not be possible to charge the battery pack. Wait until the battery pack has cooled down before attempting to charge it.

INSTALLING THE CARD

Be sure to format a newly purchased card or one that was used in another device before using it in your camera (page 14). If an unformatted card is used, the card itself may become unusable.

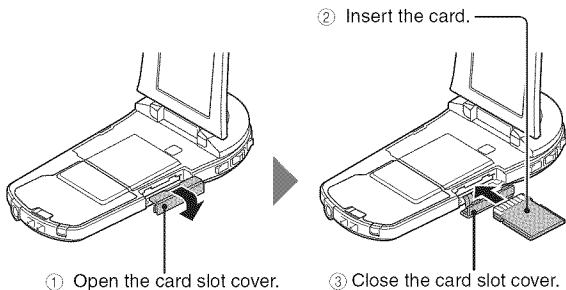

<When removing the card...>

- To remove the card, press it in, and then release. The card will protrude slightly, and you can then pull it out.

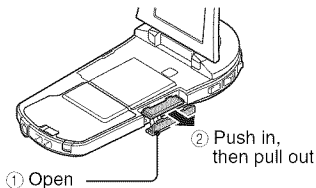

CAUTION**Do not attempt to forcibly remove the card**

- Doing so may damage the card or the stored files.

If the multi-indicator is flashing red...

- Never remove the card when the multi-indicator is flashing red, as doing so may result in loss of files stored in the card.

HINT**To format a card**

- ① Insert the card in the camera, and press the ON/OFF button (pages 13 and 19).
- ② Set the camera to the NORMAL mode (page 26).
- ③ Press the MENU button.
- ④ Select the [] tab, and press the SET button.
- ⑤ Select "FORMAT" and press the SET button.
 - The Format Screen appears. Follow the instructions on the screen to format the card.

Shooting without a card installed

- When a card is installed, images are recorded to and played back from the card. When no card is installed, images are recorded to and played back from the camera's internal memory. When the camera is turned on with no card installed, the internal memory icon  is shown on the monitor to let you know that the images you capture will be saved to the camera's internal memory.

INSTALLING THE BATTERY PACK

Please charge the supplied battery pack before using it.

- ① Open the monitor unit.

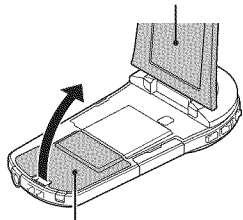

- ② Open the battery cover.

- ③ Insert the battery pack.
*The battery must be correctly oriented in relation to the terminals.

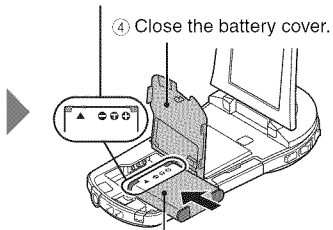

- ④ Close the battery cover.

Installing the DC adaptor (sold separately: VAR-A3U/A3EX)

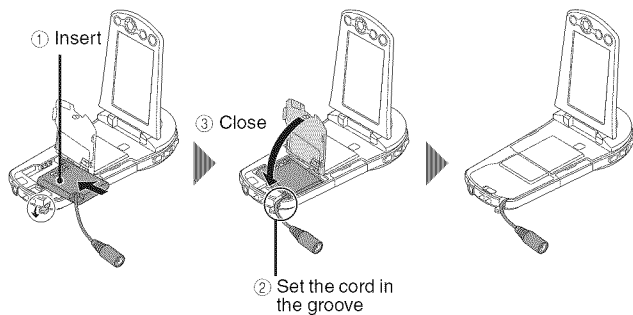

CAUTION

Does the battery pack appear swollen?

- The lithium-ion battery used in this camera may expand slightly when stored in a hot environment or repeatedly used, but this is not a safety hazard. However, a battery that is difficult to insert because it has become swollen may then be impossible to extract from the battery compartment. In this case, please discontinue its use and replace it with a new battery.

Do not use the battery with the outer covering or label removed

- Doing so may result in malfunction.

HINT

About the internal backup battery

- This camera's internal battery serves to maintain the date and time settings, as well as the shooting settings. The backup battery will be fully charged when the battery pack is kept in the camera continuously for about 2 days. In the fully charged state, the backup battery will maintain the camera settings for about 7 days.

When not using the camera for a long time, remove the battery pack

- A small amount of power is still used even if the camera is turned off, and it is therefore recommended that the battery pack be removed from the camera if it is not going to be used for a long time. Note that when the battery pack is removed for a long period, the time and date settings may be cleared. Before using your camera again, be sure to confirm that the camera settings are correct.







To prolong the life of the battery pack

- Although the battery pack is an expendable item, you can maximize the life of the battery by heeding the following suggestions.
 - Do not leave the battery under the hot summer sun or exposed to other high-temperature environments.
 - Do not continually recharge the battery when it is already fully charged. After fully charging it once, for example, use it for a while to partially discharge it before recharging it again.
 - When the battery is not to be used for a long time, if possible store the partially charged (not fully charged) battery in a cool environment.

About the temperature alert icon

During camera use, if the temperature of the battery or inside the camera (excluding the battery) rises, a temperature alert icon  will appear as described below.

■ When the battery or internal camera (excluding battery) temperature rises during use

- During camera use, if the temperature of the battery or inside the camera (excluding the battery) rises, a  icon lights on the monitor. It is still possible to record and play back even when the  icon is lit; however it is advised that you discontinue use as soon as possible and turn the camera off.
- If the temperature rises further, the  icon will start to flash, and the camera will turn off automatically.
The camera cannot be turned on until the temperature has dropped (or as long as the  icon remains flashing). Please wait until the temperature has dropped before resuming use.
- During video recording, a countdown indicator will show the time starting about 15 seconds before shutdown. When the indicator shows 0 seconds, recording stops.
- If the camera is turned off while the temperature is high (that is, while the  icon is flashing), it cannot be turned on again until the temperature has dropped (or as long as the  icon remains flashing).

TURNING THE CAMERA ON AND OFF

Turning on the camera

- 1 Open the monitor unit, and press the ON/OFF button for at least 1 second.
 - If you briefly press the ON/OFF button, once, the camera will switch to the power save mode.

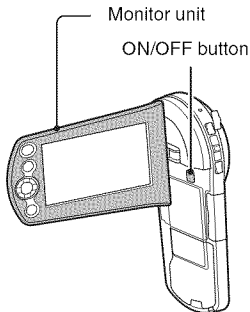

Turning off the camera

- 1 Press the ON/OFF button for at least 1 second.
 - The camera turns off.

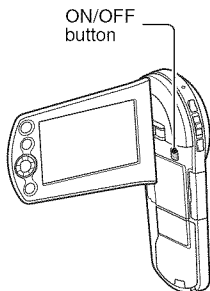

Turning on the camera when the power save (sleep) mode is active

In order to preserve battery pack power, the power save (sleep) function will automatically turn off the camera after about 1 minute of no use during shooting, or about 5 minutes of no use during playback (factory-preset setting).

- When the power save mode is active, you can restore the power by any of the following methods:
 - **Press the ON/OFF button.**
 - **Press the [] button.**
 - **Open the monitor unit.**
- After the power save mode has been active for about 1 hour, the camera will switch to the standby mode. In this case, you can restore the power by pressing the ON/OFF button, or by closing and then opening the monitor unit.
- When the AC adaptor is connected, the power save mode will become active about 5 minutes after the camera is turned on (factory-preset setting).
- When the camera is connected to a computer or printer, the power save mode becomes active after about 12 hours.



HINT

To immediately activate the power save mode

- Press the ON/OFF button briefly to activate the power save function.

About the standby mode

- To turn off the camera only briefly, you can close the monitor unit to put the camera in the standby mode. The standby mode uses almost no power. When the monitor unit is opened again, the camera turns on immediately and you are ready to shoot or view images without any delay.

CAUTION

If the icon appears...

- When a picture is taken, the date and time it was captured are recorded with it. If the date and time settings have not been completed (page 22), the date and time cannot be recorded with the captured images. For this reason, immediately after the camera is turned on, the “Set date and time” reminder briefly appears, after which the  icon is shown on the Recording Screen. To have the date and time recorded with the images, please complete this setting before capturing images.

<Caution>

- Due to the characteristics of the camera, the outer surface may become warm during use, but this does not indicate a malfunction.
- If the camera starts to feel uncomfortably hot during use, you might temporarily discontinue use until it cools down, or try holding it in your other hand for a while.
Please use a tripod or other support when using the camera for a long time.

DATE AND TIME SETTING

The camera will record the date and time an image or audio recording is taken so that you can display them during playback. Therefore, before capturing images, make sure the correct date and time are set.

- To correct the date and time setting, please see under **HINT** on page 24.

Example: To set the clock to 7:30 p.m. on December 24, 2010

1 Turn on the camera (page 19), and press the SET button.

- The Clock Set Screen appears.
- Follow the procedures below to enable or disable the date display during playback, to set the display format for the date, and to set the date and time.
- To display the Recording or Playback Screen, press the MENU button 2 times.

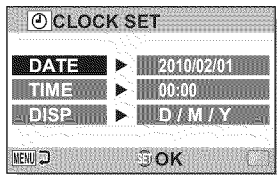

SETUP

2 Set the date.

- ① Select "DATE".
- ② Press the SET button.
 - The Set Date Screen appears.
- ③ Set the date to "2010/12/24".
 - The date is set in the following order: Set the year → Set the month → Set the day.
 - Press [◀] or [▶] to select year, month or day. Press [▲] or [▼] to increase or decrease the number.
- ④ Press the SET button.

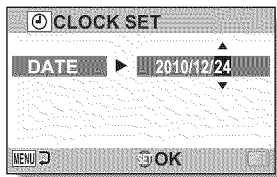

3 Set the clock.

- ① Select "TIME".
- ② Press the SET button.
 - The Set Time Screen appears.
- ③ Set the time to "19:30".
 - The time is set in the following order: Set the hour → Set the minute.
 - A 24-hour clock is used for the time display.
- ④ Press the SET button.

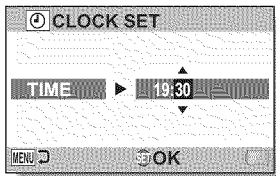

4 Set the order in which the date is displayed during playback.

- ① Select "DISP".
- ② Press the SET button.
 - The Set Date Format Screen appears.
- ③ Press [▲] or [▼].
 - Press [▲] to change the displayed date order as follows:

→ D / M / Y → Y / M / D → M / D / Y →

Press [▼] to change it in the reverse order.

- ④ Press the SET button.

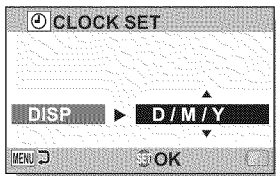

5 Press the MENU button.

- The date and time setting is completed.
- To display the Recording or Playback Screen, press the MENU button.

HINT

- Under normal conditions, while the battery pack is being replaced, an internal battery will maintain the date and time settings. However, there is a small chance the settings may be lost (the backup will last for about 7 days). It is recommended to check that the date and time settings are still correct after replacing the battery pack and before shooting or recording of any type (follow step 1).

To correct the date and time settings

- ① Turn on the camera.
- ② Display the Option Setting Menu 1 (page 29).
- ③ Select "CLOCK SET" and press the SET button.
 - The screen to set the date and time appears.
 - The current date and time settings are shown.
- ④ Select the line you wish to change, and make the correction.



SWITCHING BETWEEN THE RECORDING MODE AND PLAYBACK MODE

Switch between the recording mode (for recording) and the playback mode (for viewing your recorded images).

1 Turn on the camera (page 19).

2 Press the REC/PLAY button.

- The mode changes.
- The mode changes each time the REC/PLAY button is pressed.

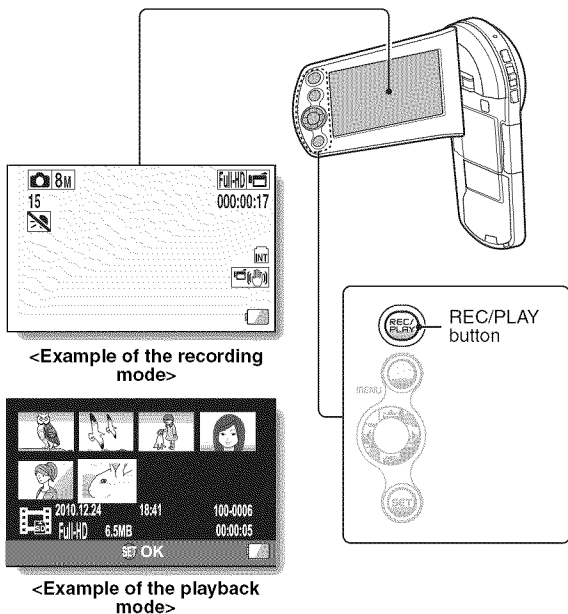

SWITCHING THE OPERATING MODE

The “SIMPLE mode” comprises only those functions that are most often used and necessary to operate the camera, while the “NORMAL mode” enables full use of all the camera's many functions. Select the mode that is suitable for your purposes.

Switching between the SIMPLE and NORMAL modes

- 1 Turn on the camera (page 19).**
 - The previous mode is active.
- 2 Press the MENU button.**
 - The Menu Screen for the active mode appears.

- 3 Select the operating mode icon, and press the SET button.**

- Switch from the SIMPLE mode to the NORMAL mode, or from the NORMAL mode to the SIMPLE mode.
- Press the MENU button to cancel the Menu Screen.

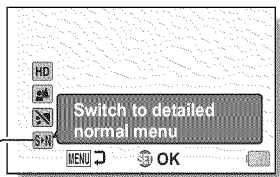

Operating mode icon

<SIMPLE Mode Menu Screen>

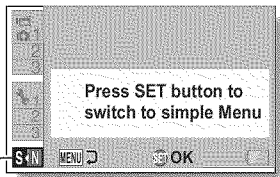

Operating mode icon

<NORMAL Mode Menu Screen>

Accessing/exiting the SIMPLE/NORMAL Mode Menu Screen

- 1 Set the camera to the recording or playback mode (page 25).
- 2 Select the desired operating mode (page 26).
- 3 If the Menu Screen is not displayed, press the MENU button.
 - The Menu Screen appears.
 - To cancel the Menu Screen, press the MENU button.

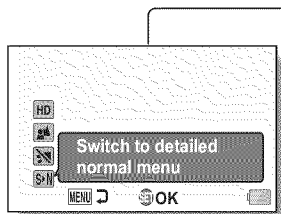

<Example: SIMPLE Mode Recording Menu>



<Example: NORMAL Mode Recording Menu>

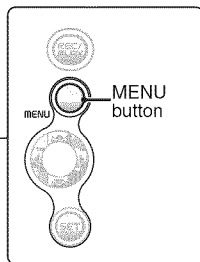
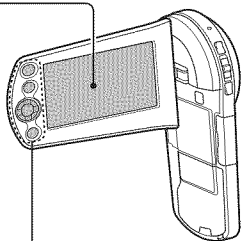

Using the SIMPLE Mode Menu

- 4** Press [▲] or [▼] to select the item you wish to change, and press the SET button.
- The Setting Screen for the selected item appears.

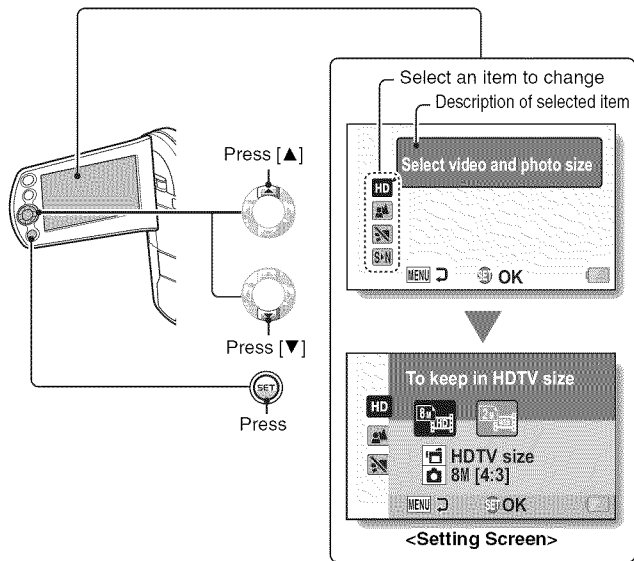

6 Press [▲] or [▼] to select the item you wish to change, and press the SET button.

- The Setting Screen for the selected item appears.
- To return to the Menu Screen, press the MENU button.

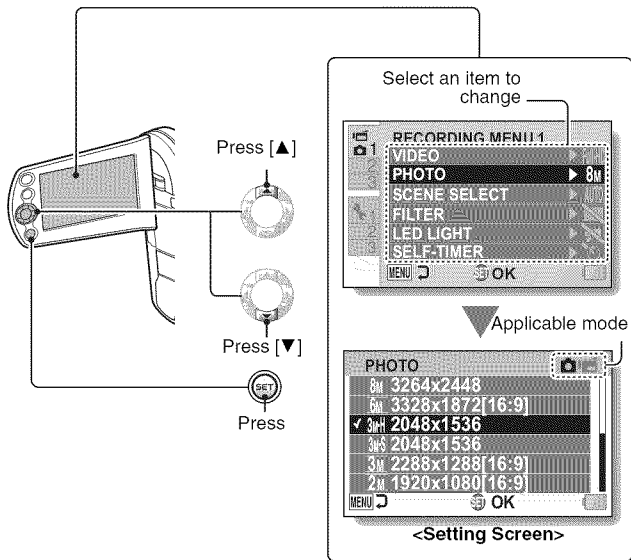

HINT

About the applicable mode indicator

- This indicator shows the shooting mode(s) for which the selected setting is effective.

: This setting is effective during still image shooting.

: This setting is effective during video clip recording.

: This setting is effective during still image shooting and video clip recording.

VIDEO CLIP RECORDING

- 1 Turn on the camera (page 19), and set it to the recording mode (page 25).

- 2 Press the [] button.

- Recording begins.
- It is not necessary to keep the [] button pressed while recording.
- When the remaining recording time available for the currently recording clip becomes little, a countdown of the remaining recording time appears on the display.

- 3 End the recording.

- Press the [] button again to stop recording.

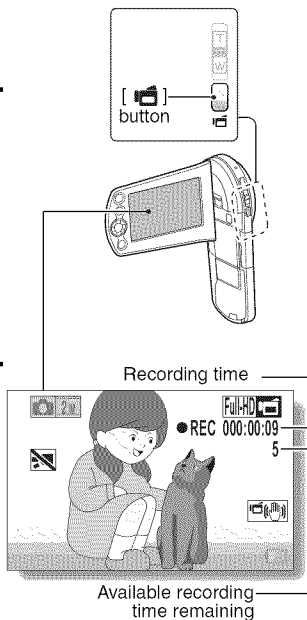

SHOOTING SINGLE SHOTS

Capture a still image (single-shot).

- 1 Turn on the camera (page 19), and set it to the recording mode (page 25).

- 2 Press the [] button.

- ① Press the [] button halfway.

- The autofocus operates, and the image is focused (focus lock).

- ② Continue to gently press the [] button all the way.

- The shutter releases and the image is captured.
- You can view the captured image on the monitor by keeping the [] button depressed when you capture the image.

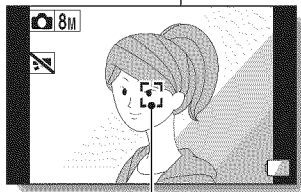
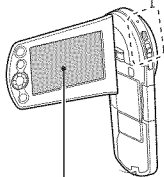
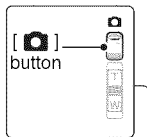
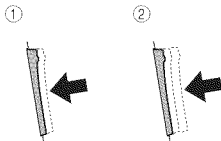

Target mark

HINT

Adjusting the monitor brightness



- While the Recording Screen is active, you can quickly access the screen for adjusting the brightness of the monitor by pressing the MENU button for at least 1 second.

What is the camera focusing on?

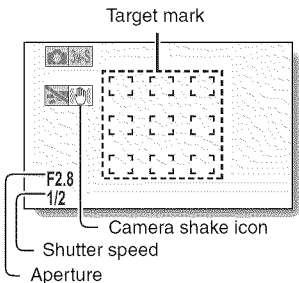
- A target mark  on the monitor shows the area the camera is focusing on.
- The camera automatically determines the correct focus by measuring from 9 different focus points within the shooting area. If the target mark is at a position that is different from the point you wish to focus on, you can refocus, for example, by changing the shooting angle.
- The large target mark appears when the camera focuses on a wide area in the center of the screen.



The focus and exposure can be locked (in the NORMAL mode)

- By assigning an operation shortcut to an arrow key (page 45), you can set the autofocus or the exposure to a fixed setting. When the exposure setting is fixed, the  icon appears on the monitor; when the autofocus setting is fixed, the  icon appears on the monitor.
- When the focus range (page 45) setting or scene select setting is changed, the focus lock is released.

The shutter speed and aperture are displayed (in the NORMAL mode)

- The shutter speed and aperture settings are shown on the Recording Screen. You can use them as a reference when shooting.

If the camera shake icon appears... (in the NORMAL mode)

- During still image shooting, if the shutter speed is slow and the possibility that the image may be blurred due to camera shake becomes high, the camera shake icon may appear on the monitor. In this case, use a tripod to stabilize the camera when shooting.
- When shooting with the scene select function set to the fireworks  mode, the camera shake icon always appears, but this is normal.

Does it seem to take a long time to save images?

- When shooting in dimly lit conditions, it may take some time to save the data to the card.

Using the LED light

The LED light can be used for macro photography to illuminate close-up subjects in dimly lit surroundings.

When using the LED light, set the focus range (page 45) to super macro .

- 1 Display the SIMPLE Mode Recording Menu (page 27), select the LED light setting, and press the SET button.

- The screen to select the LED light operation appears.

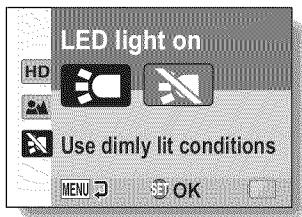

: The LED light operates regardless of the shooting conditions.

: The LED light is disabled regardless of the shooting conditions.

- 2 Select the desired LED light operation, and press the SET button.

- This completes the LED light operation setting.

- 3 Press the [] button to take the picture or the [] button to begin recording.

CAUTION

Is the recorded image dark?

- In contrast to a flash, the LED light does not emit a strong light. It is useful for illuminating subjects when taking macro (close-up) shots.
- When the LED light is used, the edges of the captured image may appear dark.

Do not touch the LED light unit when shooting

- The LED light becomes very hot and may cause a burn. Avoid touching the LED light when shooting.



HINT

About using the LED light

- The LED light turns off after about 8 minutes.
- A video clip using the LED light continuously can be recorded for about 8 minutes. About 30 seconds before recording ends, a countdown display is shown in the monitor.
- By assigning an operation shortcut to an arrow key (page 45), you will be able to change the LED light mode from the Recording Screen (in the NORMAL mode).

SHOOT A STILL IMAGE WHILE RECORDING A VIDEO CLIP

You can capture a still image (a single-shot) while recording a video clip.

- 1** Turn on the camera (page 19), and set it to the recording mode (page 25).
- 2** Press the [] button.
- 3** When you see a scene you'd like to capture as a still image, press the [] button.
- 4** Press the [] button to end the video clip recording.

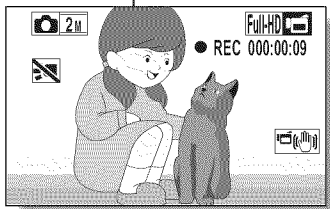
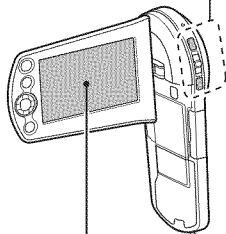
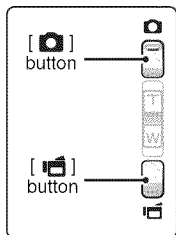

HINT

- When the remaining video recording time becomes approximately 50 seconds, it will no longer be possible to capture a still image while recording a video clip. The exact remaining recording time at which this occurs will differ depending on the subject and on the recording size (page 45), as well as on the video clip recording mode (page 45). If you intend to capture a still image while recording a video clip, it is suggested that you take note of the remaining video recording time.

About the recording size of still images

- The size of a still image captured during video clip recording depends on the video clip recording size.

Video clip recording size setting	Still image recording size
Full-HD Full-SHQ	2M
HD-HR HD-SHQ	0.9M
TV-SHQ	0.3M

- It is not possible to capture a still image when recording a video clip in the ☆ mode.
- It is not possible to capture sequential shots.

MACRO-PHOTOGRAPHY (ZOOM)

Your camera has two zoom functions: optical zoom and digital zoom.

1 Point the camera lens at the subject.

2 Push the zoom switch toward [T/🔍] or [W/📐] to compose the desired image.

[T/🔍]: Zoom in on the subject.

[W/📐]: Zoom out.

- When the zoom switch is pushed, the zoom bar appears on the monitor.
- When the optical zoom factor is at maximum, zooming stops temporarily. When the zoom switch is pushed toward the [T/🔍] side again, the mode changes to the digital zoom mode and zooming continues.

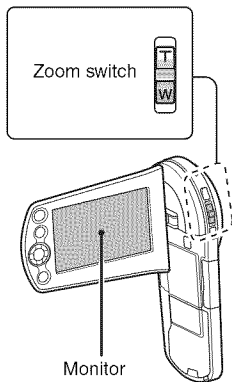

SHOOTING

3 Take the picture.

For video clip recording, see page 31.

For shooting single shots, see page 32.

For shooting sequential shots, see page 45.

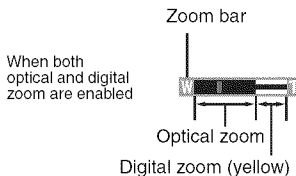

When optical zoom only is enabled



PLAYING BACK VIDEO CLIPS AND STILL IMAGES

1 Set the camera to the playback mode (page 25).

2 Select the image to play back.

- Use the arrow keys to move the orange frame to the file you wish to play back.
- The image information for the framed image is shown at the bottom of the screen.

Orange frame

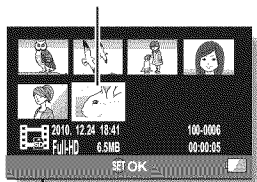

3 Press the SET button.

- The image you selected in step 2 is displayed fullscreen.
- If a video clip was selected, playback begins.

<To return to the screen to select playback files>

Press [▼].

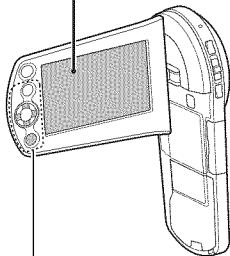

Arrow keys

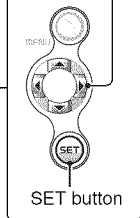

SET button

Video clip playback operation

To do this...		Do this
Normal forward playback		Press the SET button.
Stop playback		During playback, press [▼].
Pause		During playback, press the SET button or press [▲]. During accelerated playback, press [▲].
To play back one image at a time (single-frame step)	Forward playback	After pausing playback, press [▶].
	Reverse playback	After pausing playback, press [◀].
Slow playback	Forward playback	After pausing playback, press and hold [▶].
	Reverse playback	After pausing playback, press and hold [◀].
To accelerate playback	Forward playback	During forward playback, press [▶]. • The playback speed changes each time [▶] is pressed, as follows: Normal playback → 2× → 5× → 10× → 15× Press [◀] to resume normal playback speed.
	Reverse playback	During forward playback, press [◀]. • The playback speed changes each time [◀] is pressed, as follows: 15× ← 10× ← 5× Press [▶] to resume normal playback speed.
Return to normal playback speed		Press the SET button.
Adjusting the volume		Louder: During playback, push the zoom switch toward the [T] side. Softer: During playback, push the zoom switch toward the [W] side.



HINT

If the appears on the playback Screen...

- The  icon appears when playing back a file that was saved in segments (page 45).

How to save one frame from a video clip as a still image

- 1 Play back the video clip. Pause the playback at the point you wish to “snap” a photo.

- 2 Press the [] button.
 - The screen to select the aspect ratio of the still image appears. Select the desired aspect ratio, and press the [] button. Note, however, that if the video clip aspect ratio is 4:3, you cannot select 16:9.

HINT

The file size for a video clip is very large

- Therefore, be aware that if the video clip is uploaded to a computer to be played back, the computer may not be able to play back the video fast enough, making it appear jerky. (The video will always be displayed properly on the camera monitor or a television.)
- Depending on the card, recording may end even before the possible recording time indicated.

Display the video clip playback point

- During video clip playback, press the MENU button for at least 1 second to display a bar showing the current playback point in the video clip.
- Press the MENU button for about 1 second to cancel the bar.

CAUTION

During video clip playback, the sound of a motor is audible...

- During recording, the sound of the optical zoom movement or autofocus movement was recorded. This is not a malfunction.

If no audio is heard...

- The audio is not played back when the video clip is played back in the frame-by-frame, slow-motion, fast playback or reverse playback mode.

CONNECTING TO A TV

By connecting the camera to a TV, you can play back the recorded files on the TV.

CAUTION

Insert and pull out the cable carefully

- When connecting the cables, make sure that the cable plugs are correctly oriented and that they match the shapes of the terminal sockets on the devices. Push the plugs in straight when connecting them. If undue force is used to connect a cable, it may permanently damage the connector pins in the terminal socket.
- Do not use excessive force when connecting and disconnecting cables.

About image output: The image output destination differs depending on the camera status.

Connection cable	Image output destination	Recording mode		Playback mode
		Standby	Recording	
Dedicated AV interface cable	Camera monitor	NTSC: × PAL: ○	○	×
	TV	NTSC: ○ PAL: ×	×	○
HDMI cable	Camera monitor	×	○	×
	TV	○	×	○

○: Images are output ×: Images are not output

HINT

- HDMI, the HDMI logo and High-Definition Multimedia Interface are trademarks or registered trademarks of HDMI Licensing, LLC.



Connecting to a video input terminal

Use the supplied dedicated AV interface cable to connect to a TV.

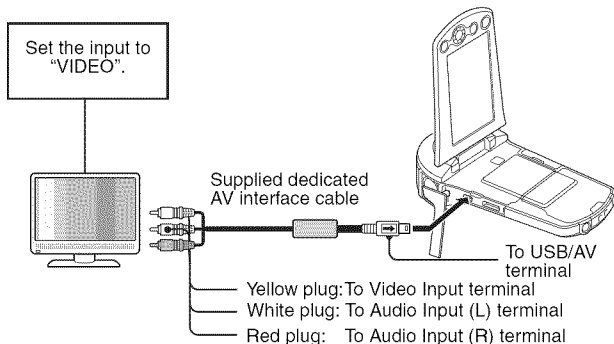

Connecting to the HDMI terminal

Use a separately sold mini-HDMI cable to connect to a TV.

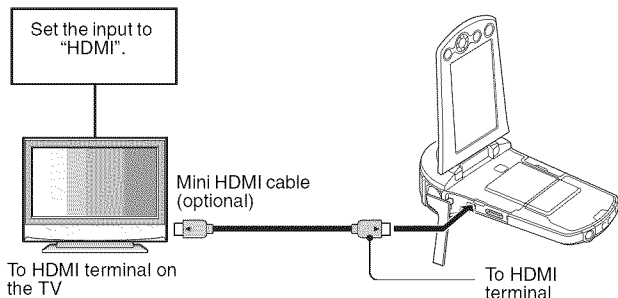

PLAYING BACK ON A TV

- After connecting the camera to the television, switch the TV input to the terminal to which the camera is connected.
- The playback method is the same as when viewing images on the camera's monitor. (Use the TV controls to adjust the volume.)
- The same playback procedure as when playing back with the camera is used to play back audio recordings as well.

CAUTION

Insert and pull out the cable carefully

- When connecting the cables, make sure that the cable plugs are correctly oriented and that they match the shapes of the terminal sockets on the devices. Push the plugs in straight when connecting them. If undue force is used to connect a cable, it may permanently damage the connector pins in the terminal socket.
- Do not use excessive force when connecting and disconnecting cables.

OBTAINING THE INSTRUCTION MANUAL

The Instruction Manual that explains the features in detail can be downloaded from our website.

- "Adobe Reader" is required to view the Instruction Manual. If Adobe Reader is not already installed on your computer, a link to the website from which you can download it can be found on our website.

Contents of the Instruction Manual

Explanations for the functions indicated below can be found in the downloadable Instruction Manual.

Please be sure to obtain and use the Instruction Manual.

HOW TO READ THIS MANUAL

QUICK SEARCH BY OPERATION

CHECKING THE INCLUDED ACCESSORIES

How to use the accessories

ABOUT THE CARD

Media cards that can be used with this camera

What "card" means in this manual

GETTING THE MOST OUT OF YOUR CAMERA

High-quality images with "Full High Definition"

Includes SIMPLE mode for quick-and-easy operation

Image stabilizer for sharp pictures

Capture clear images of the targeted subject

Eye-Fi smart

SYSTEM MAP

■ SETUP

PARTS NAMES

CHARGING THE BATTERY PACK

Charging the battery pack

INSTALLING THE CARD

INSTALLING THE BATTERY PACK

Installing the DC adaptor (sold separately: VAR-A3U/A3EX)

About the temperature alert icon 

TURNING THE CAMERA ON AND OFF

Turning on the camera

Turning off the camera

Turning on the camera when the power save (sleep) mode is active

DATE AND TIME SETTING

SWITCHING BETWEEN THE RECORDING MODE AND PLAYBACK MODE SWITCHING THE OPERATING MODE

- Switching between the SIMPLE and NORMAL modes
- Accessing/exiting the SIMPLE/NORMAL Mode Menu Screen
- Overview of the SIMPLE Mode Setting Screen
- Overview of the NORMAL Mode Setting Screen

■ SIMPLE

SHOOTING

BEFORE TAKING PICTURES

- For best results
- Using the autofocus
- Select the recording size
- Select the focus setting
- Hints for taking pictures

VIDEO CLIP RECORDING

SHOOTING SINGLE SHOTS

- Using the LED light

SHOOT A STILL IMAGE WHILE RECORDING A VIDEO CLIP

MACRO-PHOTOGRAPHY (ZOOM)

PLAYBACK

PLAYING BACK VIDEO CLIPS AND STILL IMAGES

- How to save one frame from a video clip as a still image

SLIDESHOW PLAYBACK

PLAYBACK VOLUME

DELETING FILES

- Delete single/delete all/delete folder
- Delete selected

PLAYBACK MODES

- 21-image display playback
- Selecting the playback folder
- Magnifying (zooming in) the image

■ NORMAL

SHOOTING

RECORDING MENU 1

- Video setting
- Still image setting
- Scene select setting
- Filter setting
- Self-timer setting

RECORDING MENU 2

- Motion compensation (image stabilizer) setting
- Focus range setting

- Focus mode setting
- Light-measuring mode setting
- ISO sensitivity setting

RECORDING MENU 3

- White balance setting
- Exposure setting
- Subject chaser settings
- High sensitivity mode setting
- Digital zoom setting
- Exposure compensation
- Storage folder setting

PLAYBACK

PLAYBACK MENU 1

- Slideshow settings
- File protect setting
- Resize
- Rotate

PLAYBACK MENU 2

- Correcting the image
- Editing video clips
- Printing instructions

FILE INFO DISPLAY

■ OPTION SETTINGS

DISPLAY THE OPTION SETTING MENU

INTRODUCTION TO THE OPTION SETTING MENU

- Shortcut setting
- TV output setting
- File No. continued setting
- Formatting (initializing)

CHECKING THE REMAINING CARD MEMORY

- Checking the remaining number of images and video recording time
- For audio recordings

CHECKING THE REMAINING BATTERY PACK CHARGE

■ OTHER DEVICES AND CONNECTIONS

CONNECTING TO A TV

CONNECTING TO A TV

- Connecting to a video input terminal
- Connecting to the HDMI terminal

PLAYING BACK ON A TV

CONNECTING TO A PRINTER

PRINTING

■ APPENDICES

COMMONLY ASKED QUESTIONS

TROUBLESHOOTING

Camera

Notes regarding the Scene Select feature and filters

SPECIFICATIONS

Camera

Camera connectors

Battery life

Possible No. of Images/Possible Shooting Time/Possible Recording Time

Concerning the multi-indicator

Supplied battery pack charger

Supplied Li-ion battery pack

Others

Before capturing those important shots, be sure to first take a test shot to confirm that your camera is set up and ready to go

HINTS FOR TAKING PICTURES

How to obtain the Instruction Manual

The Instruction Manual that explains the camera functions in detail can be obtained from the SANYO website.

-
- 1** Insert the supplied Xacti Software CD in your computer's CD drive.

 - 2** On the installation screen, click [Go to Xacti CS1 Web Support Page].

 - 3** Follow the instructions on the screen to download the Instruction Manual.
 - "Adobe Reader" is required to view the Instruction Manual.
Adobe Reader can be found in the Xacti Software CD.

ABOUT THE EYE-FI TRANSFER FEATURE

By inserting a commercially sold Eye-Fi card (SD card with wireless LAN) in your camera, you can easily upload photos to your computer, a sharing site, etc. automatically via a Wi-Fi network. Also, you can transfer video files if your Eye-Fi card has a video upload function. The Eye-Fi card settings can be performed using the Eye-Fi Manager, but in addition, the settings below can be performed with this camera.

- Eye-Fi automatic transfer ON/OFF
- Automatic halt of Eye-Fi operation when battery is low
- AC adaptor connection restrictions (may or may not be supported, depending on the camera)
- SSID setup/delete

HINT

- The Instruction Manual for the Eye-Fi transfer feature can be obtained from the Sanyo website (page 49).
 - * "Adobe Reader" is required to view the Instruction Manual. Adobe Reader can be found in the Xacti Software CD.



COMMONLY ASKED QUESTIONS

If you have a question about the camera operation, you might find the answer in this compilation of commonly asked questions.

	Question	Answer	Action
Power	Why doesn't the power turn on?	Due to cold temperatures, the battery pack temporarily lost its power.	Place the camera in your pocket to warm it up before using it.
	Why is the battery pack consumed so quickly even after it was fully recharged?	The ambient temperature is very low.	Keep the battery pack in an environment of 10 to 40 °C (50 to 104 °F).
		The battery pack life has expired.	If a battery becomes depleted quickly even after it was sufficiently charged, it should be assumed that the battery has reached the end of its service life. Please replace it with a new battery.
	Why doesn't recharging end?	The battery pack life has expired.	Replace with a new battery pack. If this is not effective, consult your dealer.
Why does the  icon appear?	The remaining battery pack power is low.	Use the AC adaptor, and DC adaptor (optional) or replace the battery pack with a fully charged one.	
Shooting	Why does the multi-indicator flash red?	A recorded file is being saved on the card.	Not a malfunction. Wait until the multi-indicator turns off.

	Question	Answer	Action
Shooting	Are the settings retained even after the camera is turned off?	—	All settings except the self-timer and the exposure compensation are retained even after the camera is turned off.
	Which resolution setting should I use?	—	Select the resolution setting according to the intended use. 8M , 6M , 3M-H , 3M-S , 3M , 6M , 3M : Appropriate for printing letter-size or larger, and for printing a close-up of part of a photo (trimming). 2M , 2M : For printing standard photo (photo service) sizes. 0.9M , 0.3M : For photos displayed on a web page, or sent as e-mail attachments.

	Question	Answer	Action
Shooting	What is the difference between the digital zoom and the optical zoom?	—	Because shooting with the optical zoom uses the optics of a physical lens, you can shoot without losing minute details in the image. The digital zoom, on the other hand, works by magnifying a portion of the image that hits the image sensor and may produce a coarser image.
	How can I get the distant view into focus?	—	Set the scene select function to the landscape  mode when photographing. Or, set the focus range setting to manual focus [MF] , and set the distance to ∞.

	Question	Answer	Action
Monitor	When used in cold weather, why does the image seem to leave traces as it moves?	Condition due to the monitor characteristics.	Not a malfunction. Spots that appear in the monitor only appear in the monitor and will not be recorded with the images.
	Why does the displayed image contain some red, blue and green dots, or why are black spots visible?		
Viewing images	Why is the image too bright?	The subject was too bright.	When capturing an image, devise a way to compensate for a bright subject, for example, by changing the shooting angle.
	Why is the image out of focus?	The focus is not locked properly.	Hold the camera correctly and slowly press the [] button halfway to lock the focus. Then press the [] button all the way to capture the image.

	Question	Answer	Action
Viewing images	Why is there no image (□ is shown)?	This may happen when trying to play back images stored on a card from a different digital camera.	Play back images that were recorded on a card using this camera.
	Why is the playback image distorted?	If the subject moves or the camera is moved during recording, a distorted image may sometimes occur.	Not a malfunction. This is a characteristic of the CMOS sensor.

	Question	Answer	Action
Viewing images	Why isn't the magnified image clear?	Due to the characteristics of the camera, magnified images appear less clear.	Not a malfunction.
	Why isn't the captured image clear?	The image was captured using the digital zoom.	Not a malfunction.
	Can I play back image and sound files that I edited using my computer?	—	We cannot guarantee the accurate playback of files that have been edited using a computer.
	Why is there a motor-like sound during video clip playback?	The sound of the camera's mechanical action was recorded.	Not a malfunction.
Connecting to a TV	Why is there no sound?	The volume on the TV is set to the minimum.	Adjust the volume on the TV.
Printing	Why does a message appear during PictBridge printing?	There is a problem with the printer.	Please refer to the instruction manual for your printer.

	Question	Answer	Action
Misc.	The "Cannot edit video clips with unlike settings" message appears.	You have attempted to join video clips having different resolutions or frame rates.	Select video clips that have the same resolution or frame rate.
	Why is a noise heard from a nearby TV or radio during battery recharging?	Electromagnetic waves are emitted from the charger.	Move the AC adaptor further away from the TV or radio when recharging the battery pack.
	Why does the "Insufficient card memory" or "Insufficient internal memory" message appear?	There is no more available memory on the card or in the camera's internal memory.	Delete unnecessary files, or use a card that has more memory available.
	Why does the "Card is protected" message appear?	The lock switch on the card is in the locked (protect) position.	Move the lock switch to the unlocked position.
	Why can't the camera be operated?	A temporary internal circuitry problem may be the cause.	Remove the AC adaptor and the battery pack from the camera, wait a few minutes, then reinstall the battery pack and try again.
	A problem such as inability to record or play back occurs.	The card contains files that were saved using a device other than this camera.	After saving your files to a different medium, format the card.

	Question	Answer	Action
Misc.	Can I use my camera abroad?	—	When the camera is connected to a TV, you can switch the camera's video output to NTSC or PAL. If you have questions about accessories etc., please consult with a dealer near you for advice.
	Why does the "System error" message appear?	A problem has occurred within the camera or card.	<p>Check the following items:</p> <ol style="list-style-type: none"> ① Remove the card and then install it again. ② Remove the battery pack and then install it again. ③ Install a different card. <p>If "System error" still appears after performing the above steps, then take the camera to the dealer for service.</p>



SPECIFICATIONS

Camera

Recorded image file format	<p>Still images: JPEG format (DCF, DPOF, Exif 2.2 compliant) Note: Designed mainly by the Japan Electronics and Information Technology Industries Association (JEITA), DCF (Design rule for Camera File system) is standard for digital still camera image files to provide interoperability between digital photography devices for the images stored on removable memory cards. However, it is not guaranteed that all devices will support the DCF standard.</p> <p>Video clips: Conforms to ISO-standard MPEG-4 AVC/H.264*</p> <p>Audio: MPEG-4 audio (AAC compression) 48 kHz sampling rate, 16-bit stereo format</p>
Data storage media	Internal memory: Approx. 50 MB SD Memory Card SDHC Memory Card (up to 32 GB) SDXC Memory Card (up to 64 GB)
Image sensor/ camera effective number of pixels	1/5-inch (0.5 cm) CMOS sensor Still images: Approx. 3.3 million pixels Videos (HD mode): Approx. 2.8 million pixels Videos (SD mode): Approx. 3.3 million pixels

* Video clip files recorded with models VPC-CA65 and VPC-CG65 are in the same H.264 format as this model. However, such files cannot be played back, since they are not compatible due to differences such as the data compression method.

Still image shooting mode (recording resolution)	<p>8M: 3264 × 2448 pixels (approx. 8 million pixels)</p> <p>6M: 3328 × 1872 pixels (approx. 6 million pixels, 16:9 aspect ratio)</p> <p>3M-H: 2048 × 1536 pixels (approx. 3 million pixels, low compression)</p> <p>3M-S: 2048 × 1536 pixels (approx. 3 million pixels, normal compression)</p> <p>3M: 2288 × 1288 pixels (approx. 3 million pixels, 16:9 aspect ratio)</p> <p>2M: 1920 × 1080 pixels (approx. 2 million pixels, 16:9 aspect ratio)</p> <p>2M: 1600 × 1200 pixels (approx. 2 million pixels)</p> <p>0.9M: 1280 × 720 pixels (approx. 900,000 pixels, 16:9 aspect ratio)</p> <p>0.3M: 640 × 480 pixels (approx. 300,000 pixels)</p> <p>80FPS: 3264 × 2448 pixels (approx. 8 million pixels, sequential shots)</p> <p>30FPS: 2048 × 1536 pixels (approx. 3 million pixels, sequential shots)</p>
Video clip recording mode (recording resolution)	<p>Full-HD: 1920 × 1080 pixels, 60 fields/s (60i)</p> <p>Full-SHD: 1920 × 1080 pixels, 30 fps (30p)</p> <p>HD-HR: 1280 × 720 pixels, 60 fps (60p)</p> <p>HD-SHD: 1280 × 720 pixels, 30 fps (30p)</p> <p>☆: 960 × 540 pixels, 30 fps (30p)</p> <p>TV-SHD: 640 × 480 pixels, 30 fps (30p)</p> <ul style="list-style-type: none"> The 60 fps frame rate of this camera is 59.94 fps, and the 30 fps frame rate is 29.97 fps.
White balance	Full-auto TTL; manual setting available
Lens	<p>Focal length: $f = 3.2$ mm to 28.8 mm, Optical 9× zoom</p> <p>Open: $F = 2.8$ (wide) to 3.0 (tele)</p> <p>9 groups, 12 elements (including three with six aspheric surfaces)</p> <p>Galvanometer iris</p> <p>Internal ND filter</p> <p>35 mm film camera conversion</p> <p>Still image shooting: 38 mm to 342 mm (9× optical zoom)</p> <p>Video clip recording: 38 mm to 380 mm (10× advanced zoom)</p>



Exposure control type	Programmable AE/Shutter speed priority AE/ Aperture priority AE/Manual exposure control Exposure compensation available (0 ±1.8 EV in 0.3 EV steps)
Light-measuring mode	Multi-section measuring, center-weighted measuring, spot measuring
Range	Normal mode: 50 cm (19.69 in.) to infinity Super macro mode: 1 cm (0.39 in.) to 1 m (3.28 ft.) (wide end only)
Digital zoom	For shooting: 1× to approx. 10× For playback: 1× to 51× (varies with resolution)
Shutter speed	Still image shooting mode: 1/2 to 1/1,000 sec. (Maximum approx. 1 sec. when scene select function set to lamp ) Sequential shots mode: 1/15 to 1/1,000 sec. Video clip recording mode: 1/30 to 1/10,000 sec. (1/15 sec. max.: when scene select function is set to the lamp  or high sensitivity mode)
Sensitivity	Still image shooting (standard output sensitivity*)/ video clip recording mode: Auto Still image shooting LED light off: ISO 50 to 400 LED light on: ISO 50 to 800 Video clip recording: ISO 50 to 800 ISO 50, 100, 200, 400, 800, 1600 (Switchable from the Recording Menu) * Sensitivity measured in compliance with the ISO standard (ISO 12232:2006). * Maximum ISO sensitivity up to 1600 equivalent when Scene Select function is set to  .
Minimum subject illumination	Approx. 15 lux (1/30 sec in the scene select AUTO mode) Approx. 4 lux (1/15 sec in the lamp or HIGH SENSITIVITY mode)
Image stabilizer	Video: Electronic Still image: Multi-calculation electronic

Monitor	2.7" (6.9 cm) low-temperature polysilicon TFT color wide liquid crystal (transmissive), approx. 230,000 pixels	
Built-in flash	No	
LED light working range	Approx. 10 cm (3.94 in.) to 1 m (3.28 ft.) Super macro mode (wide side only)	
LED light modes	ON, OFF	
Focus	TTL-type AF (still image shooting mode: 9-point range finder/spot focus; video clip recording mode: Continuous focus), manual focus	
Self-timer	Approx. 2-second delay, 10-second delay	
Ambient environment	Temperature	0 to 40 °C (32 to 104 °F) (operation) -20 to 60 °C (-4 to 140 °F) (storage)
	Humidity	30 to 90% (operating, no condensation) 10 to 90% (storage, no condensation)
Power supply	Battery pack (supplied)	Li-ion battery pack (DB-L80) ×1
	AC adaptor (optional)	VAR-G9 For use with DC adaptor (VAR-A3: sold separately)
Power consumption	3.5 W (When using the Li-ion battery during recording)	
Dimensions (excluding protrusions)	62.5 (W) × 26.8 (D) × 123.5 (H) mm 2.46 (W) × 1.06 (D) × 4.86 (H) in. (Maximum dimensions) Volumetric capacity: Approx. 126 cc	
Weight	Approx. 142 g (5.0 oz.) (camera only [without battery pack and card]) Approx. 159 g (5.6 oz.) (including battery pack and card)	

Camera connectors



















USB/AV (communication/audio and video output) terminal	Dedicated regrouped jack	
	Audio output	Stereo
	Video output	Composite video, NTSC color TV system/PAL TV system (switchable from the Option Setting Menu)
	USB	USB 2.0 High Speed PC camera: USB video class
HDMI terminal		Video output Total number of scan lines (effective number of scan lines): 750p (720p)/1125i (1080i)/525p (480p) Audio output: L-PCM 48 kHz sampling

Battery life

Shooting	Still image shooting mode	Approx. 200 images: CIPA standard (when a SanDisk 2 GB SD Memory Card is used)
	Video clip recording mode	Approx. 60 minutes: Recorded in  mode (When LED light is OFF) Approx. 70 minutes: Recorded in  mode (When LED light is OFF)
Playback		Approx. 210 minutes: Monitor on, continuous playback

- Until battery pack runs out when using a fully charged battery pack at a 25 °C (77 °F) ambient temperature.
- The operation time may vary depending on the conditions of the battery pack and the conditions of use. Especially when used at temperatures below 10 °C (50 °F), the battery pack operation time is significantly reduced.

Possible No. of Images/Possible Shooting Time/ Possible Recording Time

Shooting/ recording mode	Resolution setting	Internal Memory	SD Memory Card	
			8 GB	16 GB
Still image mode		19 images	2,960 images	5,940 images
		24 images	3,770 images	7,560 images
		32 images	4,980 images	9,980 images
		48 images	7,320 images	14,600 images
		51 images	7,780 images	15,600 images
		71 images	10,800 images	21,700 images
		76 images	11,300 images	22,700 images
		142 images	20,700 images	41,600 images
		327 images	49,800 images	99,800 images
			19 images	2,960 images
		48 images	7,320 images	14,600 images
Video clip mode		22 sec.	1 hr. 1 min.	2 hr. 4 min.
		29 sec.	1 hr. 21 min.	2 hr. 43 min.
		29 sec.	1 hr. 21 min.	2 hr. 43 min.
		38 sec.	1 hr. 46 min.	3 hr. 33 min.
		15 sec.	42 min.	1 hr. 24 min.
		1 min. 34 sec.	4 hr. 19 min.	8 hr. 39 min.
Audio recording mode		26 min. 10 sec.	67 hr.	134 hr.

- If the continuous recording time of a voice memo exceeds about 13 hours, the recorded file is saved once, and then recording continues in a new file. In the video clip recording mode, when the size of the file being recorded exceeds 4 GB, the recorded file is saved once, and then recording continues in a new file. (These 4 GB segments are automatically created. The recording session continues until you stop recording, but voice memo recording is temporarily interrupted while the file is being saved.)
- The above values apply when an SD Memory Card by SanDisk is used.
- Even with cards of the same capacity, the amount of data that can actually be stored may differ depending on the card brand, etc.
- The continuous shooting time for each video clip will differ depending, for example, on the card capacity, environmental conditions (temperature and shooting conditions, etc.).

Concerning the multi-indicator

The camera's multi-indicator will light, flash, or be off, depending on the different camera operations.

Color	Multi-indicator status	Camera status	
Green	Lit	Connected to a computer or printer	
	Flashing	Power save mode active	
Orange	Lit	Connected to a TV	
Red	Flashing	Slow	Rise in internal temperature
		Fast	During self-timer photography
		Very fast	Accessing card

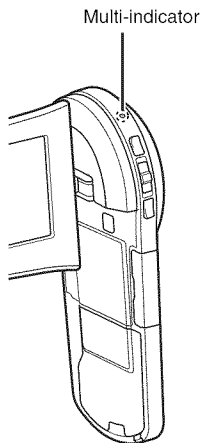

Supplied battery pack charger

Part No.		VAR-L80
Power source		AC 100 to 240 V, 50 to 60 Hz, 5 W
Rated output		DC 4.2 V, 550 mA
Compatible batteries		Supplied or separately sold Lithium-ion battery pack (DB-L80)
Ambient environment	Temperature	0 to 40 °C (32 to 104 °F) (when charging) -20 to 60 °C (-4 to 140 °F) (storage)
	Humidity	20 to 80% (no condensation)
Dimensions		84.0 (W) × 50.5 (D) × 22.5 (H) mm 3.31" (W) × 1.99" (D) × 0.89" (H)
Weight (without power cord)		Approx. 49 g (1.7 oz.)

- When using the supplied battery pack charger abroad, the power cord may need to be replaced in accordance with local requirements. Please contact your local dealer for details.

Supplied Li-ion battery pack

Model number		DB-L80
Voltage		3.7 V
Capacity		700 mAh
Ambient environment	Temperature	0 to 40 °C (32 to 104 °F) (during use) -10 to 30 °C (14 to 86 °F) (storage)
	Humidity	10 to 90% (no condensation)
Dimensions		39.2 (W) × 31.4 (D) × 5.9 (H) mm 1.54 (W) × 1.24 (D) × 0.23 (H) in.
Weight		Approx. 15 g (0.5 oz.)

Others

Mac OS is a trademark of Apple Inc., registered in the U.S. and other countries.

Microsoft and Windows are registered trademarks of Microsoft Corporation in the USA and other countries.

Intel and Pentium are registered trademarks of Intel Corporation (USA). In this manual, the Microsoft® Windows® 2000 operating system, Microsoft® Windows® XP operating system, Microsoft® Windows® Vista operating system, and Microsoft® Windows® 7 operating system are collectively referred to as "Windows".

Software Red Eye by FotoNation™ 2003-2005 is a trademark of FotoNation® Inc.

Red Eye software© 2003-2005 FotoNation In Camera Red Eye - covered by U.S. Patent No. 6,407,777. Other patents Pending.



SDXC logo is a trademark.



HDMI, the HDMI logo and High-Definition Multimedia Interface are trademarks or registered trademarks of HDMI Licensing, LLC.



Eye-Fi is a registered trademark of Eye-Fi, Inc.

All other company and product names are registered trademarks or trademarks of their respective owners.

CAUTION

- It is forbidden to copy this manual, whole or in part, without prior written permission.
- All images and illustrations given in this manual are for explanation purposes and may differ slightly from that of the actual product. Also, actual specifications are subject to change without prior notice and therefore may differ from the contents of this manual.

Before capturing those important shots, be sure to first take a test shot to confirm that your camera is set up and ready to go

- Sanyo Electric shall not be held responsible for any problems resulting from the use of this camera.
- Sanyo Electric declines all responsibility for damages due to improper use of the camera, failure to adhere to the instructions given in this manual, or repairs or changes done by those other than a technician authorized by the manufacturer.
- Sanyo Electric shall not be held responsible for any damage caused by optional devices or consumable items used with the camera other than those supplied with the camera or those specified by Sanyo Electric.
- Sanyo Electric shall not be held responsible for any losses or loss of revenue resulting from the loss of data caused by the malfunction, or the repairing of a malfunction, of the camera.
- The images captured with this camera will differ in quality from pictures taken with a standard film camera.

SANYO

SANYO Electric Co., Ltd.