

SEARS

**OWNER'S
MANUAL**

**MODEL NO.
917.299881**

Caution:
Read and follow
all Safety Rules
and Instructions
Before Operating
This Equipment

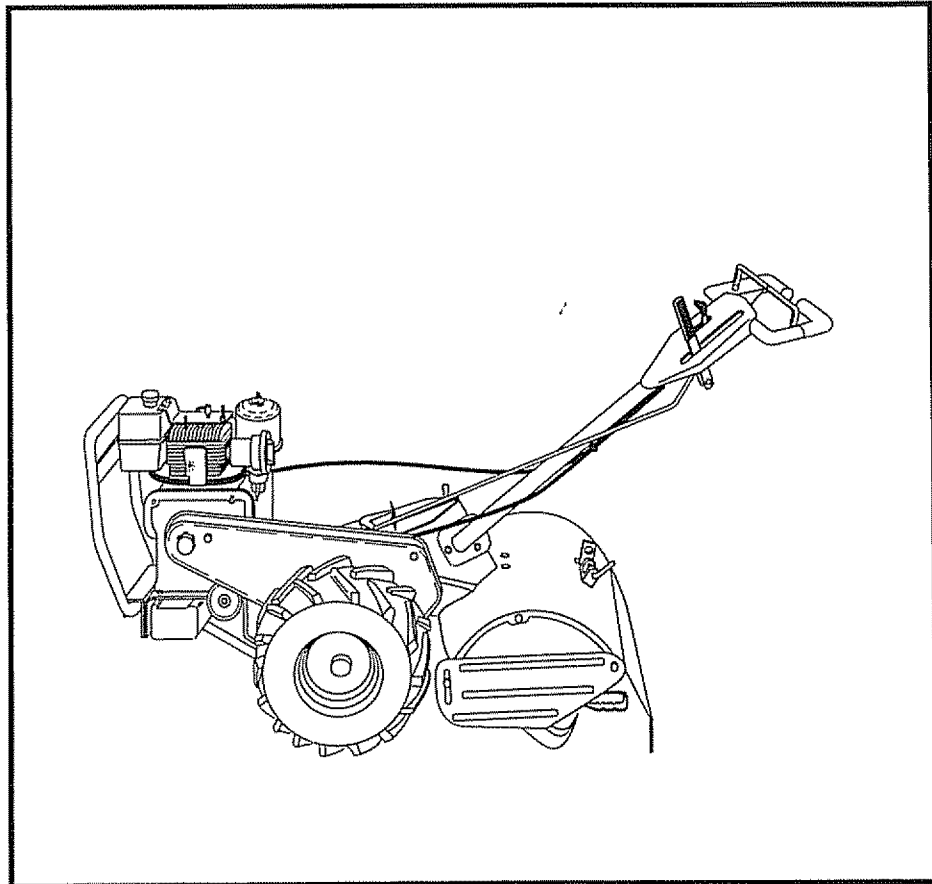

CRAFTSMAN[®]

8.0 HP

21 INCH TINE WIDTH

REAR TINE TILLER WITH

COUNTER ROTATING TINES

- **Assembly**
- **Operation**
- **Customer Responsibilities**
- **Service and Adjustments**
- **Repair Parts**

Sears, Roebuck and Co., Hoffman Estates, IL 60179 U.S.A.



SAFETY RULES



Safe Operation Practices for Walk-Behind Powered Rotary Tillers

TRAINING

- Read the Owner's Manual carefully. Be thoroughly familiar with the controls and the proper use of the equipment. Know how to stop the unit and disengage the controls quickly.
- Never allow children to operate the equipment. Never allow adults to operate the equipment without proper instruction.
- Keep the area of operation clear of all persons, particularly small children, and pets.

PREPARATION

- Thoroughly inspect the area where the equipment is to be used and remove all foreign objects.
- Disengage all clutches and shift into neutral before starting the engine (motor).
- Do not operate the equipment without wearing adequate outer garments. Wear footwear that will improve footing on slippery surfaces.
- Handle fuel with care; it is highly flammable.
 - Use an approved fuel container.
 - Never add fuel to a running engine or hot engine.
 - Fill fuel tank outdoors with extreme care. Never fill fuel tank indoors.
 - Replace gasoline cap securely and clean up spilled fuel before restarting.
- Use extension cords and receptacles as specified by the manufacturer for all units with electric drive motors or electric starting motors.
- Never attempt to make any adjustments while the engine (motor) is running (except where specifically recommended by manufacturer).

OPERATION

- Do not put hands or feet near or under rotating parts.
- Exercise extreme caution when operating on or crossing gravel drives, walks, or roads. Stay alert for hidden hazards or traffic. Do not carry passengers.
- After striking a foreign object, stop the engine (motor), remove the wire from the spark plug, thoroughly inspect the tiller for any damage, and repair the damage before restarting and operating the tiller.
- Exercise caution to avoid slipping or falling.

- If the unit should start to vibrate abnormally, stop the engine (motor) and check immediately for the cause. Vibration is generally a warning of trouble.
- Stop the engine (motor) when leaving the operating position.
- Take all possible precautions when leaving the machine unattended. Disengage the tines, shift into neutral, and stop the engine.
- Before cleaning, repairing, or inspecting, shut off the engine and make certain all moving parts have stopped. Disconnect the spark plug wire, and keep the wire away from the plug to prevent accidental starting. Disconnect the cord on electric motors.
- Do not run the engine indoors; exhaust fumes are dangerous.
- Never operate the tiller without proper guards, plates, or other safety protective devices in place.
- Keep children and pets away.
- Do not overload the machine capacity by attempting to till too deep at too fast a rate.
- Never operate the machine at high speeds on slippery surfaces. Look behind and use care when backing.
- Never allow bystanders near the unit.
- Use only attachments and accessories approved by the manufacturer of the tiller (such as wheel weights, counterweights, cabs, and the like).
- Never operate the tiller without good visibility or light.
- Be careful when tilling in hard ground. The tines may catch in the ground and propel the tiller forward. If this occurs, let go of the handlebars and do not restrain the machine.

MAINTENANCE AND STORAGE

- Keep machine, attachments, and accessories in safe working condition.
- Check shear pins, engine mounting bolts, and other bolts at frequent intervals for proper tightness to be sure the equipment is in safe working condition.
- Never store the machine with fuel in the fuel tank inside a building where ignition sources are present, such as hot water and space heaters, clothes dryers, and the like. Allow the engine to cool before storing in any enclosure.
- Always refer to the operator's guide instructions for important details if the tiller is to be stored for an extended period.

- IMPORTANT -

CAUTIONS, IMPORTANTS, AND NOTES ARE A MEANS OF ATTRACTING ATTENTION TO IMPORTANT OR CRITICAL INFORMATION IN THIS MANUAL.



CAUTION: Look for this symbol to point out important safety precautions. It means —Attention! Become Alert! Your safety is involved.

IMPORTANT: USED TO ALERT YOU THAT THERE IS A POSSIBILITY OF DAMAGING THIS EQUIPMENT.

NOTE: Gives essential information that will aid you to better understand, incorporate, or execute a particular set of instructions.

CONGRATULATIONS on your purchase of a Sears Tiller. It has been designed, engineered and manufactured to give you the best possible dependability and performance.

Should you experience any problems you cannot easily remedy, please contact your nearest authorized Sears Service Center/Department. They have competent, well-trained technicians and the proper tools to service or repair this tiller.

Please read and retain this manual. The instructions will enable you to assemble and maintain your tiller properly. Always observe the "SAFETY RULES".

PRODUCT SPECIFICATIONS

HORSEPOWER:	8.0 HP
DISPLACEMENT:	16.79 cu. in.
GASOLINE CAPACITY:	4 Quarts Unleaded Regular
OIL(API-SF/SG) : (CAPACITY: 44 oz.)	SAE 30 (Above 32°F) SAE 5W-30 (Below 32°F)
SPARK PLUG : (GAP: .030")	Champion RJ19LM (STD361458)

MODEL
NUMBER **917.299881**

SERIAL
NUMBER _____

DATE OF
PURCHASE _____

THE MODEL AND SERIAL NUMBERS WILL BE FOUND ON THE MODEL PLATE ATTACHED TO THE TOP OF THE TRANSMISSION.

YOU SHOULD RECORD BOTH SERIAL NUMBER AND DATE OF PURCHASE AND KEEP IN A SAFE PLACE FOR FUTURE REFERENCE.

MAINTENANCE AGREEMENT

A Sears Maintenance Agreement is available on this tiller. Contact your nearest Sears store for details.

CUSTOMER RESPONSIBILITIES

- Read and observe the safety rules.
- Follow a regular schedule in maintaining, caring for and using your tiller.
- Follow the instructions under the "Customer Responsibilities" and "Storage" sections of this manual.

IMPORTANT: THIS TILLER IS EQUIPPED WITH AN INTERNAL COMBUSTION ENGINE AND SHOULD NOT BE USED ON OR NEAR ANY UNIMPROVED FOREST-COVERED, BRUSH-COVERED OR GRASS COVERED LAND UNLESS THE ENGINE'S EXHAUST SYSTEM IS EQUIPPED WITH A SPARK ARRESTER MEETING APPLICABLE LOCAL OR STATE LAWS (IF ANY). IF A SPARK ARRESTER IS USED, IT SHOULD BE MAINTAINED IN EFFECTIVE WORKING ORDER BY THE OPERATOR.

IN THE STATE OF CALIFORNIA THE ABOVE IS REQUIRED BY LAW (SECTION 4442 OF THE CALIFORNIA PUBLIC RESOURCES CODE). OTHER STATES MAY HAVE SIMILAR LAWS. FEDERAL LAWS APPLY ON FEDERAL LANDS. SEE YOUR SEARS AUTHORIZED SERVICE CENTER/DEPARTMENT FOR SPARK ARRESTER. REFER TO THE REPAIR PARTS SECTION OF THIS MANUAL FOR PART NUMBER.

LIMITED TWO YEAR WARRANTY ON CRAFTSMAN TILLER

For two (2) years from date of purchase, when this Craftsman Tiller is maintained, lubricated, and tuned up according to the operating and maintenance instructions in the owner's manual, Sears will repair free of charge any defect in material or workmanship.

This Warranty does not cover:

- Expendable items which become worn during normal use, such as tines, spark plugs, air cleaners and belts.
- Repairs necessary because of operator abuse or negligence, including bent crankshafts and the failure to maintain the equipment according to the instructions contained in the owner's manual.
- If this Craftsman Tiller is used for commercial or rental purposes, this Warranty applies for only thirty (30) days from the date of purchase.

WARRANTY SERVICE IS AVAILABLE BY RETURNING THE CRAFTSMAN TILLER TO THE NEAREST SEARS SERVICE CENTER/DEPARTMENT IN THE UNITED STATES. THIS WARRANTY APPLIES ONLY WHILE THIS PRODUCT IS IN USE IN THE UNITED STATES.

This Warranty gives you specific legal rights, and you may also have other rights which vary from state to state.

SEARS, ROEBUCK AND CO., D/817 WA, HOFFMAN ESTATES, ILLINOIS 60179

TABLE OF CONTENTS

SAFETY RULES 2 CUSTOMER RESPONSIBILITIES 3,14-16 PRODUCT SPECIFICATIONS 3 WARRANTY3 ACCESSORIES5 ASSEMBLY 6-8 OPERATION 9-13	MAINTENANCE SCHEDULE 14 SERVICE & ADJUSTMENTS 16-19 STORAGE20 TROUBLESHOOTING21 REPAIR PARTS-TILLER 22-28 REPAIR PARTS-ENGINE 29-32 SERVICE/PARTS ORDERING BACK COVER
---	---

INDEX

<p style="text-align: center;">A</p> Accessories 5 Adjustments: Carburetor 19 Depth Stake 10 Handle Height 16 Side Shields 11 Throttle 19 Tines 18 V-Belt (Ground Drive) 17 Wheels 13 Air Cleaner 15	<p style="text-align: center;">B</p> Belt: Belt Guard 17 Repair Parts 23 V-Belt (Ground Drive) 17	<p style="text-align: center;">C</p> Cooling System 15 Controls: Choke 9 Throttle 9 Drive (Tines) 9 Cultivating 13 Customer Responsibilities: Air Cleaner 15 Cooling System 15 Finish 16 Maintenance Schedule 14 Muffler 16 Oil Change 15 Spark Plug 16 Tines 18 Transmission 16 V-Belt (Ground Drive) 17
<p style="text-align: center;">D</p> Depth Stake: Adjustment 10 Repair Parts 26	<p style="text-align: center;">E</p> Engine: Air Cleaner 15 Cooling System 15 Fuel Type 11	<p style="text-align: center;">F</p> Engine (cont'd) Lubrication 15 Oil Level 11 Oil Type 11,15 Spark Plug 16 Starting 12 Stopping 10 Storage 20 Winter Operation 15
<p style="text-align: center;">G</p>	<p style="text-align: center;">H</p> Handle: Height Adjustment 16 Repair Parts 22	<p style="text-align: center;">I</p>
<p style="text-align: center;">J</p>	<p style="text-align: center;">K</p>	<p style="text-align: center;">L</p> Lubrication: Lubrication Chart 14 Engine 15
<p style="text-align: center;">M</p>	<p style="text-align: center;">N</p>	<p style="text-align: center;">O</p> Oil: Level 11 Type 11,15
<p style="text-align: center;">P</p>	<p style="text-align: center;">Q</p>	<p style="text-align: center;">R</p> Operation: Cultivating 13 Fill Fuel Tank 11 Starting Engine 12 Stopping Tines & Engine 10 Tilling 10 Tilling Hints 12 Tine Operation 10 Transporting Tiller 11 Winter Operation 15
<p style="text-align: center;">S</p>	<p style="text-align: center;">T</p>	<p style="text-align: center;">U</p>
<p style="text-align: center;">V</p>	<p style="text-align: center;">W</p>	<p style="text-align: center;">X</p>
<p style="text-align: center;">Y</p>	<p style="text-align: center;">Z</p>	<p style="text-align: center;">AA</p>
<p style="text-align: center;">AB</p>	<p style="text-align: center;">AC</p>	<p style="text-align: center;">AD</p>
<p style="text-align: center;">AE</p>	<p style="text-align: center;">AF</p>	<p style="text-align: center;">AG</p>
<p style="text-align: center;">AH</p>	<p style="text-align: center;">AI</p>	<p style="text-align: center;">AJ</p>
<p style="text-align: center;">AK</p>	<p style="text-align: center;">AL</p>	<p style="text-align: center;">AM</p>
<p style="text-align: center;">AN</p>	<p style="text-align: center;">AO</p>	<p style="text-align: center;">AP</p>
<p style="text-align: center;">AQ</p>	<p style="text-align: center;">AR</p>	<p style="text-align: center;">AS</p>
<p style="text-align: center;">AT</p>	<p style="text-align: center;">AV</p>	<p style="text-align: center;">AW</p>
<p style="text-align: center;">AX</p>	<p style="text-align: center;">AY</p>	<p style="text-align: center;">AZ</p>
<p style="text-align: center;">BA</p>	<p style="text-align: center;">BB</p>	<p style="text-align: center;">BC</p>
<p style="text-align: center;">BD</p>	<p style="text-align: center;">BE</p>	<p style="text-align: center;">BF</p>
<p style="text-align: center;">BG</p>	<p style="text-align: center;">BH</p>	<p style="text-align: center;">BI</p>
<p style="text-align: center;">BJ</p>	<p style="text-align: center;">BK</p>	<p style="text-align: center;">BL</p>
<p style="text-align: center;">BM</p>	<p style="text-align: center;">BN</p>	<p style="text-align: center;">BO</p>
<p style="text-align: center;">BP</p>	<p style="text-align: center;">BQ</p>	<p style="text-align: center;">BR</p>
<p style="text-align: center;">BS</p>	<p style="text-align: center;">BT</p>	<p style="text-align: center;">BU</p>
<p style="text-align: center;">BV</p>	<p style="text-align: center;">BW</p>	<p style="text-align: center;">BX</p>
<p style="text-align: center;">BY</p>	<p style="text-align: center;">BZ</p>	<p style="text-align: center;">CA</p>
<p style="text-align: center;">CB</p>	<p style="text-align: center;">CC</p>	<p style="text-align: center;">CD</p>
<p style="text-align: center;">CE</p>	<p style="text-align: center;">CF</p>	<p style="text-align: center;">CG</p>
<p style="text-align: center;">CH</p>	<p style="text-align: center;">CI</p>	<p style="text-align: center;">CJ</p>
<p style="text-align: center;">CK</p>	<p style="text-align: center;">CL</p>	<p style="text-align: center;">CM</p>
<p style="text-align: center;">CN</p>	<p style="text-align: center;">CO</p>	<p style="text-align: center;">CP</p>
<p style="text-align: center;">CQ</p>	<p style="text-align: center;">CR</p>	<p style="text-align: center;">CS</p>
<p style="text-align: center;">CT</p>	<p style="text-align: center;">CV</p>	<p style="text-align: center;">CW</p>
<p style="text-align: center;">CX</p>	<p style="text-align: center;">CV</p>	<p style="text-align: center;">CX</p>
<p style="text-align: center;">CY</p>	<p style="text-align: center;">CA</p>	<p style="text-align: center;">CY</p>
<p style="text-align: center;">CA</p>	<p style="text-align: center;">CB</p>	<p style="text-align: center;">CA</p>
<p style="text-align: center;">CB</p>	<p style="text-align: center;">CC</p>	<p style="text-align: center;">CB</p>
<p style="text-align: center;">CC</p>	<p style="text-align: center;">CD</p>	<p style="text-align: center;">CC</p>
<p style="text-align: center;">CD</p>	<p style="text-align: center;">CE</p>	<p style="text-align: center;">CD</p>
<p style="text-align: center;">CE</p>	<p style="text-align: center;">CF</p>	<p style="text-align: center;">CE</p>
<p style="text-align: center;">CF</p>	<p style="text-align: center;">CG</p>	<p style="text-align: center;">CF</p>
<p style="text-align: center;">CG</p>	<p style="text-align: center;">CH</p>	<p style="text-align: center;">CG</p>
<p style="text-align: center;">CH</p>	<p style="text-align: center;">CI</p>	<p style="text-align: center;">CH</p>
<p style="text-align: center;">CI</p>	<p style="text-align: center;">CJ</p>	<p style="text-align: center;">CI</p>
<p style="text-align: center;">CJ</p>	<p style="text-align: center;">CK</p>	<p style="text-align: center;">CJ</p>
<p style="text-align: center;">CK</p>	<p style="text-align: center;">CL</p>	<p style="text-align: center;">CK</p>
<p style="text-align: center;">CL</p>	<p style="text-align: center;">CM</p>	<p style="text-align: center;">CL</p>
<p style="text-align: center;">CM</p>	<p style="text-align: center;">CN</p>	<p style="text-align: center;">CM</p>
<p style="text-align: center;">CN</p>	<p style="text-align: center;">CO</p>	<p style="text-align: center;">CN</p>
<p style="text-align: center;">CO</p>	<p style="text-align: center;">CP</p>	<p style="text-align: center;">CO</p>
<p style="text-align: center;">CP</p>	<p style="text-align: center;">CQ</p>	<p style="text-align: center;">CP</p>
<p style="text-align: center;">CQ</p>	<p style="text-align: center;">CR</p>	<p style="text-align: center;">CQ</p>
<p style="text-align: center;">CR</p>	<p style="text-align: center;">CS</p>	<p style="text-align: center;">CR</p>
<p style="text-align: center;">CS</p>	<p style="text-align: center;">CT</p>	<p style="text-align: center;">CS</p>
<p style="text-align: center;">CT</p>	<p style="text-align: center;">CV</p>	<p style="text-align: center;">CT</p>
<p style="text-align: center;">CV</p>	<p style="text-align: center;">CW</p>	<p style="text-align: center;">CV</p>
<p style="text-align: center;">CW</p>	<p style="text-align: center;">CX</p>	<p style="text-align: center;">CW</p>
<p style="text-align: center;">CX</p>	<p style="text-align: center;">CY</p>	<p style="text-align: center;">CX</p>
<p style="text-align: center;">CY</p>	<p style="text-align: center;">CA</p>	<p style="text-align: center;">CY</p>
<p style="text-align: center;">CA</p>	<p style="text-align: center;">CB</p>	<p style="text-align: center;">CA</p>
<p style="text-align: center;">CB</p>	<p style="text-align: center;">CC</p>	<p style="text-align: center;">CB</p>
<p style="text-align: center;">CC</p>	<p style="text-align: center;">CD</p>	<p style="text-align: center;">CC</p>
<p style="text-align: center;">CD</p>	<p style="text-align: center;">CE</p>	<p style="text-align: center;">CD</p>
<p style="text-align: center;">CE</p>	<p style="text-align: center;">CF</p>	<p style="text-align: center;">CE</p>
<p style="text-align: center;">CF</p>	<p style="text-align: center;">CG</p>	<p style="text-align: center;">CF</p>
<p style="text-align: center;">CG</p>	<p style="text-align: center;">CH</p>	<p style="text-align: center;">CG</p>
<p style="text-align: center;">CH</p>	<p style="text-align: center;">CI</p>	<p style="text-align: center;">CH</p>
<p style="text-align: center;">CI</p>	<p style="text-align: center;">CJ</p>	<p style="text-align: center;">CI</p>
<p style="text-align: center;">CJ</p>	<p style="text-align: center;">CK</p>	<p style="text-align: center;">CJ</p>
<p style="text-align: center;">CK</p>	<p style="text-align: center;">CL</p>	<p style="text-align: center;">CK</p>
<p style="text-align: center;">CL</p>	<p style="text-align: center;">CM</p>	<p style="text-align: center;">CL</p>
<p style="text-align: center;">CM</p>	<p style="text-align: center;">CN</p>	<p style="text-align: center;">CM</p>
<p style="text-align: center;">CN</p>	<p style="text-align: center;">CO</p>	<p style="text-align: center;">CN</p>
<p style="text-align: center;">CO</p>	<p style="text-align: center;">CP</p>	<p style="text-align: center;">CO</p>
<p style="text-align: center;">CP</p>	<p style="text-align: center;">CQ</p>	<p style="text-align: center;">CP</p>
<p style="text-align: center;">CQ</p>	<p style="text-align: center;">CR</p>	<p style="text-align: center;">CQ</p>
<p style="text-align: center;">CR</p>	<p style="text-align: center;">CS</p>	<p style="text-align: center;">CR</p>
<p style="text-align: center;">CS</p>	<p style="text-align: center;">CT</p>	<p style="text-align: center;">CS</p>
<p style="text-align: center;">CT</p>	<p style="text-align: center;">CV</p>	<p style="text-align: center;">CT</p>
<p style="text-align: center;">CV</p>	<p style="text-align: center;">CW</p>	<p style="text-align: center;">CV</p>
<p style="text-align: center;">CW</p>	<p style="text-align: center;">CX</p>	<p style="text-align: center;">CW</p>
<p style="text-align: center;">CX</p>	<p style="text-align: center;">CY</p>	<p style="text-align: center;">CX</p>
<p style="text-align: center;">CY</p>	<p style="text-align: center;">CA</p>	<p style="text-align: center;">CY</p>
<p style="text-align: center;">CA</p>	<p style="text-align: center;">CB</p>	<p style="text-align: center;">CA</p>
<p style="text-align: center;">CB</p>	<p style="text-align: center;">CC</p>	<p style="text-align: center;">CB</p>
<p style="text-align: center;">CC</p>	<p style="text-align: center;">CD</p>	<p style="text-align: center;">CC</p>
<p style="text-align: center;">CD</p>	<p style="text-align: center;">CE</p>	<p style="text-align: center;">CD</p>
<p style="text-align: center;">CE</p>	<p style="text-align: center;">CF</p>	<p style="text-align: center;">CE</p>
<p style="text-align: center;">CF</p>	<p style="text-align: center;">CG</p>	<p style="text-align: center;">CF</p>
<p style="text-align: center;">CG</p>	<p style="text-align: center;">CH</p>	<p style="text-align: center;">CG</p>
<p style="text-align: center;">CH</p>	<p style="text-align: center;">CI</p>	<p style="text-align: center;">CH</p>
<p style="text-align: center;">CI</p>	<p style="text-align: center;">CJ</p>	<p style="text-align: center;">CI</p>
<p style="text-align: center;">CJ</p>	<p style="text-align: center;">CK</p>	<p style="text-align: center;">CJ</p>
<p style="text-align: center;">CK</p>	<p style="text-align: center;">CL</p>	<p style="text-align: center;">CK</p>
<p style="text-align: center;">CL</p>	<p style="text-align: center;">CM</p>	<p style="text-align: center;">CL</p>
<p style="text-align: center;">CM</p>	<p style="text-align: center;">CN</p>	<p style="text-align: center;">CM</p>
<p style="text-align: center;">CN</p>	<p style="text-align: center;">CO</p>	<p style="text-align: center;">CN</p>

ACCESSORIES

These accessories were available when the tiller was purchased. They are also available at most Sears Retail outlets and Service Centers. Most Sears Stores can order repair parts for you when you provide the model number of your tiller.

ENGINE

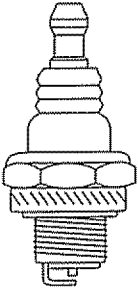
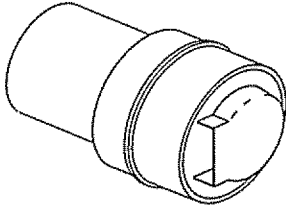
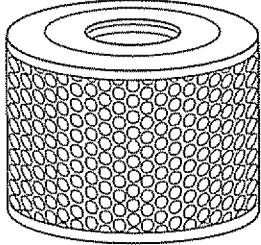
SPARK PLUG	MUFFLER	AIR FILTER
		

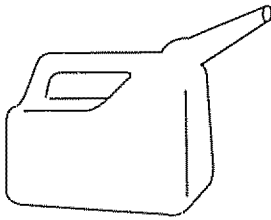
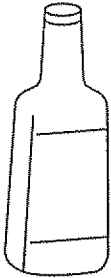
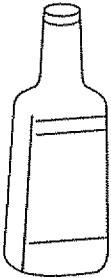
GAS CAN	ENGINE OIL	STABILIZER
		

TILLER PERFORMANCE

TILLER MAINTENANCE

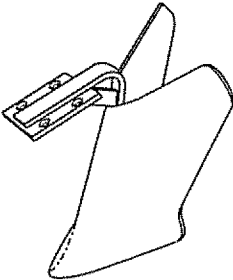
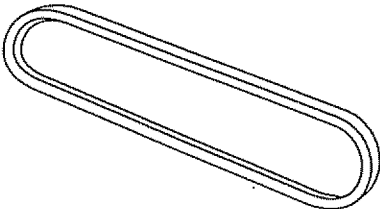
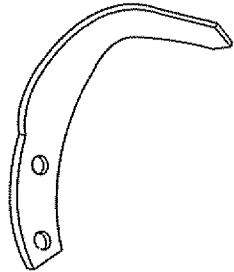
FURROW OPENER	BELT	TINES
		

ASSEMBLY

Your new tiller has been assembled at the factory with exception of those parts left unassembled for shipping purposes. To ensure safe and proper operation of your tiller all parts and hardware you assemble must be tightened securely. Use the correct tools as necessary to insure proper tightness.

TOOLS REQUIRED FOR ASSEMBLY

A socket wrench set will make assembly easier. Standard wrench sizes are listed.

- (1) Utility knife
- (1) Wire cutter
- (1) Screwdriver
- (1) Tire pressure gauge
- (1) Pair of pliers
- (1) 9/16" wrench

OPERATOR'S POSITION (See Fig. 1)

When right or left hand is mentioned in this manual, it means when you are in the operating position (standing behind tiller handles).

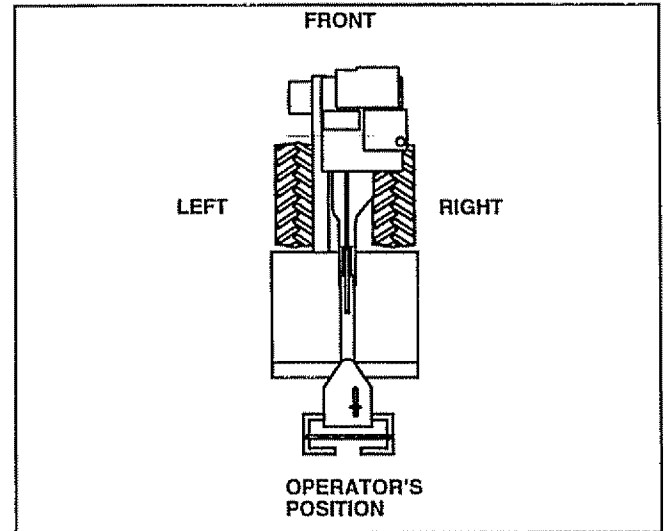
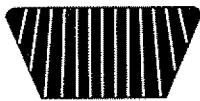
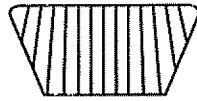

FIG. 1

CONTENTS OF HARDWARE PACK



(1) Handle Lock
(Black)



(1) Handle Lock
(Silver)

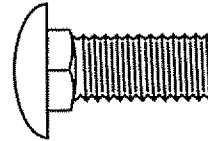

(2) Carriage Bolts
3/8-16 UNC x 1 Gr. 5



(2) Center Locknuts
3/8-16 UNC

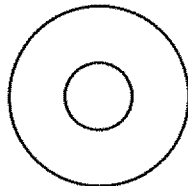

(1) Flat Washer 13/32 x 1 x 11 Ga.

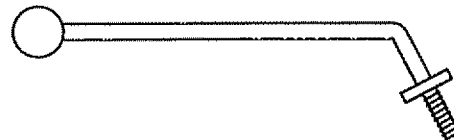

(1) Handle Lock Lever



(1) Hairpin Clip



(1) Cable Clip

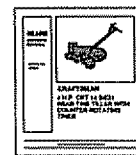

(1) Owner's Manual

ASSEMBLY

UNPACKING CARTON (See Fig. 2)



CAUTION: Be careful of exposed staples when handling or disposing of cartoning material.

IMPORTANT: WHEN UNPACKING AND ASSEMBLING TILLER, BE CAREFUL NOT TO STRETCH OR KINK CABLES.

- While holding handle assembly, cut cable ties securing handle assembly to top frame and depth stake. Let handle assembly rest on tiller.
- Remove top frame of carton.
- Slowly ease handle assembly up and place on top of carton.
- Cut down right hand front and right hand rear corners of carton. Lay side carton wall down.
- Cut down left hand rear corner of carton. Lay rear carton wall down, which will remove the protective cardboard flap from leveling shield.
- Remove packing material from handle assembly.

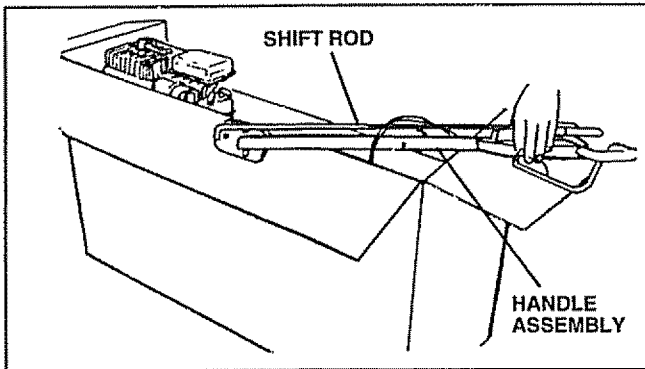

FIG. 2

INSTALL HANDLE (See Figs. 3, 4, and 5)

- Insert the thicker black handle lock (with teeth facing to the right) in gearcase notch.

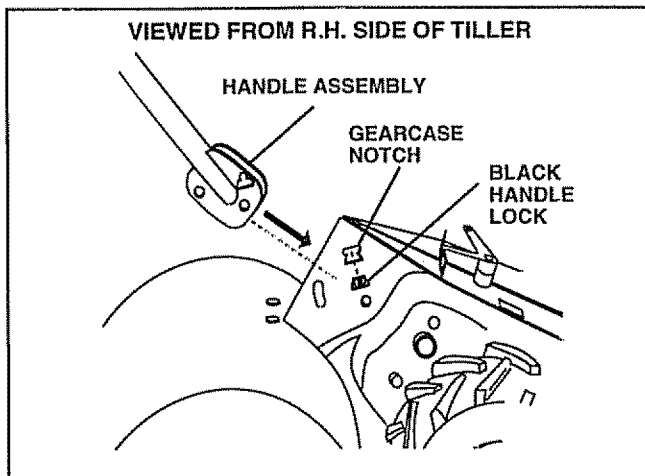

FIG. 3

- Grasp handle assembly. Hold in "up" position. Be sure handle lock remains in gearcase notch. Slide handle assembly into position.

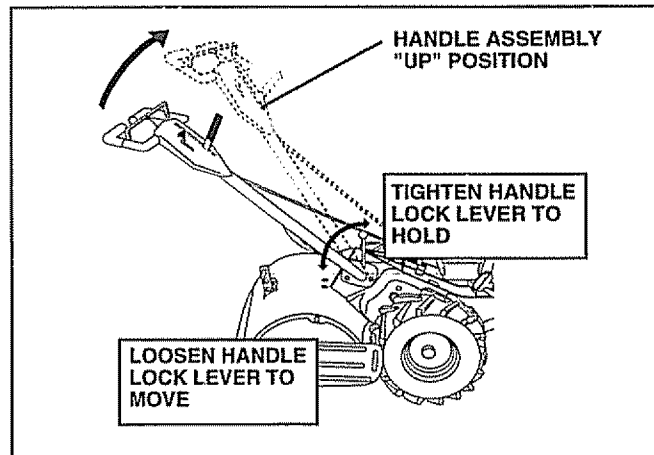

FIG. 4

- Rotate handle assembly down. Insert rear carriage bolt first, with bolt head on L.H. side of tiller (See Fig. 5).
- Insert front carriage bolt with care, since space for installation is limited.
- Lower the handle assembly. Tighten locknuts on bolts so handle moves with some resistance.
- Place flat washer on threaded end of handle lock lever.
- Insert handle lock lever through handle base and gearcase. Screw in handle lock lever just enough to hold lever in place.
- Insert the thinner silver handle lock (with teeth inward) in the slot of the handle base (just inside of washer).
- With handle assembly in lowest position, securely tighten handle lock by rotating clockwise. Leaving handle assembly in lowest position will make it easier to remove tiller from carton.

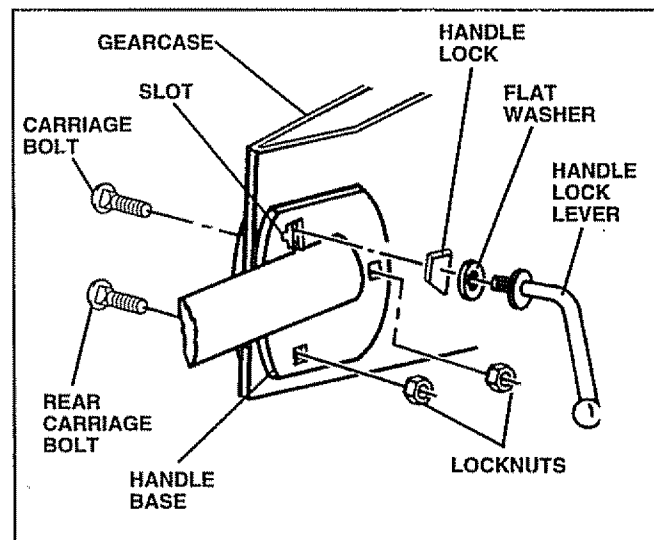

FIG. 5

ASSEMBLY

CONNECT SHIFT ROD (See Fig. 6)

- Insert end of shift rod into hole of shift lever indicator.
- Insert hairpin clip through hole of shift rod to secure.

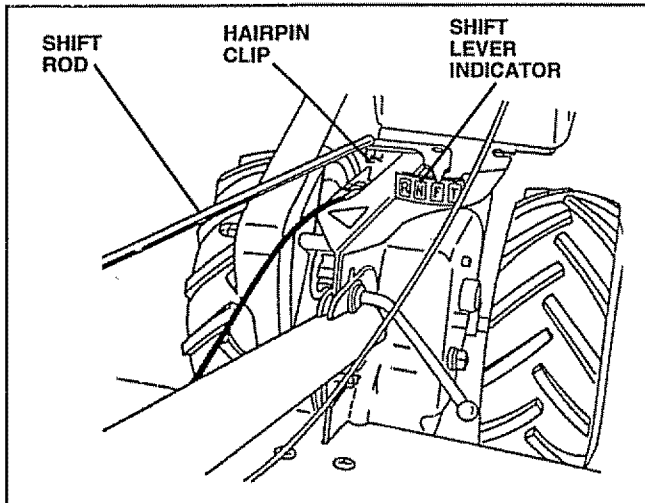

FIG. 6

REMOVE TILLER FROM CRATE

- Make sure shift lever indicator is in "N" (neutral) position (See Fig. 6)
- Tilt tiller forward by lifting handle.
- Rotate tiller handle to the right and pull tiller out of carton.

INSERT CABLE CLIP (See Fig. 7)

- Insert plastic cable clip into hole on the back of handle column. Push cables into clip.

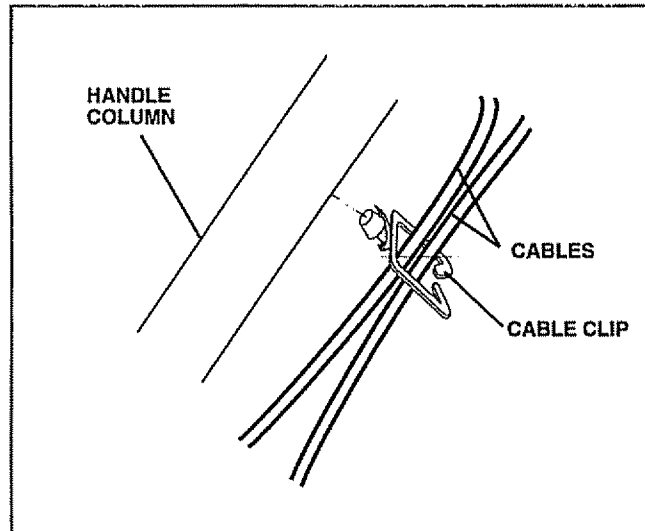

FIG. 7

CHECK TIRE PRESSURE

The tires on your tiller were overinflated at the factory for shipping purposes. Correct and equal tire pressure is important for best tilling performance.

- Reduce tire pressure to 20 PSI.

HANDLE HEIGHT

- Handle height may be adjusted to better suit operator. (See "TO ADJUST HANDLE HEIGHT" in the Service and Adjustments section of this manual).

OPERATION

KNOW YOUR TILLER

READ THIS OWNER'S MANUAL AND SAFETY RULES BEFORE OPERATING YOUR TILLER.

Compare the illustrations with your tiller to familiarize yourself with the location of various controls and adjustments. Save this manual for future reference.

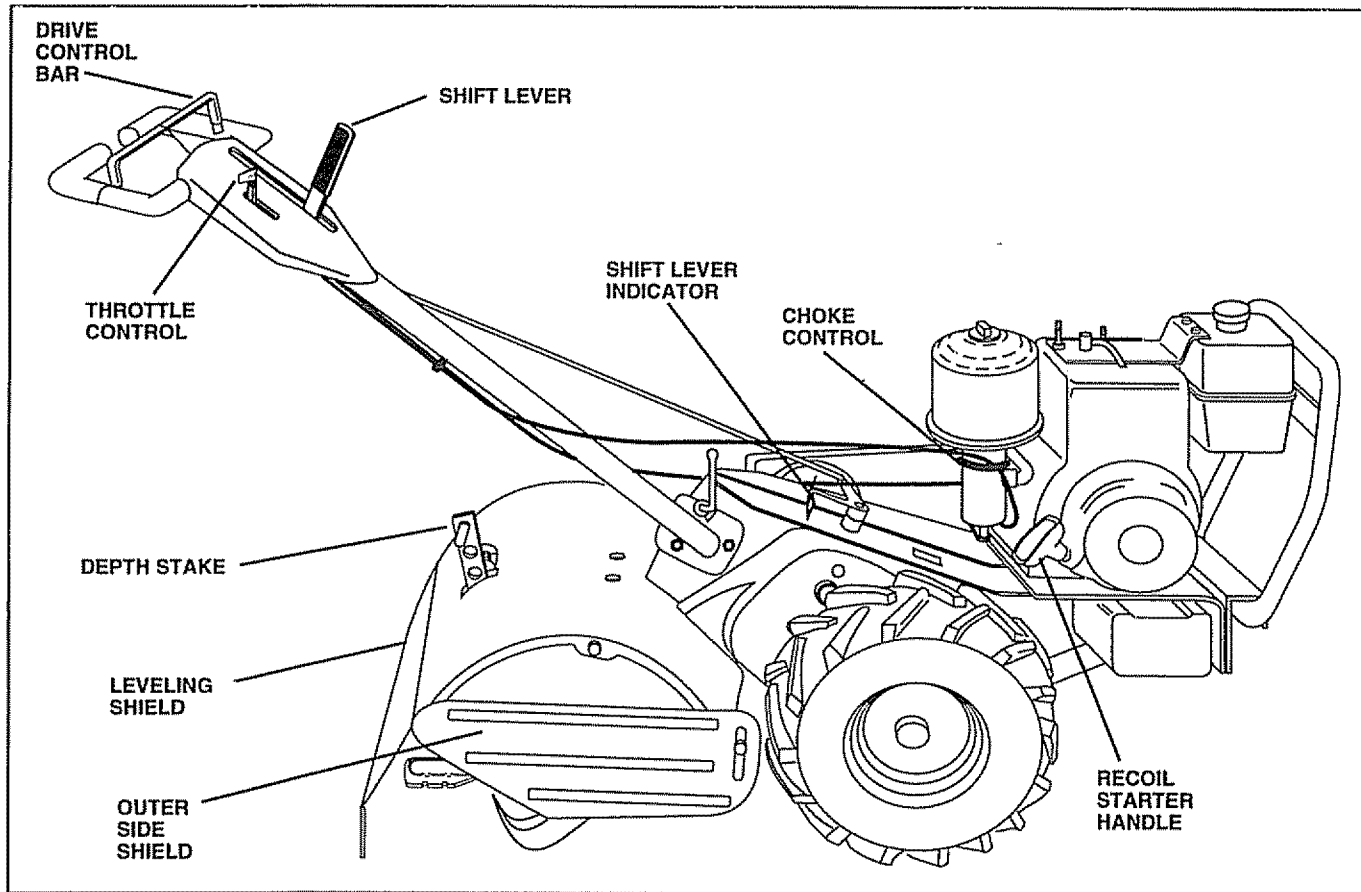

FIG. 8

MEETS ANSI SAFETY REQUIREMENTS

Our tillers conform to the safety standards of the American National Standards Institute.

DRIVE CONTROL BAR - Used to engage tines.

THROTTLE CONTROL - Used to control engine speed.

DEPTH STAKE - Controls depth at which tiller will dig.

LEVELING SHIELD - Levels tilled soil.

OUTER SIDE SHIELD - Adjustable to protect small plants from being buried.

SHIFT LEVER - Used to shift transmission gears.

SHIFT LEVER INDICATOR - Shows which gear the transmission is in.

CHOKE CONTROL - Used when starting a cold engine.

RECOIL STARTER HANDLE - Used to start the engine.

OPERATION



The operation of any tiller can result in foreign objects thrown into the eyes, which can result in severe eye damage. Always wear safety glasses or eye shields before starting your tiller and while tilling. We recommend a wide vision safety mask for over the spectacles or standard safety glasses.

HOW TO USE YOUR TILLER

Know how to operate all controls before adding fuel and oil or attempting to start engine.

STOPPING (See Fig. 9)

TINES AND DRIVE

- Release drive control bar to stop movement.
- Move shift lever to "N" (neutral) position.

ENGINE

- Move throttle control to "STOP" position.
- Never use choke to stop engine.

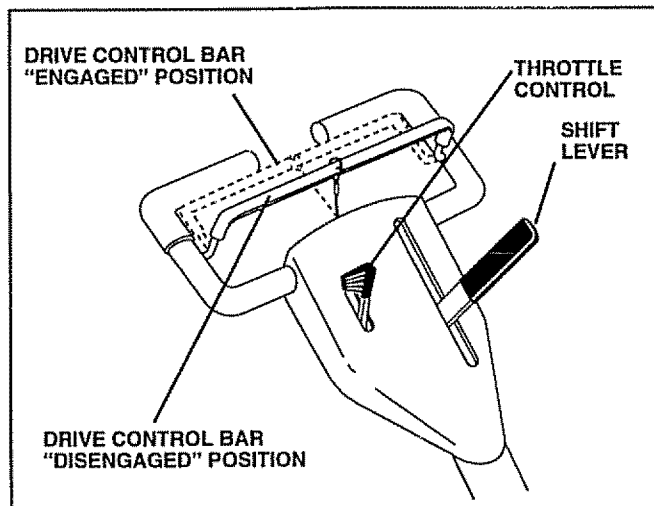

FIG. 9

TINE OPERATION - WITH WHEEL DRIVE

- Always release drive control bar before moving shift lever into another position.
- Tine movement is achieved by moving shift lever to "T" (till) position and engaging drive control bar.

FORWARD - WHEELS ONLY/TINES STOPPED

- Release drive control bar and move shift lever indicator to "F" (forward) position. Engage drive control bar and tiller will move forward.

REVERSE - WHEELS ONLY/TINES STOPPED

- DO NOT STAND DIRECTLY BEHIND TILLER.
- Release the drive control bar.
- Move throttle control to "SLOW" position.
- Move shift lever indicator to "R" (reverse) position.
- Hold drive control bar against the handle to start tiller movement.

DEPTH STAKE (See Fig. 10)

The depth stake can be raised or lowered to allow you more versatile tilling and cultivating, or to more easily transport your tiller.

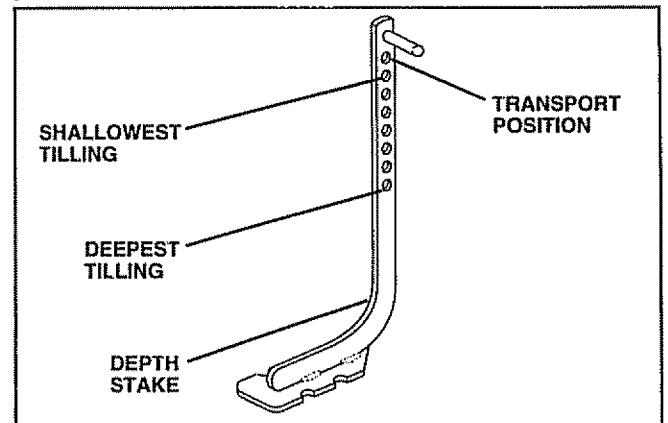

FIG. 10

TILLING (See Fig. 11)

- Release depth stake pin. Pull the depth stake up for increased tilling depth. Place depth stake pin in hole of depth stake to lock in position.
- Place shift lever indicator in "T" (till) position.
- Hold the drive control bar against the handle to start tilling movement. Tines and wheels will both turn.
- Move throttle control to "FAST" position for deep tilling. To cultivate, throttle control can be set at any desired speed, depending on how fast or slow you wish to cultivate.

IMPORTANT: ALWAYS RELEASE DRIVE CONTROL BAR BEFORE MOVING SHIFT LEVER INTO ANOTHER POSITION.

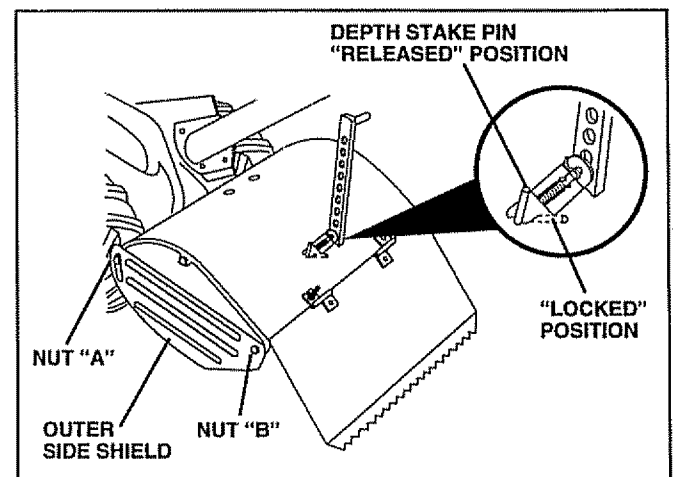

FIG. 11

OPERATION

TURNING

- Release the drive control bar.
- Move throttle control to "SLOW" position.
- Place shift lever indicator in "F" (forward) position. Tines will not turn.
- Lift handle to raise tines out of ground.
- Swing the handle in the opposite direction you wish to turn, being careful to keep feet and legs away from tines.
- When you have completed your turn-around, release the drive control bar and lower handle. Place shift lever in "T" (till) position and move throttle control to desired speed. To begin tilling, hold drive control bar against the handle.

OUTER SIDE SHIELDS (See Fig. 11)

The front edges of the outer side shields are slotted so that the shields can be raised for deep tilling and lowered for shallow tilling to protect small plants from being buried. Loosen nut "A" in slot and nut "B". Move shield to desired position (both sides). Retighten nuts.

TO TRANSPORT



CAUTION: Before lifting or transporting, allow tiller engine and muffler to cool. Disconnect spark plug wire. Drain gasoline from fuel tank.

AROUND THE YARD

- Release the depth stake pin. Move the depth stake down to the top hole for transporting the tiller. Place depth stake pin in hole of depth stake to lock in position. This prevents tines from scuffing the ground.
- Place shift lever indicator in "F" (forward) position for transporting.
- Hold the drive control bar against the handle to start tiller movement. Tines will not turn.
- Move throttle control to desired speed.

AROUND TOWN

- Disconnect spark plug wire.
- Drain fuel tank.
- Transport in upright position to prevent oil leakage.

BEFORE STARTING ENGINE

IMPORTANT: BE VERY CAREFUL NOT TO ALLOW DIRT TO ENTER THE ENGINE WHEN CHECKING OR ADDING OIL OR FUEL. USE CLEAN OIL AND FUEL AND STORE IN APPROVED, CLEAN, COVERED CONTAINERS. USE CLEAN FILL FUNNELS.

CHECK ENGINE OIL LEVEL (See Fig. 12)

- The engine in your tiller has been shipped, from the factory, already filled with SAE 30 summer weight oil.
- With engine level, clean area around oil filler plug and remove plug.
- Engine oil should be to point of overflowing. For approximate capacity see "PRODUCT SPECIFICATIONS" on page 3 of this manual. All oil must meet A.P.I. Service Classification SG.
- For cold weather operation you should change oil for easier starting (See oil viscosity chart in the Customer Responsibilities section of this manual).
- To change engine oil, see the Customer Responsibilities section in this manual.

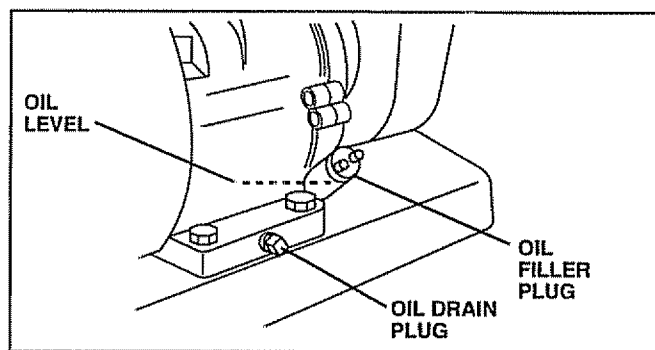

FIG. 12

ADD GASOLINE

- Fill fuel tank. Use fresh, clean, regular unleaded gasoline. (Use of leaded gasoline will increase carbon and lead oxide deposits and reduce valve life.

IMPORTANT: WHEN OPERATING IN TEMPERATURES BELOW 32°F (0°C), USE FRESH, CLEAN, WINTER GRADE GASOLINE TO HELP INSURE GOOD COLD WEATHER STARTING.

WARNING: Experience indicates that alcohol blended fuels (called gasohol or using ethanol or methanol) can attract moisture which leads to separation and formation of acids during storage. Acidic gas can damage the fuel system of an engine while in storage. To avoid engine problems, the fuel system should be emptied before storage of 30 days or longer. Drain the gas tank, start the engine and let it run until the fuel lines and carburetor are empty. Use fresh fuel next season. See Storage section of this manual for additional information. Never use engine or carburetor cleaner products in the fuel tank or permanent damage may occur.



CAUTION: Fill to within 1/2 inch of top of fuel tank to prevent spills and to allow for fuel expansion. If gasoline is accidentally spilled, move machine away from area of spill. Avoid creating any source of ignition until gasoline vapors have disappeared.

Do not overfill. Wipe off any spilled oil or fuel. Do not store, spill or use gasoline near an open flame.

OPERATION

TO START ENGINE (See Fig. 13)



CAUTION: Keep drive control bar in "DISENGAGED" position when starting engine.

- Make sure spark plug wire is properly connected, and fuel shut-off valve is open.
- Move shift lever indicator to "N" (neutral) position.
- Place throttle control in "FAST" position.
- With engine fully choked, grasp recoil starter handle with one hand and grasp tiller handle with other hand. Pull rope out slowly until engine reaches start of compression cycle (rope will pull slightly harder at this point).
- Pull recoil starter handle quickly. Do not let starter handle snap back against starter. Repeat if necessary in half choked position.
- When engine starts, slowly move choke control to "RUN" position as engine warms up.

NOTE: A warm engine requires less choking to start.

- Move throttle control to desired running position.
- Allow engine to warm up for a few minutes before engaging tines.

NOTE: If at a high altitude (above 3000 feet) or in cold temperatures (below 32°F), the carburetor fuel mixture may need to be adjusted for best engine performance. See "TO ADJUST CARBURETOR" in the Service and Adjustments section of this manual.

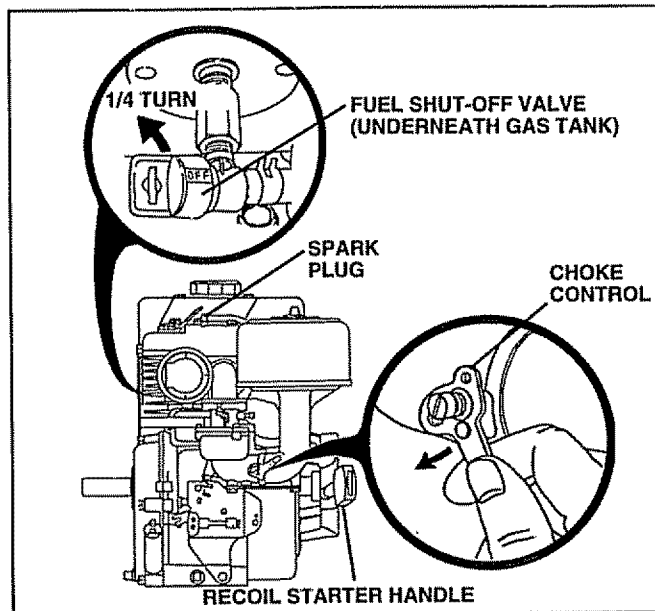

FIG. 13

TILLING HINTS



CAUTION: Until you are accustomed to handling your tiller, start actual field use with throttle in slow position.

- Tilling is digging into, turning over, and breaking up packed soil before planting. Loose, unpacked soil helps root growth. Best tilling depth is 4" to 6". A tiller will also clear the soil of unwanted vegetation. The decomposition of this vegetable matter enriches the soil. Depending on the climate (rainfall and wind), it may be advisable to till the soil at the end of the growing season to further condition the soil.
- For easier handling of your tiller, leave about 8 inches of untilled soil between the first and second tilling passes. The third pass will be between the first and second (See Fig. 14).
- Soil conditions are important for proper tilling. Tines will not readily penetrate dry, hard soil which may contribute to excessive bounce and difficult handling of your tiller. Hard soil should be moistened before tilling; however, extremely wet soil will "ball-up" or clump during tilling. Wait until the soil is less wet in order to achieve the best results. When tilling in the fall, remove vines and long grass to prevent them from wrapping around the tine shaft and slowing your tilling operation.
- Do not lean on handle. This takes weight off the wheels and reduces traction. To get through a really tough section of sod or hard ground, apply upward pressure on handle or lower the depth stake.

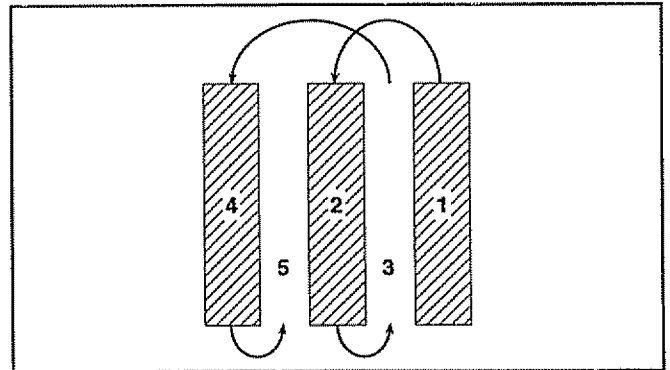

FIG. 14

OPERATION

CULTIVATING

Cultivating is destroying the weeds between rows to prevent them from robbing nourishment and moisture from the plants. At the same time, breaking up the upper layer of soil crust will help retain moisture in the soil. Best digging depth is 1" to 3". Lower the outer side shields to protect small plants from being buried.

- Cultivate up and down the rows at a speed which will allow tines to uproot weeds and leave the ground in rough condition, promoting no further growth of weeds and grass (See Fig. 15).

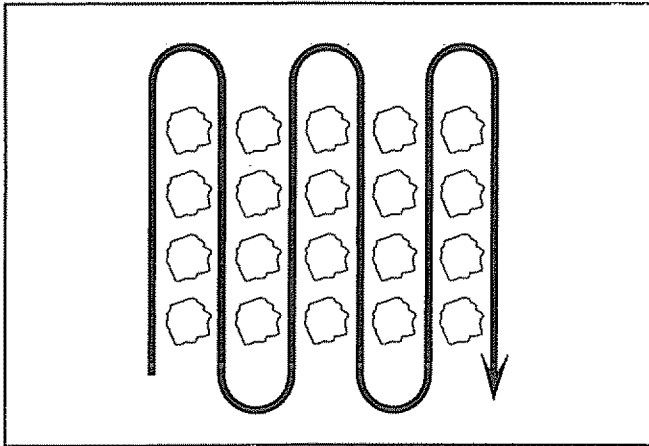

FIG. 15

ADJUST WHEELS FOR CULTIVATING (See Figs. 16 and 17)

- Place blocks under right hand side of tiller and remove hairpin clip and clevis pin from right hand wheel.
- Move wheel outward approximately 1 inch until hole in inner wheel hub lines up with inner hole in axle.
- Replace clevis pin and hairpin clip on inside of wheel and remove blocks.
- Repeat preceding steps on left hand side.

NOTE: In extremely rough conditions and while cultivating, the wheels should be moved outward on the axle for increased stability.

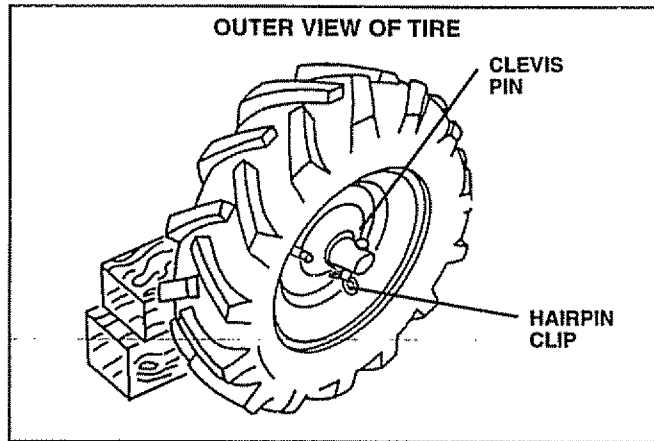

FIG. 16

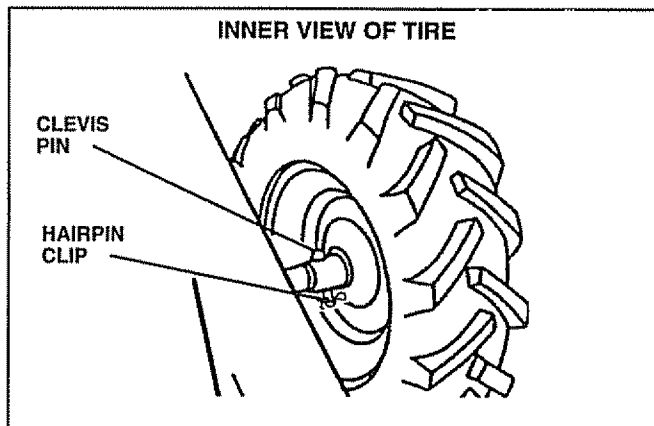

FIG. 17

CUSTOMER RESPONSIBILITIES

MAINTENANCE SCHEDULE						SERVICE DATES															
	BEFORE EACH USE	FIRST 2 HOURS	EVERY 5 HOURS	EVERY 25 HOURS	EVERY 50 HOURS																
FILL IN DATES AS YOU COMPLETE REGULAR SERVICE																					
Check Engine Oil Level	✓		✓																		
Change Engine Oil		✓		✓ _{1,2}																	
Oil Pivot Points			✓																		
Inspect Spark Arrester / Muffler					✓																
Inspect Air Screen	✓																				
Clean or Replace Air Cleaner Cartridge				✓ ₂																	
Clean Engine Cylinder Fins				✓																	
Replace Spark Plug					✓																

1 - Change more often when operating under a heavy load or in high ambient temperatures.
 2 - Service more often when operating in dirty or dusty conditions.

GENERAL RECOMMENDATIONS

The warranty on this tiller does not cover items that have been subjected to operator abuse or negligence. To receive full value from the warranty, the operator must maintain tiller as instructed in this manual.

Some adjustments will need to be made periodically to properly maintain your tiller.

All adjustments in the Service and Adjustments section of this manual should be checked at least once each season.

- Once a year you should replace the spark plug, clean or replace air filter, and check tines and belts for wear. A new spark plug and clean air filter assure proper air-fuel mixture and help your engine run better and last longer.

BEFORE EACH USE

- Check engine oil level.
- Check tine operation.
- Check for loose fasteners.

LUBRICATION

Keep unit well lubricated (See "LUBRICATION CHART").

LUBRICATION CHART

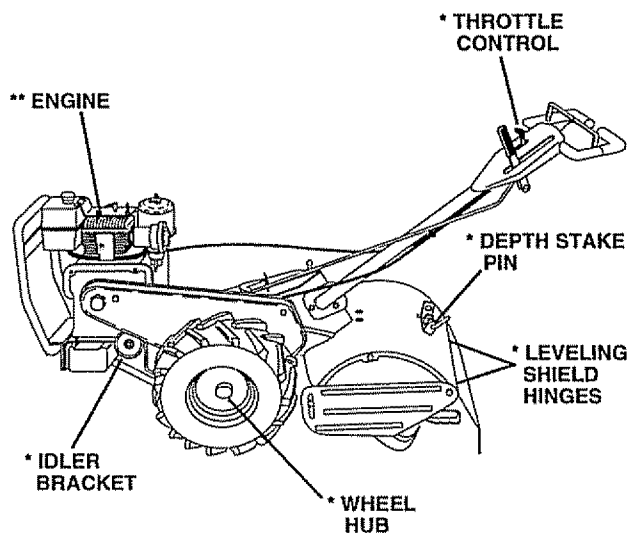

* SAE 30 OR 10W-30 MOTOR OIL

** REFER TO CUSTOMER RESPONSIBILITIES "ENGINE" SECTION

CUSTOMER RESPONSIBILITIES



Disconnect spark plug wire before performing any maintenance (except carburetor adjustment) to prevent accidental starting of engine.

Prevent fires! Keep the engine free of grass, leaves, spilled oil, or fuel. Remove fuel from tank before tipping unit for maintenance. Clean muffler area of all grass, dirt, and debris.

Do not touch hot muffler or cylinder fins as contact may cause burns.

ENGINE

LUBRICATION

Use only high quality detergent oil rated with API service classification SF or SG. Select the oil's SAE viscosity grade according to your expected temperature.

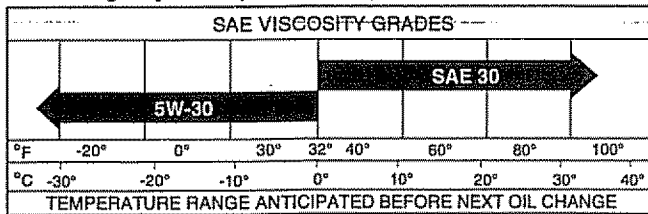

FIG. 18

NOTE: Although multi-viscosity oils (5W-30, 10W-30, etc.) improve starting in cold weather, these multi-viscosity oils will result in increased oil consumption when used above 32°F (0°C). Check your engine oil level more frequently to avoid possible engine damage from running low on oil.

Change the oil after the first two hours of operation and every 25 hours thereafter or at least once a year if the tiller is not used for 25 hours in one year.

Check the crankcase oil level before starting the engine and after each five (5) hours of continuous use. Add SAE 30 motor oil or equivalent. Tighten oil filler plug securely each time you check the oil level.

TO CHANGE ENGINE OIL (See Figs. 18 and 19)

Determine temperature range expected before oil change. All oil must meet API service classification SF or SG.

- Be sure tiller is on level surface.
- Oil will drain more freely when warm.
- Use a funnel to prevent oil spill on tiller, and catch oil in a suitable container.
- Remove drain plug.
- Tip tiller forward to drain oil.
- After oil has drained completely, replace oil drain plug and tighten securely.
- Remove oil filler plug. Be careful not to allow dirt to enter the engine.
- Refill engine with oil. See "CHECK ENGINE OIL LEVEL" in the Operation section of this manual.

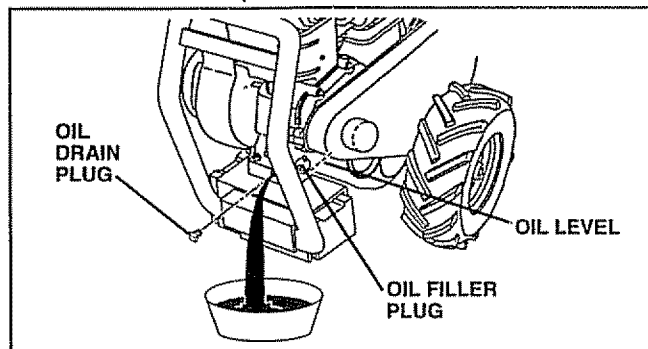

FIG. 19

AIR CLEANER (See Fig. 20)

Service air cleaner cartridge every 25 hours of operation, more often if engine is used in very dusty conditions.

- Remove the knob securing air cleaner cover.
- Remove air cleaner cover.
- Remove wing nut and cup.
- Carefully remove air cleaner cartridge. Be careful. Do not allow dirt or debris to fall into carburetor.
- Clean by tapping gently on a flat surface.
- If very dirty, replace or wash in a nonsudsing detergent and warm water solution. Rinse thoroughly with water flowing from mesh side until water is clear. Allow cartridge to stand and air dry thoroughly before using.
- Clean and replace cup, wing nut and cover. Tighten wing nut and knob securely.



CAUTION: Petroleum solvents, such as kerosene, are not to be used to clean cartridge. They may cause deterioration of the cartridge. Do not oil cartridge. Do not use pressurized air to clean or dry cartridge.

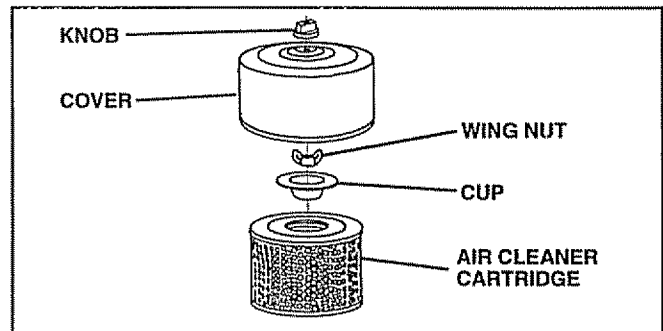

FIG. 20

COOLING SYSTEM (See Fig. 21)

Your engine is air cooled. For proper engine performance and long life keep your engine clean.

- Clean air screen frequently using a stiff-bristled brush.
- Remove blower housing and clean as necessary.
- Keep cylinder fins free of dirt and chaff.

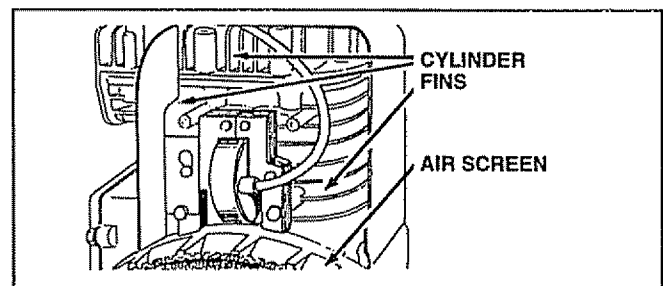

FIG. 21

CUSTOMER RESPONSIBILITIES

MUFFLER

Do not operate tiller without muffler. Do not tamper with exhaust system. Damaged mufflers or spark arresters could create a fire hazard. Inspect periodically and replace if necessary. If your engine is equipped with a spark arrester screen assembly, remove every 50 hours for cleaning and inspection. Replace if damaged.

SPARK PLUG

Replace spark plugs at the beginning of each tilling season or after every 50 hours of use, whichever comes first. Spark plug type and gap setting is shown in "PRODUCT SPECIFICATIONS" on page 3 of this manual.

TRANSMISSION

Your transmission is sealed and will only require lubrication if serviced.

CLEANING

- Clean engine, wheels, finish, etc. of all foreign matter.
- Keep finished surfaces and wheels free of all gasoline, oil, etc.
- Protect painted surfaces with automotive type wax.

We do not recommend using a garden hose to clean your unit unless the muffler, air filter and carburetor are covered to keep water out. Water in engine can result in a shortened engine life.

SERVICE AND ADJUSTMENTS



CAUTION: Disconnect spark plug wire from spark plug and place wire where it cannot come into contact with plug.

TILLER

TO ADJUST HANDLE HEIGHT (See Fig. 22)

Select handle height best suited for your tilling conditions. Handle height will be different when tiller digs into soil.

- First loosen handle lock lever.
- Handle can be positioned at different settings between "HIGH" and "LOW" positions.
- Retighten handle lock lever securely after adjusting.

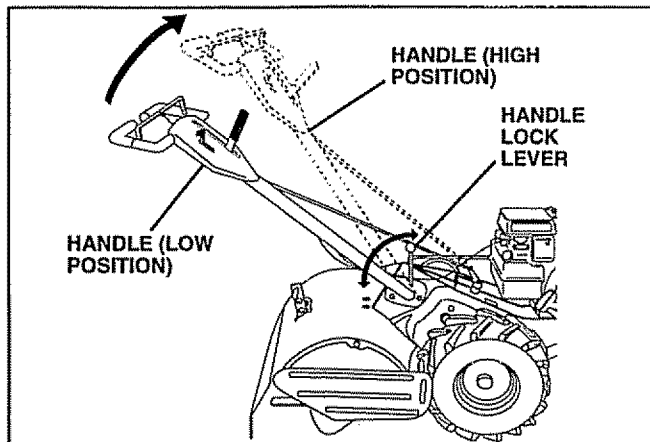

FIG. 22

TIRE CARE



CAUTION: When mounting tires, unless beads are seated, overinflation can cause an explosion.

- Maintain 20 pounds of tire pressure. If tire pressures are not equal, tiller will pull to one side.
- Keep tires free of gasoline or oil which can damage rubber.

TO REMOVE WHEEL (See Fig. 23)

- Place blocks under transmission to keep tiller from tipping.
- Remove hairpin clip and clevis pin from wheel.
- Remove wheel and tire.
- Repair tire and reassemble.

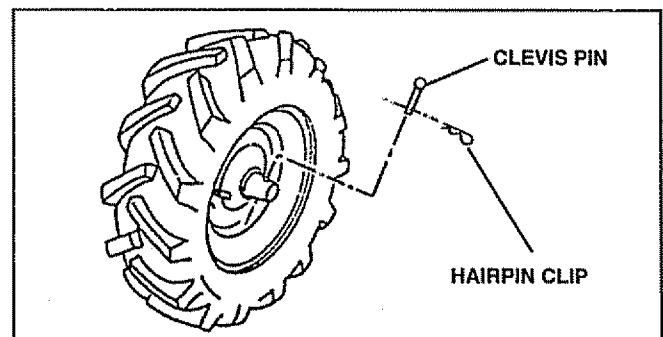

FIG. 23

SERVICE AND ADJUSTMENTS

TO REMOVE BELT GUARD (See Fig. 24)

- Remove hairpin clip and clevis pin from left wheel. Pull wheel out from tiller about 1 inch.
- Remove cap nut and washer, and 13/16 bolt and washer from side of belt guard.
- Remove hex nut and washer from bottom of belt guard (located behind wheel).
- Pull belt guard out and away from tiller.
- Replace belt guard by reversing above procedure.

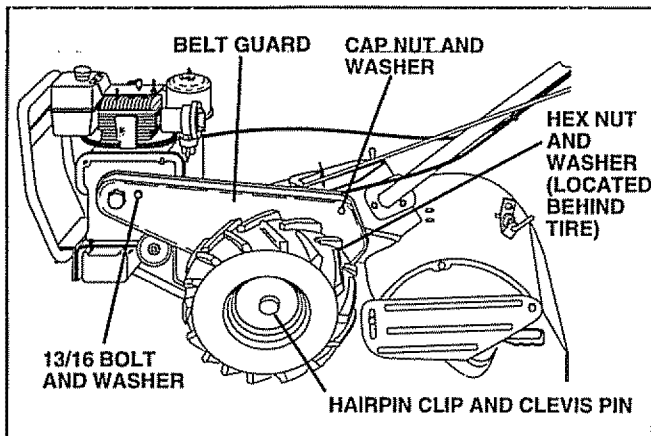

FIG. 24

TO REPLACE GROUND DRIVE BELT (See Fig. 25)

- Remove belt guard. (See "TO REMOVE BELT GUARD" in this section of this manual).
- Loosen belt guides "A" and "B".
- Remove old belt by slipping from engine pulley first.
- Place new belt in groove of transmission pulley and into engine pulley. BELT MUST BE IN GROOVE ON TOP OF IDLER PULLEY. NOTE POSITION OF BELT TO GUIDES.
- Tighten belt guides "A" and "B".
- Check belt adjustment as described below.
- Replace belt guard.
- Reposition wheel and replace clevis pin and hairpin clip.

GROUND DRIVE BELT ADJUSTMENT (See Fig. 25)

For proper belt tension, the extension spring should have about 5/8 inch stretch when drive control bar is in "ENGAGED" position. This tension can be attained as follows:

- Loosen cable clip screw securing the drive control cable.
- Slide cable forward for less tension and rearward for more tension until about 5/8 inch stretch is obtained while the drive control bar is engaged.
- Tighten cable clip screw securely.

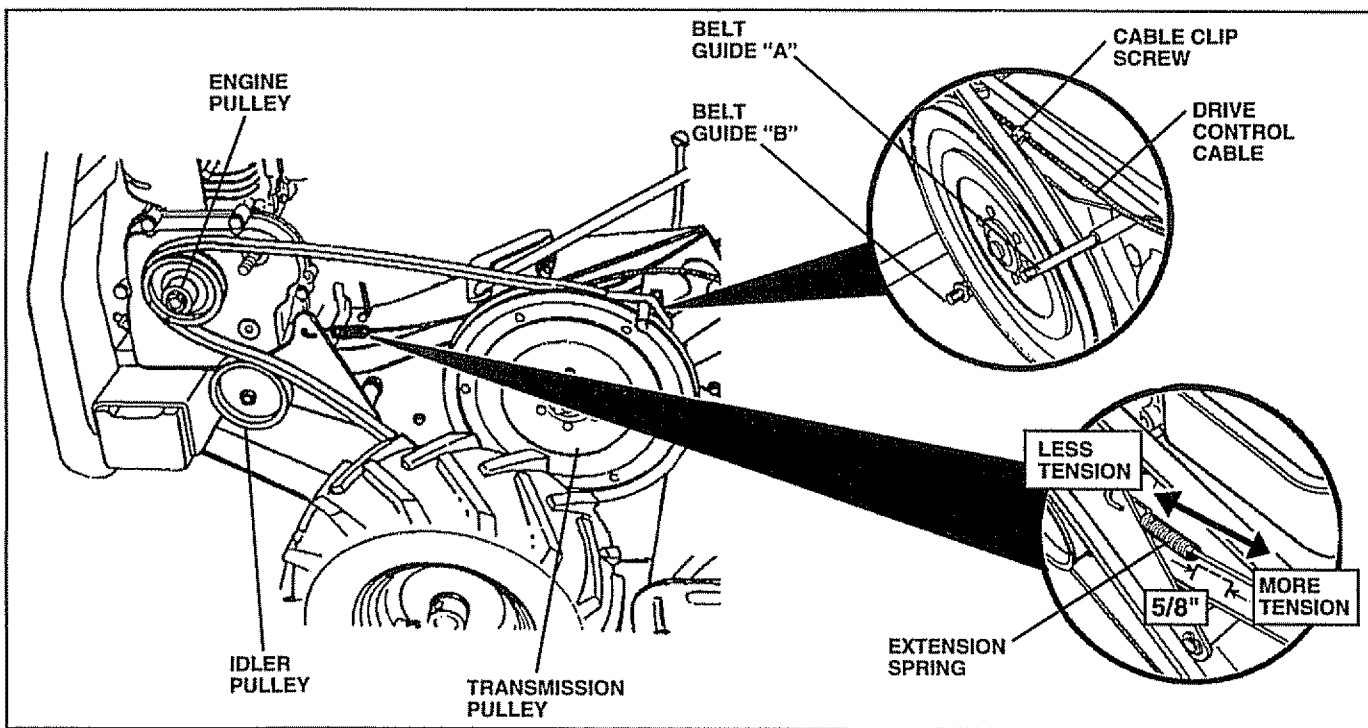

FIG. 25

SERVICE AND ADJUSTMENTS

TINE REPLACEMENT (See Figs. 26, 27 and 28)



CAUTION: Tines are sharp. Wear gloves or other protection when handling tines.

A badly worn tine causes your tiller to work harder and dig more shallow. Most important, worn tines cannot chop and shred organic matter as effectively nor bury it as deeply as good tines. A tine this worn needs to be replaced.

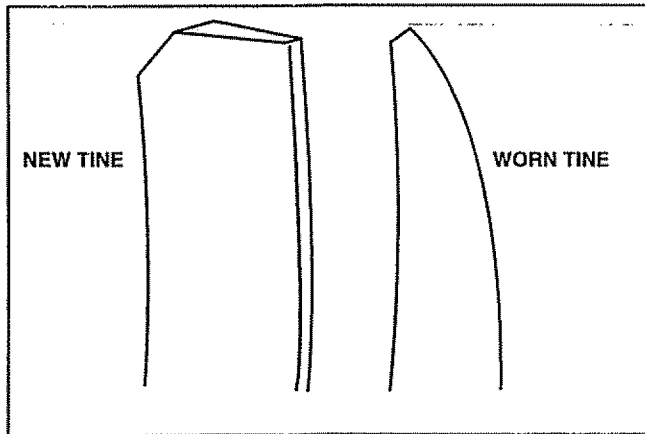

FIG. 26

- To maintain the superb tilling performance of this machine the tines should be checked for sharpness, wear, and bending, particularly the tines which are next to the transmission. If the gap between the tines exceeds 3-1/2 inches they should be replaced or straightened as necessary.
- New tines should be assembled as shown in Fig. 28. Sharpened tine edges will rotate rearward from above.

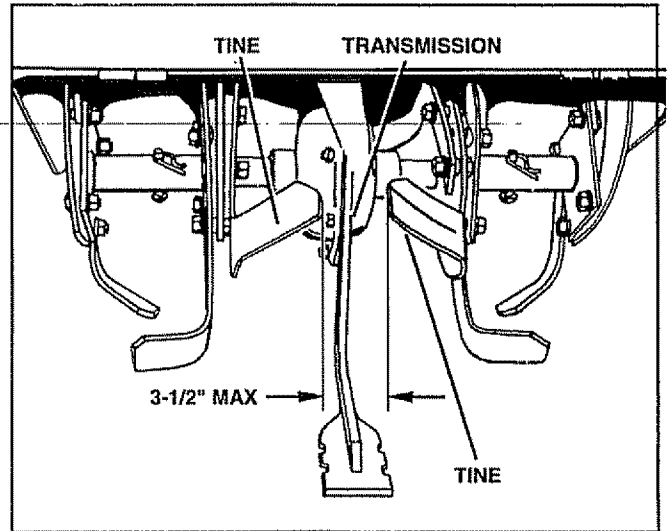

FIG. 27

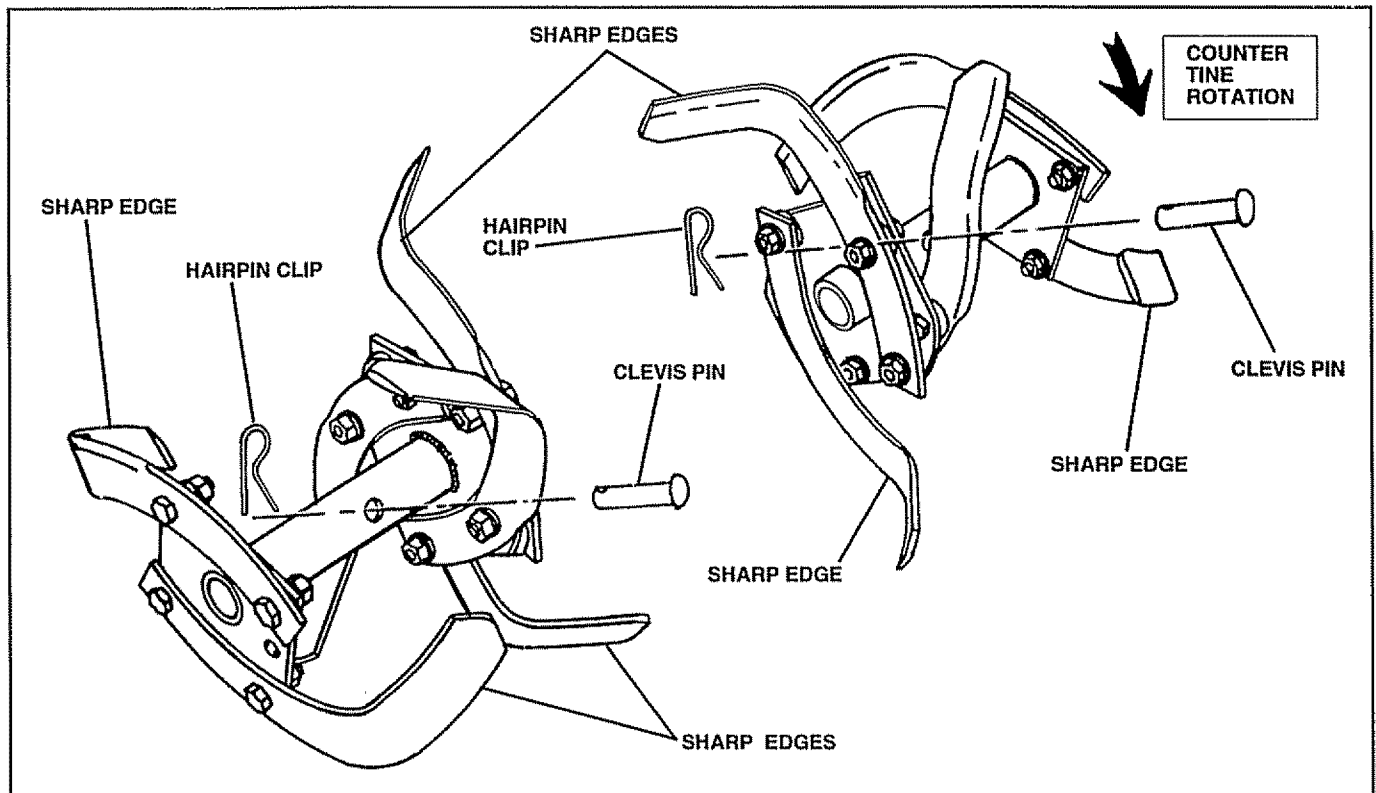

FIG. 28

SERVICE AND ADJUSTMENTS

ENGINE

TO ADJUST THROTTLE CONTROL CABLE (See Fig. 29)

The throttle control has been preset at the factory and adjustment should not be necessary. Check adjustment as described below before loosening cable. If adjustment is necessary, proceed as follows:

- With engine not running, move remote throttle control lever to "FAST" position.
- Check that holes "A" in governor control lever and hole in governor plate line-up. If holes "A" are not aligned, loosen clamp screw and move throttle cable until holes are aligned. Tighten clamp screw securely.

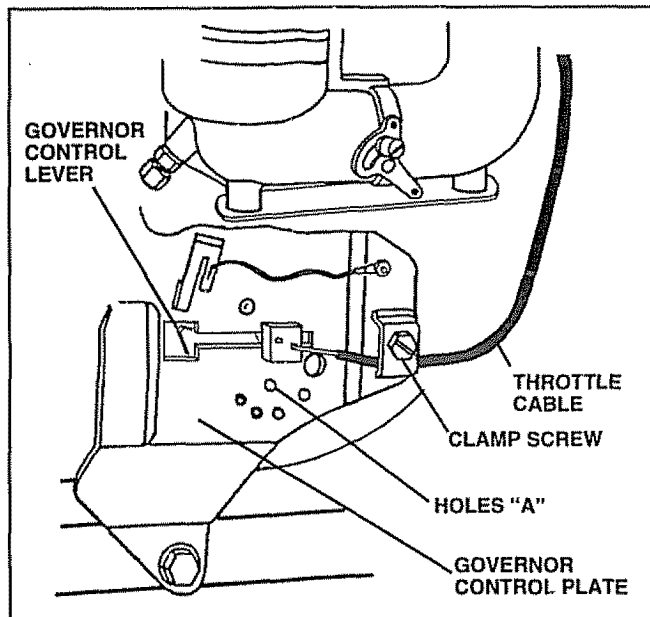

FIG. 29

TO ADJUST CARBURETOR (See Fig. 30)

The carburetor has been preset at the factory and adjustment should not be necessary. However, minor adjustment may be required to compensate for differences in fuel, temperature, altitude or load. If the carburetor does need adjustment, proceed as follows:

In general, turning valves **in** (clockwise) decreases the supply of fuel to the engine giving a leaner fuel/air mixture. Turning the valve **out** (counterclockwise) increases the supply of fuel to the engine giving a richer fuel/air mixture.

IMPORTANT: DAMAGE TO THE VALVE AND THE SEAT IN CARBURETOR MAY RESULT IF SCREW IS TURNED IN TOO TIGHT.

PRELIMINARY SETTING

- Air cleaner assembly must be assembled to the carburetor when making carburetor adjustments.
- Be sure the throttle control cable is adjusted properly (see above).
- With engine off turn idle mixture valve **in** (clockwise) closing it finger tight and then turn **out** (counterclockwise) 1 full turn.
- Turn needle valve **in** (clockwise) closing it finger tight and then **out** (counterclockwise) 1-1/2 turns.

FINAL SETTING

- Start engine and allow to warm for five minutes. Make final adjustments with engine running and drive control bar in "NEUTRAL" position.
- Move remote throttle control lever to "FAST" position. Turn needle valve **in** (clockwise) until engine begins to die and then turn **out** (counterclockwise) until engine runs rough. Turn valve to a point midway between those two positions. Release throttle control lever.
- Move remote throttle control lever to "SLOW" position. Rotate and hold throttle against idle speed screw. Turn idle speed screw to attain 1850 RPM.
- While still holding throttle against idle speed screw, turn idle mixture valve **in** (clockwise) until engine begins to die and then turn **out** (counterclockwise) until engine runs rough. Turn valve to a point midway between those two positions. Release throttle.

ACCELERATION TEST

- Move remote throttle control lever from "SLOW" to "FAST" position. If engine hesitates or dies, turn idle mixture valve **out** (counterclockwise) 1/8 turn. Repeat test and continue to adjust, if necessary, until engine accelerates smoothly.

High speed stop is factory adjusted. Do not adjust - damage may result.

IMPORTANT: NEVER TAMPER WITH THE ENGINE GOVERNOR, WHICH IS FACTORY SET FOR PROPER ENGINE SPEED. OVERSPEEDING THE ENGINE ABOVE THE FACTORY HIGH SPEED SETTING CAN BE DANGEROUS. IF YOU THINK THE ENGINE-GOVERNED HIGH SPEED NEEDS ADJUSTING, CONTACT YOUR NEAREST AUTHORIZED SERVICE CENTER/DEPARTMENT, WHICH HAS PROPER EQUIPMENT AND EXPERIENCE TO MAKE ANY NECESSARY ADJUSTMENTS.

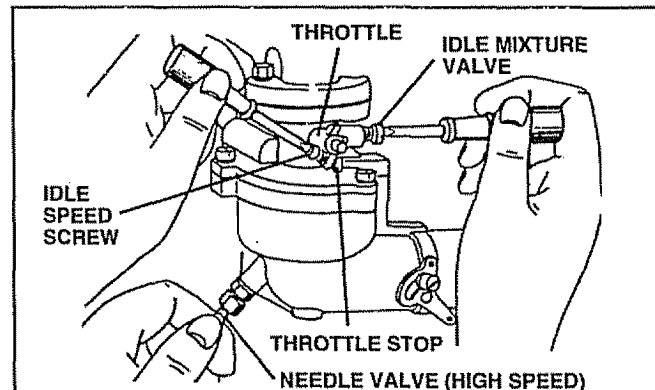

FIG. 30

STORAGE

Immediately prepare your tiller for storage at the end of the season or if the unit will not be used for 30 days or more.



CAUTION: Never store the tiller with gasoline in the tank inside a building where fumes may reach an open flame or spark. Allow the engine to cool before storing in any enclosure.

TILLER

- Clean entire tiller (See "CLEANING" in the Customer Responsibilities section of this manual).
- Inspect and replace belts, if necessary (See belt replacement instructions in the Service and Adjustments section of this manual).
- Lubricate as shown in the Customer Responsibilities section of this manual.
- Be sure that all nuts, bolts and screws are securely fastened. Inspect moving parts for damage, breakage and wear. Replace if necessary.
- Touch up all rusted or chipped paint surfaces; sand lightly before painting.

ENGINE

FUEL SYSTEM

IMPORTANT: IT IS IMPORTANT TO PREVENT GUM DEPOSITS FROM FORMING IN ESSENTIAL FUEL SYSTEM PARTS SUCH AS THE CARBURETOR, FUEL FILTER, FUEL HOSE, OR TANK DURING STORAGE. ALSO, EXPERIENCE INDICATES THAT ALCOHOL BLENDED FUELS (CALLED GASOHOL OR USING ETHANOL OR METHANOL) CAN ATTRACT MOISTURE WHICH LEADS TO SEPARATION AND FORMATION OF ACIDS DURING STORAGE. ACIDIC GAS CAN DAMAGE THE FUEL SYSTEM OF AN ENGINE WHILE IN STORAGE.

- Drain the fuel tank.
- Start the engine and let it run until the fuel lines and carburetor are empty.
- Never use engine or carburetor cleaner products in the fuel tank or permanent damage may occur.
- Use fresh fuel next season.

NOTE: Fuel stabilizer is an acceptable alternative in minimizing the formation of fuel gum deposits during storage. Add stabilizer to gasoline in fuel tank or storage container. Always follow the mix ratio found on stabilizer container. Run engine at least 10 minutes after adding stabilizer to allow the stabilizer to reach the carburetor. Do not drain the gas tank and carburetor if using fuel stabilizer.

ENGINE OIL

Drain oil (with engine warm) and replace with clean oil. (See "ENGINE" in the Customer Responsibilities section of this manual).

CYLINDERS

- Remove spark plug.
- Pour 1 ounce (29 ml) of oil through spark plug hole into cylinder.
- Pull starter handle slowly several times to distribute oil.
- Replace with new spark plug.

OTHER

- Do not store gasoline from one season to another.
- Replace your gasoline can if your can starts to rust. Rust and/or dirt in your gasoline will cause problems.
- If possible, store your unit indoors and cover it to give protection from dust and dirt.
- Cover your unit with a suitable protective cover that does not retain moisture. Do not use plastic. Plastic cannot breathe which allows condensation to form and will cause your unit to rust.

IMPORTANT: NEVER COVER TILLER WHILE ENGINE AND EXHAUST AREAS ARE STILL WARM.

TROUBLESHOOTING POINTS

PROBLEM	CAUSE	CORRECTION
Will not start	<ol style="list-style-type: none"> 1. Out of fuel. 2. Engine not "CHOKED" properly. 3. Engine flooded. 4. Dirty air cleaner. 5. Water in fuel. 6. Clogged fuel tank. 7. Loose spark plug wire. 8. Bad spark plug or improper gap. 9. Carburetor out of adjustment. 10. Fuel shut-off valve is closed. 	<ol style="list-style-type: none"> 1. Fill fuel tank. 2. See "TO START ENGINE" in Operation section. 3. Wait several minutes before attempting to start. 4. Clean or replace air cleaner cartridge. 5. Drain fuel tank & carburetor, refill tank with fresh gas. 6. Remove fuel tank and clean. 7. Make sure spark plug wire is seated properly on plug. 8. Replace spark plug or adjust gap. 9. Make necessary adjustments. 10. Open valve.
Hard to start	<ol style="list-style-type: none"> 1. Throttle control not set properly. 2. Dirty air cleaner. 3. Bad spark plug or improper gap. 4. Stale or dirty fuel. 5. Loose spark plug wire. 6. Carburetor out of adjustment. 	<ol style="list-style-type: none"> 1. Place throttle control in "FAST" position. 2. Clean or replace air cleaner cartridge. 3. Replace spark plug or adjust gap. 4. Drain fuel tank and refill with fresh gasoline. 5. Make sure spark plug wire is seated properly on plug. 6. Make necessary adjustments.
Loss of power	<ol style="list-style-type: none"> 1. Engine is overloaded. 2. Dirty air cleaner. 3. Low oil level/dirty oil. 4. Faulty spark plug. 5. Oil in fuel. 6. Stale or dirty fuel. 7. Water in fuel. 8. Clogged fuel tank. 9. Spark plug wire loose. 10. Dirty engine air screen. 11. Dirty/clogged muffler. 12. Carburetor out of adjustment. 13. Poor compression. 	<ol style="list-style-type: none"> 1. Set depth stake for shallower tilling. 2. Clean or replace air cleaner cartridge. 3. Check oil level/change oil. 4. Clean and regap or change spark plug. 5. Drain & clean fuel tank and refill, and clean carburetor. 6. Drain fuel tank and refill with fresh gasoline. 7. Drain fuel tank & carburetor, refill tank with fresh gas. 8. Remove fuel tank and clean. 9. Connect and tighten spark plug wire. 10. Clean engine air screen. 11. Clean/replace muffler. 12. Make necessary adjustments. 13. Contact an authorized service center/department.
Engine overheats	<ol style="list-style-type: none"> 1. Low oil level/dirty oil. 2. Dirty engine air screen. 3. Dirty engine. 4. Partially plugged muffler. 5. Improper carburetor adjustment. 	<ol style="list-style-type: none"> 1. Check oil level/change oil. 2. Clean engine air screen. 3. Clean cylinder fins, air screen, and muffler area. 4. Remove and clean muffler. 5. Adjust carburetor to richer position.
Excessive bounce/ difficult handling	<ol style="list-style-type: none"> 1. Ground too dry and hard 	<ol style="list-style-type: none"> 1. Moisten ground or wait for more favorable soil conditions.
Soil balls up or clumps	<ol style="list-style-type: none"> 1. Ground too wet 	<ol style="list-style-type: none"> 1. Wait for more favorable soil conditions.
Engine runs but tiller won't move	<ol style="list-style-type: none"> 1. Drive control bar is not engaged. 2. V-belt not correctly adjusted. 3. V-belt is off pulley(s). 	<ol style="list-style-type: none"> 1. Engage drive control. 2. Inspect/adjust V-belt. 3. Inspect V-belt.
Engine runs but labors when tilling	<ol style="list-style-type: none"> 1. Tilling too deep. 2. Throttle control not properly adjusted. 3. Carburetor out of adjustment. 	<ol style="list-style-type: none"> 1. Set depth stake for shallower tilling. 2. Check throttle control setting. 3. Make necessary adjustments.

REPAIR PARTS

8 HP 21" TILLER - - MODEL NUMBER 917.299881

HANDLES

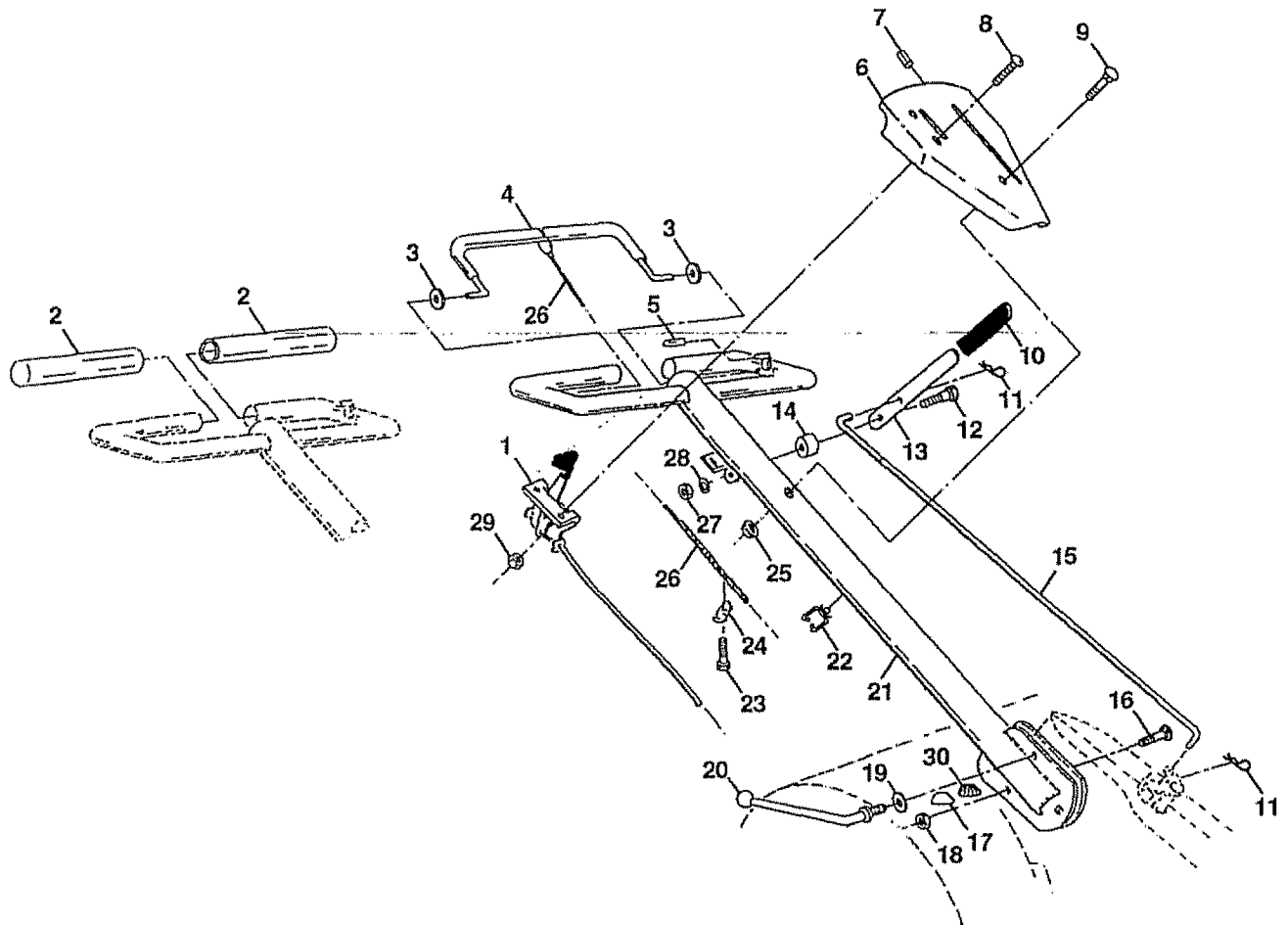

KEY NO.	PART NO.	DESCRIPTION
1	138305	Throttle Control
2	141406	Grip, Handle
3	110673X	Grommet, Handle
4	127254X	Bar, Drive Control Assembly
5	6712J	Cap, Vinyl
6	137119	Panel, Control
7	110641X	Bushing, Split
8	71191008	Screw, Machine, Pan Head, #10-24
9	STD533125	Bolt, Carriage
10	110646X	Handle, Grip
11	STD624003	Clip, Hairpin
12	81328	Bolt, Shoulder
13	138295	Handle, Shift
14	109313X	Grommet, Rubber
15	138296	Rod, Shift
16	STD533710	Bolt, Carriage 3/8-16 x 1 Grade 5
17	109229X	Lock, Handle, Silver
18	STD541437	Nut, Hex, Centerlock 3/8-16

KEY NO.	PART NO.	DESCRIPTION
19	19131611	Washer 13/32 x 1 x 11 Gauge
20	109228X	Lever, Lock, Handle
21	138297	Handle, Assemble
22	121145X	Clip, Plastic, Cable
23	86777	Screw, Hex Washer Head, Slotted #10-24 x 1/2
24	9484R	Clip
25	73970500	Locknut, Hex, Flange
26	138306	Clutch, Cable
27	STD541025	Nut, Hex 1/4-20
28	STD551125	Washer, Lock 1/4
29	STD541462	Nut, Hex, Keps #10-24
30	138283	Lock, Handle, Black

NOTE: All component dimensions given in U.S. inches.
1 inch = 25.4 mm

REPAIR PARTS

8 HP 21" TILLER - - MODEL NUMBER 917.299881

MAINFRAME, LEFT SIDE

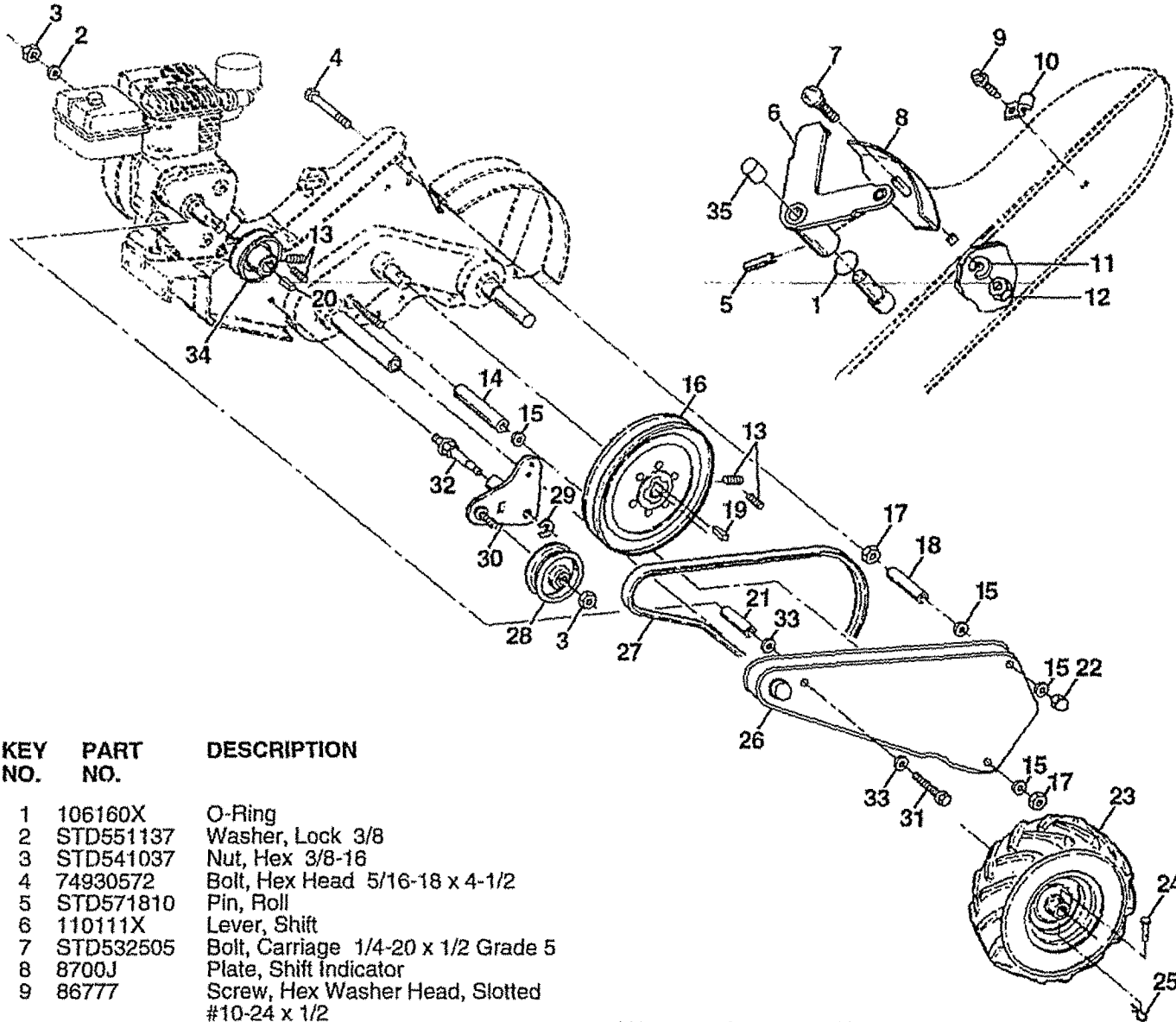

KEY NO.	PART NO.	DESCRIPTION
1	106160X	O-Ring
2	STD551137	Washer, Lock 3/8
3	STD541037	Nut, Hex 3/8-16
4	74930572	Bolt, Hex Head 5/16-18 x 4-1/2
5	STD571810	Pin, Roll
6	110111X	Lever, Shift
7	STD532505	Bolt, Carriage 1/4-20 x 1/2 Grade 5
8	8700J	Plate, Shift Indicator
9	86777	Screw, Hex Washer Head, Slotted #10-24 x 1/2
10	9484R	Clip
11	STD551125	Washer, Lock 1/4
12	STD541025	Nut, Hex 1/4-20
13	23230506	Screw, Set, Hex 5/16-18 x 3/8
14	8382J	Spacer, Split 0.327 x 0.42 x 2.68
15	STD551031	Washer 11/32 x 11/16 x 16 Gauge
16	100473M	Sheave, Transmission
17	STD541031	Nut, Hex 5/16-18
18	8381J	Spacer
19	2649M	Key, Square 3/16 x 1-1/8
20	4914H	Key, Square
21	139155	Spacer, Split .523 x .718 x 2
22	104214X	Nut, Cap 5/16-18
23	5015J	Tire
	138417	Rim
	795R	Tire Valve
24	4929H	Rivet, Drilled

KEY NO.	PART NO.	DESCRIPTION
25	STD624003	Clip, Hairpin
26	102818X459	Guard, Belt
27	138399	V-Belt
28	104680X	Pulley, Idler
29	12000032	Ring, Klip
30	105611X	Bracket, Idler
31	74770844	Bolt, Hex Head 1/2-20 x 2-3/4
32	139401	Shaft, Idler Arm
33	STD551050	Washer
34	4368J	Sheave, Engine
35	140062	Cap Plunger

NOTE: All component dimensions given in U.S. inches.
1 inch = 25.4 mm

REPAIR PARTS

8 HP 21" TILLER - - MODEL NUMBER 917.299881

MAINFRAME, RIGHT SIDE

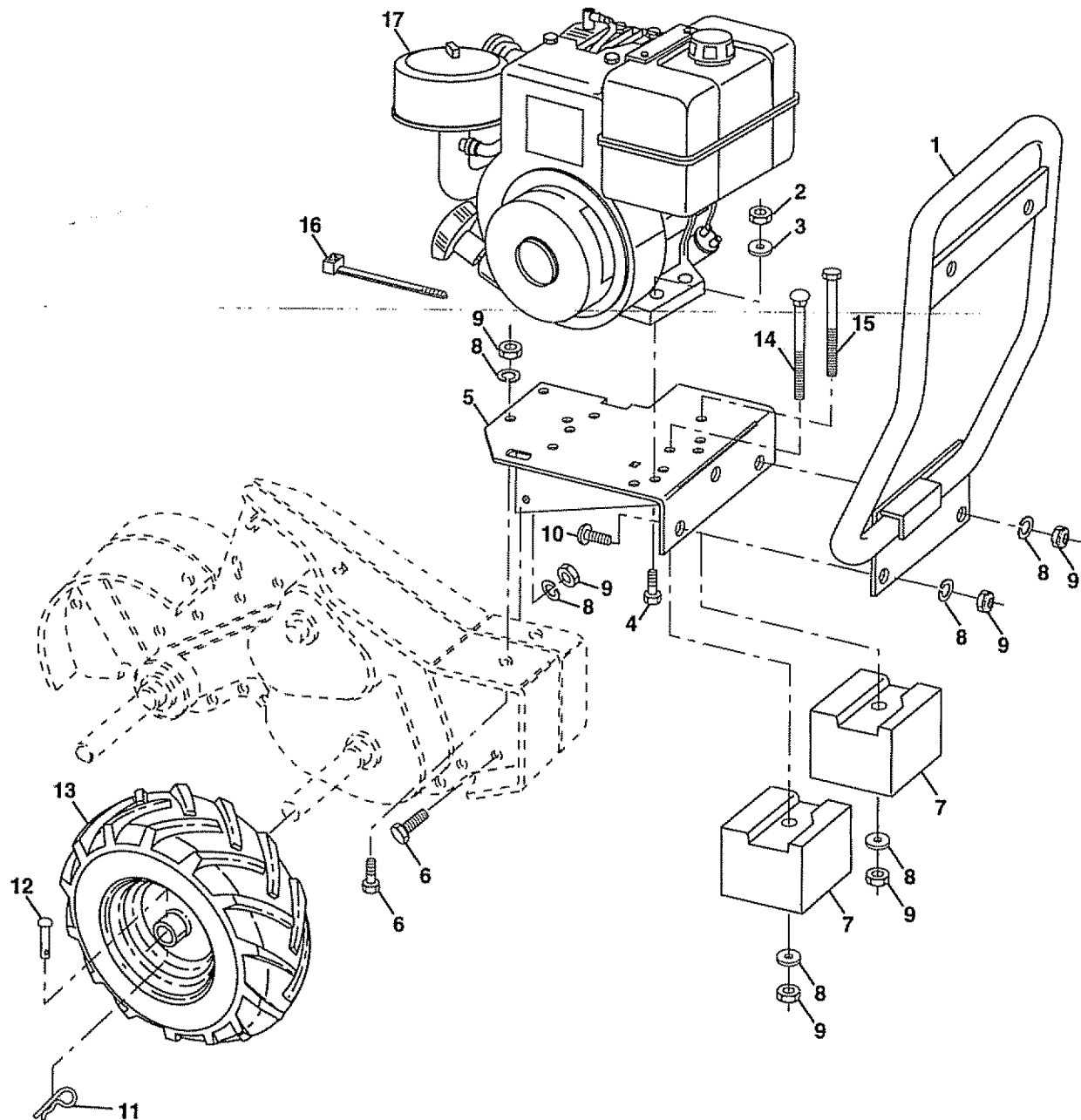

KEY NO.	PART NO.	DESCRIPTION
1	138402	Bumper
2	73220500	Nut Fin Hex 5/16-18
3	10040500	Wash Lock Hvy Hlcl 5/16
4	74760528	Bolt, Hex 5/16-18 x 1-3/4
5	138669	Bracket, Engine
6	STD523710	Bolt, Hex Head 3/8-16 x 1
7	8450J	Counter Weight, R.H.
8	STD551137	Washer, Lock 3/8
9	STD541037	Nut, Hex 3/8-16
10	STD533710	Bolt, Carriage 3/8-16 x 1
11	STD624003	Clip, Hairpin

KEY NO.	PART NO.	DESCRIPTION
12	4929H	Rivet, Drilled
13	5015J	Tire
	138417	Rim
	795R	Tire Valve
14	72470636	Bolt, Carriage 3/8-16 x 4-1/2
15	STD523745	Bolt, Hex Head 3/8-16 x 4-1/2
16	104164X	Tie, Cable
17	138401	Engine, Briggs & Stratton, 8 HP, Model Number 190402, Type Number 6151-01

NOTE: All component dimensions given in U.S.inches.
1 inch = 25.4 mm

REPAIR PARTS

8 HP 21" TILLER -- MODEL NUMBER 917.299881

TRANSMISSION

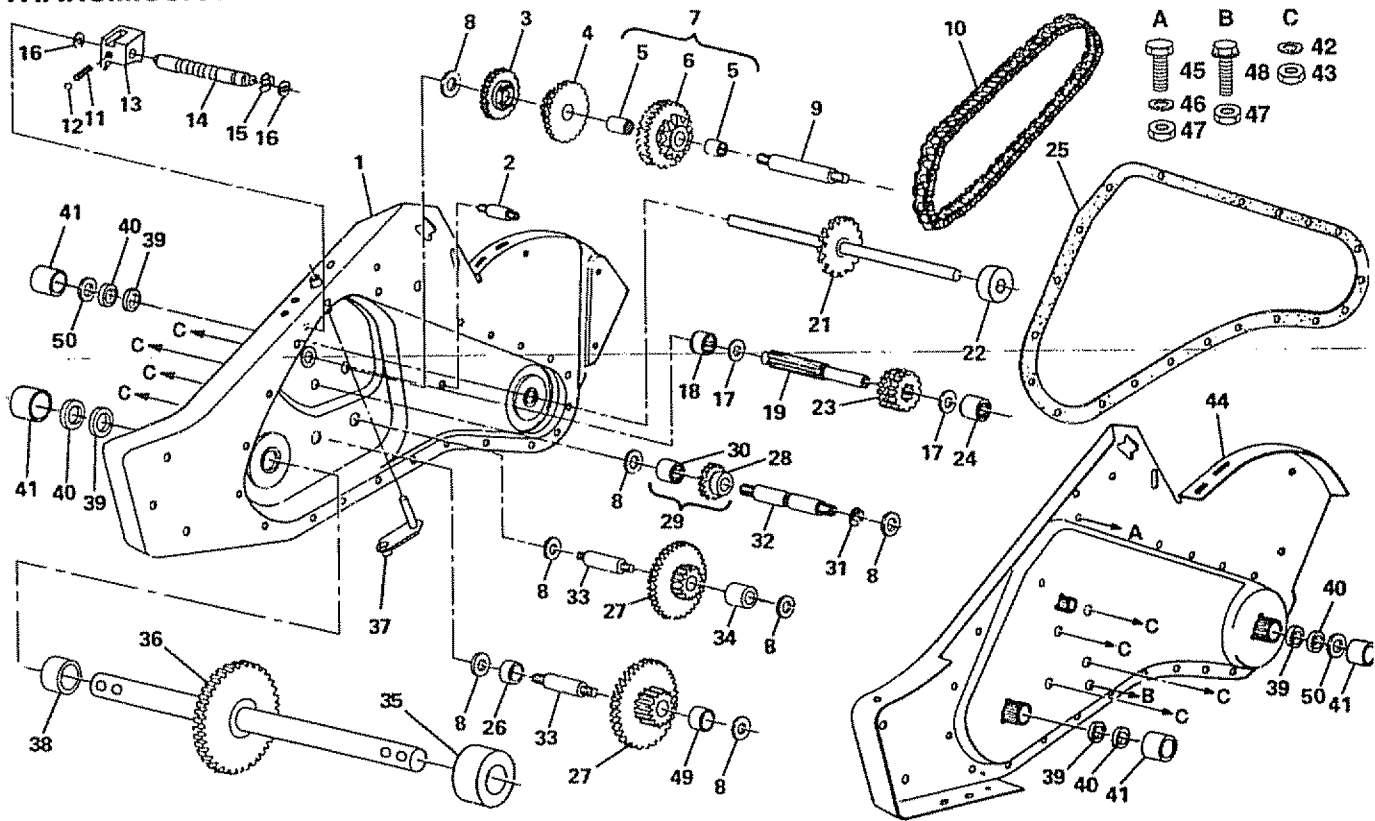

KEY NO.	PART NO.	DESCRIPTION	KEY NO.	PART NO.	DESCRIPTION
--	142477	Transmission Assembly	28	8357J	Gear, Reverse Idler
1	106179X	Gearcase Assembly, R.H., with Bearing (Includes Key No. 18)	29	674A289	Gear Assembly, Reverse Idler (Includes Key Numbers 28 and 30)
2	8370J	Bolt, Upset	30	6803J	Bearing, Needle
3	8547J	Gear, Reverse	31	12000040	Klip Ring
4	8546J	Gear, Cluster, Red., 1st and 2nd	32	8356J	Shaft, Reverse Idler
5	100413K	Bearing, Needle	33	100016K	Shaft, Reduction, 2nd
6	674A291	Sprocket Assembly, Tine	34	106392X	Spacer .765 I.D. x 1-1/8 x 1-3/8
7	674A290	Sprocket Assembly with Bearings (Includes Key #6 & two of Key #5)	35	106394X	Spacer, Ground Drive, L.H.
8	4358J	Washer	36	100436L	Shaft Assembly, Ground
9	8358J	Shaft, Reduction, 1st	37	142145	Assembly, Shift Bracket
10	8371J	Chain, Roller, 60P	38	106393X	Spacer, Ground Drive, R.H.
11	100371K	Spring, Shift, Fork	39	7393R	Seal, Oil
12	7392M	Ball, Steel	40	140576	Seal, Ring, Rubber
13	8353J	Fork, Shift	41	9672R	Cup, Formed
14	8354J	Shaft, Shift	42	STD551143	Washer, Lock 7/16
15	12000039	Klip Ring	43	STD541143	Nut, Hex 7/16-20
16	4360J	Washer, Seal	44	109331X	Gearcase Assembly, L.H., with Bearing (Includes Key Number 24)
17	1370H	Race, Bearing, Thrust, 5/8 I.D.	45	74780512	Bolt, Hex Head 5/16-18 x 3/4
18	4895H	Bearing, Needle	46	STD551131	Washer, Lock 5/16
19	100724M	Shaft, Input	47	STD541031	Nut, Hex Head 5/16-18
21	105378X	Shaft Assembly, Tine	48	100107K	Screw, Whiz-Lock 5/16-18 x 4
22	106181X	Spacer 1.008 x 1-3/4 x .645	49	106391X	Spacer .765 I.D. x 1.12 x 3/4
23	8359J	Pinion, Input	50	102144X	Ring Retainer Spiral
24	5020J	Bearing, Needle	--	6066J	Grease, Plastilub Number 1
25	8372J	Gasket, Gearcase			
26	106389X	Spacer .765 I.D. x 1.12 x 5/8			
27	100433M	Gear, Cluster, Red., 2nd and 3rd			

NOTE: All component dimensions given in U.S. inches
1 inch = 25.4 mm

REPAIR PARTS

8 HP 21" TILLER -- MODEL NUMBER 917.299881

TINE SHIELD

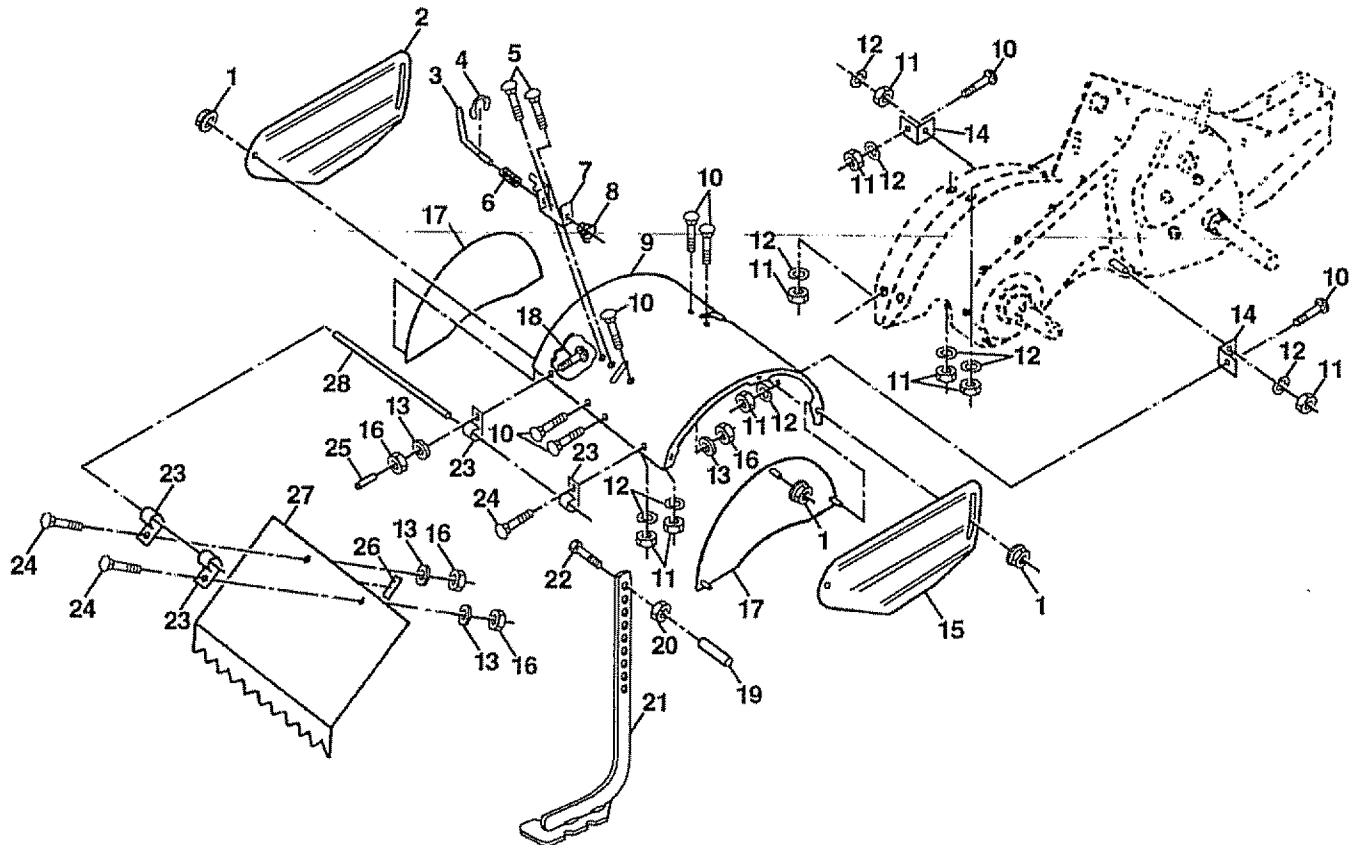

KEY NO.	PART NO.	DESCRIPTION	KEY NO.	PART NO.	DESCRIPTION
1	98000129	Nut, Flange 5/16-18	16	73220400	Nut Fin Hx 1/4-20
2	108711X459	Shield, Side, Outer, L.H.	17	104084X459	Shield, Side
3	8393J	Pin, Depth Stake	18	STD532512	Bolt, Carriage 1/4-20 x 1-1/4 Gr. 5
4	12000036	Ring, Klip	19	8389J	Grip
5	72140508	Bolt, Carriage 5/16-18 x 1	20	STD541037	Nut, Hex 3/8-16
6	8394J	Spring	21	138420	Stake, Depth
7	8392J	Bracket, Latch	22	74930656	Bolt, Hex 3/8-16 x 2-1/2
8	109230X	Spring, Depth Stake	23	4440J	Hinge
9	104178X459	Shield, Tine	24	72140408	Bolt, Carriage 1/4-20 x 1/2 Gr. 5
10	STD533107	Bolt, Carriage 5/16-18 x 3/4 Gr. 5	25	6712J	Cap, Vinyl
11	STD541031	Nut, Hex 5/16-18	26	109227X	Pad, Idler
12	STD551131	Washer, Lock 5/16	27	102713X459	Shield, Leveling
13	10040400	Washer Lock Hvy Helical 1/4	28	138609	Pin, Hinge
14	8386J	Bracket, Shield Tine			
15	108710X459	Shield, Side, Outer R.H.			

NOTE: All component dimensions given in U.S. inches.
1 inch = 25.4 mm

REPAIR PARTS

8 HP 21" TILLER - - MODEL NUMBER 917.299881

TINE ASSEMBLY

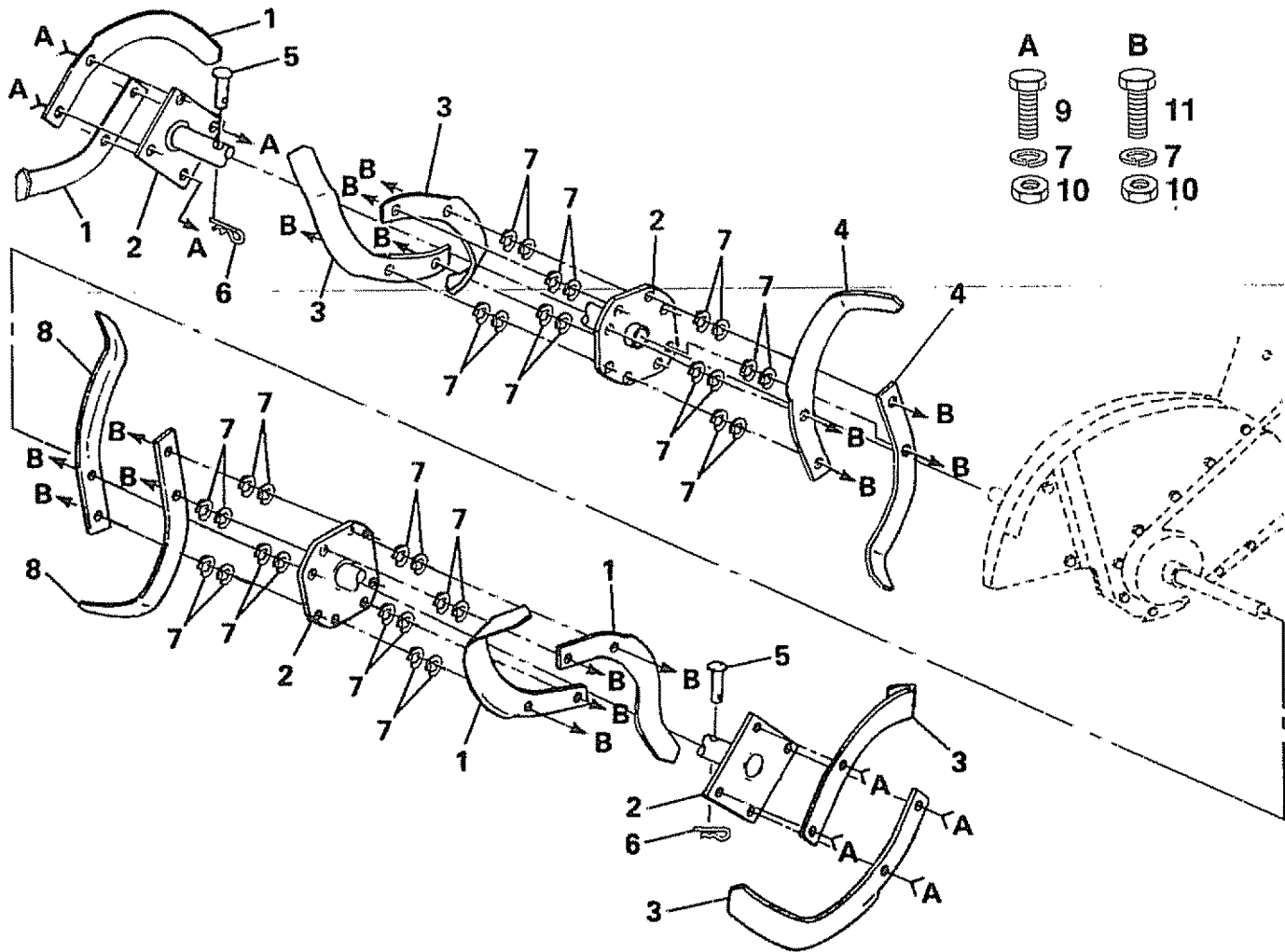

KEY NO.	PART NO.	DESCRIPTION
1	6556J	Tine, L.H., 14"
2	100445L	Hub Assembly
3	6557J	Tine, R.H., 14"
4	101194M	Tine, L.H., 14"
5	4929H	Pin, Clevis
6	3146R	Clip, Hairpin
7	STD551137	Washer, Lock 3/8
8	101193M	Tine, R.H., 14"
9	74610616	Bolt, Hex Head 3/8-24 x 1
10	73610600	Nut, Hex 3/8-24
11	STD623715	Bolt, Hex Head 3/8-24 x 1-1/2

NOTE: All component dimensions given in U.S. inches.
1 inch = 25.4 mm

REPAIR PARTS

8 HP 21" TILLER - - MODEL NUMBER 917.299881

DECALS

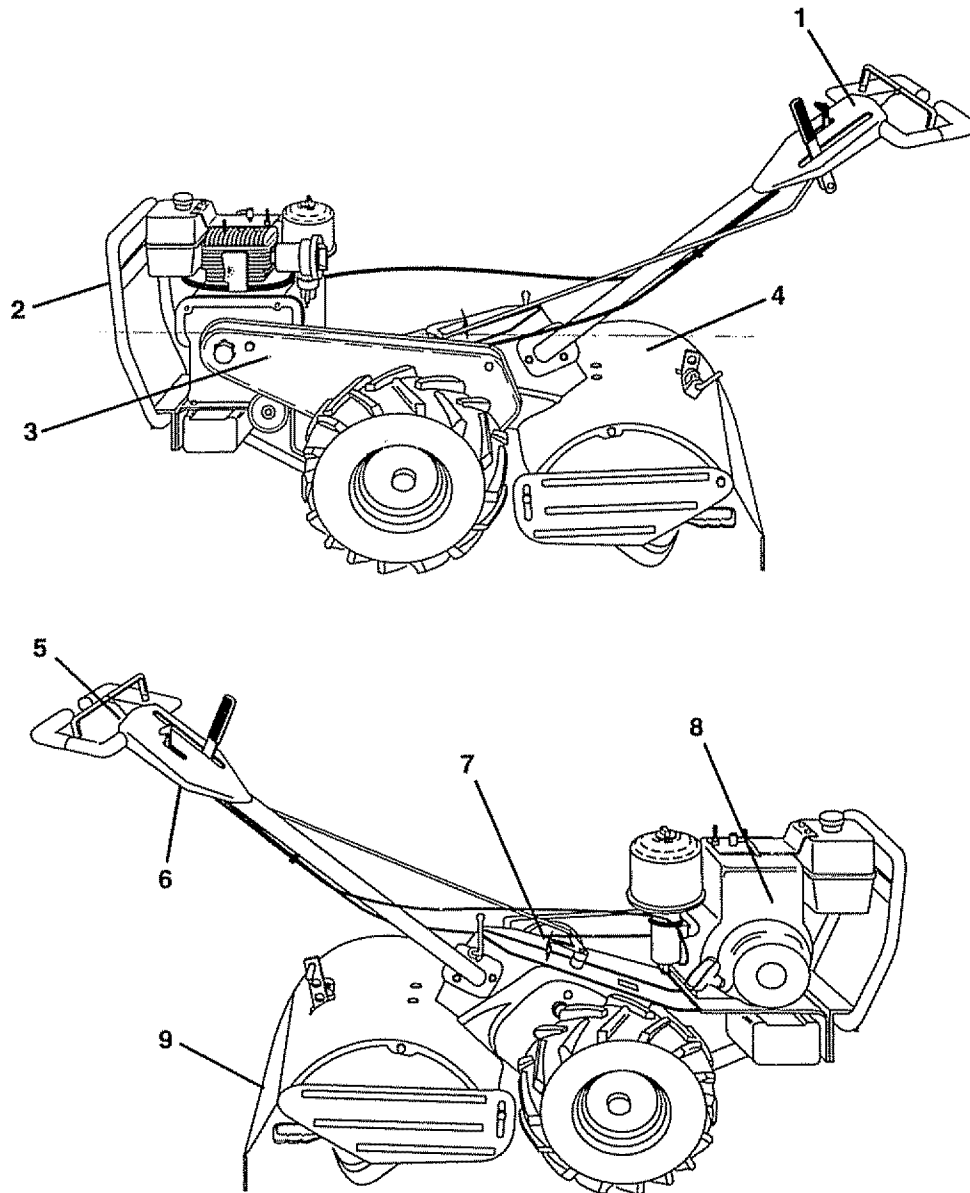

KEY NO.	PART NO.	DESCRIPTION
1	144971	Decal, Logo
2	138813	Decal, Logo
3	138263	Decal, Logo
4	138286	Decal, Logo
5	137538	Decal, Caution, Drive Control
6	120431X	Decal, Hand Placement
7	138546	Decal, Shift Indicator
8	272698	Decal, Engine, HP
9	120075X	Decal, Warning, Rotating Tines
--	144980	Manual, Owner's, English
--	144981	Manual, Owner's, Spanish

REPAIR PARTS

8 HP 21" TILLER -- MODEL NUMBER 917.299881

ENGINE, BRIGGS & STRATTON -- MODEL NUMBER 190402, TYPE NO.6151-01

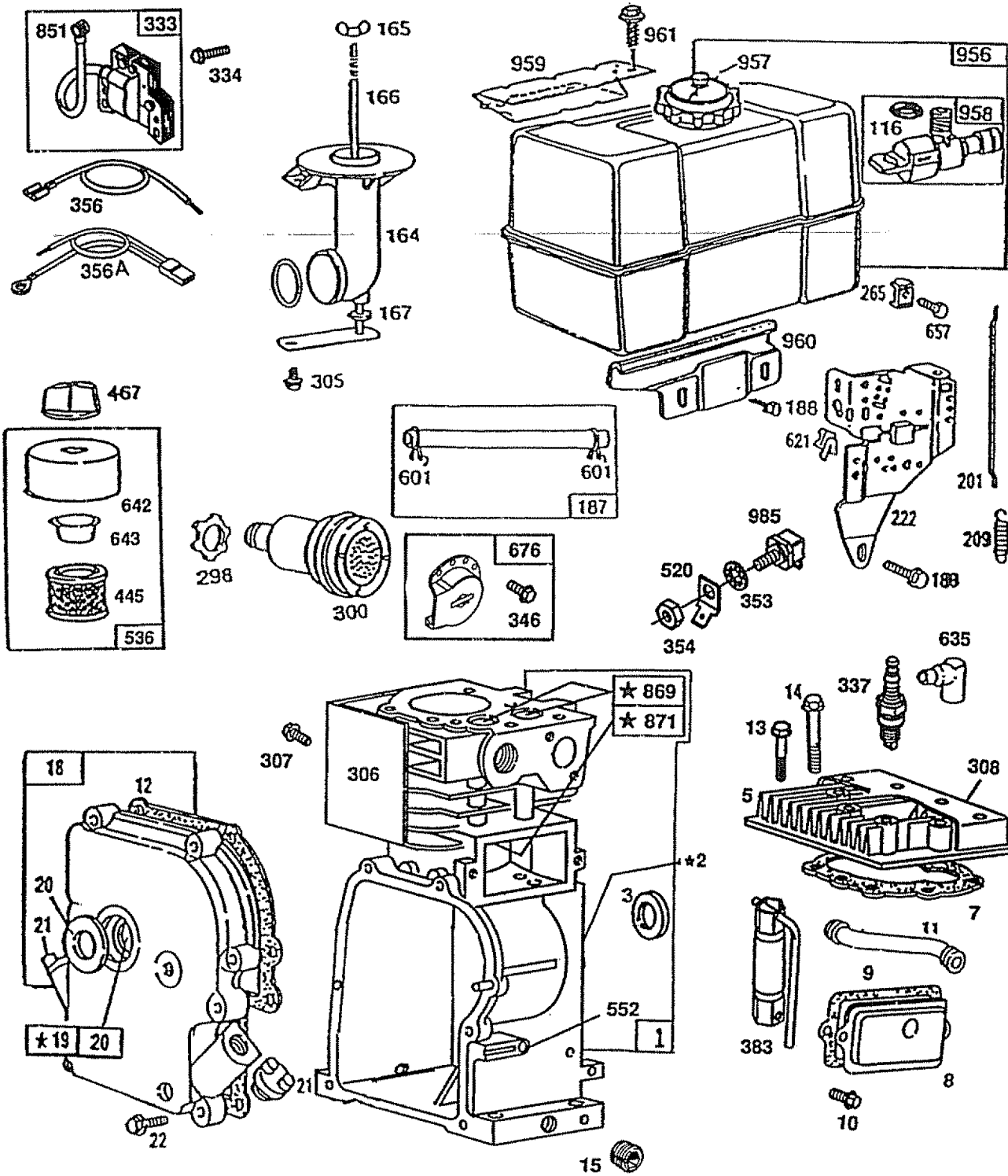

1019 LABEL KIT

358 GASKET SET

★ REQUIRES SPECIAL TOOLS TO INSTALL.
SEE REPAIR INSTRUCTION MANUAL.

REPAIR PARTS

8 HP 21" TILLER - - MODEL NUMBER 917.299881

ENGINE, BRIGGS & STRATTON - - MODEL NUMBER 190402, TYPE NO.6151-01

KEY PART NO.	NO.	DESCRIPTION	KEY PART NO.	NO.	DESCRIPTION
1	495631	Cylinder Assembly	41	292260	Rotocoil, Exhaust Valve
2	495657	Bushing, Cylinder	42	93630	Retainer, Exhaust Valve Rotocoil(2)
3	391086	* Seal, Oil	45	260933	Tappet, Valve
5	214015	Head, Cylinder	46	211689	Gear, Cam
7	272163	* Gasket, Cylinder Head	50	212488	Elbow, Intake
8	390321	Breather Assembly	51	270684	* Gasket, Carburetor Mounting
9	27803	* Gasket, Valve Cover	52	27828	* Gasket, Intake Elbow Mounting
10	94621	Screw, Sems	53	93956	Screw, Shoulder
11	280267	Tube, Breather	53A	93357	Screw, Sems, Carburetor Mounting
12	271701	* Gasket, Crankcase Cover 1/64"	54	93208	Screw, Intake Elbow
	27876	* Gasket, Crankcase Cover .005"	55	393576	Housing, Rewind Starter
	27877	* Gasket, Crankcase Cover .009"	56	295871	Pulley, Rewind Starter
13	94565	Screw, Cylinder Head 3-9/16"	57	490179	Spring, Rewind Starter
14	93723	Screw, Cylinder Head 3"	58	66884	Rope, Rewind Starter
15	94720	Plug, Oil Drain, Flush	59	490653	Insert, Starter Handle
	94239	Plug, Oil Drain, Square Head	60	490652	Handle, Rewind Starter
16	495648	Crankshaft	63	260414	Spring, Ratchet
	94388	Key, Timing Gear Retaining Device	64	230543	Adapter, Ratchet Spring
18	392818	Cover Assembly, Crankcase	65	94128	Screw, Rewind Starter Housing Mounting
19	295964	Bushing, Crankcase	66	399671	Clutch Assembly, Rewind Starter
20	391086	* Seal, Oil	67	394897	Housing, Rewind Starter Clutch
21	66768	Plug, Oil Filler	68	63770	Ball, Clutch
22	93585	Screw, Crankcase Cover	70	298799	Ratchet, Rewind Starter Clutch
23	298260	Flywheel, Magneto	71	394506	Washer, Clutch Retaining
24	222698	Key, Flywheel	73	221796	Screen, Rewind Starter
25	391673	Piston Assembly, Standard Size	74	93758	Screw, Sems
	391674	Piston Assembly .010" Oversize	75	224061	Washer, Spring
	391675	Piston Assembly .020" Oversize	90	390323	Carburetor Assembly, Manual Choke
	391676	Piston Assembly .030" Oversize	91	399443	Body Assembly, Upper Carburetor
26	391669	Ring Set, Piston, Standard Size	93	23108	Bushing, Throttle Shaft
	299743	Ring Set, Piston, Chrome, Std. Size	94	292681	** Valve Assembly, Carburetor Idle
	391670	Ring Set, Piston .010" Oversize	95	93499	Screw, Sems, Throttle and Choke Valve Mounting
	391671	Ring Set, Piston .020" Oversize	96	223370	Valve, Throttle
	391672	Ring Set, Piston .030" Oversize	97	298826	Shaft and Lever, Throttle
27	68546	Lock, Piston Pin	98	91920	Screw, Fillister Head
28	295840	Pin Assy., Piston, Standard Size	99	26157	Spring, Throttle Adjusting
	295841	Pin Assy., Piston .005" Oversize	100	212904	Stop, Throttle
29	390401	Rod Assembly, Connecting	101	93043	Pin, Throttle Stop
	390773	Rod Assembly, Connecting, .020" Undersize Crankpin Bore	102	27918	** Gasket, Carburetor Body
30	222113	Dipper, Connecting Rod			
32	92659	Screw, Connecting Rod			
33	390419	Valve, Exhaust			
34	94670	Valve, Intake			
35	65906	Spring, Intake Valve			
36	26828	Spring, Exhaust Valve			
37	222475	Guard, Flywheel			
38	93777	Screw, Sems			
40	221596	Retainer, Intake Valve			

* Included in Gasket Set, Part Number 299577

** Included in Carburetor Overhaul Kit, Part #398235

NOTE: All component dimensions given in U.S. inches
1 inch = 25.4 mm

REPAIR PARTS

8 HP 21" TILLER - - MODEL NUMBER 917.299881

ENGINE, BRIGGS & STRATTON - - MODEL NUMBER 190402, TYPE NO. 6151-01

KEY PART NO. NO.	DESCRIPTION	KEY PART NO. NO.	DESCRIPTION
103 99333	Float, Carburetor	354 90576	Nut, Hex
104 230896	** Pin, Float Hinge	356 398838	Wire, Ground
105 394681	** Valve, Fuel Inlet	356A 398808	Wire, Ground
107 399442	Body Assembly, Lower Carburetor	358 299577	Gasket Set
108 62872	Valve, Choke	363 19203	Puller, Flywheel
109 391987	Shaft and Lever, Choke	373 92987	Nut, Hex
110 222712	Washer, Choke Lever	383 89838	Wrench, Spark Plug
111 26155	Spring, Choke Lever	445 393957	Cartridge, Air Cleaner
112 23123	Screw, Choke Lever	467 493903	Knob, Air Cleaner
113 398202	** Nozzle, Carburetor	520 93722	Terminal, Spade
114 68667	** Gasket, Nozzle	536 391063	Air Cleaner Assembly
116 280203	O-Ring, Fuel Valve	552 491893	Bushing, Governor Crank
118 99525	** Valve, Needle	562 92613	Bolt, Governor Lever
Includes:	22235 Washer, Brass	592 231082	Nut, Hex
	26336 Spring	601 93053	Clamp, Fuel Pipe
	65978 O-Ring	608 390391	Starter Assembly, Rewind
	394033 Valve, Needle	614 93306	Cotter Pin
119 94152	Screw, Sems, Hex Head	615 93307	Retainer, E-Ring
121 398235	Carburetor Overhaul Kit	616 231057	Crank, Governor
164 398592	Pipe Assembly, Air Cleaner	621 396847	Switch, Stop
Uses:	271265 O-Ring	635 66538	Elbow, Spark Plug
165 94289	Nut, Wing	642 222271	Cover, Air Cleaner
166 392105	Stud, Air Cleaner	643 222272	Cup, Air Cleaner
167 65978	Seal, Air Cleaner Stud	655 222598	Anchor, Spring
186 67218	Connector, Fuel Pipe	657 93496	Screw, Sems
187 296004	Pipe, Fuel	676 393757	Deflector, Exhaust
188 93535	Screw, Sems	741 262479	Gear, Timing
200 221760	Guide, Air	843 280149	Sleeve, Choke Lever
201 260872	Link, Governor	851 221798	Terminal, Ignition Cable
209 261126	Spring, Governor	869 211661	Seat, Intake and Exhaust Valves
219 494845	Gear Governor	871 231218	Guide, Intake and Exhaust Valves
220 221551	Washer, Thrust	956 493337	Fuel Tank Assembly
222 399151	Plate, Governor Control	957 493988	Cap, Fuel Tank
227 391965	Lever Assembly, Governor	958 399517	Valve Assembly, Fuel Shut-Off
230 94742	Washer, Governor Crank	959 223462	Bracket, Fuel Tank, Upper
265 221535	Clamp, Casing	960 492990	Bracket, Fuel Tank, Lower
298 261409	Locknut, Muffler	961 94095	Screw, Tank Mounting
300 393010	Muffler, Exhaust	985 398525	Insulator Assembly
304 491596	Housing, Blower	1016 490817	Spacer
305 94608	Screw, Sems	1019 491181	Label Kit
306 223374	Shield, Cylinder		
307 93949	Screw, Cylinder Shield		
308 222636	Cover, Cylinder Head		
332 92284	Nut		
333 398811	Armature, Magneto		
334 93381	Screw, Armature Mounting		
337 802592	Spark Plug		
346 93705	Screw, Sems		
353 92791	Washer, Lock		

RPM Settings: Low: 1750-1950, High: 3400-3600

* Included in Gasket Set, Part Number 299577

** Included in Carburetor Overhaul Kit, Part #398235

NOTE: All component dimensions given in U.S. inches
1 inch = 25.4 mm

SERVICE NOTES

SERVICE NOTES

SERVICE NOTES

SEARS
OWNER'S
MANUAL

MODEL NO.
917.299881

**IF YOU NEED
REPAIR SERVICE
OR PARTS:**

FOR REPAIR SERVICE, CALL
THIS TOLL FREE NUMBER:

1-800-4-REPAIR
(1-800-473-7247)

FOR REPLACEMENT PARTS
INFORMATION AND
ORDERING, CALL THIS
TOLL FREE NUMBER:

1-800-FON-PART
(1-800-366-7278)

CRAFTSMAN®
8.0 HP
21 INCH TINE WIDTH
REAR TINE TILLER WITH
COUNTER ROTATING TINES

Each tiller has its own model number. Each engine has its own model number.

The model number for your tiller will be found on a plate attached to the top of the transmission.

The model number for your engine will be found on the blower housing of the engine.

All parts listed herein may be ordered from any Sears, Roebuck and Co. Service Center/Department and most Retail Stores.

WHEN ORDERING REPAIR PARTS, ALWAYS GIVE THE FOLLOWING INFORMATION:

- **PRODUCT - REAR TINE TILLER**
- **MODEL NUMBER - 917.299881**
- **ENGINE MODEL NUMBER - 190402, TYPE NUMBER 6151-01**
- **PART NUMBER**
- **PART DESCRIPTION**

Your Sears merchandise has added value when you consider Sears has service units nationwide staffed with Sears trained technicians... professional technicians specifically trained to insure that we meet our pledge to you, we service what we sell.

Sears, Roebuck and Co., Hoffman Estates, IL 60179 U.S.A.