

Operator's Manual

CRAFTSMAN®

10 IN. JOBSITE TABLE SAW

Model No. 137.284630

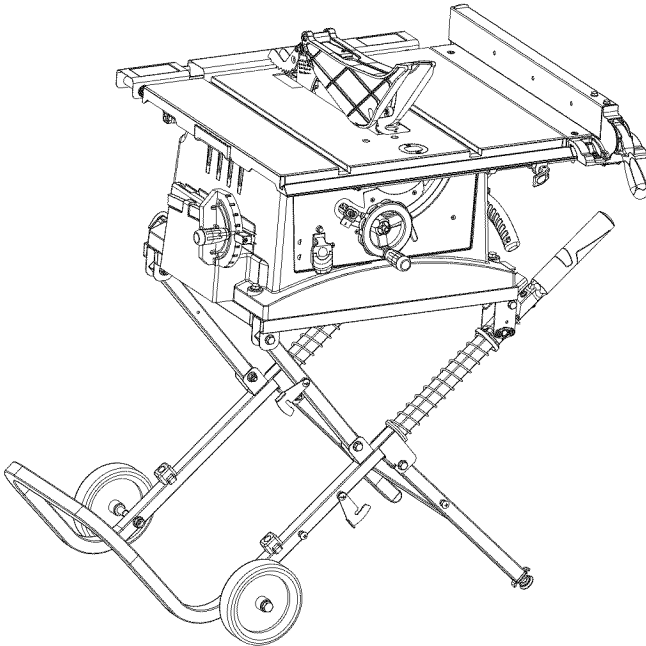

CAUTION:

Before using this Table Saw, read this manual and follow all its Safety Rules and Operating Instructions

- Safety Instructions
- Installation
- Operation
- Maintenance
- Parts List

**Customer Help Line
For Technical Support
1-800-843-1682**

**Sears Parts &
Repair Center
1-800-488-1222**

Sears Brands Management Corporation Hoffman Estates, IL 60179 USA

See the full line of Craftsman® products at craftsman.com

Click on the Craftsman Club® link and join today!

Part No. 137284630001

Printed in China

TABLE OF CONTENTS

SECTION	PAGE
Warranty	2
Product Specifications	3
Symbols.....	4
Power Tool Safety	5
Table Saw Safety	8
Electrical Requirements and Safety	11
Accessories and Attachments	13
Tools Needed for Assembly	13
Carton Contents	14
Know Your Table Saw	16
Glossary of Terms	17
Assembly and Adjustments.....	19
Operation	33
Maintenance	42
Troubleshooting Guide	44
Parts List	47
Repair Protection Agreements	51

WARRANTY

CRAFTSMAN FULL WARRANTY

If this Craftsman product fails due to a manufacturer's defect in material or workmanship with one year from the date of purchase, return it to any Sears store, Sears Parts & Repair Service Center, or other Craftsman outlet in the United States for free repair (or replacement if repair proves impossible). This warranty does not include expendable parts such as saw blades which can wear out from normal use within the warranty period. This warranty applies for only 90 days from the date of purchase if this product is ever used for commercial or rental purposes. This warranty gives you special legal rights, and you may also have other rights which vary from state to state.

Sears, Roebuck and Co., Hoffman Estates, IL 60179

WARNING

Some dust created by power sanding, sawing, grinding, drilling and other construction activities contains chemicals known to the state of California to cause cancer, birth defects or other reproductive harm. Some examples of these chemicals are:

- Lead from lead-based paints,
- Crystalline silica from bricks and cement and other masonry products, and
- Arsenic and chromium from chemically-treated lumber.

Your risk from these exposures varies, depending on how often you do this type of work. To reduce your exposure to these chemicals: work in a well ventilated area, and work with approved safety equipment, such as those dust masks that are specially designed to filter out microscopic particles. Avoid prolonged contact with dust from power sanding, sawing, grinding, drilling, and other construction activities. Wear protective clothing and wash exposed areas with soap and water. Allowing dust to get into your mouth, eyes, or lay on the skin may promote absorption of harmful chemicals.

PRODUCT SPECIFICATIONS

MOTOR

Type.....	Universal
Amperes.....	15 Amp
Voltage.....	120 V AC
Hz.....	60 Hz
RPM (no load)	5000 RPM (No load)
Overload Protection.....	Yes

BLADE SIZE

Diameter.....	10 in.
Arbor Size.....	5/8 in.

SAW

Rip Fence.....	Yes
Miter Gauge.....	Yes
Rip Capacity	8 in. Left 24 in. Right
Maximum Cut Depth @ 90°	3 in.
Maximum Cut Depth @ 45°	2-1/2 in.
Maximum Diameter Dado	6 in. (Stackable only)
Maximum Dado Cut Width	1/2 in.

WARNING

To avoid electrical hazards, fire hazards or damage to the tool, use proper circuit protection.

This tool is wired at the factory for 110-120 Volt operation. It must be connected to a 110-120 Volt / 15 Ampere time delay fuse or circuit breaker. To avoid shock or fire, replace power cord immediately if it is worn, cut or damaged in any way.

Before using your tool, it is critical that you read and understand these safety rules. Failure to follow these rules could result in serious injury to you or damage to the tool.

SYMBOLS

WARNING ICONS

Your power tool and its Operator's Manual may contain "WARNING ICONS" (a picture symbol intended to alert you to, and/or instruct you how to avoid, a potentially hazardous condition). Understanding and heeding these symbols will help you operate your tool better and safer. Shown below are some of the symbols you may see.



SAFETY ALERT: Precautions that involve your safety.



PROHIBITION



WEAR EYE PROTECTION: Always wear safety goggles or safety glasses with side shields.



WEAR RESPIRATORY AND HEARING PROTECTION: Always wear respiratory and hearing protection.



READ AND UNDERSTAND OPERATOR'S MANUAL: To reduce the risk of injury, user and all bystanders must read and understand operator's manual before using this product.



KEEP HANDS AWAY FROM BLADE: Failure to keep your hands away from the blade will result in serious personal injury.



SUPPORT AND CLAMP WORK



DANGER: Indicates an imminently hazardous situation which, if not avoided, will result in death or serious injury.



WARNING: Indicates a potentially hazardous situation which, if not avoided, could result in death or serious injury.



CAUTION: Indicates a potentially hazardous situation which, if not avoided, may result in minor or moderate injury.



CAUTION: Used without the safety alert symbol indicates a potentially hazardous situation which, if not avoided, may result in property damage.

POWER TOOL SAFETY



GENERAL SAFETY INSTRUCTIONS BEFORE USING THIS POWER TOOL

Safety is a combination of common sense, staying alert and knowing how to use your power tool.

WARNING

To avoid mistakes that could cause serious injury, do not plug the tool in until you have read and understood the following.

-  **1. READ** and become familiar with the entire Operator's Manual. **LEARN** the tool's application, limitations and possible hazards.
- 2. KEEP GUARDS IN PLACE** and in working order.
- 3. REMOVE ADJUSTING KEYS AND WRENCHES.** Form the habit of checking to see that keys and adjusting wrenches are removed from the tool before turning ON.
- 4. KEEP WORK AREA CLEAN.** Cluttered areas and benches invite accidents.
- 5. DO NOT USE IN DANGEROUS ENVIRONMENTS.** Do not use power tools in damp locations, or expose them to rain or snow. Keep work area well lit.
- 6. KEEP CHILDREN AWAY.** All visitors and bystanders should be kept a safe distance from work area.
- 7. MAKE WORKSHOP CHILD PROOF** with padlocks, master switches or by removing starter keys.
- 8. DO NOT FORCE THE TOOL.** It will do the job better and safer at the rate for which it was designed.
- 9. USE THE RIGHT TOOL.** Do not force the tool or an attachment to do a job for which it was not designed.
- 10. USE PROPER EXTENSION CORDS.** Make sure your extension cord is in good condition. When using an extension cord, be sure to use one heavy enough to carry the current your product will draw. An undersized cord will result in a drop in line voltage and in loss of power which will cause the tool to overheat. The table on page 12 shows the correct size to use depending on cord length and nameplate ampere rating. If in doubt, use the next heavier gauge. The smaller the gauge number, the heavier the cord.
- 11. WEAR PROPER APPAREL.** Do not wear loose clothing, gloves, neckties, rings, bracelets or other jewelry which may get caught in moving parts. Nonslip footwear is recommended. Wear protective hair covering to contain long hair.

12.  **ALWAYS WEAR EYE PROTECTION.** Any power tool could throw foreign objects into the eyes and cause permanent eye damage. **ALWAYS** wear Safety Goggles (not glasses) that comply with ANSI Safety standard Z87.1. Everyday eyeglasses have only impact-resistant lenses. They **ARE NOT** safety glasses. Safety Goggles are available at Sears. **NOTE:** Glasses or goggles not in compliance with ANSI Z87.1 could cause serious injury when they break.
13.  **WEAR A FACE MASK OR DUST MASK.** Sawing operation produces dust.
14.  **SECURE THE WORKPIECE.** Use clamps or a vise to hold workpiece when practical. It is safer than using your hand and also it frees both hands to operate the tool.
15. **DISCONNECT TOOLS FROM POWER SOURCE** before servicing, and when changing accessories such as blades, bits and cutters.
16. **REDUCE THE RISK OF UNINTENTIONAL STARTING.** Make sure switch is in the OFF position before plugging the tool in.
17. **USE RECOMMENDED ACCESSORIES.** Consult this Operator's Manual for recommended accessories. The use of improper accessories may cause risk of injury to yourself or others.
18. **NEVER STAND ON THE TOOL.** Serious injury could occur if the tool is tipped or if the cutting tool is unintentionally contacted.
19. **CHECK FOR DAMAGED PARTS.** Before further use of the tool, a guard or other part that is damaged should be carefully checked to determine that it will operate properly and perform its intended function – check for alignment of moving parts, binding of moving parts, breakage of parts, mounting and any other conditions that may affect its operation. A guard or other part that is damaged should be properly repaired or replaced.
20. **NEVER LEAVE THE TOOL RUNNING UNATTENDED. TURN THE POWER "OFF".** Do not walk away from a running tool until the blade complete stop and the tool is unplugged from the power source.
21. **DO NOT OVERREACH.** Keep proper footing and balance at all times.

22. **MAINTAIN TOOLS WITH CARE.**

Keep tools sharp and clean for best and safest performance. Follow instructions for lubricating and changing accessories.

23. **DO NOT** use power tool in presence of flammable liquids or gases.

24. **DO NOT** operate the tool if you are under the influence of any drugs, alcohol or medication that could affect your ability to use the tool properly.

25. Dust generated from certain materials can be hazardous to your health. Always operate saw in well-ventilated area and provide for proper dust removal.

26.  **WEAR HEARING PROTECTION** to reduce the risk of induced hearing loss.

TABLE SAW SAFETY

- 1. ALWAYS USE SAW BLADE GUARD**, riving knife and anti-kickback pawls for every through-sawing operation. Through-sawing operations are those in which the blade cuts completely through the workpiece when ripping or crosscutting. Always be sure blade guard is tightened securely.
- 2. ALWAYS HOLD WORKPIECE FIRMLY** against the miter gauge or rip fence.
- 3. ALWAYS USE** a push stick or push block, especially when ripping narrow stock. Refer to ripping instructions in this Operator's Manual where the push stick is covered in detail. A pattern for making your own push stick is included on page 46.
- 4. NEVER PERFORM ANY OPERATION FREEHAND**, which means can using hands to support the workpiece, but always use either the fence **OR** the miter gauge to position and guide the workpiece.
- 5. NEVER STAND** or have any part of your body in line with the path of the saw blade. Keep your hands out of the saw blade path.
- 6. NEVER REACH** behind or over the cutting tool for any reason.
- 7. REMOVE** the rip fence when crosscutting.
- 8. DO NOT USE** a molding head with this saw.
- 9. FEED WORKPIECE INTO THE BLADE** against the direction of rotation only.
- 10. NEVER** use the rip fence as a cut-off gauge when crosscutting.
- 11. NEVER ATTEMPT TO FREE A STALLED SAW BLADE** without first turning the saw OFF. Turn power switch OFF immediately to prevent motor damage.
- 12. PROVIDE ADEQUATE SUPPORT** to the rear and the sides of the saw table for long or wide workpieces.
- 13. AVOID KICKBACKS** (work thrown back towards you) by keeping the blade sharp, the rip fence parallel to the saw blade and by keeping the riving knife, anti-kickback pawls and guards in place, aligned and functioning. Do not release work before passing it completely beyond the saw blade. Do not rip work that is twisted, warped or does not have a straight edge to guide it along the fence. Do not attempt to reverse out of a cut with the blade running.

DANGER

FREEHAND CUTTING IS THE MAJOR CAUSE OF KICKBACK AND FINGER/HAND AMPUTATIONS. NEVER USE THE MITER GAUGE AND FENCE SIMULTANEOUSLY.

14. **AVOID AWKWARD OPERATIONS** and hand positions where a sudden slip could cause your hand to move into the saw blade.

15. **NEVER USE SOLVENTS** to clean plastic parts. Solvents could possibly dissolve or otherwise damage the material. Only a soft damp cloth should be used to clean plastic parts.

16. **MOUNT** your table saw on a bench or stand before performing any cutting operations. Refer to **ASSEMBLY** on page 19.

17.  **WARNING**
Never cut metals or masonry products with this tool. This table saw is designed for use on wood and wood-like products only.

18. **ALWAYS USE IN A WELL-VENTILATED AREA.** Remove sawdust frequently. Clean out sawdust from the interior of the saw to prevent a potential fire hazard.

19. **NEVER LEAVE THE SAW RUNNING UNATTENDED.** Do not leave the saw until the blade comes to a complete stop.

20. For proper operation follow the instructions in this Instruction Manual entitled **ASSEMBLY AND ADJUSTMENTS** (Page 19). Failure to provide sawdust fall-through and removal hole will allow sawdust to build up in the motor area resulting in a fire hazard and potential motor damage.

21. **USE ONLY** saw blades recommended with the warning that the riving knife shall not be thicker than the width of the groove cut by the saw blade and not thinner than the body of the saw blade.

22. **USE PUSH-STICK OR PUSH BLOCK** to feed the workpiece past the saw blade. The push-stick or push block should always be stored with the machine when not in use.

23. **DIRECTION OF FEED.** Feed workpiece into a blade or cutter against the direction of rotation of the blade or cutter only.

TABLE SAW SAFETY

SAW BLADE GUARD ASSEMBLY, ANTI-KICKBACK ASSEMBLY AND RIVING KNIFE

Your table saw is equipped with a blade guard assembly, anti-kickback assembly and riving knife that covers the blade and reduces the possibility of accidental blade contact. The riving knife is a flat plate that fits into the cut made by the saw blade and effectively fights kickback by lessening the tendency of the blade to bind in the cut. The blade guard assembly and anti-kickback assembly can only be used when making through cuts that sever the wood. When making rabbets and other cuts that make non through cuts, the blade guard assembly and anti-kickback assembly must be removed and riving knife lowered to the non through cut position marked on the riving knife. Two anti-kickback pawls are located on the sides of the riving knife that allow the wood to pass through the blade in the cutting direction but reduce the possibility of the material being thrown backwards toward the operator. Use all components of the guarding system (blade guard assembly, riving knife and anti-kickback assembly) for every operation for which they can be used including all through cutting. If you elect not to use any of these components for a particular application exercise additional caution regarding control of the workpiece, the use of push sticks, the position of your hands relative to the blade, the use of safety glasses, the means to avoid kickback and all other warnings contained in this manual and on the saw itself. Replace the guarding systems as soon as you return to thru-cutting operations. Keep the guard assembly in working order.

KICKBACKS

KICKBACKS: Kickbacks can cause serious injury. A kickback occurs when a part of the workpiece binds between the saw blade and the rip fence, or other fixed object, and rises from the table and is thrown toward the operator. Kickbacks can be avoided by attention to the following conditions.

How to Avoid Them and Protect Yourself from Possible Injury:

- a. Be certain that the rip fence is parallel to the saw blade.
- b. Do not rip by applying the feed force to the section of the workpiece that will become the cut-off (free) piece. Feed force when ripping should always be applied between the saw blade and the fence; use a push stick for narrow work, 6 in. (152 mm) wide or less.
- c. Keep saw blade guard assembly, riving knife and anti-kickback assembly in place and operating properly. If anti-kickback assembly is not operational, return your unit to the nearest authorized service center for repair. The riving knife must be in alignment with the saw blade and the anti-kickback assembly must stop a kickback once it has started. Check their action before ripping by pushing the wood under the anti-kickback assembly. The teeth must prevent the wood from being pulled toward the front of the saw.
- d. Plastic and composite (like hardboard) materials may be cut on your saw. However, since these are usually quite hard and slippery, the anti-kickback pawls may not stop a kickback. Therefore, be especially attentive to following proper set up and cutting procedures for ripping.
- e. Use saw blade guard assembly, anti-kickback assembly and riving knife for every operation for which it can be used, including all through-sawing.
- f. Push the workpiece past the saw blade prior to release.
- g. Never rip a workpiece that is twisted or warped, or does not have a straight edge to guide along the fence.
- h. Never saw a large workpiece that cannot be controlled.
- i. Never use the fence as a guide or length stop when crosscutting.
- j. Never saw a workpiece with loose knots, flaws, nails or other foreign objects.
- k. Never rip a workpiece shorter than 10 in. (254 mm).
- l. NEVER use a dull blade – replace or have resharpened.
- m. NEVER use a rip fence and miter gauge together.
- n. Keep hands out of saw blade.

ELECTRICAL REQUIREMENTS AND SAFETY

POWER SUPPLY AND MOTOR SPECIFICATIONS

WARNING

To avoid electrical hazards, fire hazards, or damage to the tool, use proper circuit protection. Use a separate electrical circuit for your tool. Your table saw is wired at the factory for 120V operation. Connect to a 120V, 15 Amp circuit and use a 15 Amp time delay fuse or circuit breaker. To avoid shock or fire, if power cord is worn, cut, or damaged in any way, have it replaced immediately.

GROUNDING INSTRUCTIONS

WARNING

This tool must be grounded while in use to protect the operator from electrical shock.

IN THE EVENT OF A MALFUNCTION OR BREAKDOWN, grounding provides a path of least resistance for electric currents and reduces the risk of electric shock. This tool is equipped with an electrical cord that has an equipment-grounding conductor and a grounding plug. The plug must be plugged into a matching receptacle that is properly installed and grounded in accordance with all local codes and ordinances.

DO NOT MODIFY THE PLUG PROVIDED. If it will not fit the receptacle, have the proper receptacle installed by a qualified electrician.

IMPROPER CONNECTION of the equipment grounding conductor can result in risk of electric shock. The conductor with the green insulation (with or without yellow stripes) is the

equipment grounding conductor. If repair or replacement of the electrical cord or plug is necessary, do not connect the equipment grounding conductor to a live terminal.

CHECK with a qualified electrician or service person if you do not completely understand the grounding instructions, or if you are not certain the tool is properly grounded.

USE only 3-wire extension cords that have three-pronged grounding plugs with three-pole receptacles that accept the tool's plug. Repair or replace damaged or worn cords immediately.

Use a separate electrical circuit for your tool. This circuit must not be less than #14 wire and should be protected with a 15 Amp time delay fuse. Before connecting the motor to the power line, make sure the switch is in the off position and the electric current is rated the same as the current stamped on the motor nameplate. Running at a lower voltage will damage the motor.

USE THE PROPER EXTENSION CORD. Make sure your extension cord is in good condition. Use an extension cord heavy enough to carry the current your product will draw. An undersized cord will cause a drop in line voltage resulting in loss of power, overheating and burning out of the motor. The table below shows the correct size to use depending on cord length and nameplate ampere rating. If in doubt, use the next heavier gauge. The smaller the gauge number, the heavier the cord.

GUIDELINES FOR EXTENSION CORDS

Make sure your extension cord is properly wired and in good condition. Always replace a damaged extension cord or have it repaired by a qualified technician before using it. Protect your extension cords from sharp objects, excessive heat and damp or wet areas.

MINIMUM GAUGE FOR EXTENSION CORDS (AWG)					
(When using 120 volts only)					
Ampere Rating		Total length of Cord			
More Than	Not More Than	25 (7.62)	50 15.24	100 30.48	150 ft. 45.72 m)
		AWG- American Wire Gauge			
0	6	18	16	16	14
6	10	18	16	14	12
10	12	16	16	14	12
12	16	14	12	Not Recommend	

⚠ WARNING

This tool is for indoor use only. Do not expose to rain or use in damp locations.

This tool is intended for use on a circuit that has a receptacle like the one illustrated in Fig. 1. Fig. 1 shows a three-pronged electrical plug and receptacle that has a grounding conductor. If a properly grounded receptacle is not available, an adapter (Fig. 2) can be used to temporarily connect this plug to a two-contact grounded receptacle.

The adapter (Fig. 2) has a rigid lug extending from it that **MUST** be connected to a permanent earth ground, such as a properly grounded receptacle box.

⚠ CAUTION

In all cases, make certain the receptacle is properly grounded. If you are not sure, have a qualified electrician check the receptacle.

Fig. 1

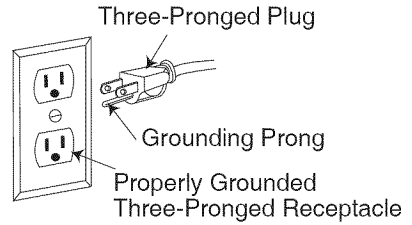
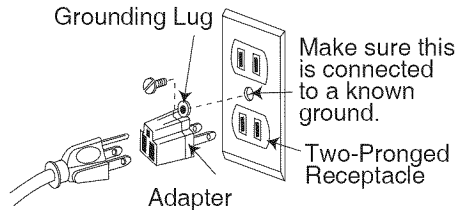

Fig. 2



ACCESSORIES AND ATTACHMENTS

RECOMMENDED ACCESSORIES

WARNING

Visit your Sears Hardware Department or see the Craftsman Power and Hand Tools Catalog to purchase recommended accessories for this power tool.

308K DADO INSERT PLATE

WARNING

To avoid the risk of personal injury:

- Do not use adjustable (wobble) type dados or carbide tipped dado blades.
- Only use stackable dados.
- Maximum dado width is 1/2 in.
- Do not use a dado with a diameter larger than 6 in.
- Do not use molding head set with this saw.
- Do not modify this power tool or use accessories not recommended by Sears.

TOOLS NEEDED FOR ASSEMBLY

SUPPLIED



Blade wrench



Blade wrench



4 mm hex wrench

NOT SUPPLIED



Flat bladed screwdriver



Phillips screwdriver

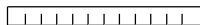

Straight edge



Adjustable wrench and/or 8 mm, 10 mm, 13 mm, 14 mm, 17 mm wrench

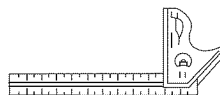

Combination square

CARTON CONTENTS

Separate all parts from packing materials. Check each part with the illustration on the next page and the "Table of Loose Parts" to make certain all items are accounted for, before discarding any packing material.

NOTE: To make assembly easier, keep contents of box together.

WARNING

If any part is missing or damaged, do not attempt to assemble the table saw, plug in the power cord, or turn the switch ON until the missing or damaged part is obtained and is installed correctly. Call 1-800-843-1682 for missing or damaged parts.

TABLE OF LOOSE PARTS TABLE SAW

ITEM	DESCRIPTION	QUANTITY
A	Table saw assembly	1
B	Blade guard assembly	1
C	Anti-kickback pawls assembly	1
D	Riving knife hardware bag assembly	1
E	Rip fence	1
F	Miter gauge	1
G	Blade wrench	2
H	Hex wrench	1
I	Push stick	1
J	Rear table extension	1
K	Rear table extension tube	2
L	Power cord storage	1
M	Table extension wing hardware bag assembly	1
N	Blade	1
O	Dust bag	1
P	Handwheel handle hardware bag	1
Q	Hex bolts, washers	4 each
R	Leg handle hardware assembly	1

STAND

S	Riving knife storage (locking handle)	1 set
	Blade guard storage, screws	
T	Roller wheel hardware assembly	2
U	Stand	1

UNPACKING YOUR TABLE SAW

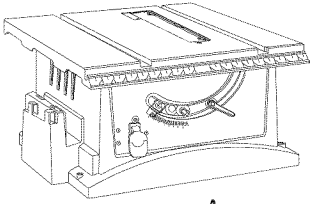

A

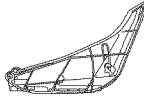

B



C

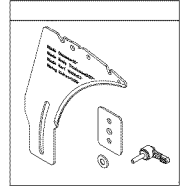

D

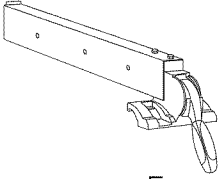

E

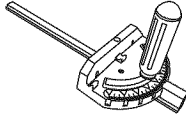

F



G



H

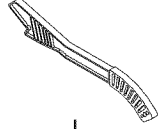

I

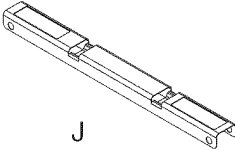

J

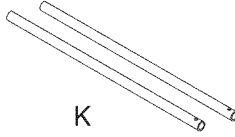

K

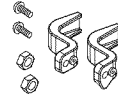

L



M

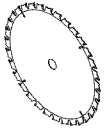

N



O

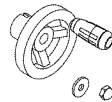

P



Q

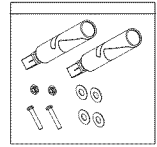

R

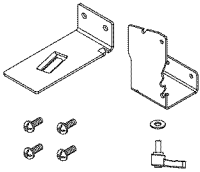

S

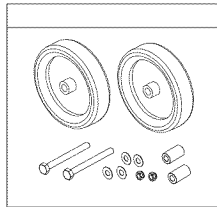

T

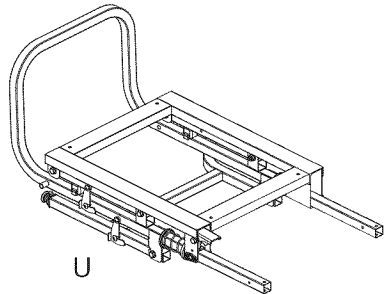

U

KNOW YOUR TABLE SAW

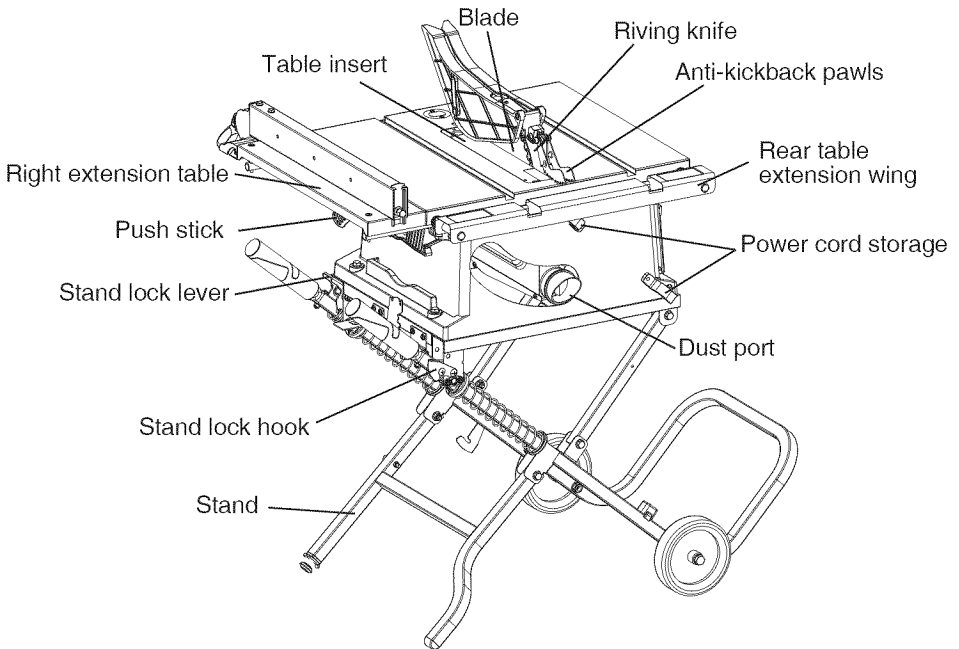
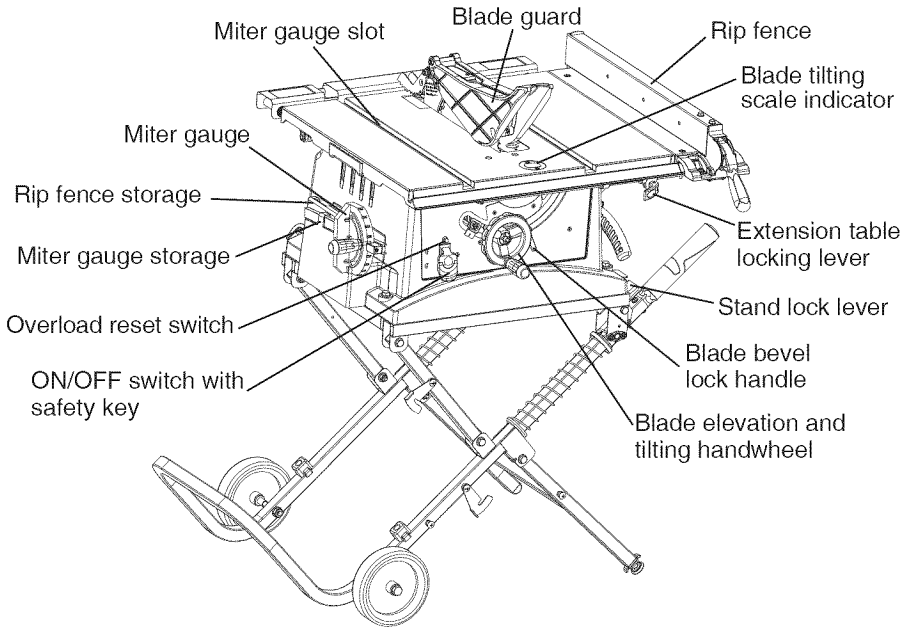

GLOSSARY OF TERMS

ANTI-KICKBACK PAWLS – To prevent the workpiece being kicked upward or back toward the front of the table saw by the spinning blade.

ARBOR – The shaft on which the blade or dado is mounted.

BEVEL CUT – An angle cut made through the face of the workpiece.

BLADE BEVEL SCALE – To measure if the angle of the blade is tilted when set for a bevel cut.

BLADE ELEVATION AND TILTING HANDWHEEL – To raise and lower the blade or tilt the blade to the angle between 0° and 45° for bevel cuts.

BLADE GUARD – A clear plastic cover that positions over the blade while cutting.

COMPOUND CUT – A simultaneous bevel and miter cut.

CROSSCUT – A cut made across the width of the workpiece.

DADO – Special cutting blades that are used to cut grooves in a workpiece.

FEATHERBOARD – When ripping a workpiece on your table saw, this keeps it firmly and safely against the rip fence. It also helps prevent chatter, gouging, and dangerous kickback.

FREEHAND – Performing a cut without using a rip fence, miter gauge, hold down or other proper device to prevent the workpiece from twisting during the cutting operation.

GUM – A sticky sap from wood products.

HEEL – Misalignment of the blade.

JAMB NUT – Nut used to lock another nut in place on a threaded rod or bolt.

KERF – The amount of material removed by the blade cut.

KICKBACK – Occurs when the saw blade binds in the cut and violently thrusts the workpiece back toward the operator.

MITER CUT – An angle cut made across the width of the workpiece.

MITER GAUGE – A guide used for crosscutting operations that slides in the table top channels (grooves) located on either side of the blade. It helps make accurate straight or angle crosscuts.

NON-THROUGH SAWING – refers to any cut that does not completely cut through the workpiece.

OVERLOAD RESET SWITCH –

Protects the motor if it overloads during operation, provides a way to restart the saw.

PUSH STICK – Used to push workpieces when performing ripping operations.

PUSH BLOCK – Used for ripping operation when the workpiece is too narrow to use a push stick. Always use a push block for rip widths less than 2 in.

RESAWING – Flipping material to make a cut the saw is not capable of making in one pass.

⚠ WARNING

Resawing IS NOT recommended.

REVOLUTIONS PER MINUTE (RPM)

– The number of turns completed by a spinning object in one minute.

RIP FENCE – A guide used for rip cutting which allows the workpiece to cut straight.

RIPPING – Cutting with the grain of the wood or along the length of the workpiece.

RIVING KNIFE – A metal piece of the guard assembly located behind and moves with the blade. Slightly thinner than the saw blade, it helps keep the kerf open and prevents kickback.

SAW BLADE PATH – The area of the workpiece or table top directly in line with the travel of the blade or the part of the workpiece that will be cut.

SET – The distance between two saw blade tips, bent outward in opposite directions to each other. The further apart the tips are, the greater the set.

TABLE INSERT – Insert that is removed from the table to install / remove blades. It is also removed for dado cutting. When dado cutting, a dado insert plate must be used.

THROUGH SAWING – Making a cut completely through the length or width of a workpiece.

WORKPIECE – Material to be cut.

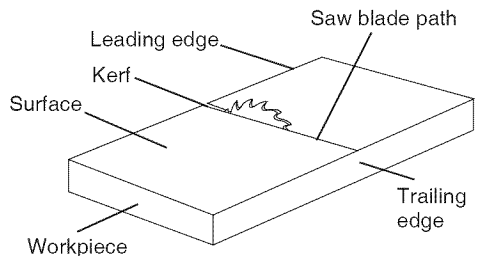

NOTE: Blade guard assembly is removed for purposes of illustration only.

ASSEMBLY AND ADJUSTMENTS

⚠ WARNING

For your safety, never connect plug to power source receptacle until all assembly and adjustment steps are complete, and you have read and understood the safety instructions.

⚠ WARNING

- Stand may pop up unexpectedly without weight of saw on stand. **IN ORDER TO AVOID INJURY, VERIFY THAT THE BAND IS NOT CUT AND THAT THE LOCK HOOKS LOCATED IN THE FRONT OF THE STAND ARE LOCKED ONTO THE STOP SCREWS BEFORE MOUNTING THE TABLE SAW.**
- Do not release the stand hooks until the table saw is properly attached to the stand.
- To avoid injury, keep hands on the over-mold portion of the handle and away from the spring.

ASSEMBLING THE ROLLER WHEELS AND HANDLES TO STAND (Fig. A, A-1, B)

1. Attach one roller wheel to the leg using the long hex bolt (1), the two flat washers (2), the sleeve (3) and the lock nut (4), as shown. (Fig. A-1) Tighten the nut (4) using a 17 mm wrench.
2. Repeat the above steps for the other roller wheel to the front leg.
3. Insert one handle (5) into the leg tube (6), fasten by bolts (7), two washers (8) and nut (9). Tighten using a 10 mm wrench and screwdriver. (Fig. B)
4. Repeat the above steps for the other handle.

Fig. A

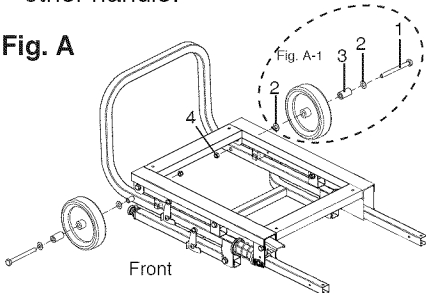

Fig. A-1

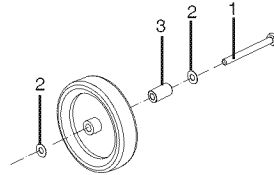
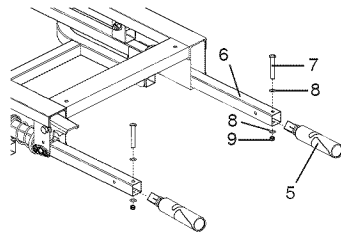

Fig. B



ASSEMBLING TABLE SAW TO STAND (Fig. C)

1. Lift the saw body (1) and place on the stand (2), aligning the four mounting grooves (3) of the saw base with the four mounting holes on the top plate of the stand. The wheels should be on the left side when facing the front of saw.
2. Attach the table saw to the stand with four hex head bolts (4) and four washers (5).
3. Tighten all mounting bolts with a 13 mm wrench.

Fig. C

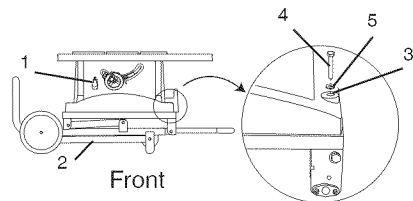

SETTING UP THE STAND (Fig. D, E, F)

1. Cut the plastic band holding the stand assembly together. Lift up the Saw/Stand assembly into the vertical position as shown. (Fig. D)
2. Release hook (1) securing leg set (2) to frame. Raise leg set all the way up. Then lower stand until leg set rests on floor. (Fig. D, E)
3. Release hook (3) securing table to frame.
4. With one hand, grasp stand handle by its grip (4). Place foot in front of wheel (5) for leverage. Grasp wheel side of table at the grip (6) and raise table until it snaps into place. (Fig. D, F)

WARNING

To avoid being pinched, grasp handle only by grip. Grasping lower on handle bar will result in injury.

5. Secure hook (7) from table to frame pin (8) to lock table into place. Push down slightly on the table to secure hook to pin.

Fig. D

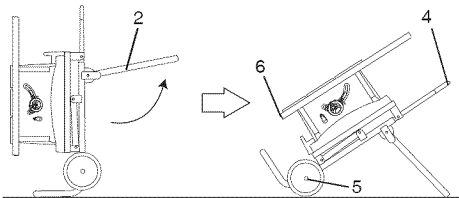

Fig. E

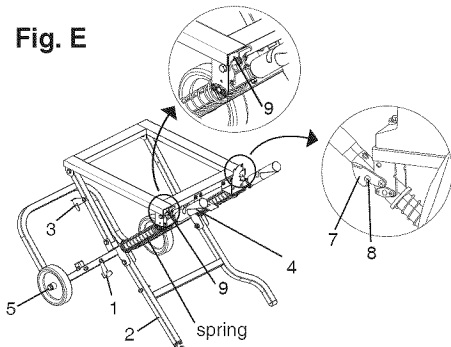
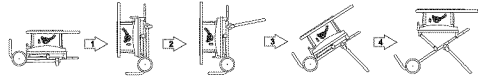

Fig. F



FOLDING THE STAND FOR TRANSPORT OR STORAGE (Fig. D, E, G)

1. Release hook (7) from frame pin (8).
2. With one hand, lift up slightly wheel side of table on the grip (6). With the other hand, depress lock lever (9) to release table from frame.
3. Push down on wheel side of table saw to lower it onto stand.
4. Raise stand to vertical position. Secure hook (3).
5. Lower leg set (2) to frame. Secure hook (1).
6. Tilt saw back onto wheels. Move saw to desired location for operation or storage. Saw can be storage in vertical position.

Fig. G

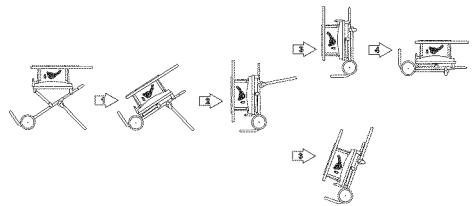

STORAGE (Fig. H, I, J, L, M, O)

Rip fence, Miter gauge (Fig. H)

Storage brackets for the rip fence (1) and miter gauge (2) are built into the base and are located on the left side of the saw housing.

Fig. H

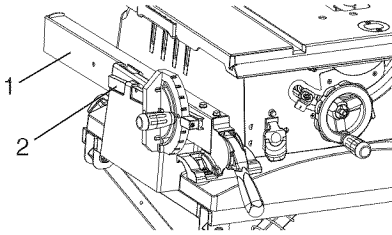

Push stick (Fig. I, J)

Attach the metal push-stick storage bracket (1) into the provided slots (2) on the right side of the body shell. The bracket will snap down into place. Place the push stick (3) into the bracket as shown in Fig. J.

Fig. I

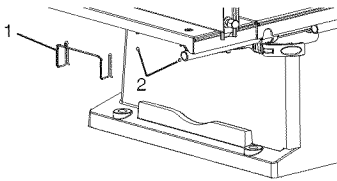

Blade wrenches (Fig. J)

Insert the two blade wrenches into the slot (4) located on the right side of the saw housing, under the push stick.

Fig. J

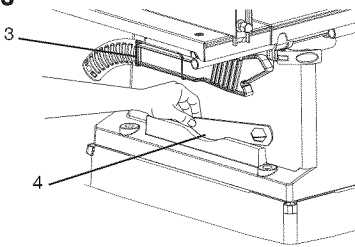

INSTALLING THE BLADE GUARD, ANTI-KICKBACK PAWLS AND RIVING KNIFE STORAGE (Fig. K)

1. Attach the retaining clip (1) to the stand (2) using two screws (3). Tighten screws securely using a screwdriver.
2. Attach the set plate (4) to the stand (2) using two screws (3) and tighten screws securely. Thread the washer

(5) and the locking handle (6) to the bottom of the set plate (4).

Fig. K

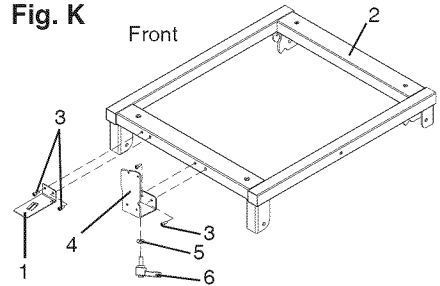

Anti-kickback pawls (Fig. L)

Storage for the anti-kickback pawls (1) is located on the right side of the stand.

1. Take the anti-kickback pawl (1) and slide the red locking knob (2) up and press the anti-kickback pawl down to secure the entire assembly on the storage. Release the locking knob (2).

Fig. L

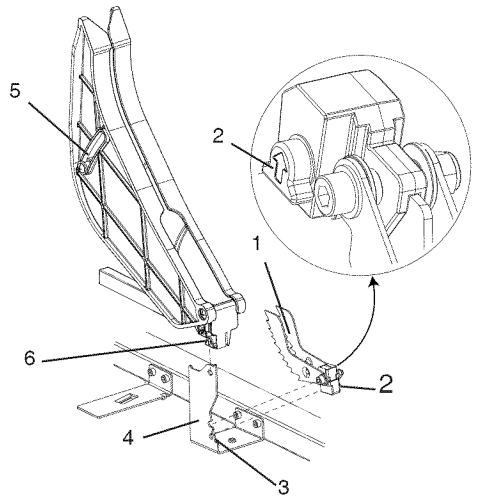

Blade guard assembly (Fig. L)

Storage for the blade guard assembly is located on the right side of the stand.

1. Take the blade guard assembly (5) and slide the locking knob (6) up and press the guard assembly down so that the entire assembly is located on the set plate (4). Release the locking knob (6).

Riving knife (Fig. M)

Storage brackets for the riving knife are located on the right side of the stand.

1. Remove the washer (8) and the locking handle (10).
2. Insert riving knife (9) under the set plate (4) and between the retaining clip (7).
3. Tighten the washer (8) and the locking handle (10).

Fig. M

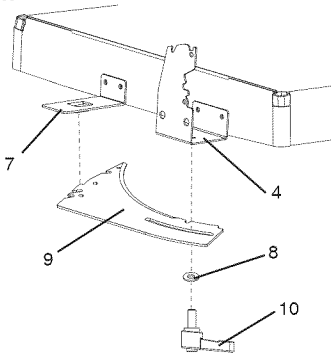

INSTALLING THE POWER CORD STORAGE CLAMPS (Fig. N)

1. Attach the power cord storage clamp (1) into the hole set on the rear side of the table saw base with screw (2) and nut (3). **NOTE:** The nut is placed inside the base.
2. Repeat for the other clamp, to be located on the bottom right on saw base.

Fig. N

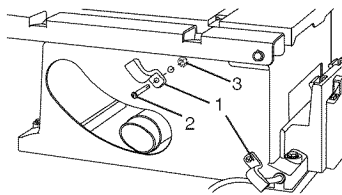

Power cord (Fig. O)

Wrap the power cord (2) onto the storage clamps (1) when saw is not in use. This can prevent damage to

the cord. Do not wrap the power cord around the dust port (3).

Fig. O

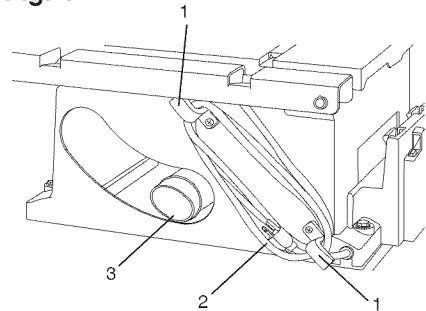

ASSEMBLING THE BLADE ELEVATION/TILT HANDWHEEL (Fig. P)

1. Attach the blade elevation handwheel (1) to the elevation rod (2) at the front of the saw. Make sure the slot (3) in the hub of the handwheel (1) engage with the pins (4), turn handle 90 degrees to align pin with the recessed slot to hold the handle in place.
2. Attach and tighten the crown nut (5) and washer (6) with a 13 mm wrench.

Fig. P

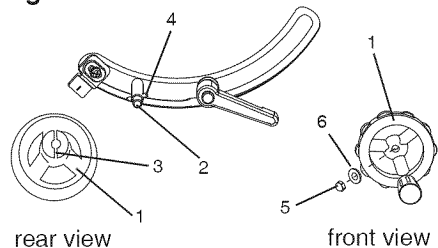

INSTALLING THE REAR TABLE EXTENSION (Fig. Q, R)

1. Insert the two tubes (2) into the rear table extension (1). (Fig. Q)

NOTE: They must be inserted into the back of the extension with the bent end last so that the bar will hold the extension in place. The two openings on the rear table (4) must line up with the miter gauge slots on the main table.

2. Snap plastic stops (3) over the two rear table extension tubes (2). Make sure the locating pin in the black plastic stops fits into the matching hole in the extension tube. This will 'lock' the tube into the extension. (Fig. Q)
3. Insert the rear table extension tubes (2) into the two extension tube brackets under the table (5).

Fig. Q

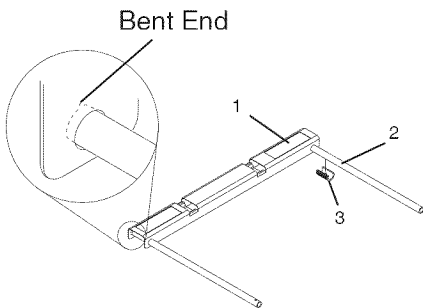

4. Thread the screw (6) through the hole in either side tube with a screwdriver. **NOTE:** Only one side is needed to have a screw inserted. Tighten with a screwdriver, making sure not to overtighten the screw (6). (Fig. R)

Fig. R

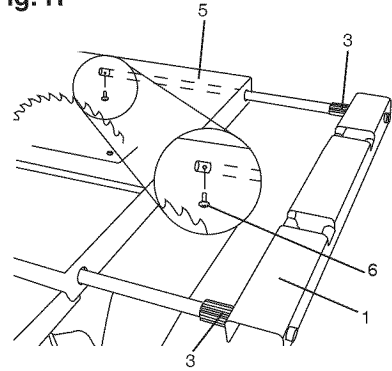

INSTALLING THE BLADE (Fig. S, T, U)



To avoid injury from an accidental start, make sure the switch is in the OFF position and the plug is not connected to the power source outlet.

1. Remove the table insert (1) by snapping out from the hole (8). Raise the blade arbor to the maximum height by turning the blade elevation handwheel clockwise. (Fig. S)

Fig. S

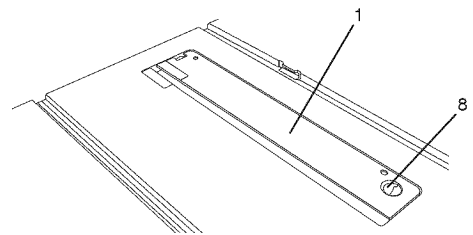

- Remove the arbor nut (2) and outer blade flange (3). (Fig. T)

Fig. T

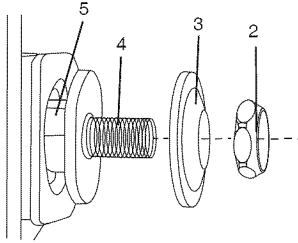

- Place the blade onto the arbor (4) with the blade teeth pointing forward to the front of the saw. (Fig. U)
NOTE: Leave the plastic strip around the saw blade at this time. Remove before using the saw for the first time.
- Make sure the blade fits flush against the inner flange.
- Clean the outer blade flange (3) and install it onto the arbor (4) and against the blade. (Fig. T)
- Thread the arbor nut (2) onto the arbor, making sure the flat side of the nut is against the blade, then hand-tighten. (Fig. T)
- To tighten the arbor nut (2), place the open-end wrench (6) on the flats of the saw arbor (5) to keep the arbor from turning. (Fig. U)
- Place the box-end wrench (7) on the arbor nut (2) and turn clockwise (to the rear of the saw table). (Fig. U)
- Do not replace insert until after the next step of adding the riving knife assembly.

Fig. U

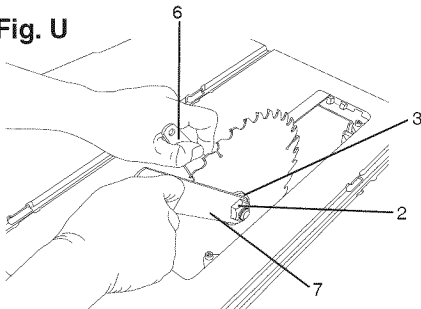

RIVING KNIFE ASSEMBLY

▲ WARNING

- To avoid injury from an accidental start, make sure the switch is in the OFF position and the plug is disconnected from the power source outlet.
- Never operate this saw without the riving knife in the correct position.

Installing the riving knife assembly (Fig. V, W, W-1)

NOTE: The table insert should be removed and the blade raised to its highest position before proceeding.

- Loosen the blade lock handle (1). Turn and move the handwheel (2) to 45° on the bevel scale.
- Tighten the bevel lock handle.

Fig. V

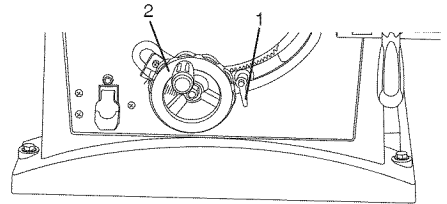

- Place the riving knife (3) on the mounting bracket (4) located behind the saw blade. The two pins (5) on the bracket should fit into the slot on the riving knife.
- Make sure the riving knife (3) is in its highest position.
- Insert the set plate (6) making sure the two outer holes fit into the two pins on the mounting bracket.
- Insert the washer (7) into the lock lever (8) and insert into the middle hole the set plate and tighten.
- Loosen the blade lock handle (1) and return the blade to 0° and lock.
- Place the table insert back into position.

▲ WARNING

- To avoid the lock lever interfering the table insert, after tighten the riving knife, position the lock lever pointing downward before using saw. Failure to maintain a level insert can result in serious injury to the operator.
- The lever can be pulled out to allow it to be turned to a new position downward. (Fig. W-1)

Fig. W

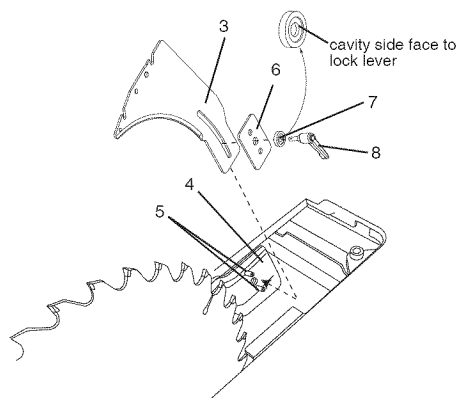
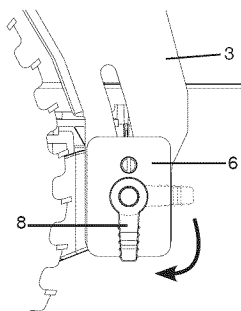

Fig. W-1



Aligning the riving knife (Fig. X)

▲ WARNING

- To avoid injury from an accidental start, make sure the switch is in the OFF position and the plug is disconnected from the power source outlet.

- Never operate this tool without the riving knife in the correct position.
- Never operate this tool without the blade guard in place for all through sawing operations.
- This adjustment was made at the factory, but it should be rechecked and adjusted if necessary.

1. Remove the table insert and raise the blade to the maximum height by turning the blade elevation handwheel clockwise.
2. Remove the blade guard and anti-kickback pawl assembly.
3. Adjust the blade to the 0° vertical position by unlocking the blade tilting lock knob and turning the bevel tilting handwheel counterclockwise, and then lock into position.
4. To see if the blade (1) and riving knife (2) are correctly aligned, lay a combination square along the side of the blade and against the riving knife (making sure the square is between the teeth of the blade).
5. Tilt the blade to the 45° position and check the alignment again.

NOTE:

- This table saw is provided with a 10 inch diameter blade with a body thickness of 0.07 in. (1.8 mm) thick with a kerf of 0.10 in. (2.6 mm). The riving knife is 0.09 in. (2.2 mm) thick. The blade diameter and the blade body and kerf dimensions must be properly matched with the riving knife thickness.
- The maximum radial distance between the riving knife and the toothed rim of the saw blade is 0.12 in ~ 0.31 in. (3 mm ~ 8 mm)
- The tip of the riving knife shall not be lower than 0.04 in. ~ 0.2 in. (1 mm ~ 5 mm) from the tooth peak.
- The riving knife is thinner than the width of the kerf by approximately 1/64 in. (0.4 mm) on each side.

- The blade body must be thinner than the thickness of the riving knife but the blade kerf must be thicker than the riving knife.
7. Check the riving knife and blade alignment again at both 0° and 45°.
 8. Replace the table insert, blade guard and anti-kickback pawl assembly.

Fig. X

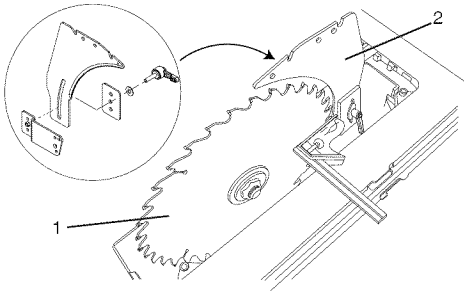

▲ WARNING

To avoid possible injury and damage to the workpiece, be sure to **INSTALL THE BLADE WITH THE TEETH POINTING TOWARD THE FRONT OF TABLE** in the direction of the rotation arrow on the blade guard.

ADDITIONAL BLADE ADJUSTMENTS (Fig. Y)

NOTE: The adjusting mechanism is located above the blade height adjusting hand under the tabletop. If the front and rear measurements are not the same.

If the blade is partial to right side:

1. Turn the left adjustment screw (2) counterclockwise and adjust the right side adjustment screw (3) clockwise.
2. Remeasure, as described in steps 4 to 9 in the prior section.
3. When alignment is achieved, turn the left adjustment screw (2) until it touches the pivot rod (4).

If the blade is partial to left side:

1. Turn the right adjustment screw (3) counterclockwise and adjust the left side adjustment screw (2) clockwise.
2. Remeasure, as described in steps 4 to 9 in the prior section.
3. When alignment is achieved, turn the right adjustment screw (3) until it touches the pivot rod (4).

Fig. Y

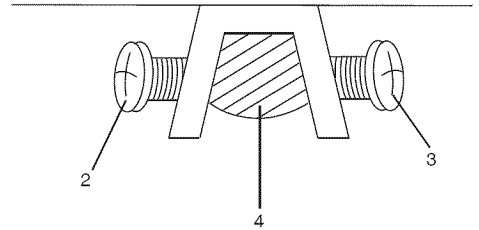

BLADE GUARD ASSEMBLY

▲ WARNING

To avoid injury from an accidental start, make sure the switch is in the **OFF** position and the plug is disconnected from the power source outlet.

- When installing the blade guard, cover the blade teeth with a piece of folded cardboard to protect yourself from possible injury.
- **Never operate this machine without the blade guard in place for all through sawing operations.**

Installing the blade guard and anti-kickback pawl assembly (Fig. Z, AA, BB)

1. Make sure the blade is elevated to its maximum height and the bevel is set at 0°. Make sure the bevel lock handle is tight.
2. Take the anti-kickback pawl assembly (1) and locate the red sliding knob and push the locking knob (2) up. (Fig. Z)

- Place the front of assembly into the back slot on the riving knife and push downward. Release the locking knob. Make sure the lock knob is engaged in the hole and that there is no movement of the assembly. (Fig. Z)

Fig. Z

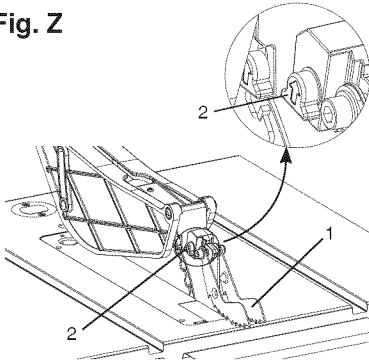

- Take the blade guard assembly and locate the red sliding locking knob (3) on the back of assembly. (Fig. AA)

Fig. AA

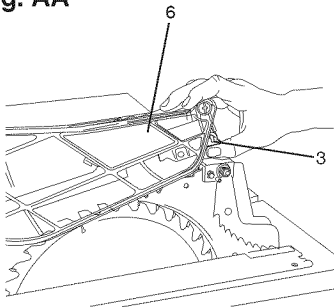

- Insert the blade guard assembly onto the riving knife so that the pin (4) engages into slot (5) completely. (Fig. BB)
- Slide the red locking knob (3) up and press the guard assembly down so that the entire assembly is flat on the riving knife. Release the locking knob (3).

- Make sure that the assembly is locked in place both in front and back.

Fig. BB

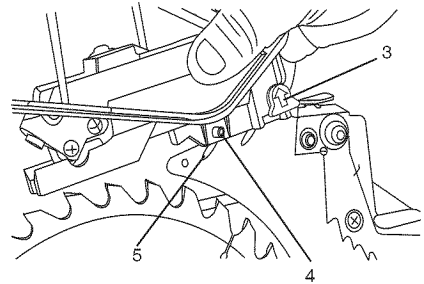

Removing the blade guard and anti-kickback pawl assembly (Fig. Z, BB)

⚠ WARNING

To avoid injury from an accidental start, make sure the switch is in the OFF position and the plug is disconnected from the power source outlet.

- With the blade elevation handwheel raise the blade to the maximum height.
- Loosen the blade lock handle and then turn the handwheel to 45° on the bevel scale.
- Tighten the bevel lock handle.
- Remove the anti-kickback pawl assembly by pressing up on the red knob (2) and lifting the assembly off the riving knife. (Fig. Z)
- Remove the blade guard assembly by pressing up on the red knob (3) and lifting the assembly off the riving knife. (Fig. BB)

AVOIDING KICKBACKS (Fig. CC)

(Work thrown back towards you) by keeping the blade sharp, the rip fence parallel to the saw blade and by keeping the riving knife, anti-kickback pawls and guards in place, aligned and functioning. Do not release work before passing it completely beyond the saw blade. Do not rip work that is twisted, warped or does not have a straight edge to guide it along the fence. Do not attempt to reverse out of a cut with the blade running.

▲ WARNING

Improper riving knife alignment can cause “kickback” and serious injury.

Fig. CC

Anti-kickback pawl

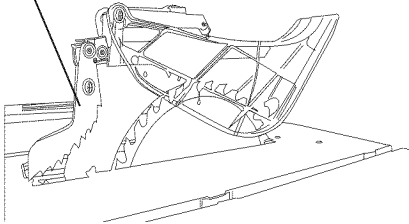

INSTALLING THE DUST BAG (Fig. DD)

▲ WARNING

- Do not use this saw to cut and/or sand metals. The hot chips or sparks may ignite sawdust or the bag material.
- To prevent hazard, clean and remove sawdust from under the saw frequently.

1. Place the dust bag (1) around the neck (3) of the dust port (2) and tie the dust bag by pulling the string tight and secure with the spring-loaded tie clip (4).

Fig. DD

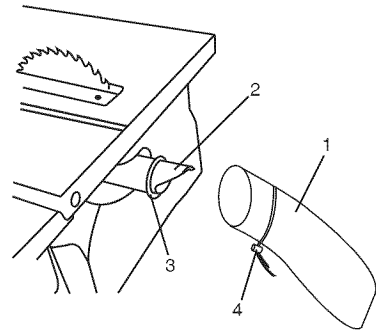

RIP FENCE (Fig. EE)

1. Lift upward on the rip fence handle (1) so the rear holding clamp (2) is fully extended.
2. Place the rip fence on the saw table, position the set plate (3) under the front of fence and then lower the back of fence onto the table.
3. Push down on the fence handle (1) to lock.

Fig. EE

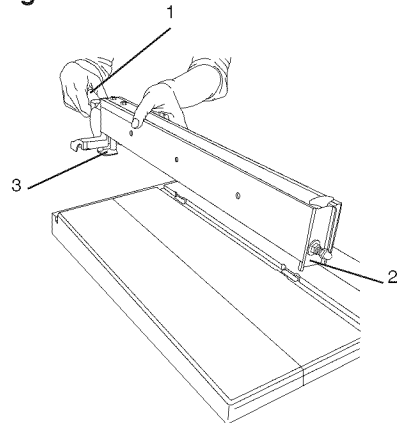

RIP FENCE ADJUSTMENT (Fig. FF)

1. The fence (1) is moved by lifting up on the handle (2) and sliding the fence to the desired location. Pushing down on the handle locks the fence in position.
2. Position the fence on the right side of the table and along the edge miter gauge groove.
3. Lock the fence handle. The fence should be parallel with the miter gauge groove.
4. If adjustment is needed to make the fence parallel to the groove, do the following:
 - Loosen the two bolts (3) and lift up on the handle (2).
 - Hold the fence bracket (4) firmly against the front of the saw table. Move the fence until it is parallel with the miter gauge groove.
 - Push the handle down and tighten both bolts.
5. If fence is loose when the handle is in the locked (downward) position, do the following:
 - Move the handle (2) upward and turn the adjusting nut (5) clockwise until the rear clamp is snug.
 - Over-tightening the adjusting bolts will cause the fence to come out of alignment.

WARNING

Failure to properly align fence can cause “kickback” and serious injury.

Fig. FF

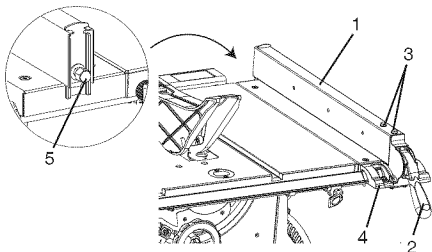

RIP FENCE INDICATOR ADJUSTMENT (Fig. GG)

1. The rip fence indicator (6) points to the measurement scale. The scale shows the distance from the side of the fence to nearest side of the blade.
2. Measure the actual distance with a rule. If there is a difference between the measurement and the indicator, adjust the indicator (6).
3. Loosen the screw (7) and slide the indicator to the correct measurement on the scale. Tighten the screw and remeasure with the rule.

Fig. GG

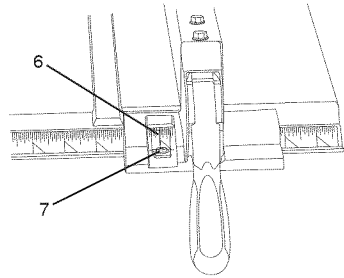

ADJUSTING THE MITER GAUGE (Fig. HH)

1. Loosen the lock handle (1) to allow the miter body (2) to rotate freely. Position the miter body at 90° so the positive detent secures its position. Tighten the lock handle to hold the miter body in position.
2. If the pointer (3) requires adjustment, loosen the screw under the pointer with a screwdriver. Adjust the pointer to 90° on the scale, then firmly tighten the adjustment screw.
3. To change angles on the miter gauge, loosen the lock handle (1) and rotate the miter body to the desired angle as indicated by the scale. Secure in position by tightening the lock handle.

Fig. HH

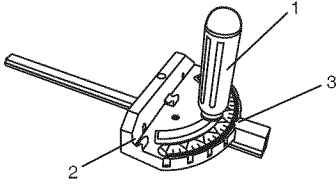

ADJUSTING THE TABLE INSERT (Fig. II)

⚠ WARNING

To avoid serious injury, the table insert (2) must be level with the table. If the table insert is not flush with the table, adjust the two bolts (1) with a 4 mm hex wrench until it is parallel with the table.

NOTE: To raise the insert, turn the hex screws counterclockwise. To lower the insert, turn the hex screws clockwise. Do not remove the insert, adjustments need to be made with the insert in place to get the proper level.

Fig. II

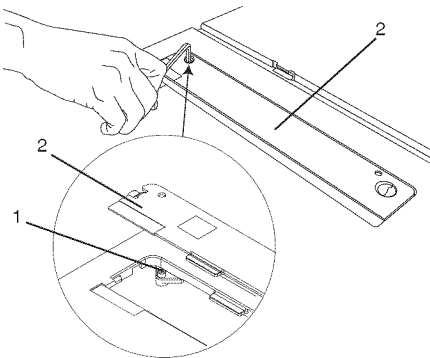

REMOVING THE BLADE (Fig. S, T, U)

⚠ WARNING

To avoid injury from an accidental start, make sure the switch is in the OFF position and the plug is disconnected from the power source outlet.

1. Remove the table insert by snapping out from the hole (8). (Fig. S)
2. Raise the blade to the maximum height by turning the blade elevation handwheel clockwise .
3. Adjust the blade to the 90° vertical position by unlocking the blade tilting lock knob, push in the blade elevation wheel and turn the bevel tilting handwheel counterclockwise, and then lock into position.
4. Place the box-end wrench (7) on the arbor nut (2). (Fig. U)
5. Place the open-end wrench (6) on the flats of the saw arbor to keep the arbor from turning and loosen the arbor nut (2). (Fig. U)
6. Then remove the blade. Clean but do not remove the inner blade flange before reassembling the blade.

ADJUSTING THE 90° AND 45° POSITIVE STOPS (Fig. JJ, JJ-1)

Your saw has positive stops that will quickly position the saw blade at 90° and 45° to the table. Make adjustments only if necessary.

90° Stop

1. Disconnect the saw from the power source.
2. Raise the blade to the maximum elevation.
3. Loosen the blade bevel lock handle and move the blade to the maximum vertical position and tighten the bevel lock handle.
4. Place a combination square on the table and against the blade (1) to determine if the blade is 90° to the table. (Fig. Z)
5. If the blade is not 90° to the table, loosen or tighten (depending on whether you are increasing or decreasing the degrees) the hex bolt (3) with a 5 mm hex wrench until you achieve 90°. (Fig. Z-1)
6. Loosen the bevel lock handle and reset the blade at the maximum vertical position, then tighten the bevel lock handle.
7. Check again to see if the blade is 90° to the table. If not, repeat step 5.
8. Lastly, check the bevel angle scale. If the pointer does not read 90°, loosen the screw holding the pointer and move the pointer so it is accurate at 0° and retighten the pointer screw.

Fig. JJ

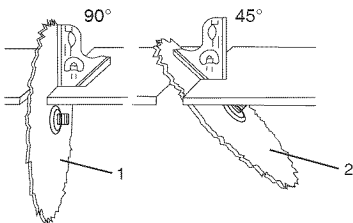

45° Stop

1. Disconnect the saw from the power source.
2. Raise the blade to the maximum elevation.
3. Loosen the blade bevel lock handle and move the blade to the maximum bevel position (45°) and tighten the bevel lock handle.
4. Place a combination square on the table and against the blade (2) to determine if the blade is 45° to the table. (Fig. Z)
5. If the blade is not 45° to the table, loosen or tighten (depending on whether you are increasing or decreasing the degrees) the hex bolt (4) with a 5 mm hex wrench until you achieve 45°. (Fig. Z-1)
6. Loosen the bevel lock handle and reset the blade at the maximum bevel position (45°), then tighten the bevel lock handle.
7. Check again to see if the blade is 45° to the table. If not, repeat step 5.

Fig. JJ-1

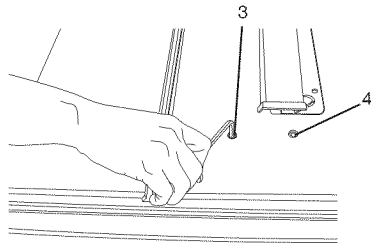

BLADE TILTING SCALE INDICATOR (Fig. KK)

NOTE: This is located on the top of the table, in front of the blade guard.

1. When the blade is positioned at 90°, adjust the blade tilting scale indicator to read 0° on the scale.
2. Remove the cover (1) by removing the two screws (2). Position the pointer over 0° and replace the cover and the screws.

NOTE: Make a trial cut on scrap wood before making critical cuts. Measure for accuracy.

Fig. KK

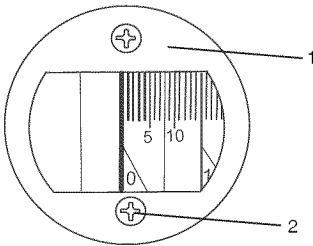

BLADE PARALLEL TO THE MITER GAUGE GROOVE (Fig. LL)

WARNING

This adjustment was made at the factory, but it should be rechecked and adjusted if necessary.

WARNING

To prevent personal injury:

- Always disconnect plug from the power source when making any adjustments.
- This adjustment must be correct or accurate cuts can not be made. Also inaccurate adjustment can result in kickback and serious personal injury.

1. Remove the safety switch key and unplug the saw.
2. Remove the blade guard for this procedure but reinstall and realign after adjustment.
3. Raise the blade to the highest position and set at the 0° angle (90° straight up).
4. Select and mark, with a felt tip marker, a blade tooth having a “right set” and rotate the blade so the marked tooth is 1/2 in. above the table.
5. Place the combination square base (1) into the right side miter gauge groove (2). (Fig. BB)
6. Adjust the rule so it touches the front marked tooth and lock ruler so it holds its position in the square assembly.
7. Rotate the blade bringing the marked tooth to the rear and about 1/2 in. above the blade.
8. Carefully slide the combination square to the rear until the ruler touches the marked tooth.
9. If the ruler touches the marked tooth at the front and rear position, no adjustment is needed at this time. If not or the base of the rule is no longer parallel with the edge of the miter gauge groove, perform adjustment procedure described in section ADDITIONAL BLADE ADJUSTMENTS on page 26.

Fig. LL

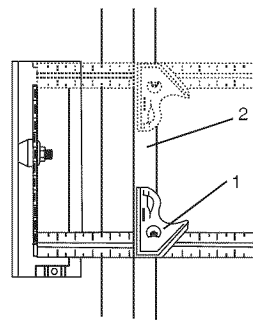

OPERATION

BASIC SAW OPERATIONS

RAISE THE BLADE (Fig. MM)

To raise or lower the blade, turn the blade elevation handwheel (1) to the desired blade height, and then tighten the bevel lock handle (2) to maintain the desired blade angle.

Fig. MM

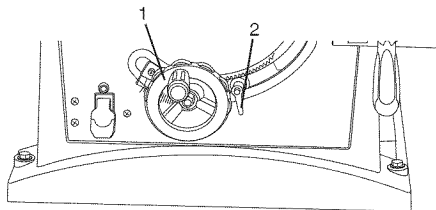

TILTING THE BLADE

Two methods are available for tilting the saw blade.

Rapid blade tilting:

Loosen the bevel lock handle (2), move the handwheel (1) to the desired angle, then tighten the bevel lock handle.

Fine adjustment blade tilting:

Loosen the bevel lock handle (2), push in the handwheel (1) and at the same time turn the handwheel (1) to tilt the saw blade. When the saw blade is at the desired angle, tighten the bevel lock handle (2).

ON/OFF SWITCH (Fig. NN)

The ON / OFF switch has a safety removal key. With the key removed from the switch, unauthorized and hazardous use by children and others is minimized.

1. To turn the saw ON, insert the safety switch key (1) into the slot in the switch (2). Move the switch upward to the ON position.

2. To turn the saw OFF, move the switch downward.
3. To lock the switch in the OFF position, grasp the end (or yellow part) of the safety switch key (1), and pull it out.
4. With the safety removal key removed, the switch will not operate.
5. If the safety removal key is removed while the saw is running, it can be turned OFF but cannot be restarted without inserting the switch key (1).

Fig. NN

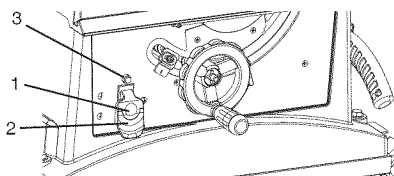

OVERLOAD PROTECTION (Fig. NN)

This saw has an overload reset button (3) that resets the motor after it shuts off due to overloading or low voltage. If the motor stops during operation, turn the ON / OFF switch to the OFF position. Wait about five minutes for the motor to cool, then push the reset button (3) and turn the switch to the ON position.

▲ WARNING

To avoid injury, the ON / OFF switch should be in the OFF position and the plug removed from the power source while the cool down takes place, to prevent accidental starting when the reset button is pushed. Overheating may be caused by misaligned parts or a dull blade or undersized extending cord. Inspect your saw for proper setup before using it again.

USING THE TABLE EXTENSION

(Fig. OO)

1. Release the extension cam locking levers (3) in the front and rear table positions.
2. Slide the extension (4) out until the correct measurement is displayed on the tube scale. The user sights the scale off the edge of the table.
3. Tighten all extension cam locking levers.

Fig. OO

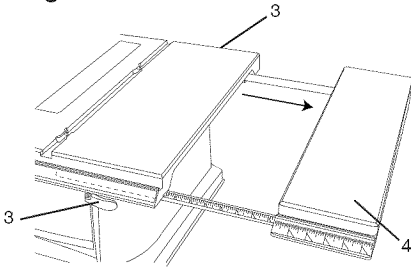

CUTTING OPERATIONS

There are two basic types of cuts: ripping and crosscutting. Ripping is cutting along the length and the grain of the workpiece. Crosscutting is cutting either across the width or across the grain of the workpiece. (It is not safe to rip or crosscut by freehand). Ripping requires the use of the rip fence, and crosscutting requires the miter gauge.

NEVER USE THE TWO AT THE SAME TIME.

NOTE: Apply a coat of automobile wax to the table. Wipe all parts thoroughly with a clean dry cloth. This will reduce friction when pushing the workpiece.

▲ WARNING

Before using the saw each time, check the following:

1. The blade is tightened to the arbor.
2. The bevel angle lock knob is tightened.
3. If ripping, make sure the fence is locked into position and is parallel to the miter gauge groove.
4. The blade guard is in place and working properly.
5. Safety glasses are worn.

The failure to adhere to these common safety rules, and those printed in the front of this manual, can greatly increase the likelihood of injury.

RIPPING (Fig. PP, QQ)

▲ WARNING

To prevent serious injury:

- Never use a miter gauge when ripping.
- Never use more than one rip fence during a single cut.
- Do not allow familiarity or frequent use of your table saw to cause careless mistakes. Remember that even a careless fraction of a second is enough to cause a severe injury.
- Keep both hands away from the blade and clear from the path of the blade.
- The workpiece must have a straight edge against the fence and must not be warped, twisted, or bowed when ripping.

1. Remove the miter gauge and store it in the "storage" compartment in the base of the saw.
2. Secure the rip fence to the table.
3. Raise the blade so it is about 1/8 in. higher than the top of the workpiece.
4. Place the workpiece flat on the table and against the fence. Keep the workpiece away from the blade.
5. Turn the saw ON and wait for the blade to come to full speed.
6. Slowly feed the workpiece into the blade by pushing forward only on the workpiece section (1) that will pass between the blade and the fence. (Fig. PP)
7. Keep your thumbs off the table top. When both of your thumbs touch the front edge of the table (2), finish the cut with a push stick (3). To make an additional push stick, use the pattern on page 47. (Fig. PP)

▲ WARNING

AVOID KICKBACK by pushing forward on the section of the workpiece that passes between the blade and the fence. Never perform any freehand operations.

Fig. PP

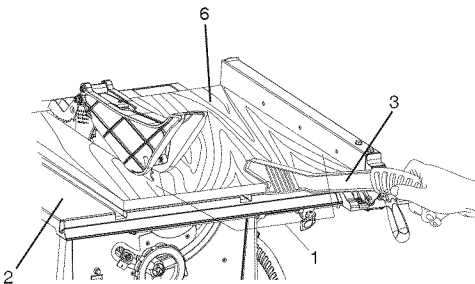

▲ WARNING

When width or rip narrower than 2 in. the push stick cannot be used because the blade guard will interfere. Use the auxiliary fence (4) and push block (5) as shown. (Fig. QQ)

Fig. QQ

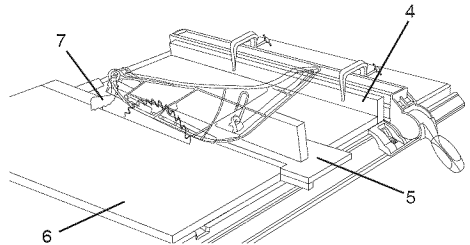

8. Continue pushing the workpiece (6) with the push stick (3-Fig. PP) or push block until it passes through the blade guard and clears the rear of the table. (Fig. QQ)
9. Never pull the piece back when the blade is turning. Turn the switch OFF. When the blade completely stops, you can then remove the workpiece.

▲ WARNING

Never attempt to pull the workpiece backwards during a cutting operation. This will cause kickback and serious injury to the user can occur. When the blade completely stops, raise the anti-kickback pawls (7) on each side of the riving knife and slide the workpiece out.

BEVEL RIPPING

This cut is the same as ripping except the blade bevel angle is set to an angle other than "0°".

RIPPING SMALL PIECES

To avoid injury from the blade contact, never make cuts narrower than 3/4 in. wide.

1. It is unsafe to rip small pieces.
Instead, rip a larger piece to obtain the size of the desired piece.
2. When a small width is to be ripped, your hand cannot be safely put between the blade and the rip fence, use push stick or push block to pass the workpiece completely through and past the blade.

HELPFUL DEVICES

In order to make some of cuts, it is necessary to use the devices like, push block, featherboard and auxiliary fence, which you can make yourself. Here are some templates for your reference.

FEATHERBOARD (FIG. RR, SS)

A featherboard is a device used to help control the workpiece by guiding it securely against the table or fence. Featherboards are especially useful when ripping small workpieces and for completing non-through cuts. The end is angled with a number of short kerfs to give a friction hold on the workpiece and locked in place on the table with C-clamps.

⚠ WARNING

Place the featherboard against the uncut portion of the workpiece to avoid kickback that could cause serious personal injury.

MAKE A FEATHERBOARD (Fig. RR)

Select a solid piece of lumber approximately 3/4 in thick, 4 in wide and 18 in long. To make a featherboard, cut one end of the lumber at 60 degrees, then cut 8 in-long slots 1/8 in apart on the angled end as shown in Fig. RR.

Fig. RR

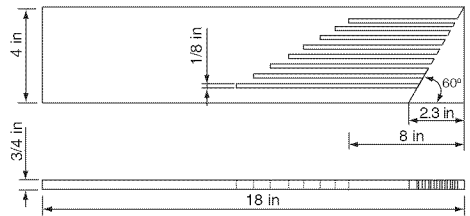

USE A FEATHERBOARD (Fig. SS)

1. Lower the saw blade (1).
2. Position the rip fence (2) to the desired adjustment and lock the rip fence.
3. Place the workpiece (3) against the fence and over the saw blade area.
4. Adjust the featherboard (4) to resist the workpiece forward of the blade.
5. Attached the C-clamps (5) to secure the featherboard to the edge of the table.

Fig. SS

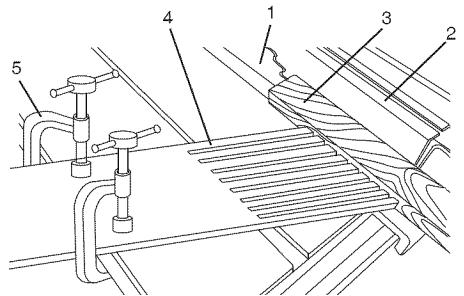

AUXILIARY FENCE (Fig. TT)

Making the base:

- Start with a piece of $\frac{3}{8}$ in. plywood at least 5- $\frac{1}{2}$ in. wide or wider and 21 in. long or longer.
- Cut the piece to shape and size shown:

Making the side:

- Start with a piece of $\frac{3}{4}$ in. hardwood at least 1- $\frac{3}{4}$ in. wide or wider and 21 in. long or longer.
- Cut the piece to shape and size shown:

Putting it together:

- Fasten the pieces together with glue and woodscrews.

WARNING

Make sure the screw heads do not stick out from the bottom of the base, they must be flush or recessed. The bottom must be flat and smooth enough to rest on the saw table without rocking.

Fig. TT

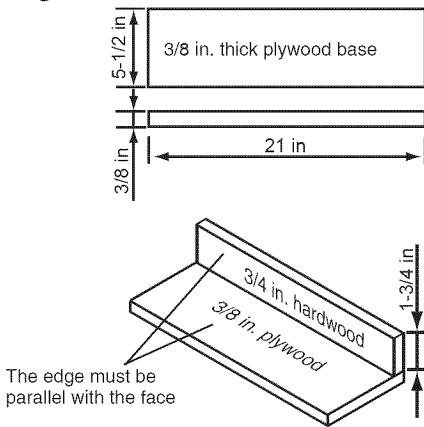

PUSH BLOCK

Use for ripping operation when the workpiece is too narrow to use a push stick. Always use a push block for rip widths less than 2 inches.

MAKE A PUSH BLOCK (Fig. UU)

Making the base:

- Start with a $\frac{3}{8}$ in. plywood at least 5- $\frac{1}{2}$ in. wide or wider and 12 in. long or longer.
- Cut the piece to shape and size as shown.

Making the handle:

- Start with a $\frac{3}{4}$ in. hardwood at least 5 in. wide or wider and 7 in. long or longer.
- Cut the piece to shape and size as shown.

Making the bracket:

- Start with a $\frac{3}{8}$ in. wood at least $\frac{3}{8}$ in. wide or wider and 2- $\frac{1}{2}$ in. long or longer.
- Cut the piece to shape and size as shown.

Putting it together:

- Fasten the base and handle together with glue and woodscrews.

WARNING

Make sure the screw heads do not stick out from the bottom of the base, they must be flush or recessed.

- Fasten the base and bracket together with glue.

WARNING

To avoid injury, do not use the screws to fasten the base and bracket.

Fig. UU

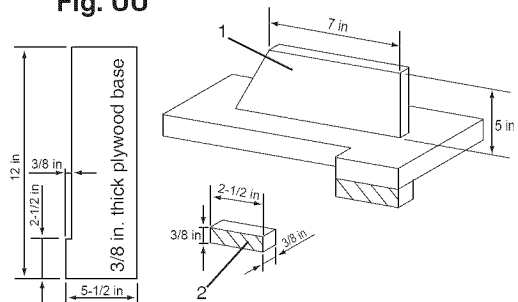

CROSSCUTTING (Fig. VV)

▲ WARNING

To prevent serious injury:

- Do not allow familiarity or frequent use of your table saw to cause careless mistakes. Remember that even a careless fraction of a second is enough to cause a severe injury.
 - Keep both hands away from the blade and the path of the blade.
 - Never attempt to pull the workpiece backwards during a cutting operation. This will cause kickback and serious injury to the user can occur.
1. Remove the rip fence and place the miter gauge in the miter gauge groove on the table.
 2. Adjust the blade height so that it is 1/8 in. higher than the top of the workpiece.
 3. Hold the workpiece firmly against the miter gauge with the blade path in line with the desired cut location. Move the workpiece to a 1 in. distance from the blade.
 4. Start the saw and wait for the blade (1) to come up to full speed. Never stand directly in line of the saw blade path, always stand to the side of the blade that you are cutting on.
 5. Keep the workpiece (2) against the face of the miter gauge (3) and flat against the table. Then slowly push the workpiece through the blade.
 6. Do not try to pull the workpiece back with the blade turning. Turn the switch OFF, and carefully slide the workpiece out when the blade has completely stopped.

▲ WARNING

Always position the larger surface of the workpiece on the table when crosscutting and/or bevel crosscutting to avoid instability.

Fig. VV

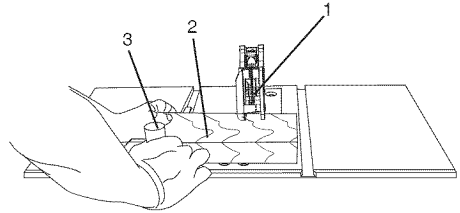

USING THE WOOD FACING ON THE MITER GAUGE (Fig. WW)

Slots are provided in the miter gauge for attaching an auxiliary facing (1) to make it easier to cut very long or short pieces. Select a suitable piece of smooth wood, drill two holes through it and attach it to the miter gauge with screws. Make sure the facing does not interfere with the proper operation of the saw blade guard. When cutting long workpieces, you can make a simple outfeed support by clamping a piece of plywood to a sawhorse.

Fig. WW

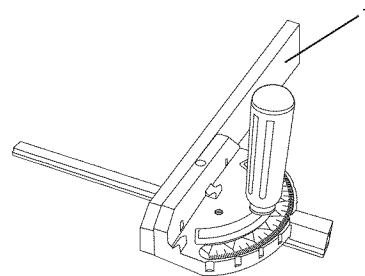

BEVEL CROSSCUTTING (Fig. XX)

0°~45° BLADE BEVEL & 90° MITER ANGLE This cutting operation is the same as crosscutting except the blade is at a bevel angle other than 0°.

WARNING

Always work to the right side of the blade during this type of cut. The miter gauge must be in the right side groove because the bevel angle may cause the blade guard to interfere with the cut if used on the left side groove.

1. Lower the blade to the down position.
2. Adjust the blade (1) to the desired angle, and tighten the blade bevel lock knob.
3. Tighten the miter lock handle (2) at 90°.
4. Hold workpiece (3) firmly against the face of the miter gauge throughout the cutting operation.

Fig. XX

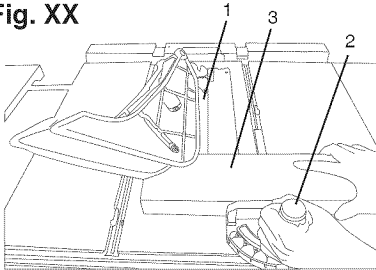

COMPOUND MITER CROSSCUTTING (Fig. YY) 0°~45° BLADE BEVEL & 0°~45° MITER ANGLE

This sawing operation combines a miter angle with a bevel angle.

WARNING

Always work to the right side of the blade during this type of cut. The miter gauge must be in the right side

groove because the bevel angle may cause the blade guard to interfere with the cut if used on the left side groove.

1. Set the miter gauge (3) to the desired angle.
2. Place the miter gauge in the right side groove of the table.
3. Set the blade (1) bevel to the desired bevel angle and tighten the blade bevel lock knob.
4. Hold workpiece (2) firmly against the face of the miter gauge throughout the cutting operation.

Fig. YY

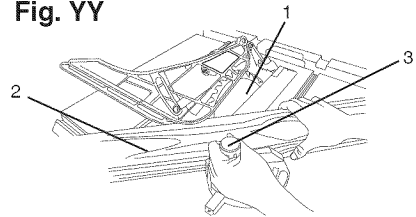

MITERING (Fig. ZZ) 0°~45° MITER ANGLE

This sawing operation is the same as crosscutting except the miter gauge is locked at an angle other than 90°.

1. Set the blade (1) to 0° bevel angle and tighten the blade bevel lock knob.
2. Set the miter gauge (3) at the desired miter angle and lock in position by tightening the miter gauge locking handle.
3. Hold the workpiece (2) firmly against the face of the miter gauge throughout the cutting operation.

Fig. ZZ

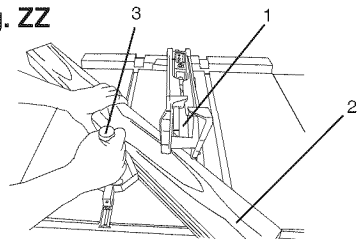

USING THE WOOD FACING ON THE RIP FENCE (Fig. aa)

When performing some special cutting operations, you can add a wood facing to either side of the rip fence (2).

1. Use a smooth straight 3/4 in. thick wood board (1) that is as long as the rip fence.
2. Attach the wood facing to the fence with wood screws (3) (not included) through the holes in the fence. A wood fence should be used when ripping material such as thin paneling to prevent the material from catching between the bottom of the fence and the table.

Fig. aa

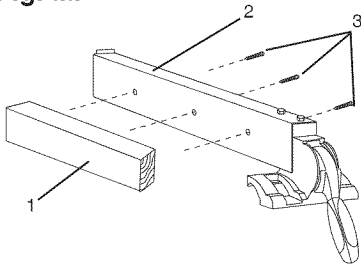

NON-THROUGH CUT (FIG. bb)

A non-through cut is used to cut grooves and rabbets in the workpiece without exposing the blade.

⚠ WARNING

- Only this type cut is made without installing the blade guard assembly, anti-kickback pawls assembly.
- To avoid injury from an accidental start, make sure the switch is in the OFF position and the plug is disconnected from the power source outlet.

- To avoid the risk of personal injury. Always use push block, auxiliary fence and featherboard when making non-through cut.

1. Before starting the table saw, lower the blade and riving knife assembly to the down position.
2. Remove the blade guard assembly and anti-kickback pawls assembly for non-through cut.
3. Use the featherboard (1) with C-clamps (3) to fasten the workpiece securely.
4. Mount the auxiliary fence (4) with C-clamps.
5. Use the push block (2) to move the workpiece.

NOTE:

- Mount the featherboard to table as shown, so the leading edges of featherboard will help workpiece complete cutting.

Fig. bb

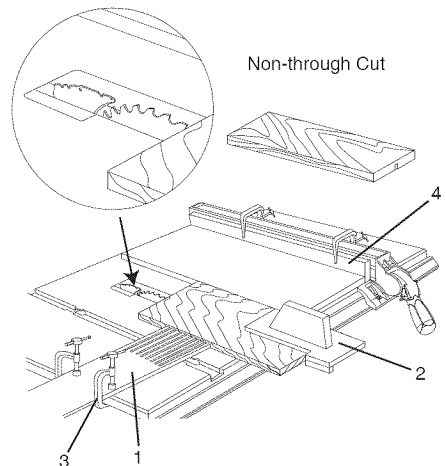

DADO CUTS (FIG. cc, dd)

▲ WARNING

- Only Stackable dado blades can be used on this saw.
- DO NOT use Adjustable or Wobble type dados.
- The maximum dado cut width is 1/2 in.

NOTE: An optional dado insert plate (part number 308K) is required for this procedure.

1. Remove the table insert, saw blade, anti-kickback pawl assembly, blade guard assembly and riving knife assembly for dado cuts ONLY. Reinstall and realign blade guard for all through-sawing operations. Install a dado not exceeding 6 in. in diameter and 1/2 in. in width
2. Install the dado table insert making sure that the rear of the insert is flush with the table. If the dado insert is not flush with the table, adjust the two bolts on the insert with a 4 mm hex wrench until it is parallel with the table.
3. Instructions for operating the dado is packed with the separately purchased dado set.
4. The arbor (1) on this saw restricts the maximum width of the cut to 1/2 in.
5. It is not necessary to install the outside flange (2) before threading the arbor nut (3) for the maximum 1/2 in. dado cuts. Make sure that the arbor nut (3) is tight, and that at least one thread of the arbor sticks out past the nut.

6. Use only the correct number of round outside blades and inside chippers as shown in the dado set's instruction manual. Blade/chippers must not exceed 1/2 in. total in width.

Fig. cc

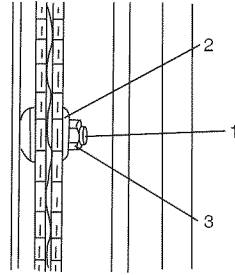

7. Check the saw to ensure that the dado will not strike the housing, insert, or motor when in operation.

▲ WARNING

For your own safety, always replace the blade, blade guard assembly, anti-kickback pawl assembly, riving knife assembly and table insert when you finished the dado operation.

Fig. dd

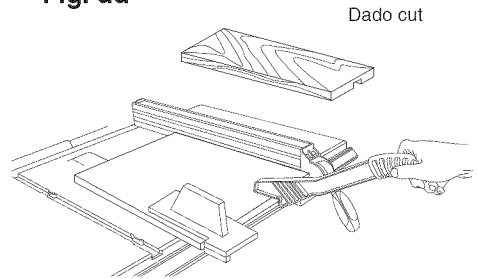

MAINTENANCE

MAINTAINING YOUR TABLE SAW

GENERAL MAINTENANCE

▲ WARNING

For your own safety, turn the switch OFF and remove the switch key. Remove the plug from the power source outlet before maintaining or lubricating your saw.

1. Clean out all sawdust that has accumulated inside the saw cabinet and the motor.
2. Polish the saw table with an automotive wax to keep it clean and to make it easier to slide the workpiece.
3. Clean cutting blades with pitch and gum remover.
4. A worn, cut, or damaged power cord should be replaced immediately.

▲ WARNING

All electrical or mechanical repairs should be attempted only by a trained repair technician. Contact customer service for assistance. Use only identical replacement parts. Any other parts may create a hazard.

5. Use liquid dishwashing detergent and water to clean all plastic parts.
NOTE: Certain cleaning chemicals can damage plastic parts.
6. Avoid use of cleaning chemicals or solvents, ammonia and household detergents containing ammonia.

BLADE RAISING AND TILTING MECHANISM (Fig. ee, ff)

After every five hours of operation, the blade raising mechanism and tilting mechanism should be checked for looseness, binding, or any other abnormalities.

1. With the saw disconnected from the power source, turn the saw upside down and pull up and push down on the motor unit.

2. Observe any movement of the motor mounting mechanism.
3. Loosen or tighten the four hex screws (1) by hex wrench for smooth operation. Only 1/8 turn at a time.
NOTE: Do not adjust the screw more than 1/2 turn as this may damage the mechanism.

Fig. ee

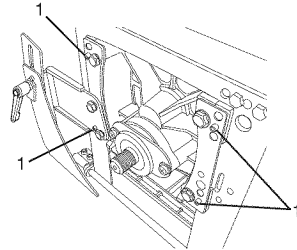

4. Place a small amount of dry lubricant on the bevel gear (2). The worm gear (3) must be kept clean and free of sawdust, gum, pitch, and other contaminants for smooth operations.

Fig. ff

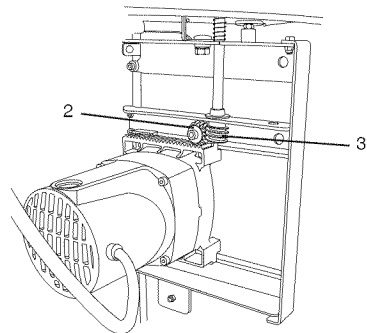

NOTE: If excessive looseness is observed in any part of the blade raising mechanism or tilting mechanism, take the complete unit to a Service Center.

LUBRICATION

All motor bearings are permanently lubricated at the factory and require no additional lubrication. On all mechanical parts of your table saw where a pivot or threaded rod are present, lubricate using graphite or silicone. These dry lubricants will not hold sawdust as would oil or grease.

REPLACING THE CARBON BRUSHES (Fig. gg, hh)

WARNING

Always disconnect the plug from the power source before inspecting the brushes.

The carbon brushes included with the unit will last approximately 50 hours of running time, or 10,000 ON/OFF cycles. Replace both carbon brushes when either has less than 1/4 in. length of carbon remaining, or if the spring or wire is damaged or burned.

1. Remove the blade guard, blade, rip fence, miter gauge and stand assembly from the table saw.
2. Lower the blade height to its minimum setting. This will make the brushes's location easier to access.
3. Place cardboard or an old blanket on the floor to protect the saw table surface.
4. Place the saw upside down on the protective material.
5. Tilt the blade elevation/tilting handwheel (1) to the 45° position.
6. Remove the black plastic cap (2) from the side of the motor (3).
7. Carefully remove the spring-loaded cap, and then pull out the brush (4).
8. Repeat step 6 and 7 for the other side of motor.
9. Place the new brush into the opening of motor, making sure the ears on the metal end of the assembly go in the same hole the carbon part fits into. Do not overtighten the plastic cap.
10. Carefully set the saw in a upright position on a clean level surface.
11. Replace the blade guard, blade,

rip fence, miter gauge and stand assembly to the table saw.

NOTE: To reinstall the same brushes, first make sure the brushes go back in the same sides they came out. This will avoid a break-in period that reduces motor performance and increases wear.

Fig. gg

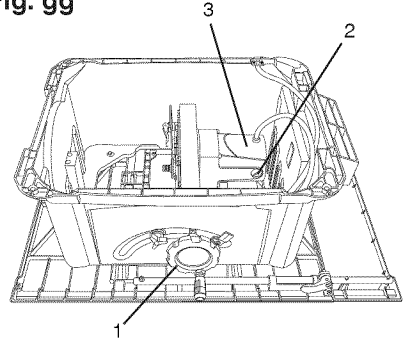
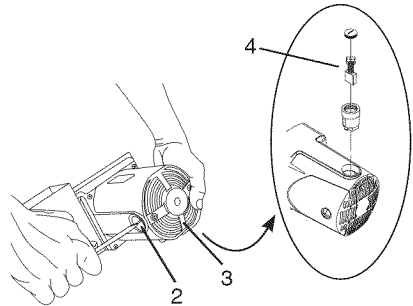

Fig. hh



CLEAN THE BLADE TILTING SCALE INDICATOR

NOTE: Occasionally cleaning the blade tilting scale indicator to remove dust may be necessary as a result of normal use. (Also see Fig. KK on page 32)

1. Release two screws on the cover set on the pointer. Clean the dust accumulated in the pointer and inside of the cover.
2. Position the pointer to 0°.
3. Replace the cover and tighten the two screws.

TROUBLESHOOTING GUIDE

WARNING

To avoid injury from accidental starting, always turn switch OFF and unplug the tool before moving, replacing the blade or making adjustments.

PROBLEM	POSSIBLE CAUSES	CORRECTIVE ACTION
Saw will not start.	<ol style="list-style-type: none"> 1. Saw is not plugged in. 2. Fuse blown or circuit breaker tripped. 3. Cord is damaged. 4. Debris in on/off switch 	<ol style="list-style-type: none"> 1. Plug in saw. 2. Replace fuse or reset circuit breaker. 3. Replace power cord. 4. Remove switch from saw and separate in half. Clean any debris accumulated within.
Does not make accurate 45° and 90° rip cuts.	<ol style="list-style-type: none"> 1. Positive stop not adjusted correctly. 2. Tilt angle pointer not set accurately. 	<ol style="list-style-type: none"> 1. Check blade with square and adjust positive stop. 2. Check blade with square and adjust to zero.
Material pinched blade when ripping.	<ol style="list-style-type: none"> 1. Rip fence not aligned with blade. 2. Warped wood, edge against fence is not straight. 	<ol style="list-style-type: none"> 1. Check and adjust rip fence. 2. Select another piece of wood.
Material binds on riving knife.	<ol style="list-style-type: none"> 1. Riving knife not aligned correctly with blade. 	<ol style="list-style-type: none"> 1. Check and align riving knife with blade.
Saw makes unsatisfactory cuts.	<ol style="list-style-type: none"> 1. Dull blade. 2. Blade mounted backwards. 3. Gum or pitch on blade. 4. Incorrect blade for work being done. 5. Gum or pitch on blade causing erratic feed. 	<ol style="list-style-type: none"> 1. Replace blade. 2. Turn the blade around. 3. Remove blade and clean with turpentine and coarse steel wool. 4. Change the blade. 5. Clean table with turpentine and steel wool.

⚠ WARNING

To avoid injury from accidental starting, always turn switch OFF and unplug the tool before moving, replacing the blade or making adjustments.

Material kicked back from blade.	<ol style="list-style-type: none"> 1. Rip fence out of adjustment. 2. Riving knife not aligned with blade. 3. Feeding stock without rip fence. 4. Riving knife not in place. 5. Dull blade. 6. The operator letting go of material before it is past saw blade. 7. Miter angle lock knob is not tight. 	<ol style="list-style-type: none"> 1. Align rip fence with miter gauge slot. 2. Align riving knife with blade. 3. Install and use rip fence. 4. Install and use riving knife. (with guard) 5. Replace blade. 6. Push material all the way past saw blade before releasing work. 7. Tighten knob.
Blade does not raise or tilt freely.	<ol style="list-style-type: none"> 1. Sawdust and dirt in elevation/tilting mechanisms. 	<ol style="list-style-type: none"> 1. Brush or blow out loose dust and dirt.
Blade does not come up to speed. Reset trips too easily.	<ol style="list-style-type: none"> 1. Extension cord too light or too long. 2. Low house voltage. 	<ol style="list-style-type: none"> 1. Replace with adequate size cord. 2. Contact your electric company.
Machine vibrates excessively.	<ol style="list-style-type: none"> 1. Saw not mounted securely to workbench. 2. Bench on uneven floor. 3. Damaged saw blade. 	<ol style="list-style-type: none"> 1. Tighten all mounting hardware. 2. Reposition on flat level surface. 3. Replace blade.
Does not make accurate 45° and 90° crosscuts.	<ol style="list-style-type: none"> 1. Miter gauge out of adjustment. 	<ol style="list-style-type: none"> 1. Adjust miter gauge.

PUSH STICK CONSTRUCTION

- Use good quality plywood or solid wood
- Use 1/2 in. or 3/4 in. material
- Push stick MUST be thinner than the width of material being cut

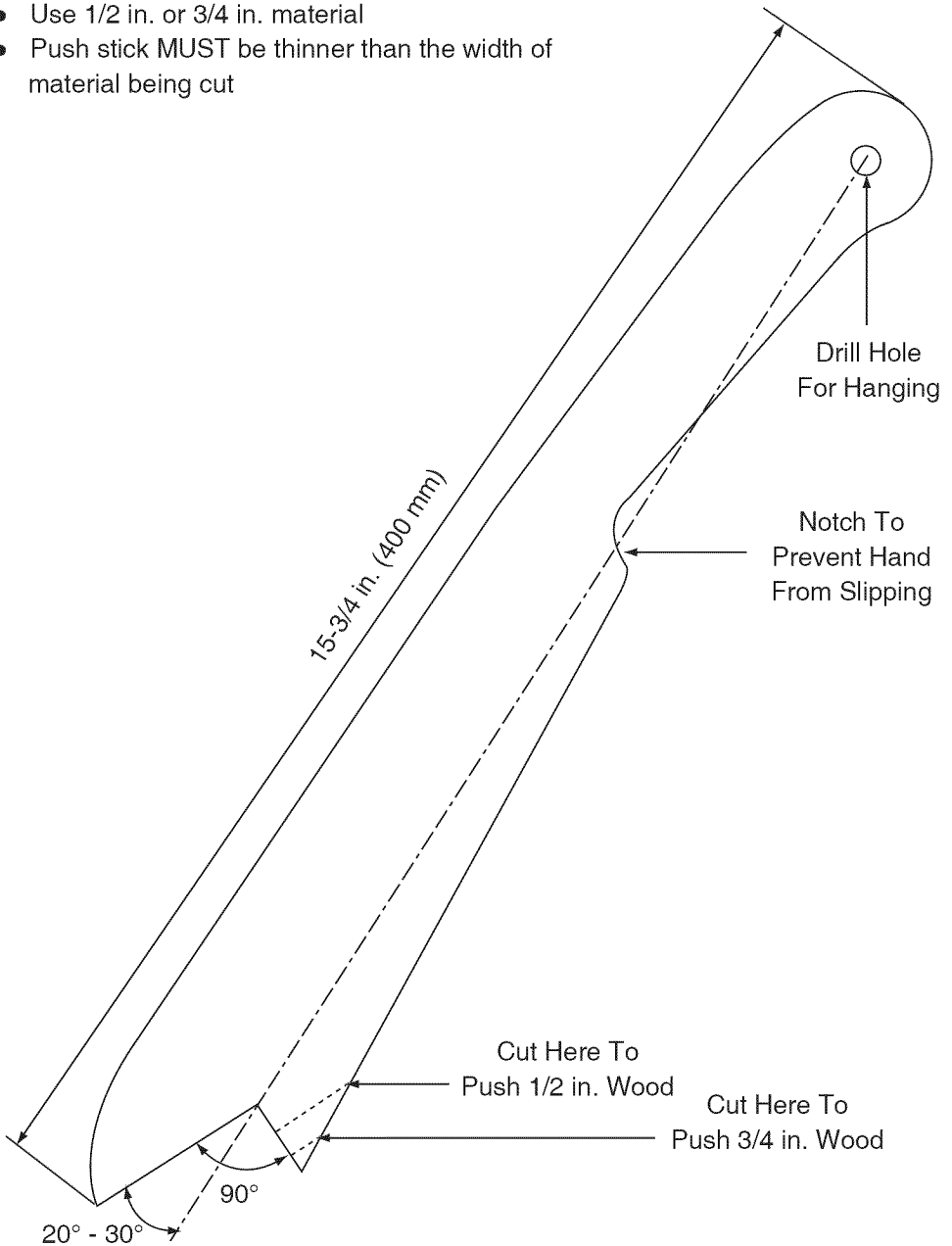



When servicing use only CRAFTSMAN replacement parts. Use of any other parts may create a HAZARD or cause product damage. Any attempt to repair or replace electrical parts on this Table Saw may create a HAZARD unless repair is done by a qualified service technician. Repair service is available at your nearest Sears Service Center.

PARTS LIST FOR TABLE SAW SCHEMATIC A

I.D.	Description	Size	QTY	I.D.	Description	Size	QTY
08VH	CORD CLAMP		1	2A4B	HEX. HD. SCREW AND WASHER	M5*0.8-1.6	7
0901	BUSH		1	2CB5	PUSH STICK		1
090QC	PLUNGER HOUSING		1	2E3K	CR. RE. ROUND WASHER HD. SCREW	M5*0.8-1.0	1
09JK	WRENCH		1	2ESV	COVER		1
0A4W8	SEGMENT GEAR		1	2ESX	NEEDLE POINTER		1
0B2B	NEEDLE POINTER		1	2ETB	ROLLING WHEEL		2
0B3R	WRENCH		1	2ETL	BAG-DUST		1
0B48	WARNING LABEL		1	2FH5	CUSHION		2
0B9P	CLAMP		1	2HT1	CR. RE. TRUSS HD. TAPPING SCREW	M5*12-8	4
0BA1	COMPRESSION SPRING		1	2JHQ	SLIDING BASE ASS'Y		2
0BA4	SPACER		1	2KLL	CR. RE. COUNT HD. SCREW	M4*0.7-1.0	2
0BA9	SPACER		1	2MSC	UPPER TUBE		2
0BAB	SHIM		1	2RVJ	CLAMPER BRACKET		1
0BAC	SET NUT		1	2RVM	GEAR		1
0BAE	ARBOR COLLAR		1	2KVP	SET FLATE		1
0J3F	HEX. WRENCH		1	2RVP	GUIDE CLAMP		4
0J4E	FLAT WASHER	φ6*13-1	2	2RVW	RETAINING CLIP		1
0J52	FLAT WASHER	φ16*25-1.2	1	2RW6	SET FLATE		1
0J5A	FLAT WASHER	φ5*16-2	1	25E0	ANCHOR PLATE		1
0J5C	FLAT WASHER	φ13.8*10-1	1	25JU	SPACER		1
0J6K	FLAT WASHER	φ6*30-4	1	2T6E	CLAMP ASS'Y		1
0J6T	FLAT WASHER	3/16*3/4-1/16	6	2TDD	COLLAR		1
0J74	FLAT WASHER	1/4*5/8-3/32	1	2TDD	WORM		1
0J72	FLAT WASHER	1/4*5/8-1/16	1	2TDL	FLAT WASHER		1
0J78	FLAT WASHER	1/4*1/2-3/32	1	2TLZ	POINTER BRACKET		1
0J7E	FLAT WASHER	5/16*11/16-1/16	1	2TUY	BLADE GUARD ASS'Y		1
0J8D	FLAT WASHER	3/8*3/4-5/64	1	2V3E	BLADE GUARD(RIGHT)		1
0JAE	EXTERNAL TOOTH LOCK WASHER	φ4	2	2V3F	BLADE GUARD(LEFT)		1
0JAF	EXTERNAL TOOTH LOCK WASHER	φ5	1	2X6N	SWITCH BOX ASS'Y		1
0J82	WAVE WASHER		1	2YEY	BODY		1
0J85	WAVE WASHER		1	2YEZ	BACK EXTENSION WING		1
0JD1	SPRING PIN		1	2YFO	SPLITTER		1
0JPA	HEX. HD. BOLT	M5*0.8-1.6	6	2YF4	RETAINING CLIP		1
0JPJ	HEX. HD. BOLT	M6*1.0-40	1	2YF7	FRONT UPPER TUBE_RIGHT		1
0JVV	HEX. SOC. HD. CAP BOLT	M6*1.0-16	1	2YF8	BACK UPPER TUBE_(RIGHT)		1
0JZY	HEX. SOC. TRUSS HD. SCREW	M6*1.0-12	1	2YFC	MITER SCALE ASS'Y		1
0K0X	HEX. HD. SCREW AND WASHER	M6*1.0-16	1	2YFD	BELT		1
0K0Y	HEX. HD. SCREW AND WASHER	M6*1.0-20	4	2YFN	RIGHT EXTENSION WING		1
0K3H	CR.RE. PAN HD. SCREW & WASHER	M6*1.0-12	2	2YFP	SUPPORT		2
0K5B	CR. RE. COUNT HD. SCREW	M6*1.0-12	4	2YGG	RETAINING CLIP		2
0K4T	CR.-RE. TRUSS HD. SCREW	M5*0.8-20	1	2YHG	DUST COLLECTOR		1
0K6Y	CR.-RE. TRUSS HD. SCREW	M4*0.7-1.0	2	2YHT	LOCKING HANDLE ASS'Y		1
0K7G	CR. RE. ROUND WASHER HD. SCREW	M5*0.8-12	4	2YHU	DUST PLATE COVER		1
0K8C	CR. RE. COUNT HD. TAPPING SCREW	M4*18-10	8	2YJO	SPACER		2
0KA4	CR.RE. PAN HD. TAPPING SCREW	M4*16-16	2	2YJA	MOTOR ASS'Y		1
0KA6	CR.RE. PAN HD. TAPPING SCREW	M5*12-10	4	2YKP	KICK BACK PAWL ASS'Y		1
0K8B	CR.RE. PAN HD. TAPPING SCREW	M5*16-16	2	2YLQ	ANGLE ROD		1
0KBQ	CR.RE. PAN HD. TAPPING SCREW	M5*16-10	1	2YNE	SPACER		1
0KC8	CR. RE. TRUSS HD. TAPPING SCREW	M4*16-16	3	2YS0	SET BOX		1
0KDR	CR. RE. PAN HD. SCREW	M5*0.8-10	2	2YS7	MITER GAUGE ASS'Y		1
0KDW	CR. RE. PAN HD. SCREW	M6*1.0-20	2	2YSG	CR. RE. COUNT HD. SCREW	M5*0.8-55	4
0KF7	CR. RE. PAN HD. SCREW	M4*0.7-1.2	2	2YSN	HAND WHEEL ASS'Y		1
0KJO	CAP HD. SQ.NECK BOLT	M6*1.0-16	1	2YTP	RIP FENCE ASS'Y		1
0KJN	CAP HD. SQ.NECK BOLT	M6*1.0-35	1	2YU2	BODY SHELL		1
0KMS	HEX. NUT	M6*1.0 T=5	3	2YU5	TABLE		1
0KQJ	CROWN NUT	M8*1.25 T=12.5	1	2YV5	HEIGHT REGULATING BOLT ASS'Y		1
0KQW	LOCK NUT	M5*0.8 T=5	5	2ZEJ	PLATE		1
0KQX	NUT	M6*1.0 T=6	2	2ZWK	CR. RE. PAN HD. SCREW	M6*1.0-70	1
0KRQ	SERRATED TOOTHED HEXAGON FLANGE NUT	M6*1.0 T=6	1	302W	FLAT WASHER	φ6*21-3	1
0KTK	STRAIN RELIEF		2	307Z	CROSS-RECESSED PAN HD PLAIN WASHER TAPPING SCREW	M5*0.8-10	6
0KUW	TERMINAL		1	308E	POWER CABLE ASS'Y		1
0KWU	LEAD WIRE ASS'Y		1	308H	INSERT	#23	1
0L5L	CIRCUIT BREAKER SWITCH		1	308Q	OPERATOR'S MANUAL		1
0LWC	ROCKER SWITCH		1	309H	WASHER		1
0S2Y	SLIDING BASE ASS'Y		1	30AT	LABEL		1
0S2Z	SLIDING BASE ASS'Y		1	30AU	SCALE		1
10K5	HEX. SOC. HD. CAP BOLT	M5*0.8-8	3	30AV	SCALE(RIGHT)		1
10LF	HEX. NUT	M6*1.0 T=4	2	30AW	SCALE(RIGHT)		1
147D	HEX. HD. BOLT	M5*0.8-25	4	30B2	CAUTION LABEL		1
212M	LEAD WIRE ASS'Y		1	30B3	POP-STICKER		1
25AP	HEX. SOC. HD. CAP BOLT	M6*1.0-25	1	30J3	LOCKING HANDLE ASS'Y		1
262S	POWER CORD CLAMP		2	30JR	HANDLE		1
275F	LOCATION SEAT		2	30JU	WARNING LABEL		2
27JR	HEX. SOC. SET SCREW	M5*0.8-6	4	30NM	SPECIAL BOLT		2
292S	BLADE ASS'Y		1				

10 IN. JOBSITE TABLE SAW

MODEL NO. 137.284630

SCHEMATIC A

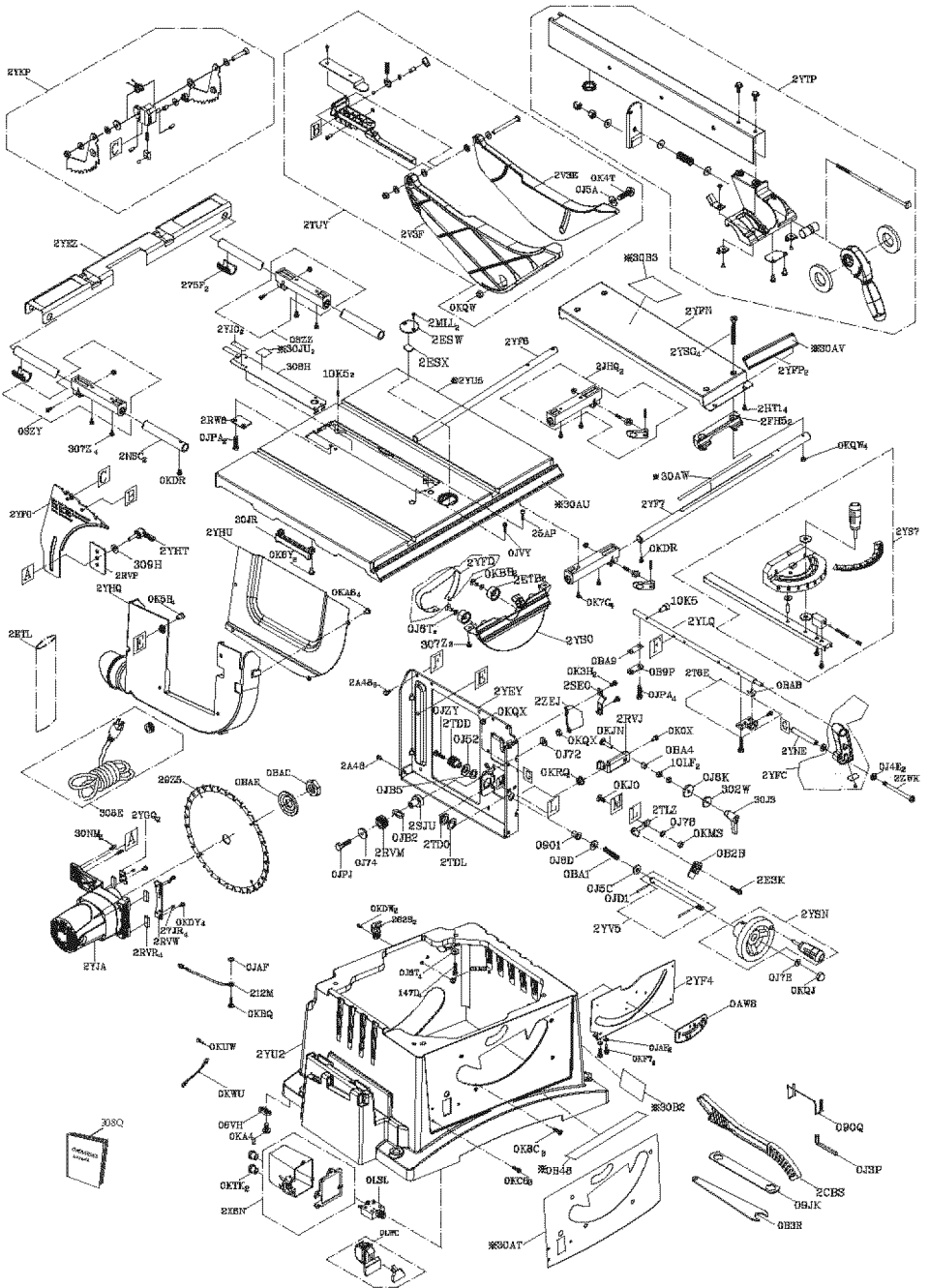

PARTS LIST FOR MOTOR

I.D.	Description	Size	QTY
3089	FIELD ASS'Y		1
0HX9	NEEDLE BEARING		1
0JX3	HEX. SOC. SET SCREW	M5*0.8-8	2
0KCN	CR. RE. PAN HEAD TAPPING & WASHER SCREW	M5*12-50	2
0KTK	STRAIN RELIEF		1
0QFE	BRUSH COVER		2
0QFF	CARBON BRUSH ASS'Y		2
0QFG	BRUSH HOLDER ASS'Y		2
145Y	CR. RE. PAN HD. SCREW & WASHER	M5*0.8-55	4
2DW9	WAVE WASHER		1
2RPP	FLOW GUIDE		1
2RRD	CUTTER SHAFT ASS'Y		1
2RWS	CR. RE. COUNTER-SUN HEAD SCREW	M5*0.8-10	2
2YF5	BRACKET		1
2YH8	MOTOR COVER		1
2YK4	ARMATURE ASS'Y		1
2YK7	LABEL		1

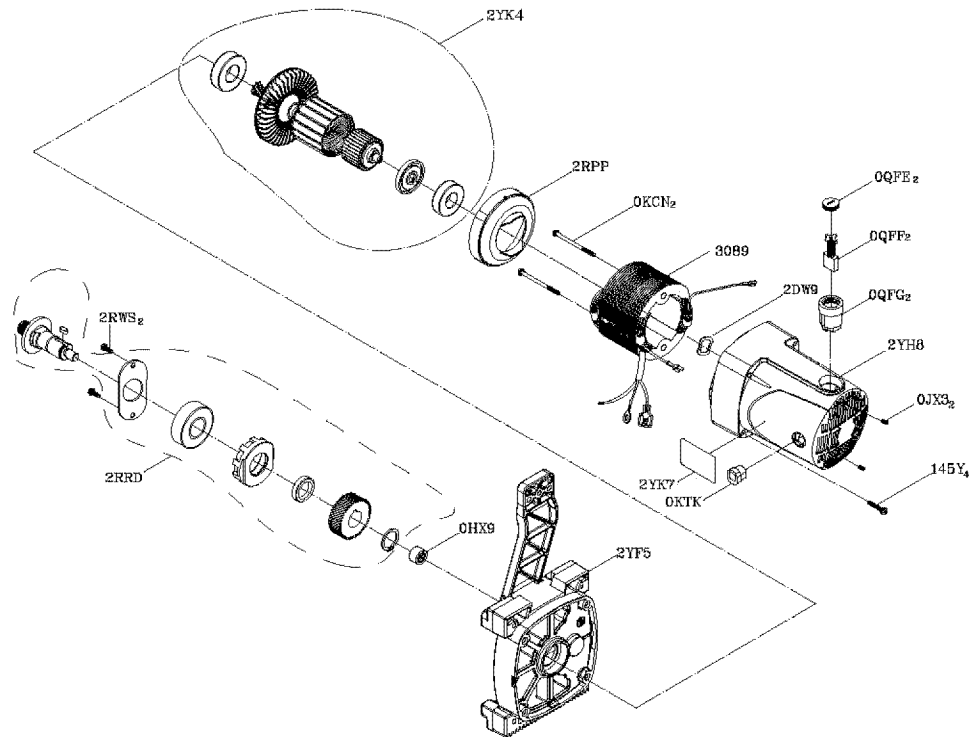

PARTS LIST FOR STAND

I.D.	Description	Size	QTY	I.D.	Description	Size	QTY
01AD	WING NUT		1	2A2R	LOCKING CABLE TIE		1
01AE	LEVELING PAD		1	2CFW	RUBBER FOOT BUSH		1
0J4E	FLAT WASHER	φ6*13-1	4	2CRF	HOOK		2
0J4R	FLAT WASHER	φ10*20-3	4	2LAL	BUSH		4
0J4W	FLAT WASHER	φ8.2*18-1.5	12	2VSP	CR.-RE. TRUSS HD. SCREW	M6*1.0-55	1
0J50	FLAT WASHER	φ6.3*15-4	3	2XGE	SLEEVE		2
0J5E	FLAT WASHER	φ8*15-1	2	2YFE	STIFFENER		1
0J5G	FLAT WASHER	φ8*18-1.5	4	2YFF	STIFFENER		1
0J80	WAVE WASHER		3	2YG4	BRACKET ASS'Y		1
0JP7	HEX. HD. BOLT	M10*1.5-105	2	2YG9	BOTTOM BRACKET ASS'Y_2		1
0JPS	HEX. HD. BOLT	M8*1.25-45	6	2YGD	BOTTOM BRACKET ASS'Y_1		1
0JPT	HEX. HD. BOLT	M8*1.25-60	1	2YHF	BOTTOM BRACKET		2
0JUH	HEX. SOC. HD. CAP BOLT	M6*1.0-10	2	2YHG	SLIDER		2
0K76	CR.-RE. TRUSS HD. SCREW	M6*1.0-45	2	2YHH	BUMPER		2
0K7F	CR. RE. ROUND WASHER HD. SCREW	M5*0.8-8	8	2YHK	COLLAR		2
0K7G	CR. RE. ROUND WASHER HD. SCREW	M5*0.8-12	4	2YHL	HANDLE BAR		1
0K7V	CR. RE. TRUSS HD. ROUND NECK SCREW	M6*1.0-14	3	2YHM	TORSION SPRING		1
0KDX	CR. RE. PAN HD. SCREW	M6*1.0-25	2	2YHP	GRAND STAND HANDLE		2
0KDZ	CR. RE. PAN HD. SCREW	M6*1.0-35	2	2YHT	LOCKING HANDLE ASS'Y		1
0KQX	NUT	M6*1.0T=6	6	2YUJ	COMPRESSION SPRING		2
0KQY	LOCK NUT	M8*1.25T=8	7	2Z2H	HOOK		1
10LF	HEX. NUT	M6*1.0T=4	3	309H	WASHER		1
270N	NUT CHUCK	M10*1.5T=8	2	30B0	CAUTION LABEL		1
28BR	HEX. HD. BOLT	M8*1.25-55	4	30B1	WARNING LABEL		1
28BU	FLOOR PLATE		1	30JT	ROLLING WHEEL		2

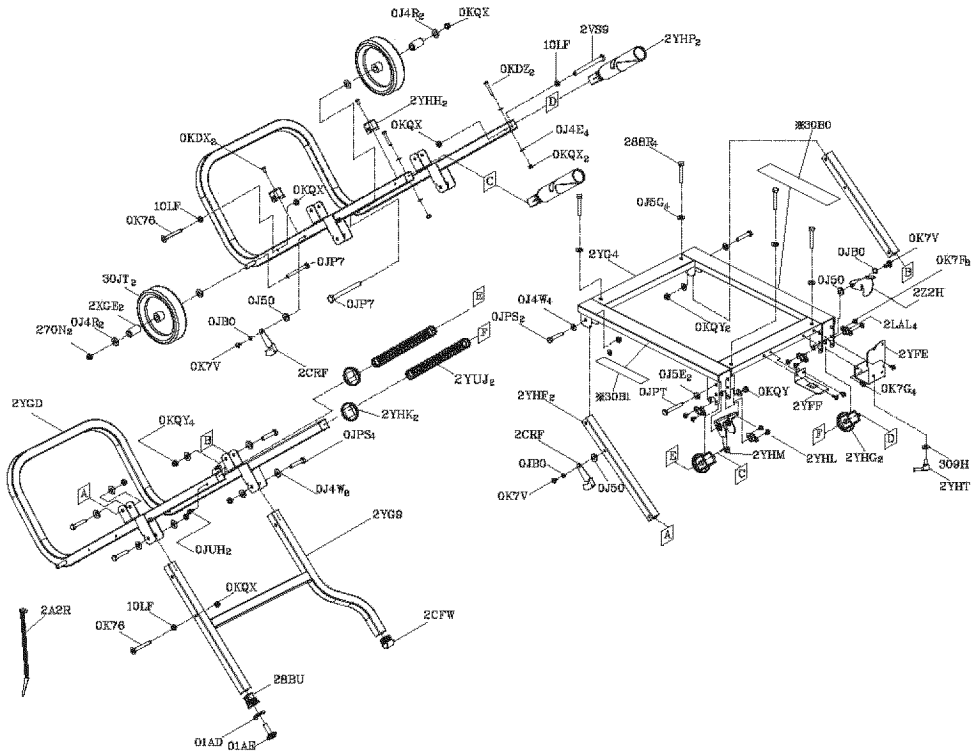

REPAIR PROTECTION AGREEMENTS

Congratulations on making a smart purchase. Your new Craftsman® product is designed and manufactured for years of dependable operation. But like all products, it may require repair from time to time. That's when having a Repair Protection Agreement can save you money and aggravation.

Here's what the Repair Protection Agreement* includes:

- ☑ **Expert service** by our 10,000 professional repair specialists
- ☑ **Unlimited service and no charge** for parts and labor on all covered repairs
- ☑ **Product replacement** up to \$1500 if your covered product can't be fixed
- ☑ **Discount of 10%** from regular price of service and related installed parts not covered by the agreement; also, 10% off regular price of preventive maintenance check
- ☑ **Fast help by phone** – we call it Rapid Resolution – phone support from a Sears representative. Think of us as a “talking owner's manual.”

Once you purchase the Repair Protection Agreement, a simple phone call is all that it takes for you to schedule service. You can call anytime day or night, or schedule a service appointment online.

The Repair Protection Agreement is a risk-free purchase. If you cancel for any reason during the product warranty period, we will provide a full refund. Or, a prorated refund anytime after the product warranty period expires. Purchase your Repair Protection Agreement today!

Some limitations and exclusions apply. For prices and additional information in the U.S.A. call 1-800-827-6655.

***Coverage in Canada varies on some items. For full details call Sears Canada at 1-800-361-6665.**

Sears Installation Service

For Sears professional installation of home appliances, garage door openers, water heaters, and other major home items, in the U.S.A. or Canada call **1-800-4-MY-HOME®**.

Get it fixed, at your home or ours!

Your Home

For expert troubleshooting and home solutions advice:

manage  home

www.managemyhome.com

For repair – **in your home** – of **all** major brand appliances, lawn and garden equipment, or heating and cooling systems, **no matter who made it, no matter who sold it!**

For the replacement parts, accessories and owner's manuals that you need to do-it-yourself.

For Sears professional installation of home appliances and items like garage door openers and water heaters.

1-800-4-MY-HOME® (1-800-469-4663)

Call anytime, day or night (U.S.A. and Canada)

www.sears.com www.sears.ca

Our Home

For repair of carry-in items like vacuums, lawn equipment, and electronics, call anytime for the location of your nearest

Sears Parts & Repair Service Center

1-800-488-1222 (U.S.A.) **1-800-469-4663** (Canada)

www.sears.com

www.sears.ca

To purchase a protection agreement on a product serviced by Sears:

1-800-827-6655 (U.S.A.)

1-800-361-6665 (Canada)

Para pedir servicio de reparación a domicilio, y para ordenar piezas:

1-888-SU-HOGAR®

(1-888-784-6427)

Au Canada pour service en français:

1-800-LE-FOYER^{MC}

(1-800-533-6937)

www.sears.ca

Sears