

CROSLEY

Use & Care Manual

Convertible Freezer/Refrigerator (with Low Temperature Freeze Protection)

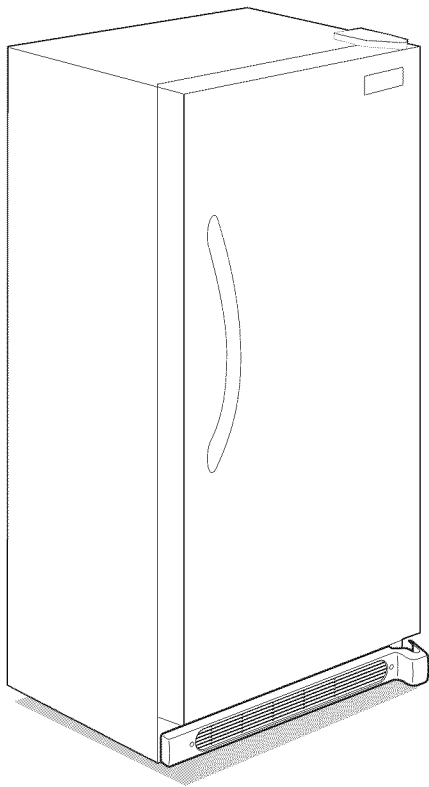

Product Registration 2

Energy Saving Ideas 2

Important Safety Instructions 2-3

First Steps..... 3 - 4

**Setting
the Temperature Control..... 4**

Freezer Optional Features..... 4 - 5

Care and Cleaning 5

Power Failure/Freezer Failure 6

Avoid Service Checklist..... 7 - 8

Warranty..... 9

READ AND SAVE THESE INSTRUCTIONS

P/N 297336200 (Jan 2010)

Product Registration

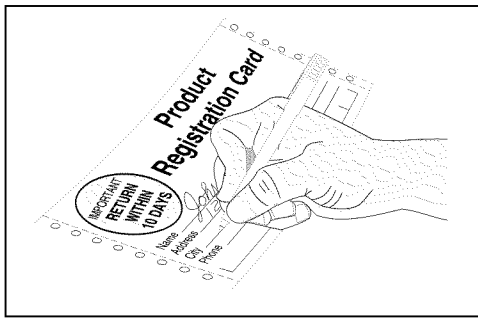

The information contained in this Use and Care Guide will instruct you on how to properly operate and care for your product. Please read through the information contained in your literature pack to learn more about your new freezer.

Record your Model and Serial Numbers

Record the model number and serial number of this freezer in the space provided below.

Model No. _____

Serial No. _____

Register Your Product

The self-addressed **PRODUCT REGISTRATION CARD** (shown above) should be filled in completely, signed and returned to Crosley Corporation.

This Use and Care Guide provides operating instructions for your model. Use your freezer only as instructed in this Use and Care Guide.

Energy Saving Ideas



- The freezer should be located in the coolest area of the room, away from heat producing appliances or heating ducts, and out of direct sunlight.

- Let hot foods cool to room temperature before placing in the freezer. Overloading the freezer forces the compressor to run longer. Foods that freeze too slowly may lose quality or spoil.
- Be sure to wrap foods properly and wipe containers dry before placing them in the freezer. This cuts down on frost build-up inside the freezer.
- Freezer shelves and baskets should not be lined with aluminum foil, wax paper, or paper toweling. Liners interfere with cold air circulation, making the freezer less efficient.
- Organize and label food to reduce door/lid openings and extended searches. Remove as many items as needed at one time, and close door/lid as soon as possible.

Important Safety Instructions

Read all instructions before using this freezer.

⚠ WARNING For your safety

Do not store or use gasoline or other flammable vapors and liquids in the vicinity of this unit or any other appliance. Read product labels for flammability and other warnings.

⚠ WARNING Child Safety

- Destroy carton, plastic bags, and any exterior wrapping material immediately after the freezer is unpacked. Children should never use these items for play. Cartons covered with rugs, bedspreads, plastic sheets or stretch wrap may become airtight chambers and can quickly cause suffocation.
- **A child might suffocate if he crawls into the freezer to hide or play. Remove the door/lid of the freezer when not in use, even if you plan to discard the freezer.** Many communities have laws requiring you to take this safety precaution.
- Remove or discard any spacers used to secure the shelves during shipping. Small objects are a choke hazard to children.

⚠ WARNING Risk of Child Entrapment

Child entrapment and suffocation are not problems of the past. Junked or abandoned refrigerators or freezers are still dangerous – even if they will sit for “just a few days”. If you are getting rid of your old refrigerator or freezer, please follow the instructions below to help prevent accidents:

- Remove the door/lid.
- Leave shelves in place so children may not easily climb inside.
- Have the refrigerant removed by a qualified technician.

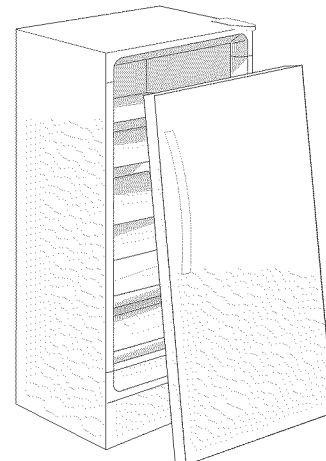

⚠️ WARNING Electrical Information

These guidelines must be followed to ensure that safety mechanisms in the design of this freezer will operate properly.

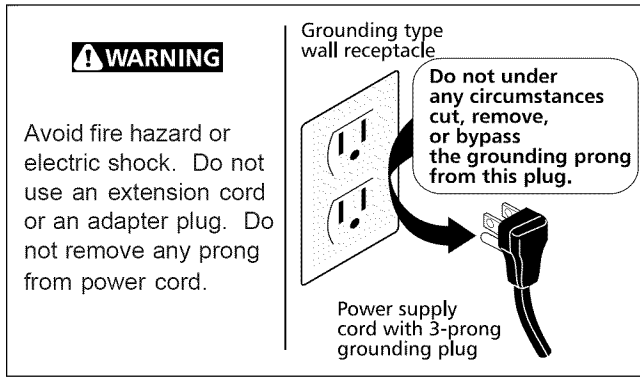

- **Refer to the serial plate for correct electrical rating.** The power cord of the freezer is equipped with a three-prong grounding plug for protection against shock hazards. It must be plugged directly into its own properly grounded three-prong receptacle, protected with a 15 amp time delay fuse or circuit breaker. The receptacle must be installed in accordance with the local codes and ordinances. Consult a qualified electrician. Receptacles with Ground Fault Circuit Interrupters (GFCI) are NOT RECOMMENDED. **DO NOT USE AN EXTENSION CORD OR AN ADAPTER PLUG.**
- If the voltage varies by 10 percent or more, freezer performance may be affected. Operating the freezer with insufficient power can damage the motor. Such damage is not covered under the warranty. If you suspect your voltage is high or low, consult your power company for testing.
- To prevent the freezer from being turned off accidentally, do not plug the unit into an outlet controlled by a wall switch or pull cord.
- Do not pinch, knot, or bend the power cord in any manner.

⚠️ WARNING Other Precautions

- To defrost, always unplug unit first.
- Never unplug the freezer by pulling on the power cord. Always grip the plug firmly and pull straight out from the receptacle.
- Turning the control to "OFF" turns off the compressor but does not disconnect power to other electrical components.

First Steps

Before starting the freezer, follow these important first steps.

Installation / Freezer Placement

- Choose a place that is near a grounded electrical outlet.
- The freezer should be located where surrounding temperature will not exceed 110°F (43°C). Temperatures of 32°F (0°C) and below will NOT affect freezer operation. Additional compressor heaters are not recommended.
- Allow space around the unit for good air circulation. Leave a 3 inch (75mm) space on all sides of the freezer for adequate circulation.

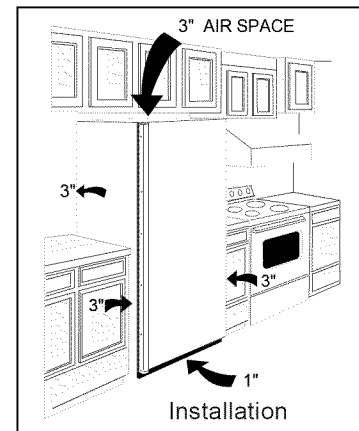

Leveling

The freezer must have all bottom corners resting firmly on a solid floor. The floor must be strong enough to support a fully loaded freezer. It is **VERY IMPORTANT** for your freezer to be level in order to function properly. If the freezer is not leveled during installation, the door/lid may be misaligned and not close or seal properly, causing cooling, frost or moisture problems.

To level Upright Units:

After discarding crating screws and wood base, use a carpenter's level to level the freezer from front to back. Adjust the plastic leveling feet in front, ½ bubble higher, so that the door closes easily when left halfway open.

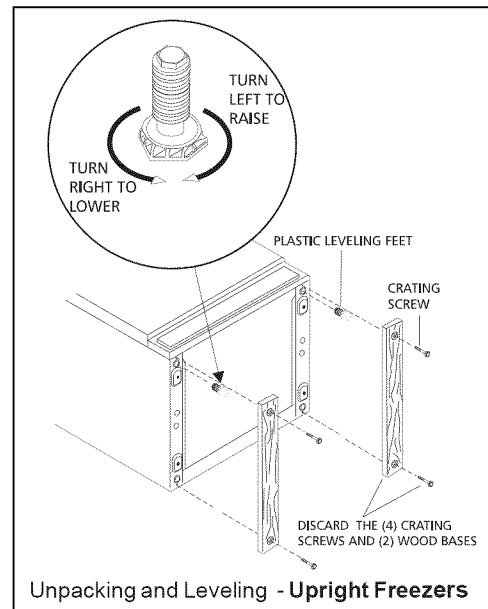

⚠️ CAUTION To allow door to close and seal properly, DO NOT let food packages extend past the front of shelves.

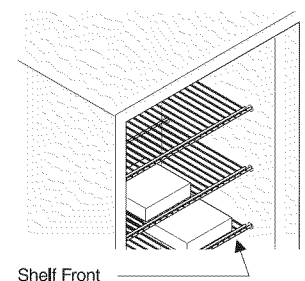

Door Removal (Upright Models)

- Unplug the unit
- Gently lay freezer on its back, on a rug or blanket.
- Remove two base screws and base panel.
- Remove the bottom hinge screws.
- Remove the plastic top hinge cover.
- Remove the screws from the top hinge.
- Remove the top hinge from the cabinet.
- Remove the door and bottom hinge from the cabinet.
- To replace door, reverse the above procedures and securely tighten all screws to prevent hinge slippage.

Setting the Temperature Control

Cool Down Period

- For safe food storage, allow four (4) hours for freezer to cool down completely. The freezer will run continuously for the first several hours. Foods that are already frozen may be placed in the freezer after the first few hours of operation. Unfrozen foods should **NOT** be loaded into the freezer until freezer has operated for four (4) hours.
- When loading freezer, freeze only three (3) pounds of fresh food per cubic foot of freezer space at one time. Distribute packages to be frozen evenly throughout the freezer. It is not necessary to turn the control knob to a colder setting while freezing food.

The convertible model can operate as either a freezer or a refrigerator. The selection is made using the rocker switch on the top of the panel as shown in Figure 1.

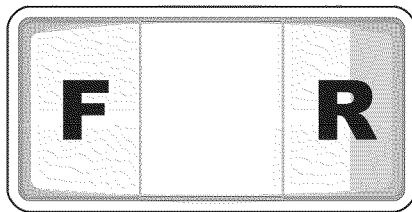

Convertible Switch
Figure 1

Pushing the switch to the "F" position will engage the freezer control on the left and pushing the switch to the "R" position will engage the refrigerator control on the right side. Positioning the switch in the middle position will disengage both freezer and refrigerator controls and disable all cooling functions. The light, if equipped, will still operate.

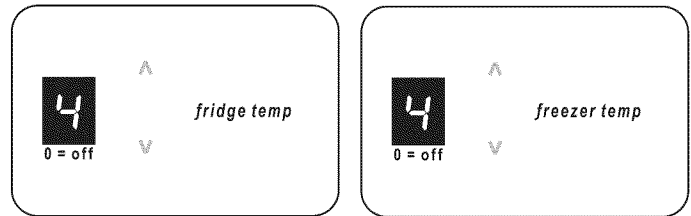

Convertible Controls
Figure 2

The temperature is factory preset to provide satisfactory food storage temperatures. To adjust the temperature setting, press UP button for warmer temperatures and the DOWN button for colder temperatures. Allow several hours for the temperature to stabilize between adjustments.

Automatic Freeze Control

When in the refrigerator mode the Freeze Control Feature will maintain proper interior refrigerator temperature even when the refrigerator is placed in an area where the surrounding temperature drops to 10°F (-12°C).

Freezer Optional Features

Your freezer may have some or all of the features listed below. Become familiar with these features and their use and care.

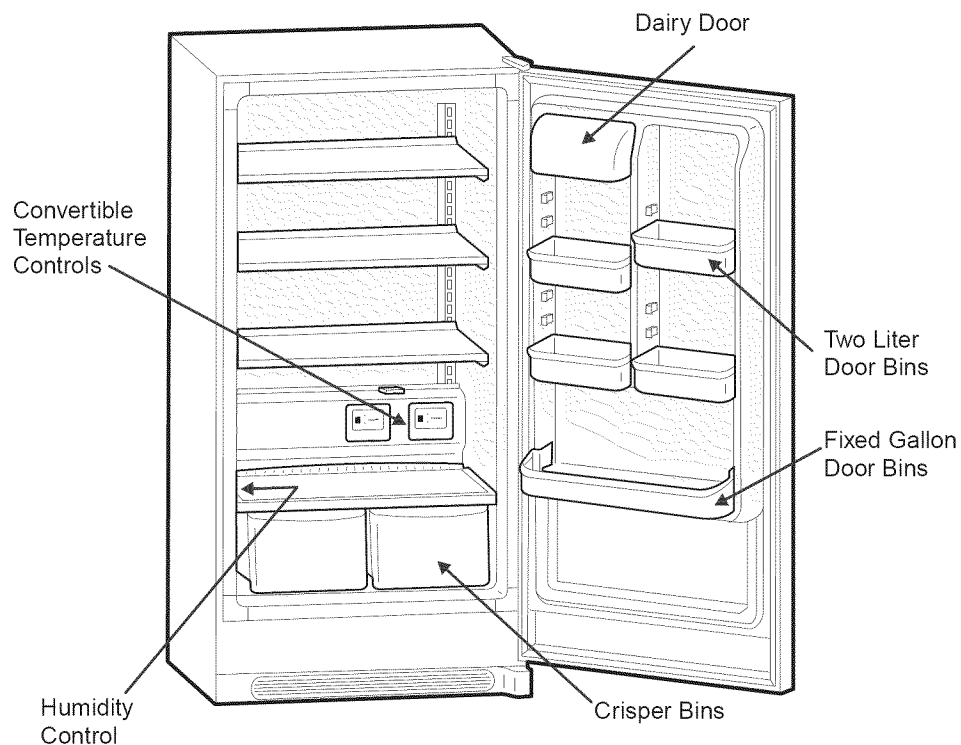

Adjustable Interior Shelves

Multi-position adjustable interior shelves can be moved to any position for larger or smaller packages. The shipping spacers that stabilize the shelves for shipping may be removed and discarded.

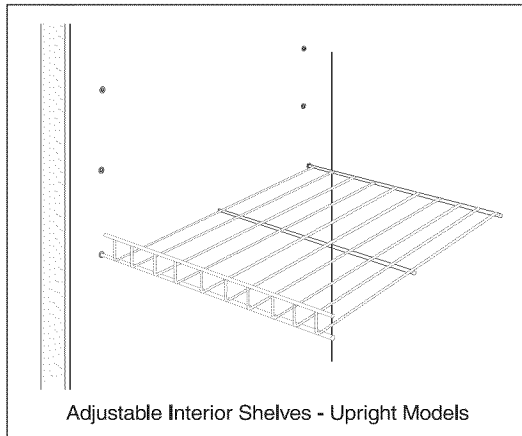

Door storage

Door bins, shelves, and racks are provided for convenient storage of jars, bottles, and cans. Frequently used items can be quickly selected.

Some models have door racks or bins that can accommodate gallon-sized plastic drink containers and economy-sized jars and containers.

The dairy compartment, which is warmer than the general food storage section, is intended for short term storage of cheese, spreads, or butter.

Adjustable door bins

Some models have adjustable door bins that can be moved to suit individual needs.

To move door bins

1. Lift bin straight up.
2. Remove bin.
3. Place bin in desired position.
4. Lower bin onto supports until locked in place.

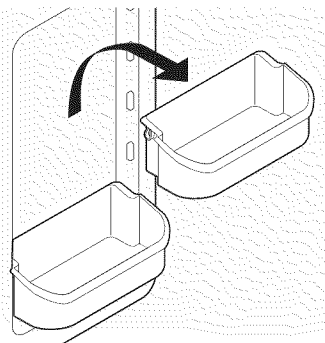

Crispers (some models)

The crispers, located under the bottom refrigerator shelf, are designed for storing fruits, vegetables, and other fresh produce. Wash items in clear water and remove excess water before placing them in the crispers. Items with strong odors or high moisture content should be wrapped before storing.

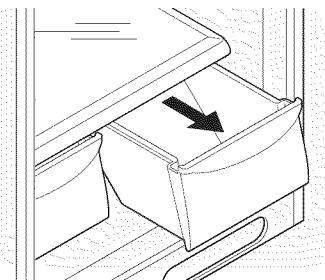

Crisper Drawer

Humidity Control (some models)

The Humidity Control, present on some models with crisper drawers, allows you to adjust the humidity within the crisper. This can extend the life of fresh vegetables that keep best in high humidity.

NOTE

Leafy vegetables keep best when stored with the Humidity Control set on **High Humidity**, or in a drawer without a Humidity Control. This keeps incoming air to a minimum and maintains maximum moisture content.

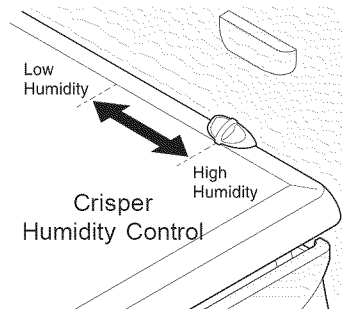

Care and Cleaning

- **Damp objects stick to cold metal surfaces. DO NOT touch interior metal surfaces with wet or damp hands.**
- **The freezer must be unplugged (to avoid electrical hazard) from power source when defrosting the unit.**

Convertible model is frost free and will defrost automatically, but should be cleaned occasionally.

Cleaning The Inside

After defrosting, wash inside surfaces of the freezer with a solution of two (2) tablespoons of baking soda in one (1) quart (1.136 liters) warm water. Rinse and dry. Wring excess water out of the sponge or cloth when cleaning in the area of the controls, or any electrical parts.

Wash the removable parts with the baking soda solution mentioned above, or mild detergent and warm water. Rinse and dry. **NEVER** use metallic scouring pads, brushes, abrasive cleaners or alkaline solutions on any surface. **DO NOT** wash removable parts in a dishwasher.

Cleaning The Outside

Wash the cabinet with warm water and mild liquid detergent. Rinse well and wipe dry with a clean soft cloth. Replace parts and food.

Do not use razor blades or other sharp instruments, which can scratch the freezer surface when removing adhesive labels. Any glue left from the tape can be removed with a mixture of warm water and mild detergent, or touch the residue with the sticky side of the tape already removed. **DO NOT REMOVE THE SERIAL PLATE.**

Power Failure / Freezer Failure

⚠ WARNING Risk of Child Entrapment

If leaving the freezer door/lid open while on vacation, make certain that children cannot get into the freezer and become entrapped. **DO NOT** open freezer door/lid unnecessarily if freezer is off for several hours.

Vacation and Moving Tips

Short Vacations:

- Leave the freezer operating during periods of non-use of less than three (3) weeks.

Long Vacations:

If the freezer will not be used for several months:

- Remove all food and unplug the power cord.
- Clean and dry the interior thoroughly.
- Leave the freezer door/lid open slightly, blocking it open if necessary, to prevent odor and mold growth.

Moving:

When moving the freezer, follow these guidelines to prevent damage:

- Disconnect the power cord plug from the wall outlet.
- Remove foods, then defrost, and clean the freezer.
- Secure all loose items such as base panel, baskets, and shelves by taping them securely in place to prevent damage.
- In the moving vehicle, secure freezer in an upright position to prevent movement. Also, protect outside of freezer with a blanket or similar item.

IF A POWER FAILURE OCCURS:

Frozen foods will stay frozen for at least 24 hours if the freezer is kept closed. If the power failure continues, pack seven or eight pounds of dry ice into the freezer every 24 hours. Look in the Yellow Pages under "Dry Ice", "Dairies", or "Ice Cream Manufacturers" for local dry ice suppliers. Always wear gloves and use caution when handling dry ice.

If the freezer has stopped operating, see the "Freezer does not run" section in the Avoid Service Checklist section of this use and care guide. If you cannot solve the problem, call an authorized service personnel immediately.

If the freezer remains off for several hours, follow the directions above for the use of dry ice during a power failure. If necessary, take the food to a local locker plant until the freezer is ready to operate. Look in the Yellow Pages under "Frozen Food Locker Plants".

AVOID SERVICE CHECKLIST	Before calling for service, review this list. It may save you time and expense. This list includes common occurrences that are not the result of defective workmanship or materials in this appliance.	
PROBLEM	CAUSE	CORRECTION
<i>FREEZER DOES NOT RUN.</i>		
Freezer does not run.	* Freezer is plugged into a circuit that has a ground fault interrupt.	* Use another circuit. If you are unsure about the outlet, have it checked by a certified technician.
	* Temperature control is in the "OFF" position.	* See Thermostat Setting.
	* Freezer may not be plugged in, or plug may be loose.	* Ensure plug is tightly pushed into outlet.
	* House fuse blown or tripped circuit breaker.	* Check/replace fuse with a 15 amp time delay fuse. Reset circuit breaker.
	* Power outage	* Check house lights. Call local Electric Company.
Freezer runs too much or too long.	* Room or outside weather is hot.	* It's normal for the freezer to work harder under these conditions.
	* Freezer has recently been disconnected for a period of time.	* It takes 24 hours for the freezer to cool down completely.
	* Large amount of warm or hot food have been stored recently.	* Warm food will cause freezer to run more until the desired temperature is reached.
	* Door/lid is opened too frequently or kept open too long.	* Warm air entering the freezer causes it to run more. Open the door/lid less often.
	* Freezer door/lid may be slightly open.	* See "Door/lid Problems".
	* Temperature control is set too low.	* Turn control knob to a warmer setting. Allow several hours for the temperature to stabilize.
	* Freezer gaskets are dirty, worn, cracked or poorly fitted.	* Clean or change gasket. Leaks in the door/lid seal will cause freezer to run longer in order to maintain desired temperature.
Interior freezer temperature is too cold.	* Temperature control is set too low.	* Turn control knob to a warmer setting. Allow several hours for the temperature to stabilize.
Interior freezer temperature is too warm.	* Temperature control is set too warm.	* Turn control knob to a colder setting. Allow several hours for the temperature to stabilize.
	* Door/lid is opened too frequently or kept open too long.	* Warm air entering the freezer causes it to run more. Open the door/lid less often.
	* Freezer door/lid may be slightly open.	* See "Door/lid Problems".
	* Large amount of warm or hot food have been stored recently.	* Wait until the freezer has had a chance to reach its selected temperature.
	* Freezer has recently been disconnected for a period of time.	* Freezer requires 24 hours to cool down completely.
Freezer external surface temperature is warm.	* The external freezer walls can be as much as 30°F warmer than room temperature.	* This is normal while the compressor works to transfer heat from inside the freezer cabinet.
<i>SOUND AND NOISE</i>		
Louder sound levels whenever freezer is on.	* Modern freezers have increased storage capacity and more stable temperatures. They require high efficiency compressors.	* This is normal. When the surrounding noise level is low, you might hear the compressor running while it cools the interior.
Louder sound levels when compressor comes on.	* Freezer operates at higher pressures during the start of the ON cycle.	* This is normal. Sound will level off or disappear as freezer continues to run.
Popping or cracking sound when compressor comes on.	* Metal parts undergo expansion and contraction, as in hot water pipes.	* This is normal. Sound will level off or disappear as freezer continues to run.

PROBLEM	CAUSE	CORRECTION
SOUND AND NOISE (Cont.)		
Bubbling or gurgling sound	* Refrigerant (used to cool freezer) is circulating throughout the	* This is normal.
Vibrating or rattling noise.	* Freezer is not level. It rocks on the floor when it is moved	* Level the freezer by putting wood or metal shims under part of the freezer.
	* Floor is uneven or weak.	* Ensure floor can adequately support freezer. Level the freezer by putting wood or metal shims under part of the freezer.
	* Freezer is touching the wall.	* Re-level freezer or move freezer slightly.
WATER / MOISTURE / FROST INSIDE FREEZER		
Moisture forms on inside freezer walls.	* Weather is hot and humid, which increases internal rate of frost build-up.	* This is normal.
	* Door is slightly open.	* Adjust leveling legs.
	* Door is kept open too long or is opened too frequently.	* Open the door less often.
WATER / MOISTURE / FROST OUTSIDE FREEZER		
Moisture forms on outside freezer walls.	* Door is slightly open.	* Adjust leveling legs.
ODOR IN FREEZER		
Odors in freezer.	* Interior needs to be cleaned.	* Clean interior with sponge, warm water, and baking soda.
	* Foods with strong odors are in the freezer.	* Cover the food tightly.
LIGHT BULB IS NOT ON		
Light bulb is not on.	* The fluorescent lamp or light bulb is burned out.	* See "Fluorescent Lamp" or "Interior Light" on Features Section.
	* No electric current is reaching the appliance.	* See "Freezer Does Not Run".

Major Appliance Warranty Information

Your appliance is covered by a one year limited warranty. For one year from your original date of purchase, Crosley will pay all costs for repairing or replacing any parts of this appliance that prove to be defective in materials or workmanship when such appliance is installed, used and maintained in accordance with the provided instructions.

*In addition to warranty shown above, ask your dealer about Crosley Extended Limited Warranty that comes to you at no extra charge for the 2nd through 10th years.

Exclusions **This warranty does not cover the following:**

1. Products with original serial numbers that have been removed, altered or cannot be readily determined.
2. Product that has been transferred from its original owner to another party or removed outside the USA or Canada.
3. Rust on the interior or exterior of the unit.
4. Products purchased "as-is" are not covered by this warranty.
5. Food loss due to any refrigerator or freezer failures.
6. Products used in a commercial setting.
7. Service calls which do not involve malfunction or defects in materials or workmanship, or for appliances not in ordinary household use or used other than in accordance with the provided instructions.
8. Service calls to correct the installation of your appliance or to instruct you how to use your appliance.
9. Expenses for making the appliance accessible for servicing, such as removal of trim, cupboards, shelves, etc., which are not a part of the appliance when it is shipped from the factory.
10. Service calls to repair or replace appliance light bulbs, air filters, water filters, other consumables, or knobs, handles, or other cosmetic parts.
11. Surcharges including, but not limited to, any after hour, weekend, or holiday service calls, tolls, ferry trip charges, or mileage expense for service calls to remote areas, including the state of Alaska.
12. Damages to the finish of appliance or home incurred during installation, including but not limited to floors, cabinets, walls, etc.
13. Damages caused by: services performed by unauthorized service companies; use of parts other than genuine Crosley parts or parts obtained from persons other than authorized service companies; or external causes such as abuse, misuse, inadequate power supply, accidents, fires, or acts of God.

DISCLAIMER OF IMPLIED WARRANTIES; LIMITATION OF REMEDIES

CUSTOMER'S SOLE AND EXCLUSIVE REMEDY UNDER THIS LIMITED WARRANTY SHALL BE PRODUCT REPAIR OR REPLACEMENT AS PROVIDED HEREIN. CLAIMS BASED ON IMPLIED WARRANTIES, INCLUDING WARRANTIES OF MERCHANTABILITY OR FITNESS FOR A PARTICULAR PURPOSE, ARE LIMITED TO ONE YEAR OR THE SHORTEST PERIOD ALLOWED BY LAW, BUT NOT LESS THAN ONE YEAR. CROSLLEY SHALL NOT BE LIABLE FOR CONSEQUENTIAL OR INCIDENTAL DAMAGES SUCH AS PROPERTY DAMAGE AND INCIDENTAL EXPENSES RESULTING FROM ANY BREACH OF THIS WRITTEN LIMITED WARRANTY OR ANY IMPLIED WARRANTY. SOME STATES AND PROVINCES DO NOT ALLOW THE EXCLUSION OR LIMITATION OF INCIDENTAL OR CONSEQUENTIAL DAMAGES, OR LIMITATIONS ON THE DURATION OF IMPLIED WARRANTIES, SO THESE LIMITATIONS OR EXCLUSIONS MAY NOT APPLY TO YOU. THIS WRITTEN WARRANTY GIVES YOU SPECIFIC LEGAL RIGHTS. YOU MAY ALSO HAVE OTHER RIGHTS THAT VARY FROM STATE TO STATE.

If You Need Service Keep your receipt, delivery slip, or some other appropriate payment record to establish the warranty period should service be required. If service is performed, it is in your best interest to obtain and keep all receipts. Service under this warranty must be obtained by contacting Crosley at the addresses or phone numbers below.

This warranty only applies in the USA and Canada. Your appliance is warranted by Crosley Corporation. Crosley authorizes no person to change or add to any obligations under this warranty. Obligations for service and parts under this warranty must be performed by Crosley or an authorized service company. Product features or specifications as described or illustrated are subject to change without notice.

FOR WARRANTY INFORMATION CONTACT:

USA 800-944-9044
Canada 800-265-8352



FOR PRODUCT INFORMATION CONTACT:

336-761-1212
Crosley Corporation
111 Cloverleaf Dr.
Suite 200
Winston-Salem, NC 27103
www.crosley.com