

OPERATOR'S MANUAL

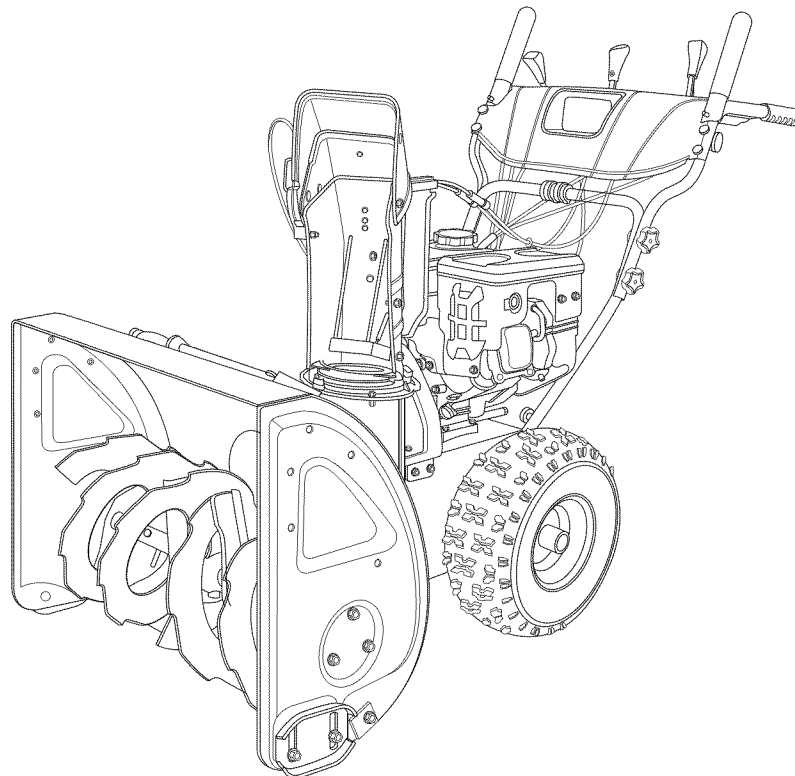

Snow Joe Pro Dual Stage Gas Snow Thrower Series Models **SJ905/906/907/908/909**

⚠ WARNING

Read and follow all safety rules and instructions in this manual before attempting to operate this machine. Failure to comply with these instructions may result in personal injury. Save these instructions.

This unit is equipped with an internal combustion engine and may spark resulting in fire or explosion if used near combustible material or fluid. Only use when the engine's exhaust system is equipped with a spark arrester meeting applicable local or state laws (if any). The spark arrester shall be maintained in effective working order by operator.

SNOW JOE LLC, 86 EXECUTIVE AVE, EDISON, NJ 08817
www.snowjoe.com

Form NO. 7SJ900-800

Table of Contents

Safety.....	3
Assembly.....	7
Controls and Features.....	9
Operation.....	10
Adjustments & Maintenance.....	13
Troubleshooting.....	16
Replacement Parts.....	18
Warranty.....	19

Record Product Information

Model and Serial Numbers

When contacting the company, reordering parts, or arranging service from an authorized dealer, you will need to provide the model and serial numbers, which can be found on the bottom of the engine mount. Copy these numbers into the space provided to the right.

Please record the following numbers from the serial number decal.

Model #:
S J 9
Serial #:

Customer Support

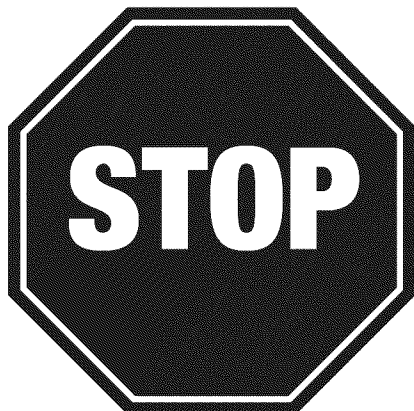

DO NOT return this SNOW JOE/SUN JOE product to the Retailer!

Please call our customer service team for assistance at **866-766-9563 (866-SNOW-JOE)** Or visit **www.snowjoe.com** and click on **'Customer Service'**.

Our service representatives and technicians will be happy to assist you with any questions you may have. Our office hours are 9am to 5:30 pm Eastern Time.

Thank you for choosing our products!

Introduction

Thank you for purchasing a Snow Joe Snow Thrower. This machine has been engineered to provide excellent performance when properly operated and maintained.

It is important that you read, and understand, the safety, operation and maintenance information before using the snow thrower. Save this manual for future reference.

1. Safety

⚠ WARNING

This symbol indicates important safety instructions. Failure to observe and follow these instructions may result in personal injury or property damage. Read and follow all instructions in this manual before attempting to operate this machine.

⚠ WARNING

CALIFORNIA PROPOSITION 65

Engine Exhaust, some of its constituents, and certain vehicle components contain or emit chemicals known to State of California to cause cancer and birth defector or other reproductive harm.

⚠ DANGER

Carelessness, mishandling or error on part of the operator may result bodily injury (e.g.: amputation, projectile impact), or death. The snow thrower must be operated according to the warnings and guidelines in this manual.

Training

⚠ WARNING

Use of this machine by an untrained individual may result in serious injury or death. Only individual's who have read, understand and follow the warnings and instructions in this manual shall operate this machine.

Follow these rules:

- Read, understand and follow all instructions on the snow thrower and in the manual(s) before attempting to assemble and operate. Save this manual for reference and ordering replacement parts.
- Never allow children under 14 years old to operate this machine. Children 14 years old and over should be trained and supervised by an adult who understands the operation of the snow thrower.
- Never allow an untrained individual to operate the snow thrower.
- Understand the function of all the controls and their proper operation. Know how to stop the machine and disengage them quickly.
- Always plan your snow-throwing pattern to avoid discharge of material toward people, pets and property. Thrown objects can cause serious personal injury.
- Keep people, pets and property at least 75 feet from the snow thrower while it is in operation. Stop the snow thrower if people or pets enter the discharge area.
- Always observe the surface conditions in order to avoid slipping or falling, especially when operating in reverse.
- provides sure footing.
- Use a grounded three-wire extension cord and receptacle for units that have electric start engines. The electric starter is equipped with a grounded three-wire power cord and plug and is designed to operate on 120 volt AC household current. It must be used with a properly grounded three-prong receptacle at all times to avoid the possibility of electric shock. Follow all instructions carefully prior to operating the electric starter. **DO NOT** use electric starter in rain.
- Adjust collector housing height to clear gravel or crushed rock surfaces. **Do not** attempt to make any adjustments while the engine is running, except if specifically recommended in this operator's manual.
- Before starting the engine, disengage all clutch levers.
- Let the engine adjust to the outdoor temperature before starting to clear snow.

Gasoline is extremely flammable and the vapors are explosive which may result in serious injury or property damage. Use extreme care when handling gasoline, avoid spilling gasoline on yourself or your clothes. Wash your skin and change your clothes immediately if gasoline spills on them.

Follow these rules:

- Extinguish all cigarettes, cigars, pipes and other sources of ignition when around gasoline.
- Always use an approved gasoline container.
- Never fill containers inside a vehicle or on a truck or trailer bed with a plastic liner. Always place containers on the ground away from your vehicle before filling.
- Always fuel machine outdoors, **never** indoors.
- Do not remove the gas cap or add fuel while the engine is hot or running. Allow engine to cool at least two minutes before refueling.

Preparation

Always inspect the area where the show thrower is to be used. Remove all objects (e.g.: doormats, newspapers, stones and foreign objects) that could be thrown by the auger/impeller or cause the operator to trip.

- Thrown objects can cause serious injury to the eyes and exposed body. Always wear safety glasses or eye shields during operation and while performing an adjustment or repair.
- Always operate wearing adequate winter outer garments. **Do not** wear jewelry, long scarves or other loose clothing, which could become entangled in moving parts. Wear footwear that

- Keep the nozzle in contact with the rim of the fuel tank or container opening at all times until fueling is complete. Do not use the nozzle lock-open device.
- Provide space for fuel expansion. Fill the fuel tank to no more than 1/2 inch below bottom of filler neck. Do not overfill fuel tank.
- Wipe off gasoline that spills on the engine and snow thrower body. Move machine to another location and wait 5 minutes before starting the engine.
- Always replace gasoline cap and tighten securely.
- Allow machine to cool at least 5 minutes before storing.
- Never store the machine or fuel container inside where there is an open flame, spark or pilot light (e.g.: furnace, water heater, space heater, clothes dryer, etc.).

Operation

Follow these rules:

- Do not operate machine while under the influence of alcohol or drugs.
- Keep all safety devices in place and working. Do not operate with a missing or damaged chute assembly. Bypassing the auger/impeller control makes the snow thrower unsafe and may cause personal injury.
- When manually starting the engine, pull cord slowly until resistance is felt, then pull rapidly. Rapid retraction of the starter cord (kickback) will pull hand and arm towards engine faster than you can let go. Broken bones, fractures, bruises or sprains could result.
- Ensure the controls operate easily in both directions and automatically return to the disengaged position when released.
- Contact with the rotating parts can amputate hands and feet. Do not put hands or feet near rotating parts, in the auger/impeller housing or chute assembly.
- Engine exhaust contains carbon monoxide, an odorless and deadly gas. Always have the snow thrower outdoors, or ventilated area, when running the engine.
- Muffler and engine become hot and can cause a burn. Do not touch.
- Plan your snow-throwing pattern to avoid discharge towards people or property (e.g.: windows, cars etc.). Do not direct discharge at children, bystanders and pets or allow anyone in front of the machine.
- Exercise caution when changing direction, operating on slopes or crossing gravel surface. Always look for hidden obstacles or hazards.
- Only operate the snow thrower when there is good visibility or light. Always watch your footing and keep a firm hold on the handles. Walk don't run!
- Do not operate the snow thrower at high transport speeds on slippery surfaces. Check your footing when in reverse (Applies to Dual Stage Models).
- Do not overload machine capacity by attempting to clear snow at too fast of a rate.
- Stop the engine and disengage all controls before you leave the operating position (behind the handles) to unclog the chute assembly, make any adjustments or inspections. Wait until the auger/impeller comes to a complete stop.
- Do not put your hand in the discharge or collector openings. Always use a cleanout tool to unclog the discharge opening. Do not unclog chute assembly while engine is running. Shut off engine and remain behind handles until all moving parts have stopped before unclogging.
- If the snow thrower should start to vibrate abnormally, stop the engine, disconnect the spark plug wire and ground it against the engine. Inspect thoroughly for damage.

- When transporting or not in use disengage the power to the auger/impeller.
- Use only attachments and accessories approved by the manufacturer (e.g. wheel weights, tire chains, cabs etc.).
- Always use care and good judgment when you have a situation that is not covered in this manual. If unsure, always contact the distributors where you bought the snow thrower or your nearest service location before proceeding.

Maintenance and Storage

Follow these rules:

- Maintain or replace safety and instruction labels.
- Disengage all controls, stop the engine and wait until the auger/impeller comes to a complete stop before cleaning, repairing or inspecting the snow thrower.
- Disconnect the spark wire and ground against the engine to prevent unintended starting. **Do not** crank engine with spark plug removed.
- Regularly check the following:
 - Accumulation of debris around the muffler could cause a fire. Inspect and clean before every use.
 - Safety devices are operating properly. **Do not** tamper with or adjust safety devices. **Do not** change the engine governor setting or over-speed the engine. The governor controls the maximum safe operating speed of the engine.
 - Bolts and screws for proper tightness. Visually inspect machine for any damage and the snow thrower is in safe working condition.
 - Inspect snow thrower shave plates and skid shoes for wear and damage. Replace with original equipment manufacturer's (OEM) parts only. Replacement parts that do not meet the original equipment specifications may lead to improper performance and compromise safety.
 - Clutch controls. Verify they engage and disengage properly and adjust, if necessary.
 - Check fuel line, tank cap, and fittings frequently for cracks or leaks. Replace if necessary.
- Prior to storing, run the snow thrower a few minutes to clear snow from machine and prevent freeze up of auger/impeller.
- **Do not** store the machine or fuel container inside where there is an open flame, spark or pilot light such as a water heater, furnace, clothes dryer etc.
- Observe proper disposal laws and regulations for gas, oil, etc. to protect the environment
- Always refer to the operator's manual for proper instructions on off-season storage.
- At the end of the *Average Useful Life* have the machine inspected annually to ensure that all mechanical and safety systems are working properly and not worn excessively. Failure to do so can result in accidents, injuries and death. **Note:** According to Consumer Products Safety Commission (CPSC) and the U.S. Environmental Protection Agency (EPA), this product has an Average Useful Life of seven (7) years, or 60 hours of operation)

Engine Modification

Tampering with the governor setting can lead to a runaway engine and cause it to operate at unsafe speeds. To avoid serious injury or death, do not modify the engine in any way. Never tamper with factory setting of the engine governor.

Emissions

Engines that are certified to comply with California and federal EPA emissions regulations for SORE (Small Off Road Equipment) are certified to operate on regular unleaded gasoline, and may include the following emissions control systems: Engine Modification (EM), Oxidizing Catalyst (OC), Secondary Air Injection (SAI) and Three Way Catalyst (TWC) if so equipped.

Spark Arrester

⚠ WARNING

This machine is equipped with an internal combustion engine and should not be used on or near any unimproved forest-covered, brush covered or grass-covered land unless the engine's exhaust system is equipped with a spark arrester meeting applicable local or state laws (if any).

When a spark arrester is used it should be maintained in effective working order. The State of California requires this by law (Section 4442 of the California Public Resource Code). Other states may have similar laws. Federal laws apply on federal lands.

Technical Data

MODEL SJ905

- Max. width - 24"/600 mm
- Max. intake height - 21"/533.4 mm
- Engine displacement - 179cc
- Torque - 9.0 Nm
- Fuel capacity - 2.5 L (0.66 US gal.) unleaded gasoline
- Oil reservoir capacity - 0.5 L/0.53 Quart

MODEL SJ906

- Max. width - 26"/66cm
- Max. intake height - 21"/530 mm
- Engine displacement - 208cc
- Torque - 11 Nm
- Fuel capacity - 2.7 L (0.71 US gal.) unleaded gasoline
- Oil reservoir capacity - 0.6 L/0.63 Quart

MODEL SJ907

- Max. width - 28"/710 mm
- Max. intake height - 21"/533.4 mm
- Engine displacement - 277cc
- Torque - 15.8 Nm
- Fuel capacity - 6 L (1.59 US gal.) unleaded gasoline
- Oil reservoir capacity - 1.1 L/1.16 Quart

MODEL SJ908









- Max. width - 30"/760 mm
- Max. intake height - 21"/533.4 mm
- Engine displacement - 277cc
- Torque - 15.8 Nm
- Fuel capacity - 6 L (1.59 US gal.) unleaded gasoline
- Oil reservoir capacity - 1.1 L/1.16 Quart

MODEL SJ909

- Max. width - 33"/830 mm
- Max. intake height - 21"/533.4 mm
- Engine displacement - 346cc
- Torque - 20.1 Nm
- Fuel capacity - 6.5 L (1.72 US gal.) unleaded gasoline
- Oil reservoir capacity - 1.1 L/1.16 Quart

Safety Symbols

The following table depicts and describes safety symbols that may appear on this product. Read, understand, and follow all instructions on the machine before attempting to assemble and operate.

Symbol	Description
	<p>READ THE OPERATOR'S MANUAL(S) Read, understand and follow all instructions in the manual(s) before attempting to assemble and operate.</p>
	<p>WARNING! ROTATING BLADES! Keep hands out of inlet and discharge openings when running. There are rotating blades inside.</p>
	<p>WARNING! ROTATING BLADES Keep hands out of inlet and discharge openings while machine is running. There are rotating blades inside.</p>
	<p>WARNING! ROTATING AUGER Do not put hands or feet near rotating parts, in the auger/impeller housing or chute assembly. Contact with the rotating parts can amputate hands and feet.</p>
	<p>WARNING! THROWN OBJECTS This machine may pick up and throw objects which can cause serious personal injury.</p>
	<p>WARNING! GASOLINE IS FLAMMABLE Allow the engine to be cooled at least two minutes before refueling.</p>
	<p>WARNING! CARBON MONOXIDE Never run an engine indoors or in a poorly ventilated area. Engine exhaust contains carbon monoxide, an odorless and deadly gas.</p>
	<p>WARNING! ELECTRICAL SHOCK Do not use the engine's electric starter in the rain.</p>

Assembly

Note: “Operator’s Position” is defined as standing directly behind the snow thrower.

Unpacking

- Remove snow thrower from the carton.
- Set carton debris aside or discard to prevent tire punctures and personal injury.
- Remove all loose parts from the unit
 - (1) Snow thrower
 - (2) Ignition/Safety keys (secured to unit)
 - (1) Operator’s manual
 - (1) Oil funnel for adding engine oil
 - (1) 5/8 Inch spark plug wrench
 - (1) Electric cord
 - (1) Oil can (empty)
 - (1) 10mm wrench
 - (1) Clean-out tool
 - (2) Shear pins with Bow-tie cotter pins

Upper and Lower Handle

⚠ WARNING

Unintentional engine start-up may result in serious injury. Always disconnect and ground the spark plug when conducting assembly or maintenance.

1. Remove plastic bubble wrap and cable ties from Auger and Drive Controls. (This will free up cable tension)
2. Remove the wing knobs, washers and bolts from the lower handle. (see Fig. 1-1)
3. Align the upper handle onto the lower handle.
4. Secure the upper handle and lower handle with the four wing knobs, cupped washers and carriage bolts previously removed and tighten.
5. There is a two wire lead coming from the engine, and another lead under the controls for the headlight. Connect these as shown in Fig 1-2.

Note: This already may be connected from the factory.

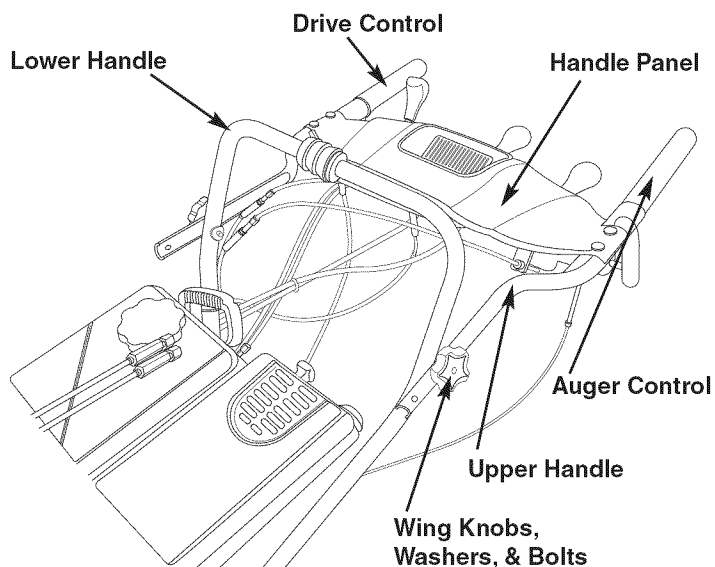

Figure 1-1

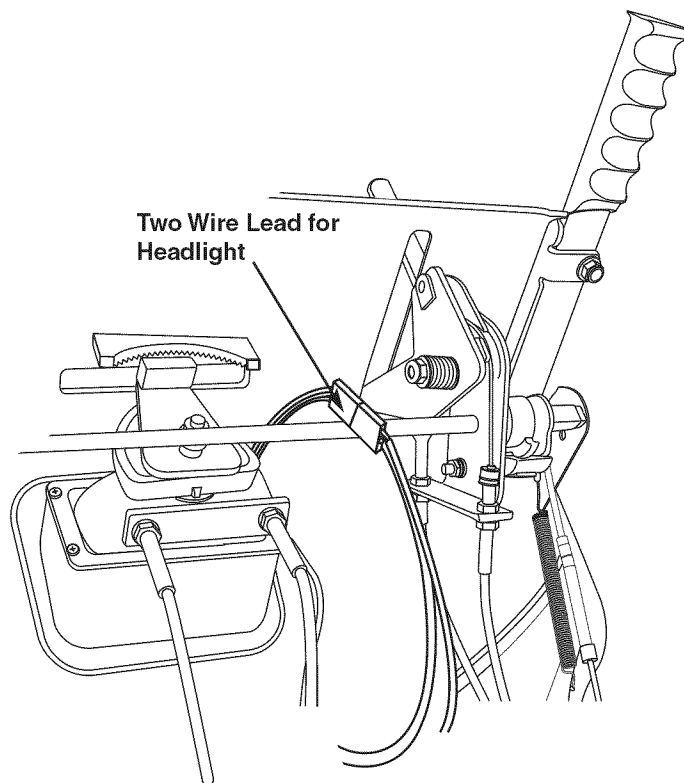

Figure 1-2

Auger and Drive Control Assembly

1. The Auger Control and Drive Control cables should already be connected from the factory. Adjustment to the control cables may be necessary. (See ‘Adjust Control Cables’ page. 11 for more details)
2. Test the auger for proper functionality as directed further in this manual. (See ‘Auger Control Test’ page. 11)

Important! Refer to Auger Control Test, Drive Control and Shift Lever prior to operating your snow thrower. Read and follow all instructions carefully and perform all adjustments to verify your snow thrower is operating safely and properly.

Chute Assembly

The chute assembly consists of the discharge and upper chute. The Discharge Chute controls the direction the snow is thrown. The Upper Chute controls the angle at which the snow is thrown. To move, use the Chute Directional Control.

1. Loosen and remove the bolt and washer from the chute chassis. (see Fig. 3)
2. Slide the discharge chute into the chute chassis. (see Fig. 2)

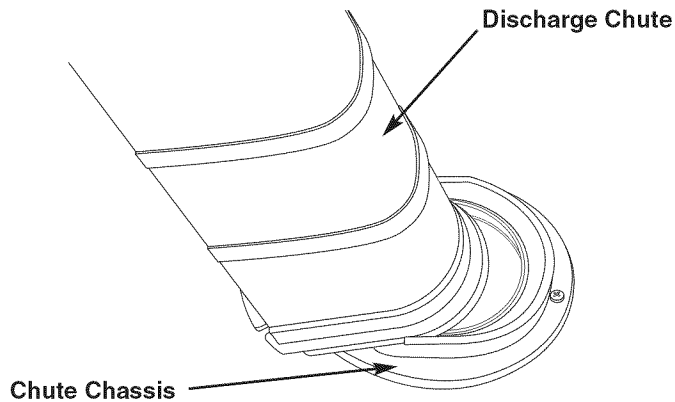

Figure 2

3. Align the hole of the discharge chute with the hole on the chassis chute.
4. Fasten the bolt and washer. (see Fig. 3)
Note: Use a 10mm wrench (included)

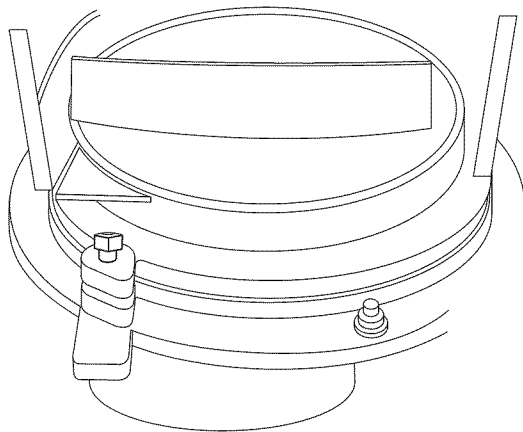

Figure 3

Chute Directional Control Assembly

The Chute Directional Control assembly consists of the Upper Shift and Lower Shift Bracket.

1. Remove the two (2) nuts and bolts from each side of the Lower Shift Bracket.
Note: Use a 13mm wrench (Not included)
2. Insert the Upper Shift Bracket assembly on the Lower Shift Bracket until it is locked in place.
3. Secure the Upper and Lower Shift Bracket with the two (2) nuts and bolts.
4. Tighten the nuts. (see Fig. 4)

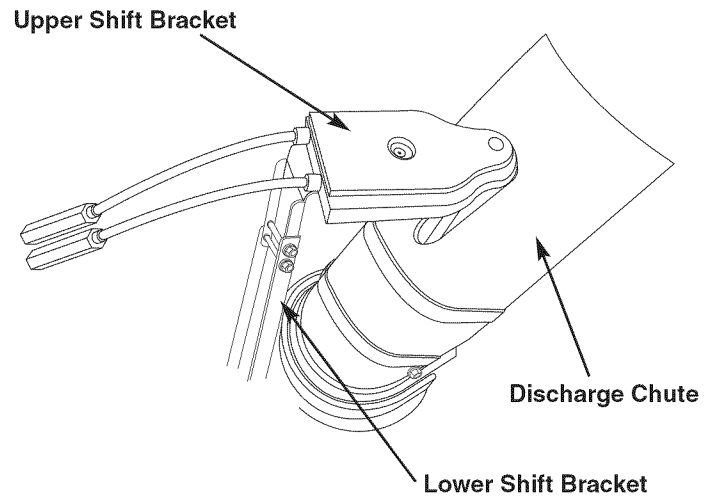

Figure 4

Fuel Recommendation

Use automotive gasoline (unleaded or low leaded to minimize combustion chamber deposits) with a minimum of 87 octane. Gasoline with up to 10% ethanol or 15% MTBE (Methyl Tertiary Butyl Ether) can be used. Do not use an oil/gasoline mixture, dirty or E85 gasoline. Avoid getting dirt, dust, or water in the fuel tank.

- Refuel in a well-ventilated area with the engine stopped. **Do not** smoke or allow flames or sparks in the area where the engine refueled or where gasoline is stored.
- **Do not** overfill the fuel tank. After refueling, make sure the tank cap is closed properly and securely.
- Be careful not to spill fuel when refueling. Spilled fuel or fuel vapor may ignite. If any fuel is spilled, make sure the area is dry before starting the engine.
- Avoid gasoline contact with skin or breathing of vapor.

Adding Fuel

⚠ WARNING

Gasoline is extremely flammable and the vapors are explosive which may result in serious injury or property damage. **Do not** fuel the snow thrower indoors or when the engine is hot. **Do not** use a pressurized starting fluid. Extinguish cigarettes, cigars, pipes and other sources of ignition. Use extreme care when handling gasoline, avoid spilling gasoline on yourself or your clothes. Wash your skin and change your clothes immediately if gasoline spills on them.

Note: A protective plastic cap may have been inserted in the fuel fill opening during manufacturing. Remove and dispose.

1. Clean around fuel filler neck before removing the fuel cap. (see Fig. 5)
2. A fuel level indicator small basket is located in the fuel tank. Fill the tank until the fuel reaches the fuel level indicator. Be careful not to overfill.

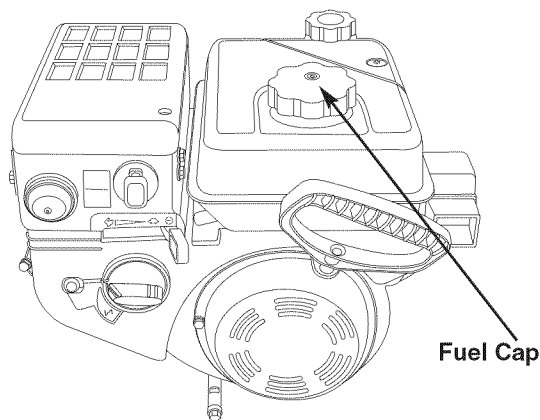

Figure 5

Adding Oil

⚠ CAUTION

The engine is shipped without oil in the engine. You must fill the engine with oil before operation. Running the engine with insufficient oil can cause serious engine damage and void the engine warranty.

1. Remove the oil filler cap and dipstick. Wipe the dipstick clean (see Fig. 6).
2. Slowly add oil until the oil level registers between high hole and low hole. Refer to the Engine Maintenance section for the correct oil viscosity and engine oil capacity.

Note: Use a 4 cycle, SAE 5W-30, or Equivalent Oil.

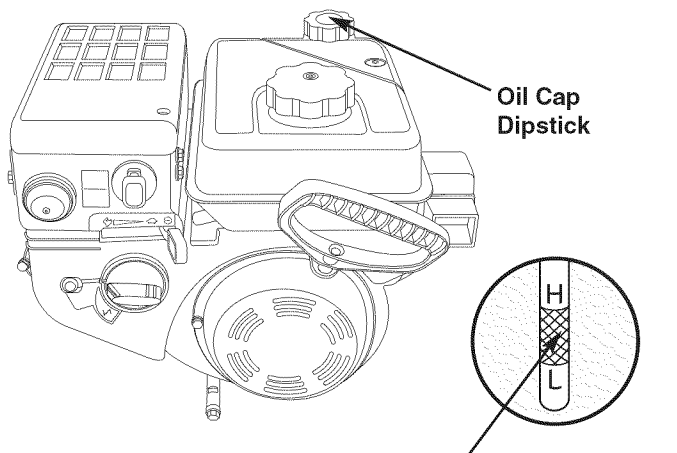

Fill between the high and low marks

Figure 6

Controls and Features

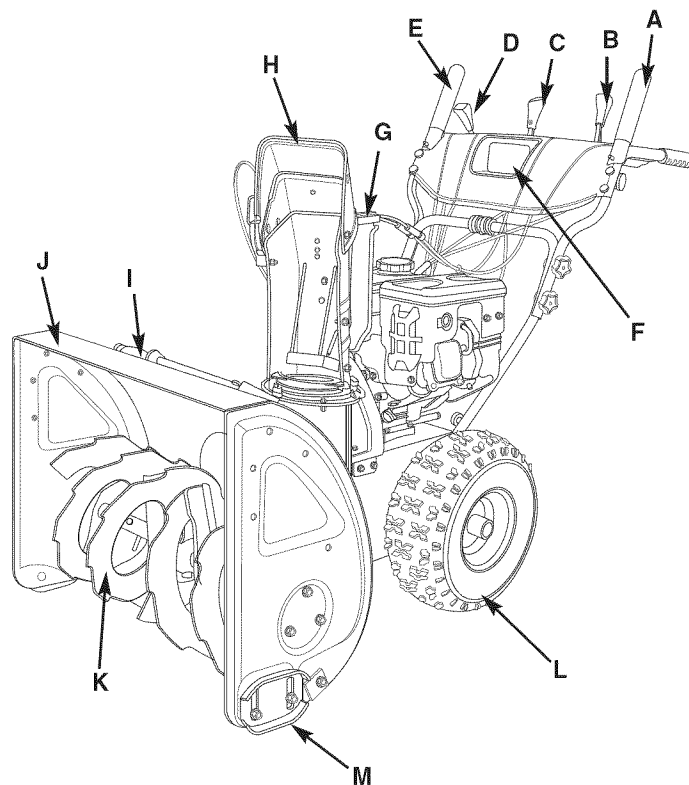

Figure 7

Parts List for Snow Thrower

- A. Auger Control
- B. Shift Lever
- C. Chute Direction Control
- D. Chute Tilt Control
- E. Drive Control
- F. Headlight
- G. Chute directional support
- H. Discharge chute
- I. Clean-out tool
- J. Main auger housing
- K. Auger
- L. Wheel
- M. Skid shoe

Auger Control: Used to engage and disengage the drive to the auger.

Important! Refer to Auger Control Test prior to operating your snow thrower. Read and follow all instructions carefully and perform all adjustments to verify your snow thrower is operating safely and properly.

Shift Lever: Used to regulate both the speed and direction of travel.

Chute Directional Control: Used to change the direction the snow is thrown.

Chute Tilt Control: Used to change the angle the snow is thrown.

Drive Control: Engages wheel drive.

Important! Always release the Drive Control before changing speeds.

Headlight: Provides light.

Skid Shoe: Used to adjust the space between the ground and the shave plate.

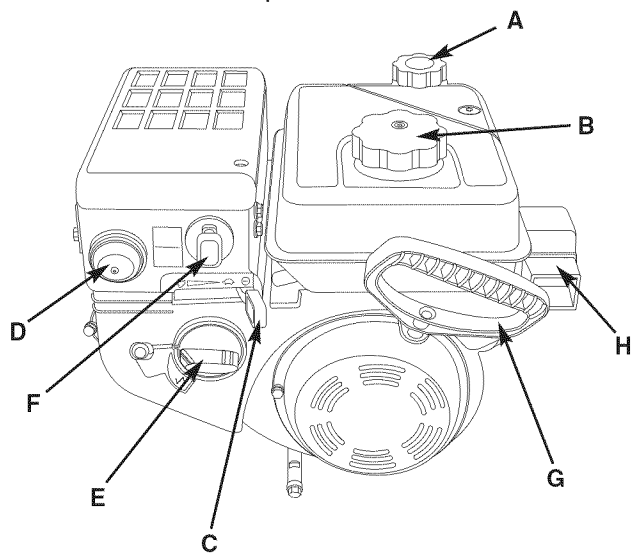

Figure 8

Parts List for Engine

- A. Oil Cap/Dipstick
- B. Fuel Tank Cap
- C. Throttle
- D. Primer
- E. Choke Control
- F. Safety Ignition Key
- G. Recoil Start Handle
- H. Electric Start Module

Oil Cap: Protects oils from dirt and debris. Remove to add oil.

Fuel Tank Cap: Protects fuel from dirt and debris. Remove to add fuel.

Safety Ignition Key: The ignition key must be fully inserted in order for the engine to start. The ignition key is a safety device and should be removed when the snow thrower is not in use.

Note: Do not turn the ignition key in an attempt to

start the engine. Doing so may cause it to break.

Primer: When pressed, forces fuel directly into engine's carburetor to aid in cold-weather starting.

Throttle Control: Regulates engine speed.

Recoil Start Handle: Used to manually start the engine.

Switch Box: The electric starter outlet requires the use of a three-prong outdoor extension cord and a 120V power source/wall outlet. Pressing the electric starter button engages the engine's electric starter.

Operation

⚠ WARNING

Review all safety warnings in this manual and labels on the machine before initiating operation. Failure to do so may result in serious injury or death. (see Safety section).

Important! Allow the engine to warm up for a few minutes after starting. The engine will not develop full power until it reaches operating temperature.

Starting the Engine

Before starting the engine do the following:

- Ensure the Auger and Drive controls are in the disengaged (up) position.
- Ensure the Throttle Control is in the FAST/RABBIT position.
- Insert the ignition key until it "snaps" into place. Do not turn the key.

If you are using the electric starter:

- Determine if your home wiring is a three-wire grounded system. If you are unsure have a licensed electrician check. Do not use the electric starter if your house does not have the proper wiring! See "Recoil Starter" for manual starting instructions. If your house is properly wired follow the steps in "Electric Starter".

Electric Starter

1. Ensure the wiring is a three-wire grounded system.
2. Insert the ignition key completely until it snaps into place. **Do not** turn the ignition key.
3. Connect the three-prong outdoor extension cord to Electric Starter Outlet on engine. Plug the other end of the cord into a three-hole, grounded 120 volt AC receptacle.
4. Move the Throttle Control to the FAST (rabbit) position.
5. Move Choke Control on the engine to the CHOKE position (cold engine start). If the engine is warm, move the lever to the RUN position.
6. Push Primer three (3) times, making sure to cover vent hole when pushing. If the engine is warm, push the primer only once. Always cover the vent hole when pushing. Cool weather may require priming to be repeated.

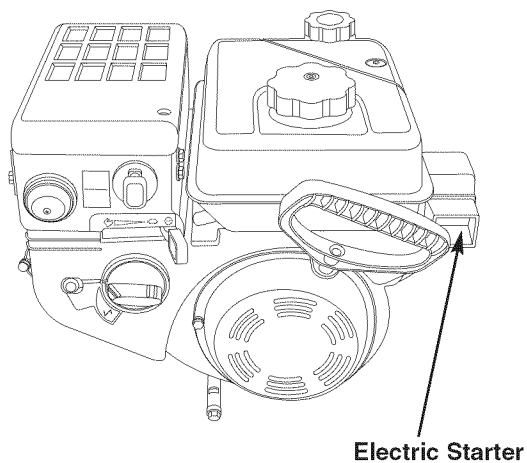

Figure 9

7. Push Electric Starter Button on the Electric Starter Outlet to start the engine. Immediately release the button once the engine starts. Continuing to press may damage the electric starter. The electric starter is equipped with thermal overload protection; the system will temporarily shut-down to allow starter to cool if electric starter becomes overloaded.
8. As engine warms, slowly move Choke Control to the RUN position. If the engine falters, restart the engine and run with the Choke Control at half-choke position for a short period of time, and then slowly rotate the choke into the RUN position.
9. After the engine is running, disconnect the power cord from the electric starter. When disconnecting the power cord, always unplug from the three – prong receptacle first and then from the snow thrower.

Recoil Starter

⚠ CAUTION

Pulling the Recoil Starter Handle while the engine is running may cause personal injury or damage to the machine. Do not pull the Recoil Starter Handle when the engine is running.

1. Insert the ignition key completely until it snaps into place. Do not turn the ignition key.
2. Move the Throttle Control to the FAST (rabbit) position.
3. Move Choke Control on the engine to the CHOKE position (cold engine start). If the engine is warm, move the lever to the RUN position.
4. Push Primer three (3) times, making sure to cover vent hole when pushing. If the engine is warm, push the primer only once. Always cover the vent hole when pushing. Cool weather may require priming to be repeated.
5. Pull gently on the starter handle until it begins to resist, then pull quickly and forcefully to overcome the compression. Do not release the handle and allow it to snap back. Return the rope SLOWLY to the original position. If required, repeat this step.
6. As engine warms, slowly move Choke Control to the RUN position. If the engine falters, restart the engine and run with the Choke Control at half-choke position for a short period of time, and then slowly rotate the choke into the RUN position.

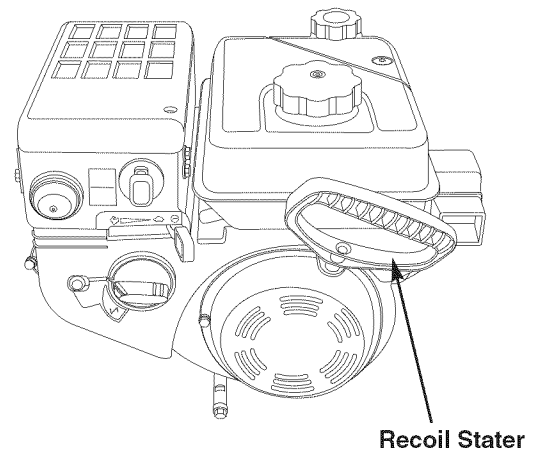

Figure 10

Engaging the Wheel Drive

1. With the engine running near top speed, move the shift lever into one of the six FORWARD positions or two REVERSE positions, Select a speed appropriate for the snow conditions that exist.
2. Squeeze the auger control and the augers will turn. Release it and the augers will stop.
3. Squeeze the drive control and the snow thrower will move. Release it and drive motion will stop. NEVER move shift lever without releasing drive control.

Engaging the Augers

To engage the augers and start throwing snow, squeeze the Auger Control against the handle. Release to stop the augers.

Auger Control Test

Important! Perform the following test before operating your snow thrower for the first time and the start of each winter season.

Check the adjustment of the auger control as follows:

- When the auger control is released and in the disengaged “up” position, the cable should have very little slack. It should NOT be tight.
- In a well-ventilated area, start the snow thrower engine as instructed earlier in this section.
- While standing in the operator’s position (behind the snow thrower), engage the auger.
- Allow the auger to remain engaged for approximately ten (10) seconds before releasing the auger control. Repeat this several times.
- With the engine running and the auger control in the disengaged “up” position, walk to the front of the machine and confirm that the auger has completely stopped rotating and shows NO sign of motion.

Adjusting the Control Cable

⚠ WARNING

A rotating auger may cause serious injury. If the auger shows ANY signs of rotating, immediately return to the operator's position and shut off the engine by removing the safety ignition key. Wait for ALL moving parts to stop before re-adjusting the auger control.

1. To readjust the control cable, loosen the hex jam nut on the auger control cable "Z" fitting.
2. Rotate the coupling end of the cable counterclockwise to provide more slack.
3. Retighten the hex jam nut. (see Fig. 11)
4. Repeat Auger Control Test to verify proper adjustment has been achieved. Repeat the previous steps to provide more slack in cable, if necessary.

Auger Assist

The drive and auger controls are capable of working together. When the right drive lever is engaged, the left auger lever can be engaged and will stay engaged. Releasing/disengaging the drive lever will also release/disengage the auger lever. This enables the operator to control throw angle and direction while the machine is in motion using after hand.

1. **DO NOT** force the auger lever up. Release the drive lever to also disengage the auger.
2. **DO NOT** change drive speeds or forward/reverse direction when the drive is engaged.

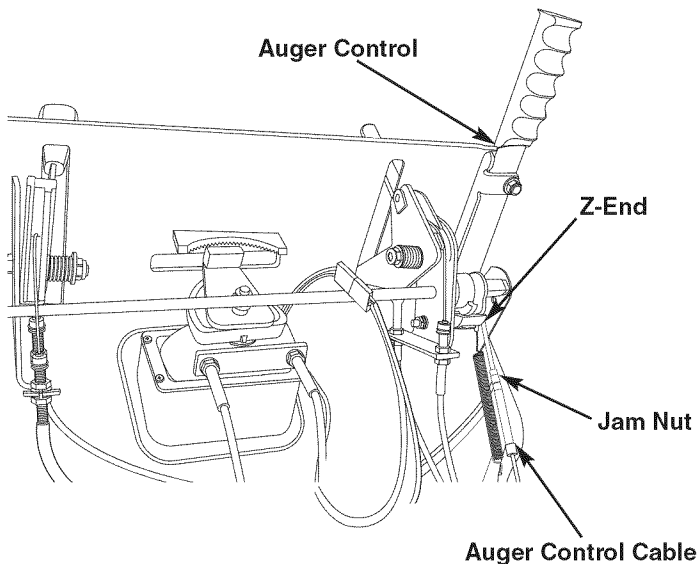

Figure 11

Clean-out

⚠ WARNING

A rotating auger may cause serious injury. If the auger shows ANY signs of rotating, immediately return to the operator's position and shut off the engine by removing the safety ignition key. Wait for ALL moving parts to stop before cleaning snow or ice from the chute assembly.

Use the clean-out tool (fastened to the top of the auger housing) to remove snow or ice that may lodge itself in the chute assembly. Proceed as follows to safely clean the chute assembly:

1. Release both the Auger Control and the Drive Control/ Auger control lock.
2. Stop engine by removing the safety ignition key.
3. Remove the clean-out tool from the mounting clip.
4. Use one end of the clean-out tool to dislodge and scoop any snow and ice that has formed in and near the chute assembly.
5. Refasten the clean-out tool to the mounting clip on the top of the auger housing, and restart the engine.
6. While standing in the operator's position (behind the snow thrower), engage the auger control for a few seconds to clear any remaining snow and ice from the chute assembly.

Operating Tips

⚠ WARNING

Contact with hot components (i.e.: muffler) on the machine may cause burns. Allow the machine to cool off before handling.

Follow these tips for more efficient snow throwing:

1. Run the engine for a few minutes before starting. The engine will not develop full power until it reaches operating temperatures.
2. Remove snow immediately after it falls.
3. Discharge the snow downwind whenever possible.
4. Slightly overlap each previous path.
5. Set the skid shoes 1/4" below the shave plate for normal usage. The skid shoes may be adjusted upward (to lower the shave plate) for hard-packed snow. Adjust downward (to raise the shave plate) when using on gravel or crushed rock.
6. Be certain to follow the precautions found in the Stopping the Engine section to prevent possible freeze-up.
7. Clean the snow thrower thoroughly after each use.
8. Run the engine for a few minutes before stopping to help dry off any moisture on the engine.

Stopping the Engine

Shut down procedures are the same if you use the electric start or the manual start.

1. Disengage both the drive and the auger controls.
2. Slow the engine throttle to the 'turtle' position.
3. Remove the safety ignition key from its location. Do not turn the key.
4. The engine will stop as soon as the key is removed.
5. Remove all snow and debris from the controls for the next use.

Adjustments and Maintenance

⚠ WARNING

Unexpected auger movement may cause personal injury. Before servicing, repairing or inspecting the snow thrower, disengage the Auger Control. Stop the engine and remove the Ignition Key to prevent unintended start up.

Adjustments

Auger Control

Refer to the Auger Control Test in the Operation section of this manual for Auger Control adjustment instructions.

Drive Control and Shift Lever

⚠ CAUTION

Fuel spillage may ignite if in contact with an ignition source and cause personal injury or property damage. Always drain the fuel into an approved container and place a plastic film under the Gas Cap before turning the machine over to make adjustments.

Follow these steps to adjust the Drive Control and Shift Lever:

1. With the engine off, move the shift lever all the way forward to the highest speed. With the drive control released, push the snow thrower forward. The unit should roll forward. Then engage the drive control. The wheels should stop turning.
2. Release the drive control and push the unit again. Tip the snow thrower back so that it rests on the handle.
3. Move the shift lever back to the fast reverse position then all the way forward again. There should be no resistance in the shift lever, and the wheels should keep turning.
4. If you have resistance when moving the shift lever or the wheels stop when they should not, loosen the jam nut on the drive control cable and unthread the cable one turn.

5. If the wheel does not stop when you engage the drive thread the cable in one turn.
6. Recheck the adjustment and repeat as necessary. Tighten the jam nut to secure the cable when correct adjustment is reached.

Follow these steps to check if you have the correct adjustment:

1. Tip the snow thrower forward, allowing it to rest on the auger housing. (see Fig. 12)

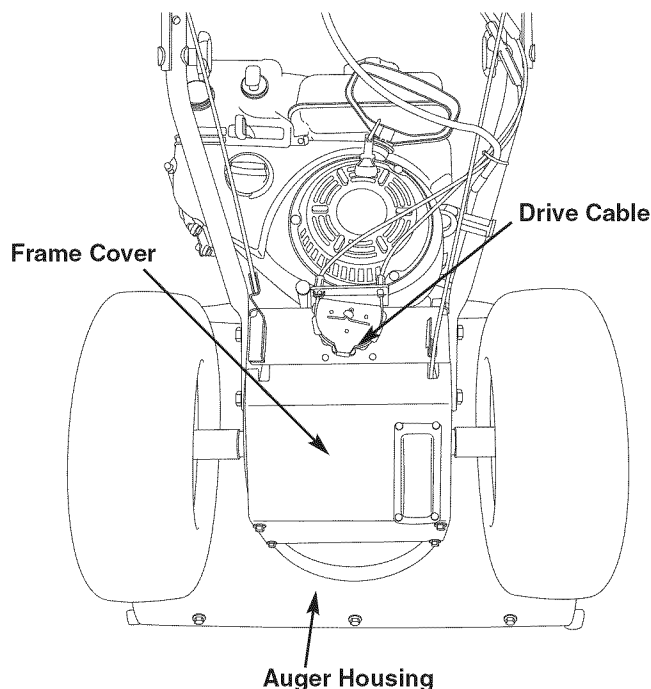

Figure 12

2. Remove the frame cover underneath the snow thrower by removing the six self-tapping screws.
3. With the drive control released, there must be clearance between the friction wheel and the drive plate in all positions of the shift lever.
4. With the drive control engaged, the friction wheel must contact the drive plate. (see Fig. 11)

If further adjustment is necessary:

1. Loosen the jam nut on the drive cable. Adjust the cable as necessary. (see Fig. 13)

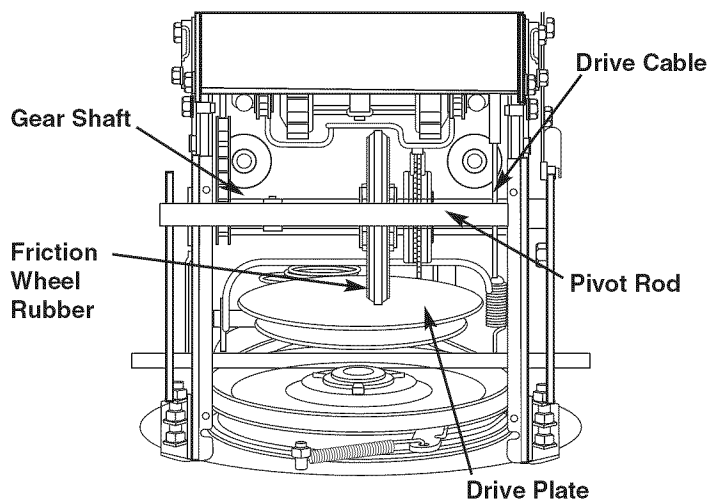

Figure 13

2. Retighten the jam nut to secure the cable when correct adjustment is reached.
3. Reassemble the frame cover. If you placed plastic film under the gas cap, be certain to remove it before operating the snow thrower.

Shift Cable

Follow these steps to adjust Shift Cable:

1. Put the shift lever between forward and reverse.
2. Open the frame cover to check the position of the Infinity Variable Speed Wheel.
3. Adjust the two nuts of Shift Cable until the Infinitely Variable Speed Wheel is positioned on the middle of friction gear.

Skid Shoes

⚠ WARNING

Projection of loose gravel may cause serious injury. Do not operate the snow thrower on gravel.

Adjust the Skid Shoes to step the gap between the Shave Plate and ground. Follow these steps to adjust the Skid Shoes:

Tips:

- For close snow removal on a smooth surface, raise skid shoes higher on the auger housing.
- Use a middle or lower position when the area to be cleared is uneven.

Adjustment:

1. Loosening the flange lock nuts and carriage bolts. Move skid shoes to desired position. (see Fig. 14)
2. Ensure the entire bottom surface of skid shoe is against the ground to avoid uneven wear on the skid shoes. Retighten nuts and bolts securely.

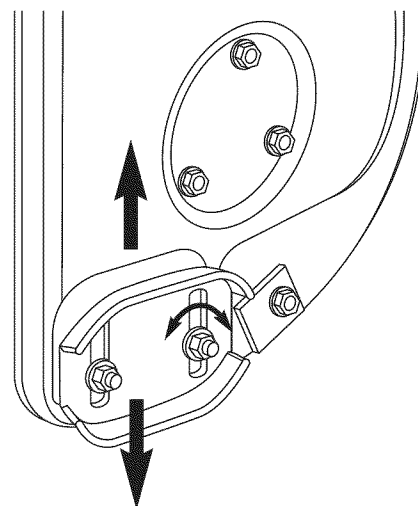

Figure 14

Carburetor

Minor carburetor adjustment may be required to compensate for differences in fuel, temperature, altitude and load. Refer to the separate manual, packed with your unit, for carburetor adjustment information.

Maintenance

Lubrication

Lubricate the snow thrower as follows:

Gear Shaft: Lubricate the Gear Shaft with 6-n-1 grease at least once a season or after every 25 hours of operation (available at automotive stores).

Important! Keep all grease and oil off of the rubber friction wheel and aluminum drive plate.

Gear Case: The gear case is lubricated with grease at the factory and it does not require checking. If disassembled for any reason, lubricated with 2 ounces (60ml) of shell Alvania grease EPR00. Before reassembling, remove old sealant and apply new sealant.

Important! Do not overfill the gear case, since damage to the seals could result. Be sure the vent plug is free of grease in order to relieve pressure.

Drive and Shifting Mechanism: Lubricate at least once a season or after 25 hours of operation. Remove the rear cover and lubricate any chains, sprockets, gears, bearings, shafts, and shifting mechanism at least once a season. Use engine oil or a spray lubricant. **Avoid getting oil on the friction wheel rubber and aluminum drive plate.** (see Fig. 13)

Auger Bearings: Every season lubricate the auger bearings and the bearings on the side of the frame with light oil. (see Fig. 15)

Auger Shaft: At a minimum, once a season remove the shear pins on the auger shaft. Spray lubricant inside the shaft and lubricate the plastic auger bearings. (see Fig.15)

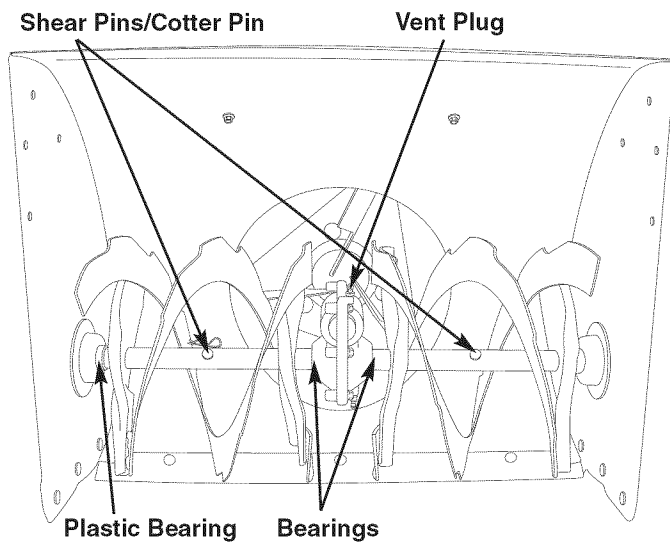

Figure 15

Engine

⚠ WARNING

Unexpected start up may cause personal injury. Before servicing, repairing or inspecting the snow thrower, disengage all controls, disconnect and ground the spark plug wire. Stop the engine and remove the Ignition Key to prevent unintended start up.

Periodic inspection and adjustment of the engine is necessary to maintain high performance. Regular maintenance will also ensure a longer service life.

Auger

- The augers are secured to the spiral shaft with two shear pins and cotter pins. If you hit a hard foreign object or ice jam, the snow thrower is designed so that the pins may shear off and the auger will not turn. This is normal. (see Fig. 15)
- If the augers will not turn, check to see if the pins have sheared. Replacement shear pins and cotter pins are see page 18 for parts. When replacing bolts, available, spray an oil lubricant into shaft before inserting new pins.

Important! NEVER replace the auger shear pins with standard pins. Any damage to the auger gearbox or other components as a result of doing so will not be covered by your snow thrower's warranty.

Storage

Off-Season Storage

⚠ WARNING

Never store the machine or fuel container indoors where there is an open flame, spark, or pilot light such as on water heater, furnace, clothes dryer, or other Gas appliance.

⚠ WARNING

Fuel spillage may ignite if in contact with an ignition source and cause personal injury or property damaged. Always allow the engine to cool and all sources of ignition are extinguished. Drain the fuel into an approved container. Fuel left in the engine for extended periods of time deteriorates and will cause starting problems.

Engines stored over 30 days need to be drained of fuel to prevent deterioration and gum from forming in the fuel system or on essential carburetor parts. If the gasoline in your engine deteriorates during storage, you may need to have the carburetor, and other fuel system components, serviced or replaced.

If the snow thrower will not be used for 30 days or longer, follow these instructions:

1. Remove all fuel from the tank by running the engine until it stops.
2. Change the engine oil.
3. Remove gasoline from carburetor and fuel tank to prevent gum deposits from forming on these parts and causing possible malfunction of engine.
4. Drain carburetor by pressing upward on bowl drain, located below the carburetor cover. Note: Fuel stabilizer is an acceptable alternative in minimizing the formation of fuel gum deposits during storage. Do not drain carburetor if using fuel stabilizer.
5. Remove the spark plug and pour approximately 1 oz. (30ml) of clean engine oil into the cylinder. Pull the Recoil Starter several times to distribute the oil, and reinstall the spark plug.
6. Clean debris from around the engine and behind the muffler. Apply a light film of oil on any areas that are susceptible to rust.
7. Store in a clean, dry, well ventilated area away from any appliance that operates with a flame or pilot light, such as a furnace, water heater or clothes dryer. Avoid any area with a spark producing electric motor, or where power tools are operated.
8. If possible, avoid storage areas with high humidity.
9. Keep the engine level in storage. Tilting the engine can cause fuel or oil leakage.

Note: When storing any type of power equipment in an unventilated or metal storage shed, care should be taken to rust proof the equipment. Using a light oil or silicone, coat the equipment, especially any chains, springs, bearings and cables.





Troubleshooting

Problem	Cause	Remedy
Engine fails to start	<ol style="list-style-type: none"> 1. Fuel tank empty, or stale fuel. 2. Blocked fuel line 3. Key not inserted all the way 4. Spark plug wire disconnected. 5. Faulty spark plug 6. Primer button not being used properly. 	<ol style="list-style-type: none"> 1. Fill tank with clean, fresh gasoline. Fuel becomes stale after thirty days. 2. Clean the fuel line. 3. Insert key all the way 4. Connect spark plug wire 5. Clean spark plug, readjust gap or replace.
Engine runs erratic	<ol style="list-style-type: none"> 1. Unit running on CHOKE 2. Blocked fuel line or stale fuel 3. Water or dirt in the fuel system 	<ol style="list-style-type: none"> 1. Move the Choke Control to RUN. 2. Clean the fuel line; fill the tank with clean fresh gasoline. 3. Drain the fuel tank and carburetor. Refill with fresh fuel.
Loss of power	<ol style="list-style-type: none"> 1. Spark plug wire loose 2. Gas cap vent hole plugged 	<ol style="list-style-type: none"> 1. Connect and tighten spark plug wire. 2. Remove ice and snow from gas cap. Be certain vent hole is clear.
Excessive vibration	<ol style="list-style-type: none"> 1. Loose parts or damaged auger. 	<ol style="list-style-type: none"> 1. Stop the engine immediately and disconnect the spark plug wire. Tighten all bolts and nuts. If vibration continues, have the unit serviced by an authorized service dealer.

Troubleshooting

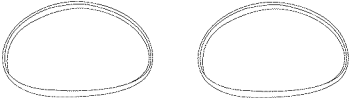
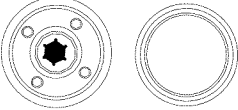
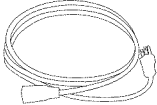
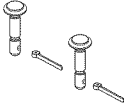
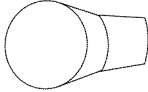
Problem	Cause	Remedy
Unit fails to propel itself	<ol style="list-style-type: none"> 1. Auger control cable out of adjustment. 2. Drive belt loose or damaged. 	<ol style="list-style-type: none"> 1. Adjust drive control cable. Refer to Adjustments and Maintenance Section. 2. Replace drive belt. Refer to the Adjustments and Maintenance
Unit fails to discharge snow	<ol style="list-style-type: none"> 1. Chute assembly clogged 2. Shear pins sheared 3. Foreign object lodged in auger. 4. Auger control cable in need of adjustment. 5. Auger belt loose or damaged. 	<ol style="list-style-type: none"> 1. Stop engine and disconnect spark plug wire. Clean chute and inside of auger housing with clean-out tool or a stick. 2. Replace shear pins. 3. Stop engine immediately and disconnect spark plug wire. Remove object from auger. 4. Adjust auger control cable. Refer to Adjustments and Maintenance Section. 5. Refer to Maintenance Section.

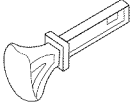
Replacement Parts

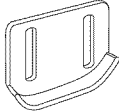
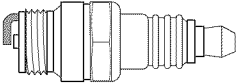
Component	Part Number and Description
	SJ900-001 Auger Drive Belt SJ900-002 Wheel Drive Belt
	SJ900-003 Friction Wheel Assembly SJ900-004 Friction Wheel Rubber
	SJ900-005 Extension Cord
	SJ900-006 Shear Pin, 1.50 SJ900-007 Bow-tie Cotter Pin
	SJ900-008 Lamp, 12V
	SJ900-009 Chute Clean-out Tool
	SJ900-010 Key
	SJ900-011 Shave Plate, 24" SJ900-012 Shave Plate, 26" SJ900-013 Shave Plate, 28" SJ900-014 Shave Plate, 30" SJ900-015 Shave Plate, 33"
	SJ900-016 Slide Shoe, Standard
	SJ900-017 Spark Plug

Please call our customer service team for assistance at **866-766-9563 (866-SNOW-JOE)**
 Or visit **www.snowjoe.com** and click on **'Customer Service'**.

Our service representatives and technicians will be happy to assist you with any questions you may have. Our office hours are 9am to 5:30 pm Eastern Time.
 Thank you for choosing our products!

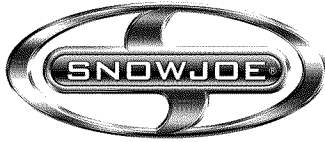

A Two-Year Full Warranty for residential use in the United States and Canada

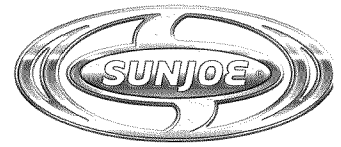

General Conditions:

Snow Joe, LLC warrants this product to the original purchaser for two years against defects in material or workmanship when used for normal residential purposes. Snow Joe, LLC will repair any defect in material or workmanship, and repair or replace any defective part, subject to the conditions, limitations, and exclusions set forth herein. Such repair or parts replacement will be free of charge to the original purchaser except noted below.

The duration of the warranty applies only if the product is put to personal use around the household or residence. If the product is put to any business use, commercial or industrial, then the duration of this warranty is 90 days from the date of original purchase. If any product is rented or leased, the duration of the warranty is 90 days from the date of original purchase.

It is the owner's responsibility to perform correctly all maintenance and minor adjustments explained in the owner's manual.

Electric Products:

In order to obtain a replacement electric powered unit or repair the existing electric powered unit, you must return the complete unit, postage prepaid, to the **Snow Joe Center, 86 Executive Avenue, Edison, NJ 08817**

Gasoline / Battery Products:

Limitations

- Batteries are warranted only for the period of 12 months after the date of purchase on a prorated basis. Rechargeable batteries will be replaced free of charge during the first 90 days. After the initial 90 days, batteries will be replaced at prorated cost to the customer
- Idlers, cables, and electrical components are warranted to the original purchaser for use at household or residence for a period of two years

Exclusions

- Snow Joe Brand Engines are covered under this warranty. All other engines and engine accessories are covered only by the engine manufacturer's warranty and are not covered by this warranty
- Parts used that are not genuine Snow Joe parts are not covered by this warranty
- Damages resulting from misuse, alteration, improper assembly, improper adjustment, neglect, or accident which requires repair is not covered under this warranty

Snow Joe, LLC may from time to time change the design of its products. Nothing contained in this warranty shall be construed as obligating Snow Joe, LLC to incorporate such design changes into previously manufactured products, nor shall such changes be construed as an admission that previous designs were defective.

This warranty is intended to cover product defects only. Snow Joe, LLC is not liable for indirect, incidental or consequential damages in connection with the use of the Snow Joe Products covered by this warranty. This warranty does not cover any cost or expense incurred by the purchaser in providing substitute equipment or service during reasonable periods of malfunction or non-use of this product, while waiting for completion of repairs under this warranty. Some states do not allow exclusions of incidental or consequential damages, so the above exclusions may not apply in all states. This warranty gives you specific legal rights in your state, which vary from state to state.

If you wish to contact Snow Joe, please direct inquiries to the:

**Customer Service Department
Snow Joe Center
86 Executive Avenue
Edison, NJ 08817**

Customers who have purchased Snow Joe products exported from the United States and Canada should contact their Snow Joe Distributor (Dealer) to obtain information applicable for your country, province, or state. If for any reason, you are not satisfied with the distributor's service, or if you have difficulty obtaining warranty information, contact your Snow Joe importer. If in the event your efforts are unsatisfactory, please write to the Snow Joe Center at the above address.

If you have any questions about your product warranty, please call 1-866-SNOW-JOE or visit us online at www.snowjoe.com.