

OWNER'S GUIDE

F52F
**ELECTRONIC
AIR CLEANER**

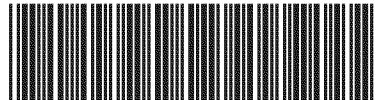
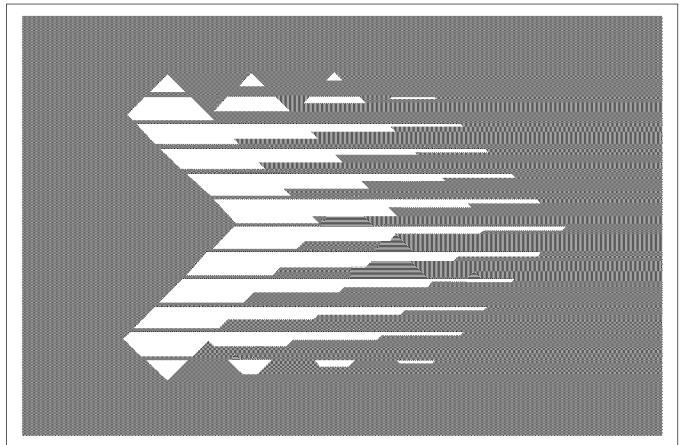

CONTENTS

	PAGE
THE SOLID STATE PERFORMANCE INDICATOR	2
OPERATING YOUR ELECTRONIC AIR CLEANER	3
GETTING THE MOST FROM YOUR AIR CLEANER	5
CLEANING THE CELL(S) AND PREFILTER	6
HOW ELECTRONIC AIR CLEANING WORKS	15
BEFORE YOU CALL FOR SERVICE	20
HONEYWELL 10 YEAR CLEAN COIL GUARANTEE	22
PERFECT CLIMATE®	24
LIMITED TWO-YEAR WARRANTY	25

THE SOLID STATE PERFORMANCE INDICATOR

This air cleaner is equipped with a special solid state circuit that operates the optional W8600E Solid State Performance Indicator (see photo).

The W8600E Indicator is designed to be mounted next to your thermostat, and to monitor the air cleaner performance.

If you have ordered the W8600E Indicator, you will notice three light-emitting diodes (LEDs) on the W8600E labeled ON, WASH and CHECK.

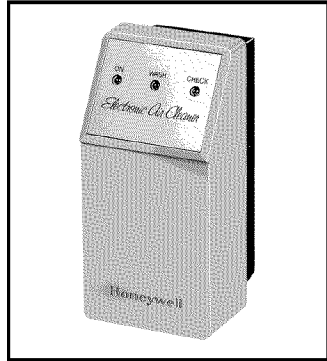

- During normal air cleaner operation, the ON LED is lit (whenever the system fan is on).
- If excessive dirt has accumulated on the air cleaner's cell(s), the WASH LED will light to alert you that a cell and prefilter wash is past due.
- Extreme dirt loading (beyond that required to activate the WASH LED), electronic malfunction, or other equipment problems will cause the CHECK LED to light.

OPERATING YOUR ELECTRONIC AIR CLEANER

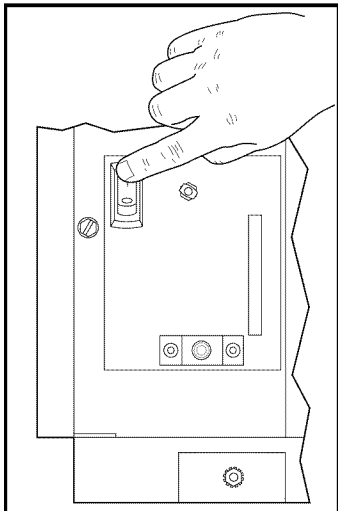

ONE-CELL MODEL SHOWN.

Set the ON-OFF switch to ON. The air cleaner will now operate whenever your furnace/air conditioning system fan operates. For maximum air cleaning benefit and cleaner air conditioner coils, leave the air cleaner switch on at all times and the fan switch on your thermostat on. Of course, continuous fan operation will add a small amount to your electric bill each month.

When the fan comes on, the neon light located near the ON-OFF switch will light, indicating that the air cleaner is functioning.

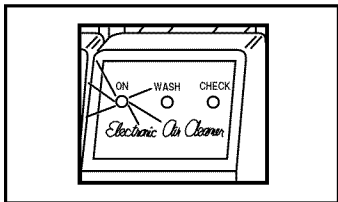

If your air cleaner is equipped with a wall-mounted W8600E Solid State Performance Indicator (see page 2), the ON LED will be on *whenever the air cleaner is in operation*. Of course, the system fan will also be running.

You may hear a snapping electrical arcing sound occasionally as the air cleaner operates. This is usually caused by a larger dust particle causing a high voltage discharge. The snapping sound means that your air cleaner is working as it should.

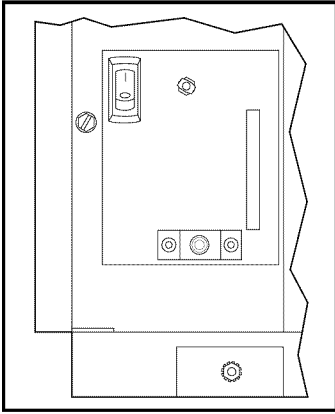

ONE-CELL MODEL SHOWN.

When the fan stops, the neon light goes out, as does the ON LED on the Solid State Performance Indicator. The air cleaner is off until the heating or air conditioning and fan start again.

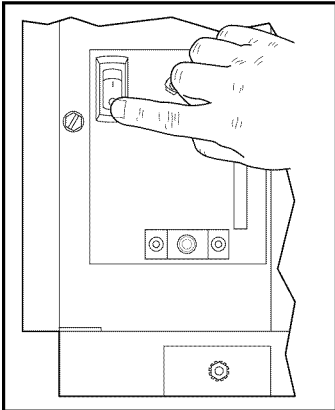
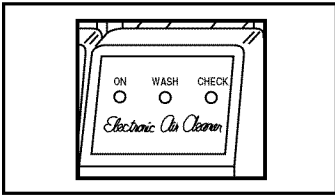

ONE-CELL MODEL SHOWN.

If you do not want the air cleaner to run, set the ON-OFF switch to OFF to turn off the air cleaner. Your furnace and air conditioner will still operate normally, but without the added benefit of air cleaning. Normally, this switch should be ON at all times.

GETTING THE MOST FROM YOUR AIR CLEANER

Run the air cleaner as much as possible

For greatest efficiency, the air cleaner should run all the time. To do this, set the fan switch on your thermostat to ON, and make sure the air cleaner is switched on. The fan and air cleaner will run even when the furnace or air conditioner is off. Note: A manual fan switch may be built into the furnace fan controller.

The air cleaner itself uses less power than a 40 watt light bulb (two-cell model—33 watts; single-cell model—22 watts). You will also have the cost of running the system fan to consider. Generally the added cost is more than offset by the added benefits of full time air cleaning and improved air circulation. Some people feel that room temperatures stay more even when the fan is always on.

Even if your thermostat does not have a fan ON position, you can obtain maximum available air cleaning benefit by making sure the air cleaner is always switched on so it operates whenever the furnace or air conditioner is on.

Keep the cell(s) and prefilter clean

Although the air cleaner is designed to be efficient over a wide range of cell loading conditions, regular cleaning is your best assurance of consistent performance. Also, a very dirty cell and prefilter reduces air flow and, in turn, this reduces the efficiency of the furnace or air conditioner.

CLEANING THE CELL(S) AND PREFILTER

Setting a regular cleaning schedule

To ensure optimum performance from the air cleaner, the cell(s) and prefilter must be cleaned regularly—every one to six months. Washing frequency will vary depending on the number of family members, pets, activities (such as cooking, woodworking, etc.) and smoking habits. Use the wash reminder schedule included in the literature package to help establish and maintain a regular cleaning schedule.

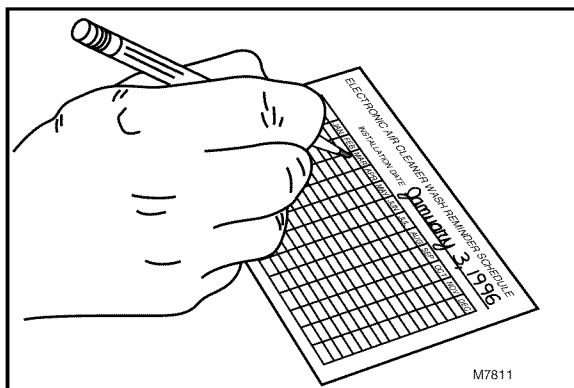

If your air cleaner has a W8600E Indicator (shown on page 2), the WASH LED will light to remind you that a cell and prefilter washing is past due. When the WASH LED comes on, it means that the cell(s) are loaded with dirt to the point that air cleaning efficiency is diminished. You should plan to wash the cell(s) and prefilter as soon as possible. By using the wash reminder schedule, a washing schedule can be established that keeps the cell(s) clean enough so the WASH LED does not come on.

If you find that the WASH LED is coming on more frequently than the schedule that was established on the wash reminder schedule, you may have a buildup of residue on the ionizer wires. If the collector plates on the cell(s) look clean, you can try wiping the ionizer wires with a clean cloth instead of washing the entire cell.

You can also consider whether some activity in your home has changed, causing the cell(s) to become dirty faster. Have the windows been open more often? Has someone been smoking more often? Has someone taken up woodworking?

NOTE: You can let the heating or air conditioning system operate normally while the cell(s) is being washed. Simply turn off the air cleaner switch.

**Removing the
electronic cell(s)
and prefilter**

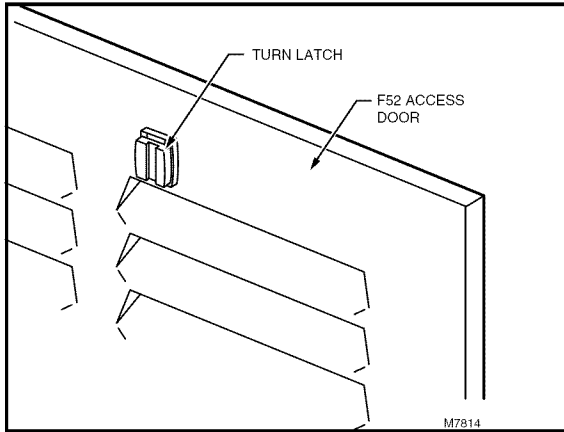

STEP 1

Open the door by turning the two door latches.

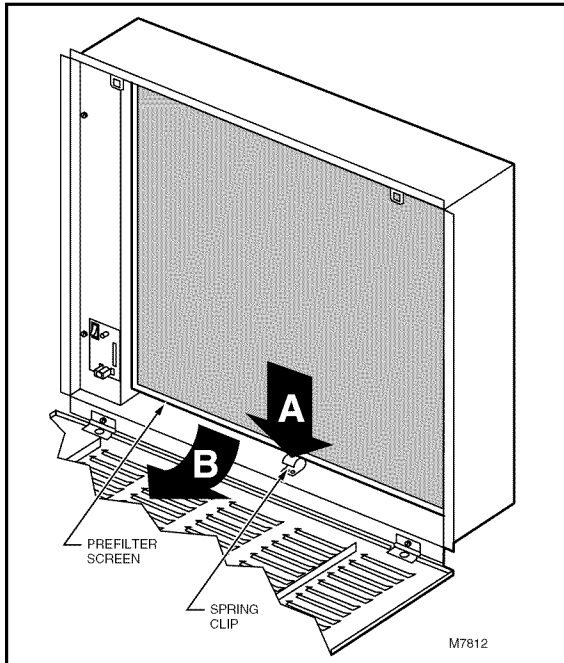

STEP 2

The prefilter is held in place by a spring clip and a U-shaped channel. Lift the prefilter at the spring clip end and slide it out of the U-shaped channel.

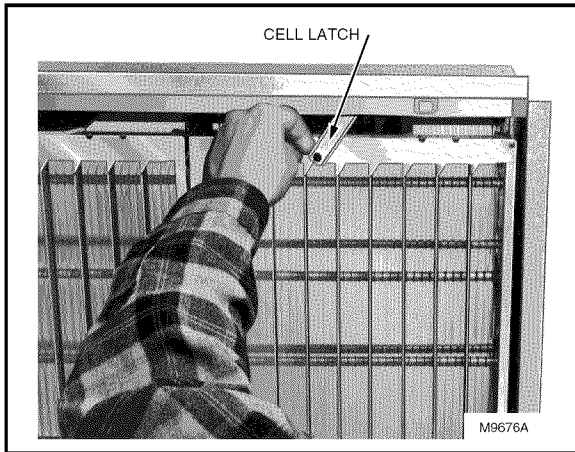

STEP 3

The electronic cell(s) are held in the air cleaner by a latch at the top, and metal hooks on the bottom. Push the cell inward to release the latch and rotate the latch away from the cell. See photo.

STEP 4

Lift the cell and tip it slightly to release it from the cell hooks.

Cleaning the prefilter

The prefilter can be vacuumed, brushed, sprayed with a garden hose, or washed at the same time as the electronic cell(s).

CAUTION

Burn hazard.

Can cause personal injury.

Allow the cell(s) to cool completely in the dishwasher at the end of the wash cycle or wear protective gloves to avoid burns. Hot water can accumulate in the tubes supporting the collector plates. Tip the cell(s) so these tubes drain.

IMPORTANT

- *Check your dishwasher owner's manual. Some manufacturers do not recommend washing electronic cell(s) in their dishwashers.*
- *If the dishwasher has upper and lower arms, position the cell(s) carefully to allow good water circulation.*
- *Use care to avoid damaging the cell(s) when placing them in the dishwasher. Broken ionizer wires or bent collector plates are not covered under the warranty.*
- *Very dirty cell(s), especially from tobacco or cooking smoke, can discolor the plastic parts and the lining of some dishwashers. This discoloration is not harmful. To minimize it, wash the cell(s) more frequently or try a different brand of detergent.*
- ***Do not allow the dishwasher to run through the dry cycle. This bakes on any contaminants not removed during the wash cycle and reduces air cleaner efficiency.***

STEP 1

Put the cell(s) on the lower rack of the dishwasher with the airflow arrow pointing up. It may be necessary to remove the upper rack. Do not block water flow to the upper arm, if provided on your dishwasher. Hint: Lay a few large water tumblers between the spikes on the lower rack and rest the cell(s) on them so the spikes do not damage the aluminum collector blades.

STEP 2

Using the detergent that works best for normal dishwashing, allow the dishwasher to run through the complete wash and rinse cycle. **Do not use the dry cycle.** To avoid burns, let the cell(s) cool completely before removing, or wear protective gloves when removing the cell(s). Remember that water can be trapped inside the cell(s) tubes. Tip the cell(s) to drain.

STEP 3

Wipe the ionizer wires and contact board on the end of the cell with a clean cloth.

STEP 4

Inspect the dishwasher. You may wish to rerun the wash and/or rinse cycle with the dishwasher empty if you see dirt or residue from washing the cell(s). If dirt or residue seems excessive, wash the cell(s) more often or try a different detergent.

**Washing the
cell(s) in a tub**



CAUTION

Hazardous chemical.

Can cause personal injury.

- Do not splash the detergent solution in eyes. Wear rubber gloves to avoid prolonged detergent contact with skin.
- Keep detergent and solution out of reach of children.

NOTE: Always wash the cell(s) first, then the prefilter to keep heavy lint from getting caught in the cell(s).

STEP 1

Use a container, such as a laundry tub or trash container, that is large enough to hold one or both cell(s).

NOTE: Sharp corners on the cell(s) can scratch the surface of a bath tub.

STEP 2

Dissolve about 3/4 cup of automatic dish-washing detergent per cell in enough hot water to cover the cell(s). If the detergent does not dissolve readily, or forms a scum on the water, try another brand, or use softened water.

STEP 3

After the detergent has completely dissolved, place the cell(s) in the container and let them soak for 15 to 20 minutes. Agitate them up and down a few times, and remove.

STEP 4

Next, wash the prefilter the same way. Empty and rinse the wash container.

STEP 5

Rinse the cell(s) and prefilter with a hard spray of very hot water; rinse the tub clean, then fill the tub with clean hot water and soak for 5 to 15 minutes. Rinse until the water draining from the cell(s) and prefilter no longer feels slippery.

STEP 6

Wipe the ionizer wires and contact board on the end of the cell with a clean cloth.

**Washing the cell(s)
at a car wash**

Use the hand sprayer at a coin-operated do-it-yourself car wash to wash the cell(s) and prefilter. Hold the nozzle at least two feet away from the unit to avoid damage from the high pressure stream of water. Follow the same sequence of wash and rinse as recommended for cars; however, do not wax the cell(s) or the prefilter. Be sure to rinse until the water draining from the cell(s) and prefilter no longer feels slippery.

**Cleaning
lint and dust
accumulation
on door**

Just as with a conventional return air grille, lint and dust will collect on the grille and door of your electronic air cleaner. This can be removed during normal house cleaning by dusting or by using the brush attachment on your vacuum cleaner. If the door becomes stained, so that it cannot be cleaned by dusting, the door can be removed and soaked in a tub, or wiped clean using a mild spray cleaner.

**Replacing air
cleaner components****STEP 1**

Inspect the cell(s) for broken ionizer wires and bent collector plates. Repair as necessary or take to a Honeywell authorized air cleaner repair station.

STEP 2

It is very important that the electronic cell(s) be properly replaced:

- a. Electrical contact board *must face* the power supply contacts.
- b. Airflow arrows on the cell(s) must point into the air duct.
- c. Hook the cell(s) on the metal hooks and rotate into the air cleaner.
- d. Rotate the cell latch to secure the cell(s).

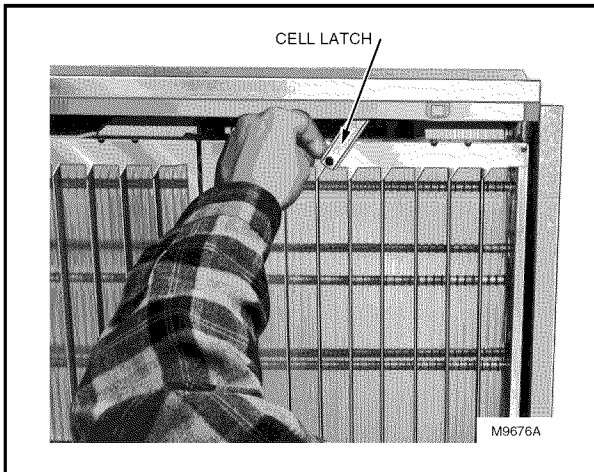

STEP 3

Slide the prefilter into the U-shaped channel and push the other end past the spring clip.

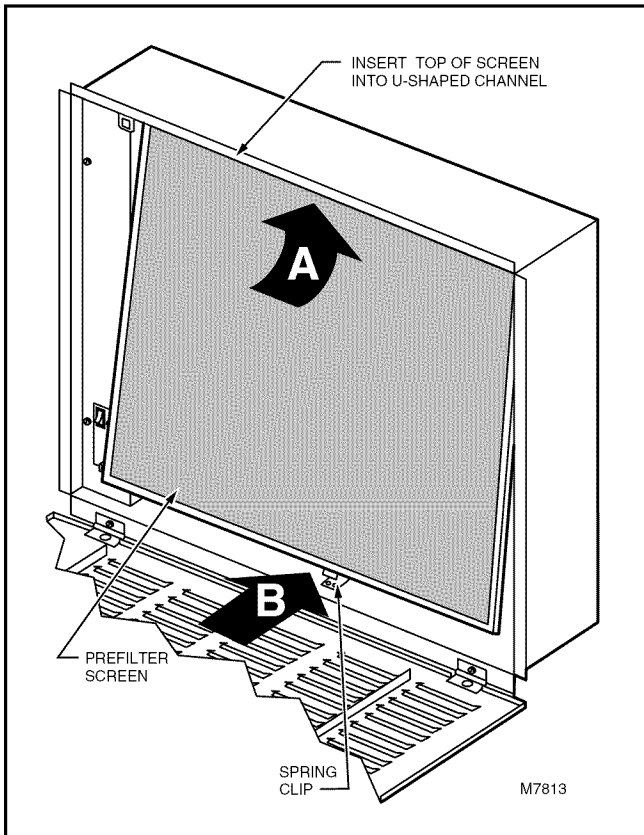

STEP 4

Close the door and fasten it with the two door latches.

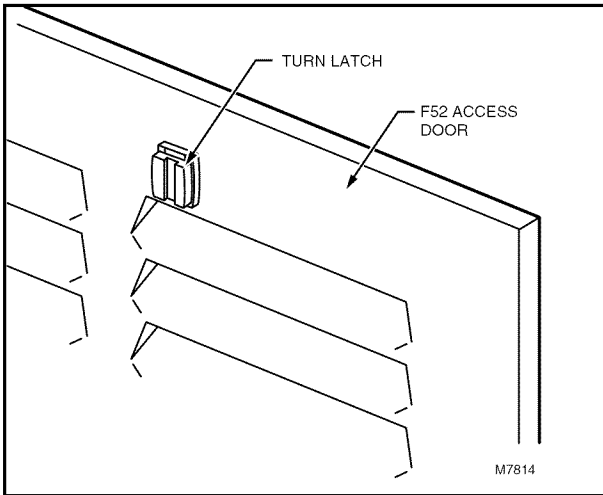

STEP 5

Turn on system fan. If the cell(s) and prefilter are wet, the neon light may not come on and you may hear arcing. If the arcing is annoying, simply turn off the air cleaner for 2 to 3 hours or until the cell(s) are dry.

If your air cleaner has a Solid State Performance Indicator, the CHECK LED may come on if you install wet cell(s) and prefilter. Again, if the neon light or the CHECK LED annoys you, simply turn off the air cleaner for 2 to 3 hours or until the cell(s) and prefilter are dry.

HOW ELECTRONIC AIR CLEANING WORKS

A word about particle size

The particles removed by the electronic air cleaner tend to be very small—less than ten microns. But what is a 10 micron particle? The eye of an average sized sewing needle has a diameter of about 750 microns, and the dot in the “i” in the word micron is about 400 microns. Generally, particles smaller than ten microns can be seen only with a microscope, except in very large concentrations such as a puff of smoke. Your electronic air cleaner can remove even smaller particles that can be seen only with an electron microscope.

Although particles one micron and smaller make up only about 20 percent of the total *weight* of particles in unfiltered air, they account for more than 99 percent of the *numbers* of particles.

Because they are so tiny, these particles tend to remain suspended in the air unless they collide with a solid surface. Then they attach by molecular adhesion and stick like glue, staining walls and furniture and coating your air conditioning coils. And, of course, some of these particles can cause allergic reactions or simply make the environment less pleasant.

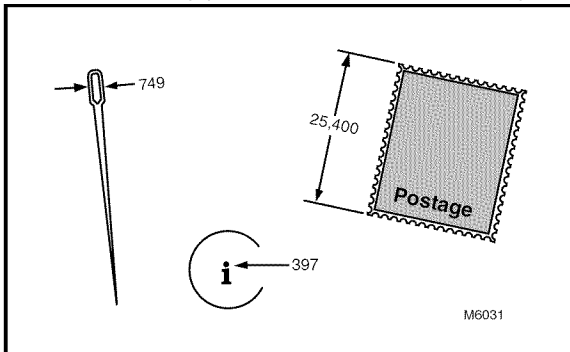

How the air cleaner works

First, large particles (lint, hair) are caught by the prefilter. Then, as the dirty air passes through the intense high voltage electric field surrounding the ionizer wires, all particles, even the smallest particles down to 0.5 microns, are given an electric charge. The air then passes into the collector where the alternate parallel plates are charged positive and negative, creating a uniform electrostatic field. The charged particles stick to the collector plates. The air leaving the air cleaner contains very few particles.

Each time the air circulates through the heating/air conditioning system and air cleaner, more particles are removed. These particles are generated by normal household activities, and also enter the house from outside. That is why we recommend that you use the air cleaner as much as possible.

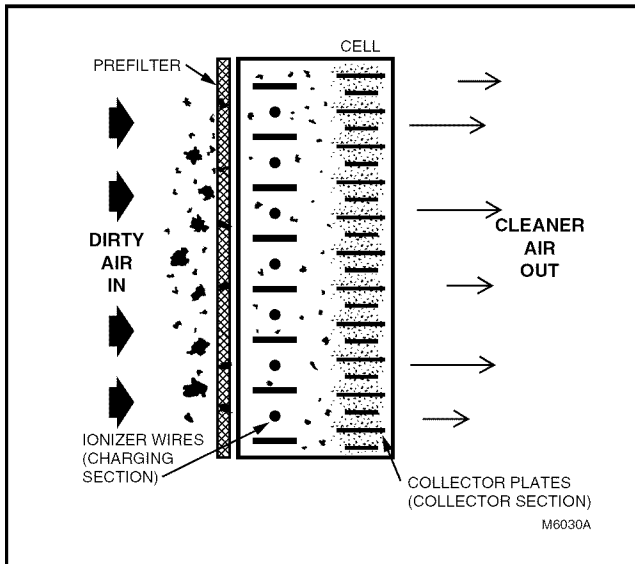

**The air cleaner
vs. the standard
furnace filter**

The regular furnace filter collects mainly large, visible particles that reach the filter. Its main purpose is to protect the furnace and air conditioner blower. The electronic air cleaner collects these large particles, plus many of the smaller, mostly invisible particles. Its purpose is to reduce indoor air pollution and to protect the blower, air conditioning coils and heat exchanger.

**The air cleaner
vs. the air
ionizer**

Air ionizers have been marketed with claims about purifying the air and promising medical benefits. It should be noted that supporting tests, if available, are controversial and incomplete.

Air ionizers can generate a bit of ozone, and can generate some ions (bits of material carrying some electricity). This is what your electronic air cleaner's ionizer does, but with greater intensity; however, air ionizers do not have good collectors, if any. With air ionizers, the contamination is emitted all over walls and floors, requiring frequent cleaning of the entire building to remove the effects of collected contamination. By comparison, an electronic air cleaner deposits contamination on the cell(s) and prefilter for easy cleaning.

Another benefit of an electronic air cleaner is that it reduces excessive positive or negative ions in the air, while an air ionizer generates some ions.

**Ozone and the
electronic
air cleaner**

Electronic air cleaners generate a very small amount of ozone, about 0.005 to 0.010 parts per million (ppm). The amount is highest when the air cleaner is new.

The average person can detect the odor of ozone in concentrations as low as 0.003 to 0.010 ppm. The U.S. Food and Drug Administration, and Health and Welfare Canada recommend that indoor ozone concentration should not exceed 0.050 ppm. As a comparison, the outdoor ozone level in major cities is sometimes as high as 0.100 ppm.

If desired, the ozone generated by the air cleaner can be reduced by asking your dealer to adjust the air cleaner power supply to reduce ozone production. This adjustment will reduce ozone production about 20 to 25 percent, but will also reduce air cleaning efficiency about 7 to 10 percent.

**About lint or
“white dust”**

White dust is made up of particles that settle out of the air before they get to the return air duct. You can help prevent this white dust from settling by running your fan constantly. Also:

- Be sure the discharge ducts are clean (best done before installing the air cleaner).
- Be sure your clothes dryer is vented to the outside and is not plugged.
- If you have new rugs or drapes or new woolen blankets, be aware that the lint from these items reduces with age.
- In new or remodeled homes, plaster dust or paint pigment may contribute to “white dust”, but reduces with time.

BEFORE YOU CALL FOR SERVICE

If your air cleaner is equipped with the optional W8600E Solid State Performance Indicator, the WASH and CHECK LEDs on the W8600E will remind you that cell and prefilter washing is past due and tell you when the system is not operating properly. Whether or not your air cleaner has a Solid State Performance Indicator, perform these checks before you call your heating and air conditioning dealer for service.

IF...

Air cleaner doesn't seem to be working

THEN...

1. Make sure the switch is in the ON position.
2. Make sure the air cleaner fuse or circuit breaker is ok.
3. Make sure the furnace or air conditioner blower is running.
4. Make sure the access door is closed and securely latched. If the door is not closed, an interlock keeps the air cleaner OFF.
5. Check the neon light; if on, air cleaner is operating properly; if off, call for service.

Arcing (snapping) seems too frequent

1. If the electronic cell(s) are wet from washing, turn off the air cleaner for 2 to 3 hours.
2. Check the cell(s) for broken ionizer wires or bent plates. Repair if necessary.
3. Wash cell(s) and prefilter if dirty.

**The neon light
on the air cleaner
doesn't come on**

1. Make sure the furnace or air conditioner blower is running.
2. On models without the Solid State Performance Indicator, if the electronic cells are wet, check again in 2 to 3 hours.
3. Make sure the appropriate fuse or circuit breaker is ok.

**The WASH LED
on the W8600E
comes on**

1. Cell and prefilter washing is past due; wash as soon as possible.
2. Make sure cell(s) are correctly installed in air cleaner.
3. Wipe ionizer wires to remove deposits.
NOTE: Use the wash reminder schedule to establish a washing schedule that prevents the WASH LED from coming on.

**The CHECK
LED on the
W8600E comes on**

1. Make sure cell(s) are clean and dry.
2. Check cell(s) for visible damage.

**You smell ozone
and find it
objectionable**

Call your heating and air conditioning dealer.

HONEYWELL 10 YEAR CLEAN COIL GUARANTEE

Guarantee

Honeywell guarantees your indoor heating/cooling coil will maintain optimum efficiency and energy savings for a minimum of ten years if your new Honeywell Electronic Air Cleaner is installed and properly maintained^a on either:

- A *new* heat pump, air conditioner, or high efficiency furnace, or
- A heat pump, air conditioner, or high efficiency furnace that is less than *one year old*, or
- A heat pump, air conditioner, or high efficiency furnace more than one year old that has had the indoor coil *professionally cleaned by a qualified heating/cooling contractor* prior to installing a Honeywell Electronic Air Cleaner.

If your coil requires cleaning within the next ten years, Honeywell will pay 50 percent of the cost to have the coil professionally cleaned by a qualified heating/cooling contractor, or \$100, whichever is less.

^aMaintain electronic air cleaner by keeping power switch in the ON position, and periodically verifying proper operation by checking the neon light. Wash cell(s) regularly, as specified in the owner's guide.

How to register your guarantee

You can register your guarantee by filling out the Clean Coil Guarantee Registration Card on the back cover. If the card has been misplaced, follow registration instructions below. After Honeywell receives your registration, it will be filed; no confirmation will be sent.

To register your guarantee, you'll need a copy of your dealer invoice showing purchase of a Honeywell F50, F52 or F58 Electronic Air Cleaner. You will also need dealer invoice(s) verifying the purchase of new heating/cooling equipment, or coil cleaning on existing equipment. The registration procedure differs for new and existing equipment.

...on new equipment or equipment less than one year old

For Honeywell Electronic Air Cleaners installed on a heat pump, air conditioner or high efficiency furnace that is either *new or less than one year old*, send copies of invoices verifying:

- Purchase of a new Honeywell Electronic Air Cleaner.
- Purchase of a heat pump, air conditioner or high efficiency furnace that is new or less than one year old.

...in newly constructed homes

Honeywell recognizes that in some newly constructed homes (those built within the previous 12 months), a Honeywell Electronic Air Cleaner may have already been installed, with no invoice available. In that case, register your guarantee by sending in:

- Name, address and phone number of the home builder.
- Approximate date home was completed.
- Date you moved in.

...on existing equipment more than one year old

For Honeywell Electronic Air Cleaners installed on a heat pump, air conditioner or high efficiency furnace that is *more than one year old*, send copies of invoices verifying:

- Proof of purchase of a new Honeywell Electronic Air Cleaner.
- Proof of purchase of a professional coil cleaning by a qualified heating/cooling contractor.

Save Even More Energy With These Honeywell Accessories

A Honeywell Chronotherm® Programmable Thermostat can save you 9 to 30 percent in heating and cooling costs—not just the first year, but every year!

- Can be programmed to automatically raise and lower home temperatures.
- Makes energy savings convenient.
- Optimizes your comfort.

If you have a standing pilot heating system less than 7 to 10 years old, you can stay comfortable and save even more. Team your new air cleaner and thermostat with Honeywell Electronic Ignition and an Automatic Vent Damper and save a total of up to 36% on energy costs for your gas furnace or boiler.

- Electronic Ignition ignites the pilot only when necessary to light the furnace.
- Automatic Vent Damper closes to trap useful heat inside the furnace or boiler after the burner shuts off. The additional heat stays *inside* the house, where it provides useful heat.

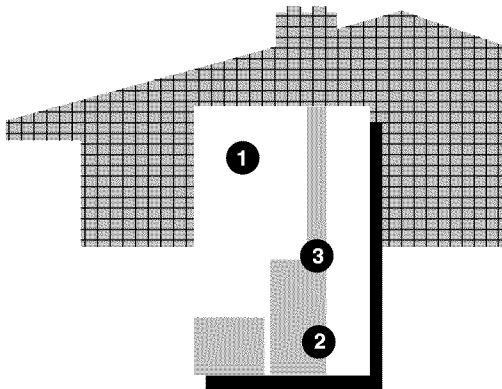

1. CHRONOTHERM® THERMOSTAT
2. ELECTRONIC IGNITION
3. AUTOMATIC VENT DAMPER

M10848

LIMITED TWO-YEAR WARRANTY

Honeywell warrants this product to be free from defects in the workmanship or materials, under normal use and service, for a period of two (2) years from the date of purchase by the consumer. If, at any time during the warranty period, the product is defective or malfunctions, Honeywell shall repair or replace it (at Honeywell's option) within a reasonable period of time.

If the product(s) is defective, please contact:

- a) the dealer from whom you purchased it, or
- b) the local Honeywell Authorized Repair Station, or
- c) the local Honeywell Residential Division Sales Office, or
- d) package the defective cell, power supply or other component with care, along with a bill of sale, receipt, or other dated proof of purchase, and a short description of the malfunction, and ship it, prepaid, to the following address:

Honeywell Return Goods
Dock 4 MN10-3860
Golden Valley, MN 55422

This warranty does not cover removal or reinstallation costs. This warranty shall not apply if it is shown by Honeywell that the defect or malfunction was caused by damage which occurred while the product was in the possession of a consumer.

Honeywell's sole responsibility shall be repair or replace the product within the terms stated above. HONEYWELL SHALL NOT BE LIABLE FOR ANY LOSS OR DAMAGE OF ANY KIND, INCLUDING ANY INCIDENTAL OR CONSEQUENTIAL DAMAGES RESULTING, DIRECTLY OR INDIRECTLY, FROM ANY BREACH OF ANY WARRANTY, EXPRESS OR IMPLIED, OR ANY OTHER FAILURE OF THIS PRODUCT. Some states do not allow the exclusion or limitation of incidental or consequential damages, so this limitation may not apply to you.

THE WARRANTIES SET FORTH HEREIN ARE EXCLUSIVE, AND HONEYWELL EXPRESSLY DISCLAIMS ALL OTHER WARRANTIES, WHETHER WRITTEN, ORAL, IMPLIED OR STATUTORY, INCLUDING BUT NOT LIMITED TO ANY WARRANTIES OF MERCHANTABILITY, WORKMANSHIP, OR FITNESS FOR A PARTICULAR PURPOSE.

This warranty gives you specific legal rights, and you may have other rights which vary from state to state.

If you have any questions concerning this warranty, please write to Home and Building Control Customer Relations, Honeywell, 1885 Douglas Drive, Minneapolis, MN 55422. In Canada, Honeywell Limited/Honeywell Limitée, 35 Dynamic Drive, Scarborough, Ontario M1V 4Z9.

Honeywell

Home and Building Control

Honeywell Inc.

Honeywell Plaza

P.O. Box 524

Minneapolis, MN 55408-0524

69-0419—2 L.C. Rev. 2-98



Printed in U.S.A. on recycled
paper containing at least 10%
post-consumer paper fibers.

[www.honeywell.com/
yourhome](http://www.honeywell.com/yourhome)