

**Honeywell**

# UV100E Ultraviolet System

OWNER'S GUIDE

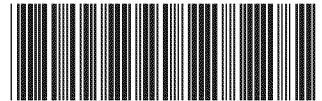
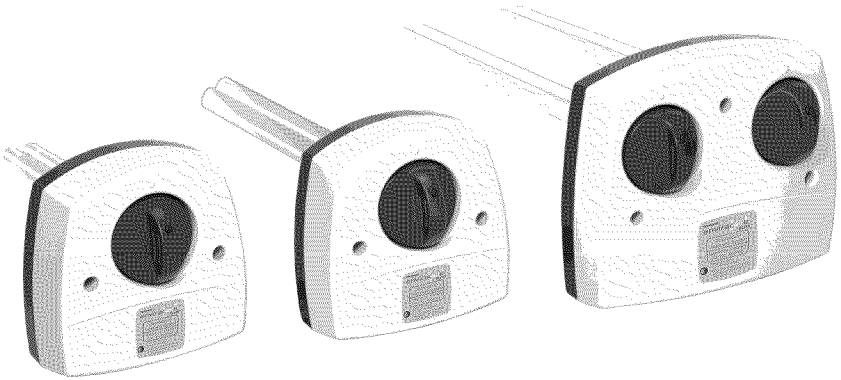

69-1573-3

**IMPORTANT**

*Please read these instructions and keep them in your records.*

## HOW YOUR ULTRAVIOLET AIR TREATMENT SYSTEM OR SURFACE TREATMENT SYSTEM WORKS

Your UV System uses patented SmartLamp™ control technology that monitors the HVAC system to operate the lamp only when needed. This technology extends bulb life up to five times and reduces power consumption, lowering operating costs. Your UV System also includes protection from extreme conditions that may be found in your heating and cooling system and local diagnostics with the SmartLamp™ LED and reset capability.

Depending on installation, your UV System can operate as an Air Treatment System or as a Surface Treatment System.

### Air Treatment System

Installed in the return air duct of your system, your Ultraviolet Air Treatment System kills a high percentage of airborne germs circulating through your forced air heating and cooling system. Individual results depend on careful installation and maintenance and on the actual amount of time your system fan operates. See Fig. 1.

Your Ultraviolet Air Treatment System uses the on-board air flow sensor or input from the Enviracom™ communication terminals to monitor air flowing through your heating and cooling system. The UV system turns on when air is flowing and leaves the lamp on for 40 minutes after the airflow stops. If airflow resumes during the 40 minutes, the timer resets to 40 minutes. When no airflow is detected for 40 minutes, the lamp turns off until the next occurrence of airflow.

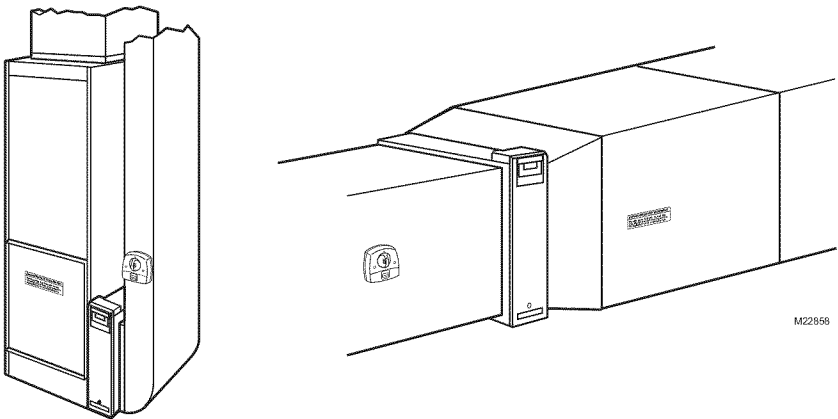
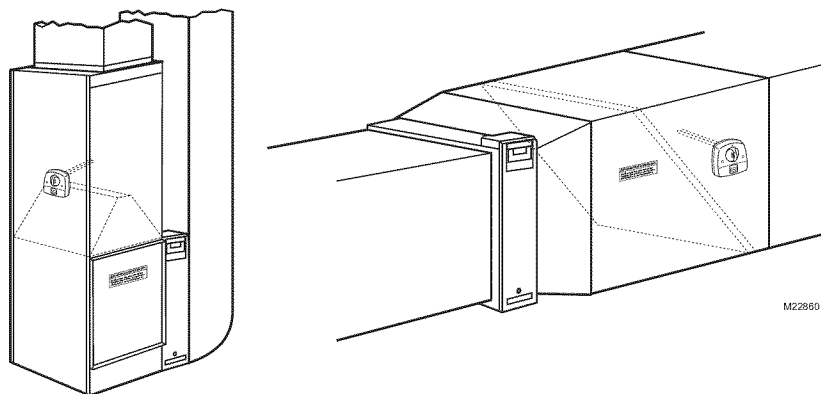

**Fig. 1. Typical Air Treatment System installations.**

## Surface Treatment System

When installed next to the cooling coil of your system, your Ultraviolet Surface Treatment System prevents a high percentage of the growth of micro-organisms such as mold that may grow on duct surfaces, coils, and drain pans. Individual results depend on careful installation and maintenance. See Fig. 2.

Your Ultraviolet Surface Treatment System operates a steady three-hours-on/ three-hours-off cycle. With Enviracom™ communication terminals hooked up, your UV System turns off for the Winter 30 days after the last call for cooling occurs. And your UV System turns on and resumes the on/off cycle with the first call for cooling in the Spring.



**Fig. 2. Typical Surface Treatment System installations.**

You can capture and minimize micro-organisms passing through your forced air system when you combine your UV System with a high-efficiency air filtration system like an electronic air cleaner. Talk to your installer about adding an electronic air cleaner to complement your UV System and provide added protection for you and your family.

### Enviracom™ Communications Capabilities:

- Communicates with homeowner through three-wire communication bus using 24 Vac thermostat connections.
  - *Hooked up to Air Treatment System (single-bulb and dual-bulb) models:* uses thermostat load information instead of airflow sensor.
  - *Hooked up to Surface Treatment System model:* uses thermostat load information to operate during times evaporator coil may be exposed to moisture to extend lamp life beyond two years.
- Sends messages to communicate reset and receives remote reset, when available.
  - Bulb change indication cannot be reset by cycling power.
  - When Enviracom is transmitting messages, shows flashing green Enviracom LED on bottom of unit.

When Enviracom is transceiving messages, shows solid green Enviracom LED on bottom of unit.

# BE SURE TO READ WARNINGS AND CAUTIONS BEFORE USING YOUR UV SYSTEM



## **WARNING**

### **UV Light Hazard.**

**Harmful to bare skin and eyes.**

**Can cause temporary or permanent loss of vision.**

Never look at bulbs while illuminated.

View illumination only through light indicator located on lamp handle.

To prevent exposure to ultraviolet light, disconnect power to Ultraviolet System before servicing any part of heating and air conditioning system.

Do not mount device in location that allows ultraviolet light to be seen after installation.

Do not attempt to bypass duct mount switch.

Do not attempt to open housing; unit is sealed to prevent ultraviolet light exposure.

## **CAUTION**

### **Personal Injury Hazard.**

**Power supply can cause electrical shock.**

Disconnect power supply before cleaning or replacing ultraviolet bulb(s).

Do not open base unit or lamp handle; there are no user-serviceable components inside.

## **CAUTION**

### **Breakable Glass Hazard.**

**Can cause personal injury.**

Be careful when inserting bulb(s) into lamp base.

Wear protective gloves when handling bulb(s).



## **CAUTION**

### **UV Lamp Burn Hazard.**

**Harmful to bare skin.**

**Can cause severe burns.**

Disconnect power 15 minutes before removing ultraviolet bulb(s).



## MERCURY NOTICE

This device contains mercury in the sealed ultraviolet bulb(s). Do not place your used bulb(s) in the trash. Dispose of properly.

### **Broken Bulb Cleanup.**

#### **Do not use a household vacuum.**

Sweep debris (phosphor/glass) into a plastic bag and dispose of properly. Contact your local waste management authority for instructions regarding recycling and the proper disposal of old bulb(s).

# HOW YOU CAN CHECK YOUR ULTRAVIOLET SYSTEM

Your UV System is designed to prevent accidental contact with electrical voltage and with ultraviolet rays in the sealed unit—the ultraviolet lamp does not illuminate unless the base is mounted on your forced air system duct.

It is recommended that every month you verify that your ultraviolet lamp is operating. *View the bulb only through the lamp light indicator on the lamp handle. See Fig. 3. Do not attempt to look into the duct at the illuminated bulb(s).*

If the light is not on when you check your UV System, briefly push the reset button for one second. This brings the lamp on for 40 minutes (Air Treatment System) or for 30 minutes (Surface Treatment System). Pressing the reset button for five seconds resets all internal timers. Cycling power does not reset the internal timers.

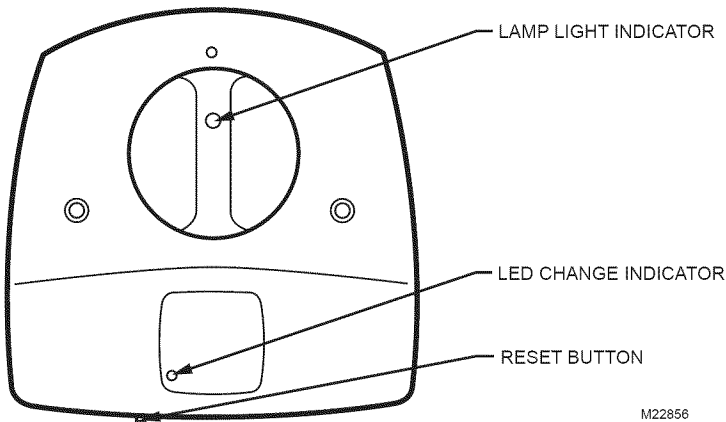

M22856

**Fig. 3. Lamp light indicator, LED change indicator and reset button.**

The LED indicator on the front of your UV System operates as follows:

LED Status	Indicates	Homeowner Action
Off	100 to 11% bulb life <sup>a</sup> remaining	Nothing
Flashing	10 to 1% bulb life <sup>a</sup> remaining	Purchases bulb(s)
Solid	0% bulb life <sup>a</sup> remaining	Replaces bulb(s)

<sup>a</sup>Bulb life means emitting adequate amount of UV-C energy to maintain an effective kill rate. At 0% bulb life remaining, the bulbs continue to operate until catastrophic bulb failure (bulb burns out) but the kill rate becomes rapidly negligible.

# HOW YOU CAN MAINTAIN YOUR UV SYSTEM

You should regularly clean your UV System to maintain peak effectiveness of your air treatment or surface treatment system. Replace the ultraviolet bulb when LED status light on the front of your UV System is on steadily.

## Quarterly Bulb Cleaning

Bulb cleaning is recommended as routine maintenance four times a year or every three months. Use the UV Bulb Cleaning Reminder Schedule, Fig. 4, to help establish and track your regular cleaning schedule.

### UV BULB CLEANING REMINDER SCHEDULE

INSTALLATION DATE: (month) \_\_\_\_\_, (year) \_\_\_\_\_

YEAR	J	F	M	A	M	J	J	A	S	O	N	D

M13516A

**Fig. 4. UV bulb cleaning reminder schedule.**

To clean your bulbs:

1. Disconnect the power to your heating and cooling system.
2. Unplug or turn off power to your UV System and allow the bulb to cool for at least 15 minutes.

3. Rotate your lamp handle counterclockwise and gently pull the lamp handle to remove the bulb. See Fig. 5.

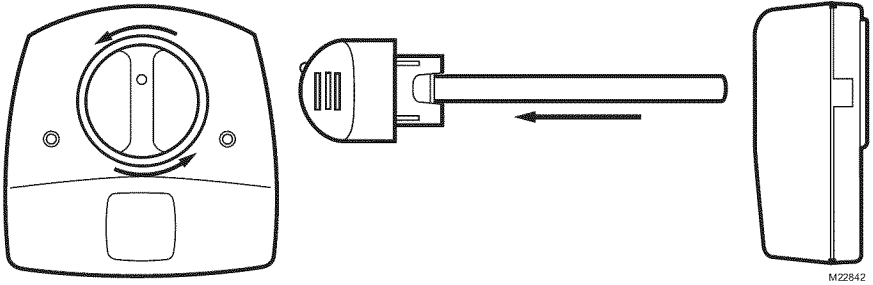

**Fig. 5. Remove lamp bulb.**

4. Holding the lamp handle, wipe the lamp glass using a soft cloth dampened with glass cleaner. If you touch the lamp glass with your hands, be sure to clean the area of any oils left from bare hands. See Fig. 6.

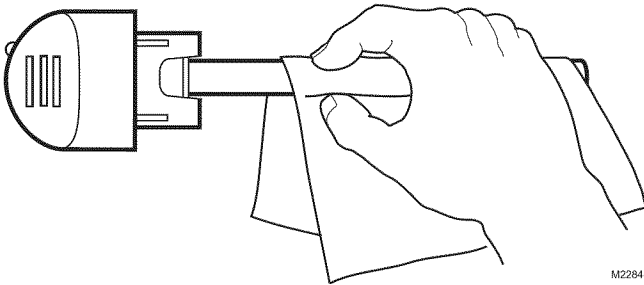

**Fig. 6. Clean glass with soft cloth.**

5. Also wipe away any dust that may have collected between the lamp light indicator base and the black bulb base. See Fig. 7.

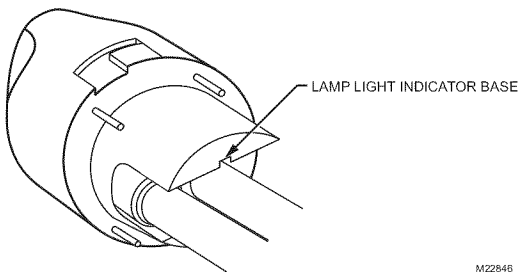

**Fig. 7. Wipe lamp light indicator base.**



6. Dry bulb with a clean, dry cloth.
7. Insert the bulb into the base with the lamp light indicator at the eleven o'clock position. Continue pushing and gently rotating counterclockwise until the lamp handle inserts fully into the base. See Fig. 8.

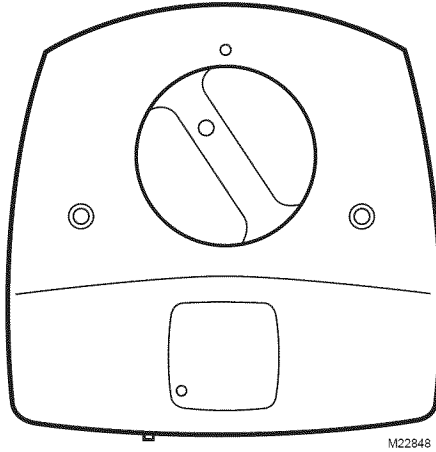

**Fig. 8. Position bulb for insertion back into the lamp base.**

8. Rotate the lamp handle clockwise until it snaps into place with the lamp light indicator aligned with the raised button on the unit cover. See Fig. 9.

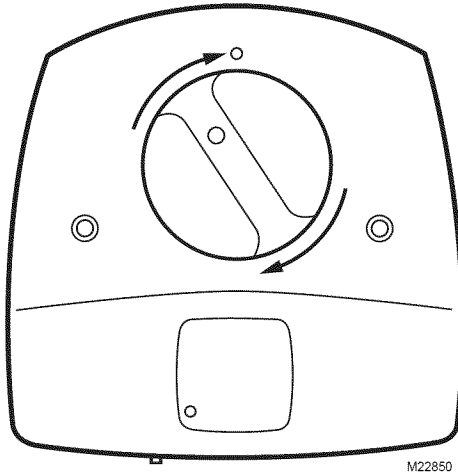

**Fig. 9. Snap bulb into place.**

## UV100E ULTRAVIOLET SYSTEM

9. Reconnect power to your UV System.
10. For UV Air Treatment Systems, wait ten minutes for the airflow sensor to calibrate. During this time, the furnace fan must remain off.

NOTE: Failure to wait ten minutes for the airflow sensor to calibrate before powering the system fan causes the airflow sensor to incorrectly calibrate and the device to incorrectly function. If this occurs, remove power to the furnace or turn off the system fan, wait ten minutes, and then resume normal fan operation.

11. Verify that your ultraviolet bulb is operating by viewing only through the lamp light indicator on the lamp handle. Never look directly at your bulb while it is illuminated.
12. Reconnect power to your heating and cooling system.

## Bulb Replacement

Replacement of the bulb in your ultraviolet lamp when the LED is solidly lighted is required to maintain effectiveness.

1. Obtain the correct replacement bulb/handle assembly or replacement bulb for your unit. See Table 1.

**Table 1. Select a Replacement Bulb/Handle Assembly or Replacement Bulb.**

Unit Description	Replacement Bulb/ Handle Assembly	SnapLamp™ Replacement Bulb
UV100E1043 Air Treatment System	UC100E1006	UC18W1004
UV100E2009 Air Treatment System	UC100E1030 (two needed)	UC36W1006 (two needed)
UV100E3007 Surface Treatment System	UC100E1030	UC36W1006

2. Disconnect the power to your heating and cooling system.
3. Unplug or turn off power to your UV System and allow the bulb to cool for at least 15 minutes.
4. Rotate the lamp handle counterclockwise and gently pull the lamp handle to remove the bulb. See Fig. 5.

- If you have a SnapLamp™ handle, follow steps 5 and 6; otherwise, proceed to step 7. Grasp the SnapLamp™ handle in one hand and the lamp glass in the other and pull straight apart. See Fig. 10.

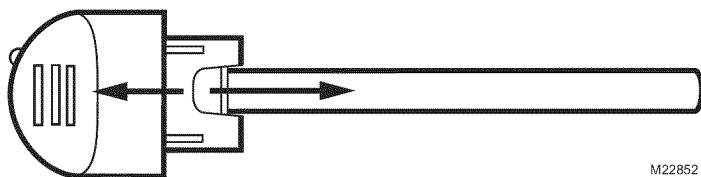

M22852

**Fig. 10. Disconnect lamp glass from SnapLamp™ handle.**

- Insert the new lamp glass into the SnapLamp™ handle by aligning the key and pushing straight together. See Fig. 11.

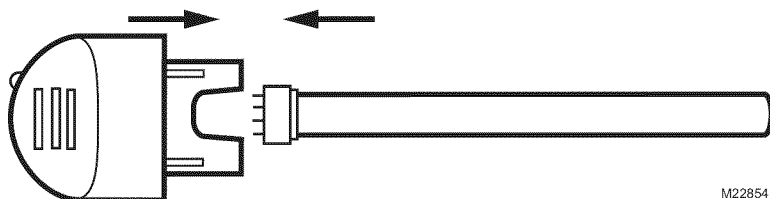

M22854

**Fig. 11. Replace lamp glass in SnapLamp™ handle.**

- Insert the bulb into the base with the lamp light indicator at the eleven o'clock position. Continue pushing and gently rotating counterclockwise until the lamp handle inserts fully into the base. See Fig. 8.
- Rotate the lamp clockwise until it snaps into place with the lamp light indicator aligned with the raised button on the unit cover. See Fig. 9.
- Reconnect power to your UV System.
- For UV Air Treatment Systems, wait ten minutes for the airflow sensor to calibrate. During this time, the furnace fan must remain off.

**NOTE:** Failure to wait ten minutes for the airflow sensor to calibrate before powering the system fan causes the airflow sensor to incorrectly calibrate and the device to incorrectly function. If this occurs, remove power to the furnace or turn off the system fan, wait ten minutes, and then resume normal fan operation.

- Verify that your ultraviolet bulbs are operating by viewing only through the lamp light indicator on the lamp handle. Never look directly at your bulbs while illuminated.
- Reconnect power to your heating and cooling system.
- Press and hold the reset button for five seconds to reset the internal timers.

## Five-Year Limited Warranty

Honeywell warrants this product, excluding bulbs, to be free from defects in the workmanship or materials, under normal use and service, for a period of five (5) years from the date of purchase by the consumer. If, at any time during the warranty period, the product is defective or malfunctions, Honeywell shall repair or replace it (at Honeywell's option) within a reasonable period of time.

If the product is defective,

- (i) return it, with a bill of sale or other dated proof of purchase, to the retailer from which you purchased it, or
- (ii) package it carefully, along with proof of purchase (including date of purchase) and a short description of the malfunction, and mail it, postage prepaid, to the following address:  
Honeywell Return Goods  
Dock 4 MN10-3860  
1885 Douglas Dr. N  
Golden Valley, MN 55422

This warranty does not cover removal or reinstallation costs. This warranty shall not apply if it is shown by Honeywell that the defect or malfunction was caused by damage which occurred while the product was in the possession of a consumer.

Honeywell's sole responsibility shall be to repair or replace the product within the terms stated above. HONEYWELL SHALL NOT BE LIABLE FOR ANY LOSS OR DAMAGE OF ANY KIND, INCLUDING ANY INCIDENTAL OR CONSEQUENTIAL DAMAGES RESULTING, DIRECTLY OR INDIRECTLY, FROM ANY BREACH OF ANY WARRANTY, EXPRESS OR IMPLIED, OR ANY OTHER FAILURE OF THIS PRODUCT. Some states do not allow the exclusion or limitation of incidental or consequential damages, so this limitation may not apply to you.

THIS WARRANTY IS THE ONLY EXPRESS WARRANTY HONEYWELL MAKES ON THIS PRODUCT. THE DURATION OF ANY IMPLIED WARRANTIES, INCLUDING THE WARRANTIES OF MERCHANTABILITY AND FITNESS FOR A PARTICULAR PURPOSE, IS HEREBY LIMITED TO THE FIVE YEAR DURATION OF THIS WARRANTY. Some states do not allow limitations on how long an implied warranty lasts, so the above limitation may not apply to you.

This warranty gives you specific legal rights, and you may have other rights which vary from state to state.

If you have any questions concerning this warranty, please write Honeywell Customer Relations, Honeywell, 1985 Douglas Dr. N MN10-1461, Golden Valley, MN 55422. In Canada, write Retail Products ON15-02H, Honeywell Limited/Honeywell Limitée, 35 Dynamic Drive, Toronto, Ontario, M1V4Z9.

## Automation and Control Solutions

Honeywell International Inc.    Honeywell Limited-Honeywell Limitée  
1985 Douglas Drive North    35 Dynamic Drive  
Golden Valley, MN 55422    Toronto, Ontario M1V 4Z9  
yourhome.honeywell.com



Printed in U.S.A. on recycled paper containing at least 10% post-consumer paper fibers.