

OPERATOR'S MANUAL

CRAFTSMAN[®]

1/2 in. DRILL

VARIABLE SPEED / REVERSIBLE

DOUBLE INSULATED

Model No.

315.101150

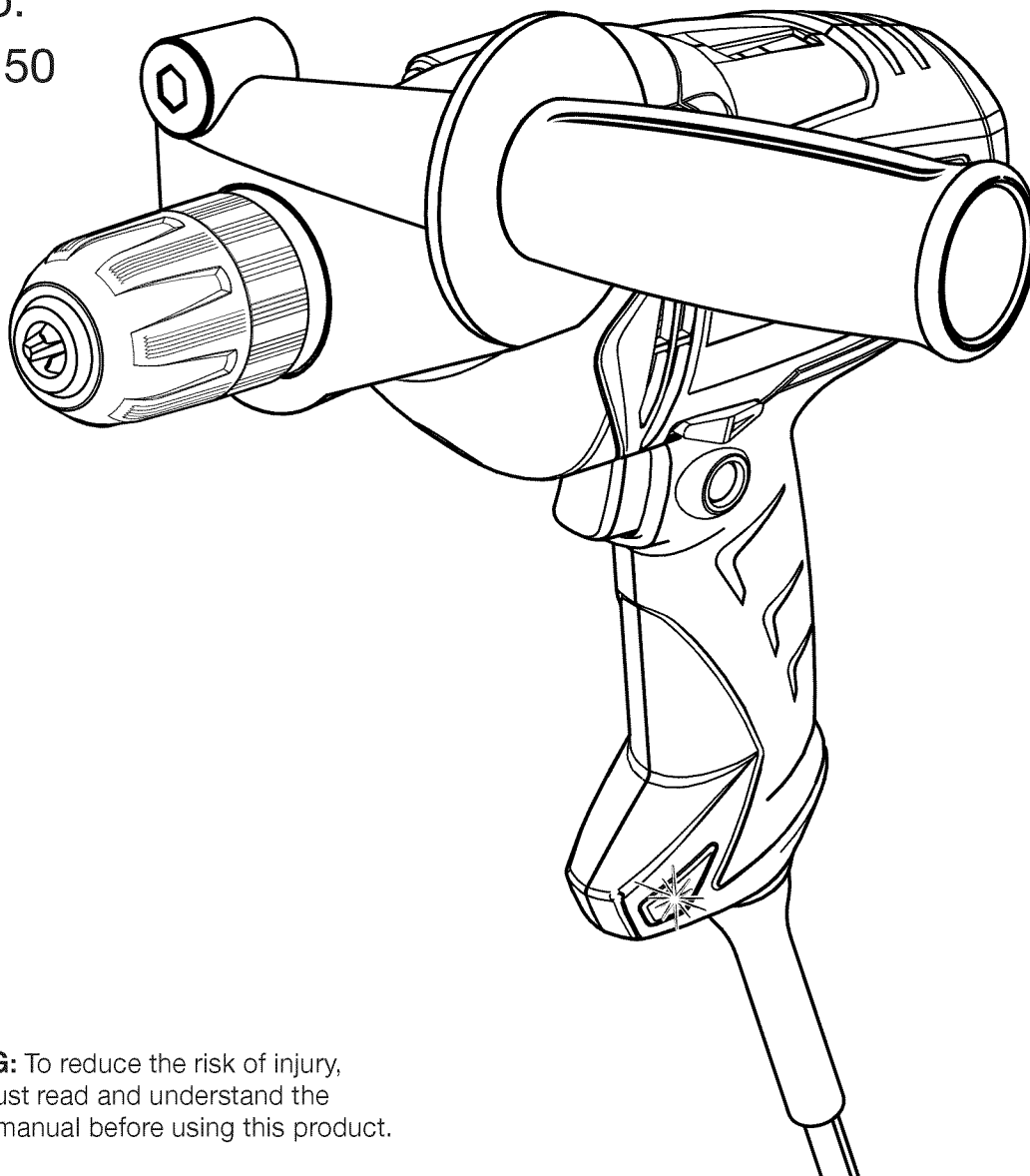

⚠ WARNING: To reduce the risk of injury, the user must read and understand the operator's manual before using this product.

Customer Help Line: 1-800-932-3188

Sears, Roebuck and Co., 3333 Beverly Rd., Hoffman Estates, IL 60179 USA

Visit the Craftsman web page: www.sears.com/craftsman

983000-741
09-28-06 (REV:01)

Save this manual for future reference



TABLE OF CONTENTS

■ Warranty	2
■ Introduction	2
■ General Safety Rules	3-4
■ Specific Safety Rules	4
■ Symbols	5-6
■ Electrical	7
■ Features	8
■ Assembly	9
■ Operation	9-13
■ Maintenance	14-15
■ Accessories	15
■ Exploded View and Parts List	16
■ Parts Ordering/Service	Back Page

WARRANTY

ONE YEAR FULL WARRANTY ON CRAFTSMAN TOOL

If this Craftsman tool fails to give complete satisfaction within one year from date of purchase, **RETURN IT TO THE NEAREST SEARS STORE IN THE UNITED STATES**, and Sears will replace it, free of charge.

If this Craftsman tool is used for commercial or rental purposes, this warranty applies for only 90 days from the date of purchase.

This warranty gives you specific legal rights, and you may also have other rights which vary from state to state.

Sears, Roebuck and Co., Dept. 817 WA, Hoffman Estates, IL 60179

INTRODUCTION

This tool has many features for making its use more pleasant and enjoyable. Safety, performance, and dependability have been given top priority in the design of this product making it easy to maintain and operate.

GENERAL SAFETY RULES

⚠ WARNING! Read all instructions. Failure to follow all instructions listed below may result in electric shock, fire and/or serious injury. The term “power tool” in all of the warnings listed below refers to your mains-operated (corded) power tool or battery-operated (cordless) power tool.

SAVE THESE INSTRUCTIONS

WORK AREA SAFETY

- **Keep work area clean and well lit.** Cluttered or dark areas invite accidents.
- **Do not operate power tools in explosive atmospheres, such as in the presence of flammable liquids, gases, or dust.** Power tools create sparks which may ignite the dust or fumes.
- **Keep bystanders, children, and visitors away while operating a power tool.** Distractions can cause you to lose control.

ELECTRICAL SAFETY

- **Power tool plugs must match the outlet. Never modify the plug in any way. Do not use any adapter plugs with earthed (grounded) power tools.** Unmodified plugs and matching outlets will reduce risk of electric shock.
- **Avoid body contact with earthed or grounded surfaces such as pipes, radiators, ranges and refrigerators.** There is an increased risk of electric shock if your body is earthed or grounded.
- **Do not expose power tools to rain or wet conditions.** Water entering a power tool will increase the risk of electric shock.
- **Do not abuse the cord. Never use the cord for carrying, pulling or unplugging the power tool. Keep cord away from heat, oil, sharp edges or moving parts.** Damaged or entangled cords increase the risk of electric shock.
- **When operating a power tool outdoors, use an extension cord suitable for outdoor use.** Use of a cord suitable for outdoor use reduces the risk of electric shock.

PERSONAL SAFETY

- **Stay alert, watch what you are doing and use common sense when operating a power tool. Do not use a power tool while you are tired or under the influence of drugs, alcohol or medication.** A moment of inattention while operating power tools may result in serious personal injury.
- **Use safety equipment. Always wear eye protection.** Safety equipment such as dust mask, non-skid safety shoes, hard hat, or hearing protection used for appropriate conditions will reduce personal injuries.
- **Avoid accidental starting. Ensure the switch is in the off-position before plugging in.** Carrying power tools with your finger on the switch or plugging in power tools that have the switch on invites accidents.

- **Remove any adjusting key or wrench before turning the power tool on.** A wrench or a key left attached to a rotating part of the power tool may result in personal injury.
- **Do not overreach. Keep proper footing and balance at all times.** This enables better control of the power tool in unexpected situations.
- **Dress properly. Do not wear loose clothing or jewelry. Keep your hair, clothing and gloves away from moving parts.** Loose clothes, jewelry or long hair can be caught in moving parts.
- **If devices are provided for the connection of dust extraction and collection facilities, ensure these are connected and properly used.** Use of these devices can reduce dust-related hazards.
- **Do not wear loose clothing or jewelry. Contain long hair.** Loose clothes, jewelry, or long hair can be drawn into air vents.
- **Do not use on a ladder or unstable support.** Stable footing on a solid surface enables better control of the power tool in unexpected situations.

POWER TOOL USE AND CARE

- **Do not force the power tool. Use the correct power tool for your application.** The correct power tool will do the job better and safer at the rate for which it was designed.
- **Do not use the power tool if the switch does not turn it on and off.** Any power tool that cannot be controlled with the switch is dangerous and must be repaired.
- **Disconnect the plug from the power source and/or the battery pack from the power tool before making any adjustments, changing accessories, or storing power tools.** Such preventive safety measures reduce the risk of starting the power tool accidentally.
- **Store idle power tools out of the reach of children and do not allow persons unfamiliar with the power tool or these instructions to operate the power tool.** Power tools are dangerous in the hands of untrained users.
- **Maintain power tools. Check for misalignment or binding of moving parts, breakage of parts and any other condition that may affect the power tool’s operation. If damaged, have the power tool repaired before use.** Many accidents are caused by poorly maintained power tools.
- **Keep cutting tools sharp and clean.** Properly maintained cutting tools with sharp cutting edges are less likely to bind and are easier to control.
- **Use the power tool, accessories and tool bits etc., in accordance with these instructions and in the manner intended for the particular type of power tool, taking into account the working conditions and the work to be performed.** Use of the power tool for operations different from those intended could result in a hazardous situation.

GENERAL SAFETY RULES

SERVICE

- **Have your power tool serviced by a qualified repair person using only identical replacement parts.** This will ensure that the safety of the power tool is maintained.
- **When servicing a power tool, use only identical replacement parts. Follow instructions in the**

Maintenance section of this manual. Use of unauthorized parts or failure to follow Maintenance instructions may create a risk of shock or injury.



WARNING! To reduce the risk of injury, user must read instruction manual.

SPECIFIC SAFETY RULES

- **Use auxiliary handles supplied with the tool.** Loss of control can cause personal injury.
- **Hold power tool by insulated gripping surfaces when performing an operation where the cutting tool may contact hidden wiring or its own cord.** Contact with a “live” wire will make exposed metal parts of the tool “live” and shock the operator.
- **Know your power tool. Read operator’s manual carefully. Learn its applications and limitations, as well as the specific potential hazards related to this tool.** Following this rule will reduce the risk of electric shock, fire, or serious injury.
- **Always wear safety glasses. Everyday eyeglasses have only impact-resistant lenses; they are NOT safety glasses.** Following this rule will reduce the risk of serious personal injury.
- **Protect your lungs. Wear a face or dust mask if the operation is dusty.** Following this rule will reduce the risk of serious personal injury.
- **Protect your hearing. Wear hearing protection during extended periods of operation.** Following this rule will reduce the risk of serious personal injury.
- **Inspect tool cords periodically and, if damaged, have repaired at your nearest Authorized Service Center. Constantly stay aware of cord location.** Following this rule will reduce the risk of electric shock or fire.
- **Check damaged parts. Before further use of the tool, a guard or other part that is damaged should be carefully checked to determine that it will operate properly and perform its intended function. Check for alignment of moving parts, binding of moving parts, breakage of parts, mounting, and any other conditions that may affect its operation. A guard or other part that is damaged should be properly repaired or replaced by an authorized service center.** Following this rule will reduce the risk of shock, fire, or serious injury.
- **Make sure your extension cord is in good condition. When using an extension cord, be sure to use one heavy enough to carry the current your product will draw. A wire gauge size (A.W.G.) of at least 14 is recommended for an extension cord 50 feet or less in length. A cord exceeding 100 feet is not recommended. If in doubt, use the next heavier gauge. The smaller the gauge number, the heavier the cord.** An undersized cord will cause a drop in line voltage resulting in loss of power and overheating.
- **Inspect for and remove all nails from lumber before using this tool.** Following this rule will reduce the risk of serious personal injury.
- **Save these instructions.** Refer to them frequently and use them to instruct others who may use this tool. If you loan someone this tool, loan them these instructions also.











 **WARNING:** Some dust created by power sanding, sawing, grinding, drilling, and other construction activities contains chemicals known to cause cancer, birth defects or other reproductive harm. Some examples of these chemicals are:

- lead from lead-based paints,
- crystalline silica from bricks and cement and other masonry products, and
- arsenic and chromium from chemically-treated lumber.

Your risk from these exposures varies, depending on how often you do this type of work. To reduce your exposure to these chemicals: work in a well ventilated area, and work with approved safety equipment, such as those dust masks that are specially designed to filter out microscopic particles.



SYMBOLS

Some of the following symbols may be used on this tool. Please study them and learn their meaning. Proper interpretation of these symbols will allow you to operate the tool better and safer.

SYMBOL	NAME	DESIGNATION/EXPLANATION
V	Volts	Voltage
A	Amperes	Current
Hz	Hertz	Frequency (cycles per second)
W	Watt	Power
min	Minutes	Time
~	Alternating Current	Type of current
==	Direct Current	Type or a characteristic of current
n_0	No Load Speed	Rotational speed, at no load
	Class II Construction	Double-insulated construction
.../min	Per Minute	Revolutions, strokes, surface speed, orbits etc., per minute
	Wet Conditions Alert	Do not expose to rain or use in damp locations.
	Read The Operator's Manual	To reduce the risk of injury, user must read and understand operator's manual before using this product.
	Eye Protection	Always wear safety goggles, safety glasses with side shields, or a full face shield when operating this product.
	Safety Alert	Precautions that involve your safety.
	No Hands Symbol	Failure to keep your hands away from the blade will result in serious personal injury.
	No Hands Symbol	Failure to keep your hands away from the blade will result in serious personal injury.
	No Hands Symbol	Failure to keep your hands away from the blade will result in serious personal injury.
	No Hands Symbol	Failure to keep your hands away from the blade will result in serious personal injury.
	Hot Surface	To reduce the risk of injury or damage, avoid contact with any hot surface.

SYMBOLS

The following signal words and meanings are intended to explain the levels of risk associated with this product.

SYMBOL	SIGNAL	MEANING
	DANGER:	Indicates an imminently hazardous situation, which, if not avoided, will result in death or serious injury.
	WARNING:	Indicates a potentially hazardous situation, which, if not avoided, could result in death or serious injury.
	CAUTION:	Indicates a potentially hazardous situation, which, if not avoided, may result in minor or moderate injury.
	CAUTION:	(Without Safety Alert Symbol) Indicates a situation that may result in property damage.

SERVICE

Servicing requires extreme care and knowledge and should be performed only by a qualified service technician. For service we suggest you return the product to your nearest **AUTHORIZED SERVICE CENTER** for repair. When servicing, use only identical replacement parts.



WARNING: To avoid serious personal injury, do not attempt to use this product until you read thoroughly and understand completely the operator's manual. Save this operator's manual and review frequently for continuing safe operation and instructing others who may use this product.

WARNING:



The operation of any power tool can result in foreign objects being thrown into your eyes, which can result in severe eye damage. Before beginning power tool operation, always wear safety goggles, safety glasses with side shields, or a full face shield when needed. We recommend Wide Vision Safety Mask for use over eyeglasses or standard safety glasses with side shields. Always use eye protection which is marked to comply with ANSI Z87.1.

SAVE THESE INSTRUCTIONS

ELECTRICAL

DOUBLE INSULATION

Double insulation is a concept in safety in electric power tools, which eliminates the need for the usual three-wire grounded power cord. All exposed metal parts are isolated from the internal metal motor components with protecting insulation. Double insulated tools do not need to be grounded.

⚠ WARNING: The double insulated system is intended to protect the user from shock resulting from a break in the tool's internal insulation. Observe all normal safety precautions to avoid electrical shock.

NOTE: Servicing of a tool with double insulation requires extreme care and knowledge of the system and should be performed only by a qualified service technician. For service, we suggest you return the tool to your nearest authorized service center for repair. Always use original factory replacement parts when servicing.

ELECTRICAL CONNECTION

This tool has a precision-built electric motor. It should be connected to a **power supply that is 120 volts, 60 Hz, AC only (normal household current)**. Do not operate this tool on direct current (DC). A substantial voltage drop will cause a loss of power and the motor will overheat. If your tool does not operate when plugged into an outlet, double-check the power supply.

EXTENSION CORDS

When using a power tool at a considerable distance from a power source, be sure to use an extension cord that has the capacity to handle the current the tool will draw. An undersized cord will cause a drop in line voltage, resulting in overheating and loss of power. Use the chart to determine the minimum wire size required in an extension cord. Only round jacketed cords listed by Underwriter's Laboratories (UL) should be used.

When working outdoors with a tool, use an extension cord that is designed for outside use. This type of cord is designated with "WA" on the cord's jacket.

Before using any extension cord, inspect it for loose or exposed wires and cut or worn insulation.

**Ampere rating (on tool faceplate)

0-2.0	2.1-3.4	3.5-5.0	5.1-7.0	7.1-12.0	12.1-16.0
-------	---------	---------	---------	----------	-----------

Cord Length	Wire Size (A.W.G.)					
25'	16	16	16	16	14	14
50'	16	16	16	14	14	12
100'	16	16	14	12	10	—

**Used on 12 gauge - 20 amp circuit

NOTE: AWG = American Wire Gauge

⚠ WARNING: Keep the extension cord clear of the working area. Position the cord so that it will not get caught on lumber, tools or other obstructions while you are working with a power tool. Failure to do so can result in serious personal injury.

⚠ WARNING: Check extension cords before each use. If damaged replace immediately. Never use tool with a damaged cord since touching the damaged area could cause electrical shock resulting in serious injury.

FEATURES

PRODUCT SPECIFICATIONS

Chuck	1/2 in. Keyless	No Load Speed	0-800/min.
Switch.....	Variable Speed/Reversible	Input	120 V, 60 Hz, AC only, 5.5 Amps
Maximum Torque.....	Maximum 266 in.lb.	Net Weight.....	5 lbs.

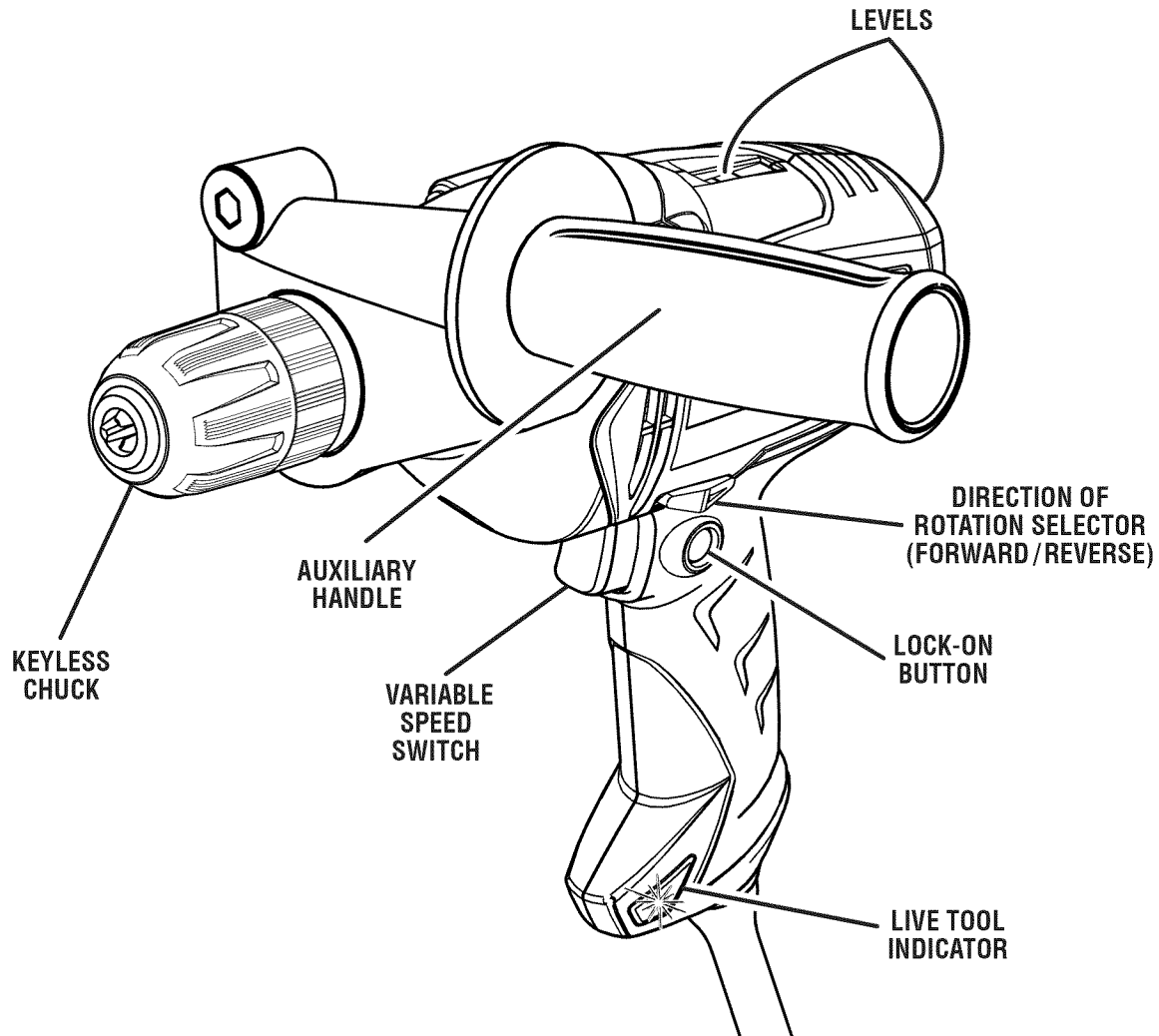

Fig. 1

KNOW YOUR DRILL

See Figure 1.

Before attempting to use this product, familiarize yourself with all operating features and safety rules.

AUXILIARY HANDLE

Your drill is equipped with an auxiliary handle for ease of operation and to prevent loss of control.

DIRECTION OF ROTATION SELECTOR (FORWARD/REVERSE)

Your drill has a direction of rotation (forward/reverse) selector located above the variable speed switch for changing the direction of bit rotation.

KEYLESS CHUCK

The keyless chuck allows you to hand-tighten or release the drill bit in the chuck jaws.

LIVE TOOL INDICATOR

The live tool indicator is located on the handle of the drill and indicates that the tool is connected to a power supply.

LOCK-ON BUTTON

The lock-on button is convenient for continuous drilling for extended periods of time.

VARIABLE SPEED SWITCH

The variable speed switch delivers higher speed with increased trigger pressure and lower speed with decreased trigger pressure.

ASSEMBLY

UNPACKING

This product has been shipped completely assembled.

- Carefully remove the tool and any accessories from the box. Make sure that all items listed in the packing list are included.
- Inspect the tool carefully to make sure no breakage or damage occurred during shipping.
- Do not discard the packing material until you have carefully inspected and satisfactorily operated the tool.
- If any parts are damaged or missing, please call 1-800-932-3188 for assistance.

PACKING LIST

1/2 in. Drill
Case
Operator's Manual

 **WARNING:** If any parts are missing do not operate this tool until the missing parts are replaced. Failure to do so could result in possible serious personal injury.

 **WARNING:** Do not attempt to modify this tool or create accessories not recommended for use with this tool. Any such alteration or modification is misuse and could result in a hazardous condition leading to possible serious personal injury.

 **WARNING:** Do not connect to power supply until assembly is complete. Failure to comply could result in accidental starting and possible serious injury.

OPERATION

 **WARNING:** Do not allow familiarity with tools to make you careless. Remember that a careless fraction of a second is sufficient to inflict serious injury.

 **WARNING:** Always wear safety goggles or safety glasses with side shields when operating power tools. Failure to do so could result in objects being thrown into your eyes resulting in possible serious injury.

APPLICATIONS

You may use this tool for the purposes listed below:

- Drilling in wood
- Drilling in ceramics, plastics, fiberglass, and laminates
- Drilling in metals
- Mixing paint

OPERATION

VARIABLE SPEED SWITCH

See Figure 2.

To turn the drill **ON**, depress the variable speed switch. To turn it **OFF**, release the switch.

VARIABLE SPEED

See Figure 2.

The variable speed switch delivers higher speed and torque with increased trigger pressure and lower speed with decreased trigger pressure.

NOTE: You might hear a whistling or ringing noise from the switch during use. Do not be concerned; this is a normal part of the switch function.

FORWARD/REVERSE

See Figure 2.

The direction of bit rotation is reversible and is controlled by a selector located above the variable speed switch. With the drill held in normal operating position, the direction of rotation selector should be positioned to the left of the switch for drilling. The drilling direction is reversed when the selector is to the right of the switch.

CAUTION: To prevent gear damage, always allow the chuck to come to a complete stop before changing the direction of rotation.

To stop the drill, release the switch and allow the chuck to come to a complete stop.

NOTE: The drill will not run unless the direction of rotation selector is pushed fully to the left or right.

Avoid running the drill at low speeds for extended periods of time. Running at low speeds under constant usage may cause the drill to become overheated. If this occurs, cool the drill by running it without a load and at full speed.

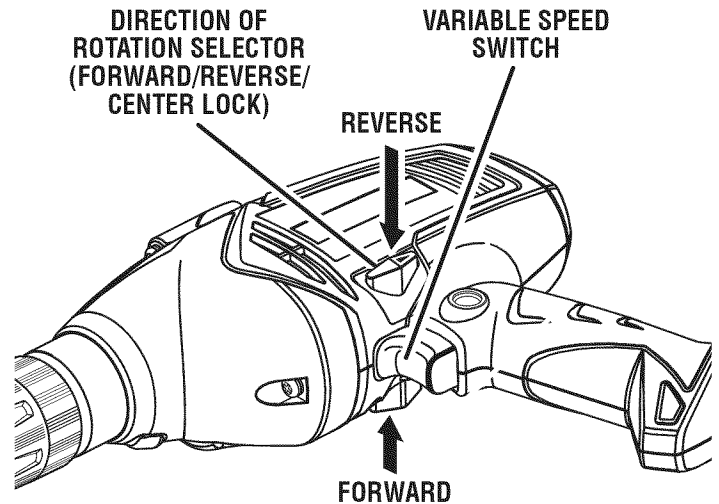

Fig. 2

KEYLESS CHUCK

See Figure 3.

The drill has a keyless chuck that makes it simple to tighten or release drill bits in the chuck jaws. Grasp and hold the collar of the chuck with one hand. Rotate the chuck body with your other hand. The arrows on the chuck indicate which direction to rotate the chuck body in order to **LOCK** (tighten) or **UNLOCK** (release) the drill bit.

WARNING: Do not hold the chuck body with one hand and use the power of the drill to tighten the chuck jaws on the drill bit. The chuck body could slip in your hand, or your hand could slip and come in contact with the rotating drill bit. This could cause an accident resulting in serious personal injury.

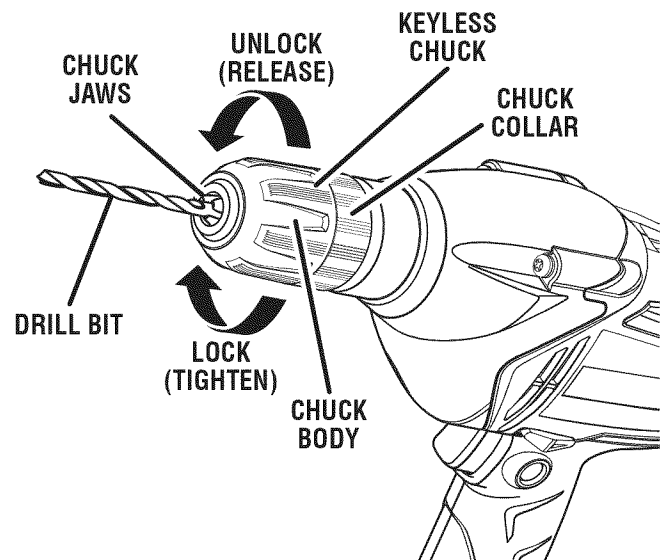

Fig. 3

OPERATION

WARNING: Always unplug the tool when installing or removing bits, adjusting settings, or when the tool is not in use. Failure to unplug the tool may result in accidental starting and serious personal injury.

INSTALLING BITS

See Figures 4 - 5.

- Unplug the drill.
- Open or close the chuck jaws to a point where the opening is slightly larger than the bit size you intend to use. Also, raise the front of the drill slightly to keep the bit from falling out of the chuck jaws.
- Insert the drill bit.

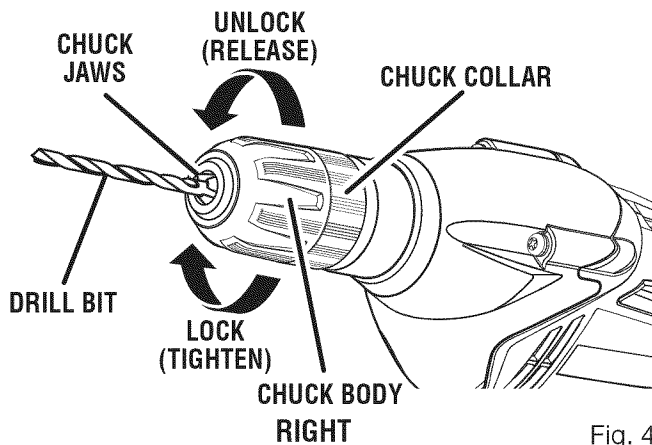

Fig. 4

WARNING: Make sure to insert the drill bit straight into the chuck jaws. Do not insert the drill bit into the chuck jaws at an angle then tighten, as shown in figure 5. This could cause the drill bit to be thrown from the drill, resulting in possible serious personal injury or damage to the chuck.

- Rotate the chuck clockwise to tighten the chuck jaws securely on the bit.

NOTE: Rotate the chuck body in the direction of the arrow marked **LOCK** to tighten the chuck jaws. Do not use a wrench to tighten or loosen the chuck jaws.

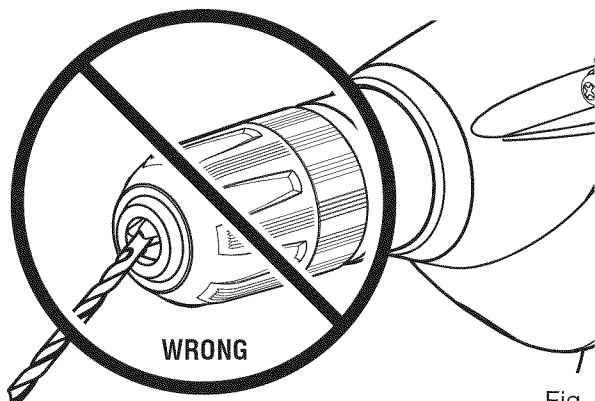

Fig. 5

REMOVING BITS

See Figure 4.

- Unplug the drill.
- Rotate the chuck sleeve clockwise to open the chuck jaws.

NOTE: Rotate the chuck body in the direction of the arrow marked **UNLOCK** to loosen the chuck jaws. Do not use a wrench to tighten or loosen the chuck jaws.

- Remove the drill bit.

USING THE AUXILIARY HANDLE ASSEMBLY

See Figure 6.

An auxiliary handle is packed with the drill for ease of operation and to help prevent loss of control. The handle can be rotated 360° and it can also be mounted on the opposite side for left hand use.

To adjust the auxiliary handle assembly:

- Loosen the handle assembly by turning the handle counterclockwise.
- Rotate the auxiliary handle assembly to the desired operating position.
- Securely tighten by turning the auxiliary handle clockwise.

NOTE: For convenience and ease of starting threads, the hex nut has been trapped inside the molded slot in the auxiliary handle.

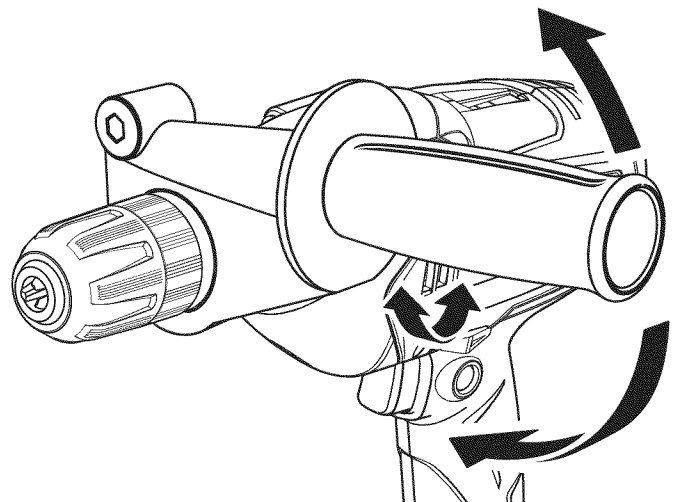

Fig. 6

OPERATION

LOCK-ON BUTTON

See Figure 7.

This drill is equipped with a lock-on feature, which is convenient for continuous drilling for extended periods of time. To lock-on:

- Depress the variable speed switch.
- Push in and hold the lock-on button, located on the side of the handle.
- Release the variable speed switch.
- Release the lock-on button and the drill will continue running.
- To release the lock, depress and release the variable speed switch.

If the lock-on feature is engaged during use and the drill becomes disconnected from the power supply, disengage the lock-on feature immediately.

⚠ WARNING: Before connecting the drill to a power supply source, always check to be sure it is not in lock-on position (depress and release the variable speed switch). Failure to ensure that it is not locked-on could result in accidental starting of the drill resulting in possible serious injury. Do not lock the variable speed switch in applications where the drill may need to be suddenly stopped.

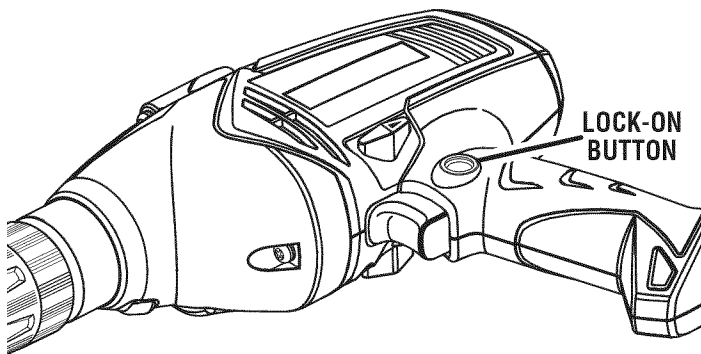

Fig. 7

DRILLING

See Figures 8 - 9.

Levels are located on the top and end of the motor housing to help keep the drill bit level during use.

- Depress and release the variable speed switch to be sure the drill is in the **OFF** position before connecting it to a power supply.
- Check the direction of rotation selector for the correct setting (forward or reverse).
- Secure the material to be drilled in a vise or with clamps to keep it from turning as the drill bit rotates.
- Plug the drill into power supply. Hold the drill firmly and place the bit at the point to be drilled.
- Depress the variable speed switch to start the drill.
- Move the drill bit into the workpiece, applying only enough pressure to keep the bit cutting. Do not force the drill or apply side pressure to elongate a hole. Let the tool do the work.

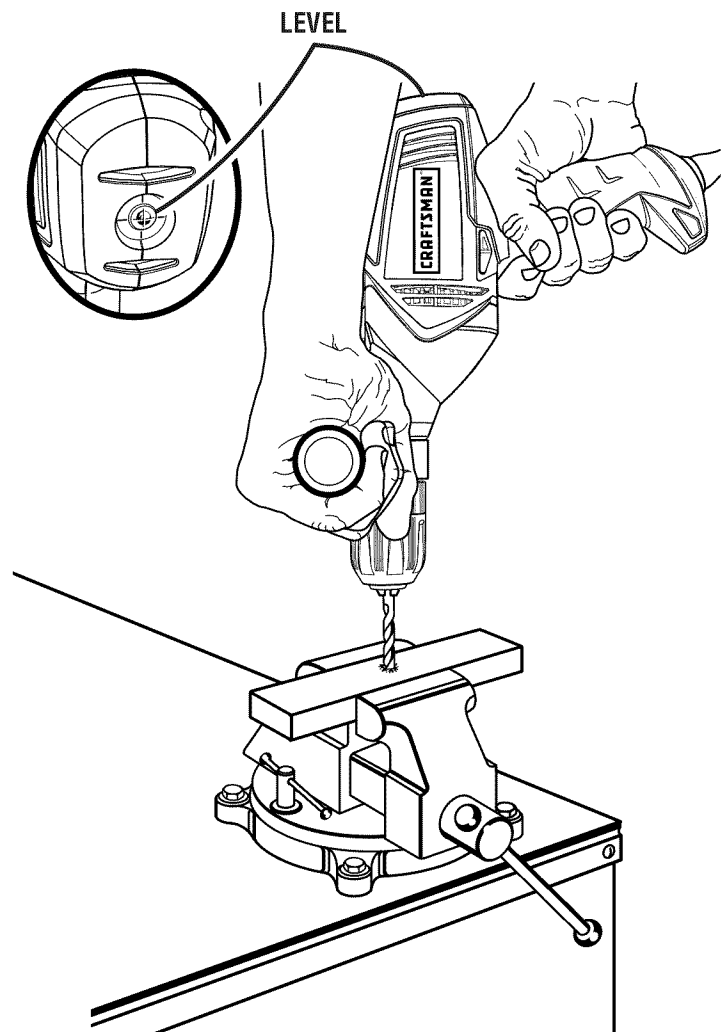

Fig. 8

OPERATION

⚠ WARNING: Be prepared for binding at bit breakthrough. When these situations occur, the drill has a tendency to grab and kick in the opposite direction and could cause loss of control when breaking through material. If not prepared, this loss of control can result in possible serious injury.

- When drilling hard, smooth surfaces, use a center punch to mark the desired hole location. This will prevent the drill bit from slipping off-center as the hole is started.
- When drilling metals, use a light oil on the drill bit to keep it from overheating. The oil will prolong the life of the bit and increase the drilling action.
- If the bit jams in the workpiece or if the drill stalls, stop the tool immediately. Remove the bit from the workpiece and determine the reason for jamming.

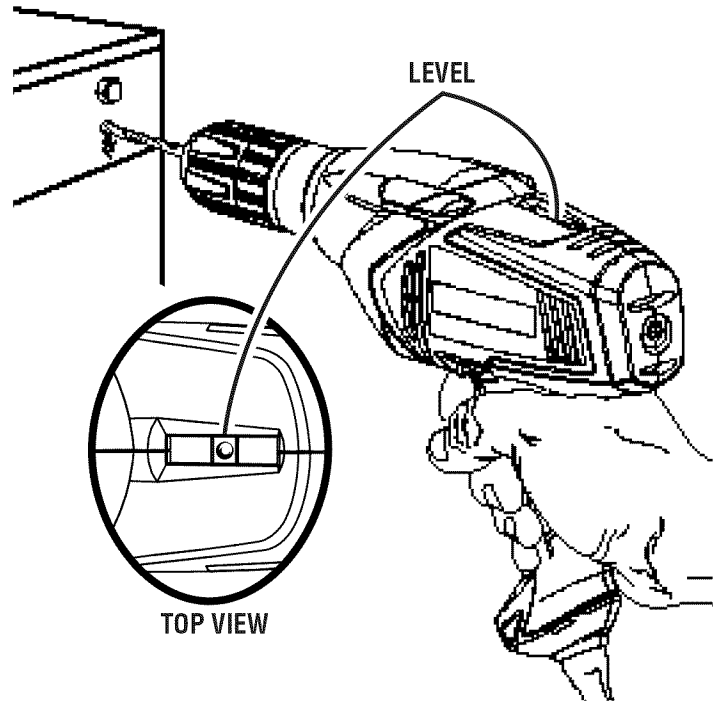

Fig. 9

MAINTENANCE

⚠ WARNING: When servicing, use only identical Craftsman replacement parts. Use of any other parts may create a hazard or cause product damage.

⚠ WARNING: Always wear safety goggles or safety glasses with side shields during power tool operation or when blowing dust. If operation is dusty, also wear a dust mask.

GENERAL MAINTENANCE

Avoid using solvents when cleaning plastic parts. Most plastics are susceptible to damage from various types of commercial solvents and may be damaged by their use. Use clean cloths to remove dirt, dust, oil, grease, etc.

⚠ WARNING: Do not at any time let brake fluids, gasoline, petroleum-based products, penetrating oils, etc., come in contact with plastic parts. Chemicals can damage, weaken or destroy plastic which may result in serious personal injury.

Electric tools used on fiberglass material, wallboard, spackling compounds, or plaster are subject to accelerated wear and possible premature failure because the fiberglass chips and grindings are highly abrasive to bearings, brushes, commutators, etc. Consequently, we do not recommend using this tool for extended work on these types of materials. However, if you do work with any of these materials, it is extremely important to clean the tool using compressed air.

LUBRICATION

All of the bearings in this tool are lubricated with a sufficient amount of high grade lubricant for the life of the unit under normal operating conditions. Therefore, no further lubrication is required.

Only the parts shown on the parts list are intended to be repaired or replaced by the customer. All other parts should be replaced at a Sears Service Center.

CHUCK REMOVAL

See Figures 10 - 12.

The chuck may be removed and replaced with a new one.

- Unplug the drill.
- Insert a 5/16 in. or larger hex key into the chuck of the drill and tighten the chuck jaws securely.
- Tap the hex key sharply with a mallet in a clockwise direction. This will loosen the screw in the chuck for easy removal.

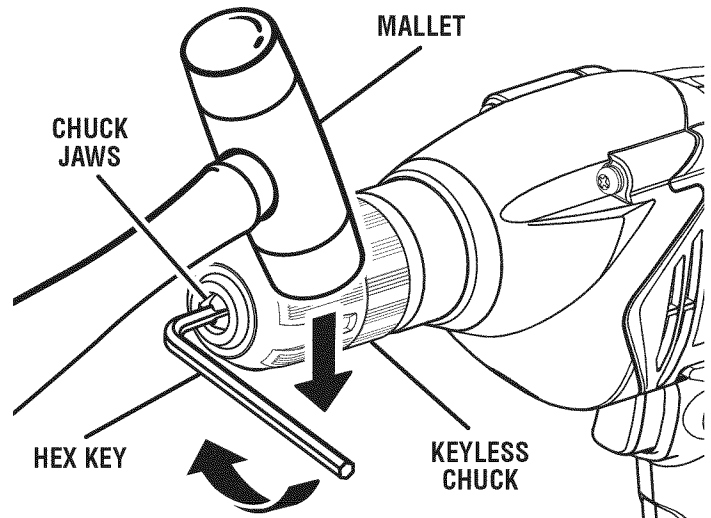

Fig. 10

- Open the chuck jaws and remove the hex key. Using a screwdriver, remove the chuck screw by turning it in a clockwise direction.

NOTE: The chuck screw has left hand threads.

- Insert the hex key into the chuck and tighten the chuck jaws securely. Tap sharply with a mallet in a counter-clockwise direction. This will loosen the chuck on the spindle. It can now be unscrewed by hand.

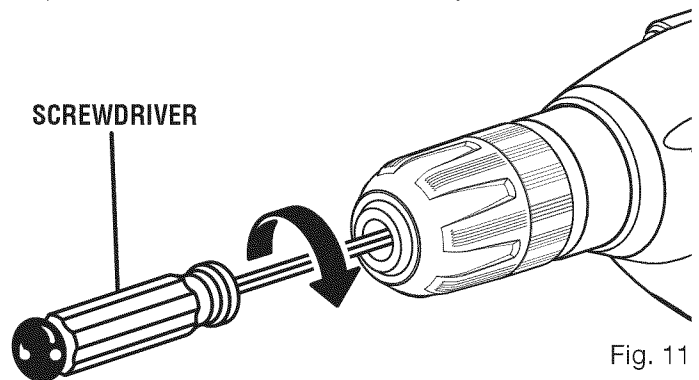

Fig. 11

MAINTENANCE

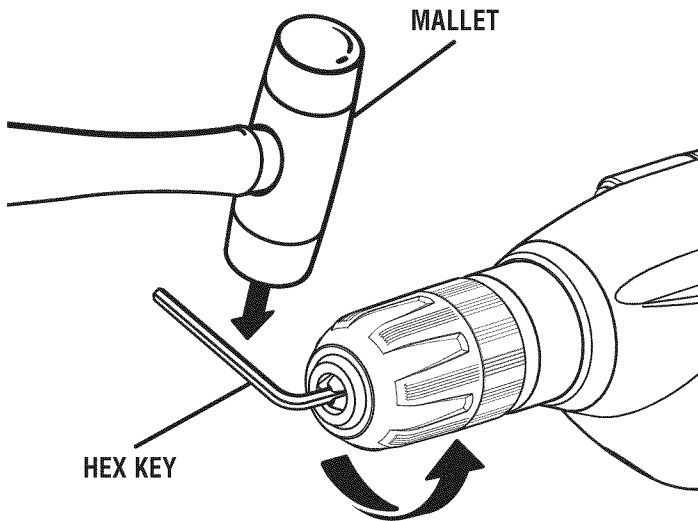

Fig. 12

TO RETIGHTEN A LOOSE CHUCK

The chuck may become loose on the spindle and develop a wobble. Also, the chuck screw may become loose, causing the chuck jaws to bind and prevent them from closing. To tighten:

- Unplug the drill.
- Open the chuck jaws.
- Insert a hex key into the chuck and tighten chuck jaws securely. Tap the hex key sharply with a mallet in a clockwise direction. This will tighten the chuck on the spindle.
- Open the chuck jaws and remove the hex key.
- Tighten the chuck screw.

ACCESSORIES

Look for these accessories at Sears retail:

- High Speed Bits (For wood or metal) 1/2 in. Max.
- Masonry Bits 3/4 in. Max.
- Wood Boring Bits 1-1/4 in. Max.
- Hole Saws 2 in. Max.

⚠ WARNING: Current attachments and accessories available for use with this tool are listed above. Do not use any attachments or accessories not recommended by the manufacturer of this tool. The use of attachments or accessories not recommended can result in serious personal injury.

CRAFTSMAN 1/2 in. DRILL MODEL NUMBER 315.101150

The model number will be found on a plate attached to the motor housing. Always mention the model number in all correspondence regarding your **DRILL** or when ordering repair parts.

SEE BACK PAGE FOR PARTS ORDERING INSTRUCTIONS

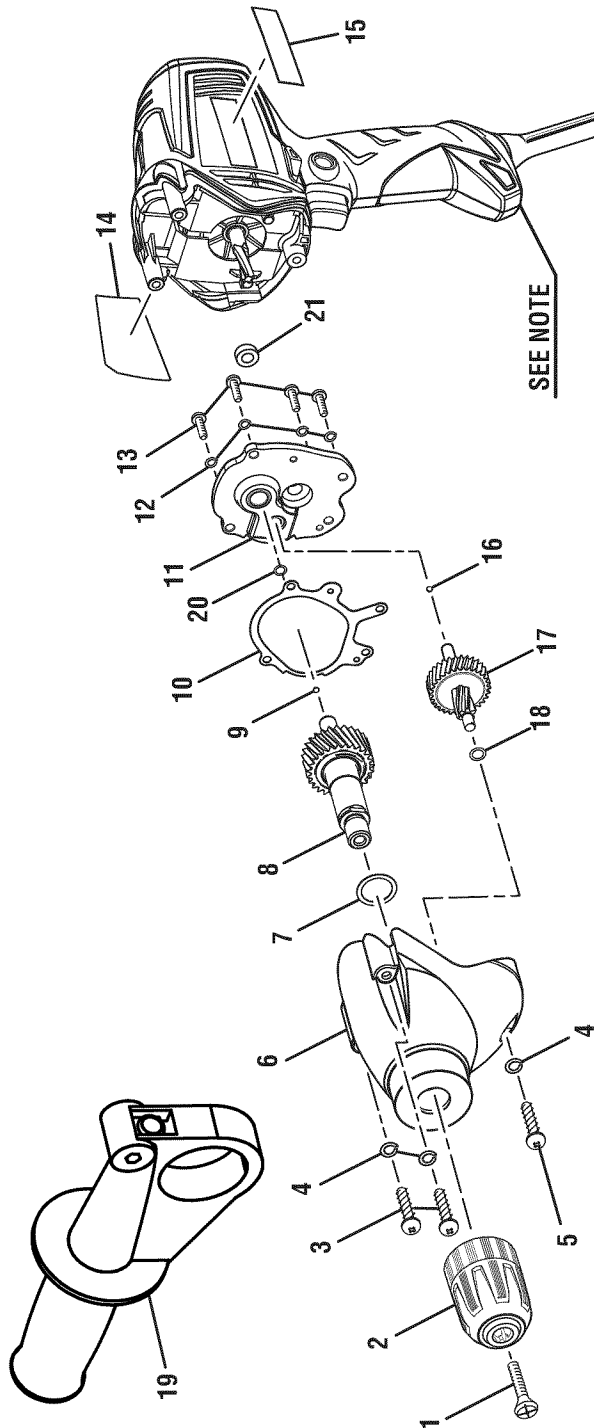

PARTS LIST

Key No.	Part Number	Description	Qty.	Key No.	Part Number	Description	Qty.
1	6613402	Screw (Special)	1	12	6703001	Spring Washer	4
2	690033056	1/2 in. Chuck	1	13	6616503	* Screw (M4 x 18 mm Pan Hd.)	4
3	660299014	* Screw (M5 x 21 mm Pan Hd.)	2	14	940301041	Data Label	1
4	6796001	* Spring Washer (M5)	3	15	940114123	Logo Label	1
5	660299004	* Screw (M5 x 18 mm Pan Hd.)	1	16	6722101	Steel Ball (3 mm Dia.)	1
6	200269003	Gear Housing Assembly	1	17	3067502	Intermediate Gear and Pinion Assembly	1
7	690426002	Washer	1	18	6309201	Washer	1
8	300676005	Output Gear Assembly	1	19	300188058	Auxiliary Handle Assembly	1
9	6721901	Steel Ball (5 mm)	1	20	6929501	Thrust Washer (OD8.0 x 0.5 mm)	1
10	901092001	Oil Seal	1	21	671498001	Ball Bearing (608 2RS)	1
11	200294003	Bearing Plate with Bearings	1		300912231	Carrying Case (Not Shown)	1
					983000741	Operator's Manual (960223580)	1

NOTE: The assembly shown represents an important part of the Double Insulated System. To avoid the possibility of alteration or damage to the system, service should be performed by your nearest Sears Repair Center. Contact your nearest Sears Retail Store for Service Center information.

* Standard Hardware Item - May Be Purchased Locally