

48" Professional Grill



BGB48-BQAR 48" Grill with Rotisserie and optional cart
BGB48-BQR 48" Grill with Rotisserie and Integrated Sealed Side Burners (as shown)

The ultimate in outdoor cooking. This fully featured grill delivers professional performance and delicious results. Precision ported, U-shaped 304 grade stainless steel burners rated at 25,000 BTU's per burner offer powerful performance and control. The patented Smart Beam® grill light perfects grilling at night with a 50-watt halogen light integrated into the patented rotisserie motor that is capable of illuminating the entire grilling surface. Our patented Grease Management System® reduces flare-ups by effectively channeling oil and grease away from the flame while grilling. A 9-volt Battery Ignition ensures safe and efficient grill lighting every time and Double-Sided Cast 304 Grade Stainless Steel Grilling Grates feature one side with a gentle radius for support and handling while the other side is W-shaped for maximum grease capture while leaving perfect sear lines. Ceramic Radiant Technology provides intense, even heat. The Dedicated Infrared Rotisserie Burner supplies controllable searing heat. The heavy-duty Rotisserie Motor with Stainless Steel Rod and Forks can accommodate up to 50 pounds. Patented design features of the grill are complemented by the DCS original styled cart with robust side shelf supports, drop-in serving trays, and large storage drawers.

ADDITIONAL FEATURES:

- Smoker tray with dedicated 3,500-BTU burner
- Removable stainless steel warming rack
- Optional integrated sealed side burners
- Available for built-in or on cart applications
- Designer metal control knobs
- Removable stainless steel drip tray

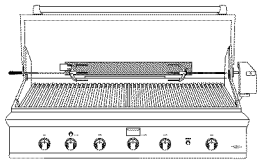

BGB48-BQAR

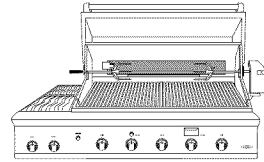

BGB48-BQR

48" Grill Dimensions (with optional grill cart)

Grill Model: BGB48-BQAR
Cart Model: CAD-48

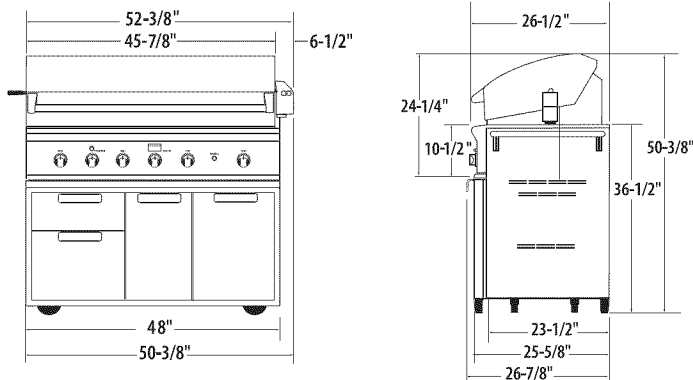

48" Grill Dimensions (with optional grill cart)

Grill Model: BGB48-BQR
Cart Model: CAD-48

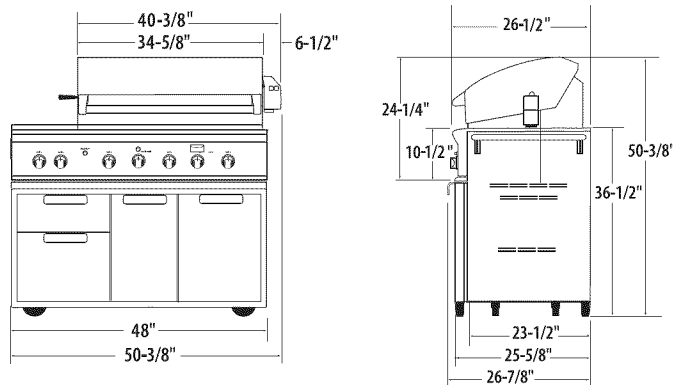

MODEL NUMBER	BGB48-BQAR	BGB48-BQR
TOTAL COOKING AREA	1167 SQ. INCHES	1123 SQ. INCHES
PRIMARY COOKING AREA (GRILL AREA)	840 SQ. INCHES	638 SQ. INCHES
SECONDARY COOKING AREA (WARMING RACK)	327 SQ. INCHES	241 SQ. INCHES
TWO SIDE BURNERS		244 SQ. INCHES
GRILL BURNERS	4 @ 25,000 BTU/HR	3 @ 25,000 BTU/HR
INTEGRATED SIDE BURNERS		2 @ 17,000 BTU/HR
INTEGRATED ROTISSERIE BURNER	18,000 BTU/HR	14,000 BTU/HR
SMOKER BURNER	3,500 BTU/HR	3,500 BTU/HR
DOUBLE-SIDED GRILL GRATES	304 GRADE STAINLESS STEEL	304 GRADE STAINLESS STEEL
GREASE MANAGEMENT SYSTEM*	✓	✓
SHIPPING WEIGHT (GRILL HEAD)	365 LBS.	345 LBS.
SHIPPING WEIGHT (OPTIONAL CART)	190 LBS.	190 LBS.
SHIPPING DIMENSIONS (HEIGHT X WIDTH X DEPTH)	32" X 52" X 31-1/2"	32" X 52" X 31-1/2"

48" Grill Island Preparation

Grill Models: BGB48-BQAR/BGB48-BQR

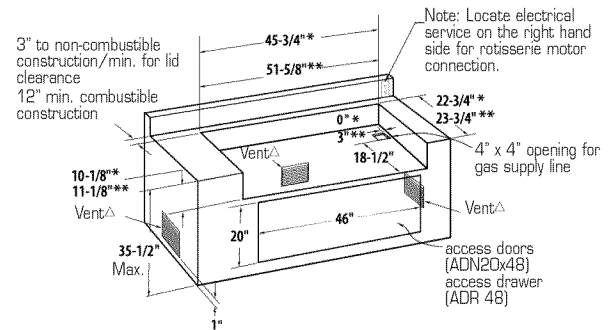

* Standard cut-out dimensions for non-combustible enclosure
** Insulated jacket cut-out dimensions for combustible enclosure
△ Island installation to use minimum of 3 vents providing 10 square inches per vent (typical)

Ordering Data:

Please specify gas type (natural or propane) when ordering

Gas Requirements:

Natural

- 1/2" NPT male with a 3/8" flare adapter
- Operational Pressure: 4" W.C.
- Supply Pressure: 6" to 9" W.C.

Propane

- 1/2" NPT male with a 3/8" flare adapter
- LP hose with a quick disconnect & fitting are shipped connected
- Operational Pressure: 10" W.C.
- Supply Pressure: 11" to 14" W.C.

Power Requirements:

- 120V 60Hz for models with Rotisserie Motor.

Island Ventilation Requirements:

It is recommended that adequate ventilation holes must be provided in the base of an enclosure in the event of a gas leak.

Grill Placement:

DO NOT build grill under overhead unprotected combustible construction. Use only in well-ventilated areas. These units are for outdoor use only. If located in a consistently windy area (oceanfront, mountaintop, etc.) a wind break will be required.

Conversion Kits:

NG to LP and LP to NG conversion kits are available from your dealer.

Accessories

- Stainless Steel Grill Cart (CAD-48)
- Single or double side burners for built-in application
- Stainless Steel Access Doors for built-in application
- Stainless Steel Access Drawers for built-in application
- Insulated Jacket for built-in application
- Grilling Tool Set
- Brazilian Cherry Chopping Board that fits in cart side-shelf
- Drop-on Griddle Plate
- Vinyl Grill Cover
- Wok and Wok Ring for use on side burners

We encourage you to find out more about these features and learn how they can make your cooking experience more enjoyable by visiting our learning page at: www.dcsappliances.com.

Because of continuing product improvement these specifications are subject to change without notice.