

## Use & Care Guide

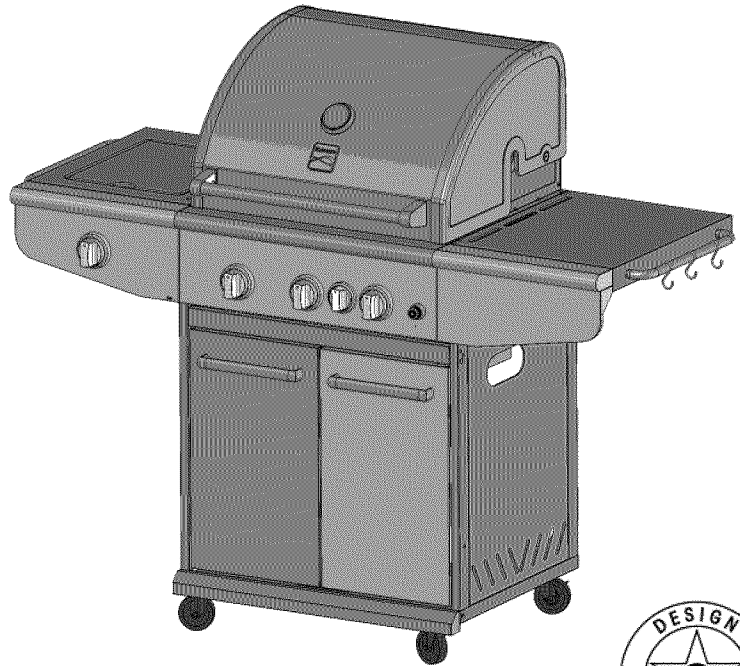



### Liquid Propane Gas Grill Sears Model No: 119.16433010

- Safety
- Parts
- Use and Care
- Assembly
- Español, Pg. 30



### This Grill is for Outdoor Use Only

	<b>WARNING</b>	
<ul style="list-style-type: none"><li>• Read and follow all Safety, Assembly, and Use &amp; Care Instructions in this Guide before assembling and cooking with this grill.</li><li>• Failure to follow all instructions in this Use &amp; Care Guide may lead to fire or explosion, which could result in property damage, personal injury or death.</li></ul>		

### Grill Information Center

Missing Parts? Assembly Questions?  
Operation Problems? Before  
returning grill to store,  
call **1-800-933-0527**

### Tools needed for assembly:

Protective work gloves and eyewear  
Phillips head screwdriver (included  
in hardware pack)

## SAVE THESE INSTRUCTIONS!

See our extensive assortment of outdoor living products on-line at  
[www.sears.com](http://www.sears.com) and [www.kmart.com](http://www.kmart.com)

Sears Brands Management Corporation, Hoffman Estates, IL 60179 U.S.A.

## Table of Contents

Primary Safety Warnings.....	1-3
Warranty Information.....	2
Pre-Assembly Instructions.....	3
Part Diagram and Lists.....	4-7
Assembly Instructions.....	8-18
Use & Care Instructions.....	19-27
Frequently Asked Questions.....	28-29
Spanish Guide.....	30-58
Repair Protection Agreement.....	59
Sears Parts and Service Information .....	60

## Warranty

### Kenmore Full Warranty

If this grill fails due to a defect in material or workmanship within one year from the date of purchase, call 1-800-4-MY-HOME® to arrange for

free repair (or replacement if repair proves impossible).

For five years from the date of purchase, the stainless steel burners will be replaced free of charge if they rust through. After the first year from the date of purchase, you must pay the labor cost to have them installed.

All warranty coverage excludes ignitor batteries, grill part paint loss, discoloration, and surface rusting, which are either expendable parts that can wear out from normal use within the warranty period, or are conditions that can be the result of normal use, accident or improper maintenance.

All warranty coverage is void if this grill is ever used for commercial or rental purposes.

All warranty coverage applies only if this grill is used in the United States.

This warranty gives you specific legal rights, and you may have other rights which vary from state to state.

**Sears, Roebuck and Co., Hoffman Estates, IL 60179**

## CAUTION

For residential use only. Do not use for commercial cooking.



## DANGER



### IF YOU SMELL GAS:

- **Shut off gas to the appliance.**
- **Extinguish any open flame.**
- **Open lid.**
- **If odor continues, keep away from the appliance and immediately call your gas supplier or your fire department.**



## WARNING



- **Do not store or use gasoline or other flammable liquids or vapors in the vicinity of this or any other appliance.**
- **An LP cylinder not connected for use shall not be stored in the vicinity of this or any other appliance.**

## Grill Information Center

If you are missing parts, need assistance during assembly, or have any other questions, please call 1-800-933-0527 between the hours of 8:30am and 5:00pm, Monday through Friday, Central time.

Note that you will be speaking with a representative of the grill manufacturer and not a Sears employee.

Product Record

**IMPORTANT:** Fill out the product record information on below.

- **Model Number** 119.16433010
- **Serial Number** \_\_\_\_\_  
(See silver CSA plate inside of left door)
- **Date Purchased** \_\_\_\_\_



## WARNING



California Proposition 65

1. Combustion by-products produced when using this product contain chemicals known to the State of California to cause cancer, birth defects, and other reproductive harm.
2. This product contains chemicals, including lead and lead compounds, known to the State of California to cause cancer, birth defects or other reproductive harm.

## Safety Information



### WARNING



- DO NOT light this grill without first reading the Lighting Instructions.
- DO NOT light this grill without checking the burner tubes for blockage that could have occurred during shipment. See the Cleaning and Maintenance Instructions.



### WARNING



- DO NOT use any type of charcoal in this grill.
- DO NOT operate the main burners and back burner at the same time. (If Equipped)
- ALWAYS inspect the grease tray before each use. Remove and clean as necessary.



### WARNING



This outdoor cooking gas appliance is not intended to be installed in or on boats or recreational vehicles.



### WARNING



Liquid Propane Gas (LPG) grills must be used with the liquid propane gas regulator assembly supplied. This grill is not convertible to natural gas. ALWAYS keep the gas hose assembly away from any heated surface and dripping grease. Avoid unnecessary twisting of the hose. Visually inspect the hose prior to each use for cuts, cracks, excessive wear, or other damage. Do not use the gas grill if the hose appears damaged. Call Sears at 1-800-4-MY-HOME® (1-800-469-4663) for a Kenmore replacement gas hose assembly.

## Grill Installation Codes

The installation must conform with local codes or, in the absence of local codes, with either the National Fuel Gas Code, ANSI Z223.1/NFPA 54, or CAN/CGA B149.1, Natural Gas and Propane Installation Code, or Propane Storage and Handling Code, B149.2.

## Electrical Grounding

All electrical accessories (such as a rotisserie or light) must be electrically grounded in accordance with local codes, or in the absence of local codes, with the National Electrical Code, ANSI/NFPA 70, or the Canadian Electrical Code, CSA C22.1. Keep any electrical cords away from hot surfaces.

## General Safety

- NEVER use your gas grill in a building, garage, porch, shed, breezeway or any other enclosed area.
- NEVER obstruct the flow of ventilation air around your gas grill cabinet.
- DO NOT leave children and pets unattended in the area when the grill is in operation.
- ENSURE the grill is on a level surface when in operation. You can adjust the feet in front to level and stabilize the grill.
- NEVER attach an unregulated gas line to this appliance.

## PRE-ASSEMBLY

- Two people will be necessary to assemble the larger parts of the grill.
- Lay a cardboard sheet on the floor and use as a work surface to protect floor and grill parts from scratches.
- Once all parts are removed and unpacked, use the Hardware and Part Diagrams to ensure all items are included and free of damage.

## Hardware Pack Diagram

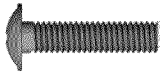

A

Phillips Head Bolt M6x35mm  
Qty: 4 pcs

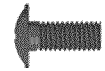

B

Phillips Head Bolt M6x16mm  
Qty: 24 pcs



C

Phillips Head Bolt M6x10mm  
Qty: 4 pcs



D

Phillips Head Bolt M4x8mm  
Qty: 22 pcs



E

Plastic Washer M6  
Qty: 8 pcs

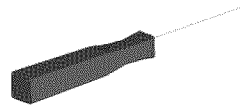

F

Phillips Head Screwdriver  
Qty: 1 pc



G

Battery Size AA  
Qty: 1 pc

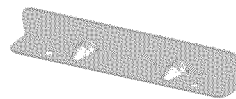

H

Cabinet Door Stop  
Qty: 1 pc



I

"S" Hook  
Qty: 3 pcs



J

Washer M4  
Qty: 4 pcs

## Parts List 119.16433010

Key	Qty	Part No.	Description
A1	1	*ASMA0085-01	Hood Assembly
A2	2	*ASMA0014-03	Hood Bolt Assembly
A3	1	CA0046-001	Hood Handle Seat Assebmly
A4	2	FLPP0114	Hood Handle Heat Insulator
A5	1	SE0213	Thermometer
A6	1	CA0045-002	Thermometer Seat
A7	1	*ASMA0014-05	Hood Handle
B1	1	*ASMB0085-01	Firebox Assembly
B2	1	SC1020	Gas Manifold Assembly
B3	1	*ASMB0085-02	Firebox Front Heat Shield
B4	1	SD0051	Rotisserie Burner
B5	1	*ASMB0085-03	Rotisserie Burner Orifice Support
B6	1	SC0097	Rotisserie Burner Orifice
B7	1	S1027-037D-006	Rotisserie Burner Cover
B8	3	SD0024-A	Main Burner
B9	3	SE9009	Main Burner Electrode
B10	1	S1018-000C-026	Grease Tray
B11	3	PLABS0090-001	Control Knob - Large
B12	1	PLABS0103-001	Control Knob - Small
B13	1	PLABS0104-001	Control Knob Seat - Small
B14	3	FA0121-001	Control Knob Seat - Large
B15	1	SE0286-012	Warming Rack
B16	1	SE0287-013	Grease Pan Bracket
B17	1	S1020-023D-004	Grease Pan
B18	1	*ASMB0085-04	Electronic Igniter Wire Set
B19	1	SB0131B	Electronic Igniter Button
B20	1	SE0078	Electronic Igniter
B21	1	*ASMB0085-05	Main Burner Control Panel top Panel
B22	1	*ASMB0085-06	Main Burner Control Panel
B23	3	S1007-012E-016	Heat Diffuser
B24	1	SC0101	Side Burner Valve
B25	1	SE0148	Regulator and Hose Assembly
B26	2	CI0018-012	Cooking Grate
B27	1	SC0100	Rotisserie Burner Flame Sensor
B28	1	SE0237Z	Rotisserie Burner Electrode
B29	1	*ASMB0085-07	Rotisserie Burner Electrode Protection Box
B30	1	SH1100-A	Rotisserie Burner Stem
B31	1	S1046-000C-001	Rotisserie Burner Electrode Support
B32	4	FE0025M	Hood Bumper
C1	1	SE0153-002	Side Burner Cover Pin

## Parts List 119.16433010

Key	Qty	Part No.	Description
C2	1	S7004-042D-001	Side Burner Cover
C3	1	S7001-042D-017	Side Burner Outer Frame Assembly
C4	1	*ASMD0085-01	Side Burner
C5	1	*ASMD0085-02	Side Burner Upper Control Panel
C6	1	PLABS0090-001	Control Knob Seat- Large
C7	1	PLABS0103-001	Control Knob - Large
C8	1	S7005-F00B-026	Side Burner Lower Control Panel
C9	1	*ASMC0012-08	Towel Bar Handle
C10	1	SE0084-012	Side Burner Cooking Grate
C11	1	*ASMD0085-03	Side Burner Inner Frame
C12	1	SE0083	Side Burner Electrode
C13	2	SB0045-001	Side Burner Stopper
D1	1	S7002-042D-005	Side Shelf Assembly
D2	1	*ASMD0085-02	Side Shelf Upper Front Panel
D3	1	S7005-000B-027	Side Shelf Lower Front Panel
D4	1	*ASMC0012-08	Towel Bar Handle
D5	3	SE0123-002	"S" Hook
E1	1	*ASMC0085-01	Cabinet Assembly
E2	2	SE0257	Swivel Caster
E3	1	S4025-042D-002	Cabinet Door Stop
E4	2	SE0055	Swivel Locking Caster
E5	1	*ASMC0085-02	Cabinet Toe Plate
E6	1	SE0080-001	Regulator and Hose Support Ring
E7	1	SE0290-002	Cylinder Support Ring
E8	2	SE0150	Magnetic Door Stop
E9	1	*ASMC0085-03	Cabinet Front Crossbar
E10	1	SE9027-011	Condiment Basket
E11	1	*ASMC0085-04	Cabinet Left Door
E12	1	*ASMC0085-05	Cabinet Right Door
E13	2	PLABS0092N-001	Cabinet Door Handle
E14	1	*ASMC0085-06	Cabinet Back Panel
E15	1	SE0019-001	Manual Igniter Stick
E16	2	SE0289-001	Door Bottom Pin
E17	2	SE0288-001	Door Top Pin

## Not Pictured

N/A	1	ASMF085	Hardware Pack
N/A	1	RNA0103	Manual

If you are missing hardware or have damaged parts after unpacking grill, call 1-800-933-0527 for replacement. To order replacement parts after using grill, call 1-800-4-MY-HOME®.

# Parts Diagram 119.16433010

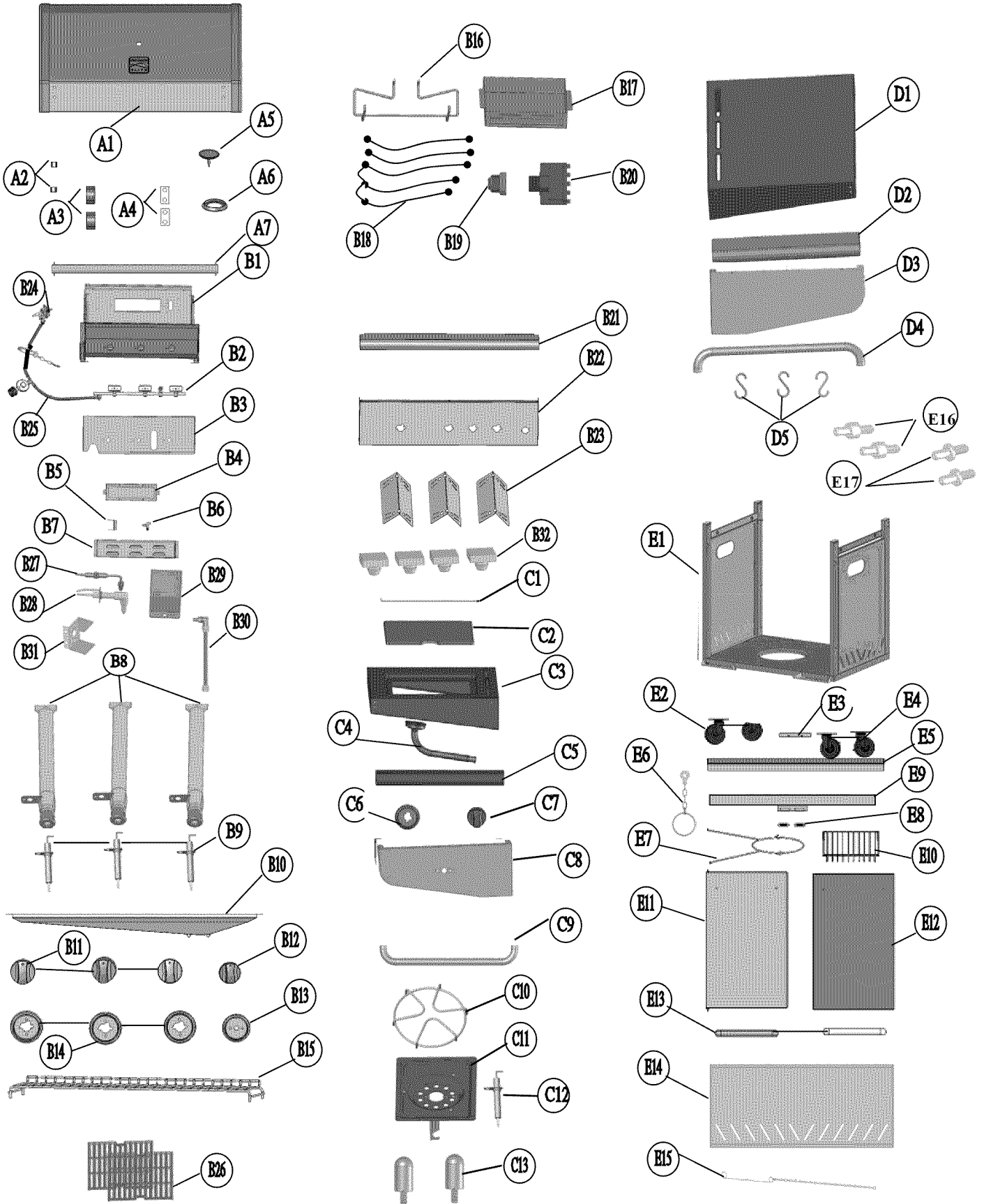

# Assembly Instruction

**1**

## Remove Firebox from Cabinet

- ❑ Cut fastening straps on Cabinet Toe Plate. Remove the Toe Plate and set aside. Cut fastening straps securing regulator and hose to cabinet.
- ❑ Unscrew and discard the 8 Phillips Head Bolts (M6x35mm) and 8 Washers (M6) from the corner holes of the cabinet. Remove the crossbar and set aside.
- ❑ With the aid of an assistant, carefully lift the cabinet up from the firebox and set aside. Remove all foam packing from the Firebox. Raise lid and remove and unpack parts inside Firebox.

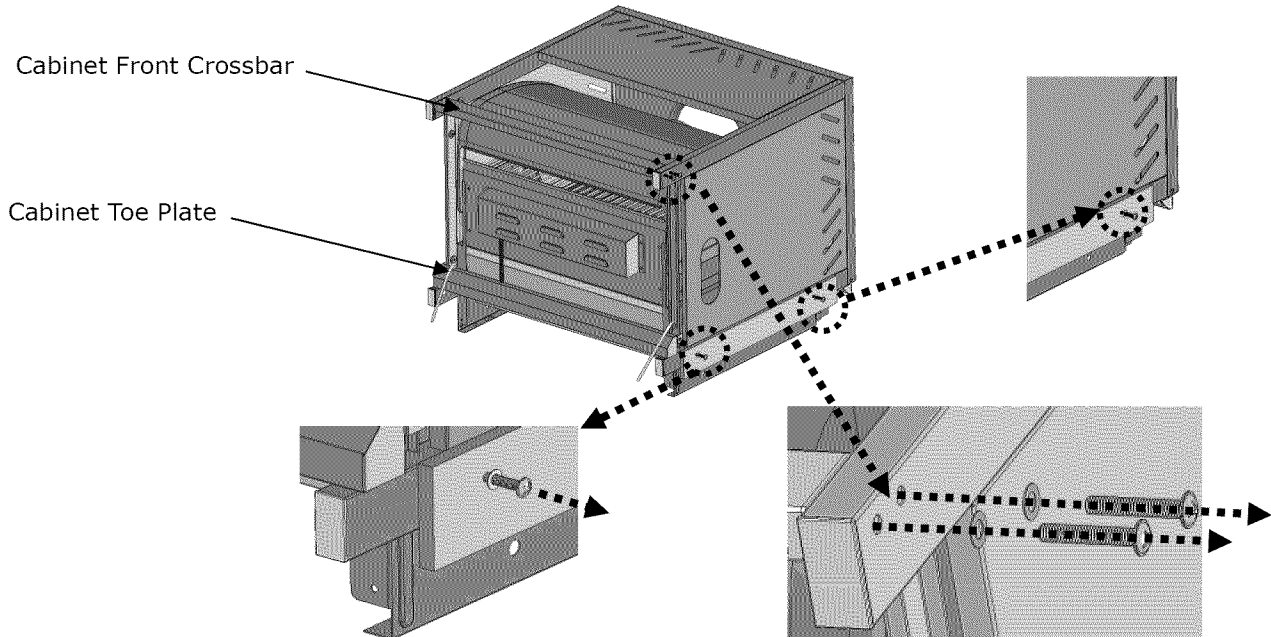

**2**

## Install Casters to Cabinet

- ❑ Place the Cabinet Assembly upside down and attach the 4 Casters to the bottom using 16 Phillips Head Bolts (M6x16mm). Install both locking casters on rear of cabinet.

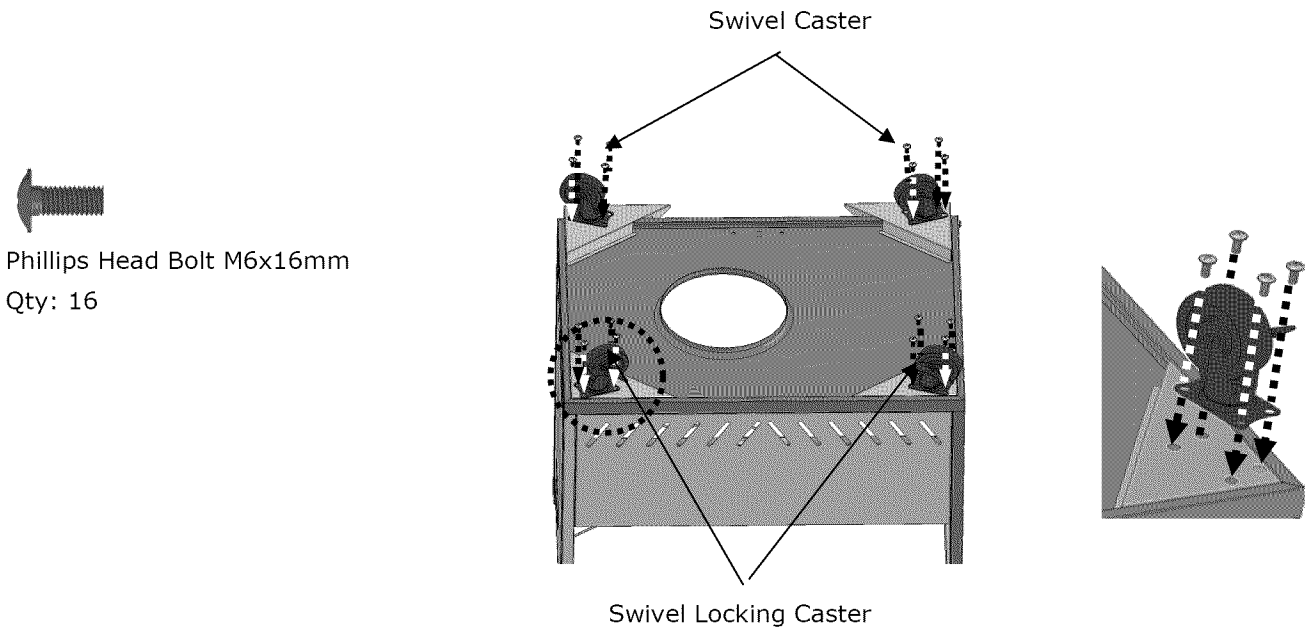



### 3

#### Install Cabinet Toe Plate

- Attach the Cabinet Toe Plate to the Cabinet Bottom Panel using 4 Phillips Head Bolts (M6x10mm).
- Place cabinet in upright position on casters.



Phillips Head Bolt M6x10mm  
Qty: 4

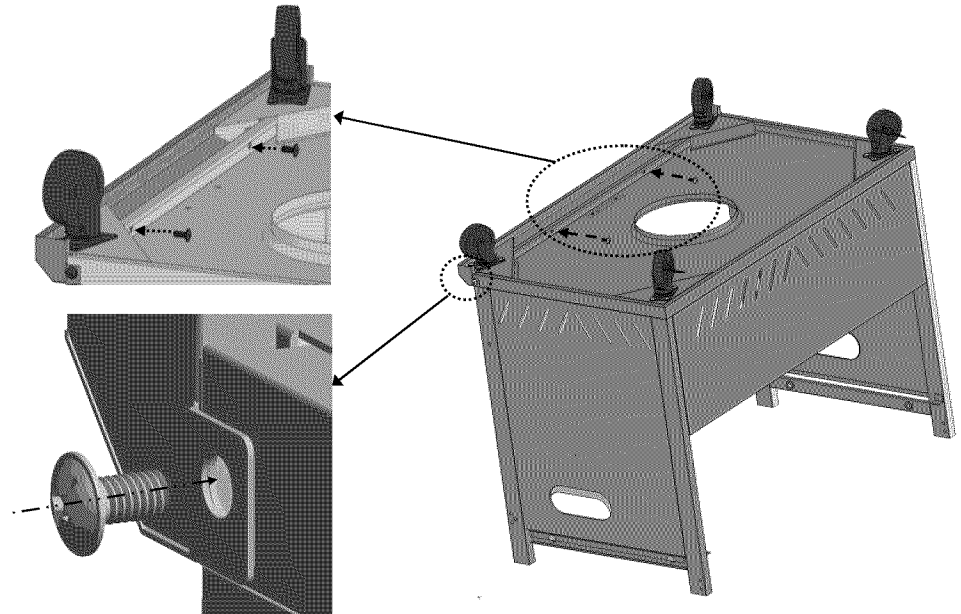

### 4

#### Install Cabinet Doors and Cabinet Front Crossbar

- Insert the Cabinet Right Door bottom pin into the Cabinet Bottom Panel (Inset 1), and insert the Cabinet Right Door top pin into the Cabinet Front Crossbar (Inset 2). With door magnets extending into Cabinet, attach the Cabinet Front Crossbar to the right side of the Cabinet using 2 Phillips Head Bolts (M6x35mm) and Plastic Washers (M6) (Inset 3). Do not fully tighten bolts at this time.
- Insert the Cabinet Left Door in the same way and attach Cabinet Front Crossbar to the left side of the Cabinet using 2 Phillips Head Bolts (M6x35mm) and Plastic Washers (M6). Fully tighten all 4 Front Crossbar bolts at this time.

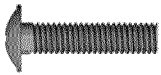

Phillips Head Bolts M6x35mm  
Qty: 4



Plastic Washer M6  
Qty: 4

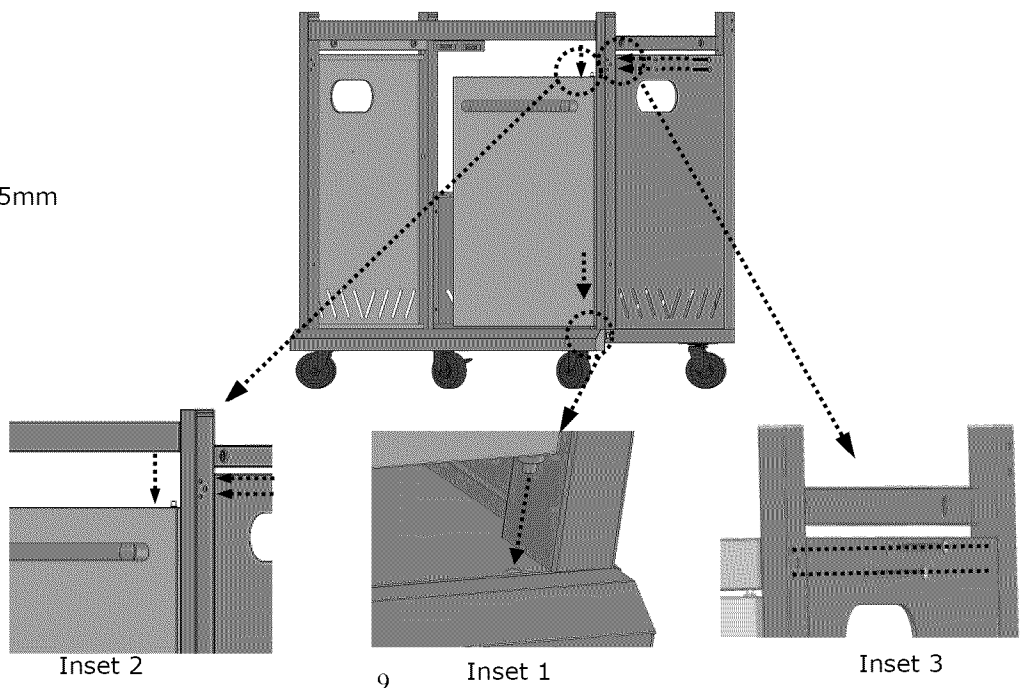

## 5

### Hang Condiment Basket and attach Cabinet Door Stop

- Attach the Cabinet Door Stop to the front of cabinet bottom using 2 Phillips Head Bolts (M4x8mm).
- Hang Condiment Basket on the inside of Cabinet Right Door.



Phillips Head Bolt M4x8mm  
Qty: 2

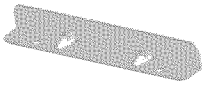

Cabinet Door Stop  
Qty: 1

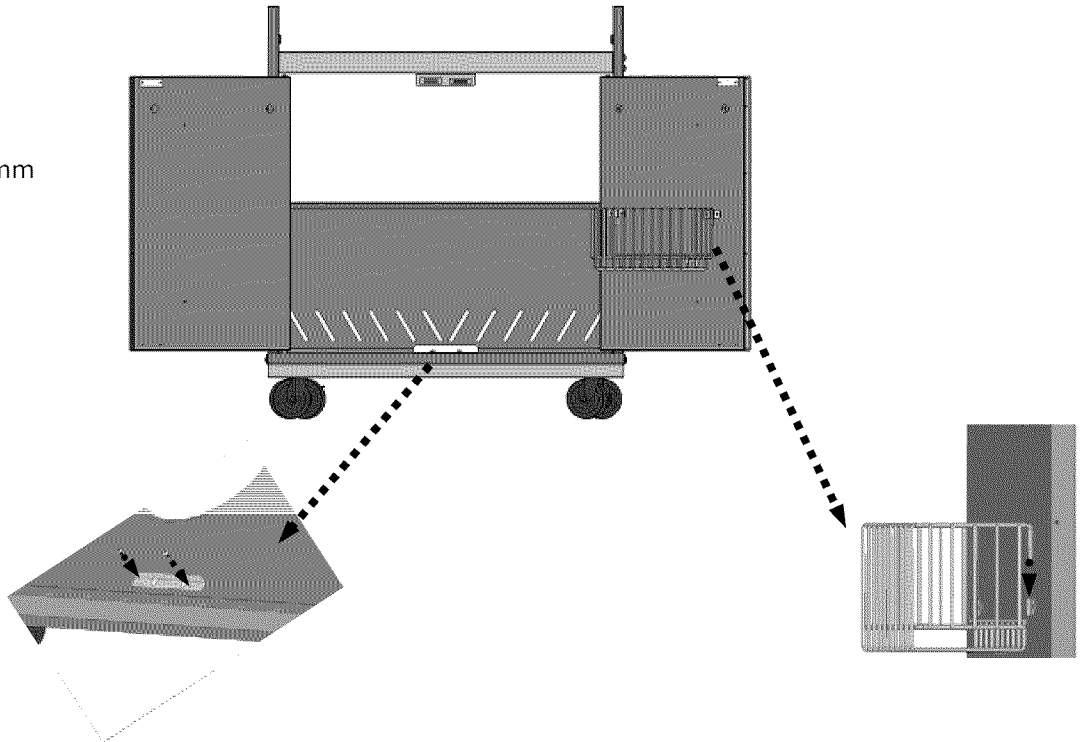

## 6

### Attach Firebox to Cabinet

- With the aid of an assistant, place the Firebox onto the Cabinet Frame with Regulator Hose and Side Burner Ignition Wire hanging inside of Cabinet. Note: Rear of Firebox rests on two tabs at back of Cabinet.
- Line up the holes and attach the firebox to the cabinet frame using 4 Phillips Head Bolts (M6x16mm) and 4 Plastic Washers (M6).  
Hint: You may need to slide the Firebox Assembly forward, backward, or lift slightly for the bolt holes to properly line up.
- Push the 3 Main Burner Control Knobs and smaller Rotisserie Control Knob onto Valve Stems as shown.

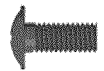

Phillips Head Bolt M6x16mm  
Qty: 4



Plastic Washer M6  
Qty: 4

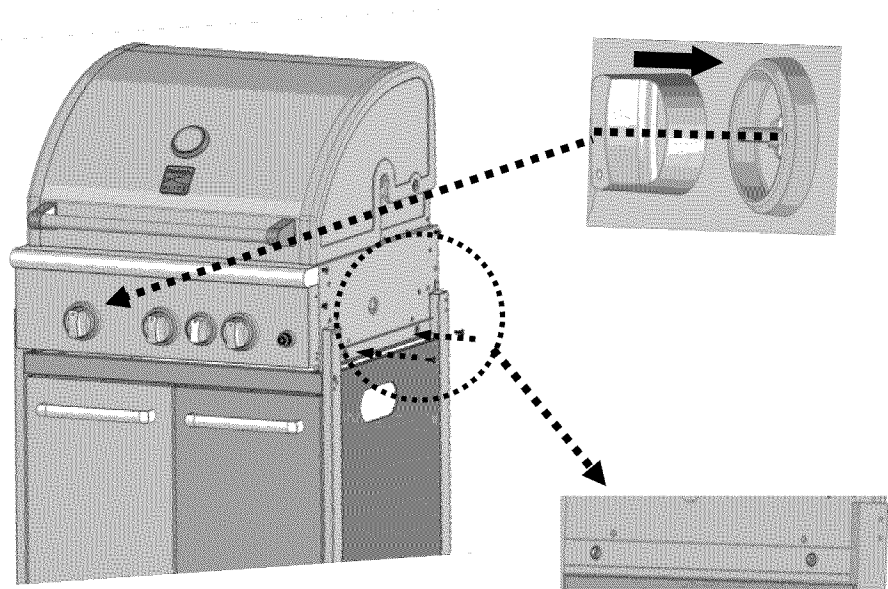

# 7

## Install Grease Tray

- Insert the Grease Tray along two sides of the Firebox from the back underneath the firebox. Insert tray with the grease drain hole positioned as shown. Be careful when sliding the tray past wires and fuel line. Slide tray fully in until it locks into place behind stops.

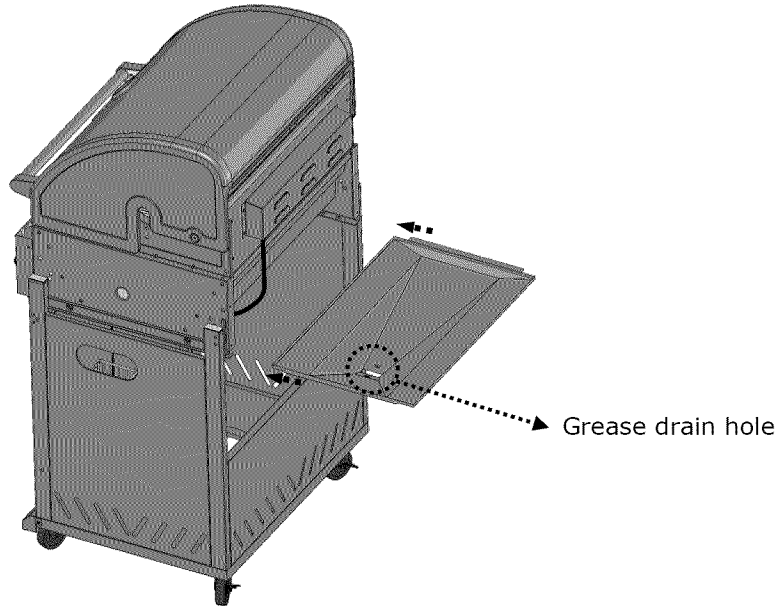

# 8

## Install Grease Pan Bracket and Grease Pan

- From the rear of cabinet, insert the Grease Pan Bracket into the bottom of the Grease Tray.
- From the front of Cabinet, insert the Grease Pan into the Grease Pan Bracket.

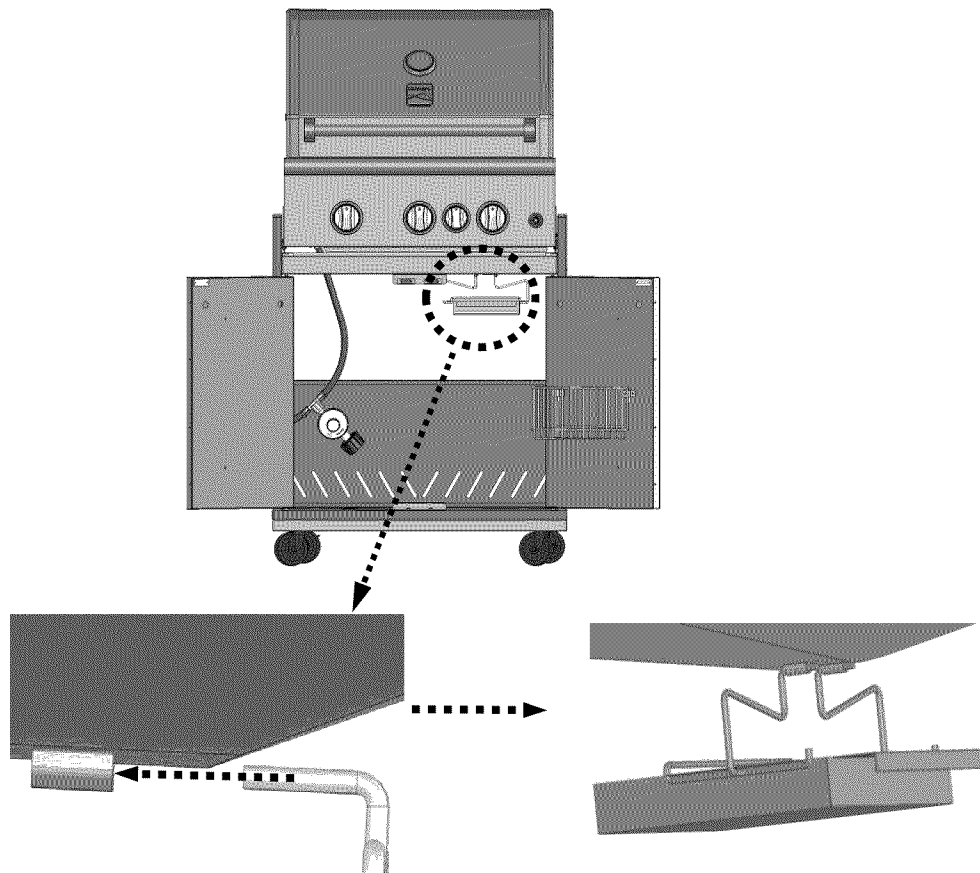

**9****Install Side Shelf Upper and Lower Front Panels**

- Attach the Side Shelf Upper Front Panel to Side Shelf Frame using 3 Phillips Head Bolts (M4x8mm).
- Attach the Side Shelf Lower Front Panel to Side Shelf Upper Front Panel using 3 Phillips Head Bolts (M4x8mm).

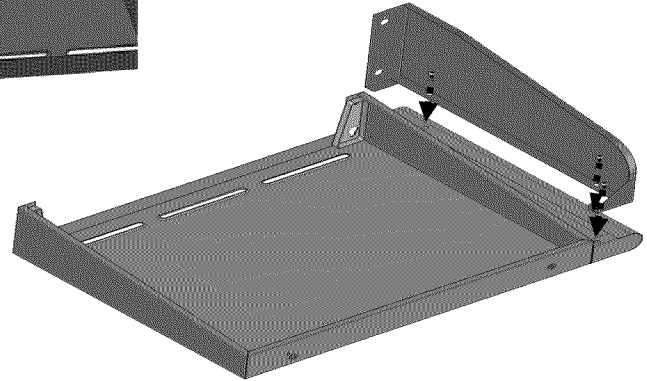
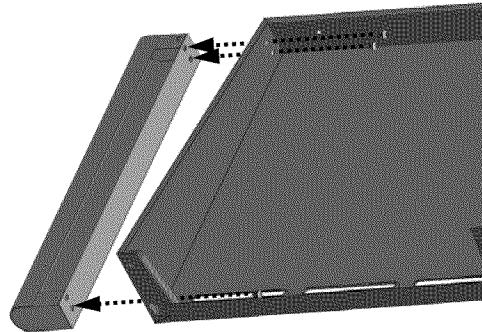

Phillips Head Bolt M4x8mm  
Qty: 6

**10****Install Towel Bar Handle, "S" Hooks**

- Slide 3 "S" Hooks onto the Towel Bar Handle. Use 2 Phillips Head Bolts (M4x8mm) and 2 Washers (M4) to attach the Towel Bar Handle to the Side Shelf Frame. Note: When shelf is in upright position, hooks should face out.



Phillips Head Bolt M4x8mm  
Qty: 2



Washer M4  
Qty: 2



"S" Hook  
Qty: 3

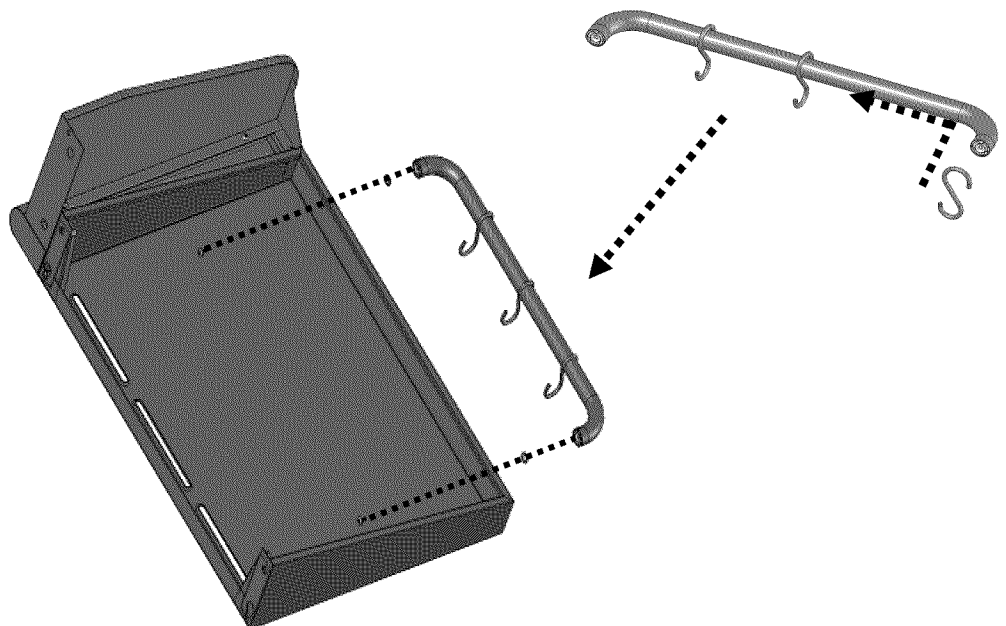

**11****Install Side Burner Upper and Lower Control Panels**

- Attach the Side Burner Upper Control Panel to Side Burner Frame using 3 Phillips Head Bolts (M4x8mm).
- Attach the Side Burner Lower Control Panel to Side Burner Frame using 3 Phillips Head Bolts (M4x8mm).



Phillips Head Bolt M4x8mm

Qty: 6

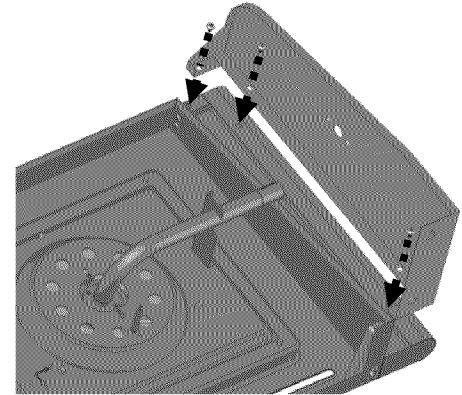
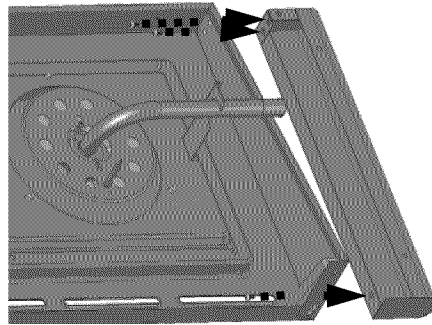
**12****Install Towel Bar Handle**

- Use 2 Phillips Head Bolts (M4x8mm) and 2 Washers (M4) to attach the second Towel Bar Handle to the Side Burner Frame.



Phillips Head Bolt M4x8mm

Qty: 2



Washer M4

Qty: 2

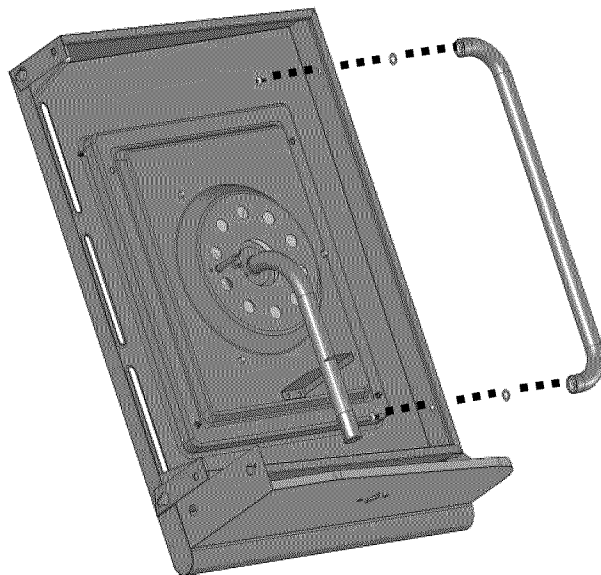

# 13

## Install Side Shelf Frame to Firebox

- ❑ Unscrew the 2 Phillips Head bolts ¼ inch from the upper left and right corner holes in the right side of the firebox as shown in Inset 1. The bolts extending out of the firebox sides are to attach the side shelf frame.
- ❑ Slide the upper holes of the side shelf frame over the heads of the 2 Phillips Head Bolts and drop down.
- ❑ Use 2 Phillips Head Bolts (M6x16mm) to attach the lower holes in the side shelf frame to the firebox as shown in Inset 2.
- ❑ Use 1 Phillips Head Bolt (M4x8mm) to attach the lower hole in the Side Shelf Control Panel to the firebox. See Inset 3.
- ❑ Tighten the 2 previously loosened Phillips Head bolts.

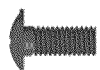

Phillips Head Bolt M6x16mm  
Qty: 2

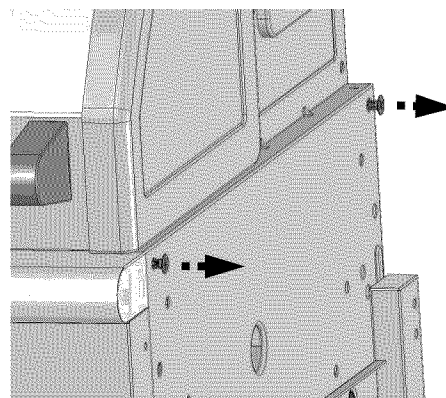

Inset 1

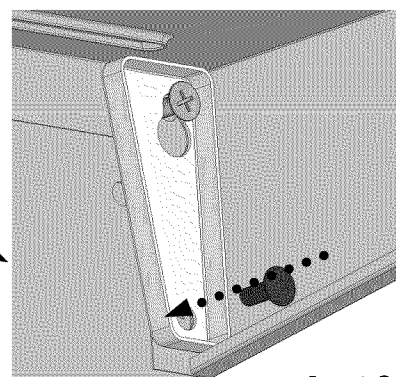
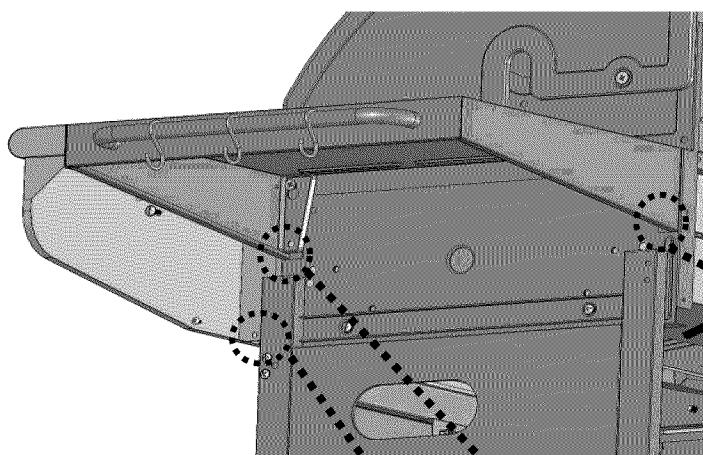

Inset 2



Phillips Head Bolt M4x8mm  
Qty: 1

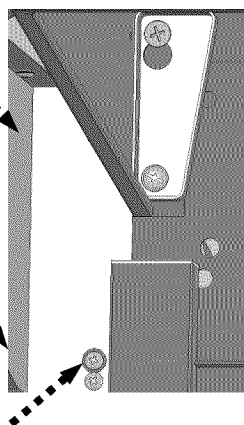

Inset 3

# 14

## Install Side Burner Frame to Firebox

- Unscrew the 2 Phillips Head bolts ¼ inch from the upper left and right corner holes in the left side of the firebox as shown in Inset 1. The bolts extending out of the firebox sides are to attach the side Burner frame.
- Slide the upper holes of the side Burner frame over the heads of the 2 Phillips Head Bolts and drop down.
- Use 2 Phillips Head Bolts (M6x16mm) to attach the lower holes in the side Burner frame to the firebox as shown in Inset 2.
- Tighten the 2 previously loosened Phillips Head bolts.



Phillips Head Bolt M6x16mm  
Qty: 2

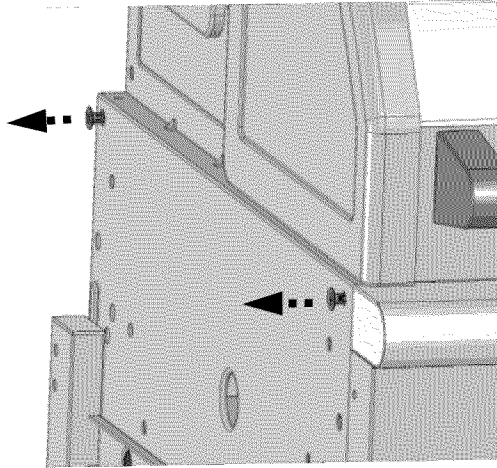

Inset 1

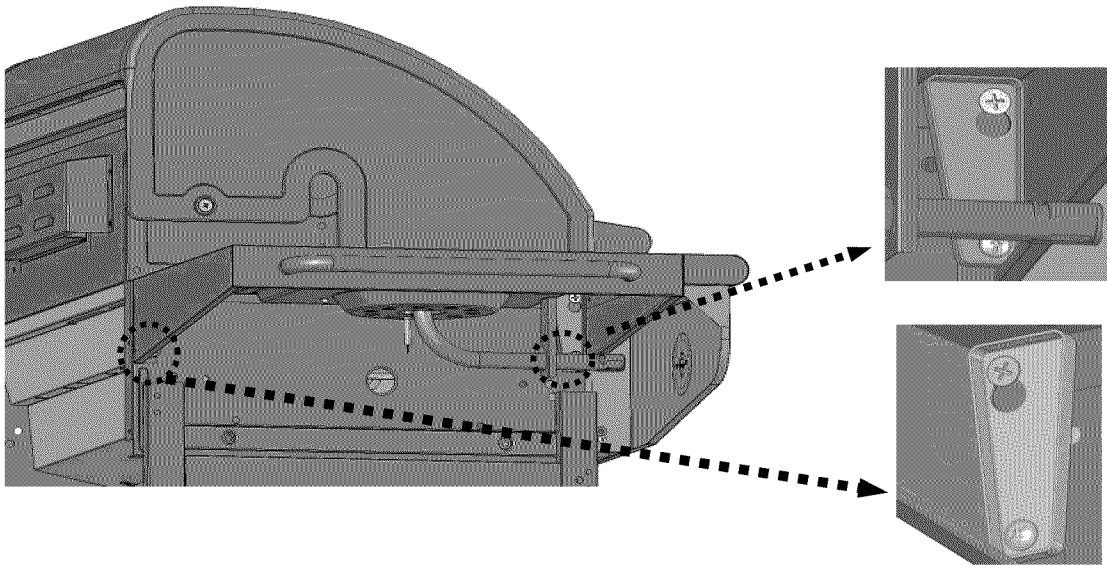

Inset 2

# 15

## Install Side Burner Valve

- Detach side burner ignition wire from the regulator hose. Feed side burner valve and igniter wire through hole in left side of cabinet.
- Open side burner lid and cut tie wrap securing grate to pan. On underside of pan, remove the 2 screws holding the side burner in place. See Inset 1.
- Secure the side burner valve stem to the Side Burner Lower Control Panel using 2 Phillips Head Bolts (M4x8mm). See Inset 2.
- Center the side burner valve into the side burner tube. See Inset 3. Reattach side burner to pan with 2 previously removed screws.
- Use 1 Phillips Head Bolt (M4x8mm) to attach the Side Burner Lower Control Panel to the firebox. See Inset 4.

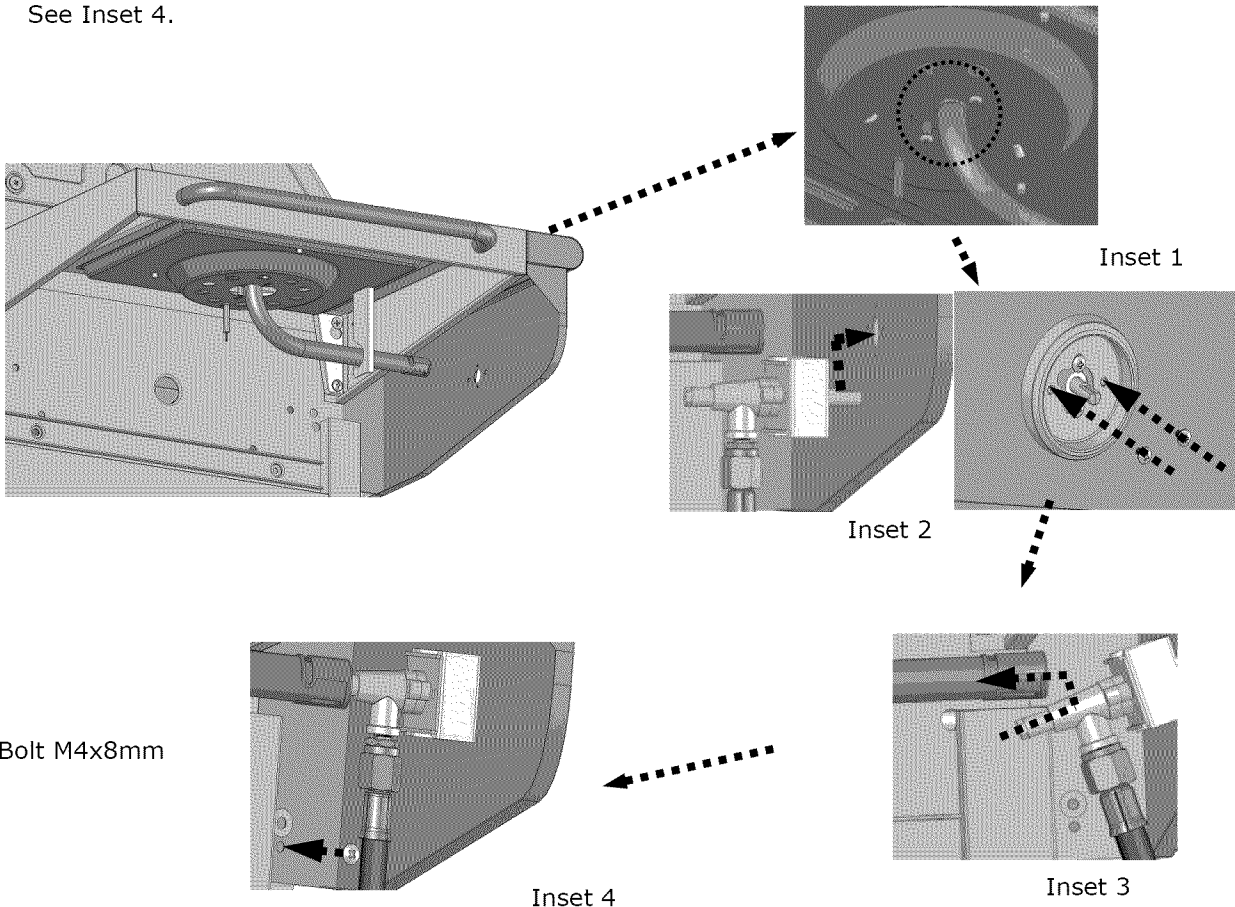

Phillips Head Bolt M4x8mm  
Qty: 3

# 16

## Attach Side Burner Control Knob and Side Burner Ignition Wire

- Attach the side burner ignition wire over the side burner connector pin.
- Push the Control Knob onto the valve stem.

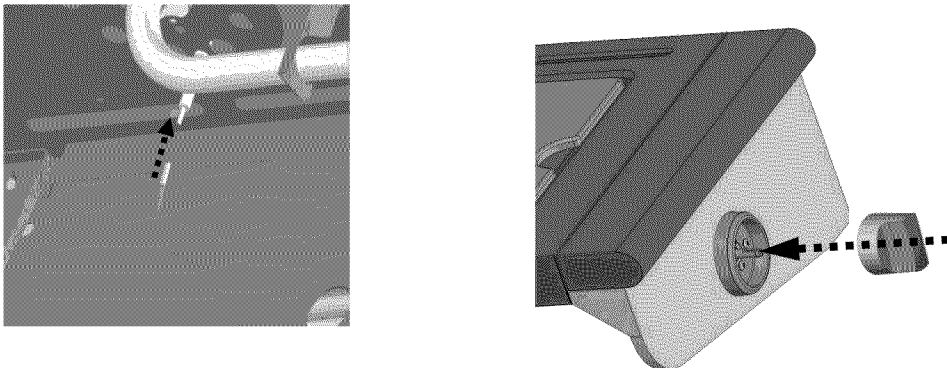



## 17

### Install Heat Diffusers, Cooking Grates, Warming Rack

- Insert the heat diffusers into the firebox by placing them into the indentations in the front and back of the firebox. See Inset 1.
- Place the Cooking Grates into the firebox. The grate bottoms have a small knob on each corner. See Inset 2.
- Insert the warming rack into the top of the firebox. See Inset 3. The raised lip goes towards the back of the firebox. See Inset 3.

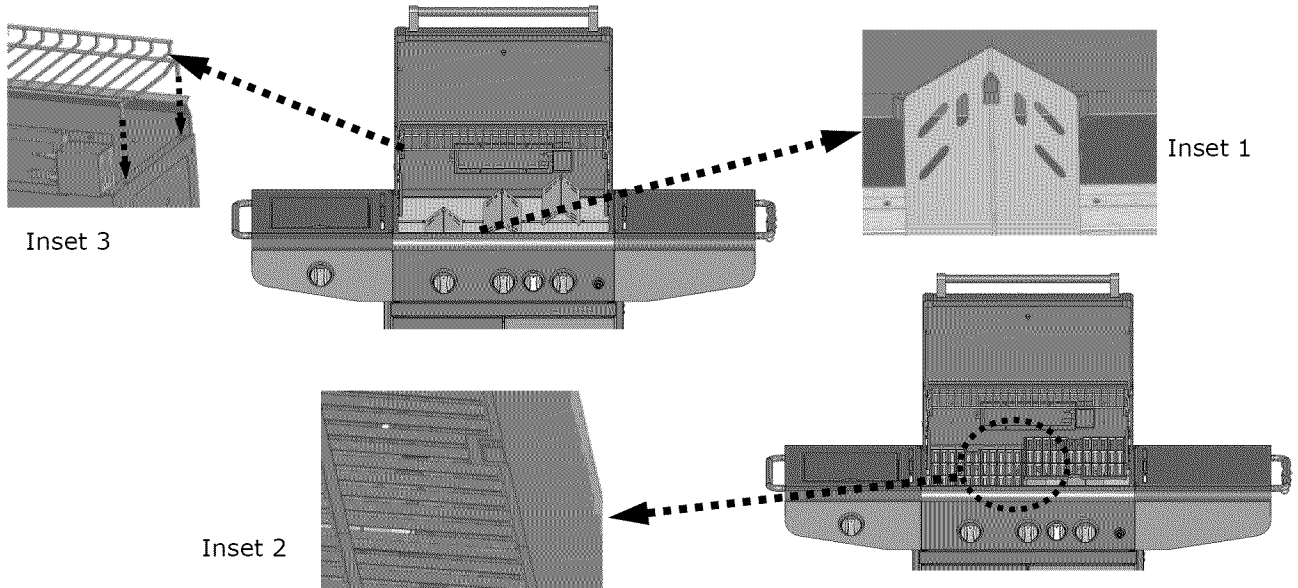

## 18

### Place and Secure LP Cylinder into the Cabinet

- Unscrew the bolt and nut located below the large opening in the left side cabinet panel. Attach the regulator hose support ring, located on the regulator hose, to the left side cabinet panel using the same bolt and nut. See Inset 1.
- Hook the ends of the Cylinder Support Ring into the two holes in the left front and rear legs. See Inset 2. Note: You may need to spread the ends apart for the ring to reach and securely fit into the holes.
- Place the LP cylinder down into the tank support hole in the bottom of the cabinet. Ensure the valve faces to the side. Wrap the Cylinder Support Ring around the top of the tank and hook together to secure the LP cylinder in place. See Inset 3.

**Do Not Hook Up the LP Cylinder to the Regulator Assembly at this time.**

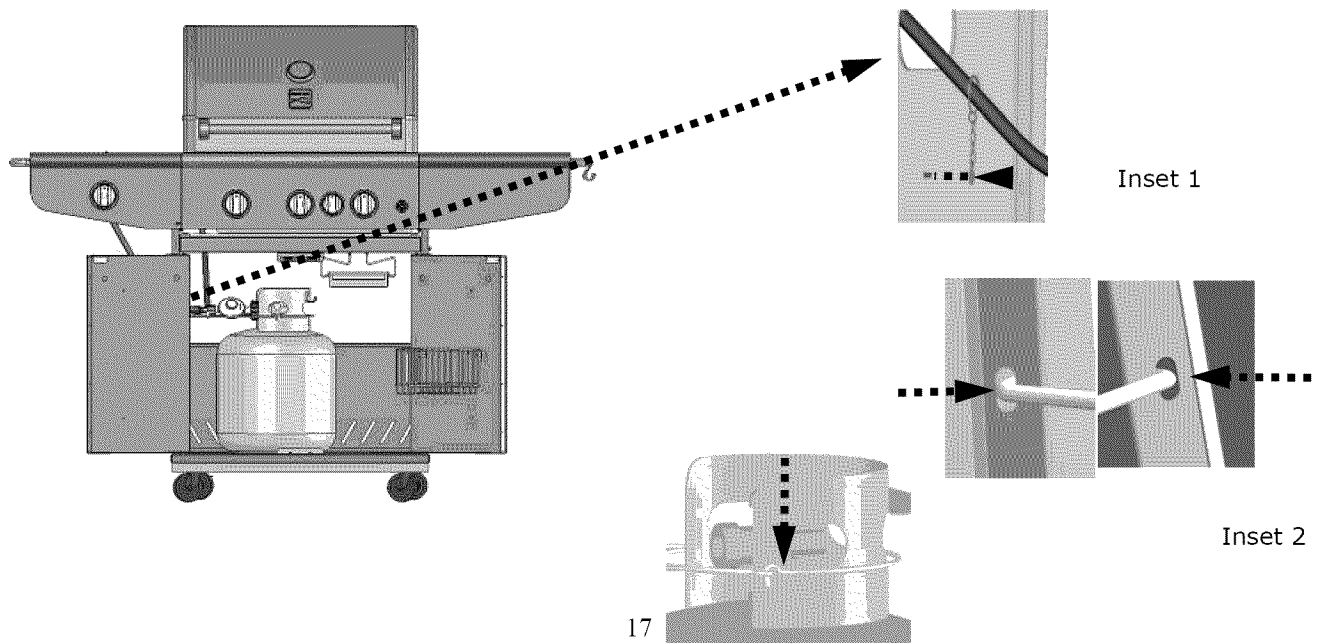

## 19

### Install Battery

- Unscrew the electronic ignition button. Place the AA Battery into the ignition with the positive (+) end facing out. Screw the electronic ignition button back into place.

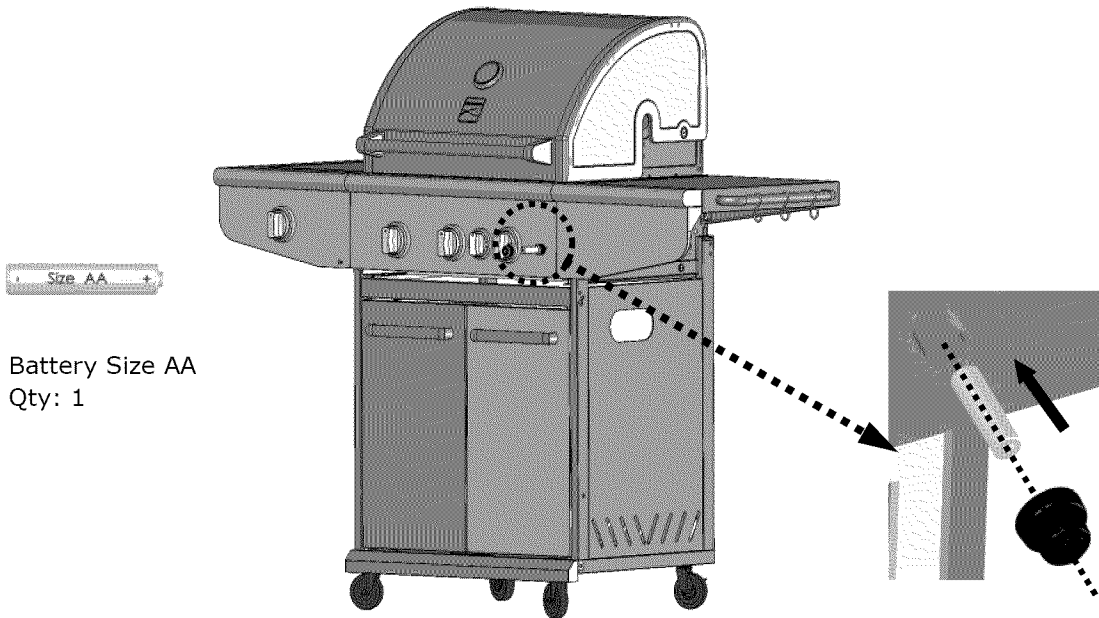

## 20

### Congratulations - Assembly is now complete!

- Remove any additional labels or packing material from the grill except the CSA label. Be sure to clean all foam packing material out of all areas.
- Read the remaining sections of the Use & Care Guide prior to operating your grill.
- To transport grill, grasp towel bar handle on the end of the side shelf for easier mobility, and make sure that the rear casters are unlocked (OFF side pushed down).

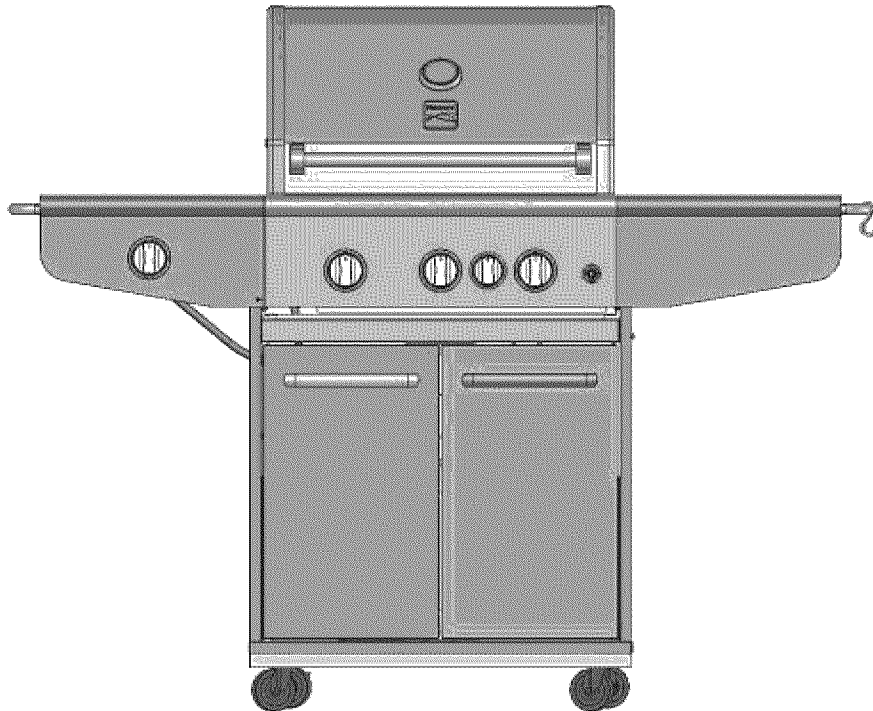



## LP Gas Tank Information

### CORRECT LP GAS TANK USE

- LP gas grill models are designed for use with a standard 20lb. (9.1kg) Liquid Propane Gas (LP Gas) tank, which is not included with the grill. Never connect your gas grill to an LP gas tank that exceeds this capacity. A tank of approximately 12" (305mm) in diameter by 18-1/2" (472mm) high is the maximum size LP gas tank to use. You must use an "OPD" gas tank which offers a listed Overfill Prevention Device. This safety feature prevents tanks from being overfilled which can cause malfunction of the LP gas tank, regulator and grill.
- The LP gas tank must be constructed and marked in accordance with the Specifications for LP-Gas Cylinders of the U.S. Department of Transportation (D.O. T.) or the National Standard of Canada, CAN/CSA-B339, Cylinders, Spheres and Tubes for Transportation of Dangerous Goods; and Commission, as applicable.
- The LP gas tank must have a shut off valve terminating in a LP gas supply tank valve outlet that is compatible with a Type 1 tank connection device. The LP gas tank must also have a safety relief device that has a direct connection with the vapor space of the tank.
- The tank supply system must have a means for vapor withdrawal.
- The LP gas tank used must have a collar to protect the tank valve.
- **Never** connect an unregulated LP gas tank to your gas grill. The gas regulator assembly supplied with your gas grill is adjusted to have an outlet pressure of 11"water column (W.C.) for connection to an LP gas tank. Only use the regulator and hose assembly supplied with your gas grill.  
**Replacement regulators and hose assemblies must be those specified by Sears.**  
See the Parts List.  
Have your LP Gas dealer check the release valve after every filling to ensure it remains free of defects. Always keep the LP gas tank in an upright position. Do not subject the LP gas tank to excessive heat.
- **Never** store an LP gas tank indoors. If you store your gas grill indoors, **always** disconnect the LP gas tank first and store it safely outside.
- LP gas tanks must be stored outdoors in a well-ventilated area and out of the reach of children.
- Disconnected LP gas tanks must not be stored in a building, garage, or any other enclosed area.
- The regulator and hose assembly can be seen after opening the door and must be inspected before each use of the grill. If there is excessive abrasion or wear or if the hose is cut, it must be replaced prior to using the grill again.
- **Never** light your gas grill with the lid closed or before checking to ensure the burner tubes are fully seated over the gas valve orifices.



- **Never** allow children to operate your grill. Do not allow children or pets to play near your grill.
- Use of alcohol or drugs may impair the ability to assemble and operate the appliance.
- Keep a fire extinguisher readily accessible. In the event of an oil or grease fire, do not attempt to extinguish with water. Use a Type B extinguisher or smother with dirt, sand, or baking soda.
- In the event of rain, cover the grill and turn off the burner and gas supply.
- Use your grill on a level, stable surface and ensure the locking casters are locked before use.
- Do not leave the grill unattended when in use.
- Do not move the appliance when in use.
- Allow the grill to cool before moving or storing.
- Do not use your grill as a heater.  
This grill is not intended to be installed in or on recreational vehicles and /or boats.

 **WARNING** 

A. Do not store a spare LP gas tank under or near this appliance.

B. Never fill the tank beyond 80 percent full;

C. If the information in "(a)" and "(b)" is not followed exactly, a fire causing death or serious injury may occur.

 **WARNING** 

**Use your grill at least 3 feet away from any wall or surface.** Use your grill at least 3 feet away from combustible objects that can melt or catch fire (such as vinyl or wood siding, fences and overhangs) or sources of ignition including pilot lights on water heaters and live electrical Appliances.

**Never** use your gas grill in a building, garage, porch, shed, breezeway, boat, or any other enclosed area.

**Never** obstruct the flow of ventilation air around your gas grill housing.

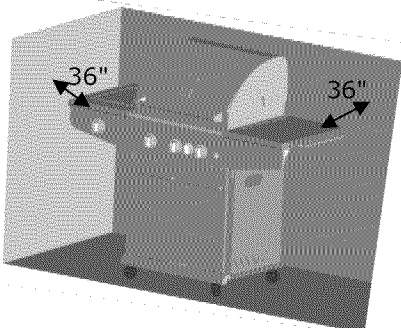

The diagram shows a gas grill on a stand with a cabinet below. Two arrows point from the sides of the grill to the text '36"', indicating the required clearance from walls or other surfaces.

## Notes about LP Gas Tank Exchange Programs

- Many retailers that sell grills offer you the option of replacing your empty LP gas tank through an exchange service. Use only those reputable exchange companies that inspect, precision fill, test and certify their tanks. Exchange your tank only for an OPD safety feature equipped tank as described in the LP gas tank section of this manual.
- Always keep new and exchanged LP gas tanks in an upright position during use, transit or storage.
- Leak test new and exchanged LP gas tanks BEFORE connecting one to your grill.

## How to Leak Test your LP Gas Tank

### For your safety:

- All leak tests must be repeated each time your LP gas tank is exchanged or refilled.
  - Do not smoke when checking for gas leaks.
  - Do not use an open flame to check for gas leaks.
  - Your grill must be leak tested outdoors in a well-ventilated area, away from ignition sources such as gas fired or electrical appliances. During the leak test, keep your grill away from open flames or sparks.
  - Do not use household cleaning agents as damage to gas assembly components can occur.
- Use a clean paintbrush and a 50/50 mild soap and water solution.
  - Brush soapy solution onto the LP gas tank in the areas indicated by the arrows. See diagram.
  - If growing bubbles appear do not use or move the LP Gas tank. Call an LP gas supplier or your fire department.

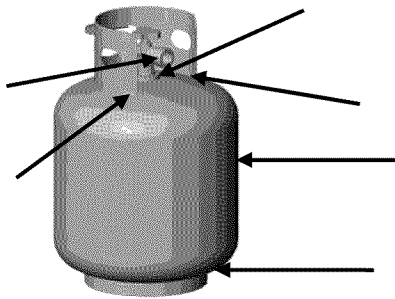

If growing bubbles appear do not use or move the LP Gas tank. Contact an LP gas Supplier or your fire department!

## Regulator and LP Cylinder Connections



The gas pressure regulator provided with this outdoor cooking appliance must be used. This regulator is set for an outlet pressure of 11 inches water column.

### Regulator:

Your regulator is equipped with a Q.C.C. Type 1 quick connect system. It will not allow gas to flow until a positive seal has been made. It has a thermal element that will shut off the gas flow if the temperature reaches 240 degrees F (115 degrees C). It also has a flow-limiting device that will restrict the flow of gas to 10 cubic feet per hour (0.28 cubic meters per hour).

### TO CONNECT THE CYLINDER TO THE REGULATOR AND HOSE

- Be sure the LP cylinder is "OFF" by turning the hand wheel clockwise until it stops.
- Place the cylinder into the base cabinet shelf of the grill with the valve facing outward and secure with the cylinder support ring.
- Be sure all burner controls are turned to the "OFF" position.
- Remove the safety cap from the cylinder valve.
- Center the nipple of the regulator into the cylinder valve.
- Turn the black nut clockwise until it stops.

**Hand Tighten Only. Do Not Use A Wrench.**

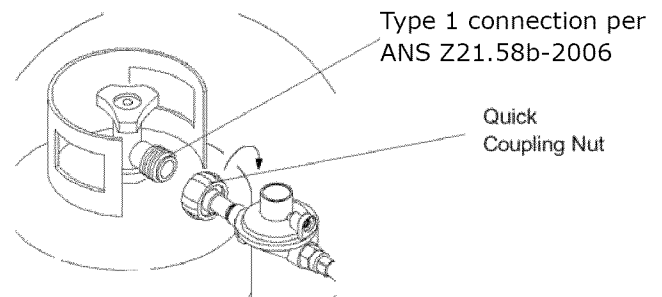

**CAUTION:** When the appliance is not in use the gas must be turned off at the tank.

## Flow Limiting Valves on LP Gas Tanks

Your LP gas tank is equipped with a flow limiting valve that will restrict the flow of gas due to a sudden change in pressure. This can often activate without your knowledge. You will notice among other things that your grill does not get as hot as it should, will take longer to heat up, or you may not be able to light all burners. If you notice any of the above, then you should reset the valve and clear your gas line.

To do this

1. Ensure the LP gas tank valve is OFF.
2. Disconnect the regulator from the LP gas tank.
3. Open all burner control knobs including the side burner to Hi at the same time.
4. Close all burner control knobs to OFF.
5. Let the LP gas tank stand for at least 10 minutes.
6. Reconnect the regulator assembly to the LP gas tank.
7. Slowly, meaning about 1/4 turn at a time, turn on the LP gas valve.
8. Follow the burner lighting procedures to light the burner farthest away from the gas source.
9. The flow limiting valve should now be reset.

This flow limiting valve is triggered by sudden changes in pressure. This can be caused by a leak, faulty connection of the regulator to the LP gas tank, turning on the LP gas tank valve too quickly, or turning the burners off by turning the LP gas tank valve off before turning the burner control knobs to off. Note: always turn off your burners using the burner control knobs first before turning the LP gas tank valve off.

## Transportation and Storage

1. Place dust cap on the cylinder valve outlet whenever the cylinder is not in use. Only install the type of dust cap on the cylinder valve outlet that is provided with the cylinder valve. Other types of caps or plugs may result in leakage of propane.
2. Always transport your cylinder in an upright position.
3. Do not smoke when transporting your cylinder.

## Check all connections for LP Gas Leaks



**Never** test for leaks with a flame. Prior to first use, at the beginning of each season or every time your LP Gas tank is changed you must check for gas leaks. Follow these three steps:

Make a soap solution by mixing one part liquid detergent and one part water

Turn the burner control knobs to the OFF position. Then turn the gas ON at the source.

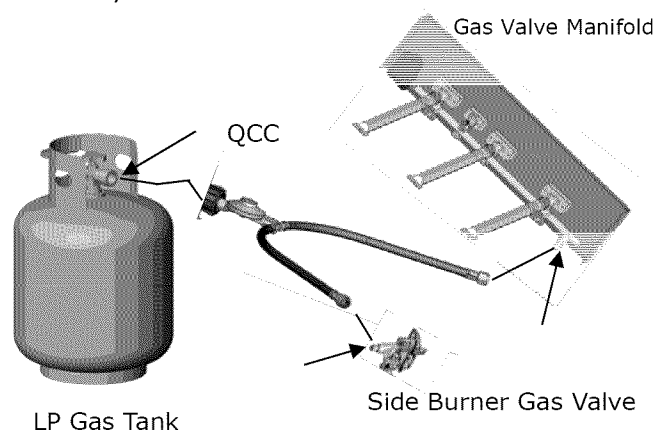
Apply the soap solution to all gas connections indicated by the arrows. See diagram. If bubbles appear in the soap solution the connections are not properly sealed. Check each fitting and tighten or repair as necessary.



	<b>WARNING</b>	
<p>If you have a gas leak that cannot be repaired by tightening, turn off the gas at the source, disconnect fuel line from your grill and call 1-800-4-MY-HOME® or your gas supplier for repair assistance.</p>		



## Disconnecting A Liquid Propane Gas (LPG) Tank From Your Grill

- Make sure the burner valves and LP gas tank valve are off. (Turn clockwise to close.)
- Detach the hose and regulator assembly from the LP gas tank valve by turning the quick coupling nut counterclockwise

## USE AND CARE INSTRUCTIONS

### Grill Lighting Instructions

1. Before each use, check all hoses for cracks, nicks, cuts, or abrasions. If a hose is damaged in any way, do not use your grill before replacing the hose with an authorized part from the Parts List. Also make sure all gas supply connections are securely tightened.
2. Familiarize yourself with the Safety and Use and Care instructions in this manual. Do not smoke while lighting the grill or checking gas supply connections.
3. Be sure the LP gas tank has gas.
4. Open the grill lid.

**WARNING**

Failure to replace a faulty hose, secure gas supply connections, or to open the lid before proceeding to the Lighting Procedures could result in a fire or explosion that could cause serious bodily injury, death, or property damage.

5. Set control knobs to OFF and open the LP gas tank valve SLOWLY.

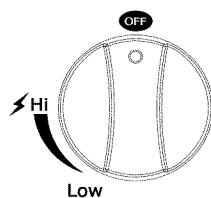

6. Push and turn any control knob to "Hi".

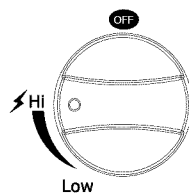

7. Immediately press the electronic ignition button for 3-5 seconds to light the burner. You should hear a clicking sound which shows the electronic ignition is working. If the burner does not light within 5 seconds, turn the burner control knob to "OFF". Wait 5 minutes for the gas to clear, and repeat the above procedure.
8. Once one burner is lit, an adjacent burner can be lit by turning its control knob to "Hi".
9. When lit, turn the control knob to its desired setting.

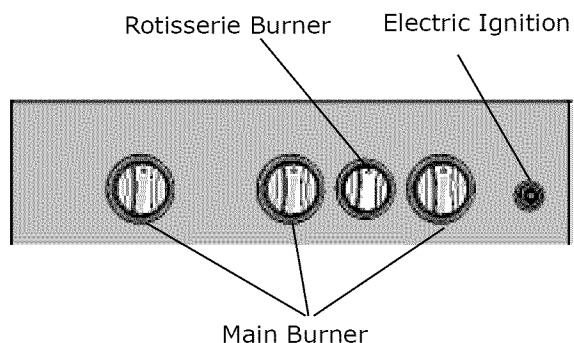

### Side Burner and Rotisserie Burner Lighting Instructions

1. Follow steps 1 through 3 of the Grill Lighting Instructions.
2. Open the grill lid or side burner cover.
3. Set control knobs to OFF and open the LP gas tank valve SLOWLY
4. Push and turn the control knob to "Hi".
5. Immediately press the electronic ignition button for 3-5 seconds to light the burner. You should hear a clicking sound which shows the electronic ignition is working.
6. If the burner does not light within 5 seconds, turn the burner control knob to "OFF". Wait 5 minutes for the gas to clear, and repeat the above procedure.
7. Continue to press in and hold the rotisserie burner control knob for 5 to 7 seconds once lit to activate the safety flame sensor. Failure to do so will cause gas to be shut off to the rotisserie burner and the burner will go out.

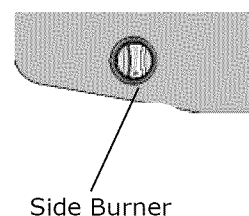

## USE AND CARE INSTRUCTIONS

### MANUALLY LIGHTING THE BURNERS WITH THE MATCH HOLDER

1. Open the lid
2. Ensure all burners are in the "OFF" position.
3. Slowly turn on the gas at the LP cylinder valve if it is not already on.
4. Place a match in the manual igniter stick. This is located inside the left cabinet door.
5. Use the stick to slide the lit match through the cooking grates and the front of the heat diffuser to the burner you wish to light.
6. Press and turn the burner control knob to "Hi". Continue to push in and hold up to 5 seconds or until the burner lights.
7. If the burner does not light within 5 seconds, turn the burner control knob to "OFF". Wait 5 minutes for gas to clear and try again.
8. When lit, turn the control knob to the desired heat setting.
9. Light an adjacent burner with a lit burner by turning its control knob to "Hi".

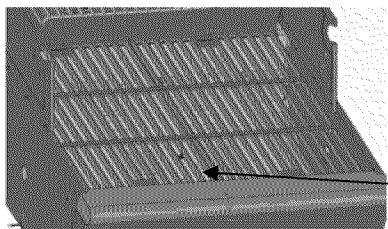



Manual igniter stick

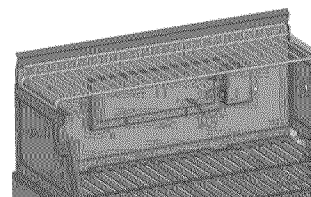
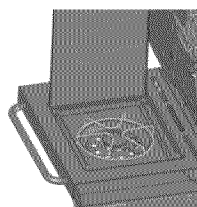

### MANUALLY LIGHTING THE SIDE BURNER OR THE ROTISSERIE BURNER

1. Open the grill lid or side burner cover.
2. Ensure the control knob is in the "OFF" position as well as any main burner not in use.
3. Slowly turn on the gas if it is not already on.
4. Strike the match, and place near the top of the burner.
5. Push in and turn the control knob to "Hi"
6. If the burner does not light within 5 seconds, turn the burner control knob to "OFF". Wait 5 minutes for the gas to clear, and try again.
7. When lit, turn the control knob to the desired heat setting.
8. Continue to press in and hold the rotisserie burner control knob for 5 to 7 seconds once lit to activate the safety flame sensor. Failure to do so will cause gas to be shut off to the rotisserie burner and the burner will go out.



 **WARNING** 

1. Do not use charcoal briquettes, lava rock, or any type of ceramic product in this grill.
2. Do not put a barbecue cover or other flammable material in the storage area of this grill.

 **WARNING** 

**Never** lean over the grill cooking area while lighting your gas grill. Keep your face and body a safe distance (at least 18 inches) from the lighting hole and burners when lighting your grill with a match.

## USE AND CARE INSTRUCTIONS

### Troubleshooting

#### If the grill fails to light:

1. Turn gas off at source and turn control knobs to "OFF". Wait at least 5 minutes for gas to clear, and then retry
  2. If your grill still fails to light, check the gas supply and connections. Ensure gas supply is turned on (turn counterclockwise), there is gas in the tank, and the regulator is properly seated in the tank valve.
  3. Repeat lighting procedure. If your grill still fails to light, turn the gas off at the source, turn the control knobs to "OFF", and check the following:
  4. Check that the end of each burner tube is properly located over each valve orifice.
- Obstruction in Gas Line  
**Correction:** Detach regulator hose assembly. Do not smoke! Open all control knobs at the same time to "Hi". Close all burner control knobs to "OFF" and reattach the regulator hose assembly to the grill.
  - Plugged Orifice or Burner Tube Obstruction  
**Correction:** Remove burners from grill and clean following the burner cleaning instructions later in this manual. Observe valve orifice to be sure there is no obstruction visible.
  - If an obstruction is suspected in Gas Valve or Manifold, call the Customer Support Center.
  - Misalignment of Igniter and Burner  
**Correction:** Check for proper position of the electrode tip. The gap between the electrode tip and burner should be approximately 3/16 of an inch. Adjust if necessary. With the gas supply off and all control knobs set to "OFF" press the electric igniter button and check for the presence of a spark at the electrode.
  - Disconnected Electric Wires  
**Correction:** Inspect the electronic igniter (see Parts List) found behind the control panel. Connect loose electric wires to ignition assembly.
  - Weak AA Battery  
**Correction:** Unscrew the igniter cap and replace the battery.



 **WARNING** 

Do not dispose of batteries in fire! Batteries may explode or leak.

- If the grill still does not light you may need to reset the flow limiting valve in your LP tank.  
**Note:** This procedure should be done every time a new LP gas tank is connected to your grill.

#### Follow the steps below to reset the flow limiting device.

- Turn LP gas tank valve "OFF".
- Disconnect the regulator assembly from LP Gas tank.
- Open all burner control knobs to "Hi" at the same time.
- Close all burner control knobs to "OFF"
- Let the LP Gas tank stand for at least 10 minutes.
- Reconnect the regulator assembly to the LP Gas tank.
- Slowly turn on the LP Gas tank valve.
- Follow the burner lighting procedures to light the burner farthest away from the gas source.

 **WARNING** 

Should a FLASHBACK fire occur in or around the burner tubes, follow the instructions below. Failure to comply with these instructions could result in a fire or explosion that could cause serious bodily injury, death, or property damage.

- Shut off gas supply (turn the LP tank valve clockwise) to the gas grill.
- Turn the control knobs to the "OFF" position.
- Open the grill lid.
- Put out any flame with a Class B Fire extinguisher
- Once the grill has cooled down, clean the burner tubes and burners according to the cleaning instructions in this Operator's Manual.

### Customer Support Center

Call 8:30 AM to 5:00 PM CST **1-800-933-0527** Monday through Friday.



## CLEANING AND MAINTENANCE

Proper care and maintenance will keep your grill in good operating condition and prolong its life. Follow these cleaning procedures on a timely basis and your grill will stay clean and operate with minimum effort.

**CAUTION:** Be sure your grill is off and cool before cleaning, and always wear protective gloves when cleaning your grill.

### Cleaning The Cooking Grates

Wash your cooking grates in a mild soap and warm water solution. You can use a wash cloth, vegetable brush, or brass bristled brush.

Never use any type of steel bristled brush. Dry them when finished.

### Cleaning the Heat Diffusers

Wash the heat diffusers periodically in a soap and warm water solution. Use a vegetable brush to remove stubborn burnt-on cooking residue. Dry the heat diffusers thoroughly before you reinstall them into the firebox.

### Cleaning the Grease Tray and Pan

To reduce the chance of fire, the grease tray and grease pan should be visually inspected before each grill use. Remove any grease and wash both with a mild soap and warm water solution.

### Cleaning the Inside of the Grill Lid

Grease can have a tendency to build up on the inside of the grill lid and could drip onto the deck or patio when the lid is opened. Visually inspect the inside of the grill lid before each grill use. Remove any grease and wash with a mild soap and warm water solution.

### Annual Cleaning of the Grill Interior

Burning-off excess food after every cookout will keep it ready for instant use. We recommend you periodically give the entire grill a thorough cleaning to minimize your risk of grease fire and keep the grill in good shape. Follow these steps:

1. Turn all burner valves to the "OFF" position.
2. Turn the LP gas tank valve to the "OFF" position.
3. Disconnect the regulator assembly from the gas tank. Inspect the hose for cracking, cuts or any other damage, and replace as necessary. Refer to the Parts List in this Operator's Manual.
4. Remove and clean the cooking grates, heat diffusers, warming rack, burners, and grease tray.
5. Cover each gas valve orifice with aluminum foil.
6. Brush the inside and bottom of the grill with a fiber pad or nylon brush and wash with a mild soap and warm water solution. Rinse thoroughly and let dry.
7. Remove aluminum foil from orifices and check each orifice for obstruction.
8. Replace the burners, ensuring the burners fit

down over each valve orifice.

9. Check and clean each electrode tip. Adjust the spacing between the tips and the burner as necessary. The space between the electrode tip and burner should be approximately 3/16".
10. Replace the heat diffusers, grates, warming rack, and grease tray.
11. Reconnect the gas source and observe the burner flame for correct operation.

### Cleaning Exterior Surfaces:

#### Cleaning Exterior Surfaces:



Wash with a mild dish soap and warm water solution. A cloth, soft brush, or plastic cleaning pad can be used. Rinse thoroughly and wipe dry.

#### Cleaning Exterior Stainless Steel Surfaces:

Wash with a mild dish soap and warm water solution. Clean and polish with a stainless steel cleaner. There are many good quality stainless steel cleaners and polishes available. Follow the manufacturer's directions. Always polish in the direction of the lines. Do not allow dirt and grease to accumulate. Do not use steel wool as it will scratch the surface. Do not use abrasive cleaners and scrubbers.

### CAUTION:

Heat, weathering, machine oils used in the manufacturing of stainless steel, and dirt can all cause exterior stainless steel surfaces to turn tan in color. In addition, the following products and naturally occurring substances in the outdoors will damage all stainless steel finishes. Use caution so they will not come in contact with your grill. Immediately wash them off and dry the stainless steel should they ever come in contact with your gas grill. They include, but are not limited to, pool chemicals (chlorine and bromine), lawn fertilizer, ice melting salts, sea or salt water, urine, bird droppings, and tree sap.

	<b>WARNING</b>	
<p>Failure to comply with these instructions may result in a hazardous situation which, if not avoided, may result in injury. Keep grill area clear and free from combustible materials, gasoline and other flammable vapors and liquids. Do not obstruct the flow of air for combustion and ventilation. Keep the ventilation openings of the tank enclosure cabinet free and clear of debris.</p>		

## CLEANING THE BURNER TUBES AND BURNER PORTS

To reduce the chance of **FLASHBACK FIRE** you must clean the burner tubes as follows periodically in summer and fall, wherever spiders are active in your area, and if your grill has not been used for an extended period of time.

1. Turn all burner control knobs to the "OFF" position.
2. Turn the LP gas tank valve to the "OFF" position.
3. Disconnect the LP gas regulator assembly from the LP gas tank.
4. Remove the cooking grates, heat tents, and warming rack from the grill.
5. Remove the screw from the rear of each burner using a Phillips head screwdriver.
6. Carefully lift each burner up and away from the gas valve orifice.
7. Check and clean burner tubes for insects and insect nests. A clogged tube can lead to a fire beneath the grill.
8. Use one of these three cleaning methods:  
**METHOD 1:** Bend a stiff wire or wire coat hanger into a small hook as shown and run the hook through the burner tube and inside the burner several times to remove debris.



**METHOD 2:** Use a bottle brush with a flexible handle and run the brush through the burner tube and inside the burner several times to remove any debris.

**METHOD 3:** Use an air hose to force air through each burner tube. The forced air should pass debris or obstructions through the burner and out the ports. Always wear eye protection if using this method.

Regardless of the burner cleaning procedure you use, we recommend you also complete the following steps to help prolong burner life.

1. Use a fiber pad or nylon brush to clean the entire outer surface of each burner until free of food residue and dirt.
2. Clean any clogged ports with a stiff wire, such as an open paper clip.
3. Inspect each burner for damage (cracks or holes) and if such damage is found, order and install a new burner. After installation, check to ensure that the gas valve orifices are correctly placed inside the ends of the burner tubes. Also check the position of your electrodes.
4. Never enlarge the burner ports during cleaning.

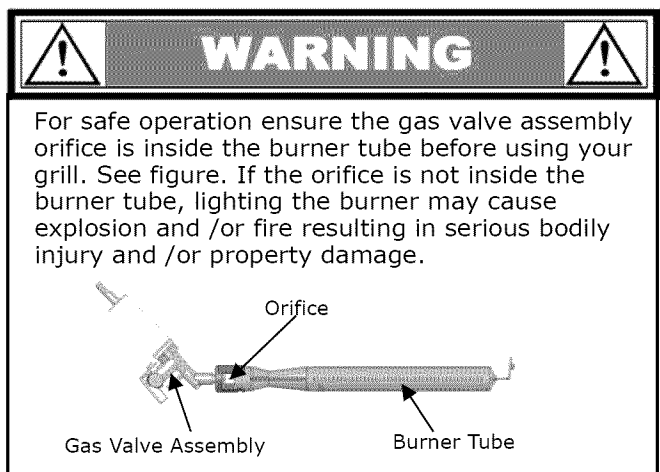

### BURNER FLAMES

Always inspect the burner flame after lighting. A good flame should be primarily blue with a yellow tip and have a minimum amount of noise. Some yellow tips are OK if under one inch. New burners sometimes have oil residue, which will cause yellow flame when burning off. Variations in gas supply, altitude, weather, and other factors can all impact burner performance. Older grills can also show more yellow flame as food deposits, oils, and fats can build up.

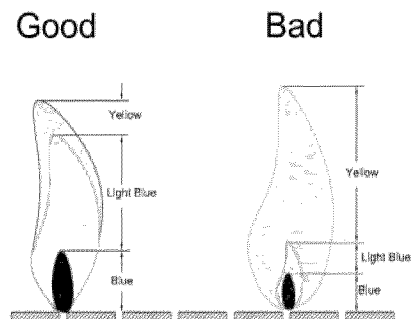

**WARNING**

Small insects, such as spiders, are able to access the burner tubes. Sometimes they will build nests or spin webs. In either case, this can block or reduce the amount of gas flowing through the burner. You will usually see a smaller flame, or a flame that is mostly yellow rather than blue, coming from the burner when this happens. Other signs include the grill not heating evenly, not reaching temperature, or burners not igniting. In cases with severe blockage, this can cause the flame to burn backwards, and outside of the burner tubes, which can cause damage to your grill and/or personal injury. **IMMEDIATELY SHUT OFF THE FLOW OF GAS AT THE LP TANK OR NATURAL GAS VALVE SHOULD THIS HAPPEN.** Wait for the grill to cool, and then clean all burners.

## Cooking Instructions

### Burn-Off

Some of the new parts of your grill could have residual oils. We recommend you ignite the burners, turn to "Hi", and lower the lid for 3 to 5 minutes to burn any oils off before grilling for the first time. **CAUTION:** Operating your grill on the "Hi" setting for longer than fifteen minutes may damage certain parts of your grill.

### Preheating

To preheat, light your grill on "Hi", lower the lid, and follow this timetable: for high temperature cooking, preheat grill 3 to 5 minutes; for low temperature cooking, preheat grill 3 minutes. Preheating is not necessary to slow cook.

### Cooking Temperature

**High Setting:** The "Hi" control knob setting should only be used to sear some meats, pre-heat your grill the first 3-5 minutes and for burning food residue off the grill for 3-5 minutes after cooking is complete. Never use the "Hi" setting for extended cooking.

**Medium to Low Settings:** Most recipes specify medium to low settings, including all smoking and rotisserie cooking, lean cuts of meat, chicken, and fish.

### An Important Note About Cooking Temperature

The outside grilling area is not the controlled environment that your indoor kitchen is. Many variables can impact the cooking performance of your grill, including outside air temperature, wind, humidity, and altitude. Allow more cooking time for cold, wind, and higher altitudes. We recommend you place the grill in an area protected from wind. Monitor your grill closely and rotate foods as needed to prevent overcooking and ensure the most delicious results every time. Experimenting makes grilling more fun and interesting!

The middle and back primary cooking areas offer the highest heat for searing and grilling.

The warming rack offers medium heat for preparing breads and firm vegetables like potatoes and corn and keeping food warm.

The front primary cooking area offers less heat and is ideal for preparing delicate foods and also for keeping cooked foods warm.

### Direct Cooking

The direct cooking method is used when food is placed directly over the lit grill burners. This method is ideal for searing, grilling, deep frying and whenever you want foods to have an open-flame barbecued taste. The lid can be open or closed depending on your preference.

### Indirect Cooking

The indirect cooking method is used for most foods.

Do not place the food directly over a burner to use this method. Instead, the food should be placed on the left or right side of your grill with the burner lit on the opposite side or in the center with the center burners off. Indirect cooking must be done with the lid down.

### Prepare Cooking Grates for Grilling

Greasing the cooking surface will help keep foods from sticking and reduce the amount of cleanup required. Use a brush to apply a thin layer of cooking oil or vegetable shortening onto each cooking grate. We do not suggest spray type oils unless they are specified for high-temperature cooking. Be sure to coat the entire cooking surface including edges and any areas with chipped porcelain.

### Flare-Ups



The fats and juices dripping from grilled food can cause flare-ups. Flare-ups work to color and flavor your foods, so some flare-ups are preferred. Too many can work against you though. Reduce flare-ups by trimming away excess fat, using the indirect method of grilling, and grilling using lower temperatures.

### Using the Back Burner (If Equipped)

The back burner is used when cooking with a rotisserie, which is sold separately. Please follow the points below when using the back burner.

1. Always remove the warming rack.
2. Do not use the main burners when the back burner is in use.
3. Use an aluminum foil pan to catch the juices that drip down from the food.

Allowing grease to gather in the bottom of the firebox could create a grease fire the next time the main burners are used.

 **WARNING** 

**Never** line the bottom of the firebox with aluminum foil, sand or any substance that will restrict the flow of grease into the grease tray or cup.

**Before each use**, pull out the grease tray and remove all grease and food debris to prevent a grease fire hazard.

**Your grill will get very hot.** Always wear a flame retardant BBQ Mitt when cooking on your grill. Never lean over cooking areas while using grill. Do not touch cooking surfaces, lid, grill housing or other parts while grill is in operation, or until the grill has cooled down after use.

## FREQUENTLY ASKED QUESTIONS

**Question:**

**Can I convert my gas grill from one fuel type to another, such as LP to NG (natural gas) or vice versa?**

**Answer:**

No, your gas grill is manufactured to specific standards developed by CSA and ANSI for your safety and is certified for one type of gas only.

**Question:**

**Are the serial and model numbers of my grill listed somewhere for reference?**

**Answer:**

The serial and model numbers are listed on a silver CSA label placed on the grill. Depending on the grill model, the silver CSA label generally will be located inside the left door of the cabinet.

**Question:**

**My grill will not light properly. Why?**

**Answer:**

Check these possibilities:

1. The gas supply is turned off at the LP tank. Turn on the gas at the LP tank.
2. Your LP tank is out of propane.
3. The regulator is not properly seated in the tank valve. Remove and reattach. Hand tighten only.
4. Crimped fuel supply hose. Inspect and straighten.
5. Regulator failure or damaged hose assembly. Inspect and order a replacement part. Do not use your grill if you find a damaged hose assembly.
6. Gas not getting to the burners. Inspect the burners under the control panel to be sure they are aligned with the valve orifices.
7. Blockage in the gas system. Inspect burners and valve orifices for blockages, such as spider webs, insects, etc. Clean as necessary.

**Question:**

**My electronic ignition is not working.**

**Answer:**

Listen to hear the electronic igniter clicking. If not, check these possibilities:

1. Replace the AA battery. Ensure the "+" end is facing up and out.
2. Ensure the battery is centered and fits into

- the electronic ignition button properly.
3. Be sure the wires are all attached to the electronic ignition assembly behind the control panel and the individual electrodes.
4. Inspect the electrodes to be sure they are not coated with grease or dirt. If so, clean with rubbing alcohol.

If you hear a clicking sound, then:

1. Inspect the electrodes to be sure they are not coated with grease and dirt. Clean with rubbing alcohol.
2. Inspect the distance from the electrode to the burner. It should be 1/8 to 1/4 inch from the main burner and 1/8 to 3/16 inch from the side burner.

**Question:**

**Sometimes I hear a humming sound coming from my regulator. What causes this?**

**Answer:**

The humming sound is gas flowing through the regulator. This is more likely to occur in periods of high gas flow. A low volume of sound is normal and will not interfere with the operation of your grill.

**Question:**

**My grill has a low flame on some burners, or some burners will not light at all. What can cause this?**

**Answer**

This can be caused by the flow limiting device, which is generally triggered by a sudden change in pressure. Opening the tank valve too fast or shutting the burners off using the tank valve can cause this. To reset:

1. Close the LP tank valve and disconnect the regulator assembly from the tank.
2. Let the LP tank sit for 10 minutes.
3. Open all burner control knobs, including the side burner, to "Hi" at the same time.
4. Close all burner control knobs.
5. Reconnect the gas regulator to the LP tank.
6. Follow the burner lighting procedures and light the burner farthest from the LP tank.

## FREQUENTLY ASKED QUESTIONS

### Question:

**Where do I use my grill for safer operation and better performance?**

### Answer:

Strong winds and low temperatures can affect the heating and performance of your gas grill so factor in these elements when positioning your grill outdoors for cooking.

Use your grill at least 3 feet away from any wall or surface.

Use your grill at least 3 feet away from combustible objects that can melt or catch fire (such as vinyl or wood siding, fence and overhangs) or sources of ignition including pilot lights on water heaters and live electrical appliances.

Never use your gas grill in a garage, porch, shed, breezeway or any other enclosed area.

Never obstruct the flow of ventilation air around your gas grill housing.

### Question:

**The regulator and hose supplied with my gas grill does not fit the older LP Gas Tank I've used for years. Why not?**

### Answer:

The U.S. Government regulates gas appliances and LP gas tanks. When regulations are changed the LP gas tank fittings are altered to insure compliance. If your LP gas tank does not fit the regulator and hose assembly supplied with your new grill, then the tank is outdated and must be replaced. Note: Effective April 1, 2002 all LP gas tanks sold must include an "OPD" Overfill Prevention Device. The OPD tanks are identified by their triangular-shaped valve wheel. This internal device prevents the LP gas tank from being overfilled. Tanks without an OPD valve can no longer be refilled.

### Question:

**Is it safe to clean my porcelain coated cooking grates in the dishwasher?**

### Answer:

No. You should not clean any grill parts in your dishwasher. We recommend you clean all parts of your grill, including the cooking grates, by hand.

### Question:

**Can I clean parts of my grill, such as the cooking grates and heat diffusers in a self-cleaning oven?**

### Answer:

No. You should not clean any part of your grill in a self-cleaning oven.

### Question:

**What can I do to keep my cast iron grates from rusting?**

### Answer:

Cast iron grates do require special care. We recommend you first season new grates. Wash new grates with dishwashing liquid, rinse, and dry completely with a soft cloth. Never wash them in a dishwasher. We recommend you use a solid vegetable shortening over the grates to season them the first time. Spread a thin coating with a paper towel over the entire surface, corners, and edges. Preheat your grill to 500 degrees. Turn half your burners to "LOW" and half "OFF", and place grates in the firebox for about an hour. Shut off all burners and allow the grates to cool. We recommend you coat the grates with a liquid vegetable oil before each use. We do not suggest spray type oils unless they are specified for high temperature cooking.

## Repair Protection Agreements

Congratulations on making a smart purchase. Your new Kenmore® product is designed and manufactured for years of dependable operation. But like all products, it may require repair from time to time. That's when having a Repair Protection Agreement can save you money and aggravation.

Here's what the Repair Protection Agreement\* includes:

- ☑ **Expert service** by our 10,000 professional repair specialists
- ☑ **Unlimited service and no charge** for parts and labor on all covered repairs
- ☑ **Product replacement** up to \$1500 if your covered product can't be fixed
- ☑ **Discount of 10%** from regular price of service and related installed parts not covered by the agreement; also, 10% off regular price of preventive maintenance check
- ☑ **Fast help by phone** – we call it Rapid Resolution- phone support from a Sears representative, Think of us as a “talking owner’s manual.”

Once you purchase the Repair Protection Agreement, a simple phone call is all that it takes for you to schedule service. You can call anytime day or night, or schedule a service appointment online.

The Repair Protection Agreement is a risk-free purchase. If you cancel for any reason during the product warranty period, we will provide a full refund.

Or, a prorated refund anytime after the product warranty period expires. Purchase your Repair Protection Agreement today!

**Some limitations and exclusions apply. For prices and additional information in the U.S.A. CALL 1-800-827-6655.**

**\*Coverage in Canada varies on some items. For full details call Sears Canada at 1-800-361-6665**

### **Sears Installation Service**

For Sears professional installation of home appliances, garage door openers, water heaters, and other major home items, in the U.S.A. or Canada call **1-800-4-MY-HOME®**

# Get it fixed, at your home or ours!

## Your Home

For expert troubleshooting and home solutions advice:

manage  home

[www.managemyhome.com](http://www.managemyhome.com)

For repair – **in your home** – of **all** major brand appliances, lawn and garden equipment, or heating and cooling systems, **no matter who made it, no matter who sold it!**

For the replacement parts, accessories and owner's manuals that you need to do-it-yourself.

For Sears professional installation of home appliances and items like garage door openers and water heaters.

**1-800-4-MY-HOME<sup>®</sup>** (1-800-469-4663)

Call anytime, day or night (U.S.A. and Canada)

[www.sears.com](http://www.sears.com)    [www.sears.ca](http://www.sears.ca)

## Our Home

For repair of carry-in items like vacuums, lawn equipment, and electronics, call anytime for the location of your nearest

**Sears Parts & Repair Service Center**

**1-800-488-1222** (U.S.A.)    **1-800-469-4663** (Canada)

[www.sears.com](http://www.sears.com)    [www.sears.ca](http://www.sears.ca)

To purchase a protection agreement on a product serviced by Sears:

**1-800-827-6655** (U.S.A.)    **1-800-361-6665** (Canada)

Para pedir servicio de reparación a domicilio, y para ordenar piezas:

**1-888-SU-HOGAR<sup>®</sup>**

(1-888-784-6427)

Au Canada pour service en français:

**1-800-LE-FOYER<sup>MC</sup>**

(1-800-533-6937)

[www.sears.ca](http://www.sears.ca)

