

Use & Care Guide



Charcoal - Gas Combo Grill

Sears Model No.: 122.16431010
Kmart Item No.: 640-01350178-8

- Safety
- Parts
- Use and Care
- Assembly

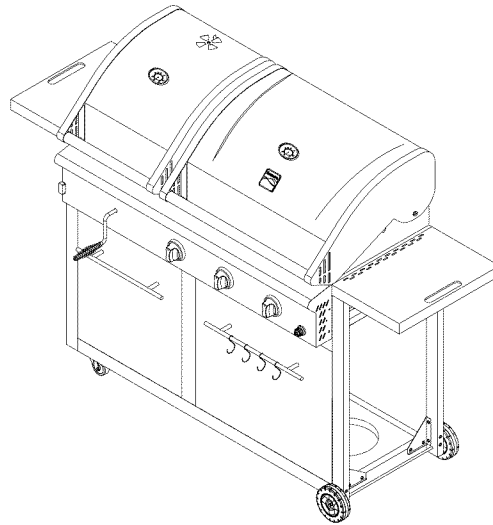

This Grill is for Outdoor Use Only

	WARNING	
<p>•Read and follow all Safety, Assembly, and Use and Care Instructions in this Guide before assembling and cooking with this grill.</p> <p>•Failure to follow all instructions in this Use and Care Guide may lead to fire or explosion, which could result in property damage, personal injury or death.</p>		

Grill Information Center

Missing Parts? Assembly Questions?
Operation Problems? Before returning
grill to store, call 1-800-913-8999.

Tools needed for assembly:

- Adjustable wrench (not provided)
- Screwdriver (not provided)
- 7/16" Combination wrench (not provided)

SAVE THESE INSTRUCTIONS!

See our extensive assortment of outdoor living products on-line at
[www. Sears. com](http://www.Sears.com) and [www. Kmart . com](http://www.Kmart.com)

Sears Brands Management Corporation, Hoffman Estates, IL 60179 U.S.A.

Table of Contents

Warranty-----	2
Safety Precautions-----	2
Packaging Content List-----	5
Hardware Pack-----	7
Preparation-----	7
Assembly Instructions-----	7
Lighting Instructions-----	16
Cleaning and Maintenance for Gas Grill-----	18
Troubleshooting-----	19
Charcoal Grill Information-----	20
Charcoal Grill Lighting Instructions-----	21
Cooking Chart-----	22
Parts Diagram-----	23
Parts List-----	24

Kenmore Grill Warranty

One-Year Full Warranty on Kenmore Grill

If this grill fails due to a defecting material or workmanship within one year from the date of purchase, call 1-800-4-MY-HOME to arrange for free repair (or replacement if repair proves impossible).

Ten-Year Limited Warranty on Stainless Steel Burners

For ten years from the date of purchase, any stainless steel burner that rusts through will be replaced free of charge. After the first year from the date of purchase, you pay for labor if you wish to have it installed.

All warranty coverage excludes ignitor batteries and grill part paint loss, discoloration or rusting, which are either expendable parts that can wear out from normal use within the warranty period, or are conditions that can be the result of normal use, accident or improper maintenance.

All warranty coverage is void if this grill is ever used for commercial or rental purposes.

All warranty coverage applies only if this grill is used in the United States.

This warranty gives you specific legal rights, and you may have other right which vary from state to state.

Sears, Roebuck, and Co.
Hoffman Estates, IL 60179 U.S.A.

Precautions

WARNING

Combustion by products produced when using this product contain chemicals known to the State of California to cause cancer, birth defects, or other reproductive harm.

WARNING

Failure to comply with these instructions could result in a fire or explosion that could cause serious bodily injury, death, or property damage.

WARNING

Your grill will get very hot. Never lean over the cooking area while using your grill. Do not touch cooking surfaces, grill housing, lid or any other grill parts while the grill is in operation, or until the gas grill has cooled down after use.

Failure to comply with these instructions may result in serious bodily injury.

WARNING

- 1. Do not store or use gasoline or other flammable liquids or vapors in the vicinity of this or any other appliance.**
- 2. An LP cylinder not connected for use shall not be stored in the vicinity of this or any other appliance.**

DANGER

If you smell gas:

- 1. Shut off gas to the appliance.**
- 2. Extinguish any open flame.**
- 3. Open lid.**
- 4. If odor continues, keep away from the appliance and immediately call your gas supplier or your fire department.**

Grill Installation Codes

The installation must conform with local codes or, in the absence of local codes, with either the national fuel gas code, ANSI Z 223.1/NFPA S4, Natural gas and propane installation code, CSA B149.1, or propane storage and handling code, B149.2, or the standard for Recreational vehicles, ANSI A 119.2, and CSA Z240 RV series recreational vehicle code, as applicable.

LP gas grill models are designed for use with a standard 20 lb. Liquid Propane Gas tank, not included with grill. Never connect your gas grill to an LP gas tank that exceeds this capacity.

Precautions

A tank of approximately 12 inches in diameter by 18-1/2 inches high is the maximum size LP gas tank to use. **You must use an OPD gas tank which offers an Overfill Prevention Device.**

This safety feature prevents the tank from being overfilled which can cause malfunction of the LP gas tank, regulator and/or grill.

The LP gas tank must be constructed and marked in accordance with specifications of the U.S. Dept. of Transportation (DOT). In Canada, the LP gas tank must meet the National Standard of Canada, Can CSA –B339, Cylinders, spheres and Tubes for Transportation of Dangerous Goods and Commission.

1. The LP gas tank must have a shutoff valve, terminating in an LP gas supply tank valve outlet, that is compatible with a Type 1 tank connection device. The LP gas tank must also have a safety relief device that has a direct connection with the vapor space of the tank.
2. The tank supply system must be arranged for vapor withdraw.
3. The LP gas tank used must have a collar to protect the tank valve.

Proper Placement and Clearance of Grill

Never use your gas grill in a garage, porch, shed, breezeway or any other enclosed area. Your gas grill is to be used **outdoors only**, at least 24 inches from the back and side of any combustible surface. Your gas grill should not be used under overhead combustible construction. Do not obstruct the flow of ventilation air around the gas grill housing.

- Do not install this outdoor gas grill in or on recreational vehicles or boats
- Keep outdoor gas grill area clear and free from combustible materials, gasoline and other flammable vapors and liquids
- Do not obstruct the flow of combustion and ventilation air. Check for this each time prior to using grill.
- **Never** connect an unregulated LP gas tank to your gas grill. The gas regulator assembly supplied with your gas grill is adjusted to have an outlet pressure of 11" water column (W.C.) for connection to an LP gas tank.
- Only use the regulator and the hose assembly supplied with your gas grill. Replacement regulators and hose assemblies must be those specified in this manual.

- Have your LP gas tank filled by a reputable propane gas dealer and visually inspected and re-qualified at each filling.
- Do not store a spare LP gas tank under or near this appliance.
- Never fill the tank beyond 80 percent full. If this information is not followed exactly a fire causing death or serious injury may occur.
- Always keep LP gas tanks in an upright position.
- Do not store (or) or use gasoline or other flammable vapors and liquids in the vicinity of this gas grill.
- Do not subject the LP gas tank to excessive heat.
- Never store an LP gas tank indoors. If you store your gas grill in the garage or other indoor location, **always** disconnect the LP gas tank first and store it safely outside.



- Place dust cap on cylinder valve outlet whenever the cylinder is not in use. Only install the type of dust cap on the cylinder valve outlet that is provided with the cylinder valve. Other types of caps or plugs may result in leakage of propane.
- LP gas tanks must be stored outdoors in a well-ventilated area and out of reach of children. Disconnected LP gas tanks must not be stored in a building, garage or any other enclosed area.
- When your gas grill is not in use the gas must be turned off at the LP gas tank.
- The regulator and hose assembly must be inspected before each use of the grill. If there is excessive abrasion or wear or if the hose is cut, it must be replaced prior to the grill being used again.
- Keep the gas regulator hose away from hot grill surfaces and dripping grease. Avoid unnecessary twisting of hose. Visually inspect the hose prior to each use for cuts, cracks, excessive wear or other damage. If the hose appears damaged do not use the gas grill. Call 1-800-4-MY-HOME for a replacement hose.
- **Never** light your gas grill with the lid closed or before checking to ensure the burner tubes are fully seated over the gas valve orifices.
- **Never** allow children to operate your grill.

⚠ WARNING

A strong gas smell, or the hissing sound of gas indicates a serious problem with your gas grill or the LP gas tank. Failure to immediately follow the steps listed below could result in a fire or explosion that could cause serious bodily injury, death, or property damage.

- Shut off gas supply to the gas grill.
- Turn the control knobs to OFF position.
- Put out any flame with a proper fire extinguisher.
- Open Grill Lid.
- Get away from the LP gas tank.
- Do not try to fix the problem yourself.
- If odor continues or you have a fire you can not extinguish, call your fire department. Do not call near the LP gas tank because your telephone is a form of electrical device and could create a spark resulting in fire and/or explosion.

NOTE: The normal flow of gas through the regulator and hose assembly can create a humming noise. A low volume of noise is perfectly normal and will not interfere with operation of the grill. If humming noise is loud and excessive you may need to purge air from the gas line or reset the regulator excess gas flow device. This purging procedure should be done every time a new LP gas tank is connected to your grill. For help with this procedure refer to page 14, Item 4 of "If Grill Still Fails To Light", or call the Grill Information Center at 1-800-913-8999.

CAUTION: Beware of Flash-Back

CAUTION: Spiders and small insects occasionally spin webs or make nests in the grill burner tubes during transit and warehousing. These webs can lead to gas flow obstruction which could result in a fire in and around burner tubes. This type of fire is known as "FLASH-BACK" and can cause serious damage to your grill and create an unsafe operating condition for the user.

Although an obstructed burner tube is not the only cause of "FLASH-BACK", it is the most common cause.

To reduce the chance of "FLASH-BACK", you must clean the burner tubes before assembling your grill, and at least once a month in late summer or early fall when spiders are most active. Also perform this burner tube cleaning procedure if your grill has not been used for an extended period of time.

See Cleaning Burner Tubes and Ports on page # 18.

Burner Flame Check

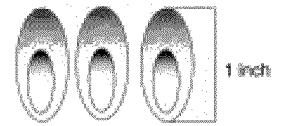
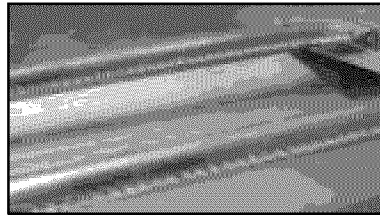

Visually check the burner flames prior to each use. The flames should look like picture, if they do not, refer to the cleaning burner tubes and ports, see page 15 of this manual.

Repair Protection Agreements

Congratulations on making a smart purchase. Your new Kenmore product is designed and manufactured for years of dependable operation. But like all products, it may require repair from time to time. That's when having a Repair Protection Agreement can save you money and aggravation.

Here's what the Repair Protection Agreement * includes:

- ✓ **Expert service** by our 10,000 professional repair specialists
- ✓ **Unlimited service and no charge** for parts and labor on all covered repairs
- ✓ **Product replacement** up to \$1500 if your covered product can't be fixed
- ✓ **Fast help by phone** - we call it Rapid Resolution - phone support from a Sears representative. Think of us as a "talking owner's manual"

Once you purchase the Repair Protection Agreement, a simple phone call is all that it takes for you to schedule service. You can call anytime day or night, or schedule a service appointment online.

The Repair Protection Agreement is a risk-free purchase. If you cancel for any reason during the product warranty period, we will provide a full refund. Or, a prorated refund anytime after the product warranty period expires.

Purchase your Repair Protection Agreement today!









Some limitations and exclusions apply. For prices and additional information in the U.S.A. call 1-800-827-6655.

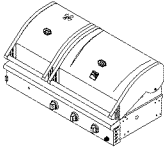





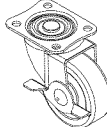
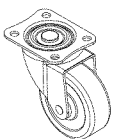
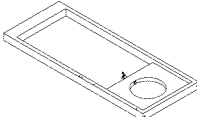
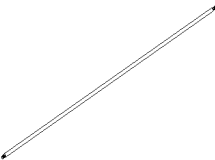
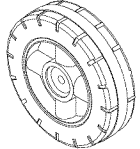
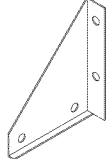
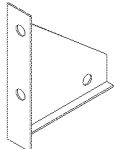
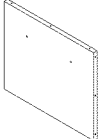

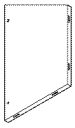
***Coverage in Canada varies on some items. For Full details call Sears Canada at 1-800-361-6665**

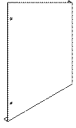
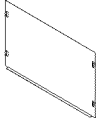
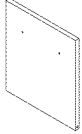
Sears Installation Service

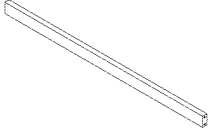
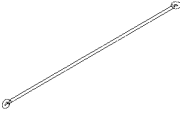
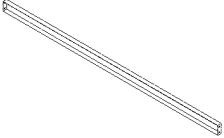
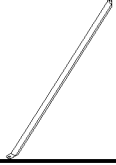
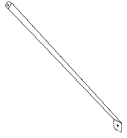
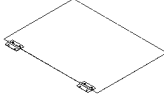
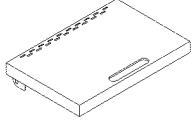
For Sears professional installation of home appliances, garage door openers, water heaters, and other major home items, in the U.S.A. or Canada call **1-800-4-MY-HOME.**

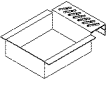
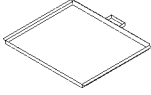
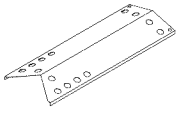
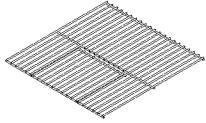
PACKAGE CONTENTS LIST

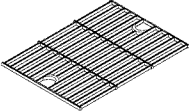
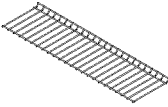
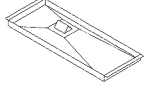
<p>A. Firebox -----1pc.</p> 	<p>B. Cart Leg, Front Left-----1pc.</p> 	<p>C. Cart Leg, Back Left----1pc.</p> 
<p>D. Cart Brace, Left-----1pc.</p> 	<p>E. Cart Leg, Front Right-----1pc.</p> 	<p>F. Cart Leg, Back Right----1pc.</p> 
<p>G. Cart Brace, Right -----1pc.</p> 	<p>H. Swivel Caster with Brake</p> 	<p>I. Swivel Caster-----1pc.</p> 
<p>J. Bottom Panel -----1pc.</p> 	<p>K. Wheel Axle-----1pc.</p> 	<p>L. Wheel-----2pcs.</p> 
<p>M. Triangle Bracket-----2pcs</p> 	<p>N. Triangle Bracket -----2pcs.</p> 	<p>O. Front Panel-----1pc.</p> 
<p>P. Towel Rack-----1pc.</p> 	<p>Q. Charcoal Bin bottom panel--1pc.</p> 	<p>R. Charcoal Bin Left side panel--1pc.</p> 

<p>S. Charcoal Bin Right Side Panel--1pc</p> 	<p>T. Charcoal Bin back panel--1pc.</p> 	<p>U. Charcoal Bin Front panel-1pc.</p> 
<p>V. Charcoal Bin Handle---1pc.</p> 	<p>W. Front Trim Panel-----1pc.</p> 	<p>X. Cart Beam, Front-----1pc.</p> 
<p>Y. Charcoal Bin Slide---2pcs.</p> 	<p>Z. Cart Beam, Back-----1pc.</p> 	<p>ZA. Gas Tank Barrier Bar --1pc.</p> 
<p>ZB. Gas Tank Barrier Bar --1pc.</p> 	<p>ZC. Charcoal Bin Cover---1pc.</p> 	<p>ZD. Side Shelf -----2pcs.</p> 
<p>ZE. 1.5 Volt "AA" Size Alkaline Battery-----1pc.</p> 	<p>ZF. Grease Cup-----1pc.</p> 	<p>ZG. Ash Tray-----1pc.</p> 
<p>ZH. Heat Diffuser-----3pcs.</p> 	<p>ZI. Charcoal Cooking Grid----1pc.</p> 	<p>ZJ. Charcoal Warming Rack---1pc</p> 
<p>ZK. Gas grill Cooking Grid--2pcs</p> 	<p>ZL. Gas Grill Warming Rack----1pc.</p> 	<p>ZM. Grease Tray---1pc.</p> 
<p>ZN. Crank Handle---1pc</p> 	<p>ZO. Manual Lighting Stick.-----1pc.</p> 	

Hardware Pack Contents

Pack	Description	Required for assembly(pcs)	Extra hardware (pcs)	Total (pcs)
AA	5/32-in. x 10-mm Round Head Screw	54	2	56
BB	5/32-in. Lock Washer	54	2	56
CC	1/4-in. x 15-mm Round Head Screw	20	2	22
DD	1/4-in. Lock Washer	28	2	30
EE	Allen Key	1	--	1
FF	1/4-in. Nut	2	1	3
GG	1/4-in. Flat Washer	2	1	3
HH	1/4-in. x 61-mm Round Head Screw	8	1	9
II	1/4-in. Flat Washer	8	1	9
JJ	5/32x6mm Flat head screw	4	1	5
KK	5/32-in.x 8-mm Stage Screw	2	1	3
LL	1/4-in. x 18-mm Stage Screw	8	1	9

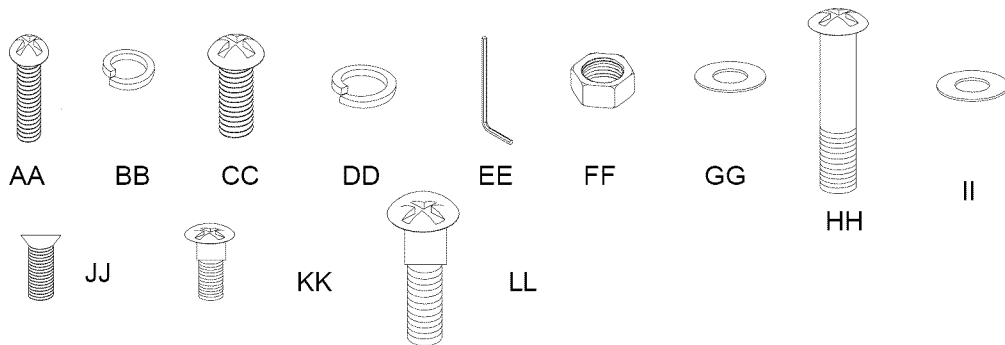

Preparation

Before beginning assembly, make sure all parts are present. Compare parts with package contents list and diagram above. If any part is missing or damaged, do not attempt to assemble the product. Contact customer service for replacement parts.

•Tools required for Assembly.

Phillips Screwdriver (not included) and Wrench (not included).



Phillips Screwdriver

Wrench

• Note: The grill right and left sides are on your right and left as you face the front of the grill.

Assembly Instructions

UNPACKING

CAUTION: Obtain the aid of an assistant when handling large or heavy grill components.

1. Once the top of shipping box is open, obtain the aid of an assistant and lift the cardboard sleeve up over Firebox and components.

2. Use sleeve as a work surface to protect floor and grill parts from scratches.
3. Remove all packing materials from around grill exterior.
4. Open both Firebox lids and remove packing materials and components inside each Firebox chamber. (See Next page)

Assembly Instructions

UNPACKING

5. With the aid of an assistant, lift the Firebox from the bottom of the shipping box and place on protected flat surface. Be careful not to damage hose and regulator.
6. Remove grill bottom panel from bottom of shipping box.
7. Refer to the Parts Lists to check that all parts are present.
8. Inspect the grill for damage as you assemble it. Do not assemble or operate grill if it appears damaged. If there are damaged or missing parts, call the Grill Information Center at 1-800-913-8999.

1. Grill Cart Assembly .

IMPORTANT: As an aid to assembly, see the Package Contents List and Hardware Pack Contents on pages 5, 6, and 7 for pictures and sizes of grill components and fasteners referenced by key letters in these instructions.

- a). Use 4 CC Round Head Screws and 4 DD Lock Washers to attach Cart Brace, Left (D) to Cart Leg, Front Left (B) and Cart Leg, Back Left (C). Attach Cart Brace, Left (D) so that flat side will face cart interior and wide lip faces down. See Fig. 1.

NOTE: Use Tab on Cart Leg, Front Left as indicator of Front Side of Grill during assembly.

- b). Use 4 CC Round Head Screws and 4 DD Lock Washers to attach Cart Brace, Right (G) to Cart Leg, Front Right (E) and Cart Leg, Back Right (F). Attach Cart Brace, Right (G) so that flat side will face cart interior and wide lip faces down. See Fig. 2.

2. Wheel Assembly

- a). Attach one Swivel Caster with Brake (H) and one Swivel Caster (I) to Bottom Panel (J) using 8 CC Round Head Screws and 8 DD Lock Washers. See Fig. 3.

- b). Insert Wheel Axle (K) through Cart Leg, Front Right (E) and Cart Leg, Back Right (F). Place Wheel (L), cone side facing Leg, on each end of Axle. Secure Wheel to Axle with 1 FF Nut and 1 GG Flat Washer.

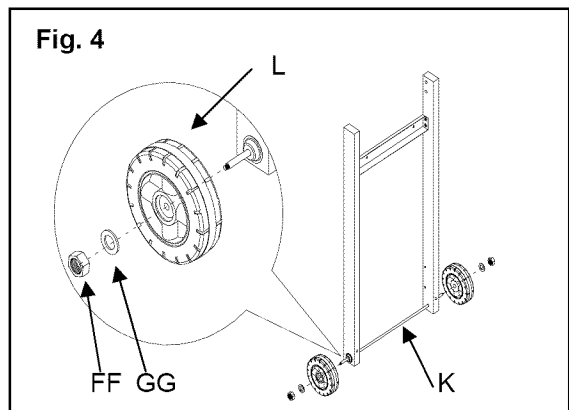
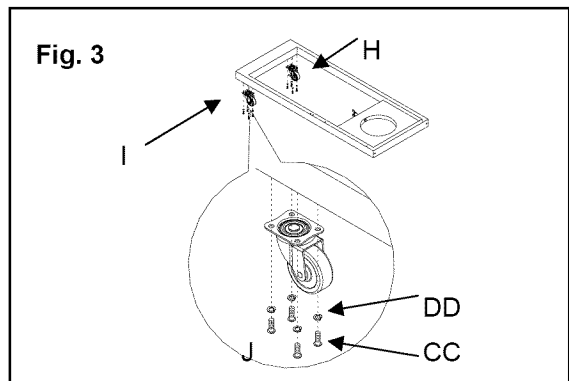
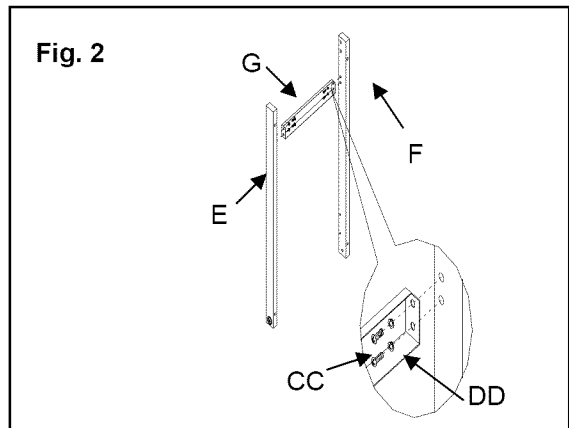
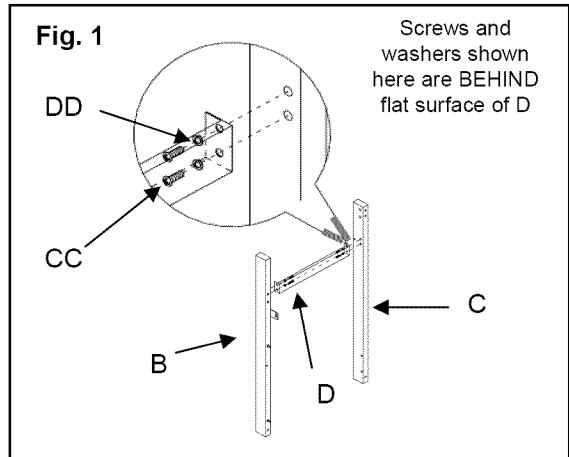

3. Bottom Panel Assembly

a) Use 4 HH Round Head Screws, 4 DD Lock Washers and 4 GG Flat Washers to attach and securely tighten Bottom Panel (J) to Left Cart Legs (E & F). See Fig. 5.

b) Repeat step 3a to attach and securely tighten Bottom Panel (J) to Right Cart Legs (B & C).

Note: Use Tank Hole on bottom panel as indicator of Right Side of Grill during assembly.

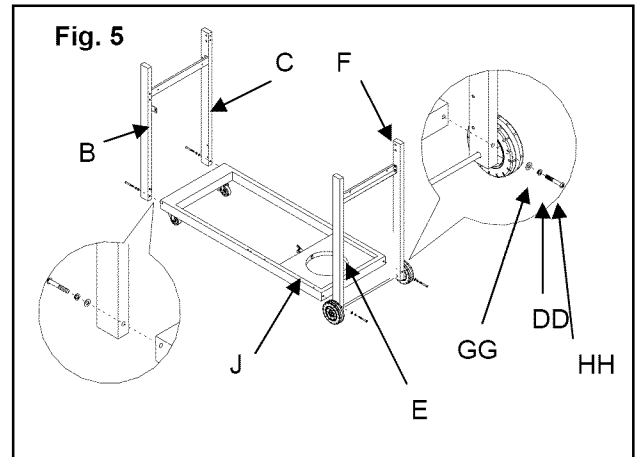

4. Triangle Bracket Assembly

a). Use 4 AA Round Head Screws and 4 BB Lock Washers to connect one Triangle Bracket (M) to Cart Leg, Back Right (E) and Bottom Panel (J). Use same hardware quantities to connect one Triangle Bracket (N) to Cart Leg, Front Right and Bottom Panel (J). See Fig. 6.

b) Repeat step 4a to attach Triangle Bracket M to Left Side Front Leg and Bottom Panel, and to attach Triangle Bracket N to Left Side Back Leg and Bottom Panel. See Fig. 6.

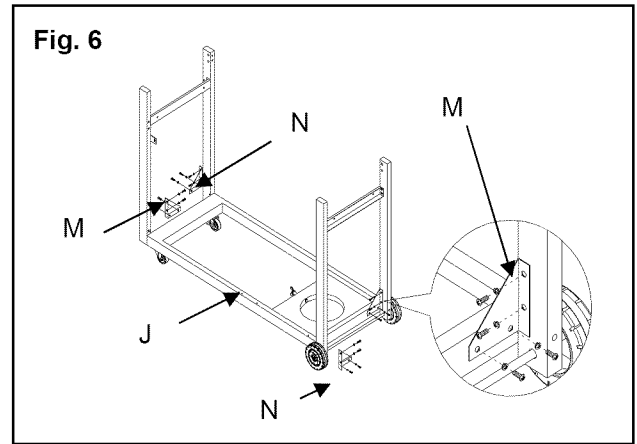

5. Front Panel Assembly

a). Use 3 AA Round Head Screws and 3 BB Lock Washers to connect front Panel (O) to Bottom Panel (J). See Fig. 7. Note: Don't attach Front Panel to Front Right Cart Leg at this time.

b). Use 2 AA Round Head Screws and 2 BB Lock Washers to attach Towel Rack (P) to Front Panel (O). See Fig. 8.

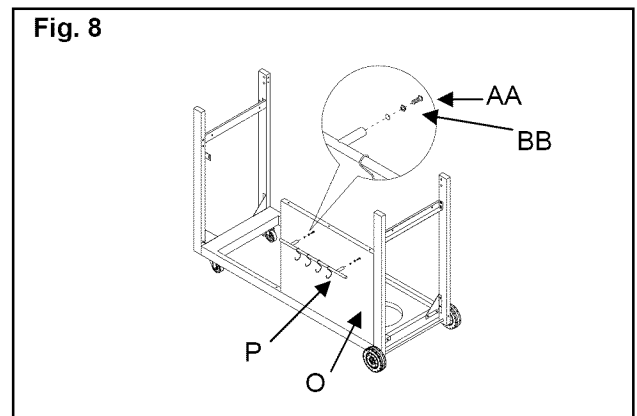
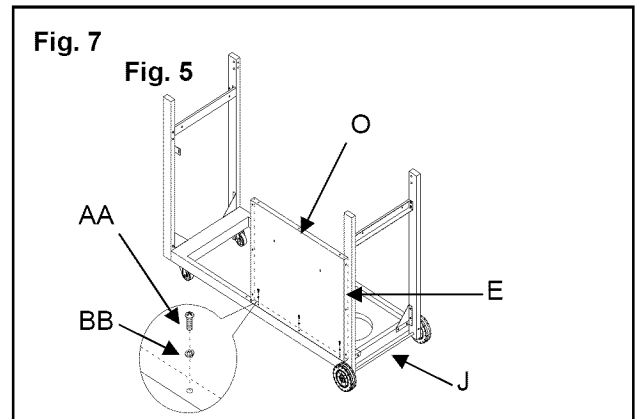

6. Charcoal Bin Assembly

a). Place Charcoal Bin Bottom Panel (Q) on a flat level surface. Connect Charcoal Bin Left (R) and Right (S) Side panels to Bottom Panel by securely hooking Bottom panel tabs into Side panel slots. See Fig. 9.

b). Securely hook Charcoal Bin Back Panel (T) tabs into Left and Right Side panel slots. See Fig. 10.

c). Use 6 AA Round Head Screws and 6 BB Lock Washers to connect Charcoal Bin Front Panel (U) to Side Panels and Bottom Panel. See Fig. 11. Note: Connection tabs go on the outside of Side and Bottom panels.

d) Use 2 AA Round Head Screws and 2 BB Lock Washers to attach Charcoal Bin Handle (V) to Charcoal Bin Front Panel (U). See Fig. 12.

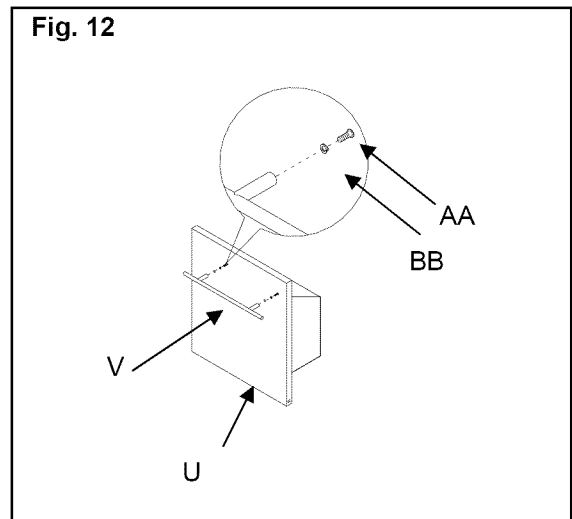
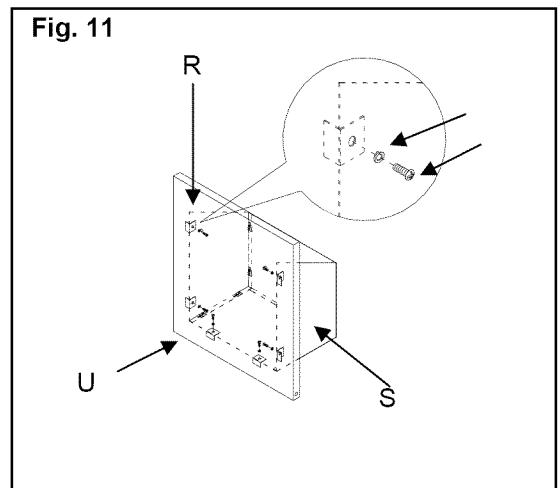
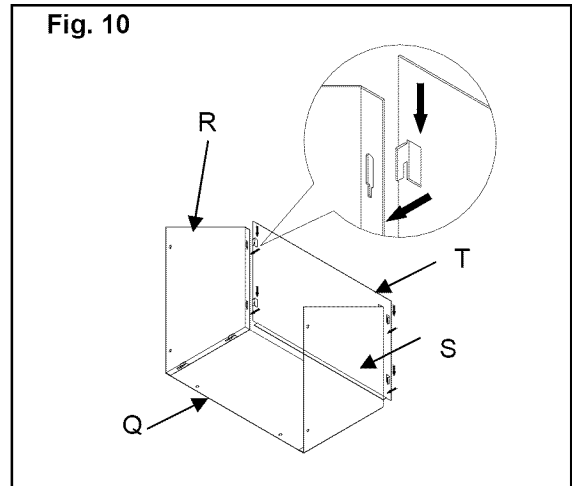
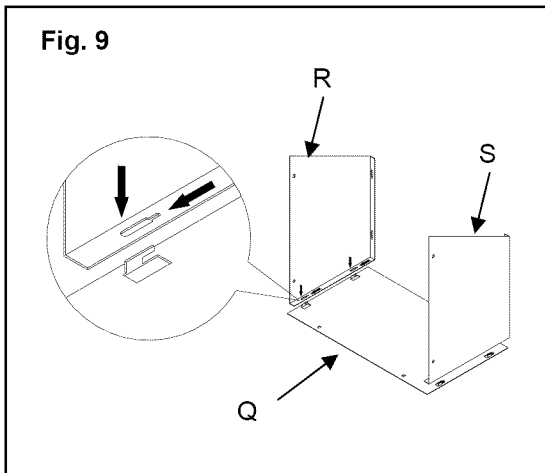

7. Front Trim Panel Assembly

a). Place Front Trim Panel (W) against right side of Charcoal Bin Front Panel. Fit Trim Panel hinge pin into hole onto bottom of Bin Front Panel. Tab at top of Trim Panel goes against back surface of Bin Front Panel. Holding Trim Panel and Bin Front Panel together, slide hole on bottom left side of Bin Front Panel onto hinge pin of Left Front Cart Leg. Align two holes on bottom right of Bin Front Panel with holes on Cart Bottom Panel (J). Secure Bin Front Panel to Bottom Panel with 2 AA Round Head Screws and 2 BB Lock Washers. See Fig. 13.

b). Attach Front Trim Panel (W) to Front Panel (O) with 3 AA Round Head Screws and 3 BB Lock Washers. Attach Front Panel.

c) Attach Front Panel (O) to Right Front Cart Leg (E) with 3 AA Round Head Screws and 3 BB Lock Washers. See Fig. 13.

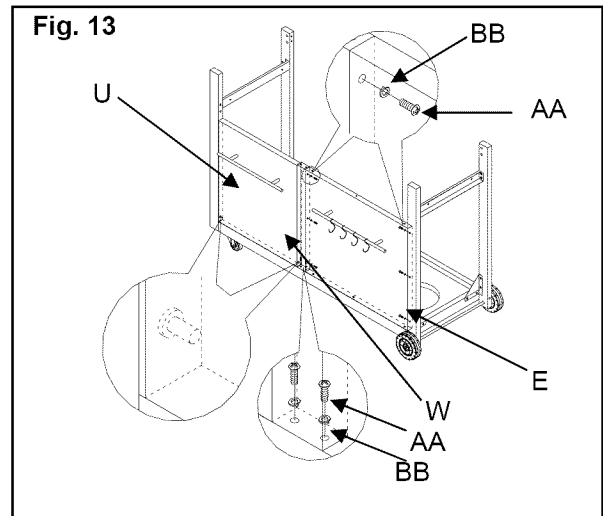

8. Cart Beam, Front Assembly

a). Use 4 AA Round Head Screws and 4 BB Lock Washers to connect Cart Beam, Front (X) to Cart Leg, Front Left (B) and Cart Leg, Front Right (E). See Fig. 14.

b). Use 5 AA Round Head Screws and 5 BB Lock Washers to connect Cart Beam, Front (X) bottom surface to Front Panel (O) and Front Trim Panel (W). See Fig. 14.

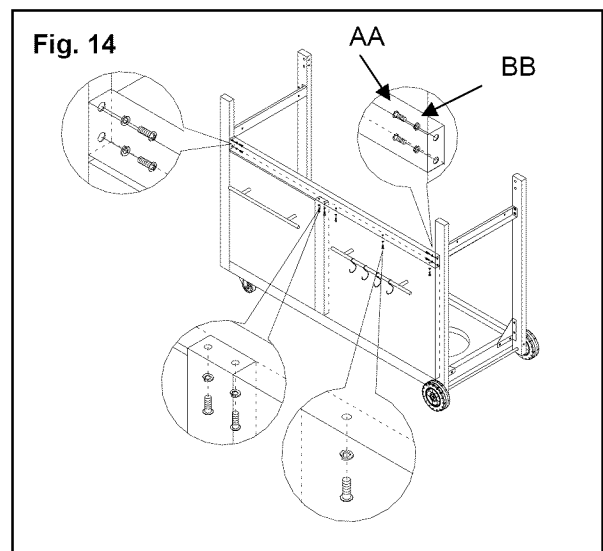

Note: Attach Cart Beam, Front so that flat side faces to cart exterior.

9. Charcoal Bin Slide Assembly

a). Pull and hold Charcoal Bin Front Panel forward, and insert the two Charcoal Bin Slides (Y) through the holes in the Front Trim Panel (W) and Left Front Cart Leg (B). See Fig. 15.

b). Use 2 KK Stage Screws to connect the loop hole ends of the Slides to the Charcoal Bin Front Panel. See Fig. 15.

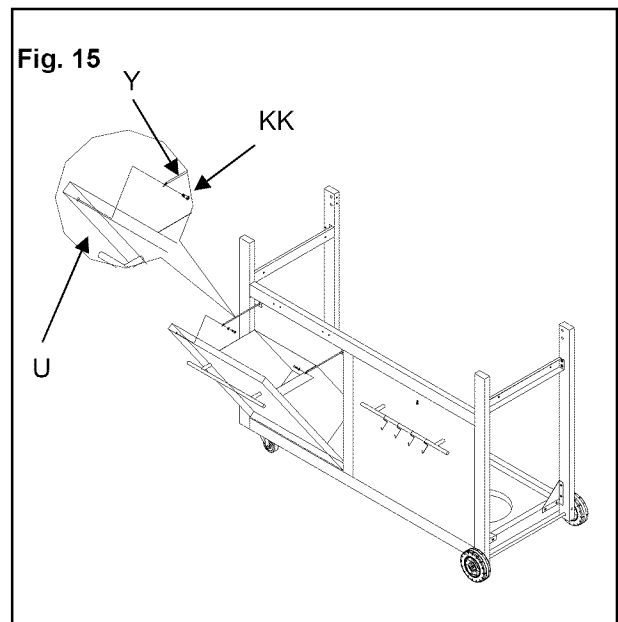

10. Cart Beam, Back Assembly

Use 4 AA Round Head Screws and 4 BB Lock Washers to attach Cart Beam, Back (Z) to Left Back Cart Leg (C) and Right Back Cart Leg (F). See Fig. 16.

NOTE: Flat side of Cart Beam, Back (Z) must face cart exterior.

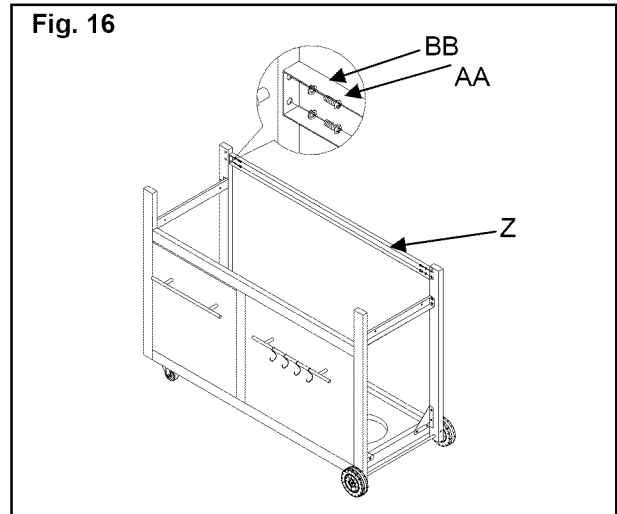

11. Gas Tank Barrier Bar Assembly

a). Use 2 AA Round Head Screws and 2 BB Lock Washers to secure Gas Tank Barrier Bar (ZA) to Front Trim Panel (W) and to Bottom Panel (J). See Fig. 17.

b). Use 2 AA Round Head Screws and 2 BB Lock Washers to secure Gas Tank Barrier Bar (ZB) to Bottom Panel (J) and then to Gas Tank Barrier Bar (ZA). See Fig. 18.

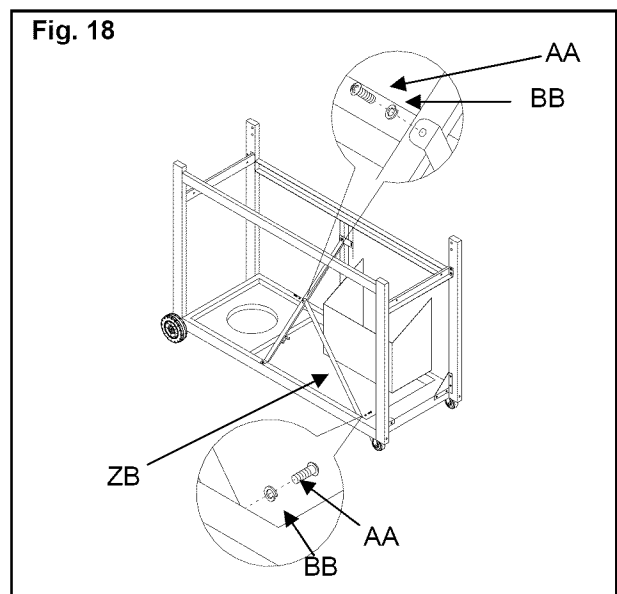
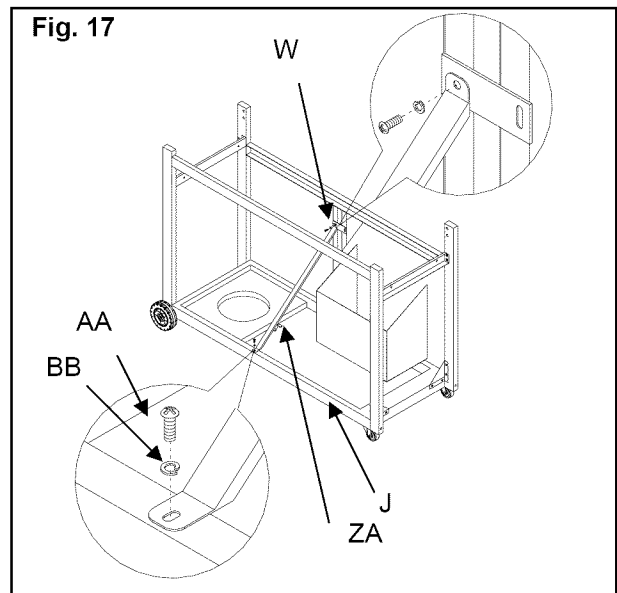

12. Charcoal Bin Cover Assembly

Use 4 JJ Flat Head Screws to connect hinges of Charcoal Bin Cover (ZC) to Cart Beam, Front (X). See Fig. 19.

13. Firebox Assembly

NOTE: Obtain the aid of an assistant to lift the Firebox. Be sure that the hose and regulator hang inside the cart when placing Firebox.

- With the aid of an assistant, raise the Firebox (A) and carefully place it onto the grill cart. See Fig. 20.
- Use 4 CC Round Head Screws and 4 DD Lock Washers to securely attach Firebox to Cart Frame, Left (D) and Cart Frame, Right (G). See Fig. 21.
- Insert Crank Handle (ZN) through hole in Firebox control panel and screw it into threaded socket for raising Charcoal Tray.

14. Side Shelves Assembly

Use 4 LL Stage Screws to attach one Fold-Down Side Shelf (ZD) to Back Right Cart Leg (F) and Front Right Cart Leg (E). See Fig. 22.

Repeat above procedure to attach other Fold-Down Side Shelf (ZD) to Front Left Cart Leg (B) and Back Left Cart Leg (C).

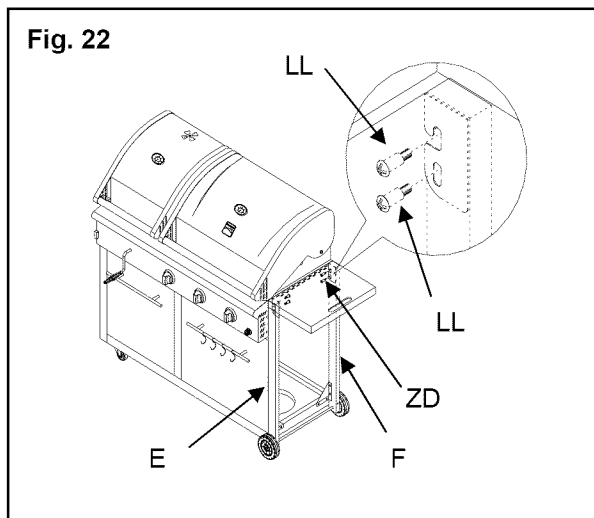
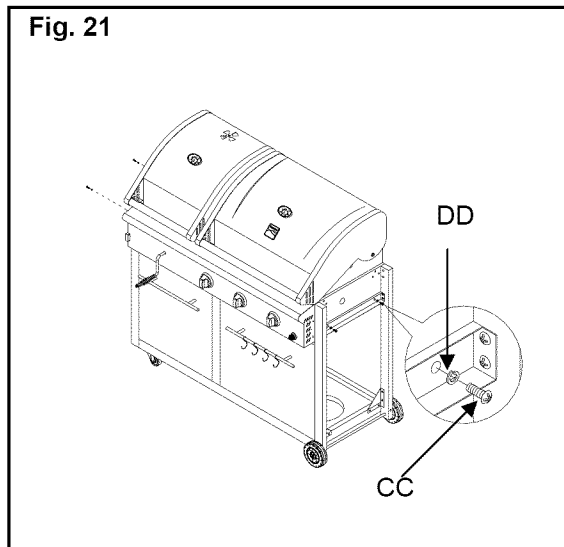
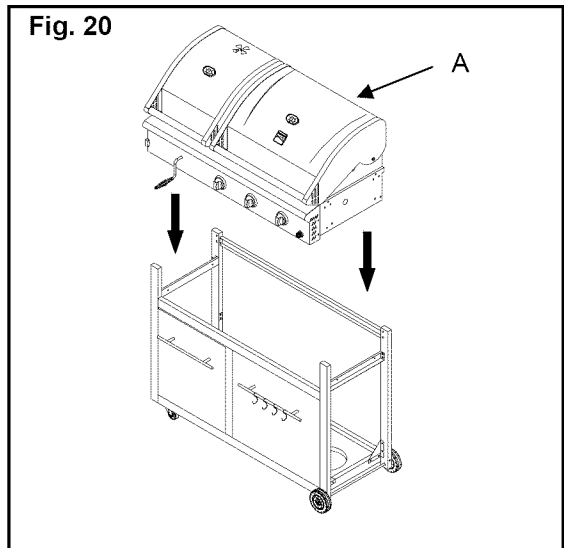
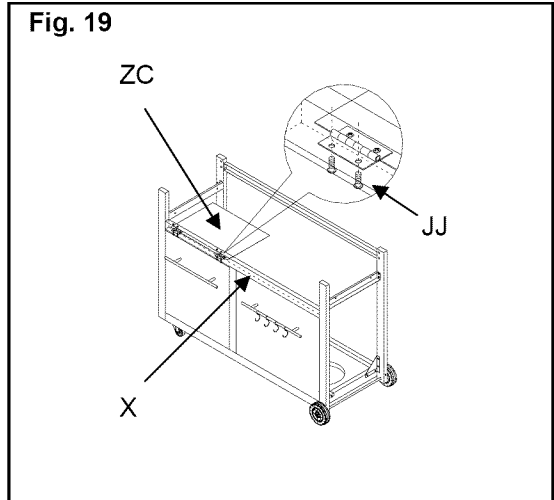

15. Electronic Ignition Battery Installation

Unscrew the electronic ignition button and place the Battery (ZE) into the housing with the positive terminal (+) facing outward. Replace the ignition button after the battery has been installed as shown in Fig. 23.

16. Install the Grease Tray & Charcoal Ash Tray

Install the Grease Tray (ZF) from the rear of the grill by sliding it all the way onto the glides underneath Gas firebox. Insert Grease Cup (ZF) into Grease Tray. See Fig. 24.

Note: Grease Tray Funnel must be toward the center of the grill.

Install the Ash Tray (ZG) by sliding it all the way onto the glides underneath the Charcoal firebox. See Fig. 24.

17. Installing Cooking Components

IMPORTANT: Before cooking on your grill the first time, wash cooking grids and cooking rack with warm, soapy water. Rinse and dry thoroughly. Season with cooking oil regularly. After cooking is completed, turn grill to HIGH setting for 3 to 5 minutes to burn off excess grease or food residue.

a). Install Heat Diffusers (ZH) above burners so that holes in diffuser corners attach securely onto pegs in the back ledge of firebox. See Fig. 25.

b). Evenly space Cooking Grids (ZK) over Diffusers on gas side of Grill. Insert Charcoal Cooking grid (ZI) above charcoal tray on Charcoal side of Grill. See Fig. 25.

c). Insert Charcoal Warming Rack (ZJ) and Gas Grill Warming Rack (ZL) into rack glides on top of side panels of each firebox. See Fig. 25.

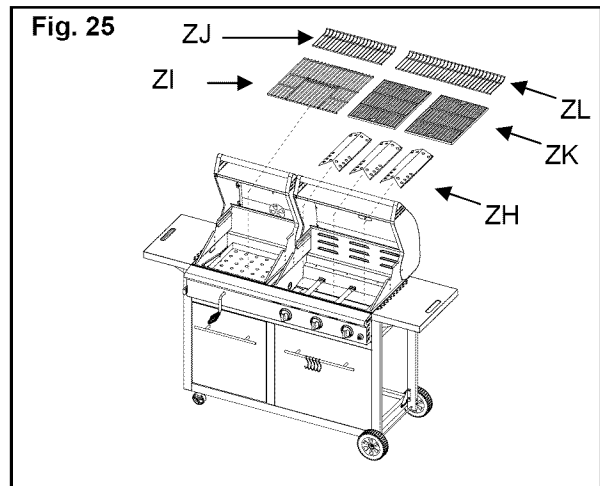
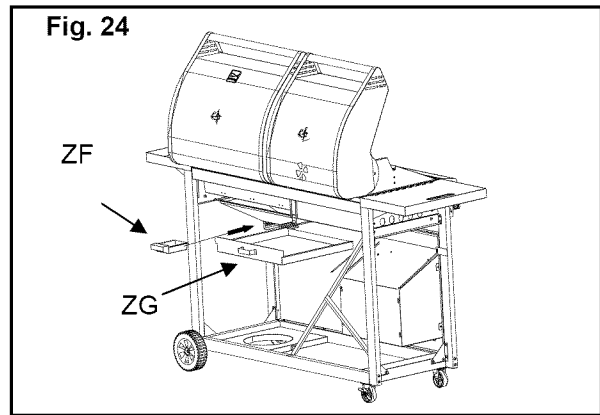
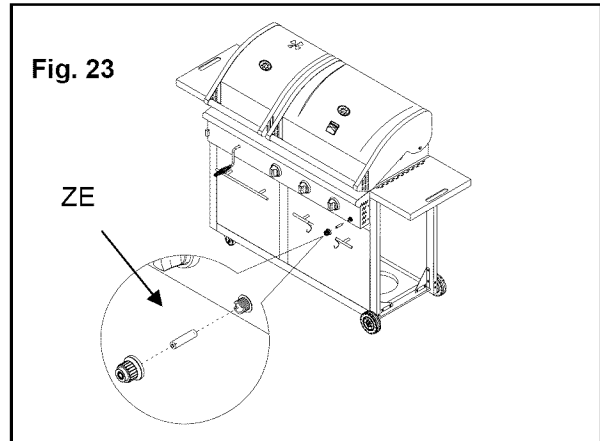

18. Connecting LP Gas Tank to LP Grill

1. From rear of the Cart, place the foot ring of 20-lb tank into the hole of the Bottom Panel (J). Make sure the tank valve is in OFF position. Use the tank bolt to secure the tank in a fixed position with tank valve facing out to side of Cart.
2. Check the tank valve to ensure it has proper external mating threads to fit the hose and regulator assembly provided.
3. Make sure all grill burner valves are in OFF position with Grill.
4. Inspect the tank valve connection port and grill regulator assembly. Look for damage or debris. Remove any debris. Inspect hose for damage. Never use damaged or plugged equipment.
5. When connecting regulator and hose assembly to tank valve hand tighten quick coupling nut clockwise to a full stop (Fig.27) Do not use a wrench to tighten because it could damage the quick coupling nut and result in a hazardous condition.
6. Open tank valve fully (counterclockwise) once tank and regulator are securely connected. Use a soapy water solution to check all connections for leaks before attempting to light your grill once tank and regulator are securely connected. If a leak is found, turn tank valve off and do not use your grill until the leak is repaired.

CAUTION: When the appliance is not in use, gas must be turned off at the supply tank.

Fig. 26

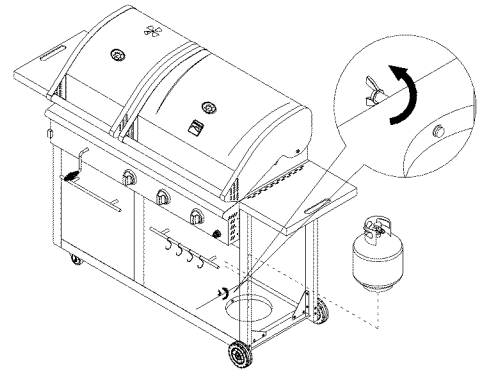
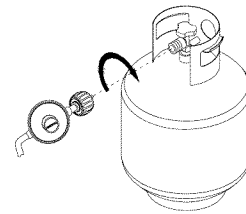

Fig. 27

Regulator Connection



Congratulations

Your Kenmore gas grill is now ready for use. Before the first use and at the beginning of each season (and whenever the LP gas tank has been changed):

1. Read all safety, lighting and operating instructions.
2. Check gas valve orifices, burner tubes and burner ports for any obstructions.
3. Perform gas leak check according to instructions found on next page of the manual.

Checking for LP gas leaks

Never test for leaks with a flame. Prior to first use, at the beginning of each season, or every time your LP gas tank is changed, you must check for gas leaks.

1. Make a 50/50 (soap/water) mild soap solution.
2. Turn the control knobs to full OFF position; then turn gas ON at supply tank.
3. Apply the soap solution with a clean brush to all gas connections. See below. If growing bubbles appear in the solution the connections are not properly sealed. Check each fitting and tighten or repair as necessary.

Gas Connection Leak Check

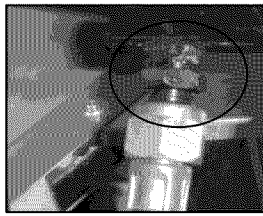
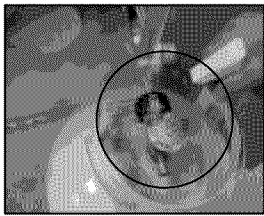

4. If you have a gas connection leak you cannot repair, turn gas OFF at supply tank, disconnect fuel line from your grill and call 1-800-913-8999 or your gas supplier for repair assistance.
5. Also apply soapy solution to the tank seams. See below. If growing bubbles appear, shut tank OFF and do not use or move it! Contact an LP gas supplier or your fire department for assistance.

Gas Tank Leak Check

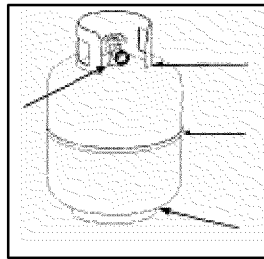

Grill Lighting Instruction

Grill Lighting Instructions for Main Burners

1. Do not smoke while lighting grill or checking gas supply connections.
2. Be sure that LP gas tank is sufficiently full.



WARNING

Failure to open grill lid during the lighting procedure could result in a fire or explosion that could cause serious bodily injury, death, or property damage.

3. Be sure all gas connections are securely tightened.
4. Open the Gas Grill Lid.
5. Push and turn any main burner knob to  HI position. Push Electronic ignition button for 3 to 5 seconds to light burner. Adjust knob to desired setting.

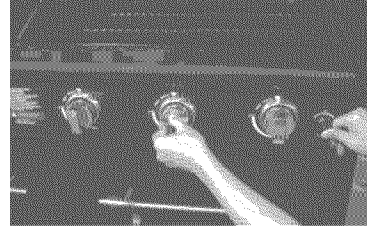

6. If the burner does not light after 5 seconds, turn knob to OFF. Turn gas OFF at LP tank and wait 5 minutes for gas to clear. Then turn gas ON at tank and repeat step 5
7. If burner still does not light, see Match Lighting section and If Grill Still Fails to Light section on following page.
8. To light additional burners, turn burner knob(s) to  HI. Push electronic ignition button for 3 to 5 seconds to light burner. Adjust knob(s) to desired setting.



WARNING

Never lean over the grill cooking area while lighting your gas grill. Keep your face and body a safe distance (at least 18 inches) from the cooking grid surface when lighting your grill by match.

Manually Lighting Your Grill by Match

1. Insert a match into the lighting stick.
2. Follow steps 1 through 5 of the Basic Lighting Procedure.
3. Light the match and extend the lighting stick to cooking grid surface.
4. Turn the desired control knob to the HI  position setting to release gas. The burner light immediately.

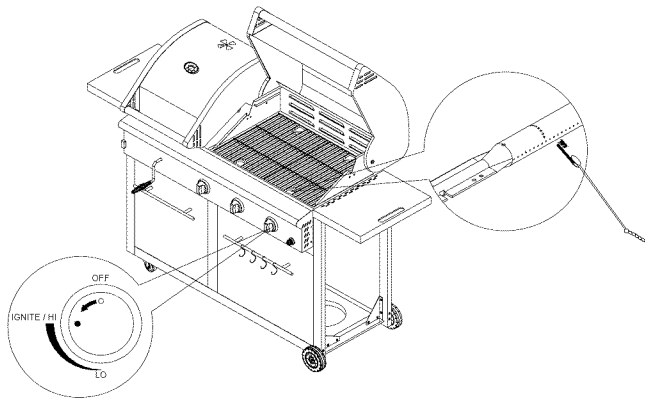

If Grill Still Fails To Light

1. Check gas supply and connections for leaks. Check that all wire connections are secure.

2. Repeat basic lighting procedure. If your grill still fails to operate, turn the gas off at source, turn the control knobs to OFF, then check the following:

- Misalignment of burner tubes over orifices

Correction: Reposition burner tubes over orifices.

- Plugged orifice

3. If an obstruction is suspected in grill burner gas valves, please call for repair service at 1-800-4-MY-HOME.

4. If the grill still does not light you may need to purge air from the gas line or reset the regulator excess gas flow device. **Note:** This procedure should be done every time a new LP gas tank is connected to your grill.

To purge air from your gas line and/or reset the regulator excess gas flow device:

- Turn the control knob to OFF position.
- Turn all burner control knobs to OFF position.
- Disconnect regulator from LP gas tank.
- Let unit stand for 5 minutes.
- Reconnect regulator to the LP gas tank.
- Turn the tank valve on slowly until $\frac{1}{4}$ to $\frac{1}{2}$ open.
- Open the grill lid.
- Push and turn any control knob to HIGH.
- Turn control knobs to HIGH until all the burners are lit
- You may start to use the grill

5. If all checks or corrections have been made and you still have questions about operating your gas grill, call the Grill Information Center at **1-800-913-8999**.



WARNING

Should a “FLASH-BACK” fire occur in/or around the burner tubes, follow the instructions below. Failure to comply with these instructions could result in a fire or explosion that could cause serious bodily injury, death, or property damage.

- Shut off gas supply to the gas grill.
- Turn the control knobs to OFF position.
- Put out any flame with a proper fire extinguisher.
- Open grill lid.
- Once the grill has cooled down, clean the burner tubes and burners according to the cleaning instructions found on page 15.

Cleaning and Maintenance for gas grill

To ensure a proper working unit the following proper care and maintenance is suggested.

Cleaning Cooking Grids

We suggest you wash your cooking grids in a mild soap and warm water solution. You can use a wash cloth or soft brush to clean your cooking grids.

Cleaning Heat Diffusers

Periodically you should wash the heat diffusers in a soap and warm water solution. Use a soft brush to remove stubborn burnt-on cooking residue. The heat diffusers should be dry before you reinstall them.

Cleaning Grease Tray

The grease tray should be emptied and wiped down periodically and washed in a mild detergent and warm water solution. A small amount of sand or cat litter may be placed in bottom of grease tray to absorb the grease. Check the grease tray frequently, don't allow excess grease to accumulate and overflow out of the grease tray.

Annual Cleaning of Grill Interior

Burning-off the grill after every use will keep it ready for your next use. However, once a year you should give the entire grill a thorough cleaning to keep it in top operating condition. Follow these steps.

1. Turn all burner valves to full OFF position.
2. Turn LP gas tank valve to full OFF position.
3. Detach LP gas hose and regulator assembly from your gas grill. Inspect for any damage and replace as necessary with manufacturer replacement part number found on parts list.
4. Remove and clean heat diffusers, cooking grids and grill burners.
5. Cover each gas valve orifice with aluminum foil.
6. Brush inside and bottom of grill with a nylon brush, and wash with a mild soap and warm water solution. Rinse thoroughly and let dry.
7. Remove the aluminum foil, then reinstall heat diffusers, and cooking grids.
8. Reconnect gas source and observe burner flame for correct operation.

Cleaning Exterior Surface

•We suggest you wash your grill using a mild soap and warm water solution. You can use a wash cloth or sponge for this process. Do not use abrasives or a brush that might remove finish during the cleaning process.

Cleaning Exterior Stainless Steel Surfaces

•Weathering and extreme heat can cause exterior stainless steel surfaces to turn tan in color. Machine oils used in manufacturing process of stainless steel can also cause this tanning color. Use a stainless steel cleaner to polish stainless steel surfaces of your grill. Never use abrasive cleaners or scrubbers because they will scratch and damage your grill.

Cleaning Burner Tubes and Burner Ports

To reduce the chance of "FLASH-BACK" the procedure below should be followed at least once a month in late summer or early fall when spiders are most active or when your grill has not been used for a period of time.

1. Turn all burner valves and gas tank valve to off position.
2. Detach the LP gas regulator assembly from your gas grill.
3. Remove cooking grids, heat diffusers, and grease tray from the grill.
4. Remove the screws from the underside of each burner and lift the burners up and away from the gas valve orifice.
5. Using a bent stiff wire in the shape of a hook, air hose or a bottle brush, run it through the burner tube and inside several times to remove any debris.
6. Replace burners, see illustration below.

Step 1. Locate the burner onto the orifice.

Step 2. Secure the main burner on the back wall of fire box with 2 screws.

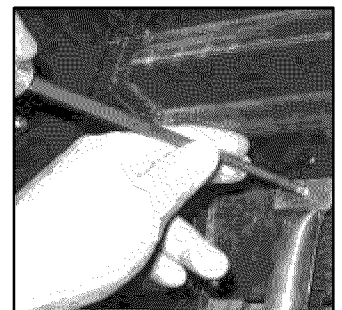
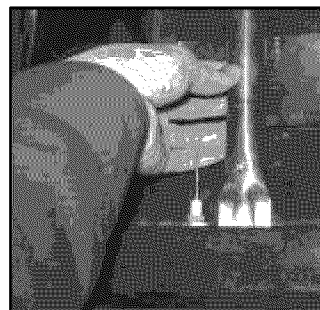

WARNING

The location of the burner tube with respect to the orifice is vital for safe operation. Check to ensure the orifice is inside the burner tube before using the gas grill. If the burner tube does not fit over the valve orifice, lighting the burner may cause explosion and/or fire.

Regardless of which burner cleaning procedure you use, we recommend you also complete the following steps to help prolong burner life.

1. Use a fiber pad or nylon brush to clean the entire outer surface of each burner until free of food residue and dirt.
2. Clean any clogged ports with a stiff wire, such as an open paper clip.

3. Inspect each burner for damage (cracks or holes) and if such damage is found, order and install a new burner. After installation check to ensure that gas valve orifices are correctly placed inside the ends of the burner tubes.

 **WARNING**
 Spiders and insects can nest inside the burners of the grill and disrupt gas flow. This very dangerous condition could cause a fire behind the valve panel, thereby damaging the grill and making it unsafe for operation. Inspect the grill at least twice a year.

Troubleshooting

BEFORE CALLING FOR SERVICE

If the grill does not function properly, use the following check list before calling for service.

You should inspect the burners at least once a year or immediately after any of the following conditions occur:

PROBLEMS	WHAT TO DO
Grill won't light when the control knob is rotated.	Check to see if LP tank is empty. Clean wires and/or electrode by rubbing with alcohol and clean swab. Wipe with dry cloth. Make sure the wire is connected to electrode assembly. Do other burners on the unit operate? Check to see if other burners operate. If so, check the gas orifice on the malfunctioning burner for an obstruction.
Burner flame is yellow or orange, in combination with the odor of gas.	Refer to Clean Burner Tubes and Burner Ports on page 18. If problem still exists, please call 1-800-913-8999.
Low heat with knob in "HI" position.	Is the fuel hose bent or kinked? Is the grill in a dusty area? Is there adequate gas supply available? If it is only one burner that appears low, does the orifice or burner need cleaning? Is the gas supply or gas pressure low?

Charcoal Grill Information

WARNING

- Keep a fire extinguisher nearby at all times.
- This grill is for outdoor use only, in well-ventilated areas.
- The use of alcohol, prescription or non-prescription drugs may impair the user's ability to properly assemble and safely operate this unit.
- Use caution when lifting and moving the unit to avoid back strain or back injury. Two people are recommended to lift or move the unit. Do not move the unit while it is in use.
- DO NOT operate the unit near or under flammable or combustible materials such as decks, porches or carports. A minimum clearance of 36 in. (92 cm) is recommended. DO NOT operate the unit under overhead construction.
- This product is not to be used as a heater.
- Operate the unit on a stable, level, non-flammable surface such as asphalt, concrete or solid ground. DO NOT operate the unit on flammable material such as carpet or a wood deck.
- Use caution when assembling and operating this unit to avoid cuts and scrapes from edges.
- DO NOT use this product in a manner other than its intended purpose. It is NOT intended for commercial use. It is not intended to be installed or used in or on a recreational vehicle and/or boats.
- DO NOT Store this unit near gasoline or other combustible liquids or where other combustible vapors may be present.
- DO NOT store or operate this product in an area accessible to children or pets. Store this unit in a dry, protected location.
- DO NOT leave the unit unattended while in use.
- DO NOT leave hot ashes unattended until the grill cools completely.
- DO NOT move the unit while in use or while ashes are still hot. Allow the unit to cool completely before moving or storing.
- NEVER use gasoline or other highly volatile fluids as a starter.
- Always wait for any charcoal flames to subside before placing food on cooking grid.

- Dispose of cold ashes by wrapping them in a heavy-duty aluminum foil and placing in a noncombustible container. Make sure that there are no other combustible materials in or near the container.
- If you must dispose of ashes in less time then it takes for the ashes to completely cool down, then remove the ashes from the unit, keeping them in the heavy-duty foil, and soak them down with water before disposing in a noncombustible container.
- Allow the unit to cool completely before conducting any routine cleaning or maintenance.

California Proposition 65 WARNING: Combustion (burning) of charcoal or charcoal-like briquettes, like other cooking methods, produces carbon monoxide and other substances known by the State of California to cause cancer, birth defects or reproduction harm.

Operating Tips

Charcoal Grid Hinge

When the grill is completely cooled, raise the hinged section of Charcoal Grid to add charcoal to the Charcoal Tray.

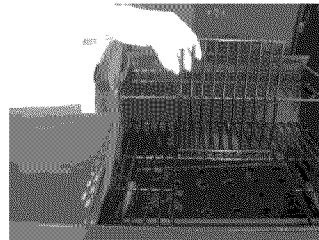

Crank Handle Operation

By turning the crank handle, the charcoal tray can be raised or lowered to adjust the cooking heat at any time while cooking. Raising tray increases the heat, and lowering tray reduces heat. Raise the tray after unit has cooled down completely to make it easier brush ashes into Ash Tray. Do not raise the tray higher than halfway when fully loaded with fresh charcoal.

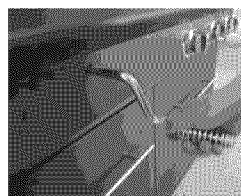

Charcoal Lighting Instructions

1. Open grill lid, as well as damper vents on side of grill.
2. Raise the hinged section of Charcoal Grid to add charcoal to the Charcoal Tray.
3. Turn crank to adjust charcoal tray to middle height position.
4. Pour 5 pounds of regular charcoal briquets into charcoal tray and arrange into a pile. Make sure charcoal does not go above the Charcoal Grid.
5. Light charcoal briquets.
6. Turn crank to lower charcoal tray to bottom position. Wait for charcoal flames to subside.
7. Once briquets are glowing, turn crank to adjust charcoal tray to desired cooking position.

ADJUSTING TEMPERATURE

For maximum heat, open the damper vents on the side of the firebox by pulling damper control out all the way. To reduce the heat, push in the damper control as desired.

NOTE: The temperature should not exceed 500° F, If temperature becomes too hot, reduce the quantity of briquets in the tray. The temperature can be checked using the temperature gauge on the grill lid.

Cooking Instructions For Gas Grill



WARNING

Do not leave the grill unattended.

Your grill will get very hot. Never lean over the cooking area while using your grill. Do not touch cooking surfaces, grill housing, Grill Lid or any other grill parts while the grill is in operation, or until the grill has cooled down after use. Failure to comply with these instructions may result in serious bodily injury.

Burn-off

Before cooking on your gas grill for the first time, you will want to “burn off” the grill to eliminate any odor or foreign matter. Just ignite the burners, lower the Lid, and operate grill on the HIGH setting for 3 to 5 minutes.

Cooking Temperatures

High setting: Only use this setting for fast warm-up, searing steaks or chops and for burning food residue off the grill after cooking is complete. **Never** use the HIGH setting for extended cooking.

Medium to Low Settings: Most recipes specify medium to low settings, including all smoking, rotisserie cooking and for cooking lean cuts such as fish.

NOTE: Temperature settings will vary with the temperature and the amount of wind outside your home.

Direct Cooking

The direct cooking method can be used with the supplied cooking grids and food placed directly over the lit grill Burners. The method is ideal for searing and whenever you want meat, poultry or fish to have an open-flame barbecued taste. Deep frying and smoking are also best cooked in this manner because they require direct heat.



WARNING

Do not line the bottom of the grill housing with aluminum foil, sand or any substance that will restrict the flow of grease into the grease tray. Failure to comply with these instructions could result in a fire or explosion which could cause serious bodily injury, death, or property damage.

Indirect Cooking

To cook **indirectly**, the food should be placed on the left or right side of your grill with the burner lit on the opposite side.

Flare-ups

The fats and juices dripping from grilled food can cause flare-ups. Since flare-ups impart a favorably distinctive taste and color to food cooked over an open flame, they should be accepted up to a point. Nevertheless, uncontrolled flaring can result in a ruined meal.

Cooking Chart

WARNING: To ensure that it is safe to eat, food must be cooked to the minimum internal temperatures listed in the table below.

USDA* Safe Minimum Internal Temperatures	
Fish	145° F
Pork	160° F
Egg Dishes	160° F
Steaks and Roasts of Beef, Veal or Lamb	145° F
Ground Beef, Veal or Lamb	160° F
Whole Poultry (Turkey, Chicken, Duck, etc.)	165° F
Ground or Pieces Poultry (Chicken Breast, etc.)	165° F

* United States Department of Agriculture

FOOD	Weight or thickness	Temperature	Time	Special instructions and tips
Vegetables	NA	Medium	8 to 20 minutes	Slice or chop vegetables and dot with butter or margarine. Wrap tightly in heavy duty foil. Grill turning occasionally.
Potatoes	Whole	Medium	40 to 60 minutes	Wrap individually in heavy duty foil. Cook rotating occasionally.
Meat/Steaks	1/2 to 3/4 inches	High-Medium	4 to 15 minutes	Pre heat grill for 15-20 minutes then sear steaks on each side for two minutes. Next grill 3 to 5 minutes on each side or until desired doneness.
Ground Meats	1/2 to 3/4 inches	Medium	8 to 15 minutes	Grill turning once when juices rise to the surface or until desired amount of doneness. Do not leave hamburgers unattended since a flare-up could occur quickly.
Ribs	1/2 or full rack	Medium	20 to 40 minutes	Grill turning occasionally. During last few minutes brush with barbecue sauce, turn several times.
Hot dogs	NA	Medium	5 to 10 minutes	Grill turning four times. 2-4 minutes on each of four sides.
Poultry-Cut	1/4 to 1/2 pounds	Low or Medium	20 to 40 minutes	Grill turning occasionally. During last few minutes brush with barbecue sauce if desired, turn several times.
Poultry Whole	2 to 3 pounds	Low or	1 to 1-1/2 hours	Use poultry stand and brush frequently as desired
		Medium	40 to 60 minutes	Use poultry stand and brush frequently as desired
Fish	3/4 to 1 inch	Medium	8 to 15 minutes	Grill turning once to desired doneness. Brush with melted butter, margarine or oil.

Model 122.16431010 Parts diagram

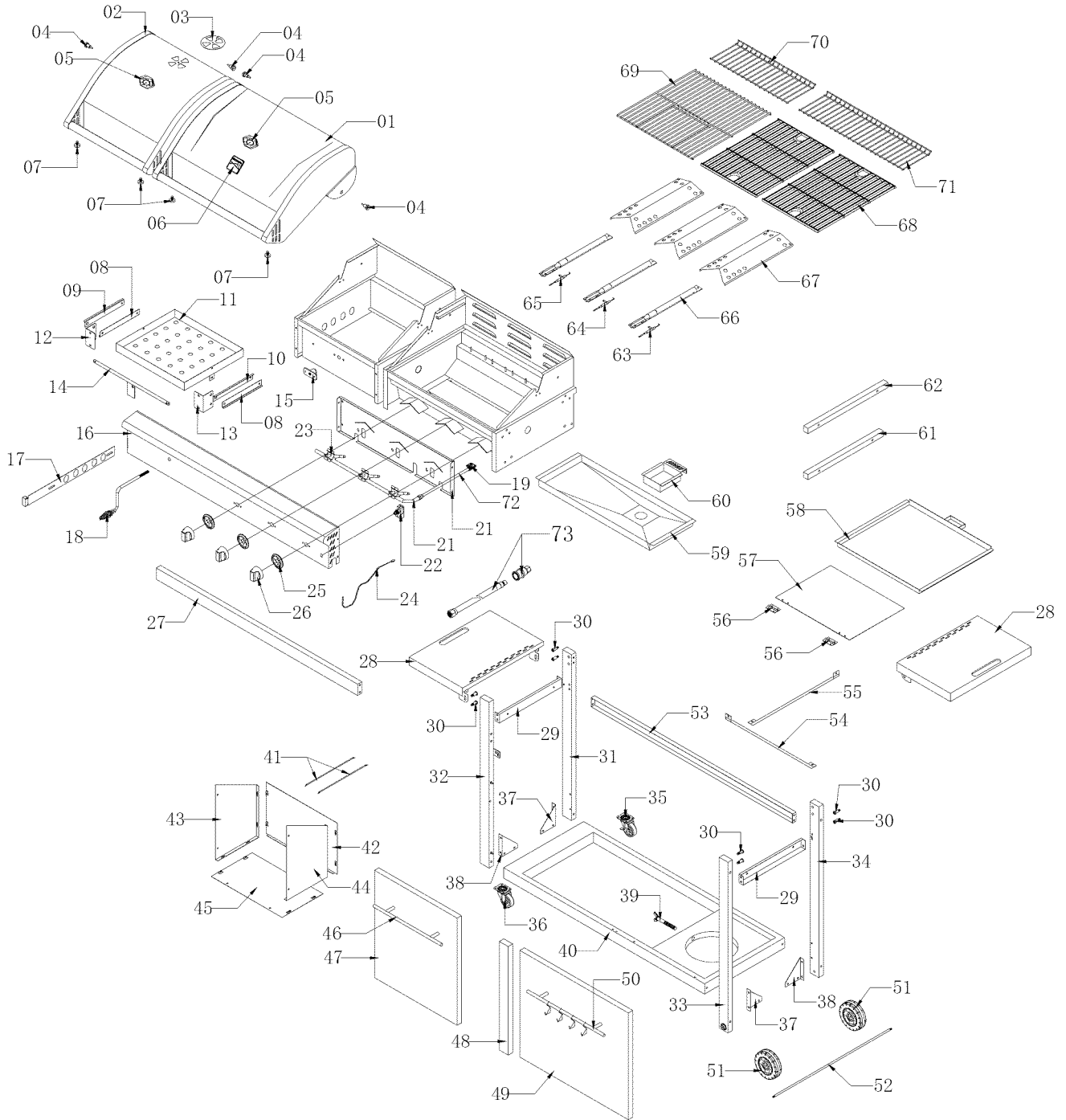

Model 122.16431010 Parts List

KEY#	PARTS	DESCRIPTION	QUANTITY	KEY#	PARTS	DESCRIPTION	QUANTITY
1	718-001	Main Lid, grill	1	37	718-037	Triangle Bracket A	2
2	718-002	Main Lid, Charcoal	1	38	718-038	Triangle Bracket B	2
3	718-003	Damper	1	39	718-039	Tank Bolt	1
4	718-004	Main Lid Screw	4	40	718-040	Bottom Panel, LP	1
5	718-005	Temperature Gauge	2	41	718-041	Charcoal Bin Slide	2
6	718-006	Logo	1	42	718-042	Charcoal Bin Back Panel	1
7	718-007	Hood Buffer	4	43	718-043	Charcoal Bin Side Panel, Left	1
8	718-008	Charcoal Tray Rasing Bracket A	2	44	718-044	Charcoal Bin Side Panel, Right	1
9	718-009	Charcoal Tray Rasing Bracket B	1	45	718-045	Charcoal Bin Bottom Panel	1
10	718-010	Charcoal Tray Rasing Bracket C	1	46	718-046	Charcoal Bin Handle	1
11	718-011	Charcoal Tray	1	47	718-047	Charcoal Bin Front Panel	1
12	718-012	Charcoal Tray L Shape Bracket A	1	48	718-048	Front Trim Panel	1
13	718-013	Charcoal Tray L Shape Bracket B	1	49	718-049	Front Panel	1
14	718-014	Charcoal Tray Crank	1	50	718-050	Towel Rack	1
15	718-015	Charcoal Tray Handle Bracket	1	51	718-051	Wheel	2
16	718-016	Main Control Panel	1	52	718-052	Wheel Axle	1
17	718-017	Pilot Box Cover	1	53	718-053	Cart Beam, Back	1
18	718-018	Crank Handle	1	54	718-054	Gas Tank Barrier Bar	1
19	718-019	Regulator, LP	1	55	718-055	Gas Tank Barrier Bar	1
20	718-020	Front Baffle	1	56	718-056	Hinge	2
21	718-021	Main Manifold	1	57	718-057	Charcoal Bin Cover	1
22	718-022	Pulse Igniter Module	1	58	718-058	Ash Tray	1
23	718-023	Main Gas Valve	1	59	718-059	Grease Tray	1
24	718-024	Manual Lighting Stick	1	60	718-060	Grease Cup	1
25	718-025	Bezel	3	61	718-061	Cart Beam top, Middle	1
26	718-026	Control Knob	3	62	718-062	Cart Frame top, Middle	1
27	718-027	Cart Beam, Front	1	63	718-063	Main Burner Igniter Wire A	1
28	718-028	Side Shelf	2	64	718-064	Main Burner Igniter Wire B	1
29	718-029	Cart Brace	2	65	718-065	Main Burner Igniter Wire C	1
30	718-030	Side Shelf Stage Screw	8	66	718-066	Main Burner	3
31	718-031	Cart Leg, Rear Left	1	67	718-067	Heat Diffuser	3
32	718-032	Cart Leg, Front, Left	1	68	718-068	Grill Cooking Grid w ith hole	2
33	718-033	Cart Leg Front Right	1	69	718-069	Charcoal Cooking Grid	1
34	718-034	Cart Leg, Rear Right	1	70	718-070	Charcoal Warming Rack,	1
35	718-035	swivel caster with brake	1	71	718-071	Grill Warming Rack,	1
36	718-036	Swivel Caster Triangle Bracket	1				

If you are missing hardware or have damaged parts after unpacking grill, call 1-800-913-8999 for replacements.

To order replacement parts after using grill, call:

1-800-4-MY-HOME[®]

To make sure you obtain the correct replacement parts for your Kenmore gas grill, please refer to the part numbers on this page.

Important: Keep this Use & Care Guide for convenient reference and for part replacement.

Important: Use only parts listed above. When ordering parts, providing the following information:

1. Model #
2. Serial # (found inside the front panel of your grill)
3. Part Number (see PART# in chart)
4. Part Description
5. Quantity of parts needed

Get it fixed, at your home or ours!

Your Home

For expert troubleshooting and home solutions advice:

manage my home

www.managemyhome.com

For repair – **in your home** – of **all** major brand appliances, lawn and garden equipment, or heating and cooling systems, **no matter who made it, no matter who sold it!**

For the replacement parts, accessories and owner's manuals that you need to do-it-yourself.

For Sears professional installation of home appliances and items like garage door openers and water heaters.

1-800-4-MY-HOME® (1-800-469-4663)

Call anytime, day or night (U.S.A. and Canada)

www.sears.com www.sears.ca

Our Home

For repair of carry-in items like vacuums, lawn equipment, and electronics, call anytime for the location of your nearest

Sears Parts & Repair Service Center

1-800-488-1222 (U.S.A.) **1-800-469-4663** (Canada)

www.sears.com www.sears.ca

To purchase a protection agreement on a product serviced by Sears:

1-800-827-6655 (U.S.A.) **1-800-361-6665** (Canada)

Para pedir servicio de reparación a domicilio, y para ordenar piezas:

1-888-SU-HOGAR®

(1-888-784-6427)

Au Canada pour service en français:

1-800-LE-FOYER^{MC}

(1-800-533-6937)

www.sears.ca

Sears